

INSTRUCTION MANUAL

Effective October 1, 2001: All Montague heavy duty ranges and broilers will be built with orifices and regulators set to operate on 6" W.C. manifold pressure.

You must specify the manifold pressure and gas type listed on the model identification plate to order replacement burner valves, orifices, or pressure regulators.

MONTAGUE LEGEND

Gas Fired Heavy Duty Convection Oven Ranges

**Models:
V136 Series**

**These instructions should be read thoroughly before attempting installation.
Set up and installation should be performed by qualified installation personnel.**

Keep area around appliances free and clear from combustibles.

**PLEASE RETAIN THIS MANUAL
FOR FUTURE REFERENCE.**



THE MONTAGUE COMPANY
1830 STEARMAN AVENUE, P.O. BOX 4954
HAYWARD, CA 94540-4954
TEL: 510/785-8822 FAX: 510/785-3342

CONTENTS

| | | | |
|-------------------------|----|-------------------------|----|
| INSTALLATION | 1 | MAINTENANCE | 14 |
| OPERATION | 8 | SERVICE | 17 |
| COOKING HINTS | 11 | RENEWAL PARTS | 29 |

IMPORTANT

WARNING:

Improper installation, adjustment, alteration, service or maintenance can cause property damage, injury or death. Read the operating and maintenance instructions thoroughly before installing or servicing this equipment.

FOR YOUR SAFETY:

Do not store or use gasoline or other flammable vapors and liquids in the vicinity of this or any other appliance.

INSTRUCTIONS TO BE FOLLOWED IN THE EVENT THE USER SMELLS GAS MUST BE POSTED IN A PROMINENT LOCATION. THIS INFORMATION MAY BE OBTAINED BY CONSULTING THE LOCAL GAS SUPPLIER.

SHIPPING DAMAGE CLAIM PROCEDURE:

For your protection, please note that equipment in this shipment was carefully inspected and packed by skilled personnel before leaving the factory. The transportation company assumed full responsibility for safe delivery upon acceptance of this shipment.

If shipment arrives damaged:

- 1. VISIBLE LOSS OR DAMAGE** — Be certain this is noted on freight bill or express receipt, and signed by person making delivery.
- 2. FILE CLAIM FOR DAMAGES IMMEDIATELY** — Regardless of the extent of damage.
- 3. CONCEALED LOSS OR DAMAGE** — If damage is unnoticed until merchandise is unpacked, notify transportation company or carrier immediately, and file "concealed damage" claim with them. This should be done within fifteen (15) days of date that delivery was made to you. Be sure to retain container for inspection.

We cannot assume responsibility for damage incurred in transit. We will, however, be glad to furnish you with necessary documents to support your claim.

INSTALLATION

The Montague gas ranges are manufactured for use with the type of gas indicated on the nameplate.

The Montague heavy duty gas convection oven type ranges are produced with the best possible material and workmanship. PROPER INSTALLATION IS ESSENTIAL FOR SAFE AND EFFICIENT TROUBLE-FREE OPERATION.

THE INSTALLATION INSTRUCTIONS CONTAINED HEREIN ARE FOR THE USE OF QUALIFIED INSTALLATION AND SERVICE PERSONNEL ONLY. INSTALLATION OR SERVICE BY OTHER THAN QUALIFIED PERSONNEL MAY RESULT IN DAMAGE TO THE RANGE AND/OR INJURY TO THE OPERATOR.

Qualified installation personnel are individuals, a firm, corporation or company which either in person or through a representative are engaged in, and are responsible for:

- A. The installation or replacement of gas piping or the connection, installation, repair or servicing of equipment, who is experienced in such work, familiar with all precautions required, and has complied with all requirements of state or local authorities having jurisdiction. Reference: National Fuel Gas Code Z223.1-1984, Section 1.4.
- B. The installation of electrical wiring from the electric meter, main control box or service outlet to the electric appliance. Qualified installation personnel must be experienced in such work, be familiar with all precautions required and have complied with all requirements of state or local authorities having jurisdiction. Reference: National Electrical Code, ANSI/NFPA No. 70-1984.

CAREFULLY READ AND FOLLOW THESE INSTRUCTIONS

THE RANGE(S) MUST BE INSTALLED IN ACCORDANCE WITH LOCAL CODES, OR IN THE ABSENCE OF LOCAL CODES, WITH THE NATIONAL FUEL GAS CODE, ANSI Z223.1-1984, INCLUDING:

1. The appliance and its individual shutoff valve must be disconnected from the gas supply piping system during any pressure testing of that system at test pressures in excess of 1/2 psig (3.45 kPa).
2. The appliance must be isolated from the gas supply piping system by closing its individual manual shutoff valve during any pressure testing of the gas supply piping system at test pressure equal to or less than 1/2 psig (3.45 kPa).

THE UNIT WHEN INSTALLED MUST BE ELECTRICALLY GROUNDED IN ACCORDANCE WITH LOCAL CODES, OR IN ABSENCE OF LOCAL CODES, WITH THE NATIONAL ELECTRICAL CODE, ANSI/NFPA No. 70-1984.

INSTALLATION

PROVISIONS MUST BE MADE FOR ADEQUATE AIR SUPPLY TO THE UNIT.

VENTILATING HOOD

The range(s) must be installed under a properly designed ventilating hood. The hood should extend at least 6" beyond all sides of the unit. The hood should be connected to an adequate mechanical exhaust system.

Information on the construction and installation of ventilating hoods may be obtained from the "Standard for the Installation of Equipment for the Removal of Smoke and Grease Laden Vapors from Commercial Cooking Equipment", NFPA No.96-1987 available from the National Fire Protection Association, Batterymarch Park, Quincy, MA 02269.

It is also necessary that sufficient room air ingress be allowed to compensate for the amount of air removed by the ventilating system. Otherwise, a subnormal atmospheric pressure will occur which may interfere with burner performance or may extinguish the pilot flame. In case of unsatisfactory range performance, check with the exhaust fan in the "OFF" position.

CLEARANCES

Adequate clearance must be provided in aisle and at the side and back to allow the doors to open sufficiently to permit the removal of the racks and for serviceability. Adequate clearance for air openings into the combustion chamber must be provided.

| CLEARANCES | | |
|--|-------------------------------------|--|
| | COMBUSTIBLE CONSTRUCTION | NONCOMBUSTIBLE CONSTRUCTION |
| BACK | 2" | 2" |
| LEFT & RIGHT SIDE | *6" | 0" |
| WITH 4" OR 6" LEGS: SUITABLE FOR INSTALLATION ON COMBUSTIBLE FLOORS. | | |
| *15" WHEN EQUIPPED WITH OPTIONAL 30,000 BTU/HR EACH OPEN TOP BURNER(S). | | |

CAUTION
DO NOT OBSTRUCT THE FLOW OF COMBUSTION AND VENTILATION AIR TO THE RANGE. KEEP THE APPLIANCE AREA FREE AND CLEAR FROM COMBUSTIBLES.

ASSEMBLY

Uncrate range as near to final location as possible. Remove all shipping wire from burners and all packing material and accessories from oven interior. Then assemble as follows:

1. Screw the adjustable feet of the legs in all the way. Then tightly screw the complete leg assembly into the mounting holes at each corner of the range.

INSTALLATION

2. Install door handle and secure with screws that are provided. Observe "UP" marking on handle for correct orientation.
3. If top castings are removed, identify castings so they are replaced in the same position and on same range as when received from the factory.

SETTING IN PLACE

BATTERY ARRANGEMENT:

1. Place the first range in the exact position it will occupy in the battery.
2. Using a carpenter's level, level range from front to rear and side to side. Adjust as follows:
FLOOR INSTALLATION ON LEGS: Adjust by turning foot on adjustable leg.
3. Remove the upper valve panel from range.
4. Move next range into position.
5. Engage union nut on manifold with male fitting on next range and draw up union nut hand tight. Be sure appliances butt together both front and rear. If manifolds do not align, then ranges are not level. In extreme cases, it may be necessary to loosen manifold bolts and adjust.
6. Continue leveling and connecting gas supply manifolds together until all appliances in battery are connected.
7. Tighten manifold unions gas tight. Use back up wrench to prevent manifold from rotating. FAILURE TO DO THIS MAY RESULT IN DAMAGE TO PILOTS AND GAS VALVES.

FRY TOP RANGES:

Fry Top Plate Adjustment: Leveling bolts are at the rear of the range under the fry top plate. Adjust leveling bolts so that the plate is pitched to the front to provide for grease runoff. (See Fig. 1).

HIGH SHELVES AND SALAMANDER BROILER: Lift high shelf or broiler above the range and slide legs into position. (See Fig. 2).

INSTALLATION

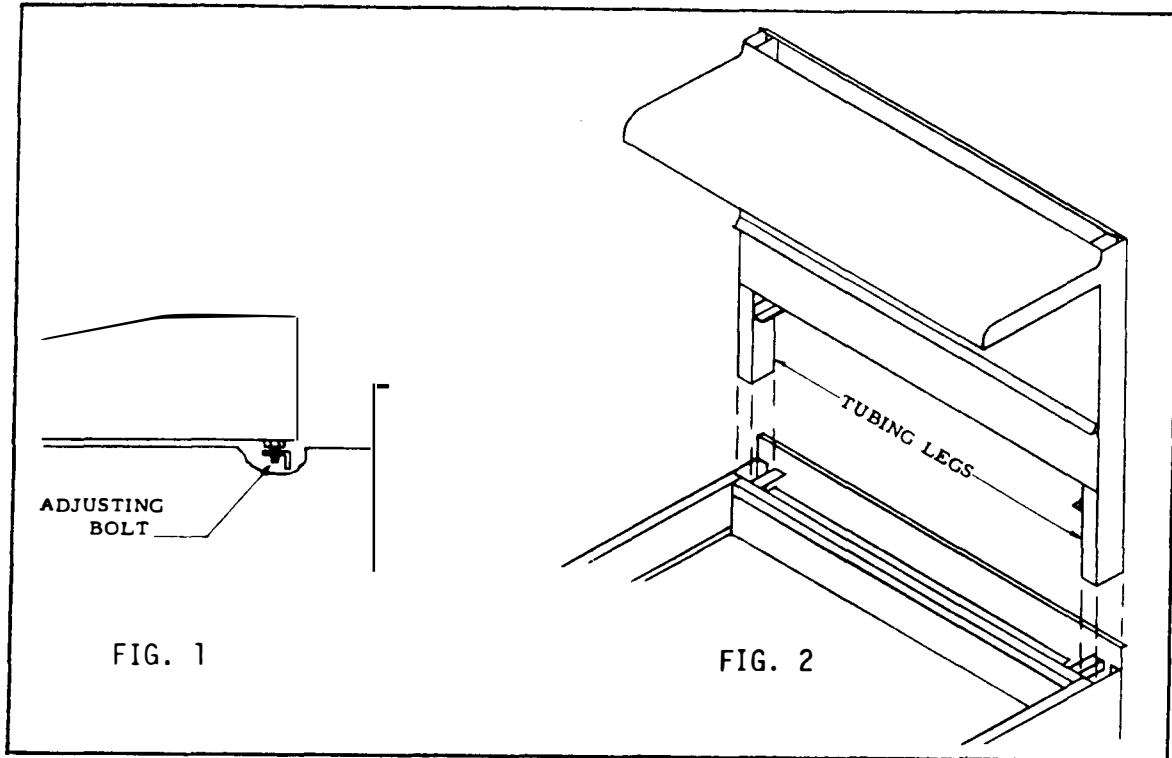

GAS APPLIANCE REGULATOR

A GAS APPLIANCE PRESSURE REGULATOR SUITABLE FOR THE BATTERY APPLICATION AND ADJUSTED FOR THE MANIFOLD PRESSURE SPECIFIED ON THE RANGE NAMEPLATE MUST BE FURNISHED BY THE INSTALLER AT THE TIME OF INSTALLATION.

Unless otherwise specified, the range is equipped with fixed orifices for use with a manifold pressure of 4.0" water column for natural gas and 10.0" water column for propane gas.

The gas pressure regulator furnished by the installer must comply with the following:

1. The pressure regulator(s) must have a maximum regulation capacity for the total connected load.
2. The pressure regulator(s) installed must be listed by a nationally recognized testing agency.
3. The pressure regulator(s) must have a pressure adjustment range to allow adjustment to the manifold pressure on the appliance rating plate.
4. Unless the manifold pressure on all connected appliances is the same, a separate pressure regulator must be supplied for each appliance(s) having differing manifold pressures.

INSTALLATION

GAS CONNECTION

Before connecting the range battery to the gas supply line, be sure that all new piping has been cleaned and purged to prevent any foreign matter from being carried into the controls by the gas. In some cases, filters or drops are recommended. A separate Gas Shut Off Valve must be installed upstream from the gas pressure regulator adjacent to the range battery and located in an accessible area.

WARNING: CAP ALL UNUSED OPEN ENDS OF THE GAS SUPPLY MANIFOLD.

It is important that adequately sized piping be run directly to the point of connection at range battery with as few elbows and tees as possible. Consult local gas company for proper piping size and gas pressure.

PIPE JOINT COMPOUND OR THREAD SEALANT THAT IS USED SHOULD BE RESISTANT TO ACTION OF LIQUEFIED PETROLEUM GASES.

Turn Gas Shut Off Valve "ON" and immediately check carefully for gas leaks. Do this before attempting to operate the range battery.

TEST ALL PIPE JOINTS FOR LEAKS BEFORE OPERATING RANGE(S). THIS INCLUDES ALL GAS CONNECTIONS THAT MAY HAVE LOOSENED DURING SHIPMENT. USE A RICH SOAP SOLUTION (OR OTHER ACCEPTED LEAK TESTER) AROUND ALL PIPE CONNECTIONS AND ALL OTHER JOINTS. DO NOT USE AN OPEN FLAME. ABSOLUTELY NO LEAKAGE SHOULD OCCUR, OTHERWISE THERE IS A DANGER OF FIRE OR EXPLOSION DEPENDING UPON CONDITIONS. NEVER USE IF LEAKAGE IS DETECTED.

ELECTRICAL CONNECTION

Unless otherwise specified, the range is equipped with a 6 ft. flexible supply cord for 115 VAC, 60 Hertz. A terminal block is provided for 208-240 VAC, 60 or 50 Hertz, single phase units. The wiring diagram is located on the back of the range.

THIS APPLIANCE, WHEN INSTALLED, MUST BE ELECTRICALLY GROUNDED IN ACCORDANCE WITH LOCAL CODES, OR IN THE ABSENCE OF LOCAL CODES, WITH THE NATIONAL ELECTRICAL CODE, ANSI/NFPA NO. 70-1984.

I. 115 VAC - 60 Hz - Single Phase

Ranges with this electrical rating are factory supplied with a three-wire cord and three-prong plug which fits any standard three-prong grounded receptacle. A separate 15 amp. supply is needed for each oven.

INSTALLATION

WARNING: ELECTRICAL GROUNDING INSTRUCTIONS

THIS APPLIANCE IS EQUIPPED WITH A THREE-PRONG (GROUNDING) PLUG FOR YOUR PROTECTION AGAINST SHOCK HAZARD AND SHOULD BE PLUGGED DIRECTLY INTO A PROPERLY GROUNDED THREE-PRONG RECEPTACLE. DO NOT CUT OR REMOVE THE GROUNDING PRONG FROM THIS PLUG.

II. 208-240 VAC - 60 Hz - Single Phase (2 wire)

Ranges with this electrical rating are factory equipped with a terminal block. To connect supply wires, remove cover from connection box at right rear of range. Route supply wires and ground wire through hole with strain relief fitting at top of connection box. Attach supply wires to proper terminal of terminal block. Attach ground wire to ground lug inside connection box. See wiring diagram for proper connection.

III. 220 VAC - 50 Hz - Single Phase (2 Wire)

Follow steps outlined in (II.) above, Refer to wiring diagram for proper connection

PILOT ADJUSTMENT - TOP BURNERS (See Figure 3)

OPEN TOP: The front and rear pilots are controlled by one valve. To adjust pilot, turn adjusting screw counter-clockwise to increase or clockwise to decrease pilot flame. Adjust flame to a point where only a trace of yellow tip remains.

HOT TOP & FRY TOP: Each pilot is controlled by a pilot valve. Turn adjusting screw until pilot flame is 1/2" high.

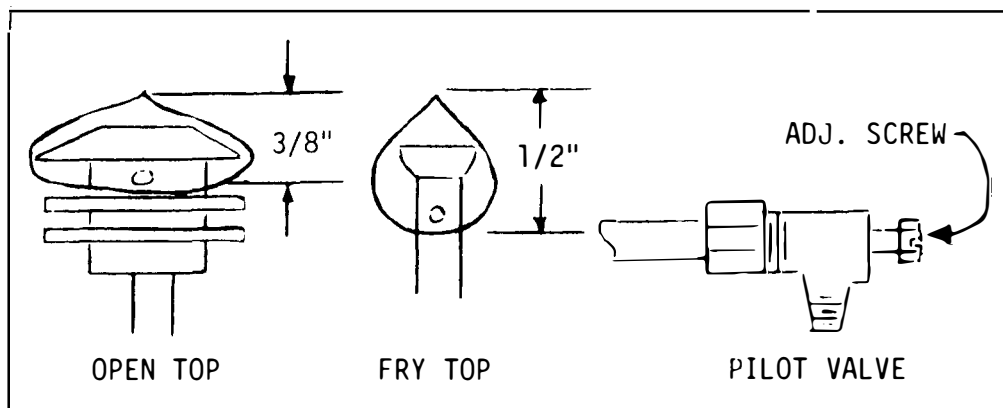

FIGURE 3

INSTALLATION

BURNER ADJUSTMENT

The efficiency of the range depends on a delicate balance between the supply of air and volume of gas so that complete combustion is achieved. Whenever this balance is disturbed, poor operating characteristics occur.

The air supply is controlled by an air shutter on the front of the burner. The air shutter opening should be increased until the flame on the burner begins to "lift". The air shutter should then be closed slightly and locked in place. A yellow streaming flame indicates insufficient air. This condition can be corrected by increasing the air shutter opening.

FRY TOP AND OVEN THERMOSTATS

The bypass (minimum burner flame) has been adjusted at factory and should require no further adjustment if the gas manifold pressure is correct.

THE BYPASS FLAME MUST BE RECHECKED WHEN PERFORMING CHECKOUT OF RANGE PRIOR TO PLACING EQUIPMENT IN SERVICE. THE BYPASS MUST BE SET CAREFULLY AND ACCURATELY. REFER TO SERVICE SECTION OF THIS MANUAL FOR PROPER PROCEDURE.

OPERATION

OPERATING INFORMATION FOR THE RANGE HAS BEEN PREPARED FOR USE BY QUALIFIED AND/OR PROFESSIONAL OPERATING PERSONNEL.

CAUTION

DO NOT OBSTRUCT THE FLOW OF COMBUSTION AND VENTILATION AIR TO THE RANGE. KEEP THE APPLIANCE AREA FREE AND CLEAR FROM COMBUSTIBLES.

GAS CONTROLS

IN THE EVENT A GAS ODOR IS DETECTED, SHUT DOWN UNITS AT MAIN SHUT OFF VALVE AND CONTACT THE LOCAL GAS COMPANY OR GAS SUPPLIER FOR SERVICE.

TOP BURNERS- OPEN, HOT TOP AND MANUAL FRYTOP

Check that pilots are burning. Then rotate valve handles counter clockwise to full on, burner will ignite automatically. Adjust flame height as desired. To shut down, rotate valve handle clockwise to "OFF" position.

FRY TOP- THERMOSTAT CONTROLLED

Check that pilot(s) are burning. Then push thermostat dial inward and rotate dial counter-clockwise to maximum thermostat setting, burner(s) will ignite automatically. After ignition, turn thermostat dial to desired setting. To shut down, rotate thermostat dial clockwise to "OFF" position.

OVEN

A. Lighting

Turn burner valve to "OFF" position and wait five (5) minutes.

1. Remove burner compartment cover and open pilot access door.
2. Press and hold red button in (Safety Pilot Valve) and apply lighted match to pilot burner.
3. After pilot burner ignites, continue to hold red button depressed for 30 to 45 seconds or until pilot remains burning when button is released. If pilot goes out, repeat process.

OPERATION

4. After pilot burner ignites, continue to hold red button depressed for 30 to 45 seconds or until pilot remains burning when button is released. If pilot goes out, repeat process.
5. Close pilot access door and replace burner access panel.
6. Turn burner valve on and rotate thermostat dial counter-clockwise to desired temperature setting.
7. Turn on fan. Fan should be on at all times during cooking operation.
8. IN THE EVENT OF PILOT FAILURE, TURN BURNER VALVE CLOCKWISE TO "OFF" POSITION AND WAIT FIVE (5) MINUTES FOR UNBURNED GAS TO ESCAPE FROM RANGE.

B. Shut Down

1. Stand by
 - a. Turn oven burner valve to "OFF" position.
 - b. Turn fan off.
2. Complete
 - a. Turn all gas valves to "OFF" position.
 - b. Turn fan off.
 - c. Turn electrical service off or disconnect electrical supply cord from wall receptacle.

C. Relighting

1. Turn oven burner valve to "OFF" position.
2. Wait five (5) minutes then follow "lighting" instructions in Section "A".

USING A CONVECTION OVEN

Your modern gas convection oven assures speedy cooking and quality performance. It's proper use will result in gas energy conservation.

The convection oven is a different type of oven which offers many features and advantages to the food service operation. The operation of the oven is not difficult to understand or control.

The convection oven is the sealed type whereby the combustion products are separated from the air inside the oven. The heat is transferred thru the oven surface into the cavity. The air inside the oven is continuously recirculated over the heat source and the product.

The moving air strips away the insulating layer of moisture on the products allowing heat to penetrate faster for quicker baking and roasting. Due to these differences in the methods of cooking in a convection oven,

OPERATION

procedures and techniques may require some modification for successful results. A general rule which will assist in better operation, is cooking time will be less and temperatures should be 25 to 75 degrees lower than those called for in standard recipes.

| For convection oven cooking, reduce temperature 25 to 75 degrees from those given in standard recipes. | | |
|---|-----------------------------|----------------------|
| Type of Food | Reduction in Temperature | Reduction in Time |
| Baked Products | | |
| Cookies | 25° | 1/4 to 1/3 |
| Cakes & Quick Bread | 50° | 1/4 to 1/3 |
| Yeast Products | 75° | 1/4 to 1/3 |
| Casseroles | 25° | 1/4 to 1/2 |

COOKING HINTS

| GUIDE TO TIME AND TEMPERATURES | | |
|--------------------------------|---------------------------|------------|
| PRODUCT | TEMPERATURES (DEGREES) | TIME |
| BREAD, BAKERY | | |
| Bread (24-1 Lb. loaves) | 340 | 30 Min. |
| Hamburger Rolls | 300 | 15 Min. |
| Corn Bread (Northern) | 335 | 25 Min. |
| Corn Bread (Southern) | 375 | 15-20 Min. |
| Yeast Rolls | 325 | 25 Min. |
| Baking Soda Biscuits | 400 | 6 Min. |
| Cinnamon Buns | 335 | 20 Min. |
| Danish | 335 | 12 Min. |
| Brownies | 300 | 18 Min. |
| Cream Puffs | 350 | 20-25 Min. |
| Sugar Cookies | 300 | 15 Min. |
| Chocolate Chip Cookies | 275 | 8-10 Min. |
| Sheet Cakes (5 lb./1 pans) | 325 | 16-18 Min. |
| Chocolate Cake | 325 | 20 Min. |
| Angel Food Cake | 250 | 25-30 Min. |
| Fruit Cakes | 275 | 70 Min. |
| Pie Shells | 350 | 12 Min. |
| Frozen Berry Pies(20 oz.) | 350 | 35 Min. |
| Frozen Fruit Pies(46 oz.) | 350 | 45-50 Min. |
| Fruit Cobbler | 375 | 25 Min. |
| Fresh Apple Pies(20 oz.) | 350 | 25-30 Min. |
| Pumpkin Pies | 275 | 30-35 Min. |
| Custard Pies | 250 | 25-30 Min. |
| Meringue Pies | 350 | 4 Min. |
| Apple Turnovers | 350 | 20 Min. |
| Fruit Crisp | 300 | 25 Min. |
| Pizza (13") | 475 | 6 Min. |
| MEAT, POULTRY, FISH | | |
| Hamburger Patties | 400 | 8 Min. |
| Meat Loaf | 325 | 40-45 Min. |
| Prime Rib (20 lbs.) | 250 | 2-½ Hrs. |
| Roled Beef Roast (12-15 lbs.) | 250 | 2-½ Hrs. |
| Steamship Round (80 lbs.) | 275 | 2-¾ Hrs. |
| Steaks - New York | 450 | 7 Min. |
| Steaks - Salisbury | 300 | 20 Min. |
| Boned Veal Roast (15 lbs.) | 300 | 3 Hrs. |
| Stuffed Pork Chops | 375 | 25-30 Min. |
| Lamb Chops (Sm. Loin) | 400 | 6 Min. |
| Fish Sticks | 335 | 16-18 Min. |
| Halibut Steaks (Frozen) | 350 | 20 Min. |
| Lobster Tails (Frozen) | 425 | 7 Min. |
| Stuffed Lobster | 400 | 6-7 Min. |
| Stuffed Shrimp | 400 | 6-7 Min. |
| Chicken Breast & Thigh | 325 | 40 Min. |
| Chicken(2½ lbs. Quartered) | 325 | 30 Min. |
| Turkey, Rolled (18 lbs.) | 310 | 3-½ Hrs. |
| Chicken-Turkey Pot Pies | 400 | 30-35 Min. |
| MISCELLANEOUS | | |
| Idaho Potatoes (120 ct.) | 400 | 50 Min. |
| Lasagna | 250 | 90 Min. |
| Stuffed Peppers | 350 | 15-20 Min. |
| Hot Dogs | 300 | 10-15 Min. |
| Melted Cheese Sandwiches | 400 | 8 Min. |
| Macaroni and Cheese | 350 | 15-20 Min. |

COOKING HINTS

BAKING DIFFICULTIES & PROBABLE CAUSES (Cont.)

UNEVEN BAKES

1. Insufficient heat input.
2. Warped pans.
3. Warped oven racks.
4. Uneven loading of pan or pans.
5. Fan Off.
6. Oven not level causing dough to run to side or rear of pan.

SPOTTY PIE BOTTOMS

1. Overworked pastry.

SPOTTY BREAD

1. Overworked dough.

BURNED GOODS, CRIPPLES

1. Incorrect temperature.
2. Thermostat out of calibration.
3. Left in too long.
4. Improper scaling.

DRIED OUT GOODS

1. Too low temperature.
2. In oven too long.
3. Improper mix.

ALTERNATELY GOOD AND POOR RESULTS

1. Fan off and on.
2. Improper scaling and control of ingredients.

TOPS DARK, CENTER NOT DONE

1. Too high temperature

SIDE BURNING

1. Oven not level.
2. Uneven loading.

LACK OF UNIFORMITY - SAME PAN

1. Uneven loading in pan. (See uneven bakes)
2. Faulty pans.

LACK OF SPRING

1. Overproofing.
2. Incorrect temperature.

BAKING DIFFICULTIES & PROBABLE CAUSES (Cont.)

CRACKED CAKES

1. Too high temperature.
2. Too fast cooling.

UNDERDONE PIE BOTTOMS (ADVISABLE TO BAKE ON COOKIE SHEET)

1. Pastry too rich.
2. Pastry too thick.
3. Warped pie tins (When used on cookie sheet)

HEAVILY COLORED PIE RIMS

1. Air bubbles enclosed in pastry when crimped.

UNEVEN BAKED COOKIES

1. Not scaled properly.
2. Pans warped.

MAINTENANCE

CAUTION

DISCONNECT POWER BEFORE CLEANING OR SERVICING. EACH OVEN SECTION HAS A SEPARATE ELECTRICAL SUPPLY CONNECTION.

CARE AND CLEANING

The complete range should be given a periodic general cleaning. Lint and grease suspended in the air tend to collect in passages. Therefore, all flueways, air passages and openings, burner ports, primary air openings, etc. should be periodically cleaned to prevent clogging.

EXTERIOR

PAINTED SURFACE: Allow equipment to cool after use and wash with a mild detergent or soap solution. Dry thoroughly with a dry cloth.

STAINLESS STEEL SURFACE: To remove dirt, grease, or product residue, from stainless steel use ordinary soap and water (with or without detergent) applied with a sponge or cloth. Dry thoroughly with a clean cloth.

To remove grease and food splatter, or condensed vapors, that have baked on the equipment apply cleanser to a damp cloth or sponge and rub cleanser on the metal in the direction of the polishing lines on the metal. Rubbing cleanser as gently as possible in the direction of the polished lines will not mar the finish of the stainless steel. NEVER RUB WITH A CIRCULAR MOTION. Soil and burnt deposits which do not respond to the above procedure can usually be removed by rubbing the surface with SCOTCH-BRITE scouring pads or STAINLESS scouring pads. DO NOT USE ORDINARY STEEL WOOL as any particles left on the surface will rust and further spoil the appearance of the finish. NEVER USE A WIRE BRUSH, STEEL SCOURING PADS (EXCEPT STAINLESS), SCRAPER, FILE OR OTHER STEEL TOOLS. Surfaces which are marred collect dirt more rapidly and become more difficult to clean. Marring also increases the possibility of corrosive attack.

To remove heat tint: Darkened areas sometimes appear on stainless steel surfaces where the area has been subjected to excessive heat. These darkened areas are caused by thickening of the protective surface of the stainless steel and are not harmful. Heat tint can normally be removed by the foregoing, but tint which does not respond to this procedure calls for a vigorous scouring in the direction of the polish lines, using SCOTCH-BRITE scouring pads or a STAINLESS scouring pad in combination with a powdered cleanser. Heat tint action may be lessened by not applying or by reducing heat to equipment during slack periods.

OVEN INTERIOR

STANDARD FINISH (Porcelain Enamel): Frequent cleaning is required. Spillovers should be cleaned as soon as possible to prevent carbonizing and a burnt on condition. Wait until oven is cool for complete cleaning. Usually a soap or detergent solution is strong enough to remove any grease residue. A mild abrasive nylon cleaning pad may be used for stubborn spillovers or stains. Commercial oven cleaners may be used; however, do not allow cleaners to come in contact with the thermostat capillary tube.

MAINTENANCE

CONTINUOUS CLEAN FINISH: It is readily identified by its dark brown and white speckled finish. This coating is endowed with a unique cleaning ability that causes food and grease splatters to gradually clean away automatically when exposed to normal oven temperature.

Each day, after baking and roasting operations have been completed, empty the oven. Then turn the temperature control up to high heat. This high heat will speed up the cleaning action and reduce the time required to clean the oven effectively. The cleaning time necessary will depend upon the "soil" condition in the oven. As a general rule, allow from 45 to 60 minutes.

When the oven appears soiled due to heavy staining, we suggest preheating the empty oven each day for one to two hours for most effective results. Also, ordinary household ammonia has proved an effective method for removing baked-on build-up, and in keeping the microscopic pores of the coating open and free to perform its cleaning action. Thus, an occasional light swabbing with household ammonia while oven is at room temperature can prove to be extremely beneficial.

Excessive spillage or crust which is allowed to build up on oven interior surfaces will seriously retard the continuous cleaning action. It should be wiped away as soon as possible with a damp cloth.

Although the oven may appear clean, we recommend operating the oven at high heat for approximately two hours once every month. This will prevent build-up of solids in hard-to-see places or in the pores of the coating. Caution: Never use abrasives, powders, harsh liquids, caustics or dyes as they may leave a film or residue that will clog the pores of the special coating, and retard the cleaning action.

Certain types of food may leave a stain that is slow to fade. These include flour-milk mixtures, sugar, macaroni and cheese, cream sauces, and blood. It may take a slightly longer time for the continuous cleaning action to clean this type of stain. Accelerate removal by using household ammonia while oven is at room temperature.

If excessive soils or spillovers have become carbonized, remove the charred portion with a hard nylon brush. (Do not use steel or other metallic brushes or scouring pads.) For any stubborn stain or "varnish" film, apply a good grade paste oven cleaner in the following manner:

- (1) With the oven at room temperature, apply paste over the spill.
- (2) Allow to stand for 10-15 minutes (read instructions on label of product); then wipe up spill.
- (3) Reapply if not entirely removed (any film remaining over top of material will prevent self-cleaning action.)
- (4) If necessary, apply Montague Oven Cleaner with a hard nylon brush.
- (5) Remove loosened particles with a damp cloth. Note: Steam may be used where it is available. It is not harmful to the special coating.

Always be sure to wipe up any excess water.

OPEN TOP SECTION

DAILY: Wipe top with burlap or other grease absorbing material to remove spillovers, grease, etc., before they burn in.

MAINTENANCE

WEEKLY: Open Top Section should be washed in a solution of washing soda and water (after they are entirely cooled). Remove and wash drip pan under burners. Brush burner head weekly with a stiff wire brush and clean clogged ports with stiff wire or ice pick. Excessive grease build up may be removed from burners by soaking in a solution of washing soda. Dry burners by inverting on oven rack in a low temperature oven.

HOT TOP SECTION

Daily: Wipe top with heavy burlap or steel wool, rub briskly until clean. Lift rings and plates to clean all flanges and under lid. NEVER POUR WATER ON A HOT TOP SECTION.

FRY TOP SECTION

DAILY: Use flat edge of spatula or metal scraper to keep surface free of encrusted material during use, wipe frequently with heavy absorbent cloth. After griddle is cooled, polish with soft griddle stone or a good grade grill pad. DO NOT SCRATCH. The griddle may be washed with warm water and a cleanser. Water will not crack this griddle plate.

To oil the griddle, use a hydrogenated shortening. Never use salad oils, margarine or butter, as these shortenings cannot withstand temperatures greater than 300°F.

ELECTRIC MOTOR

The electric motor has been specially manufactured for this blower application and should give years of trouble-free service under normal conditions.

The unit is supplied with permanently lubricated sealed bearings which require no additional lubrication. A high temperature grease has been used to increase bearing life and should only be replaced by an authorized service station.

The motor is of an open drip-proof type construction, and as such, care should be given to see that the ventilation openings remain clear.

The motor is equipped with built-in automatic thermal overload protection to prevent damage from overheating.

If problems do develop with the motor, contact your nearest authorized service station.

| |
|--|
| CAUTION: CARE SHOULD BE USED WHEN WASHING DOWN EQUIPMENT TO KEEP WATER AND CLEANING SOLUTIONS OUT OF THE MOTOR OR DAMAGE WILL OCCUR. |
|--|

WHEN SERVICE IS NEEDED, CONTACT A LOCAL SERVICE COMPANY, DEALER, OR FACTORY TO PERFORM MECHANICAL MAINTENANCE AND REPAIRS. THESE INSTRUCTIONS ARE INTENDED FOR USE BY COMPETENT SERVICE PERSONNEL.

CAUTION: DISCONNECT POWER BEFORE DOING ANY SERVICE WORK. EACH OVEN SECTION HAS SEPARATE ELECTRICAL SUPPLY CONNECTION. TURN OFF GAS SUPPLY WHEN SERVICING GAS CONTROL SYSTEM.

SAFETY PILOT VALVE

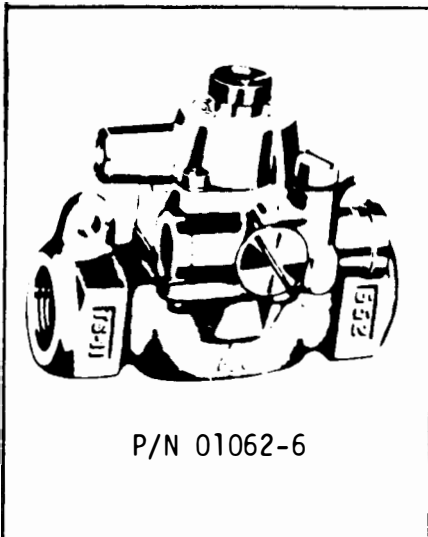

Model TS-11J is an automatic 100% safety pilot which provides complete gas shut off in event of pilot failure. The safety valve is held closed by spring pressure. When red button is pushed by hand, gas flows to pilot. Pilot heats thermocouple creating a very small amount of electricity. This energizes a magnetic coil under red button and holds valve open, permitting gas to flow to main burner and pilot without holding pressure on red button. In the event of pilot failure, the flow of electricity will stop and spring will stop flow of gas to both pilot and oven burner.

OVEN PILOT BURNER

PILOT SERVICE IN THE EVENT OF PILOT FLAME FAILURE

1. If pilot flame burns yellow, clean pilot orifice and pilot burner to insure a steady blue flame. The orifice can be cleaned by washing in a solvent such as trichloroethylene and/or blowing out with air.
2. Flame must surround the thermocouple tip for approximately 1/2 inch.

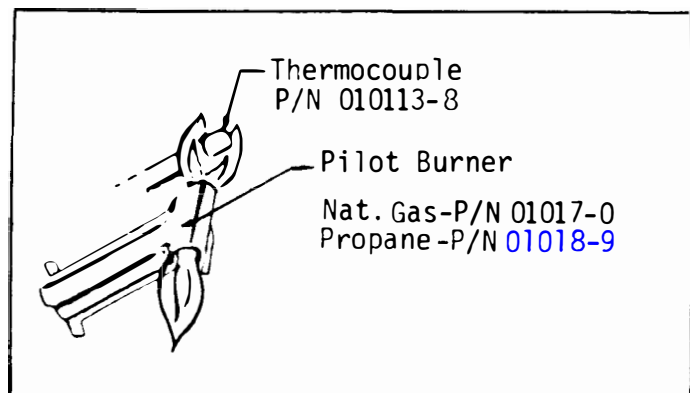

SERVICE

If the closed circuit check shows thermocouple output is greater than 8 millivolts and pilot will not remain lit when reset button is released, replace safety pilot magnet assembly.

THERMOCOUPLE OUTPUT

| CLOSED CIRCUIT MV RANGE | |
|----------------------------|---------------|
| NORMAL | NOT LESS THAN |
| 15 - 25 | 8 |

3. Thermocouple lead connections must be tight, clean, and free of grease. The thermocouple nut should be started and turned all the way by hand. An additional quarter turn with a small wrench will then be sufficient.

CAUTION: OVERTIGHTENING MAY CAUSE DAMAGE TO THE THERMOCOUPLE OR MAGNET AND IS UNNECESSARY SINCE THIS IS AN ELECTRIC CONNECTION.

FRY TOP THERMOSTAT

The Model BJ Robertshaw is a combination thermostat and gas valve. The gas is turned on and the temperature setting made by a single rotation of the dial. This valve automatically locks itself in the OFF position. To use, push dial inward, rotate counter-clockwise to the desired temperature. To shut gas off, rotate clockwise to OFF position.

The thermostat is a precision instrument carefully made and properly calibrated (i.e. the dial is properly set) at the factory to control temperatures accurately. It should control temperatures for the proper cooking of food without recalibration. The calibration of this thermostat should not be changed until considerable experience with cooking results has definitely proved that the thermostat is not maintaining the proper temperature.

CAUTION: THE RECALIBRATION SHOULD NOT BE MADE UNTIL THE BYPASS (MINIMUM BURNER) FLAME HAS BEEN PROPERLY ADJUSTED.

THERMOSTAT INSTALLATION

With front of the griddle plate raised, slide the thermostat bulb assembly into the support brackets attached to the underside of the fry top plate. Tighten the two holding screws. The excess capillary tube should be pulled forward and down as low as possible out of the heat zone, so that there is no chance of it coming in contact with the burner flame. Push the sleeving up against the bulb holder. A loose fit between the bulb holder and plate may damage the thermostat so that it will not control the temperature of the fry top plate.

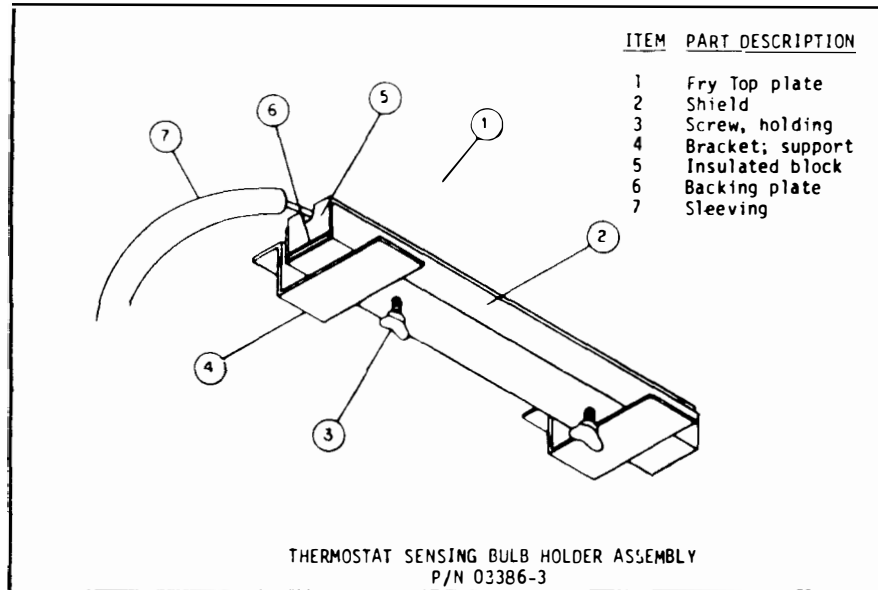

ADJUSTMENT OF BYPASS (MINIMUM BURNER) FLAME

This is the flame which must be maintained on the burners when the fry top has reached the temperature set on the dial. Enough gas must be bypassed by the control to keep the entire burner lit. The thermostat regulates the flame from high to low in accordance with the fry top temperature and will automatically turn down to this bypass flame when the temperature set on the dial is attained.

Special care should be taken to see that the thermostat bulb is in its proper place and no part of the capillary tube is in any flame or heat zone. The fry top plate should never be removed without first removing the thermostat bulb(s) from beneath the plate. Never allow capillary tube to be kinked or crushed.

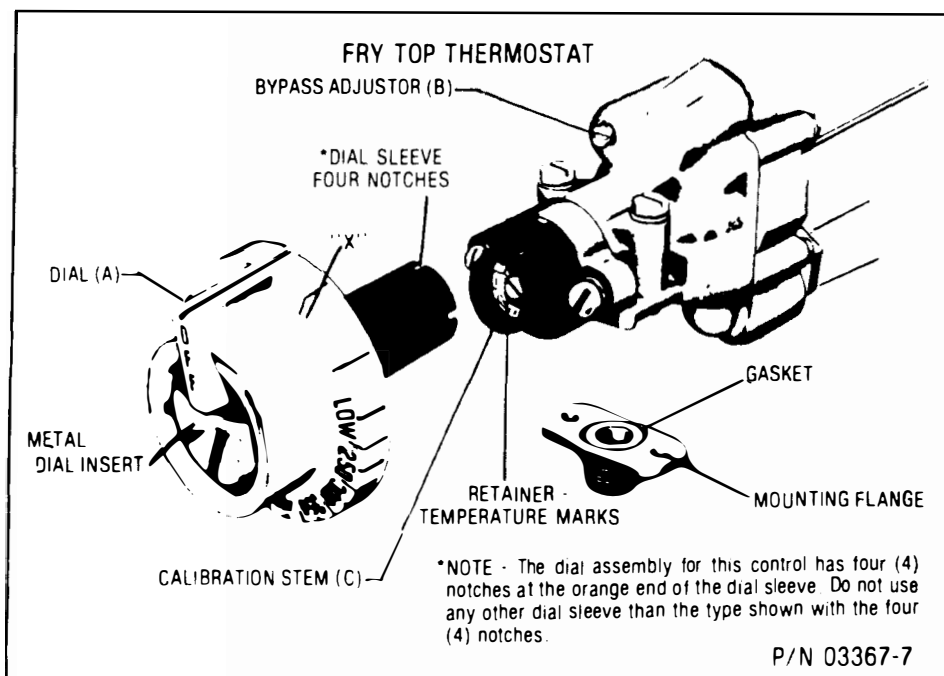

SERVICE

THE BYPASS MUST BE SET CAREFULLY AND ACCURATELY AS FOLLOWS:

1. Light burners and turn Dial (A) counterclockwise and to a point midway between the "Gas On" mark and the next graduation to the right of it (shown by "X"). If the burner goes out entirely, the bypass is closed.
2. Slip off Dial (A). Remove the valve panel from the front of the range.
3. With a screwdriver turn bypass adjustor (B). Turning it out counterclockwise increases the bypass flame; turning it in clockwise decreases the bypass flame. Adjust until there is a flame approximately 1/8" high over the entire burner.
4. Replace dial, rotating dial clockwise until it snaps into its original position.
5. Reinstall the valve panel on front of the range.

FRY TOP THERMOSTAT CALIBRATION CHECK:

The fry top temperature should be checked or recalibrated with fry top hot. NOTE: See "Adjustment of Bypass (Minimum Burner) Flame" before recalibrating this thermostat.

HOT CHECK METHOD:

1. Place reliable thermometer in center of the top of the fry top over the thermal bulb.
2. Set Dial (A) to 350°.
3. Wait until temperature rises and remains constant.
4. If dial does not agree with thermometer readings, slip off Dial (A) and push out metal insert.
5. Replace dial, turn to 350° mark.
6. Hold dial firmly, insert screwdriver through center of dial and push calibration stem (C) inward. DO NOT TURN THIS STEM.
7. While holding calibration stem (C) in firmly with screwdriver, turn dial until it is set at the actual fry top temperature as shown by the thermometer. Release pressure on calibration stem. Replace dial insert.

OVEN THERMOSTAT

All adjustments are accessible from the front of the range after the dial and the front panel have been removed. To remove the dial, grasp

SERVICE

knob portion firmly and pull. This will expose the calibration plate. Dial is held to the shaft with a friction fit. There are no screws.

Field recalibration is seldom necessary, and should not be resorted to unless experience with cooking results definitely proves that the control is not maintaining the temperature to which the dial is set. To check oven temperatures when recalibrating use a Robertshaw Test Instrument or a reliable mercury oven thermometer.

CAUTION: THE RECALIBRATION SHOULD NOT BE MADE UNTIL THE BYPASS (MINIMUM BURNER) FLAME HAS BEEN PROPERLY ADJUSTED.

ADJUSTMENT OF BYPASS (MINIMUM BURNER FLAME)

Enough gas must be bypassed through the heat control to keep the entire burner lit while in use. The control regulates the flame from high to low.

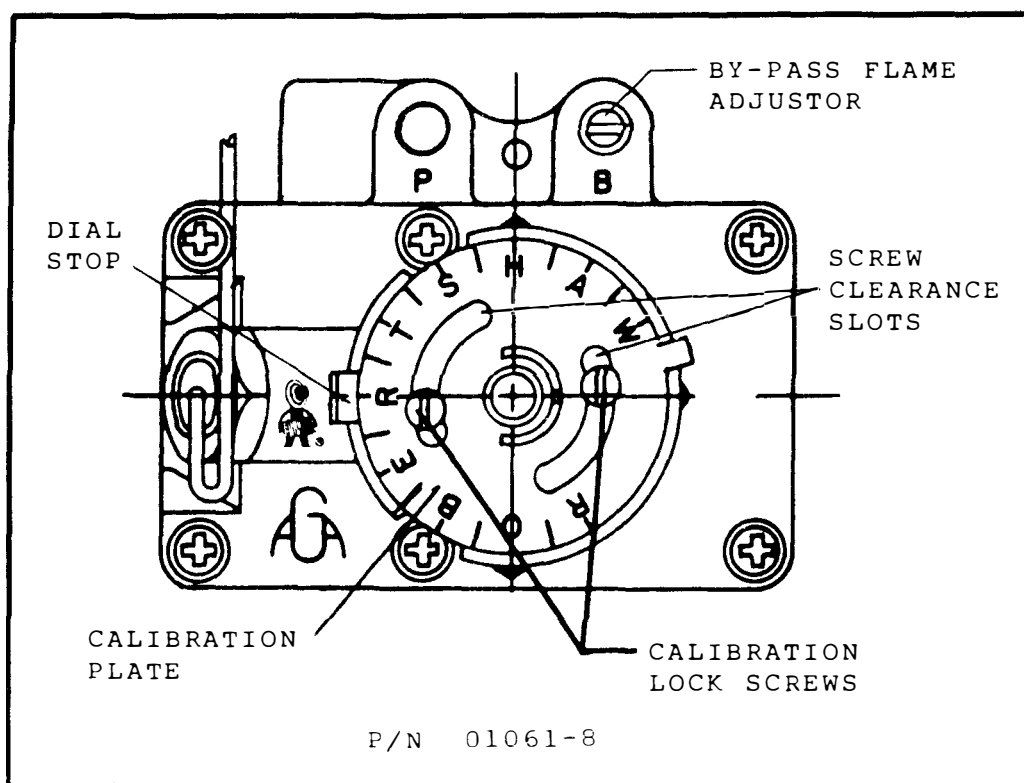

PROCEDURE:

1. Turn dial to 300 degrees F.
2. Light main burner.
3. After oven temperature rises and remains constant turn dial back to low. This closes main valve and permits only the bypass gas to the burner.

SERVICE

4. Remove dial.
5. With a screwdriver, turn the bypass flame adjustor screw counter-clockwise to increase the bypass flame or clockwise to decrease it until the flame over the entire burner is approximately 1/8" high. Replace dial.

THERMOSTAT CALIBRATION CHECK:

1. Place the thermocouple of test instrument or thermometer in the middle of the oven.
2. Light the main burner.
3. Turn dial so 400 lines up with the indicator mark on dial stop.
4. Allow the oven to heat until flame cuts down to bypass. After sufficient time, check temperature. If the temperature does not read within 15 degrees of the dial setting, recalibrate as follows:
 - A. Pull dial straight off without turning.
 - B. Hold calibration plate and loosen the two calibration lock screws until the plate can be moved independently of the control.
 - C. Turn calibration plate so that the instrument or thermometer reading is in line with the indicator mark. Hold plate and tighten screws firmly. On controls where the plate has no temperature markings use a chart to determine the temperature degrees between letters. Turn the calibration plate counter-clockwise if the test reading is higher than the dial setting, or clockwise if the reading is lower than the dial setting.
 - D. Replace dial.

NOTE: If the above adjustment is prevented by the two loosened calibration lock screws being in contact with the ends of the screw clearance slots in the calibration plate, remove the screws and after turning the calibration plate to the proper location, reassemble screws in the other tapped holes designed for them.

| RECALIBRATION CHART | | |
|----------------------------|---------------------------|-------------------------|
| Dial Range | °F Between Letters | Calibration Mark |
| 200 to 500 | 50° | 400 |

REMOVAL OF OVEN BURNER AND PILOT BURNER

CAUTION: Turn off gas at manual shut off valve next to the appliance BEFORE attempting to loosen any gas connections.

1. Close manual shut off valve.
2. Remove burner access panel.
3. Remove screws from front of burner compartment front. Put top of panel forward and lift out.
4. Disconnect thermocouple of pilot supply tubing from safety valve.
5. Lift rear portion of burner up so that lugs will clear burner compartment bottom and slide burner toward the rear until air mixer clears the orifice fitting.
6. Slide oven burner and pilot assembly out of the burner compartment. To reassemble, reverse above procedure.

NOTE: Periodically check the condition of the stainless steel flame baffle (P/N 06139-5). If baffle has deteriorated or is severely warped, it should be replaced before the burner flame damages the oven bottom.

GAS PRESSURE REGULATOR

WARNING

NO UNTRAINED PERSON SHOULD ATTEMPT TO MAINTAIN OR SERVICE THE GAS PRESSURE REGULATOR.

REMOVAL OF THE FLAME BAFFLE AND HEAT BAFFLE ASSEMBLY

1. Remove oven racks and left and right rack guides.
2. Remove fan baffle.
3. Remove four screws on each side and three screws on back of oven interior liner bottom.
4. Pry liner bottom up and pull forward to remove from oven.
5. Lift heat baffle up and remove.
6. Remove flame baffle.

To reassemble, reverse above procedure.

SERVICE

CAUTION: BEFORE REPLACING OVEN INTERIOR LINER BOTTOM, SEAL THE SIDE AND REAR FLANGES WITH FURNACE CEMENT TO PREVENT AIR LEAKS INTO COMBUSTION CHAMBER. AIR LEAKS INTO THE COMBUSTION CHAMBER COULD ADVERSELY AFFECT BURNER OPERATION.

REMOVAL OF MOTOR AND BLOWER WHEEL ASSEMBLY

CAUTION: DISCONNECT ELECTRICAL POWER TO RANGE BEFORE SERVICING.

1. Remove oven racks from oven interior.
2. Remove the four thumbscrews holding the fan baffle and remove fan baffle from oven.
3. Remove the ten nuts holding the motor mounting plate assembly to the back of the oven.
4. Pull plate forward so that motor flange clears 10" diameter cut out in oven back panel. The first time motor is removed, the 1/8" thick rectangular insulation pad between motor and oven back panel will have to be forced thru 10" diameter hole. Pull motor completely thru hole and rest on oven bottom.
5. Remove cover from junction box on motor and disconnect wire leads. (Mark wire leads for identification during reconnection.)
6. Disconnect flexible conduit from junction box. Motor, mounting plate and blower wheel may then be removed from the oven.

Blower Wheel Removal:

1. Loosen the two Allen set screws on the blower wheel hub.
2. Using a wheel puller, remove the blower wheel from the motor shaft. A flange on the blower wheel hub is provided for this purpose.

Motor Removal from the Mounting Plate:

Remove four nuts from motor mounting bolts and remove motor.

To reassemble, reverse the above procedure

IMPORTANT: WHEN INSTALLING BLOWER WHEEL ON MOTOR SHAFT, POSITION BLOWER WHEEL SO THAT IT WILL NOT RUB AGAINST BOLT HEADS ON MOUNTING PLATE OR CONTACT FAN BAFFLE.

MOTORS

One of the following is used on each oven:

| ELECTRICAL CHARACTERISTICS | | | | | | |
|----------------------------|------------|-----------|--------------|----------------|-----------|-----------|
| <u>PART NO.</u> | <u>MFR</u> | <u>HP</u> | <u>SPEED</u> | <u>VOLTAGE</u> | <u>HZ</u> | <u>PH</u> |
| 06265-0 | Howell | 1/4 | 1 | 115 | 60 | 1 |
| 06382-7 | Baldor | 1/4 | 1 | 115/230 | 60 | 1 |
| 02167-9 | Howell | 3/4 | 1 | 115/230 | 60 | 1 |
| 01402-8 | Baldor | 3/4 | 1 | 115/230 | 60 | 1 |

DOOR SWITCH

CAUTION: DISCONNECT ELECTRICAL POWER TO RANGE BEFORE SERVICING.

The switch should be adjusted so that when the door is opened one and one-quarter inch, the switch shuts off the blower. The switch is located behind burner access panel on right side next to the door post.

ADJUSTMENT

1. Loosen the two nuts on front of door switch bracket.
2. Turn back-up nuts inward to increase opening to 1-1/4 or turn back-up nuts outward to decrease opening. With no power on oven, the switch is adjusted by the sound of the switch clicking.

REPLACEMENT

1. Remove switch cover.
2. Carefully disconnect wires from switch.
3. Remove nuts from microswitch mounting screws.
4. Follow above steps in replacing parts in reverse order.

CAUTION: Check that washers are in place between microswitch and bracket and the insulated terminal (without wire lead) is replaced on NC terminal of microswitch.

5. Adjust microswitch operation as described in ADJUSTMENT.

SERVICE

OPERATIONAL DIFFICULTIES & PROBABLE CAUSES

OVEN PILOT BURNER GOES OUT:

1. Gas Shut Off.
2. Poor draft in flue snuffs out flame.
3. Too much draft pulls flame away from thermocouple.
4. Pilot flame too low.
5. Thermocouple defective.
6. Thermocouple connection on safety pilot valve loose.
7. Pilot orifice dirty.
8. Safety pilot valve defective.
9. Gas leak at pilot orifice fitting.
10. Restricted or plugged vent on gas pressure regulator.
11. Incorrect gas pressure setting on pressure regulator.
12. Make up air in kitchen blowing at flue outlet.

OVEN BURNER FAILS TO COME ON (PILOT ON):

1. Burner valve off.
2. Burner orifice plugged.
3. Thermostat out of calibration.
4. Minimum flame adjustment closed and thermostat setting too low.

OVEN TEMPERATURE HIGHER THAN DIAL SETTING:

1. Oven thermostat out of calibration.
2. Minimum flame too high (Do not lower under 1/8").
3. Broken capillary tube on thermostat.
4. Dirt under thermostat valve seat.

**Orifice Size Chart
Drill Size**

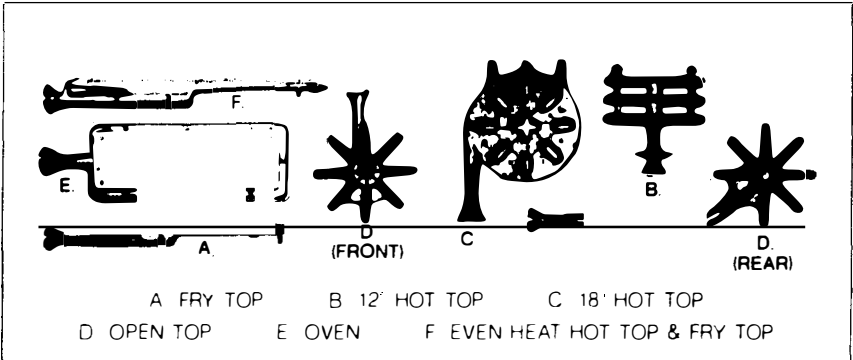

| Type of Burner | A | B | C | D | | E | | F |
|----------------------|----|----|----|--------------------------|------------------------------|-----|------|----|
| | | | | Open Top Front & Rear | 1/2 Hot Top Front Rear | 136 | V136 | |
| Natural Gas 4.0" WC | 50 | 46 | 35 | 45 | 45 50 | 32 | 31 | 45 |
| Propane Gas 10.0" WC | 56 | 55 | 50 | 55 | 55 56 | 49 | 47 | 55 |

VI36: VR26
 WIRING DIAGRAM
 120V; 1PH; 60 Hz

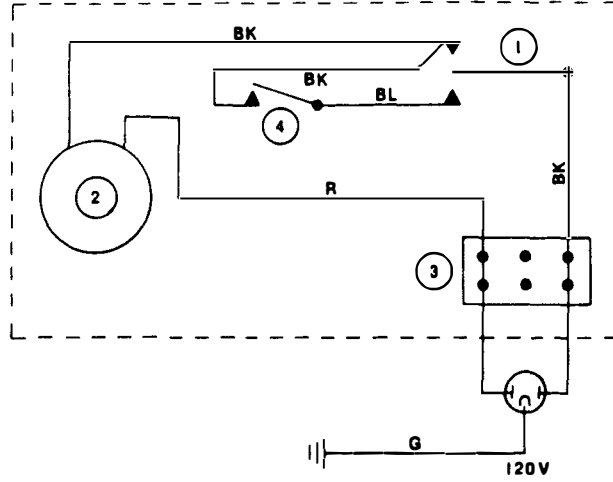

| ITEM | DESCRIPTION |
|------|-------------------------------|
| 1 | SWITCH, FAN |
| 2 | MOTOR (SPECIFY VOLTAGE & H P) |
| 3 | TERMINAL BLOCK |
| 4 | SWITCH, DOOR |

If any of the original wire, as supplied with the appliance, must be replaced, it must be replaced with the same type or its equivalent.

V136 SERIES MONTAGUE
CONVECTION OVEN TYPE
HEAVY DUTY GAS RANGE

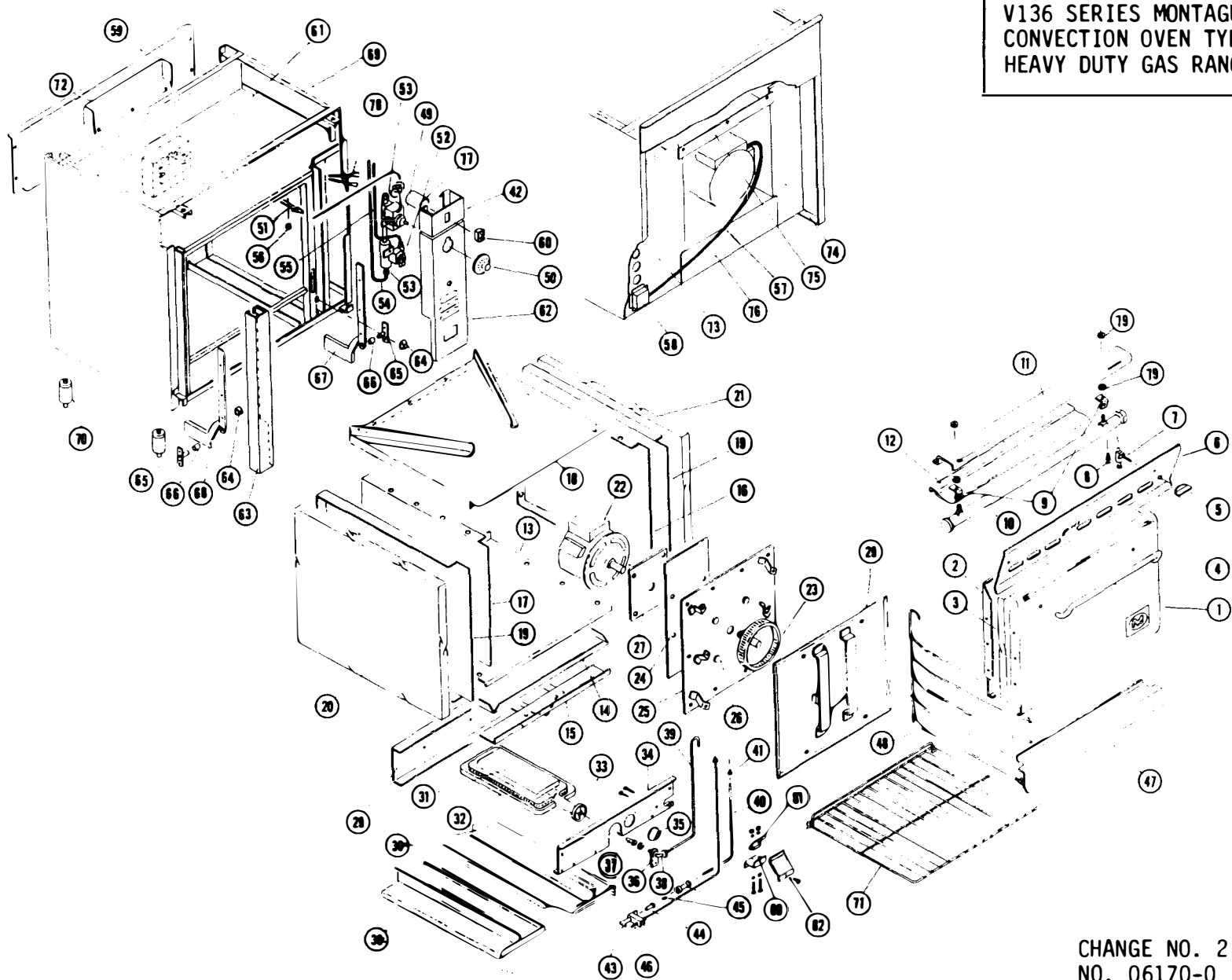

CHANGE NO. 2
NO. 06170-0 10 86

V136 SERIES MONTAGUE
CONVECTION OVEN TYPE
HEAVY DUTY GAS RANGE

| ITEM | PART NO. | DESCRIPTION | ITEM | PART | DESCRIPTION |
|------|----------|---|------|---------|---|
| 1 | 06134-4 | Panel, Door - PTD | 40 | 03604-8 | Tubing - Alum. w/sleeve; 1/4" OD X 30" |
| | 06135-2 | Panel, Door - S/S | 41 | 01277-7 | Nut, Threaded Sleeve- 1/4 tubing |
| 2 | 02428-7 | Liner - Door, Oven Interior | 42 | 08954-0 | Panel, Front - RT/Upper - Ptd |
| 3 | 01424-9 | Insulation, Door | | 08952-4 | Panel, Front - RT/Upper - S/S |
| 4 | 03173-9 | Handle | 43 | 01017-0 | Burner, Pilot Assembly - Natural |
| 5 | 02004-4 | Handle, Valve | | 01018-9 | Burner, Pilot Assembly - L.P. |
| 6 | 03566-1 | Panel, Control | 44 | 02190-3 | Orifice Hood - Natural |
| 7 | 01056-1 | Valve, Oven | | 02191-1 | Orifice Hood - L.P. |
| 8 | 01288-2 | Connector - Male, 1/8 NPTM X 1/4 CC | 45 | 06155-7 | Nut & Ferrule - 1.4 Tubing |
| 9 | 06137-9 | Bracket | 46 | 01013-8 | Thermocouple |
| 10 | 01073-1 | Manifold - 36" | 47 | 03459-2 | Panel, Burner Access - Ptd |
| 11 | 06860-8 | Rail, Front Guard - 36" | | 03524-6 | Panel, Burner Access - S/S |
| 12 | 04285-4 | Shield, - Drip, Manifold | 48 | 02365-5 | Guide - RT/LT, Rack |
| 13 | 02426-0 | Liner - Bottom, Oven Interior | 49 | 01061-8 | Thermostat w/Dial - FDTO |
| 14 | 06138-7 | Baffle - Heat Assembly | 50 | 01977-1 | Dial, Thermostat - FDTO |
| 15 | 06139-5 | Baffle - Flame | 51 | 06156-5 | Holder - Sensing Bulb |
| 16 | 02430-9 | Liner - Side Right, Oven Interior | 52 | 01062-6 | Valve, Safety |
| 17 | 02433-3 | Liner - Side Left, Oven Interior | 53 | 01287-4 | Connector - Male 3/8 NPTM X 7/16 CC |
| 18 | 02429-5 | Liner - Top, Oven Interior | 54 | 03600-5 | Tubing - Alum. w/Sleeve; 7/16" OD X 23" |
| 19 | 06140-9 | Liner, Insulation - Left & Right Assembly | 55 | 03605-6 | Tubing - Alum. w/Sleeve; 1/4" OD X 1 4" |
| 20 | 06141-7 | Insulation, Side - Left | 56 | 01942-9 | Clip |
| 21 | 06142-5 | Insulation, Side - Right | 57 | 06157-3 | Conduit - Flex |
| 22 | 06265-0 | Motor (Howell) 1/4 HP; 115V Only, 1 PH, 60 HZ. | 58 | 06158-1 | Junction Box Assembly |
| | 01402-8 | Motor (Baldor) 3/4 HP; 115/230V; 1 PH; 60 HZ. | 59 | 06160-3 | Panel, Back Assembly |
| | 02167-9 | Motor (Howell) 3/4 HP; 115/230V; 1 PH; 60 HZ. | 60 | 01305-6 | Switch, Rocker "FAN-OFF-COOL" |
| 23 | 02123-7 | Blower Wheel | 61 | 8584-7 | Block, Terminal |
| 24 | 6334-7 | Insulation-(used w/6265-0 & 2167-9) | 62 | 08935-4 | Panel, Front - RT/Lower-Ptd |
| | 6339-8 | Insulation-(used w/1402-8) | | 08940-0 | Panel, Front - RT/Lower-S/S |
| 25 | 06337-1 | Plate Assembly, Motor Mtg-Rear (used w/06265-0) | 63 | 04288-9 | Panel, Front - Left; Ptd |
| | 06076-3 | Plate Assembly, Motor Mtg-Rear (used w/01402-8 & 02167-9) | | 04286-2 | Panel, Front - Left; S/S |
| 26 | 01945-3 | Screw, Weld 5/16 - 18 X 1-1/2 | 64 | 06926-4 | Catch, Spring (Female) |
| 27 | 06333-9 | Plate, Motor - Spacer (used w/06265-0) | 65 | 03393-6 | Pin Assembly, Door |
| | 04385-0 | Plate, Motor - Spacer (used w/01402-8 & 02167-9) | 66 | 01260-2 | Spacer |
| 28 | 02431-7 | Baffle- Rear, Fan | 67 | 06885-3 | Trunnion Assembly - Right w/Bracket |
| 29 | 06144-1 | Support - Channel | 68 | 06079-8 | Trunnion Assembly - Left |
| 30L | 06346-0 | Baffle - Air, Lt | 69 | 06161-1 | Body, Range - Painted |
| 30R | 06348-7 | Baffle - Air, Rt | 70 | 03468-1 | Leg w/Foot - Painted - 6 in. |
| 31 | 03344-8 | Baffle - Air | | 03467-3 | Leg w/Foot - S/S - 6 in. |
| 32 | 06349-5 | Burner Assembly (Complete) - Nat. Gas | 71 | 02364-7 | Rack, Wire |
| | 06350-9 | Burner Assembly (Complete) - LP Gas | 72 | 06163-8 | Deflector, Flue |
| 33 | 02037-0 | Air Mixer | 73 | 06164-6 | Panel, Rear - Right Assembly |
| 34 | 06147-6 | Front, Burner Compartment | 74 | 06165-4 | Panel, Rear - Left |
| 35 | 06148-4 | Door, Pilot Access | 75 | 06166-2 | Panel, Rear - Top Center |
| 36 | 06149-2 | Bracket - Orifice Fitting | 76 | 06167-0 | Panel, Rear - Lower Center |
| 37 | 06150-6 | Orifice Hood - Natural (4.0" W.C.) | 77 | 06168-9 | Tubing, Heat Shrink |
| | 06151-4 | Orifice Hood - LP. (10.0" W.C.) | 78 | 06169-7 | Wire Assembly |
| 38 | 06152-2 | Orifice, Elbow Assembly - Natural (4.0" W.C.) | 79 | 01912-7 | Nut, Hex - Pin |
| | 06153-0 | Orifice, Elbow Assembly - LP (10.0" W.C.) | 80 | 06950-7 | Bracket, Door Switch |
| 39 | 03602-1 | Tubing - Alum. w/sleeve; 7/16" OD X 42" | 81 | 06266-9 | Switch, Door |
| | | | 82 | 06952-3 | Cover, Door Switch |

MONTAGUE HEAVY DUTY GAS RANGE
 OPEN TOP SECTION - 12" AND 18" WIDE
 1/2 OPEN TOP 1/2 HOT TOP - 12" WIDE

PLEASE ORDER BY PART NO. AND DESCRIPTION

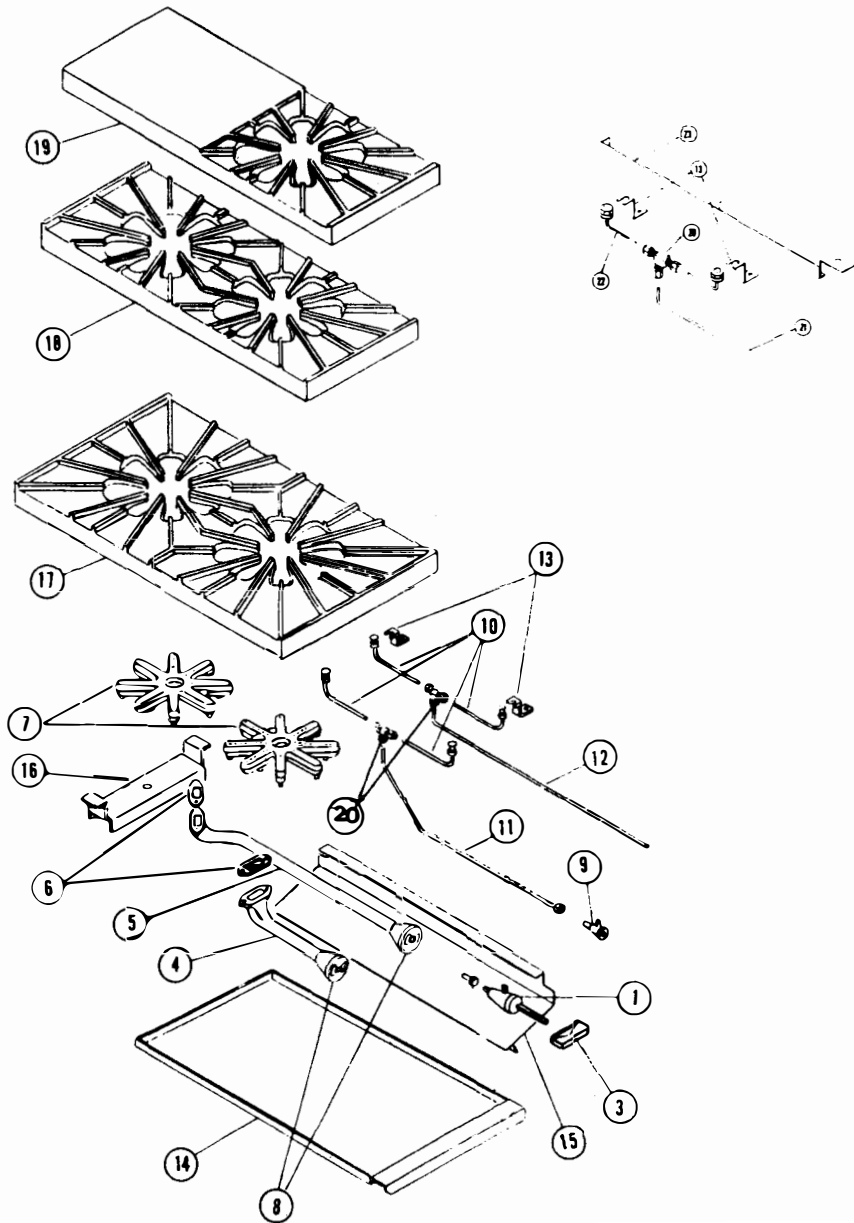

| ITEM | PART NO. | DESCRIPTION |
|-------------|----------|--|
| 1 | 04330-3 | Valve, Top Burner (Nat) ⚠ Except 1/2 Hot Top |
| 1 | 01003-0 | Valve, Top Burner (LP) ⚠ Except 1/2 Hot Top |
| 1 | 02405-8 | Valve, Top Burner (Nat) ⚠ 1/2 Hot Top Only |
| 1 | 01002-2 | Valve, Top Burner (LP) ⚠ 1/2 Hot Top Only |
| 3 | 02002-8 | Handle, Valve w/Set Screw |
| 4 | 03348-0 | Venturi, Front Burner |
| 4, 6, 7, 8 | 03347-2 | Burner, Front - Complete |
| 5 | 03350-2 | Venturi, Rear Burner (Left swing shown) ⚠ |
| 5, 6, 7, 8 | 03349-9 | Burner, Rear Left - Complete |
| 5A, 6, 7, 8 | 03351-0 | Burner, Rear Right - Complete (not shown) |
| 6 | 02115-6 | Gasket |
| 7 | 03346-4 | Burner Head Only |
| 8 | 02038-9 | Air Mixer |
| 9 | 01055-3 | Pilot Valve |
| 10 | 03583-1 | Lighter, Pilot |
| 10, 11, 20 | 03431-2 | Pilot Kit - 12" Section (Less Valve) |
| 10, 12, 20 | 03430-4 | Pilot Kit - 18" Section (Less Valve) |
| 20, 21, 22 | 07142-0 | Pilot Kit - 12" -59 Section (Less Valve) |
| 13 | 01518-0 | Pilot Bracket |
| 14 | 03379-0 | Drip Tray - 36" Unit ⚠ |
| 14 | 03378-2 | Drip Tray - 24" Unit ⚠ |
| 14 | 03377-4 | Drip Tray - 18" & 12" Unit ⚠ |
| 15 | 03380-4 | Drip Tray Guide |
| 16 | 03498-3 | Support, Open Burner 36" Unit ⚠ |
| 16 | 03530-0 | Support, Open Burner 24" Unit ⚠ |
| 16 | 03531-9 | Support, Open Burner 18" Unit ⚠ |
| 16 | 03532-7 | Support, Open Burner 12" Unit ⚠ |
| 17 | 03480-0 | 18" Open Top |
| 18 | 03580-7 | 12" Open Top |
| 19 | 03482-7 | 12" Combination -59 Top (1/2 Hot Top) |
| 22 | 06232-4 | Lighter, Pilot |
| 23 | 03556-4 | Bracket, Pilot MTG (-59 Top) |

⚠ Specify Type of Gas & Manifold Pressure

⚠ Specify Left or Right Swing

⚠ Specify Width

No. 105B-1/1186

MONTAGUE HEAVY DUTY GAS RANGE
FRY TOP SECTION THERMOSTAT CONTROLLED OR 42" DEEP RANGE

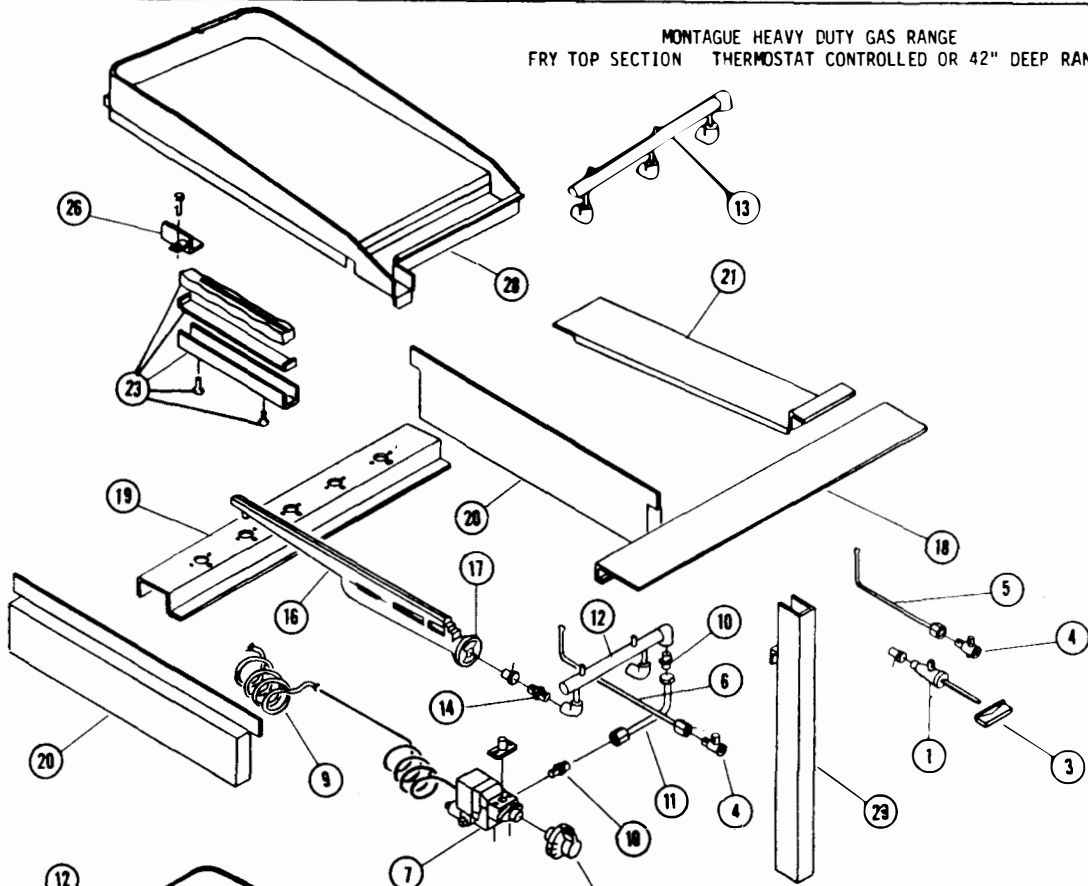

PLEASE ORDER BY PART NO. AND DESCRIPTION

| ITEM | PART NO. | DESCRIPTION |
|------|----------|--|
| 1 | 04330-3 | Valve, Top Burner - Nat |
| 1 | 01003-0 | Valve, Top Burner - LP |
| 3 | 02002-8 | Handle, Valve w/set screw |
| 4 | 01055-3 | Valve, Pilot |
| 5 | 03416-9 | Pilot Lighter (without thermostat) |
| 6 | 03418-5 | Pilot Lighter (with thermostat) |
| 7 | 03367-7 | Thermostat, Griddle - BJWA w/Dial |
| 8 | 01022-7 | Dial, Thermostat |
| 9 | 07125-0 | Insulation Sleeve for Capillary |
| 10 | 01271-8 | Fitting 1/4" NPT x 7/16" Tubing |
| 11 | ----- | Aluminum Tubing 7/16" CC |
| 12 | 01103-7 | Manifold - 2 Burner |
| 13 | 01104-5 | Manifold - 3 Burner |
| 14 | 02407-4 | Fitting-Hex w/Orifice - Nat |
| 14 | 01059-6 | Fitting Hex w/Orifice - LP |
| 16 | 03362-6 | Burner, Complete |
| 17 | 02037-0 | Air Mixer, Burner |
| 18 | 10913-4 | Support-Front,Air Baffle - 36" |
| 18 | 09302-5 | Support-Front,Air Baffle - 24" |
| 18 | 09303-3 | Support-Front,Air Baffle - 18" |
| 18 | 09304-1 | Support-Front,Air Baffle - 12" |
| 19 | 07127-7 | Support, Burner - 36" |
| 19 | 07130-7 | Support, Burner - 24" |
| 19 | 07128-5 | Support, Burner - 18" |
| 19 | 07129-3 | Support, Burner - 12" |
| 20 | 03560-2 | Baffle - Heat Assy. |
| 21 | 03533-5 | Baffle - Air Assy. 3-1/8" Small |
| 21 | 03540-8 | Baffle - Air Assy. 5-1/8" Medium |
| 23 | 03386-3 | Thermal Bulb Holder - Complete |
| 26 | 06004-6 | Adjusting Bracket w/Bolt,Left |
| 26 | 06005-4 | Adjusting Bracket w/Bolt,Right (Not shown) |
| 28 | ----- | Fry Top |
| 29 | 03368-5 | Container, Grease - Painted |
| 29 | 02150-4 | Container, Grease - Chromed |

- Specify Finish
- Specify Gas & Manifold Pressure
- Specify Width & Thickness
- Specify Width

MONTAGUE HEAVY DUTY GAS RANGE
FRY TOP SECTION - MANUAL CONTROLLED 36" DEEP RANGE

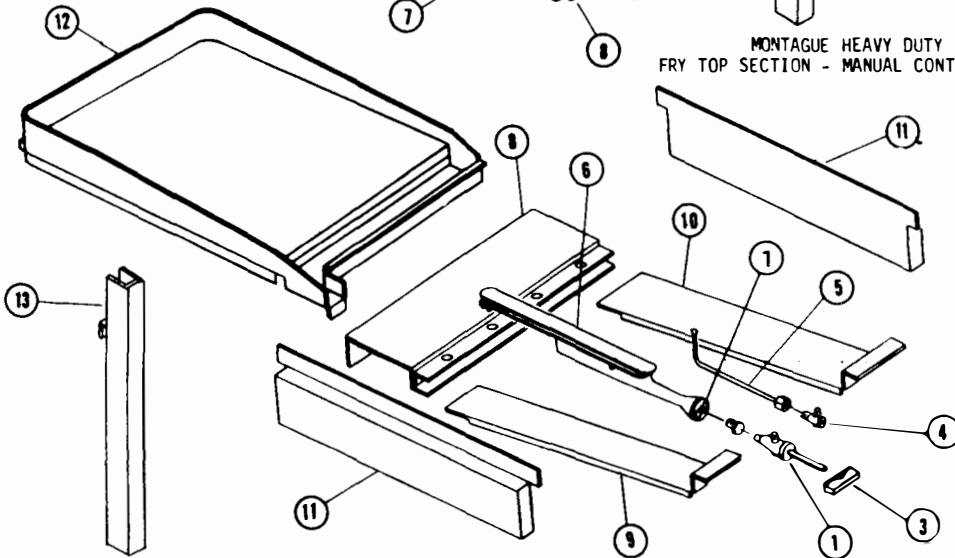

PLEASE ORDER BY PART NO. AND DESCRIPTION

| ITEM | PART # | DESCRIPTION |
|------|---------|----------------------------------|
| 1 | 02405-B | Valve, Top Burner - Nat |
| 1 | 01002-2 | Valve, Top Burner - LP |
| 3 | 02002-8 | Handle, Valve w/Set Screw |
| 4 | 01055-3 | Valve, Pilot |
| 5 | 03416-9 | Pilot Lighter |
| 6 | 03361-8 | Burner-Complete |
| 7 | 02038-9 | Air Mixer |
| 8 | 03559-9 | Support, Burner - 36" Unit |
| 8 | 03541-6 | Support, Burner - 24" Unit |
| 8 | 07126-9 | Support, Burner - 18" Unit |
| 8 | 03096-1 | Support, Burner - 12" Unit |
| 9 | 03533-5 | Baffle - Air Assy. 3-1/8" Small |
| 10 | 03540-8 | Baffle - Air Assy. 5-1/8" Medium |
| 11 | 03560-2 | Baffle - Heat Assy. |
| 12 | ----- | Frytop |
| 13 | 03368-5 | Container, Grease - Painted |
| 13A | 02150-4 | Container, Grease - Chromed |

- Specify Finish
- Specify Gas and Manifold Pressure
- Specify Width and Thickness
- Specify Width

MONTAGUE HEAVY DUTY GAS RANGE
HOT TOP SECTION 18" WIDE FRONT FIRED

PLEASE ORDER BY PART NO. AND DESCRIPTION

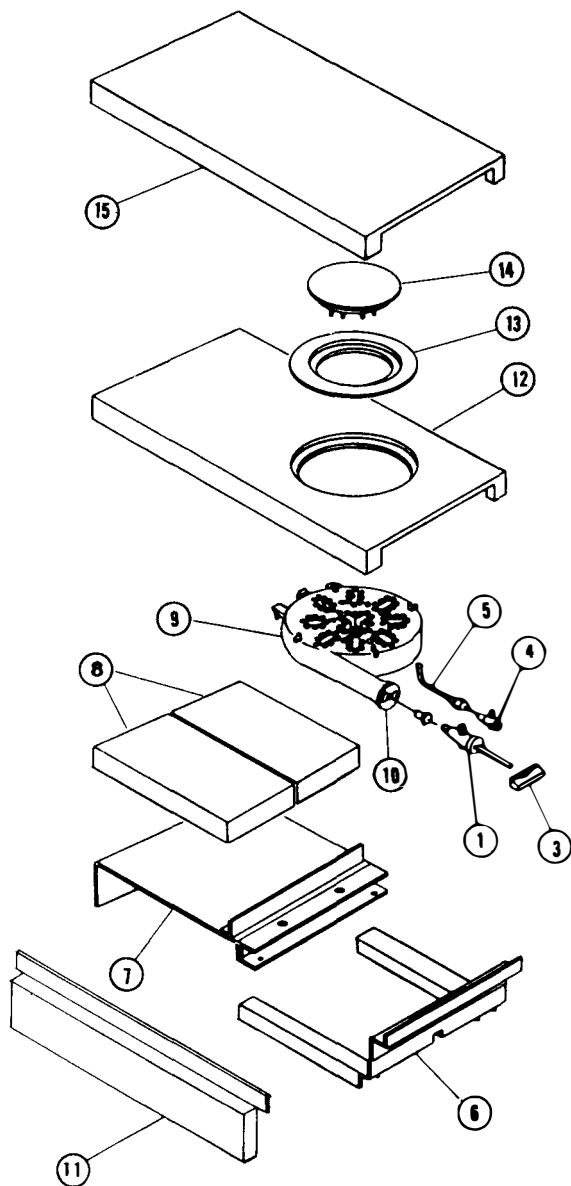

| ITEM | PART NO. | DESCRIPTION |
|------|----------|---|
| 1 | 02408-2 | Valve, Top Burner - Nat. |
| 1 | 02405-8 | Valve, Top Burner - LP |
| 3 | 02002-8 | Handle, Valve w/Set Screw |
| 4 | 01055-3 | Valve, Pilot |
| 5 | 03419-3 | Pilot Lighter |
| 6 | 04412-1 | Baffle-Air Assy - 36" Unit ⚠ |
| 6 | 04414-8 | Baffle-Air Assy - 18" Unit ⚠ |
| 7 | 04281-1 | Burner & Brick Support - 36" Unit |
| 7 | 04298-6 | Burner & Brick Support - 18" Unit |
| 8 | 01764-7 | Brick (1-1/4 x 8 x 13) |
| 9 | 03356-1 | Burner, 18" Hot Top - Complete (Right Swing) ⚠ |
| 9A | 03355-3 | Burner, 18" Hot Top - Complete (Left Swing) Not Shown ⚠ |
| 10 | 02037-0 | Air Mixer |
| 11 | 03560-2 | Insulated Side Shield |
| 12 | 01743-4 | Hot Top - 18" W/Ring & Cover |
| 13 | 01745-0 | Ring |
| 14 | 01747-7 | Cover |
| 15 | 01741-8 | Hot Top - 18" - Solid |

- ⚠ Specify Gas & Manifold Pressure
- ⚠ Specify Swing
- ⚠ Specify Width

No. 105C-1 1186

MONTAGUE HEAVY DUTY GAS RANGE
HOT TOP SECTION 12" WIDE FRONT FIRED

PLEASE ORDER BY PART NO. AND DESCRIPTION

| ITEM | PART # | DESCRIPTION |
|------|---------|---|
| 1 | 02406-6 | Valve, Top Burner - Nat $\triangle 3$ |
| 1 | 01003-0 | Valve, Top Burner - LP $\triangle 3$ |
| 3 | 02002-8 | Handle, Valve W/Set Screws |
| 4 | 01055-3 | Valve, Pilot |
| 5 | 03421-5 | Pilot Lighter |
| 6 | 04299-4 | Burner Support W/Insulation - 36" $\triangle 6$ |
| 6 | 04284-6 | Burner Support W/Insulation - 24" $\triangle 6$ |
| 6 | 04283-8 | Burner Support W/Insulation - 12" $\triangle 6$ |
| 7 | ----- | Insulation Pad $\triangle 6$ |
| 9 | 03353-7 | Burner, 12" Hot Top |
| 10 | 02038-9 | Air Mixer |
| 11 | 01635-7 | Baffle, Burners - Cast Iron |
| 12 | ----- | Manifold Shield W/Stops $\triangle 6$ |
| 13 | 03560-2 | Insulated Side Shield |
| 14 | 01738-8 | Hot Top - 12" Section |

- $\triangle 3$ Specify Gas & Manifold Pressure
 $\triangle 6$ Specify Width

MONTAGUE HEAVY DUTY GAS RANGE
HOT TOP SECTION - EVEN HEAT 12" AND 18" WIDE

PLEASE ORDER BY PART NO. AND DESCRIPTION

| ITEM | PART NO. | DESCRIPTION |
|------|----------|---|
| 1 | 04330-3 | Valve, Top Burner - Nat $\triangle 3$ |
| 1 | 01003-0 | Valve, Top Burner - LP $\triangle 3$ |
| 3 | 02002-8 | Handle, Valve w/Set Screw $\triangle 3$ |
| 4 | 01055-3 | Valve, Pilot |
| 5 | 03416-9 | Pilot Lighter |
| 6 | 03362-6 | Burner, Even Heat Hot Top - Complete |
| 7 | 02037-0 | Air Mixer |
| 8 | 10628-3 | Support, Burner - 36" |
| 8 | 04468-7 | Support, Burner - 24" |
| 8 | 10629-1 | Support, Burner - 18" |
| 8 | 07133-1 | Support, Burner - 12" |
| 9 | 03560-2 | Baffle - Heat assy. $\triangle 6$ |
| 10 | 03533-5 | Baffle - Air Assy. 3-1/8"wide $\triangle 6$ |
| 10 | 03538-6 | Baffle - Air Assy. 9-1/4"wide $\triangle 6$ |
| 11 | 01738-8 | Hot Top, 12" Section |
| 12 | 01741-8 | Hot Top, 18" Section |

- $\triangle 3$ Specify Gas & Manifold Pressure
 $\triangle 6$ Specify Width

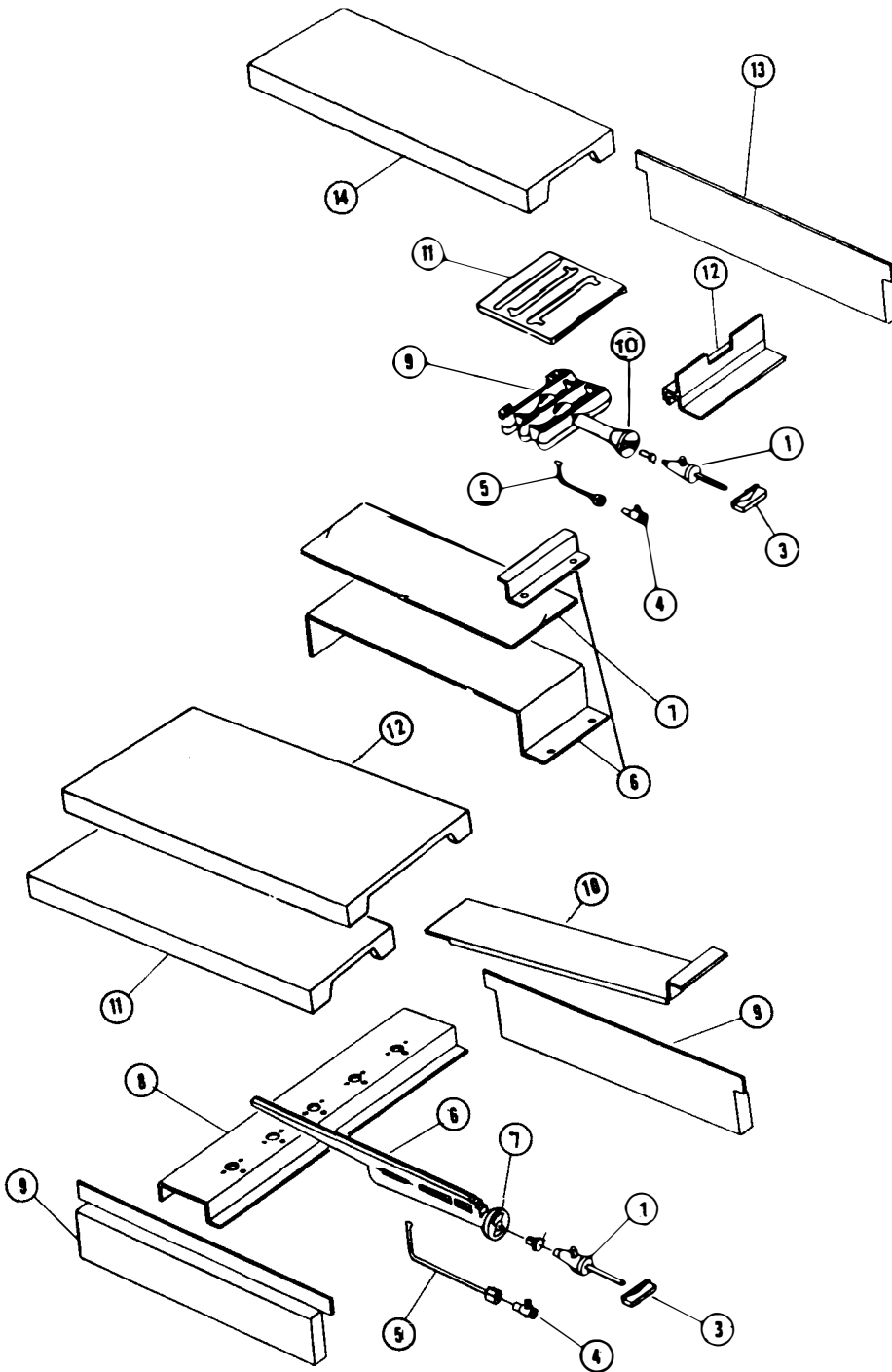

WARNING

If not installed, operated and maintained in accordance with the manufacturer's instructions, this product could expose you to substances in fuel or in fuel combustion which can cause death or serious illness and which are known to the State of California to cause cancer, birth defects or other reproductive harm.

The State of California enacted the California Safe Drinking Water and Toxic Enforcement Act of 1986, (Prop. 65), which "prohibits any person in the course of doing business from knowingly and intentionally exposing any individual to a chemical known to the State of California to cause cancer or reproductive toxicity without first giving clear and reasonable warning to such individuals." The Governor's Scientific Advisory Panel added carbon monoxide to the list of hazardous chemicals known to cause reproductive harm.

In order to establish full compliance with Proposition 65, we attached a yellow warning label to each gas fired unit manufactured by the Montague Company.

Carbon monoxide would not be present in concentrations that would pose a "significant risk" to the consumer when the equipment is installed, operated and maintained as follows:

1. Installed in accordance with all local codes, or in the absence of local codes, with the current National Fuel Gas Code Z223.1.
2. Installed under a properly designed and operating exhaust hood.
3. Connected to the type of gas for which the unit is equipped.
4. Proper appliance pressure regulator installed on the gas supply line and adjusted for the manifold pressure marked on the rating plate.
5. Adequate air supply to the unit.
6. The equipment is operated in the manner intended using the proper utensil for that type of appliance.
7. Keep the equipment clean and have it checked periodically.
8. Burner air adjustments, mechanical maintenance and repairs should be performed by qualified service personnel.

If the equipment is not installed, operated and maintained in accordance with the above, concentrations of carbon monoxide in excess of the established limits could be present in the kitchen environment.

ALL PERSONNEL IN THE WORKPLACE WHO MAY BE SUBJECT TO ANY EXPOSURE OF CARBON MONOXIDE MUST BE WARNED OF SUCH POSSIBLE EXPOSURE. THIS WARNING SHOULD BE CONVEYED IN A MANNER SO THAT IT IS CLEARLY UNDERSTOOD BY THE EMPLOYEE, AND THE EMPLOYEE SHOULD BE ASKED IF IN FACT HE OR SHE UNDERSTANDS THE CORRECT METHOD OF OPERATION OF THE EQUIPMENT AND THAT A RISK OF EXPOSURE EXISTS IF THE EQUIPMENT IS OPERATED IMPROPERLY.

IMPORTANT

When ordering parts, to eliminate mistakes and facilitate delivery, always give the following information:

Serial No. _____

Model No. _____

Change No. _____

Name & No. of Part

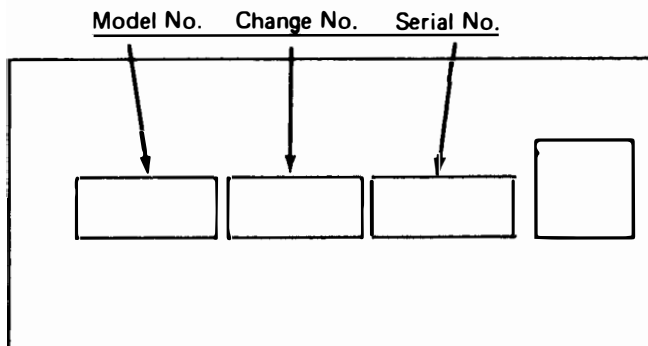

136 SERIES RATING PLATE

The Montague Company
1830 Stearman Avenue
P.O. Box 4954
Hayward, Ca. 94540-4954