

INSTRUCTION MANUAL

MONTAGUE **LEGEND**

Heavy Duty
Gas Fired Fryers

Models:
RF40, RF240, RD18

**These instructions should be read thoroughly before attempting installation.
Set up and installation should be performed by qualified installation personnel.**

Keep area around appliances free and clear from combustibles.

**PLEASE RETAIN THIS MANUAL
FOR FUTURE REFERENCE.**



THE MONTAGUE COMPANY

1830 STEARMAN AVENUE, P.O. BOX 4954

HAYWARD, CA 94540-4954

TEL: 510/785-8822 FAX: 510/785-3342

CONTENTS

INSTALLATION 1
OPERATION14

MAINTENANCE16
SERVICE 23

IMPORTANT

WARNING:

Improper installation, adjustment, alteration, service or maintenance can cause property damage, injury or death. Read the operating and maintenance instructions thoroughly before installing or servicing this equipment.

FOR YOUR SAFETY:

Do not store or use gasoline or other flammable vapors and liquids in the vicinity of this or any other appliance.

INSTRUCTIONS TO BE FOLLOWED IN THE EVENT THE USER SMELLS GAS MUST BE POSTED IN A PROMINENT LOCATION. THIS INFORMATION MAY BE OBTAINED BY CONSULTING THE LOCAL GAS SUPPLIER.

SHIPPING DAMAGE CLAIM PROCEDURE

For your protection, please note that equipment in this shipment was carefully inspected and packed by skilled personnel before leaving the factory. The transportation company assumed full responsibility for safe delivery upon acceptance of this shipment.

If shipment arrives damaged:

1. **VISIBLE LOSS OR DAMAGE** - Be certain this is noted on freight bill or express receipt, and signed by person making delivery.
2. **FILE CLAIM FOR DAMAGES IMMEDIATELY** - Regardless of the extent of damage.
3. **CONCEALED LOSS OR DAMAGE** - If damage is unnoticed until merchandise is unpacked, notify transportation company or carrier immediately, and file "concealed damage" claim with them. This should be done within fifteen (15) days of date that delivery was made to you. Be sure to retain container for inspection.

We cannot assume responsibility for damage incurred in transit. We will, however, be glad to furnish you with necessary documents to support your claim.

INSTALLATION

NOTICE

This appliance is intended for professional use only and is to be operated by qualified personnel only. A Montague Company Authorized Service Agency or other qualified professional should perform installation, maintenance, and repairs. Installation, maintenance, or repairs by unqualified personnel may void the manufacturer's warranty. See the section on Installation in this manual for definitions of qualified personnel.

NOTICE

This equipment must be installed in accordance with the appropriate national and local codes of the country and/or region in which the appliance is installed. See **NATIONAL CODE REQUIREMENTS** in the Operation Section of this manual for specifics.

NOTICE TO U.S. CUSTOMERS

This equipment is to be installed in compliance with the basic plumbing code of the Building Officials and Code Administrators International, Inc. (BOCA) and the Food Service Sanitation Manual of the U.S. Food and Drug Administration.

NOTICE

Drawings and photos used in this manual are intended to illustrate operational, cleaning and technical procedures and may not conform to onsite management operational procedures.

DANGER

Improper installation, adjustment, maintenance or service, and unauthorized alterations or modifications can cause property damage, injury, or death. Read the installation manual and all markings thoroughly before installing or servicing this equipment. Only qualified service personnel may convert this appliance to use a gas other than that for which it was originally configured.

DANGER

No structural material on the fryer should be altered or removed to accommodate placement of the fryer under a hood. Questions? Call The Montague Co. Service Hotline at 1-888-875-2722.

DANGER

The front ledge of the fryer is not a step! Do not stand on the fryer. Serious injury can result from slips or contact with the hot oil.

DANGER

Do not store or use gasoline or other flammable liquids or vapors in the vicinity of this or any other appliance.

DANGER

Instructions to be followed in the event the operator smells gas or otherwise detects a gas leak must be posted in a prominent location. This information can be obtained from the local gas company or gas supplier.

INSTALLATION

General Installation Requirements

PROPER INSTALLATION IS ESSENTIAL FOR EFFICIENT, TROUBLE-FREE OPERATION OF YOUR FRYER. ANY UNAUTHORIZED ALTERATIONS MADE TO THIS EQUIPMENT WILL VOID THE MONTAGUE COMPANY WARRANTY.

Upon arrival, inspect the fryer carefully for visible or concealed damage.

CLEARANCE AND VENTILATION

The fryer(s) must be installed with a 6" (150 mm) clearance at both sides and back when installed adjacent to combustible construction; no clearance is required when installed adjacent to noncombustible construction. A minimum of 24" (600 mm) clearance should be provided at the front of the fryer.

One of the most important considerations of efficient fryer operation is ventilation. Make sure the fryer is installed to efficiently remove combustion by-products, and the kitchen ventilation system does not produce drafts that interfere with proper burner operation.

The fryer flue opening must not be placed close to the intake of the exhaust fan, and the fryer must never have its flue extended in a "chimney" fashion. An extended flue will change the combustion characteristics of the fryer, causing longer recovery time. It also frequently causes delayed ignition. To provide the airflow necessary for good combustion and burner operation, the areas surrounding the fryer front, sides, and rear must be kept clear and unobstructed.

Fryers must be installed in an area with an adequate air supply and adequate ventilation. Adequate distances must be maintained from the flue outlet of the fryer to the lower edge of the ventilation filter bank. Filters should be installed at an angle of 45°. Place a drip tray beneath the lowest edge of the filter. For U.S. installation, NFPA standard No. 96 states, "A minimum distance of 18 in. (450 mm) should be maintained between the flue outlet and the lower edge of the grease filter." The Montague Co. *recommends that the minimum distance be 24 in. (600 mm) from the flue outlet to the bottom edge of the filter when the appliance consumes more than 120,000 BTUs per hour.* Information on construction and installation of ventilating hoods can be found in the NFPA standard cited above. A copy of the standard may be obtained from the National Fire Protection Association, Battery March Park, Quincy, MA 02269.

DANGER

Do not attach an apron drainboard to a single fryer. The fryer may become unstable, tip over, and cause injury. The appliance area must be kept free and clear of combustible material at all times.

INSTALLATION

ALL DEEP FAT FRYERS MUST BE INSTALLED WITH AT LEAST A 16 INCH SPACE BETWEEN THE FRYER AND SURFACE FLAMES FROM ANY ADJACENT COOKING EQUIPMENT.

A minimum of 24" should be provided at the front of the unit for servicing and proper operation. Air for combustion enters the unit from the front of the cabinet. Do not block these openings at any time.

THE APPLIANCE AREA MUST BE KEPT FREE AND CLEAR OF COMBUSTIBLES.

ASSEMBLY

Uncrate fryer as near to final location as possible. Remove all packing material and accessories from fryer interior. Then assemble as follows:

1. Screw the adjustable feet of the legs in all the way. Then tightly screw the complete leg assembly into the mounting holes at each corner of the fryer.
2. Attach basket hanger mount as shown in Figure 1 using bolts that are provided.

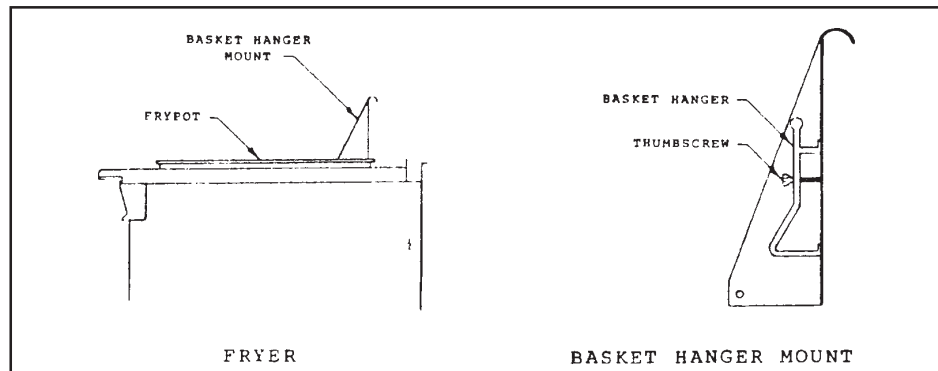

FIGURE 1

SETTING IN PLACE

Battery Arrangement

1. Place the first unit in the exact position it will occupy in the battery.
2. Using a carpenter's level, level the unit from front to rear and side to side. Adjust as follows:

FLOOR INSTALLATION ON LEGS: Adjust by turning foot on adjustable leg.

INSTALLATION

CURB INSTALLATION: Place shim under the low side. This operation is important since variation in floor and curbs are common. Unless ranges are level, difficulty will be encountered in aligning the gas supply manifold and the ranges will not butt together tightly.

3. Remove the upper valve panel from the fryer.
4. Move the next unit into position.
5. Engage union nut on manifold with male fitting on next unit and draw up union nut hand tight. Be sure appliances butt together both front and rear. If manifolds do not align, then units are not level. In extreme cases, it may be necessary to loosen manifold bolts and adjust.
6. Continue leveling and connecting gas supply manifolds together until all appliances in battery are connected.
7. Tighten manifold union gas tight. Use back up wrench to prevent manifold from rotating. **FAILURE TO DO THIS MAY RESULT IN DAMAGE TO PILOTS AND GAS VALVES.**
8. Lift the flue riser above the fryer and slide posts into position as shown in Figure 2.

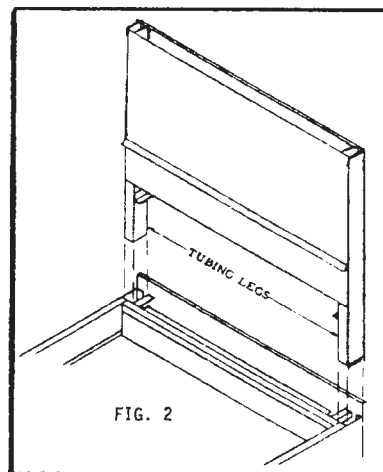

GAS APPLIANCE REGULATOR

Each deep fat fryer unit is equipped with a gas pressure regulator as a part of the combination gas control. It is adjusted for the manifold pressure specified on the fryer nameplate.

WHEN THE FRYER UNIT MANIFOLD IS INTERCONNECTED AS PART OF A BATTERY, A GAS APPLIANCE PRESSURE REGULATOR SUITABLE FOR THE BATTERY APPLICATION AND ADJUSTED FOR THE MANIFOLD PRESSURE SPECIFIED ON THE RANGE. NAMEPLATE MUST BE FURNISHED BY THE INSTALLER AT THE TIME OF INSTALLATION.

INSTALLATION

1. Adequate means must be provided to limit the movement of fryers without depending upon the gas line connections. If a flexible gas hose is used, a restraining cable must be connected at all times when the fryer is in use. The restraining cable and installation instructions are packed with the flexible hose in the accessories box that was shipped with your unit.

2. Single unit fryers must be stabilized by installing restraining chains on fryers equipped with casters or anchor straps on fryers equipped with legs. Follow the instructions shipped with the casters/legs to properly install the chains or straps.

3. Level fryers equipped with legs by extending the adjustable portion of the leg out approximately 1 inch, and then further adjust the legs, ensuring the fryer is level and at the proper height in the exhaust hood. Montague recommends that the minimum distance from the flue outlet to the bottom edge of the filter be 24 in. (600 mm) when the appliance consumes more than 120,000 BTU per hour.

Refer to the data plate on the inside of the fryer door to determine if the fryer burner is configured for the proper type of gas before connecting the fryer quick-disconnect device or piping from the gas supply line.

Verify that the minimum and maximum gas supply pressures for the type of gas to be used are in accordance with the following tables.

Incoming Gas Pressure		
Gas	Minimum	Maximum
Natural	6" WC 1.49 kPa 14.93 mbar	14" WC 3.48 kPa 34.84 mbar
LP	11" WC 2.74 kPa 27.37 mbar	14" WC 3.48 kPa 34.84 mbar

INSTALLATION

Connection to Gas Line

The size of the gas line used for installation is very important. If the line is too small, the gas pressure at the burner manifold will be low. This may cause pilot outage, slow recovery and delayed ignition. The incoming gas supply line should be a minimum of 1½" (38 mm) in diameter. Refer to the chart below for the minimum sizes of connection piping.

Gas Connection Pipe Sizes (Minimum incoming pipe size should be 1-1/2" (38 mm))			
Gas	Single Unit	2-3 Units	4 or more Units*
Natural	1/2" (13 mm)	1" (25 mm)	1-1/4" (33 mm)
Propane	1/2" (13 mm)	1" (25 mm)	1" (25 mm)
Manufactured	1" (25 mm)	1-1/4" (33 mm)	1-1/2" (38 mm)

NOTE: For distances of more than 20 feet (6 m) and/or more than 4 fittings or elbows, increase the connection by one pipe size.

INSTALLATION

Before connecting new pipe to your unit, the pipe must be thoroughly blown out to remove any foreign particles. If these foreign particles get into the burner and controls, they will cause improper and sometimes dangerous operation.

1. Connect the quick-disconnect hose to the fryer quick-disconnect fitting under the front of the fryer and to the building gas line.

NOTE: Some fryers are configured for a rigid connection to the gas supply line. These units are connected to the gas supply line at the rear of the unit.

When using thread compound, use very small amounts on male threads only. Use a pipe thread compound that is not affected by the chemical action of LP gases (Loctite™ PST56765 Sealant is one such compound). DO NOT apply compound to the first two threads. This will ensure that the burner orifices and control valve do not become clogged.

2. Open the gas supply to the fryer and check all piping, fittings, and gas connections for leaks. A soap and water solution should be used for this purpose.

DANGER

Never use matches, candles, or any other ignition source to check for leaks. If gas odors are detected, shut off the gas supply to the fryer at the main shut-off valve and contact the local gas company or an authorized service agency for service.

3. Close the fryer drain valve and fill the frypot with water or boil-out solution to the bottom OIL-LEVEL line at the rear of the frypot. Light the fryer and perform the boil-out procedures that are described in the “Lighting Instructions” and “Boiling Out the Frypot” topics found in the OPERATION section of this manual.

WARNING

“Dry-firing” your unit will cause damage to the frypot. Always ensure that melted shortening, cooking oil, or water and boil-out solution is in the frypot before firing your unit.

INSTALLATION

4. It is suggested that the burner manifold pressure be checked at this time by the local gas company or an authorized service agent. Refer to “Check Burner Manifold Pressure” in MAINTENANCE section of this manual for the proper procedure.

Burner Manifold Gas Pressure	
Gas	Pressure
Natural	4" WC 0.87 kPa
LP	9" WC 2.24 kPa

Converting to Another Gas Type

Your fryer is configured at the factory for either natural gas or Propane (LP) gas.

If you desire to switch from one type of gas to another, a gas conversion kit must be installed by a Montague Company Authorized Service technician.

DANGER

Switching to a different type of gas without installing the proper conversion kit may result in fire or explosion!

NEVER ATTACH YOUR FRYER TO A GAS SUPPLY FOR WHICH IT IS NOT CONFIGURED!

GAS CONNECTION

Before connecting the range and fryer battery to the gas supply line, be sure that all new piping has been cleaned and purged to prevent any foreign matter from being carried into the controls by the gas. In some cases, filters or drops are recommended. A separate Gas Shut Off Valve must be installed upstream from the range and fryer battery and located in an accessible area.

WARNING

CAP ALL UNUSED OPEN ENDS OF THE GAS SUPPLY MANIFOLD

It is important that adequately sized piping be run directly to the point of connection at range and fryer battery with as few elbows and tees as possible. Consult local gas company for proper piping size and gas pressure.

PIPE JOINT COMPOUND OR THREAD SEALANT THAT IS USED SHOULD BE RESISTANT TO ACTION OF LIQUEFIED PETROLEUM GASES. USE SPARINGLY AND ONLY ON MALE THREADS.

Turn Gas Shut Off Valve "ON" and immediately check carefully for gas leaks. Do this before attempting to operate the range and fryer battery.

TEST ALL PIPE JOINTS FOR LEAKS BEFORE OPERATING BROILER(S) OR ANY OTHER APPLIANCE. THIS INCLUDES ALL GAS CONNECTIONS THAT MAY HAVE LOOSENED DURING SHIPMENT. USE A RICH SOAP SOLUTION (OR OTHER ACCEPTED LEAK TESTER) AROUND ALL PIPE CONNECTIONS AND ALL OTHER JOINTS. DO NOT USE AN OPEN FLAME. ABSOLUTELY NO LEAKAGE SHOULD OCCUR, OTHERWISE, THERE IS A DANGER OF FIRE OR EXPLOSION DEPENDING UPON CONDITIONS. NEVER USE IF LEAKAGE IS DETECTED.

NEVER OPERATE THE BURNER WITH AN EMPTY FRYPOT. IT ONLY TAKES A FEW MINUTES TO COMPLETELY RUIN A FRYPOT THIS WAY, AND THE FRYTOP WARRANTY WILL BE VOID.

ADJUSTMENTS

The burner used on the fryer is a patented design which does not require primary air adjustment.

INSTALLATION

OPERATING INFORMATION FOR THIS FRYER HAS BEEN PREPARED FOR USE BY QUALIFIED AND/OR PROFESSIONAL OPERATION PERSONNEL.

IN THE EVENT A GAS ODOR IS DETECTED, SHUT DOWN UNITS AT MAIN SHUT OFF VALVE AND CONTACT THE LOCAL GAS COMPANY OR GAS SUPPLIER FOR SERVICE.

Start-Up Procedure

CAUTION

If this is the first time the fryer is being used after installation, refer to Boil-Out Procedure.

CAUTION

The cooking oil/shortening capacity of the RF40 Series fryer is 40 lbs. (20 liters) at 70°F (21°C).

Before lighting the fryer, make sure the fryer is OFF and the frypot drain valve is closed. Remove the basket support rack, if installed, and fill the frypot to the bottom OIL-LEVEL line.

To prevent scorching, if solid shortening is being used, make sure it is tightly packed down into the bottom of the frypot.

Lighting the Pilot on Honeywell Valves:

WARNING: Frypot must be filled with water or shortening before lighting.

1. Turn the thermostat knob to the required frying temperature.
2. Push down on the gas valve knob and turn to the PILOT position.
3. Push the knob in and light the pilot. Continue to push the knob in for about 60 seconds after the flame appears on the pilot. Release the knob. The pilot should remain lit.



Light Pilot Here Gas Valve

INSTALLATION

CAUTION: If the pilot fails to remain lit, wait five minutes before attempting to re-light.

4. With the pilot lit, push down and slowly turn the knob to the ON position.

5. The burner will now light and is controllable by the thermostat.

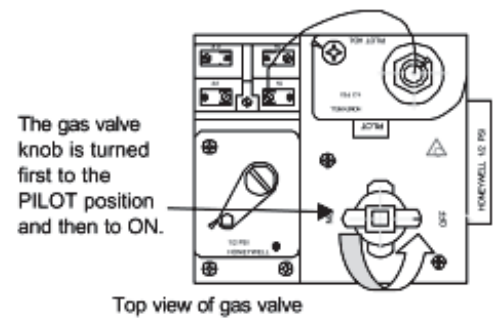

CAUTION: If the pilot and main burner go out, the fryer(s) must be completely shut down at least five minutes before re-lighting.

6. Set the thermostat knob to the desired cooking temperature. The U-shaped burner should light and burn with a strong, blue flame.

THE APPLIANCE AREA MUST BE KEPT FREE AND CLEAR OF COMBUSTIBLES.

HOW TO USE YOUR FRYER

One of the most important considerations in the profitable use of a fryer is the choice of the frying compound used. The best you can buy is actually the least expensive, because it lasts longer than the lower grades and produces fried foods with superior taste and appearance. There are numerous high-grade products available and you are highly urged to use them.

Boiling Out the Frypot

To ensure that the frypot is free of any contamination resulting from its manufacture, shipping, and handling during installation, the frypot must be boiled out before first use. Frymaster recommends boiling out the frypot each time the oil or shortening is changed.

INSTALLATION

DANGER

Never leave the fryer unattended during the boil-out process. If the boil-out solution boils over, turn the fryer off immediately and let the solution cool for a few minutes before resuming the process.

1. Before operating the burner, close fryer drain valve and fill empty frypot with a mixture of cold water and boil-out solution. Fill to the frypot oil-level line.
2. To light fryer, follow lighting instructions in Startup procedure.
3. Set thermostat knob to 275°F (135°C) and turn the fryer gas valve knob to the on position.
4. Simmer the solution for one hour. Caution: NEVER leave the fryer unattended during the boil-out procedure. The solution may foam up and overflow. **To lessen the chance for overflowing, turn the fryer's gas valve knob to the Pilot position occasionally.**
5. After the solution has simmered for one hour, turn the fryer's gas valve knob to the Pilot position and allow the solution to cool.
6. Add one gallon (3.8 liters) of cold water and stir. Drain out the solution into a suitable container and clean the frypot thoroughly.
7. Rinse the frypot at least twice by filling the frypot with clean water and draining. Dry the frypot thoroughly with a clean, dry towel.
8. Refill with shortening.

WARNING

Do not drain boil-out solution into the built-in filtration system. Doing so may cause damage to the filtration pump.

DANGER

Remove all drops of water from the frypot before filling with cooking oil/shortening. Failure to do so may cause spattering of hot liquid when the oil/shortening is heated to cooking temperature.

Filling With Shortening

The RF40 series fryer has a minimum 30 Lbs. (14.5 liters)/ maximum 40 lbs. (19.5 liters) shortening capacity.

1. Ensure the fryer's gas valve is off or in the pilot position.
2. Close the frypot drain valve; remove basket support rack if required.
3. Fill empty frypot to the oil-level line. **When solid shortening is used, it must be thoroughly packed down into the frypot's cold zone.**

INSTALLATION

4. To melt solid shortening without scorching, the burner should be turned ON for about three seconds and OFF for about 10 seconds; alternate until melted. If any smoke is seen during this process, the oil is heating too quickly and scorching. This melting process is not necessary with liquid shortening.

Shutting the Fryer Down

For short-term shut down during the workday, place the fryer's gas valve in the Pilot position and put the frypot covers in place (if the fryer is so equipped).

When shutting the fryers down at closing time, place the fryer power switch in the OFF position, place the gas valve in the OFF position, and put the frypot covers in place (if the fryer is so equipped).

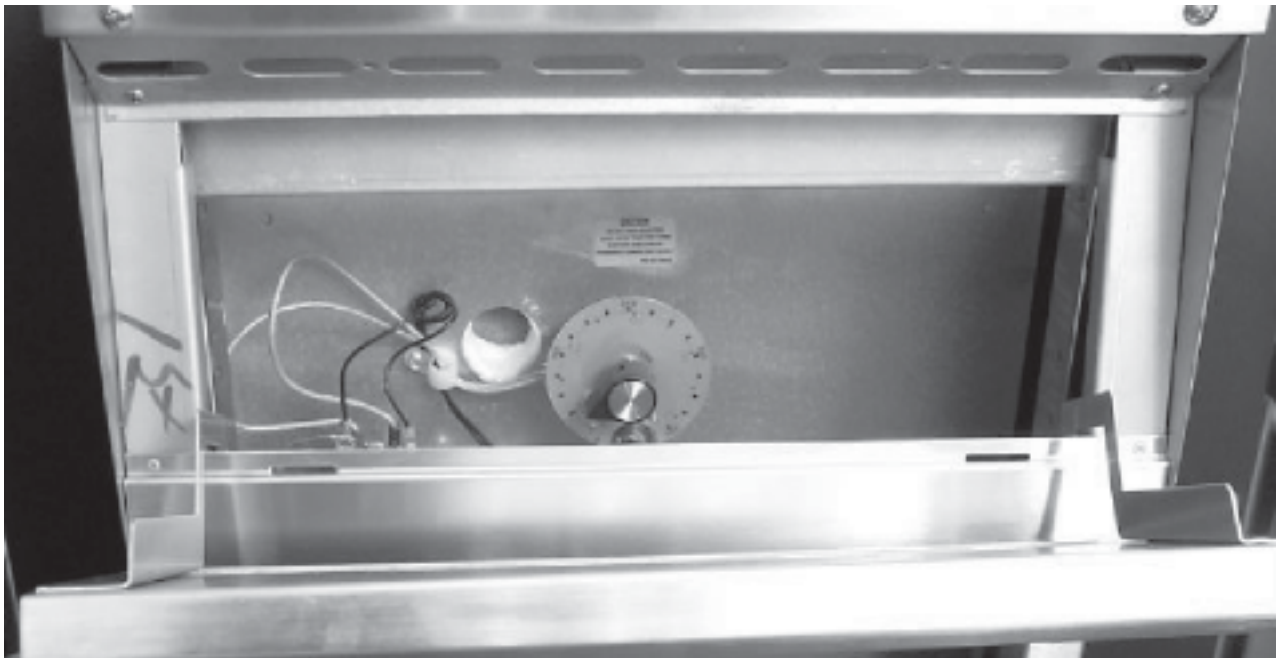

Thermostats

The centerline thermostat on a RF40 is connected to a temperature knob. On the standard model, the knob is attached directly to the thermostat (see photo above). Rotating the knob to the desired cooking temperature (setpoint) directly adjusts the thermostat control to that temperature.

The Thermostat Controller requires no programming, but it may require calibration from time to time. To determine if it requires calibration, refer to Check Thermostat Controller Thermostat Calibration.

OPERATION

For maximum frying compound life, good operators find they do best by frying at the lowest temperature that will give a high-quality product. Thus with a super-fast fryer, such as yours, you do not have to fry potatoes at 375° or 400°, you fry at 325°. A little experimenting will determine just the right temperatures for your menu items.

The worst enemies of frying compound are light, heat, air and salt. Thus, its life can materially be lengthened by keeping the fryer covered when not in use, frying at the lowest temperatures, and by reducing the temperatures during stand-by periods.

A common habit which is harmful to frying compounds is that of salting foods in baskets over the frypot. Also, if food is fried ahead and stored over the frypot to keep hot, as is often done, it will rapidly lose its crispiness and taste greasy.

A common error in frying is to overload the baskets under the mistaken impression that this will increase the production of the fryer. For any given fryer, and any given food product being fried, there is a certain load which will produce the maximum amount of food per hour. For best results, we recommend the baskets be filled between 1/2 and 2/3 full. If the baskets are loaded beyond this, the total hourly production rate will decrease.

To give you a starting point, the following chart suggests the temperatures at which most operators fry certain foods:

FRYING CHART		
PRODUCT	TEMPERATURE	TIME-MINUTES
French Fried Potatoes		
Raw-to done	350	5-7
Blanching	325	4
Browning	350	2
French Fried Onion Rings	360	2-3
Seafood		
Shrimp	360	2-3
Oysters	350	1-4
Scallops	350	3-5
Filletts	350	3-4
Clams	350-360	1-3
Chicken		
Small pieces	350	6-10
Large pieces	320-330	8-11
Cutlets, Chops (1" thick)	325	5-7
Fritters		
Fruit	350	3-5
Vegetable (asparagus, cauliflower, corn, eggplant, tomato)	350	5-8

Draining and Manual Filtering

DANGER

Allow oil/shortening to cool to 100°F (38°C) or lower before draining to an appropriate container for disposal.

The cooking oil or shortening must be drained into another suitable container.

FOR SAFE, CONVENIENT DRAINING AND DISPOSAL OF USED COOKING OIL OR SHORTENING, FRYMASTER RECOMMENDS THE USE OF THE FRYMASTER SHORTENING DISPOSAL UNIT (SDU). THE SDU IS AVAILABLE THROUGH YOUR LOCAL DISTRIBUTOR.

1. Ensure the gas valve is off.
2. Screw the drainpipe (provided with your fryer) into the drain valve. Make sure the drainpipe is firmly screwed into the drain valve and that the opening is pointing down.
3. Position a metal container with a sealable cover under the drainpipe. The metal container must be able to withstand the heat of the cooking oil/shortening and hold hot liquids. If you intend to reuse the oil or shortening, Frymaster recommends that a Frymaster filter cone holder and filter be used when a filter machine is not available. If you are using a Frymaster filter cone holder, be sure that the cone holder rests securely on the metal container.
4. Open the drain valve slowly to avoid splattering. If the drain valve becomes clogged with food particles, use the Fryer's Friend (poker-like tool) to clear the blockage.

DANGER

DO NOT insert anything into the drain from the front to unclog the valve. Hot oil/shortening will rush out, creating an extreme hazard.

WARNING

DO NOT hammer on the drain valve with the Fryer's Friend. This will damage the drain valve ball and prevent the valve from sealing securely, resulting in a leaky valve.

5. After draining the oil/shortening, clean all food particles and residual oil/shortening from the frypot. BE CAREFUL, this material may still cause severe burns if it comes in contact with bare skin.
6. Close the drain valve securely and fill the frypot with clean, filtered or fresh cooking oil or solid shortening to the bottom OIL-LEVEL line.
7. Re-light pilot and return to operation.

DANGER

When using solid shortening, pack the shortening down into the bottom of the frypot. DO NOT operate the fryer with a solid block of shortening sitting in the upper portion of the frypot. This will cause damage to the frypot and may cause a flash fire.

MAINTENANCE

EXTERIOR

Painted Surface: Allow equipment to cool after use and wash with a mild detergent or soap solution. Dry thoroughly with a dry cloth.

Stainless Steel Surface: To remove dirt grease or product residue from stainless steel, use ordinary soap and water (with or without detergent) applied with a sponge or cloth. Dry thoroughly with a clean cloth.

To remove grease and food splatter, or condensed vapors, that have baked on the equipment apply cleanser to a damp cloth or sponge and rub cleanser on the metal in the direction of the polishing lines on the metal. Rubbing cleanser as gently as possible in the direction of the polished lines will not mar the finish of the stainless steel. NEVER RUB WITH A CIRCULAR MOTION. Soil and burnt deposits which do not respond to the above procedure can usually be removed by rubbing the surface with SCOTCH-BRITE scouring pads or STAINLESS scouring pads. DO NOT USE ORDINARY STEEL WOOL as any particles left on the surface will rust and further spoil the appearance of the finish. NEVER USE A WIRE BRUSH, STEEL SCOURING PADS (EXCEPT STAINLESS), SCRAPER, FILE OR OTHER STEEL TOOLS. Surfaces which are marred collect dirt more rapidly and become more difficult to clean. Marring also increases the possibility of corrosive attack.

Darkened areas sometimes appear on stainless steel surfaces where the area has been subjected to excessive heat. These darkened areas are caused by thickening of the protective surface of the stainless steel and are not harmful. Heat tint can normally be removed by the foregoing, but tint which does not respond to this procedure calls for a vigorous scouring in the direction of the polish lines, using SCOTCH-BRITE scouring pads or a STAINLESS scouring pad in combination with a powdered cleanser. Heat tint action may be lessened by not applying or by reducing heat to equipment during slack period.

CARE AND CLEANING OF YOUR FRYER

NEVER OPERATE THE BURNER WITH AN EMPTY FRYPOT. IT ONLY TAKES A FEW MINUTES TO COMPLETELY RUIN A FRYPOT THIS WAY, AND THE FRYPOT WARRANTY IS VOID IF THIS IS DONE.

The frying compound should be filtered at least once a day. If a heavy volume of breaded food is fried, it may be necessary to filter two or more times a day. This will increase the life of the frying compound and produce better tasting food. Filter cones are ideal for this and are inexpensive and readily obtainable from your dealer.

The fryer should be cleaned daily. This operation can be combined with filtering the frying compound. After the fryer is drained, wipe the inside with a cloth saturated in FRYER 'N' GRIDDLE CLEANER, then rinse thoroughly. Wipe dry and put the filtered compound back in the frypot. The frypot should be boiled out once a week with FRYER 'N' GRIDDLE CLEANER according to directions on the bottle. Each day wipe down the controls and all inside the door with a damp cloth. Remove the basket hanger and clean at least once a week. This way your fryer will stay clean and new looking much longer.

Daily Checks and Services

Inspect Fryer and Accessories for Damage

Look for loose or frayed wires and cords, leaks, foreign material in frypot or inside cabinet, and any other indications that the fryer and accessories are not ready and safe for operation.

Inspect the ceramic burner targets. Ensure the targets are in position above each orifice, and that the flame ignites approximately 2½ inches (60mm) above the orifice. The flame should strike the center of the target and be a rich blue color. Call your Montague Company Authorized Service Agency if you see any problems.

Clean Fryer Cabinet Inside and Out

Clean inside the fryer cabinet with dry, clean cloth. Wipe all accessible metal surfaces and components to remove accumulations of oil or shortening and dust.

Clean the outside of the fryer cabinet with a clean, damp cloth soaked with dishwashing detergent, removing oil/shortening, dust, and lint from the fryer cabinet.

DANGER

Never attempt to clean fryer during the cooking process or when the frypot is filled with hot oil/shortening. If water comes in contact with oil/shortening heated to cooking temperature, it can cause the oil/shortening to splatter and severely burn nearby personnel.

Filter Cooking Oil/Shortening

The cooking oil/shortening used in your fryer should be filtered at least once every day (more often if the fryer is in constant use). Refer to the Operation Section, Filtration Instructions, for details.

Quarterly Checks and Services

Drain and Clean Frypot

During normal usage of your fryer, a deposit of carbonized cooking oil or shortening will gradually form on the inside of the frypot. This deposit must be periodically removed to maintain your fryer's efficiency.

DANGER

Allow oil/shortening to cool to 100°F (38°C) or lower before draining to an appropriate container for disposal.

MAINTENANCE

The cooking oil or shortening must be drained into another suitable container.

FOR SAFE, CONVENIENT DRAINING AND DISPOSAL OF USED COOKING OIL OR SHORTENING, FRYMASTER RECOMMENDS THE USE OF OUR SHORTENING DISPOSAL UNIT (SDU). THE SDU IS AVAILABLE THROUGH YOUR LOCAL DISTRIBUTOR.

1. Ensure gas valve is OFF.
2. Screw the drainpipe (provided with your fryer) into the drain valve. Make sure the drainpipe is firmly screwed into the drain valve and that the opening is pointing down.
3. Position a metal container with a sealable cover under the drainpipe. The metal container must be able to withstand the heat of the cooking oil/shortening and hold hot liquids. If you intend to reuse the oil or shortening, Frymaster recommends that our filter cone holder and filter cone be used when a filter machine is not available. If you are using a Frymaster filter cone holder, be sure that the cone holder rests securely on the metal container.
4. Open the drain valve slowly to avoid splattering. If the drain valve becomes clogged with food particles, use the Fryer's Friend (poker-like tool) to clear the blockage.

DANGER

DO NOT insert the tool into the drain from the front to unclog the valve. Hot oil/shortening will rush out, creating an extreme hazard.

WARNING

DO NOT hammer on the drain valve. This will damage the drain valve ball and prevent the valve from sealing securely, resulting in a leaky valve.

5. After draining the oil/shortening, clean all food particles and residual oil/shortening from the frypot. BE CAREFUL, this material may still cause severe burns if it comes in contact with bare skin.
6. Close the drain valve securely and fill the frypot with a solution of detergent and water to the bottom OIL-LEVEL line. (Frymaster recommends the use of Frymaster Boilout Solution, available through your local distributor, for best results.)
7. Relight the pilot.
8. Set the thermostat to 280°F.
9. Slow the rate at which the frypot heats by occasionally turning the gas valve to pilot.

MAINTENANCE

10. Set the thermostat to 280°F (138°C).

11. Simmer the solution for 1 hour.

WARNING

Never leave the fryer unattended during this process. If the solution overflows, turn the gas valve off immediately.

12. After the solution has simmered for 1 hour, turn the gas valve to the OFF position and allow the solution to cool.

13. Drain the solution into a suitable container (**NOT the Shortening Disposal Unit**) and then roughly wipe the frypot with a clean towel.

14. Close the drain valve and fill the frypot with clean, cold water and drain. Repeat the rinse process again, and then wipe frypot with a clean, dry towel.

15. Refill with shortening.

DANGER

Ensure that the frypot is completely free of water before filling with cooking oil or shortening. When the oil or shortening is heated to cooking temperature, water in the frypot will cause splattering.

Clean Detachable Parts and Accessories

As with the frypot, a deposit of carbonized oil/shortening will accumulate on detachable parts and accessories such as baskets, sediment trays.

Wipe all detachable parts and accessories with a clean cloth dampened with a detergent solution. (Frymaster recommends the use of Frymaster Fryer 'N' Griddle Cleaner, available through your local distributor, for best results.) Rinse and thoroughly dry each part.

Check Calibration of Thermostat Knob

1. Set the temperature control knob to frying temperature.

2. Let the burner cycle on and off automatically three times in order for the cooking oil/shortening temperature to become uniform. If necessary, stir to get all shortening in the bottom of the frypot melted.

3. Insert a good-grade thermometer or pyrometer probe into the oil/shortening, with the end touching the fryer temperature-sensing probe.

MAINTENANCE

4. When the burner starts for the fourth time, the thermometer/pyrometer reading should be within $\pm 5^{\circ}\text{F}$ (2°C) of the temperature knob setting. If it is not, calibrate as follows:

- a. Loosen the setscrew in the temperature control knob until the knob will rotate freely on its shaft.
- b. Rotate the knob until the index line on the knob is aligned with the marking that corresponds to the thermometer or pyrometer reading.
- c. Hold the knob and carefully tighten the setscrew.
- d. Recheck the thermometer/pyrometer reading against the temperature control knob setting the next time the burner comes on.
- e. Repeat steps 4.a. through 4.d. until the thermometer/pyrometer reading and knob setting agree within $\pm 5^{\circ}\text{F}$ (2°C).

5. Remove the thermometer or pyrometer.

If calibration cannot be obtained for any reason, call a Montague Company Authorized Service Agency for assistance.

Check Thermostat Calibration

1. Set the temperature control knob to 325°F (162°C) and insert a good grade thermometer or pyrometer into the frypot so that it touches the thermostat.
2. When the burner cycles off, set the temperature control knob to 340°F (170°C). As the reading on the thermometer or pyrometer nears the control knob setting, but before the burner cycles off, reset the knob to 325°F (162°C). Just as the reading on the thermometer or pyrometer drops below 325°F (162°C), the burner should cycle on. If it does not, calibration is required. Call your Montague Company Authorized Servicer to arrange this service.

Clean Gas Valve Vent Tube

1. Carefully unscrew the vent tube from the gas valve. NOTE: The vent tube may be straightened for ease in removal.
2. Pass a piece of ordinary binding wire (.052 inch diameter) through the tube to remove any obstruction.
3. Remove the wire and blow through the tube to ensure it is clear.
4. Reinstall tube and bend it so that the opening is pointing downward.

Semi-Annual Checks and Service

Check Burner Manifold Pressure

WARNING
This task should be performed by qualified service personnel only.

1. Ensure that the gas valve knob is in the OFF position.
2. Remove the pressure tap plug from burner manifold. (see photo).
3. Insert the fitting for a gas-pressure measuring device into the pressure tap hole.



A manometer or water column pressure gauge meter is connected to the manifold here.

WARNING
The frypot must be filled with shortening or water during this procedure.

4. Place the gas valve in the PILOT position and light. When the burner lights and continues to burn, note gas pressure reading and compare to the accompanying tables.
5. To adjust burner gas pressure, remove the cap from the gas valve regulator adjustment screw.
6. Increase the setting on the thermostat until the burner comes on.
7. Monitor the gas pressure reading on the man-ometer or pressure gauge.
8. Adjust the gas valve regulator adjustment screw to obtain the prescribed pressure. See the Rating Plate. Turning the screw clockwise increases pressure, counterclockwise decreases pressure.

Burner Manifold Gas Pressures	
Gas	Pressure
Natural	4.0" W.C. 0.73 kPa
LP	8.25" W.C. 2.05 kPa

MAINTENANCE

9. Install the gas valve regulator cap screw when the correct manifold pressure is obtained.
10. Place the gas valve in the OFF position. Remove the fitting from the pressure tap hole and reinstall the pressure tap plug.
11. Place the gas valve in the Pilot position. Re-light and check for any gas leaks.
12. Place the gas valve in the OFF position.

Annual/Periodic System Inspection

This appliance should be inspected and adjusted periodically by qualified service personnel as part of a regular kitchen maintenance program.

The Montague Co. recommends that this appliance be inspected at least annually by a Montague Company Authorized Service Technician as follows:

Fryer

- Inspect the cabinet inside and out, front and rear for excessive oil build-up and/or oil migration.
- Verify that the flue opening is not obstructed by debris or accumulations of solidified oil or shortening.
- Verify that burners and associated components (i.e. gas valves, pilot assemblies, etc.) are in good condition and functioning properly. Inspect all gas connections for leaks and verify that all connections are properly tightened.
- Verify that the burner manifold pressure is in accordance with that specified on the appliance's rating plate.
- Verify that the temperature and high-limit probes are properly connected, tightened and functioning properly, and that mounting hardware and probe guard are present and properly installed.
- Verify that component box components (i.e. computer/controller, transformers, relays, interface boards, etc.) are in good condition and free from oil migration build-up and other debris. Inspect the component box wiring and verify that connections are tight and that wiring is in good condition.
- Verify that all safety features (i.e. drain safety switches, reset switches, etc.) are present and functioning properly.
- Verify that the frypot/cookpot is in good condition and free of leaks and that the frypot/cookpot insulation is in serviceable condition.

NOTE: This guide does not include every possible problem and cause. Careful observation of all malfunction indications are logical troubleshooting will be helpful in correcting the problem. See Service Procedures to replace fryer components.

Problem	Probable Cause	Corrective Action
Thermostat does not call for heat, does not energize gas control valve at all	A. Pilot not lit	A. Light pilot
	B. Bad gas valve B. Replace gas valve	B. Replace gas valve
	C. Thermostat wires damaged or broken	C. Repair or replace thermostat wires
	D. Thermostat set too low.	D. Increase thermostat setting
	E. Thermostat out of calibration	E. Recalibrate. See Service Procedures.
	F. Thermostat bad	F. Replace thermostat
Thermostat does not control at set point	A. Thermostat out of calibration.	A. Recalibrate thermostat. See Service Procedures
	B. Contaminated thermostat contacts	B. Replace thermostat
Pilot Outage	A. Automatic gas valve knob turned to OFF position	A. Turn gas valve to pilot position, light pilot
	B. Low pilot flame (will not hold pilot)	B. Adjust pilot flame to 11/2" in (38 mm)
	C. Clogged pilot orifice.	C. Remove, clean pilot orifice. Reinstall.
	D. Pilot burner clogged around pilot generator.	D. Remove pilot burner. Clean burner
	E. Pilot flame blowing away from pilot generator (excessive draft in kitchen).	E. Eliminate draft in kitchen
	F. Pilot generator not inserted fully into pilot burner.	F. Reinsert pilot generator into pilot burner until flame surrounds tip.
	G. Pilot generator low output	G. Replace pilot generator
	H. High resistance in hi-limit thermostat contacts.	H. Replace hi-limit thermostat
	I. Defective pilot magnet in gas valve.	I. Replace gas valve.
	J. Corroded connection where pilot generator connects to gas valve.	J. Clean pilot generator connection at gas valve.

SERVICE

Problem	Probable Cause	Corrective Action
Main burner will not come on; pilot remains lit	A. Loose, dirty or corroded terminals on gas valve.	A. Clean and tighten terminals on gas valve.
	B. Loose, dirty or corroded terminals on thermostat	B. Clean and tighten terminals on thermostat.
	C. High resistance in contacts of thermostat.	C. Replace thermostat. Call for service.
	D. Thermostat out of calibration.	D. Calibrate thermostat. See Service Procedures.
	E. Automatic gas valve defective.	E. Replace automatic gas valve.
	F. Automatic gas valve knob turned to pilot position.	F. Turn gas valve knob to ON position.
Main burner does not light all the way around	A. Burner flame deflector broken off.	A. Install new burner flame deflector.
	B. Burner gas pressure too high or too low.	B. Adjust gas pressure. Natural: 4.0 in. W.C. (0.99kPa); LP: 10.0 in W.C. (2.49kPa).
	C. One or more main burner orifices clogged	C. Clean burner orifices and blow out with compressed air.
	D. Fryer flue connected directly to vent hood with a chimney-like duct.	D. Remove chimney-like duct and allow for at least 18 inches (45.7 cm) between flue outlet and vent hood filters.
	E. Blocked flue	E. Clear blockage from flue.
Delayed ignition of main burner	A. One or more burner flame deflectors broken.	A. Install new burner flame deflectors.
	B. Pilot flame low — less than 1 inch (25mm)	B. Adjust pilot flame to 1 ½ in (38mm).
	C. Pilot flame directed away from first orifice on burner.	C. Reposition pilot hood to direct flame toward first burner orifice.
	D. Fryer incoming gas pressure too low.	D. Have local gas company raise incoming gas to the proper pressure.
	E. Fryer's incoming gas line too small.	E. Replace incoming gas line with proper size.
	F. One or more burner orifice clogged.	F. Clean burner orifices with proper orifice drill.
Flame rolling out under fryer	A. Flue obstructed. A. Gas valve pilot magnet too weak.	A. Clean obstruction from flue. Flame rolling out under fryer.
	B. Too little make-up air in kitchen.	B. Increase make-up air.
Pilot light remains lit when gas valve is pushed in, but goes out when released.	A. Flue obstructed.	A. Replace gas valve.
	B. Pilot generator has low millivolt output.	B. Replace pilot generator
	C. Hi-limit thermostat stuck open.	C. Replace hi-limit thermostat.
	D. Loose, dirty or corroded hi-limit wires.	D. Clean/tighten hi-limit wires on gas valve.

Functional Description

The RF40 Series fryers contain a welded steel stainless frypot that is directly heated by gas flames that are diffused evenly over its lower surface by ceramic deflectors (targets).

The flames originate from orifices in a U-shaped burner manifold positioned beneath the frypot. The orifice diameters differ for natural and LP gas as indicated in the accompanying table.

RF40 Series Orifice Sizes (0-1999 ft/609 m)		
Gas	# DS	Millimeters
Natural (G20/25)	51	1.70 mm
LP (G31)	57	1.10 mm

Gas flow to the manifold is regulated by an electromechanical gas valve. This series of fryers is equipped with a millivolt gas valve and all models use a pilot ignition system.

Pilot Ignition System

The pilot ignition system is made up of the pilot orifice, pilot hood, and a thermopile. The pilot serves two purposes: light the burner and heat the thermopile. In operation, the thermopile is in contact with the pilot flame and generates millivolts. The millivolt output passes through a normally closed high-limit switch and energizes the gas valve pilot coil, which in turn opens the pilot valve. If the pilot flame is extinguished, voltage is lost to the gas valve pilot coil and the pilot valve closes

Thermostats

Fryers equipped with thermostat controls have an adjustable *controlling (operating) thermostat*. The temperature at which the thermostat opens and closes is adjusted by physically changing the setting of the thermostat itself by means of an attached knob. The Fenwal controlling thermostat used in the RF40 Series fryers is sensitive to one-degree changes in temperature.

All RF40 Series fryers are equipped with a *high-limit thermostat*. In the event that the fryer fails to properly control the oil temperature, the high-limit thermostat prevents the fryer from overheating to the flash point. The high-limit thermostat acts as a normally closed power switch that opens when exposed to temperatures above 425°F to 450°F (218°C to 232°C).

SERVICE

Accessing Fryers for Servicing

DANGER

Moving a fryer filled with cooking oil/shortening may cause spilling or splattering of the hot liquid. Follow the draining instructions in of this manual before attempting to relocate a fryer for servicing.

1. Drain shortening from fryer.
2. Shut off the gas supply to the unit. Unplug the power cord(s) if equipped.
Disconnect the unit from the gas supply.
3. Remove any attached restraining devices.
4. Relocate the fryer for service accessibility.
5. After servicing is complete, reconnect the unit to the gas supply, reattach restraining devices, and plug in the electrical cords.
6. Refill with shortening.

Cleaning the Gas Valve Vent Tube

Refer to Semi-Annual Checks and Services in Preventive Maintenance.

Checking the Burner Manifold Gas Pressure

Refer to Semi-Annual Checks and Services in Preventive Maintenance.

Adjusting Burner Ceramic Target Spacing and Alignment

DANGER

Drain the frypot or remove the handle from the drain valve before proceeding further.

Proper spacing of the top edge of the burner ceramic targets is $\frac{3}{4}$ inch (13 mm) from the frypot side. To adjust target spacing, bend the brackets to which they are attached away or toward the frypot to the proper distance. (A length of board of the proper thickness is useful as a gauge to verify spacing and alignment.)

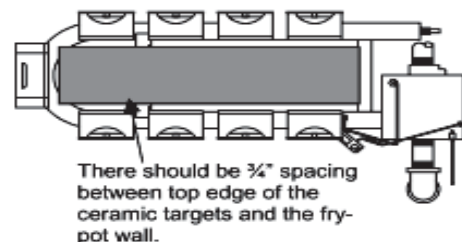

Adjusting the Pilot Flame

Gas Valves

1. For Gas Valves, remove the screw from the pilot adjustment screw hole on the gas valve.
2. Using a small, flat-tipped screwdriver, turn the pilot adjustment screw counterclockwise to increase the length of the flame or clockwise to decrease the length of the flame. Adjust flame to a length of 1 to 1½ inches (25 to 38mm).
3. Reinstall the pilot adjustment screw cap.

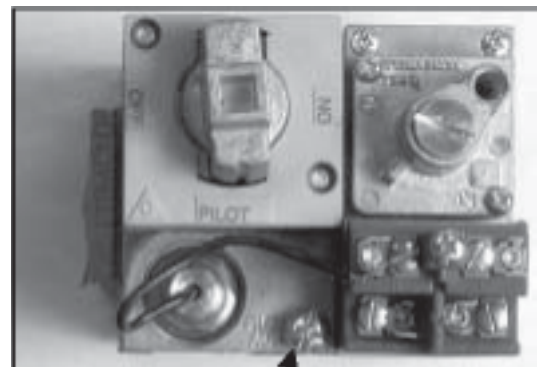

The pilot adjustment on the Honeywell valve for US fryers is under this screw.

Calibrating the Thermostat Control

1. Fill the frypot to the lower OIL-LEVEL line with cooking oil/shortening. If solid shortening is used, it must be tightly packed into the frypot before starting calibration procedure.
2. Light the pilot. (Refer to Chapter 3 for detailed lighting instructions.)
3. Insert a good grade thermometer or pyrometer into the frypot, about one inch from the thermo-stat.
4. Set the thermostat to 325°F.

SERVICE

6. Take a pyrometer reading when the burners extinguish for the third time.
7. Loosen the setscrews in the thermostat knob and turn knob to the temperature established by the pyrometer reading.
8. Allow burners to cycle on and off three more times and recheck pyrometer reading against thermostat setting. Temperature readings should be within 5°F.

Replacing Fryer Components

Replacing the Operating Thermostat

1. Drain fryer and turn gas off.
2. Use an allen wrench to loosen setscrew at the side of the thermostat knob. Remove the thermostat knob.
3. Remove the two setscrews on either side of the thermostat shaft and remove the dial plate.
4. Disconnect the thermostat wires from gas valve.
5. Use a slotted socket to unscrew the thermostat from the frypot.
6. Apply a small amount of Loctite PST56765 compound to the threads of the new thermostat. Install the thermostat.
7. Recalibrate.



Setscrews hold the knob and the dial plate to the thermostat. Use an allen wrench to remove both.

HIGH LIMIT CONTROL

The fryer is equipped with a high limit control which is located behind the front panel. The function of the high limit control is to shut down the unit in the event of a thermostat failure which would allow the cooking oil to be overheated. The operating limit of this safety control is between 440°F to 460°F.

In the event of a high limit “shut down”, the entire system will be put out of operation and relighting the pilot will be required (refer to lighting instructions).

DO NOT attempt to relight the pilot until the oil temperature has lowered to approximately 350°F.



The high-limit thermostat is below the thermostat dial on the RF40.

Replacing the High-Limit Thermostat

1. Drain fryer and turn gas off.
2. Disconnect wires at the gas valve.
3. Use a slotted socket to unscrew the thermostat from the frypot.
4. Apply a small amount of Loctite PST56765 compound to the threads of the new thermostat.
5. Install the new high-limit thermostat.

CAUTION

The operating thermostat must be calibrated after installation is complete. Refer to calibration instructions.

SERVICE

Replacing Burner Ceramic Targets

DANGER

Drain the frypot or remove the handle from the drain valve before proceeding further.

1. Disconnect fryer from gas supplies.
2. Carefully remove accessories as necessary to expose burner.
3. Disconnect the wires from the gas valve terminal block, marking each wire to facilitate reconnections.
4. Remove the high-limit thermostat wires from the gas valve pilot coil.
5. Disconnect the pipe union collar at the right side of the gas valve.

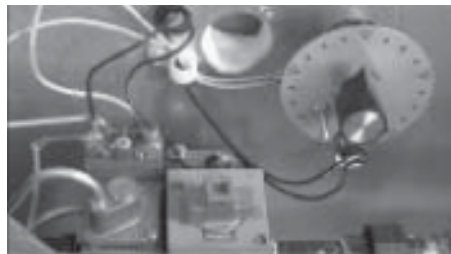

These screws on either side of the drain valve must be removed to lower the burner from the frypot.

6. Remove the burner heat shield hanger screws at the front of the burner and remove the heat shield.
7. Remove the burner hanger screws and lower the front of the main burner. Pull it forward to clear the rear burner hanger, then lower the burner to the floor.
8. Raise the front of the fryer enough to slide the burner from under the fryer cabinet.
9. To replace only the ceramic targets, straighten the target locking tabs with a pair of needle nose pliers or a screwdriver, and slide the target up and off the bracket. Slide the replacement target onto the bracket and bend the locking tabs down.

To replace the entire target assembly, use a ½-inch (13mm) box end wrench to remove the brass orifice that holds the assembly to the burner manifold. Position the new assembly and replace the orifices.

The complete burner assembly: Removing target assemblies requires removing the orifice that holds them in place.

Wires connecting the valve to the thermocouple must be disconnected.

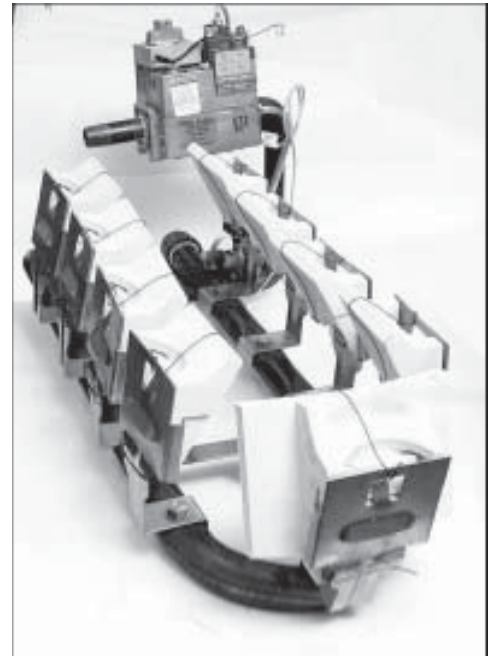

WARNING
Use extreme care to prevent cross-threading and stripping when reinstalling the brass orifices.

10. Reverse steps to reinstall the burner assembly. Check spacing and alignment of targets in accordance with the section: Adjusting Burner Ceramic Target Spacing and Alignment.

SERVICE

Replacing the Gas Valve

DANGER

Drain the frypot or remove the handle from the drain valve before proceeding further.

1. Disconnect fryer from electrical and gas supplies
2. Disconnect the wires from the gas valve terminal block, marking each wire to facilitate reconnections.
3. Remove the high-limit thermostat wire from the gas valve pilot coil.
4. Disconnect the pilot gas line fitting from the gas valve.
5. Disconnect the pipe union collars to the left and right of the gas valve and remove the valve.
6. Remove the pipefittings from the old gas valve and install on the replacement valve, using Loctite™ PST56765 or equivalent pipe thread sealant on threads.
7. Reverse steps 1-5 to install the replacement gas valve.



Gas valve in the RF40.

Replacing the Pilot Assembly or Thermopile

DANGER

Drain the frypot or remove the handle from the drain valve before proceeding further.

1. Remove the burner assembly in accordance with steps 1-8 of the Replacing Burner Ceramic Targets.
2. To replace only 2. To replace only the thermopile:
 - a. Bend the clip at the bottom of the pilot assembly and press the thermopile out of the pilot assembly from the top.
 - b. Disconnect the thermopile fitting from the gas valve pilot coil.
 - c. Reverse steps a and b to install the replacement thermopile.



Clip used to remove thermopile.

3. To replace the complete pilot assembly:
 - a. Disconnect the pilot tubing from the bottom of the pilot assembly.
 - b. Remove the screw from the pilot-mounting bracket to release the pilot assembly.
 - c. Disconnect the thermopile fitting from the gas valve pilot coil.
 - d. Reverse steps a through c to install the replacement pilot assembly.
4. Reinstall the burner assembly by reversing steps 1-8 of Replacing Burner Ceramic Targets.

Replacing the Frypot

1. Drain the frypot.
2. Remove all accessories (e.g., frypot covers, basket lift arms, etc.) and hi-back from the fryer.
3. Disconnect the fryer from gas supplies.
4. Remove the screws from the control panel and lift it from the fryer(s).
5. Remove nuts from the left and right side underneath the top front edges.
6. Remove tubing from gas train.
7. Pull worksurface and frypot assembly forward to disengage from rear hold-downs.
8. Lift frypot complete with burner, gas valve, flue, drain valve and combustion chamber from the fryer cabinet. After lifting the frypot partially out of the cabinet, tilt the front downward to allow the drain valve to pass by the cabinet top and front crossbar.
9. Remove the drain valve, hi-limit, and operating thermostat and transfer them to the replacement frypot. Before installing thermostats and drain valve on the replacement frypot, clean threads and apply Loctite PST56765 thread sealant to the threads.
10. Reverse the previous procedures to install the new frypot.

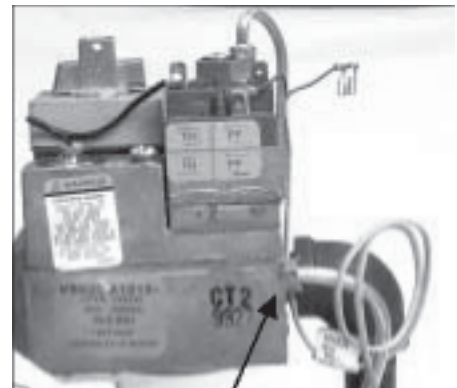

Gas line for pilot.

SERVICE

CAUTION

Before installing thermostat/temperature probe, high-limit thermostat, and drain valve on replacement frypot, clean their threads and apply Loctite™ PST56765 thread sealant or equivalent to the threads.

Troubleshooting and Problem Isolation

This section is intended to provide technicians with a general knowledge of the broad problem categories associated with this equipment, and the probable causes of each. With this knowledge, the technician should be able to isolate and correct any problem encountered.

Problems you are likely to encounter can be grouped into these broad categories:

1. Pilot failures
2. Improper burner functioning
3. Improper temperature control
4. Leakage problems

The probable causes of each category are discussed in the following sections. A series of Troubleshooting Guides is included at the end of the chapter to assist in identifying some of the more common problems.

Pilot Failures

There are two categories: no pilot flame; unreliable flame

No flame

1. No gas or insufficient gas supply
2. Clogged pilot orifice
3. Air in gas lines (usually in new installations)

Unreliable flame

1. Open or grounded high limit
2. Loose/corroded wire connections
3. Low or no voltage out of thermopile
4. Bad gas valve

Problems Related to the Gas and/or Electrical Current

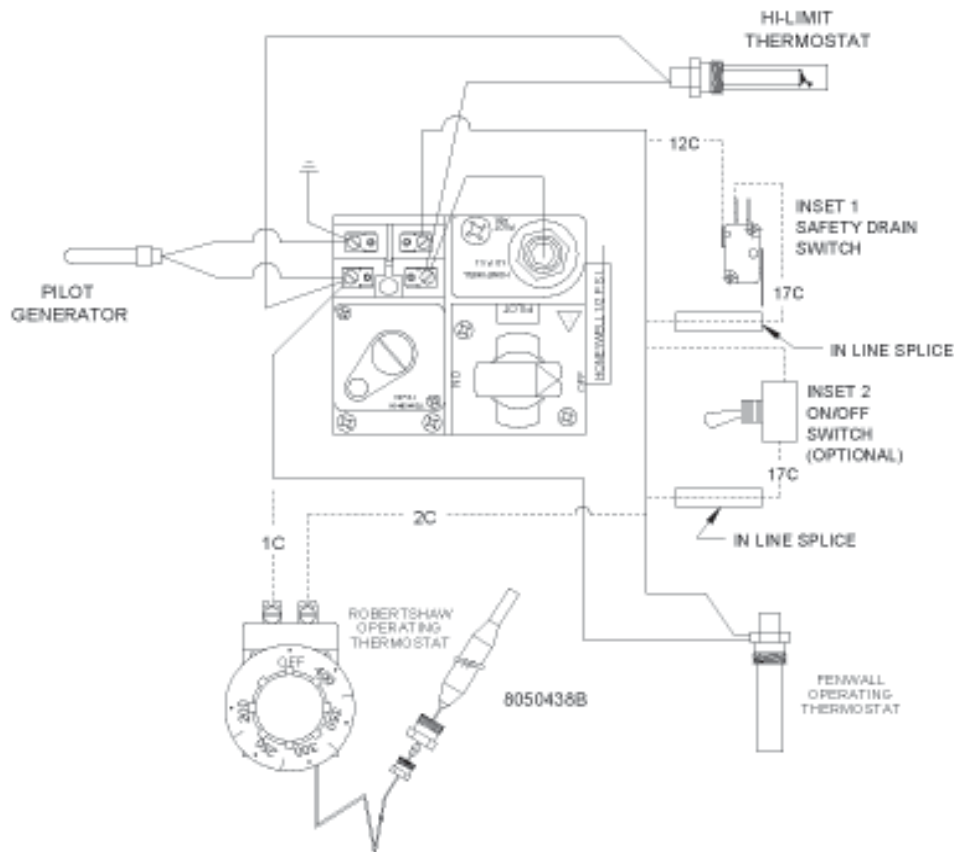

The main indicator of a gas or electrical circuit problem is an entire battery of fryers fails to light. Verify that the quick disconnect hose is properly connected, the fryer is plugged in, the main gas supply valve is open.

Problems Related to the Electrical Circuits

If gas is being supplied to the fryer, the next most likely cause of ignition failure is a problem in the millivolt circuit of the pilot system. If the fryer is equipped with a Filter Magic II filtration system, first verify that the drain valve is fully closed. (The valve is attached to a microswitch that must be closed for power to reach the gas valve. Often, although the valve handle appears to be in the closed position, the microswitch is still

The drain linkage is attached to a microswitch, which prevents the fryer from operating if the drain valve is open

SERVICE

Problems Related to the Gas Valve

If the problem is not in the millivolt circuit of the pilot system, it is most likely in the gas valve itself.

Follow these steps to check a Honeywell valve:

1. Complete System Check: With thermostat contacts closed and gas cock dial “ON,” main burner should ignite. If not measure across terminals 2 and 3 as indicated by the diagram. If the reading is more than 180MV, replace the gas valve.

2. System Resistance Check: With thermostat contacts closed and main burner “ON”, measure the millivolts between terminals 1 and 3 as indicated by the diagram. Reading should not be greater than 220MV, If greater, re-check thermostat leads and connections. Replace with new or heavier gauge wires if necessary. If the reading is still greater than 220MV, replace the thermostat.

3. Automatic Pilot Dropout Check: With thermostat contacts open, depress gas cock knob with pilot lit until maximum millivolt output is observed between terminals 1 and 2. Extinguish the pilot and observe the meter. The sound of the pilot magnet dropping should be audible. The dropout should occur between 110 MV and 36MV. If the dropout occurs outside those limits, replace the gas valve.

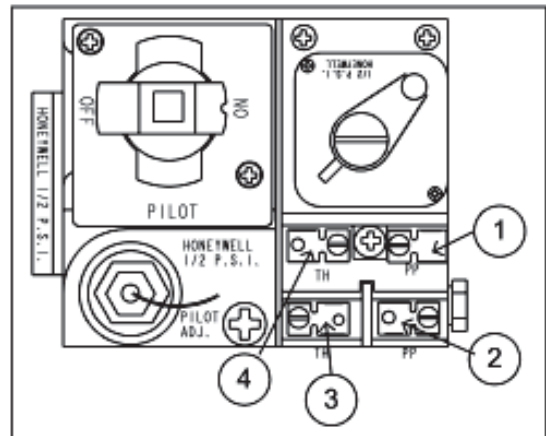

Test	Meter Setting	Meter leads on terminals		Acceptable Results
1	MV	2	3	Less than 180MV
2	MV	1	3	Less than 220MV
3	MV	1	2	110-36 MV

Follow these steps to troubleshoot a Robertshaw Valve:

1. Complete System check: With thermostat contacts closed and gas cock dial “ON”, main burner should ignite. If not, measure across TP and TH terminals. If the reading is more than 100 MV, replace the gas valve.

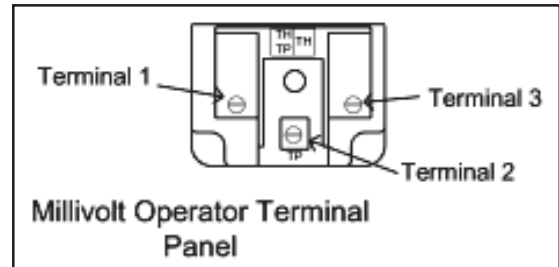

2. System Resistance Check: With thermostat contacts closed and main burner “ON”, measure the millivolt reading between THTP and TH terminals. Reading should be less than 80MV. If not, recheck thermostat leads and connections. Replace with new or heavier gauge wires if necessary. If the reading is still greater than 80 MV, replace the thermostat.

3. Automatic Pilot Dropout Check: With thermostat contacts open, depress gas cock knob with pilot lit until maximum millivolt output is observed between terminals THTP and TP. Extinguish the pilot and observe the meter. The sound of the pilot magnet dropping should be audible. The dropout should occur between 120MV and 30MV. If outside these limits, change the gas valve.

Test	Meter Setting	Meter leads on terminals		Acceptable Results
1	MV	TP	TH	Less than 100MV
2	MV	THTP	TH	Less than 80MV
3	MV	THTP	TP	120-30 MV

Improper Burner Functioning

The **burner lighting on one side only** may be caused by a missing or misaligned rear deflector target or improper burner manifold pressure. Clogged burner orifices are usually the cause of **gaps in burner firing**.

Fluctuating flame intensity is normally caused by either improper or fluctuating incoming gas pressure, but may also be the result of variations in the kitchen atmosphere. Verify incoming gas pressure in the same way as for “popping,” discussed in the preceding paragraphs. Variations in the kitchen atmosphere are usually caused by air conditioning and/or ventilation units starting and stopping during the day. As they start and stop, the pressure in the kitchen may change from positive or neutral to negative, or vice versa. They may also cause changes in airflow patterns that may affect flame intensity.

SERVICE

Flames “rolling” out of the fryer are usually an indication of negative pressure in the kitchen. Air is being sucked out of the fryer enclosure and the flames are literally following the air. If negative pressure is not the cause, check for high burner manifold gas pressure in accordance with the procedures in Maintenance Section. An obstructed flue, which prevents the fryer from properly exhausting, may also be the cause.

An **excessively noisy burner**, especially with **flames visible above the flue opening**, may indicate that the burner gas pressure is too high, or it may simply be that the gas valve vent tube is blocked. If the gas pressure is correct and the vent tube is unobstructed, the gas valve regulator is probably defective.

Occasionally a burner may apparently be operating correctly, but nevertheless the fryer has a **slow recovery rate** (the length of time required for the fryer to increase the oil temperature from 275°F to 325°F (135°C to 163°C)). The primary causes of this are low burner manifold pressure and/or misaligned or missing deflector targets. If both of these causes are ruled out, the probable cause is a gas valve regulator that is out of adjustment. Refer to the **Check Burner Manifold Pressure** procedure in the semi-annual checks and services section.

Improper Temperature Control

Temperature control is a function of several interrelated components, each of which must operate correctly. The principle component is the thermostat.

For problem isolation techniques, refer to the troubleshooting guides **TROUBLESHOOTING THE THERMOSTAT**.

Failure to Control at Setpoint

The problem will be with the thermostat itself. Possible causes are that the thermostat is out of calibration, the knob or flexible shaft is loose on the thermostat shaft, a thermostat wire is disconnected or broken, or the thermostat is defective. Refer instructions on calibrating the thermostat.

Leakage Problems

Leakage of the frypot almost always will be due to improperly sealed high-limit switches, thermostats/ temperature probes, and drain fittings. When installed or replaced, each of these components must be sealed with Loctite™ PST56765 sealant or equivalent to prevent leakage. In very rare cases, a leak may develop along one of the welded edges of the frypot. When this occurs, the frypot must be replaced.

If the sides and/or ends of the frypot are coated with oil/shortening, the most likely cause is spillage over the top of the frypot rather than leakage.

The clamps, which hold the drain tube sections together, may loosen over time as the tubes expand and contract during use. If the section of drain tube connected to the drain valve is removed for whatever reason, make sure that its grommet is in good condition and properly fitted around the nipple of the drain when it is reinstalled. Also, ensure that the drain tube runs downward from the drain along its whole length and has no low points where oil or shortening may accumulate.

SERVICE

BURNER COMPONENTS

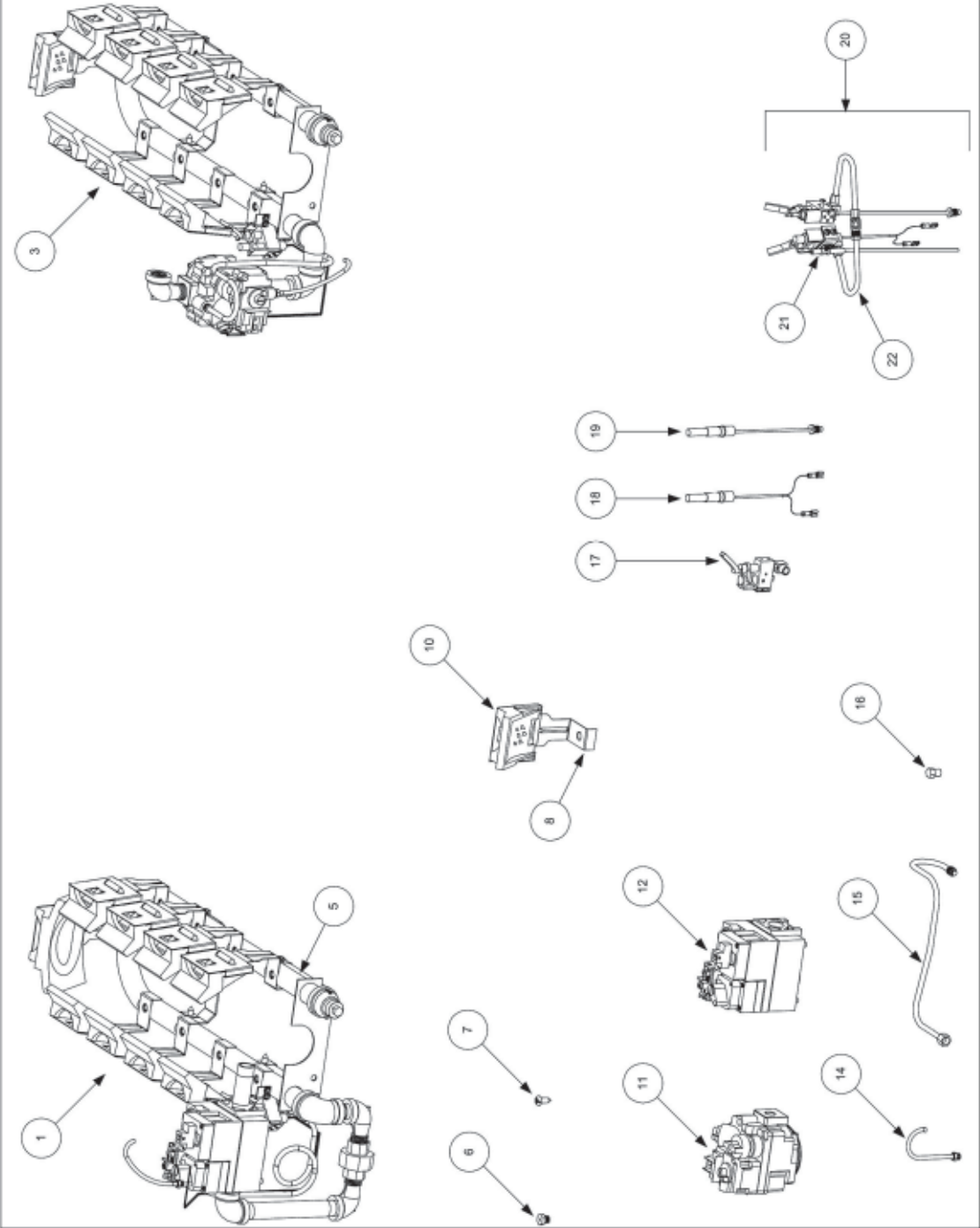

- 3 Burner Assembly, RF40, Complete with Gas Valve
 - 106-0237 Natural Gas
 - xxx-xxxx Propane Gas
- 5 810-1862 Manifold, RF40
- 6 Orifice
 - 810-0129 Natural Gas (#51DS), 1.70mm
 - xxx-xxxx Propane Gas (#57DS) 1.10mm
- 7 809-0170 Screw, Deflector (Target) Mounting Bracket
- 8 910-1465 Bracket, Deflector (Target) Mounting
- 10 814-0034 Ceramic Deflector (Target), Side and Small Rear
- 11 Discontinued Gas Valve, Robertshaw Millivolt (Use conversion kit 826-1579 for Natural Gas or 826-1580 for Propane Gas)
- 12 Gas Valve, Honeywell Millivolt
 - 807-1603 Natural Gas
 - 807-1604 Propane Gas
- 14 810-0691 Vent Tube, Gas Valve
- 15 810-0703 Gas Line, 0.25-inch x 17.50-inch
- 16 813-0154 Plug, Gas Pressure Test Port
- 17 Pilot Assembly (Does not include thermopile.)
 - 812-1286 Natural Gas
 - 812-1287 Propane Gas
- 18 810-1873 Thermopile, Double-Lead with Push-on Terminals
 - * 810-0159 Thermopile, Double-Lead with Forked Terminals
- 19 810-0617 Thermopile, Single Screw-in Lead with Standard-size Barrel
 - * 810-0162 Thermopile, Screw-in with Small Barrel
(also requires adapter 810-0425)
- 21 807-1906 Element, Piezo Igniter (Trigger is Part Number 810-1001)
- 22 810-1173 Gas Line, 0.25-inch x 8.5-inch

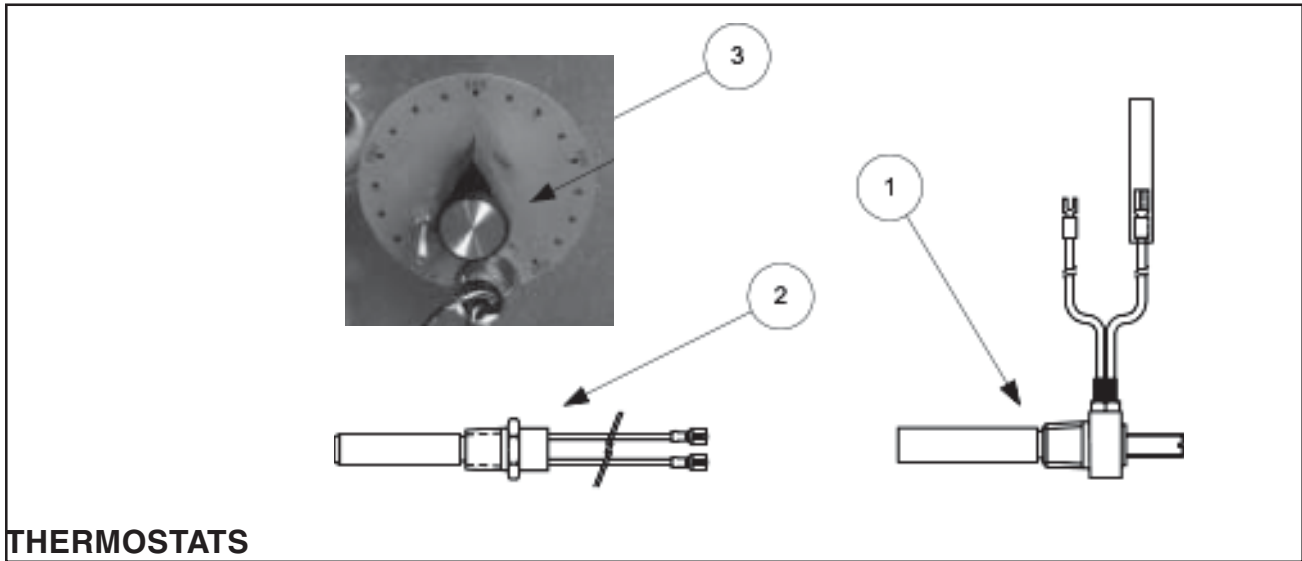

THERMOSTATS

Item	Part#	Component
1	807-0099	Thermostat 3 Fenwal 17102
2	826-1177	Thermostat, 425 Degree Hi-Limit Thermostat Service Kit
3	806-0087	Thermostat Dial Plate and Stop Assembly, MJ35
*	900-0031	Plug Button
*	807-0123	Heyco Bushing
*	809-0089	Screw, Dial Plate

* Not Illustrated

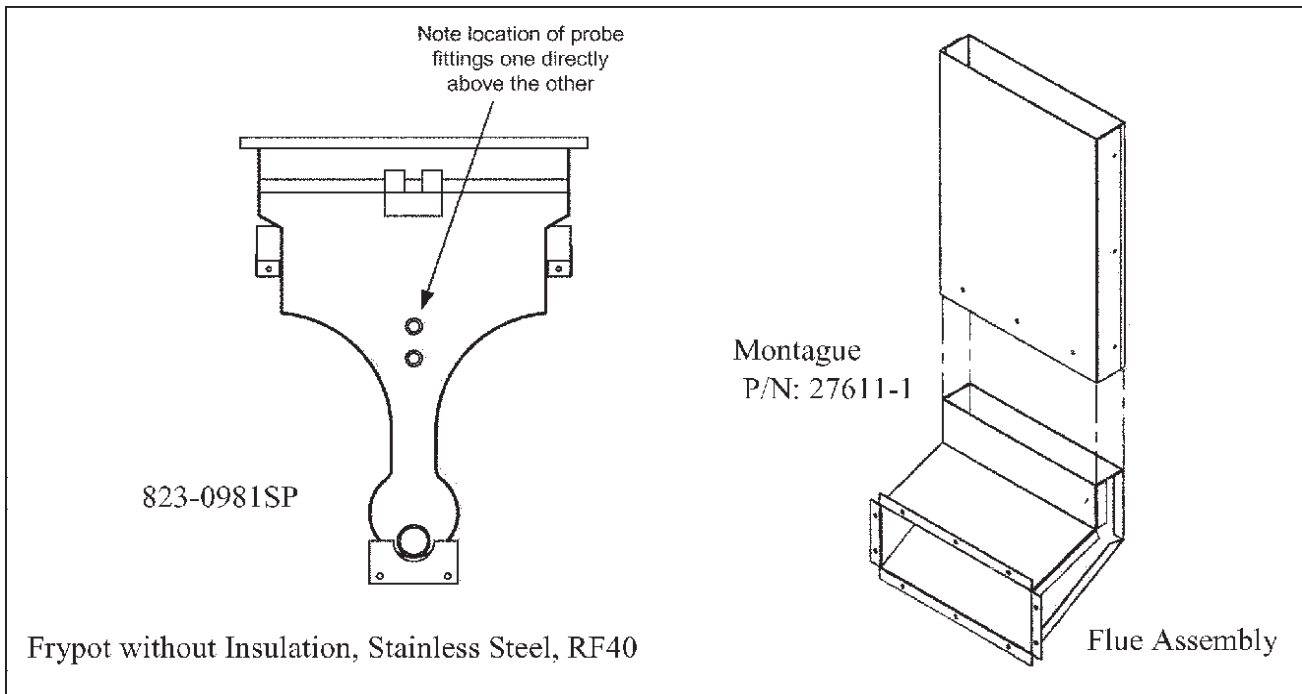

823-0981SP

Montague
P/N: 27611-1

Flue Assembly

Frypot without Insulation, Stainless Steel, RF40

WARNING

If not installed, operated and maintained in accordance with the manufacturer's instructions, this product could expose you to substances in fuel or in fuel combustion which can cause death or serious illness and which are known to the State of California to cause cancer, birth defects or other reproductive harm.

The State of California enacted the California Safe Drinking Water and Toxic Enforcement Act of 1986, (Prop. 65), which "prohibits any person in the course of doing business from knowingly and intentionally exposing any individual to a chemical known to the State of California to cause cancer or reproductive toxicity without first giving clear and reasonable warning to such individuals." The Governor's Scientific Advisory Panel added carbon monoxide to the list of hazardous chemicals known to cause reproductive harm.

In order to establish full compliance with Proposition 65, we attached a yellow warning label to each gas fired unit manufactured by the Montague Company.

Carbon monoxide would not be present in concentrations that would pose a "significant risk" to the consumer when the equipment is installed, operated and maintained as follows:

1. Installed in accordance with all local codes, or in the absence of local codes, with the current National Fuel Gas Code Z223.1.
2. Installed under a properly designed and operating exhaust hood.
3. Connected to the type of gas for which the unit is equipped.
4. Proper appliance pressure regulator installed on the gas supply line and adjusted for the manifold pressure marked on the rating plate.
5. Adequate air supply to the unit.
6. The equipment is operated in the manner intended using the proper utensil for that type of appliance.
7. Keep the equipment clean and have it checked periodically.
8. Burner air adjustments, mechanical maintenance and repairs should be performed by qualified service personnel.

If the equipment is not installed, operated and maintained in accordance with the above, concentrations of carbon monoxide in excess of the established limits could present in the kitchen environment.

ALL PERSONNEL IN THE WORKPLACE WHO MAY BE SUBJECT TO ANY EXPOSURE OF CARBON MONOXIDE MUST BE WARNED OF SUCH POSSIBLE EXPOSURE. THIS WARNING SHOULD BE CONVEYED IN A MANNER SO THAT IT IS CLEARLY UNDERSTOOD BY THE EMPLOYEE, AND THE EMPLOYEE SHOULD BE ASKED IF IN FACT HE OR SHE UNDERSTANDS THE CORRECT METHOD OF OPERATION OF THE EQUIPMENT AND THAT A RISK OF EXPOSURE EXISTS IF THE EQUIPMENT IS OPERATED IMPROPERLY.



THE MONTAGUE COMPANY

1830 Stearman Avenue, P.O. Box 4954, Hayward, CA 94540-4954

IMPORTANT

When ordering parts, to eliminate mistakes and facilitate delivery, always give the following information:

Serial No. _____

Model No. _____

Change No. _____

Name & No. of Part

<u>Model No.</u>	<u>Change No.</u>	<u>Serial No.</u>	
<input type="text"/>	<input type="text"/>	<input type="text"/>	<input type="text"/>

The Montague Company
1830 Stearman Avenue
P.O. Box 4954
Hayward, CA 94540-4954

P/N 14557-2 Rev.B 6/03