

INSTRUCTION MANUAL

MONTAGUE EXTREME CUISINE

Custom Refrigerated Equipment Bases

**MODELS:
RB Series**

**These instructions should be read thoroughly before attempting installation.
Set up and installation should be performed by qualified installation personnel.**

Keep area around appliances free and clear from combustibles.

**PLEASE RETAIN THIS MANUAL
FOR FUTURE REFERENCE.**



THE MONTAGUE COMPANY
1830 Stearman Avenue P.O. BOX 4954
HAYWARD, CA 94540-4954
TEL: 510/785-8822 FAX: 510/785-3342

CONTENTS

INTRODUCTION	4	SERVICE DIAGNOSIS.....	11
SPECIFICATIONS	5	WIRING DIAGRAM	14
INSTALLATION.....	6	WARRANTY.....	15
OPERATION.....	8	SERVICE RECORD	17
MAINTENANCE.....	9		

IMPORTANT

WARNING:

Improper installation, adjustment, alteration, service or maintenance can cause property damage, injury or death. Read the operating and maintenance instructions thoroughly before installing or servicing this equipment.

FOR YOUR SAFETY:

Do not store or use gasoline or other flammable vapors and liquids in the vicinity of this or any other appliance.

INSTRUCTIONS TO BE FOLLOWED IN THE EVENT THE USER SMELLS GAS MUST BE POSTED IN A PROMINENT LOCATION. THIS INFORMATION MAY BE OBTAINED BY CONSULTING THE LOCAL GAS SUPPLIER.

SHIPPING DAMAGE CLAIM PROCEDURE

For your protection, please note that equipment in this shipment was carefully inspected and packed by skilled personnel before leaving the factory. The transportation company assumes full responsibility for safe delivery upon acceptance of this shipment.

If shipment arrives damaged:

1. **VISIBLE LOSS OR DAMAGE**—Be certain this is noted on freight bill or express receipt, and signed by person making delivery.
2. **FILE CLAIM FOR DAMAGES IMMEDIATELY**—Regardless of the extent of damage.
3. **CONCEALED LOSS OR DAMAGE**—If damage is unnoticed until merchandise is unpacked, notify transportation company or carrier immediately, and file “concealed damage” claim with them. This should be done within fifteen (15) days of date that delivery was made to you. Be sure to retain container for inspection.

We cannot assume responsibility for damage incurred in transit. We will, however, be glad to furnish you with necessary documents to support your claim.

TABLE OF CONTENTS

INTRODUCTION	
Description of Under Counter Refrigerators	4
Features of Under Counter System	4
Condensing Unit	4
Refrigerant	4
Electrical Characteristics	4
Standard Components	4
Factory Installed Accessories	4
REFRIGERATION SYSTEM SPECIFICATION	5
INSTALLATION	6
Receipt and Inspection of Equipment	6
Location	6
Leveling	6
Plumbing	7
Electrical Connection	7
OPERATION	8
MAINTENANCE	9
Electrical and Piping Connections	9
Care and Cleaning	9
Cleaning the Cabinet	9
Cleaning the Condenser	9
Cleaning the Gaskets	9
Cleaning Drawer Slides	9
Preventing Blower Coil Corrosion	9
Unit Cooler	10
SERVICE DIAGNOSIS	11
Condensing Units	11
WIRING DIAGRAM	14
STANDARD WARRANTY	15
SERVICE RECORD	17

DESCRIPTION OF UNDER COUNTER REFRIGERATORS

The E.S.P. Self Contained air cooled Under Counter Refrigeration System utilizes safe CFC's and offers tremendous operating efficiency by using an over sized system. This high operating efficiency is made through effective use of the condenser coil surface area. The condenser coils on our units are almost 20% bigger than conventional competitive designs. Complete factory assembly eliminates on-sight construction competitive designs. Complete factory assembly eliminated on-sight construction costs of built-up systems by refrigeration technicians and electricians in the field. The Under Counter System is designed primarily for institutional food service operations including hospitals, universities, schools, hotels, restaurant, coffee shops, and convenience stores.

Under Counter System pulls fresh air over the compressor bodies to reduce their operating temperature. Compressor ventilation has become increasingly important because of regulations effecting the use of R-22 refrigerant.

FEATURES OF UNDER COUNTER SYSTEM

Condensing Unit

A refrigeration condensing unit is a highly sophisticated apparatus. It is with the anticipation that it will provide many years of trouble-free operation with minimal maintenance. Usually the length of service life realized from a particular condensing unit is directly proportional to the care with which the original installation was performed. The correct electrical supply must be provided to the condensing unit. The voltage at the motor-compressor terminals should be checked during start-up and units operation under full load to insure a tolerance of plus or minus 10 percent of the name-plate rating.

Refrigerant

R-22 is used for the Under Counter System.

Electrical Characteristics

Each unit is equipped with 120 Volts. 1 Phase. 60 Hertz power supply.

Standard Components

Each unit consists of hermetic compressors, condenser with heavy duty fan motors, oversized receivers, factory installed accessories, unit coolers with T-stat solenoid valve, TX valve and suction line P-Trap.

Factory Installed Accessories

Drier, sight glass, and pressure control.

The E.S.P. Under Counter Systems are tested and assembled under strict quality assurance procedures. Each unit is tested and charged with R-22 before shipment.

REFRIGERATION SYSTEM SPECIFICATIONS

All units are 115 volts, 60 hertz, single phase

Self-Contained Units			Remote Units					
Length	R-22 H.P.	R-22 AMPS	R-22 NEMA PLUG	Length	H.P.	EVAP BTU	BTU LOAD	COIL AMPS
<u>Salad Tables:</u>								
36" to 66"	1/4	8.0	5-15P	24" to 54"	1/4*	160	484-1020	3.0
72" to 84"	1/3	12.0	5-15P	60" to 84"	1/3*	320	1111-1478	6.0
96" to 102"	1/3	12.0	5-15P	90" to 96"	1/2*	320	1570-1661	6.0
108" to 114"	1/2	14.0	5-20P					
<u>Work Top Tables:</u>								
36" to 66"	1/4	8.0	5-15P	24" to 54"	1/4*	160	367-825	3.0
72" to 84"	1/3	12.0	5-15P	60" to 84"	1/3*	320	917-1183	6.0
96" to 102"	1/3	12.0	5-15P	90" to 96"	1/2*	320	1375-1466	6.0
108" to 114"	1/2	14.0	5-20P					
<u>Pizza/Sandwich Tables:</u>								
60" to 66"	1/4	8.0	5-15P	48"	1/4*	160	1424	3.0
84" to 90"	1/2	14.0	5-15P	72"	1/2*	320	2135	6.0
114" to 120"	3/4	16.0	5-20P	96"	3/4*	320	2705	6.0
<u>Pizza/Sandwich Tables:</u>								
66" to 72"	1/3	12.0	5-15P	54"	1/3*	160	1716	3.0
93" to 99"	1/2	14.0	5-20P	81"	1/2*	320	2574	6.0
<u>Baker's Tables:</u>								
66" to 72"	1/4	8.0	5-15P	54"	1/3*	160	1053	3.0
93" to 99"	1/3	12.0	5-15P	81"	1/3*	320	1580	6.0

INSTALLATION

RECEIPT AND INSPECTION OF EQUIPMENT

Inspect Under Counter unit and all accessories shipped for any damage or shortages. Any damage or shortages should be reported immediately to the delivering carrier. Damaged material becomes the delivering carrier's responsibility and it should not be returned to the manufacturer without prior approval. Do not remove any shipping material until the unit is installed in its permanent location.

LOCATION

Be sure the location chosen has a floor strong enough to support the total weight of the cabinet and contents. A fully loaded 72" long model may weight as much as 3000 pounds! Reinforce the floor as necessary to provide for maximum loading.

For the most efficient refrigeration, be sure to provide good air circulation inside and out.

Inside cabinet: Do not pack refrigerator so full that air cannot circulate.

Outside cabinet: Be sure that the unit has access to ample air. Avoid hot corners and locations near stoves and ovens.

It is recommended that the unit be installed no closer than 1 inch from any wall. Do not install the unit near any combustible material or object affected by heat or moisture.

LEVELING

A level cabinet looks better and will perform better because:

1. The drain pan will drain properly.
2. The doors will line up with the frames properly.
3. The cabinet will not be subject to undue strain.

Some models have casters for your convenience, for ease of cleaning underneath and for mobility. It is important that the unit be installed in a stable condition with the front casters locked before operating, however.

PLUMBING

Self-contained models are standard with a condensate evaporator. If, for some reason, a unit does not have a condensate evaporator, or the evaporator fails, the unit's drain line must have an outlet to an appropriate drainage area or container.

Moisture collecting from improper drainage can create a slippery surface on the floor and a hazard to employees. It is the owner's and operator's responsibility to provide a container for or outlet for drainage.

ELECTRICAL CONNECTION

Refer to the amperage data on page 3, the serial tag, your local code or the National Electrical Code to be sure the unit is connected to the proper power source. A protected circuit of the correct voltage and amperage must be run for connection of the line cord, or permanent connection to the unit.

Self-contained unit with cord and plug have an ON/OFF switch located directly behind the louvered panel covering the compressor section. Simply turn the switch to ON to begin operation.

The power switch should be turned to OFF and the unit disconnected from the power source whenever performing service or maintenance functions.

Never operate the unit without the louvered panel in place!

If electrical receptacles are to be mounted in the unit's backsplash, they must be wired independently from the existing unit wiring.

OPERATION

After turning the ON/OFF switch to ON, the unit's compressor will begin operating. E.S.P. Under Counter Refrigerators are designed to maintain an operational temperature of 36°F to 40°F.

Overloading the storage area, restricting the air flow, and continuous opening and closing of the doors and drawers will hamper the unit's ability to maintain operational temperatures.

MAINTENANCE

ELECTRICAL AND PIPING CONNECTIONS

All electrical connections should be periodically checked to be sure they are tight. Loose connections contribute to low voltage conditions which can cause motor failure.

Refrigerant connections should be inspected to insure that they have not loosened. Whenever it is necessary to add refrigerant, a careful leak check of all refrigerant connections should be made.

CARE AND CLEANING

Cleaning the cabinet

The interior and exterior can be cleaned using soap and warm water. If this is not sufficient, try ammonia and water or a non-abrasive liquid cleaner. When cleaning the exterior, always rub with the "grain" of the stainless steel to avoid marring the finish. Do not use an abrasive cleaner because it will scratch the stainless steel.

Cleaning the condenser

In order to maintain proper refrigeration performance, the condenser fins must be cleaned of dust, dirt, and grease regularly. It is recommended that this be done at least every three months. If conditions are such that the condenser is totally blocked in three months, the frequency of cleaning should be increased. Clean the condenser with a vacuum cleaner or stiff brush. If extremely dirty, a commercially available condenser may be required.

Cleaning gaskets

Door gaskets should be cleaned as required to maintain their ability to seal properly. Do not use sharp tools or knives to scrape the bellows as this may tear the gaskets and eliminate its ability to seal. A bristle brush and solution of soap and water should be all that is required to keep the gasket clean. Do not use full strength degreasing agents on the gasket because they could cause the gasket to crack and become brittle.

Cleaning drawer slides

Drawer slides should be kept clean and free of food. The slides should be greased as needed with a "food-zone" approved lubricant.

Preventing blower coil corrosion

To help prevent corrosion of the blower coil, store all acidic items, such as pickles, in sealable containers. Immediately wipe up all spills of items that are either acids or bases.

PRESSURE CONTROL SETTINGS

Factory recommended low-pressure control settings are:

R-22 refrigerators: 68# cut-in and 38# cut out to maintain

approximate interior temperature of 38°F.

Factory recommended high-pressure settings are:

1/2 and 3/4 horsepower units: 450# for manual reset.

UNIT COOLER

Unit cooler should be checked at least once a month for proper defrosting to maintain amount and pattern of frosting. It is dependent on the temperature of the room, the type of product being stored, how often new product is brought into the room and the percentage of time the door is open. Also, if the coil is not defrosting completely, check for faulty defrost heaters.

Under normal usage, maintenance should cover the following items at least once every six months.

1. Tighten all electrical connections.
2. Tighten fan set screws.
3. Clean the coil surface.
4. Check the operation of the control system.
5. Clean the drain pan and check for proper drainage.
6. Check the drain line heaters.

SERVICE DIAGNOSIS—CONDENSING UNITS

SYMPTOM	CAUSE	REMEDY
A. Compressor does not run.	<ol style="list-style-type: none"> 1. Motor line open. 2. Fuse blown. 3. Tripped overload. 4. Control contacts dirty or jammed in open position. 5. Piston seized. 6. Frozen compressor or motor bearings. 7. Control in off position because of cold location. 8. Defective starting component (single phase compressor only.) 	<ol style="list-style-type: none"> 1. Close start or disconnect switch. 2. Replace fuse. 3. See part C. 4. Repair or replace. 5. Remove motor compressor head. Look for broken valve and jammed parts. 6. Repair or replace. 7. Use thermostatic control or move control to warmer location. 8. Locate and replace.
B. Unit short cycles	<ol style="list-style-type: none"> 1. Control differential set too closely. 2. Discharge valve leaking. 3. Motor-compressor overload. 4. Refrigerant shortage. 5. Refrigerant overcharge. 6. Cycling on high pressure. 	<ol style="list-style-type: none"> 1. Widen differential. 2. Correct condition. 3. Check for high head pressure, tight bearings, seized, pistons, clogged air cooled condenser. 4. Repair leak and recharge. 5. Purge. 6. Check water supply, dirty condenser or defective fan.
C. Compressor will not start—hums intermittently (cycling on overhead) .	<ol style="list-style-type: none"> 1. Improperly wired. 2. Low line voltage. 3. Relay contacts not closing. 4. Open circuit in starting winding. 5. Stator winding grounded. 6. High discharge pressure. 7. Tight compressor. 	<ol style="list-style-type: none"> 1. Check wiring against diagram. 2. Checks main line voltage and determine location of voltage and drops. 3. Checks by operating manually. Replace replay if defective. 4. Check stator leads. If leads are OK, replace stator. 5. Check stator leads. If leads are OK, replace stator. 6. Eliminate cause of excessive pressure. Make sure discharge shut-off valve is open. 7. Check oil level; correct binding.
D. Unit operates long or continuously.	<ol style="list-style-type: none"> 1. Refrigerant shortage. 2. Control contacts sticking closed position. 3. Dirty condenser. 4. Air in system. 5. Compressor inefficient. 6. Improper wiring. 	<ol style="list-style-type: none"> 1. Repair leak and recharge. 2. Clean points or replace control. 3. Clean condenser. 4. Purge. 5. Check valves and piston. 6. Check wiring and correct if necessary.
E. Fixture temperature too high.	<ol style="list-style-type: none"> 1. Refrigerant shortage 2. Control set too high. 3. Control wiring loose. 4. Expansion valve or strainer plugged. 5. Compressor inefficient. 6. Expansion valve set too high. 7. Iced or dirty coil. 8. Unit too small. 9. Clogged or small gas lines. 10. Oil logged system. 	<ol style="list-style-type: none"> 1. Repair leak and recharge. 2. Reset control. 3. Check wiring to control. 4. Clean or replace. 5. Check valves and pistons. 6. Lower settings. 7. Defrost or clean. 8. Add unit or replace. 9. Clear clogging or increase line size. 10. Remove excess oil, check refrigerant. Charge.

SERVICE DIAGNOSIS—CONDENSING UNITS

SYMPTOM	CAUSE	REMEDY
F. Head pressure too high.	<ol style="list-style-type: none"> 1. Refrigerant overcharge. 2. Air in system. 3. Dirty air-cooled condenser. 4. Insufficient water supply. 5. Recirculating cooling air. 6. High side restriction. 7. Head pressure control valve set wrong. 	<ol style="list-style-type: none"> 1. Purge. 2. Purge. 3. Clean area around air-cooled condenser and inspect for airborne dirt source. 4. Check water valves and inspect cooler. 5. Seal off unit from other machines and provide intake isolated from air outlet. 6. Remove blockage. 7. Readjust.
G. Head pressure too low.	<ol style="list-style-type: none"> 1. Refrigerant shortage. 2. Compressor suction or discharge valves inefficient. 3. Cold ambient or cold water. 4. Head pressure control valve set wrong or no heads pressure valve instead. 	<ol style="list-style-type: none"> 1. Repair leak and recharge. 2. Clean or replace leaky valve plates. 3. No remedy, as efficiency is increased. However, if condensing temperature is below 85°, expansion valve will not be able to feed properly and some form of head pressure control must be provided, 4. Readjust or install a head pressure control valve.
H. Noisy Unit	<ol style="list-style-type: none"> 1. Insufficient compressor oil. 2. Tubing rattle. 3. Mounting loose. 4. Oil slugging or refrigerant flood back. 5. Unbalanced fan or defective fan motor. 	<ol style="list-style-type: none"> 1. Repair leak and recharge. 2. Bend tubes away from contact. 3. Tighten. 4. Adjust oil level or refrigerant change. Check expansion valve for leak or oversized orifice. 5. Replace bent or broken fan blades. Check motor bearings.
I. Compressor loses oil.	<ol style="list-style-type: none"> 1. Short of refrigerant. 2. Gas-oil ratio low. 3. Plugged expansion valve or strainer. 4. Oil trapping in lines. 5. Short cycling. 6. Superheat too high at compressor suction. 	<ol style="list-style-type: none"> 1. Repair leak and recharge. 2. Add 1pt. oil for each 10lbs. of refrigerant added to factory charge. 3. Clean or replace. 4. Drain tubing toward compressor. 5. Refer to Part B. 6. Change location of expansion valve bulb or adjust valve to return wet gas to compressor.
J. Frosted or sweating suction line.	<ol style="list-style-type: none"> 1. Expansion valve admitting excess refrigerant. 	<ol style="list-style-type: none"> 1. Adjust expansion valve.
K. Hot liquid line.	<ol style="list-style-type: none"> 1. Shortage of refrigerant. 2. Expansion valve open too wide. 	<ol style="list-style-type: none"> 3. Repair leak and recharge. 4. Adjust expansion valve.

SERVICE DIAGNOSIS—CONDENSING UNITS

SYMPTOM	CAUSE	REMEDY
L. Frosted liquid line.	<ol style="list-style-type: none"> 1. Receiver shut-off valve partially closed or restricted. 2. Clogged dehydrator. 	<ol style="list-style-type: none"> 1. Open valve or remove. 2. Replace clogged part.
M. Unit on vacuum.	<ol style="list-style-type: none"> 1. Ice plugging expansion. 2. Plugged expansion valve. 	<ol style="list-style-type: none"> 1. Apply hot wet cloth to expansion valve. If suction pressure now increases, there is moisture in the system and a dryer should be installed in the line. 2. Clean strainer or replace expansion valve.
N. Motor overloads relays or circuit breaker open.	<ol style="list-style-type: none"> 1. Low voltage during high load conditions. 2. Defective or grounded wiring in motor or power circuits. 3. Loose power wiring. 4. High condensing temperature. 5. Power line fault causing unbalanced voltage. 6. High ambient temperature around the overload relay. 7. Failure of second starter to pull in on winding system. 	<ol style="list-style-type: none"> 1. Check supply voltage for excessive line drop. 2. Replace compressor motor. 3. Check all connection and tighten. 4. See corrective steps for high discharge pressure. 5. Check supply voltage. Notify power company. Do not start until fault is corrected. 6. Provided ventilation to reduce heat. 7. Repair or replace starter or time delay mechanism.

WIRING DIAGRAM-REFRIGERATED WORK TABLES

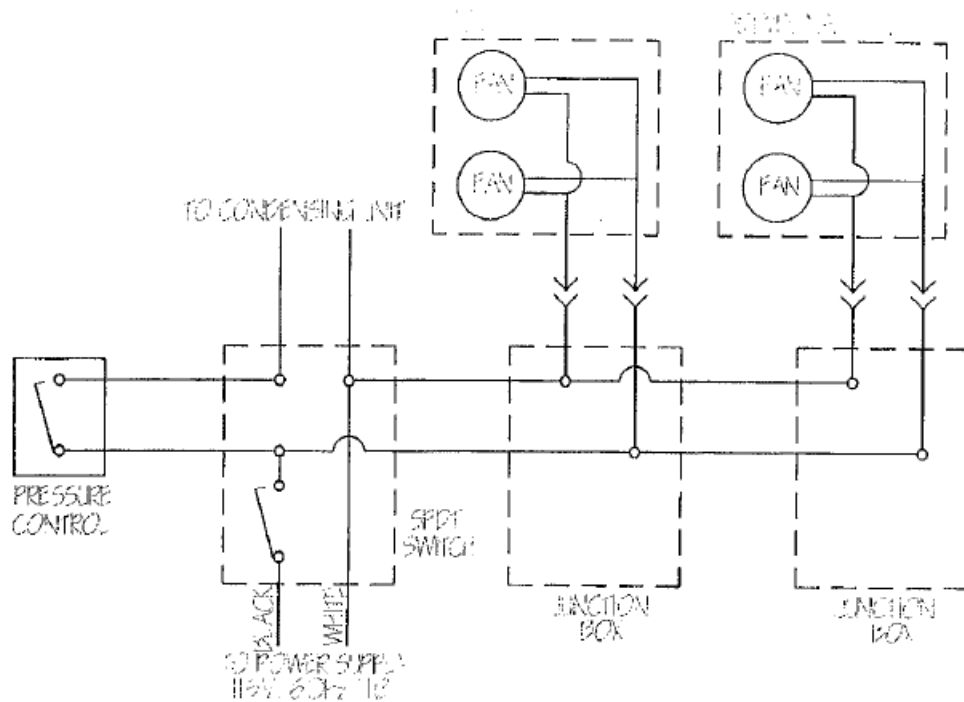

WIRING DIAGRAM—FREEZER BASES

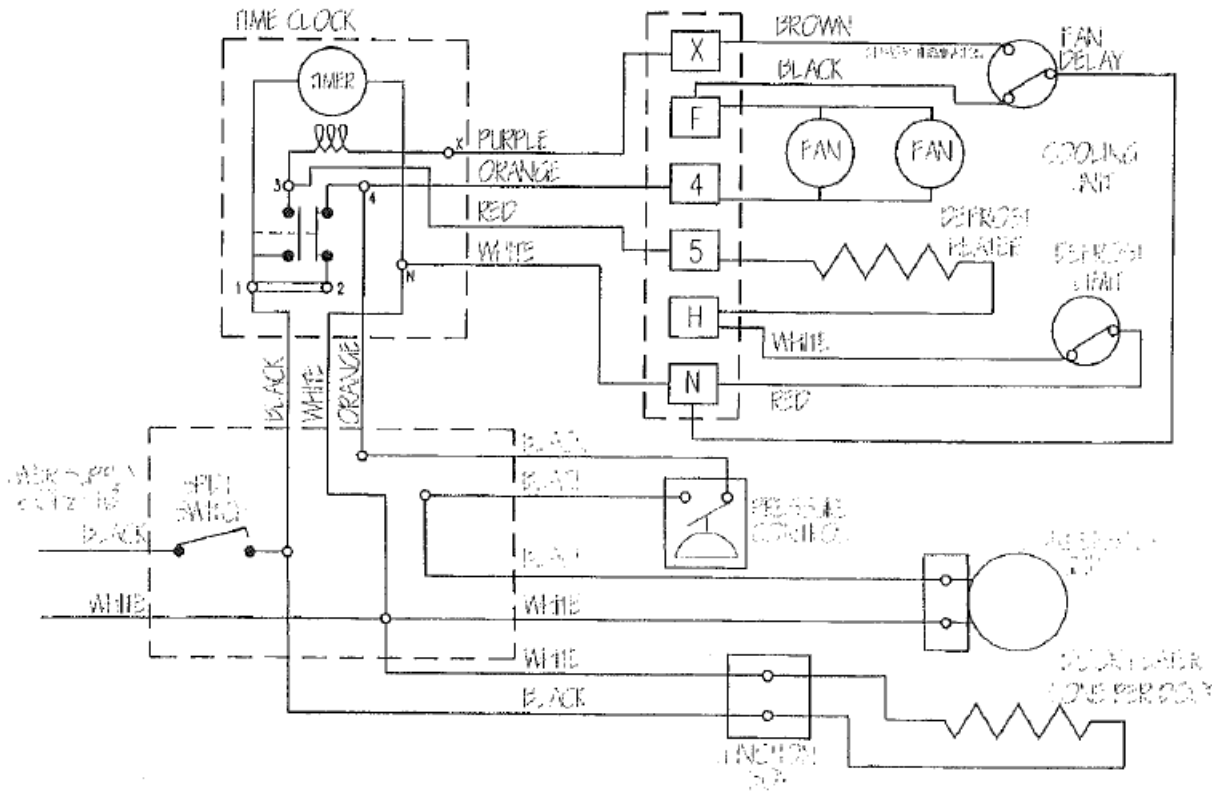

OMNI BAR EQUIPMENT
 9300 HALL ROAD, DOWNEY, CA. 90241
 P (562) 861-8430 * (562) 861-2152 * FAX (562) 822-5080

STANDARD WARRANTY – ONE YEAR PARTS, 90 DAYS LABOR

E.S.P. 2000, Inc. warrants to the original purchaser of every new refrigerated unit that such unit, and all parts thereof, will be free from defects in material and workmanship under normal use and service for a period of one year from the shipping date of the unit to such original purchaser. During this one year warranty period, E.S.P. will repair or replace any defective part or portion thereof if sent to E.S.P. by the original purchaser which E.S.P. determines was defective due to faulty material or workmanship. The original purchaser will pay all labor (except during the first 90 days from the shipping date of the unit), crating, freight and related costs incurred in the removal of the unit and shipment to E.S.P. E.S.P. will pay the return costs if the unit or part thereof was defective.

The term "original purchaser" as used herein means that person, firm, association, or corporation for whom the equipment was originally installed.

The warranty does not apply to any material that has been subjected to misuse, neglect, alteration, or accident, such as accidental damage to the exterior finish, and to any refrigerated unit or part thereof, which has been repaired or altered by other than E.S.P. in any way so as in our judgment to affect its quality or efficiency. This warranty also does not cover the refrigerator drier or the light bulbs used in the refrigerator. The warranty is subject to the user's normal responsibility, such as cleaning the condenser coil and is in lieu of all other obligations of E.S.P. E.S.P. expressly disclaims all other warranties, whether written or oral, express or implied, including any warranty of performance, merchantability, or fitness for a particular purpose. This warranty supersedes and excludes any prior oral or written representations or warranties. We neither assume, nor authorize any other person to assume for us, any other liability in connection with our products.

Removal or defacement of the original Serial Number or Model Number from any refrigerated unit shall be deemed to release us from all obligations hereunder or any other obligations, express or implied.

Parts furnished by suppliers to E.S.P. are guaranteed by E.S.P. only to the extent of the original manufacturer's express warranty to E.S.P.

Failure of the purchaser to receive such manufacturer's warranty shall in no way create any warranty, express or implied, or any other obligation or liability on our part in respect thereof.

If shipment of a replacement part is requested prior to the arrival in E.S.P. factory of the part claimed to be defective, the customer must accept delivery of the replacement part on a C.O.D. basis, with credit being issued when the defective part has been received and inspected at our plant and proved to be within this warranty.

The warranty under no conditions gives the right to the purchaser-user to replace the defective unit with a complete unit of the same manufacturer or of another make. It further does not permit the replacement to be made with a motor compressor assembly or another kind unless authorized by us in writing.

No claims can be made against the warranty for spoilage of products on account of refrigeration failure.

Performance by us under this warranty is not contingent upon causes beyond our control, and we shall not be liable for any default or delay in performance there under caused by any contingency beyond our control, including war, governmental restrictions or restraints, strikes, fire, floods, acts of nature, short or reduced supply of raw materials, or discontinuance of the parts by the original part manufacturer.

The sole and exclusive remedies of the original purchaser and the full liability of E.S.P. for any breach of this warranty will be as provided in this warranty.

In no event will E.S.P. be liable for special, incidental or consequential damages, or for damages in the nature of penalties.

OMNI

9300 HALL ROAD, DOWNEY, CA 90241
Phone (562) 861-6430 Fax (562) 622-5680
E-Mail: omnibarequip@aol.com

WARNING

If not installed, operated and maintained in accordance with the manufacturer's instructions, this product could expose you to substances in fuel or in fuel combustion which can cause death or serious illness and which are known to the State of California to cause cancer, birth defects or other reproductive harm.

The State of California enacted the California Safe Drinking Water and Toxic Enforcement Act of 1986, (Prop. 65), which "prohibits any person in the course of doing business from knowingly and intentionally exposing any individual to a chemical known to the State of California to cause cancer or reproductive toxicity without first giving clear and reasonable warning to such individuals." The Governor's Scientific Advisory Panel added carbon monoxide to the list of hazardous chemicals known to cause reproductive harm.

In order to establish full compliance with Proposition 65, we attached a yellow warning label to each gas fired unit manufactured by the Montague Company.

Carbon monoxide would not be present in concentrations that would pose a "significant risk" to the consumer when the equipment is installed, operated and maintained as follows:

1. Installed in accordance with all local codes, or in the absence of local codes, with the current National Fuel Gas Code Z223.1.
2. Installed under a properly designed and operating exhaust hood.
3. Connected to the type of gas for which the unit is equipped.
4. Proper appliance pressure regulator installed on the gas supply line and adjusted for the manifold pressure marked on the rating plate.
5. Adequate air supply to the unit.
6. The equipment is operated in the manner intended using the proper utensil for that type of appliance.
7. Keep the equipment clean and have it checked periodically.
8. Burner air adjustments, mechanical maintenance and repairs should be performed by qualified service personnel.

If the equipment is not installed, operated and maintained in accordance with the above, concentrations of carbon monoxide in excess of the established limits could present in the kitchen environment.

ALL PERSONNEL IN THE WORKPLACE WHO MAY BE SUBJECT TO ANY EXPOSURE OF CARBON MONOXIDE MUST BE WARNED OF SUCH POSSIBLE EXPOSURE. THIS WARNING SHOULD BE CONVEYED IN A MANNER SO THAT IT IS CLEARLY UNDERSTOOD BY THE EMPLOYEE, AND THE EMPLOYEE SHOULD BE ASKED IF IN FACT HE OR SHE UNDERSTANDS THE CORRECT METHOD OF OPERATION OF THE EQUIPMENT AND THAT A RISK OF EXPOSURE EXISTS IF THE EQUIPMENT IS OPERATED IMPROPERLY.



The MONTAGUE COMPANY

1830 Stearman Avenue, P.O. Box 4954 Hayward, CA 94540-4954

IMPORTANT

When ordering parts, to eliminate mistakes and facilitate delivery, always give the following information:

Serial No. _____

Model No. _____

Change No. _____

Name & No. of Part

Model No. Change No. Serial No.

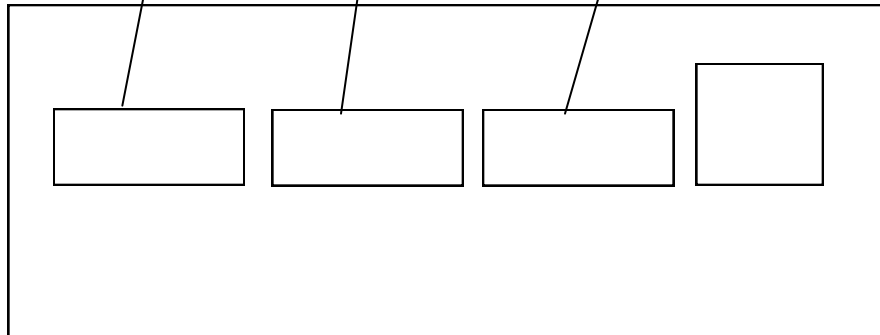

REFRIGERATED BASE ID NAME PLATE

The Montague Company
1830 Stearman Avenue
P.O. Box 4954
Hayward, CA 94540-4954

P/N 7055-6 2/02