

TECHNICAL & SERVICE MANUAL

Series PVFY Vertical Concealed Indoor Unit

<Indoor unit>

Models **PVFY-P12E00A, PVFY-P18E00A**
PVFY-P24E00A, PVFY-P30E00A
PVFY-P36E00A, PVFY-P48E00A
PVFY-P54E00A



CONTENTS

SAFETY PRECAUTIONS	1
1. FEATURES.....	3
2. PART NAMES AND FUNCTIONS	4
3. SPECIFICATION	6
4. OUTLINES AND DIMENSIONS.....	8
5. WIRING DIAGRAM	11
6. REFRIGERANT SYSTEM DIAGRAM....	12
7. TROUBLESHOOTING	13



For use with R410A only

SAFETY PRECAUTIONS

1. Before installation and electric work

- s Before installing the unit, make sure you read all the “Safety precautions”.
- s The “Safety precautions” provide very important points regarding safety. Make sure you follow them.
- s This equipment may not be applicable to EN61000-3-2: 1995 and EN61000-3-3: 1995.
- s This equipment may have an adverse effect equipment on the same electrical supply system.
- s Please report to or take consent by the supply authority before connection to the system.

Symbols used in the text

Warning:

Describes precautions that should be observed to prevent danger of injury or death to the user.

Caution:

Describes precautions that should be observed to prevent damage to the unit.

Symbols used in the illustrations

 : Indicates an action that must be avoided.

 : Indicates that important instructions must be followed.

 : Indicates a part which must be grounded.

 : Indicates that caution should be taken with rotating parts. (This symbol is displayed on the main unit label.) <Color: Yellow>

 : Beware of electric shock (This symbol is displayed on the main unit label.) <Color: Yellow>

 **Warning:**
Carefully read the labels affixed to the main unit.

Warning:

- **Ask the dealer or an authorized technician to install the air conditioner.**
 - Improper installation by the user may result in water leakage, electric shock, or fire.
- **Install the air unit at a place that can withstand its weight.**
 - Inadequate strength may cause the unit to fall down, resulting in injuries.
- **Use the specified cables for wiring. Make the connections securely so that the outside force of the cable is not applied to the terminals.**
 - Inadequate connection and fastening may generate heat and cause a fire.
- **Prepare for typhoons and other strong winds and earthquakes and install the unit at the specified place.**
 - Improper installation may cause the unit to topple and result in injury.
- **Always use an air cleaner, humidifier, electric heater, and other accessories specified by Mitsubishi Electric.**
 - Ask an authorized technician to install the accessories. Improper installation by the user may result in water leakage, electric shock, or fire.

- **Never repair the unit. If the air conditioner must be repaired, consult the dealer.**
 - If the unit is repaired improperly, water leakage, electric shock, or fire may result.
- **Do not touch the heat exchanger fins.**
 - Improper handling may result in injury.
- **When handling this product, always wear protective equipment. EG : Gloves, full arm protection namely boiler suit, and safety glasses.**
 - Improper handling may result in injury.
- **If refrigerant gas leaks during installation work, ventilate the room.**
 - If the refrigerant gas comes into contact with a flame, poisonous gases will be released.
- **Install the air conditioner according to this Installation Manual.**
 - If the unit is installed improperly, water leakage, electric shock, or fire may result.
- **Have all electric work done by a licensed electrician according to “Electric Facility Engineering Standard” and “Interior Wire Regulations” and the instructions given in this manual and always use a special circuit.**
 - If the power source capacity is inadequate or electric work is performed improperly, electric shock and fire may result.
- **Securely install the cover of control box and the panel.**
 - If the cover and panel are not installed properly, dust or water may enter the outdoor unit and fire or electric shock may result.
- **When installing and moving the air conditioner to another site, do not charge the it with a refrigerant different from the refrigerant (R410A) specified on the unit.**
 - If a different refrigerant or air is mixed with the original refrigerant, the refrigerant cycle may malfunction and the unit may be damaged.
- **If the air conditioner is installed in a small room, measures must be taken to prevent the refrigerant concentration from exceeding the safety limit even if the refrigerant should leak.**
 - Consult the dealer regarding the appropriate measures to prevent the safety limit from being exceeded. Should the refrigerant leak and cause the safety limit to be exceeded, hazards due to lack of oxygen in the room could result.
- **When moving and reinstalling the air conditioner, consult the dealer or an authorized technician.**
 - If the air conditioner is installed improperly, water leakage, electric shock, or fire may result.
- **After completing installation work, make sure that refrigerant gas is not leaking.**
 - If the refrigerant gas leaks and is exposed to a fan heater, stove, oven, or other heat source, it may generate noxious gases.
- **Do not reconstruct or change the settings of the protection devices.**
 - If the pressure switch, thermal switch, or other protection device is shorted and operated forcibly, or parts other than those specified by Mitsubishi Electric are used, fire or explosion may result.

⚠ Warning:

- **Note the following when building a heater in the air conditioning system.**
 - Leave enough space between units for proper ventilation so that the indoor unit temperature does not exceed 40°C when windless.
 - Keep the heater clean, and take appropriate measures so that the indoor unit does not suck in the dust particles that accumulate on the heater.
 - Use the optional heater cable (PAC-YU25HT) to perform an interlocked operation with indoor units.
 - Do not build a heater inside the indoor unit.

Recommended circuit

Wiring diagram

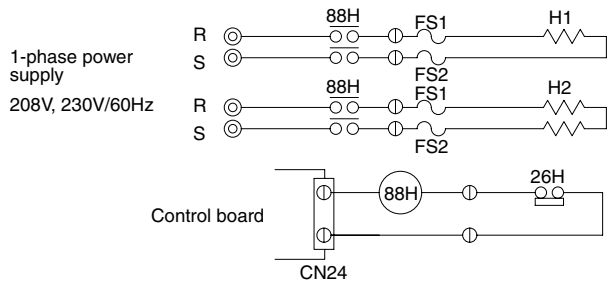

- FS1, 2 ----- Thermal fuse
- H1, H2 ----- Heater
- 26H ----- Overheat protection thermostat
- 88H ----- Electromagnetic contactor

2. Precautions for devices that use R410A refrigerant

⚠ Caution:

- **Do not use the existing refrigerant piping.**
 - The old refrigerant and refrigerator oil in the existing piping contains a large amount of chlorine which may cause the refrigerator oil of the new unit to deteriorate.
 - **Use refrigerant piping made of C1220 (Cu-DHP) phosphorus deoxidized copper as specified in the *JIS H3300 “Copper and copper alloy seamless pipes and tubes”. In addition, be sure that the inner and outer surfaces of the pipes are clean and free of hazardous sulphur, oxides, dust/dirt, shaving particles, oils, moisture, or any other contaminant.**
 - Contaminants on the inside of the refrigerant piping may cause the refrigerant residual oil to deteriorate.
- *JIS: Japanese Industrial Standard
- **Store the piping to be used during installation indoors and keep both ends of the piping sealed until just before brazing. (Store elbows and other joints in a plastic bag.)**
 - If dust, dirt, or water enters the refrigerant cycle, deterioration of the oil and compressor trouble may result.
 - **Use ester oil, ether oil or alkylbenzene (small amount) as the refrigerator oil to coat flares and flange connections.**
 - The refrigerator oil will degrade if it is mixed with a large amount of mineral oil.
 - **Use liquid refrigerant to fill the system.**
 - If gas refrigerant is used to seal the system, the composition of the refrigerant in the cylinder will change and performance may drop.
 - **Do not use a refrigerant other than R410A.**
 - If another refrigerant (R22, etc.) is used, the chlorine in the refrigerant may cause the refrigerator oil to deteriorate.
 - **Use a vacuum pump with a reverse flow check valve.**
 - The vacuum pump oil may flow back into the refrigerant cycle and cause the refrigerator oil to deteriorate.
 - **Do not use the following tools that are used with conventional refrigerants. (Gauge manifold, charge hose, gas leak detector, reverse flow check valve, refrigerant charge base, vacuum gauge, refrigerant recovery equipment)**
 - If the conventional refrigerant and refrigerator oil are mixed in the R410A, the refrigerant may deteriorate.
 - If water is mixed in the R410A, the refrigerator oil may deteriorate.
 - Since R410A does not contain any chlorine, gas leak detectors for conventional refrigerants will not react to it.
 - **Do not use a charging cylinder.**
 - Using a charging cylinder may cause the refrigerant to deteriorate.
 - **Be especially careful when managing the tools.**
 - If dust, dirt, or water gets in the refrigerant cycle, the refrigerant may deteriorate.

Series PVFY Vertical Concealed Indoor Unit



Indoor unit

Models	Cooling capacity/Heating capacity	
	kW	Btu / h
PVFY-P12E00A	3.5 / 4.0	12,000 / 13,500
PVFY-P18E00A	5.3 / 5.9	18,000 / 20,000
PVFY-P24E00A	7.0 / 7.9	24,000 / 27,000
PVFY-P30E00A	8.8 / 10.0	30,000 / 34,000
PVFY-P36E00A	10.6 / 11.7	36,000 / 40,000
PVFY-P48E00A	14.1 / 15.8	48,000 / 54,000
PVFY-P54E00A	15.8 / 17.6	54,000 / 60,000

● Indoor (Main) Unit

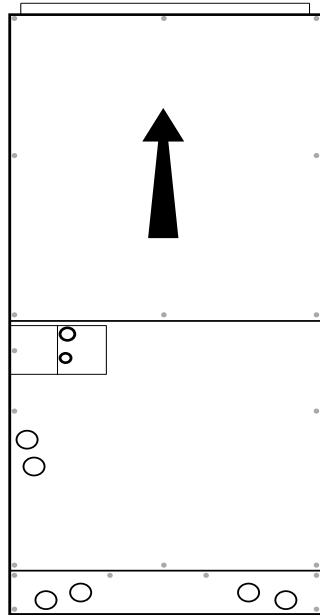

Vertical

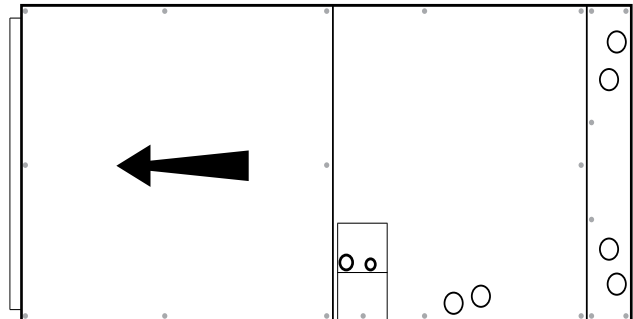

Horizontal Left

● Remote controller

[PAR-21MAA]

- Once the controls are set, the same operation mode can be repeated by simply pressing the ON/OFF button.

● Operation buttons

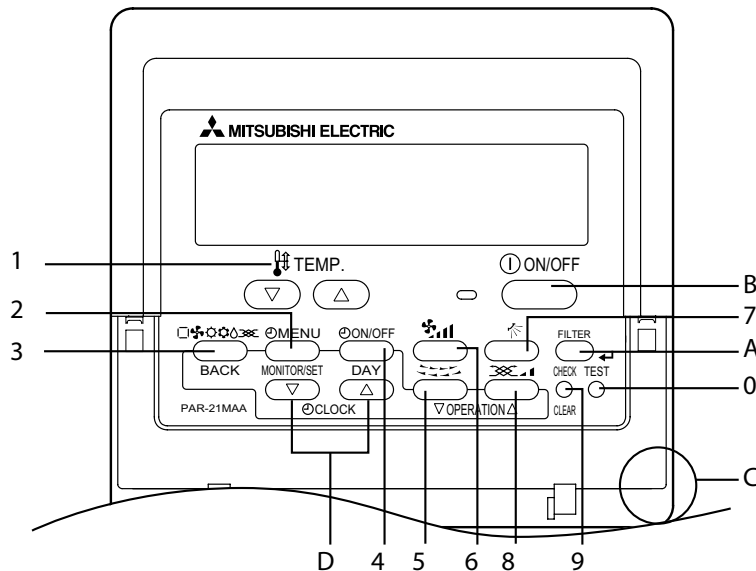

- | | | |
|----------------------------|----------------------------|---|
| 1 [Set Temperature] Button | 5 [Louver] Button | 0 [Test run] Button |
| 2 [Timer Menu] Button | [Operation] Button | A [Filter] Button |
| [Monitor/Set] Button | 6 [Fan Speed] Button | [←] Button |
| 3 [Mode] Button | 7 [Airflow Up/Down] Button | B [ON/OFF] Button |
| [Return] Button | 8 [Ventilation] Button | C Position of built-in room temperature |
| 4 [Timer On/Off] Button | [Operation] Button | D [Set Time] Button |
| [Set Day] Button | 9 [Check/Clear] Button | |

- Never expose the remote controller to direct sunlight. Doing so can result in the erroneous measurement of room temperature.
- Never place any obstacle around the lower right-hand section of the remote controller. Doing so can result in the erroneous measurement of room temperature.

[Display]

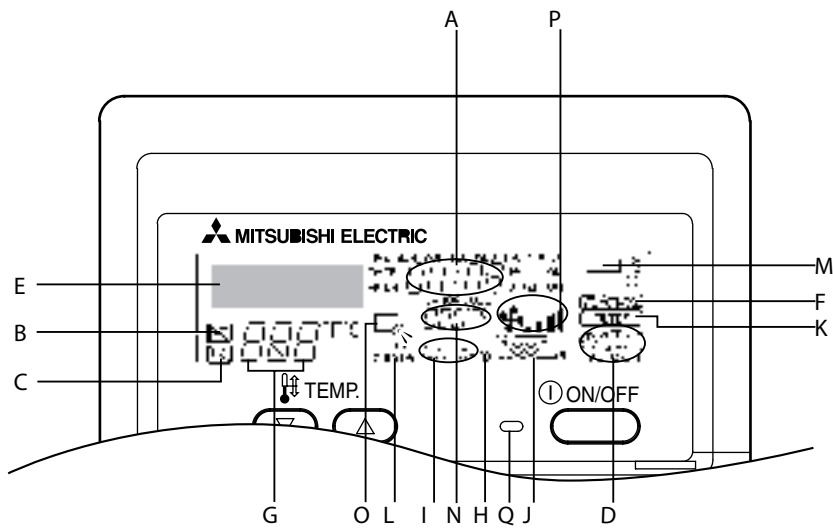

- A Current time/Timer
- B Centralized control
- C Timer OFF
- D Timer indicator
- E Operation mode: COOL, DRY, AUTO, FAN, HEAT
- F "Locked" indicator
- G Set temperature
- H Power ON
- I Louver
- J Ventilation
- K Filter sign
- L Set effective for 1 hr.
- M Sensor position
- N Room temperature
- O Airflow
- P Fan speed

3

SPECIFICATIONS

3-1. PVFY-P-E00A Specifications

PVFY Specifications										
Model Name		PVFY-P12E00A	PVFY-P18E00A	PVFY-P24E00A	PVFY-P30E00A	PVFY-P36E00A	PVFY-P48E00A	PVFY-P54E00A		
Power Source		208/230V, 1-phase, 60Hz								
Cooling Capacity		Btu/h *1	12,000	18,000	24,000	30,000	36,000	48,000	54,000	
Heating Capacity		Btu/h *1	13,500	20,000	27,000	34,000	40,000	54,000	60,000	
Power Consumption	Cooling	kW	0.171 / 0.171	0.280 / 0.280	0.258 / 0.258	0.379 / 0.379	0.324 / 0.324	0.362 / 0.362	0.410 / 0.410	
	Heating	kW	0.171 / 0.171	0.280 / 0.280	0.258 / 0.258	0.379 / 0.379	0.324 / 0.324	0.362 / 0.362	0.410 / 0.410	
Current	Cooling	A	0.69 / 0.61	1.48 / 1.31	1.48 / 1.31	2.38 / 2.11	1.93 / 1.71	2.27 / 2.01	2.83 / 2.51	
	Heating	A	0.69 / 0.61	1.48 / 1.31	1.48 / 1.31	2.38 / 2.11	1.93 / 1.71	2.27 / 2.01	2.83 / 2.51	
MCA (208 / 230V)			0.86 / 0.76	1.85 / 1.64	1.85 / 1.64	2.97 / 2.64	2.41 / 2.14	2.84 / 2.51	3.53 / 3.14	
MOCP		A	15							
Dimensions	Height	Inches	42-3/4			48		58-3/4		
	Width	Inches	17-3/4			21		24-1/2		
	Depth	Inches	21					21-3/4		
Net Weight	Unit	Pounds	88	98	108	115	120	160	168	
Heat Exchanger		Cross Fin (Aluminum Plate Fin and Copper Tube)								
Fan	Type x Qty.		Forward Curved Blower x 1							
	Airflow Rate *2	0.30 ESP	243-320-376	385-481-531	483-636-705	637-800-886	784-954-1,057	982-1,268-1,405	1,114-1,426-1,576	
		0.50 ESP	202-249-346	402-485-520	560-632-713	725-815-873	880-991-1,033	1,162-1,303-1,438	1,360-1,497-1,570	
	External Static Pressure	In. WG	0.30 / 0.50 (Selectable)							
Motor Type		High-efficiency DC								
Air Filter		Filter and Rack -field supplied								
Refrigerant Pipe Dimensions	Low Pressure (Brazed)	Inches	1/2			5/8				
	High Pressure (Brazed)	Inches	1/4			3/8				
Drain Pipe Dimension	Primary	Inches	3/4 FPT							
	Secondary		3/4 FPT							

Note: *1 Cooling/Heating capacity indicates the maximum value at operation under the following conditions:

Cooling: Indoor: 80°F (27°C) DB/67°F (19°C) WB; Outdoor: 95°F (35°C) DB

Heating: Indoor: 70°F (21°C) DB; Outdoor: 47°F (8°C) DB/43°F (6°C) WB

*2 Airflow rate / sound pressure levels are at (Low-Mid-High)

3-2. Electrical Parts Specifications

Model Parts name	Symbol	PV FY- P12E00A	PV FY- P18E00A	PV FY- P24E00A	PV FY- P30E00A	PV FY- P36E00A	PV FY- P48E00A	PV FY- P54E00A
Transformer	T1	(Primary) 240V 60Hz (Secondary) (23.5V 0.9A)						
Transformer	T2	(Primary) 208/230V 60Hz (Secondary) (27V)						
Room temperature thermistor	TH21	Resistance 0°C[32°F]/15k,10°C[50°F]/9.6k,20°C[68°F]/6.3k,25°C[77°F]/5.4k,30°C[86°F]/4.3k,40°C[104°F]/3.0k						
Liquid pipe thermistor	TH22	Resistance 0°C[32°F]/15k,10°C[50°F]/9.6k,20°C[68°F]/6.3k,25°C[77°F]/5.4k,30°C[86°F]/4.3k,40°C[104°F]/3.0k						
Gas pipe thermistor	TH23	Resistance 0°C[32°F]/15k,10°C[50°F]/9.6k,20°C[68°F]/6.3k,25°C[77°F]/5.4k,30°C[86°F]/4.3k,40°C[104°F]/3.0k						
Fuse (Indoor controller board)	FUSE	250V 6.3A						
Fan motor (with Inner-thermostat)	MF1	4-pole, 1/3 hp	4-pole, 1/3 hp	4-pole, 1/3 hp	4-pole, 1/3 hp	4-pole, 1/2 hp	4-pole, 3/4 hp	4-pole, 3/4 hp
Linear expansion valve	LEV	DC12V Stepping motor drive port dimension 3.2 (0~2000pulse) EDM-402MD			DC12V Stepping motor drive port dimension			
					5.2 (0~2000pulse) EDM-804MD			6.4 (0~2000 pulse) EDM-A0Y
Power supply terminal bed	TB2	(L1,L2,G) 330V 30A						
Transmission terminal bed	TB5 TB15	(1,2),(M1,M2,S) 330V 30A						

4

OUTLINES AND DIMENSIONS

PV FY-P12-18-24E00A

Model	(1) Gas Pipe <Braze>	(2) Liquid Pipe <Braze>	(3) Drain Conn.
PV FY-P12E00A	1/2	1/4	3/4 FPT
PV FY-P18E00A	1/2	1/4	
PV FY-P24E00A	5/8	3/8	

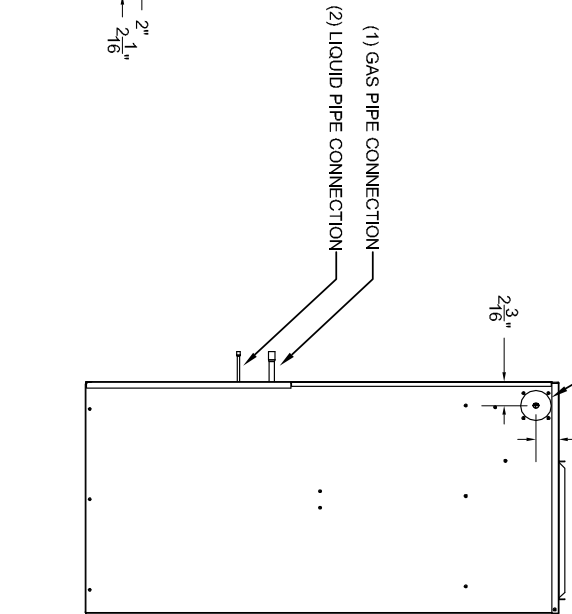
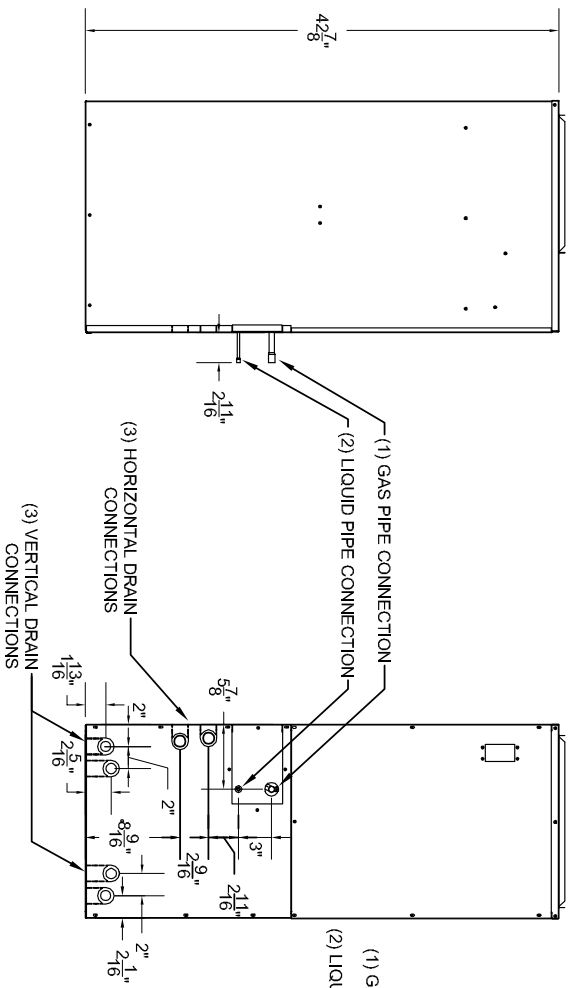
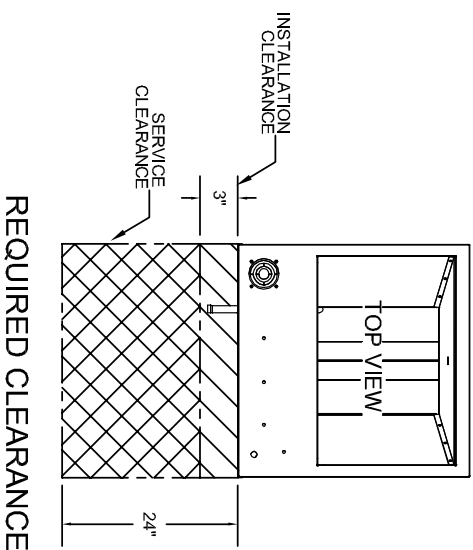
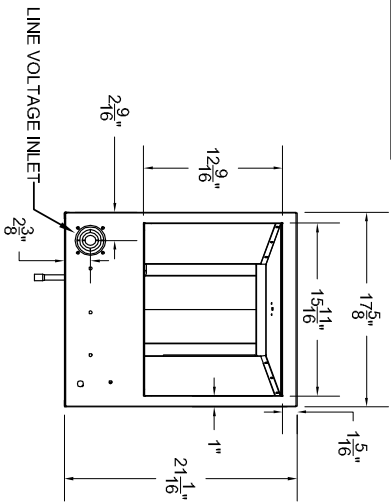

LEFT VIEW

FRONT VIEW

RIGHT VIEW

TOP VIEW

REQUIRED CLEARANCE

PV FY-P30-36E00A

Model	(1) Gas Pipe <Braze>	(2) Liquid Pipe <Braze>	(3) Drain Conn.
PV FY-P30E00A	5/8	3/8	
PV FY-P36E00A	5/8	3/8	3/4 FPT

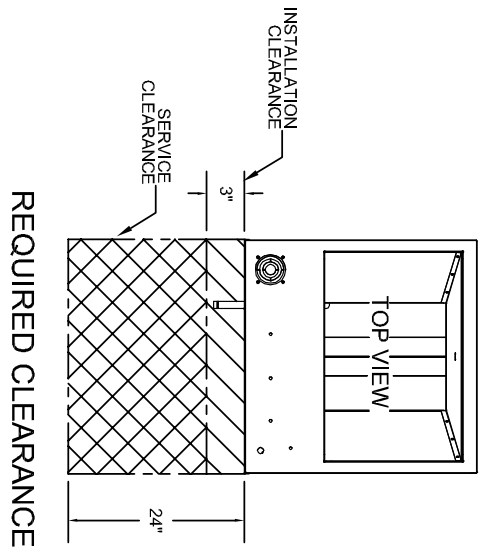
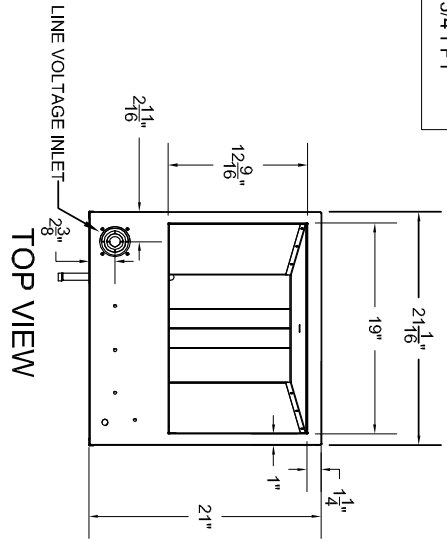
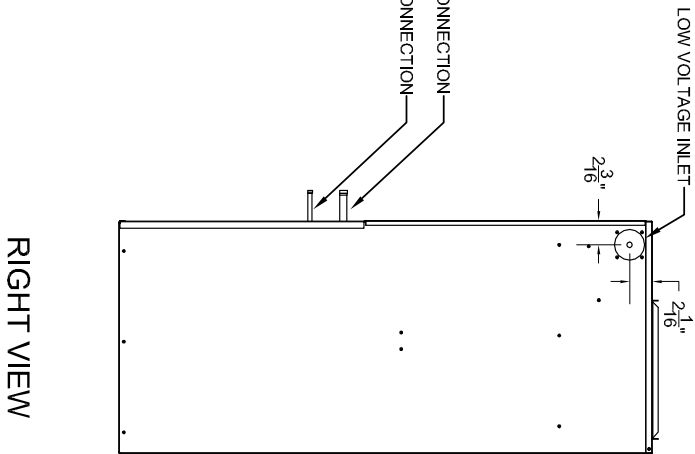
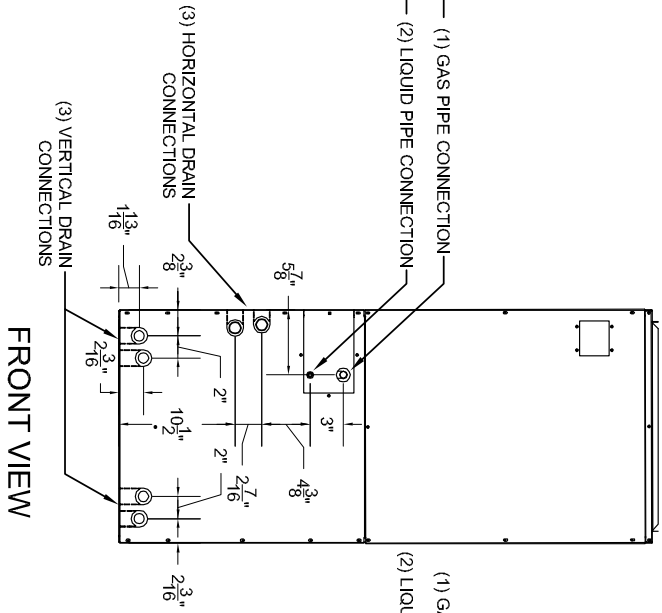
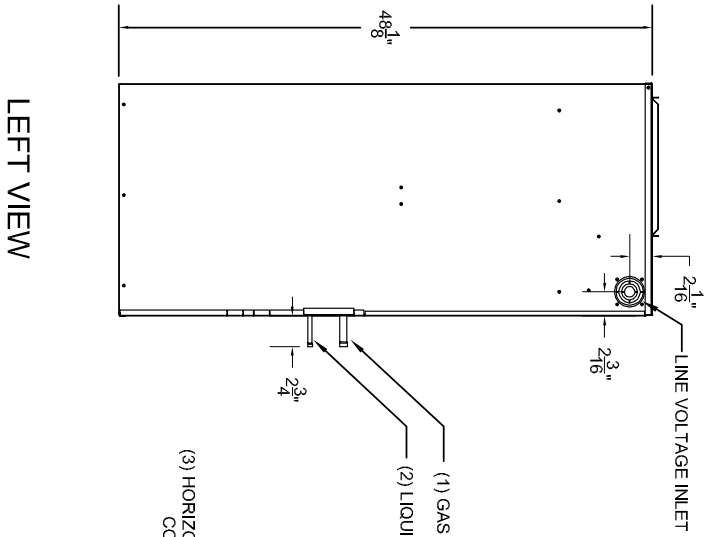

PV FY-P48-54E00A

Model	(1) Gas Pipe <Braze>	(2) Liquid Pipe <Braze>	(3) Drain Conn.
PV FY-P48E00A	5/8	3/8	
PV FY-P54E00A	5/8	3/8	3/4 FPT

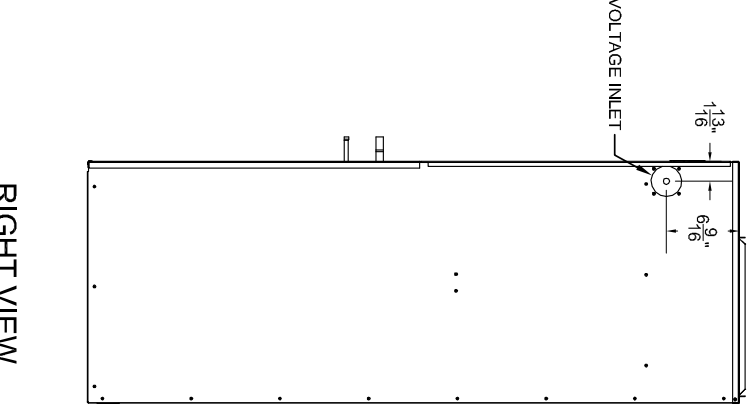
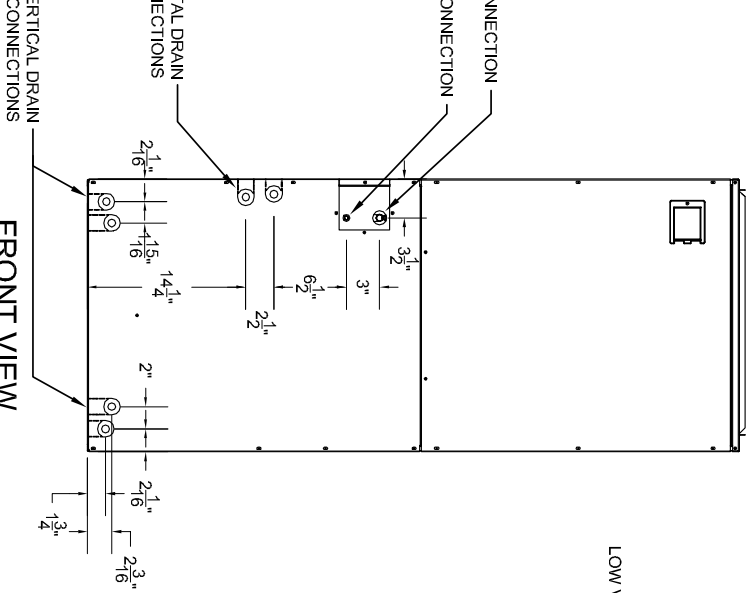
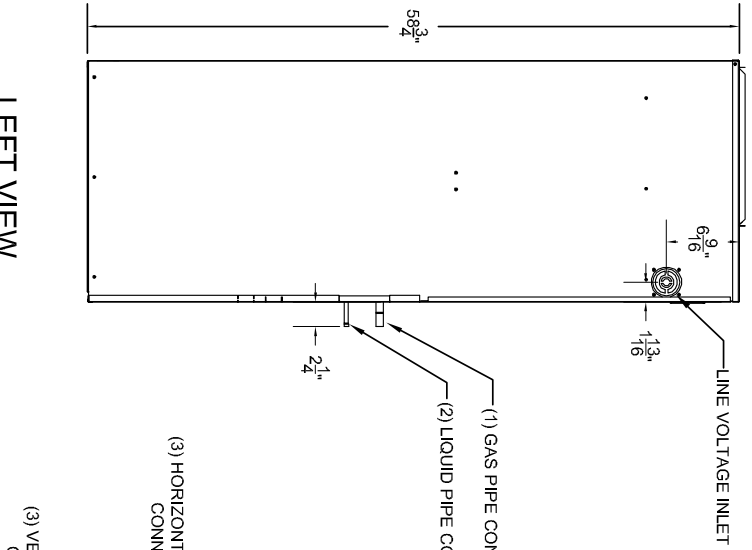
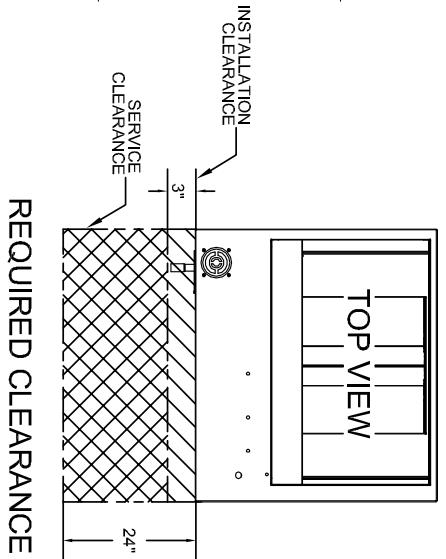
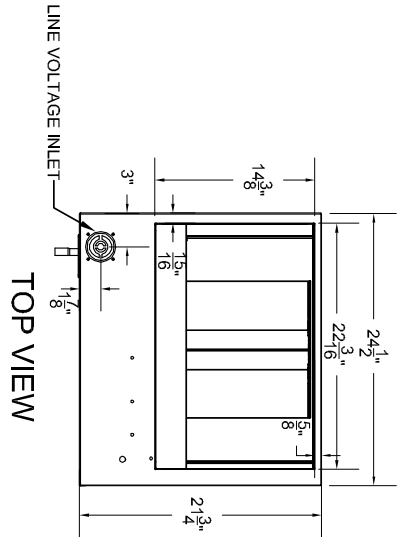

PV FY-P12,18, P24, P30, P36, P48, P54E00A

INSIDE SECTION OF CONTROL BOX

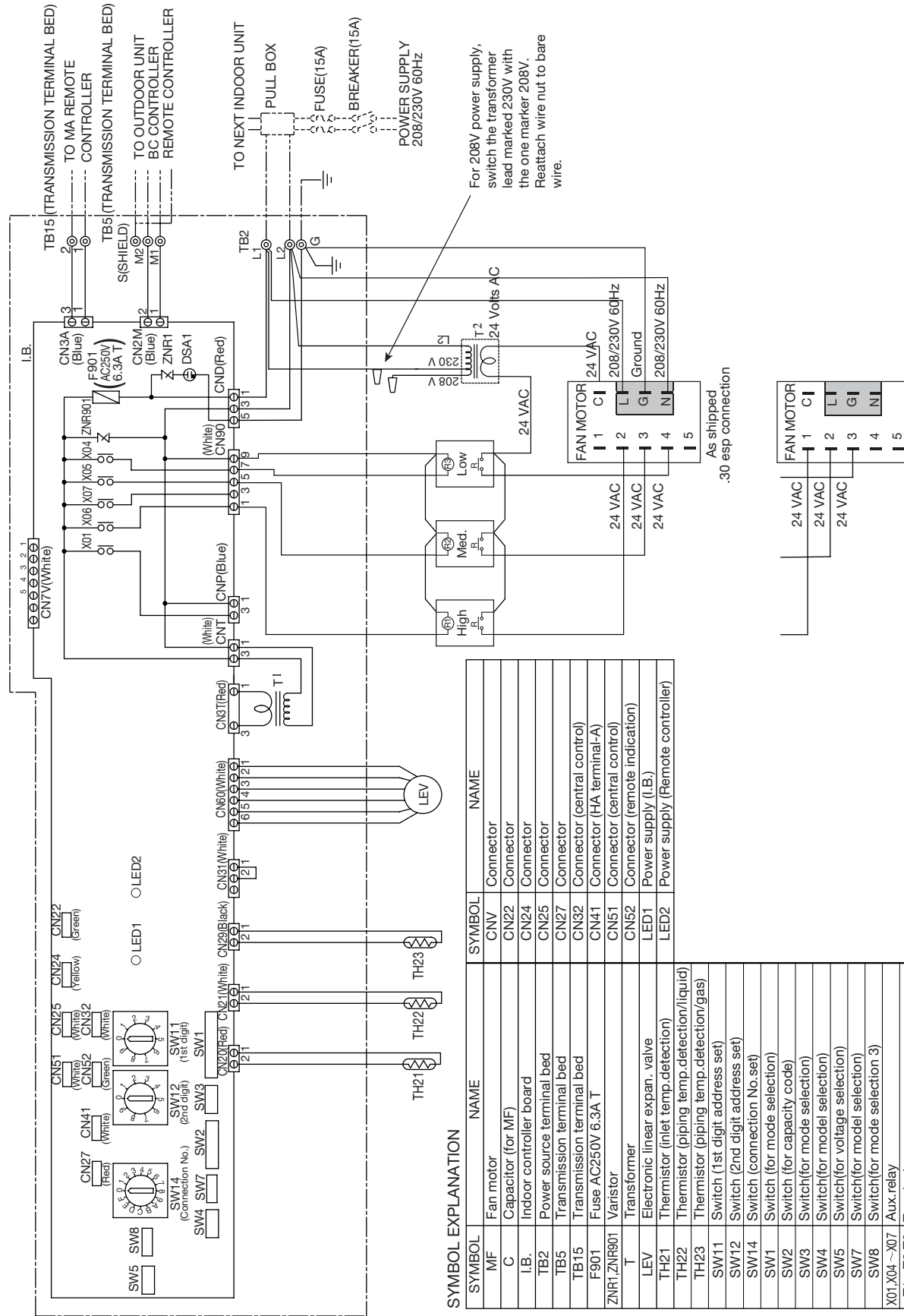

SYMBOL EXPLANATION

SYMBOL	NAME	SYMBOL	NAME
MF	Fan motor	CNV	Connector
C	Capacitor (for MF)	CN22	Connector
I.B.	Indoor controller board	CN24	Connector
TB2	Power source terminal bed	CN25	Connector
TB5	Transmission terminal bed	CN27	Connector
TB15	Transmission terminal bed	CN32	Connector (central control)
F901	Fuse AC250V 6.3A T	CN41	Connector (HA terminal-A)
ZNR1,ZNR001	Varistor	CN51	Connector (central control)
T	Transformer	CN52	Connector (remote indication)
LEV	Electronic linear expan. valve	LED1	Power supply (I.B.)
TH21	Thermistor (inlet temp.detection)	LED2	Power supply (Remote controller)
TH22	Thermistor (piping temp.detection/liquid)		
TH23	Thermistor (piping temp.detection/gas)		
SW11	Switch (1st digit address set)		
SW12	Switch (2nd digit address set)		
SW14	Switch (connection No.set)		
SW1	Switch (for mode selection)		
SW2	Switch (for capacity code)		
SW3	Switch(for mode selection)		
SW4	Switch(for model selection)		
SW5	Switch(for voltage selection)		
SW7	Switch(for model selection)		
X01,X04-X07	Aux.relay		
<T1>,T2,T3	Terminal		

For 208V power supply, switch the transformer lead marked 230V with the one marked 208V. Reattach wire nut to bare wire.

For 208V power supply, switch the transformer lead marked 230V with the one marked 208V. Reattach wire nut to bare wire.

As shipped .30 esp connection

For field selected .50 esp, change low voltage connections as shown

6

REFRIGERANT SYSTEM DIAGRAM

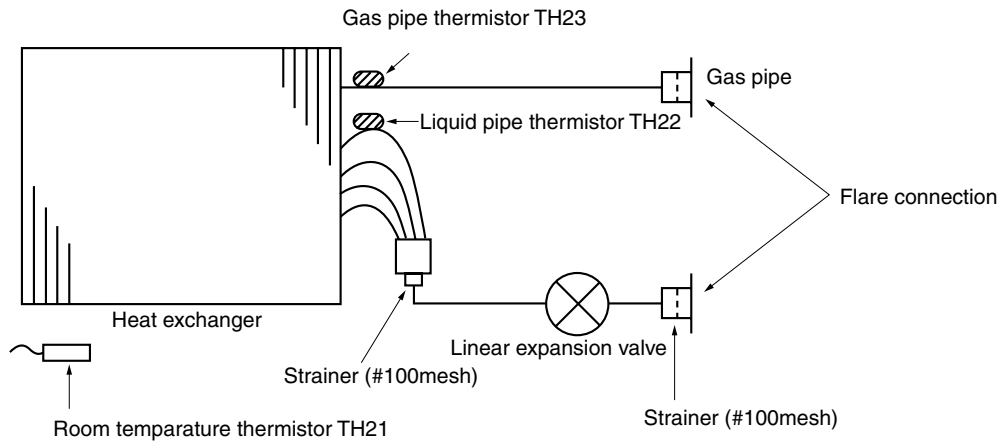

mm <in.>

Item	Capacity	PVFY-P12,18E00A
Gas pipe	R410A	∅ 12.7 (1/2)
Liquid pipe	R410A	∅ 6.35 (1/4)

mm <in.>

Item	Capacity	PVFY-P24, 30, 36, 45, 54E00A
Gas pipe	R410A	∅ 15.88 (5/8)
Liquid pipe	R410A	∅ 9.52 (3/8)

Electrical Component Location

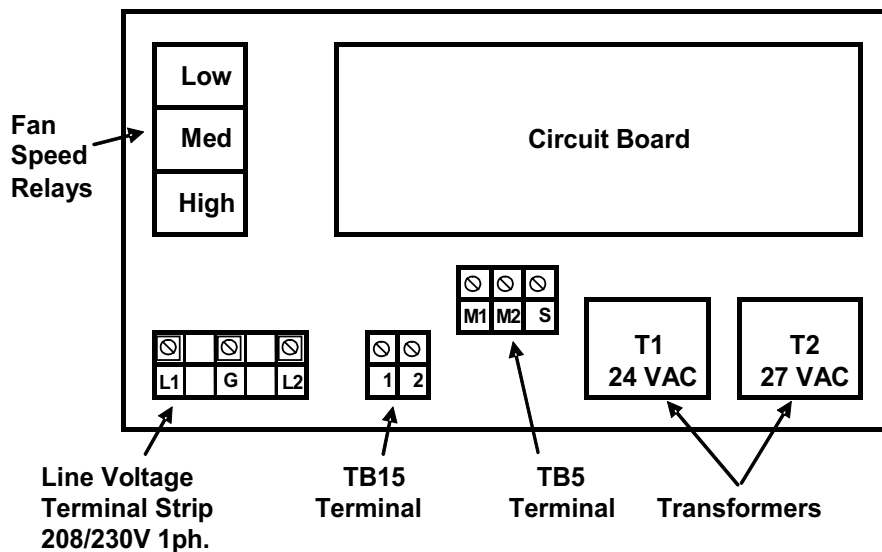

7-1. How to check the parts

Parts name	Check points				
Room temperature thermistor (TH21) Liquid pipe thermistor (TH22) Gas pipe thermistor (TH23)	Disconnect the connector, then measure the resistance using a tester. (Surrounding temperature 10°C~30°C[50°F~86°F])				
	<table border="1"> <thead> <tr> <th>Normal</th> <th>Abnormal</th> </tr> </thead> <tbody> <tr> <td>4.3k ~9.6k</td> <td>Open or short</td> </tr> </tbody> </table> <p>(Refer to the thermistor)</p>	Normal	Abnormal	4.3k ~9.6k	Open or short
Normal	Abnormal				
4.3k ~9.6k	Open or short				

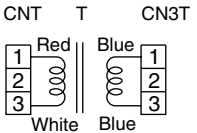
Parts name	Check points								
Transformer 24V	Disconnect the connector and measure the resistance using a tester.								
	<table border="1"> <thead> <tr> <th></th> <th>Normal</th> <th>Abnormal</th> </tr> </thead> <tbody> <tr> <td>CNT(1)-(3)</td> <td>App.45</td> <td rowspan="2">Open or short</td> </tr> <tr> <td>CN3T(1)-(3)</td> <td>App.1</td> </tr> </tbody> </table>		Normal	Abnormal	CNT(1)-(3)	App.45	Open or short	CN3T(1)-(3)	App.1
	Normal	Abnormal							
CNT(1)-(3)	App.45	Open or short							
CN3T(1)-(3)	App.1								

Transformer 27VAC

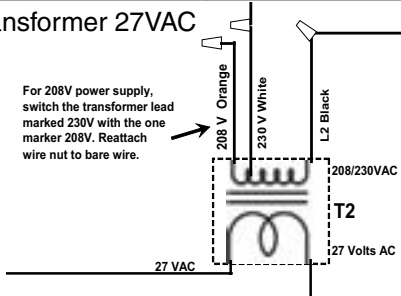

Make sure the proper transformer lead is connected for the proper supply voltage. See diagram at left.

Measure the supply voltage to the transformer. The supply voltage should be between 187 and 229 volts if the transformer is connected to a 208 volt power supply. The reading should be between 207 and 253 volts if connected to a 230 volt power supply.

With the proper supply voltage, the transformer output voltage should be approximately 27 volts. If no voltage is measured, replace the transformer.

Fan Relays

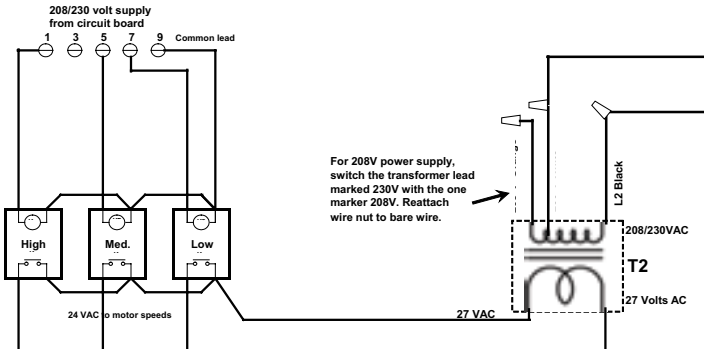

There are 3 fan relays. One relay for each high, medium and low speed operation. The fan relays have a 208/240 V AC coil that is energized by the circuit board. The relay switches a 24 V AC circuit, which provides the speed signal for the motor. The relay energized will be determined by which speed is selected at the controller.

To check operation:
Make sure power to the system is on and the unit is not in standby mode.

1. Select high, medium or low speed at the controller.
2. At the corresponding relay based on the speed selected, check the voltage across the relay coil which is supplied from the circuit board.
3. If 208/230 V is measured, go on to step 4. If no voltage is measured, replace the circuit board.
4. If there is voltage present, the relay contact should be closed.
5. To check the contact. Turn power off. Remove the 24 V wires from relay contact.
6. Reapply voltage and select the fan speed. Check the continuity across the contact. If there is no continuity across the contact, replace the relay. If there is continuity across the contact, the relay is OK. Refer to the motor troubleshooting section.

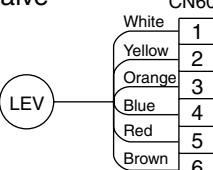
Parts name	Check points														
Linear expansion valve	Disconnect the connector then measure the resistance valve using a tester. Refer to the next page for a detail.														
	<table border="1"> <thead> <tr> <th colspan="4">Normal</th> <th>Abnormal</th> </tr> </thead> <tbody> <tr> <td>(1)-(5) White-Red</td> <td>(2)-(6) Yellow-Brown</td> <td>(3)-(5) Orange-Red</td> <td>(4)-(6) Blue-Brown</td> <td rowspan="2">Open or short</td> </tr> <tr> <td colspan="2">150</td> <td colspan="2">10%</td> </tr> </tbody> </table>	Normal				Abnormal	(1)-(5) White-Red	(2)-(6) Yellow-Brown	(3)-(5) Orange-Red	(4)-(6) Blue-Brown	Open or short	150		10%	
Normal				Abnormal											
(1)-(5) White-Red	(2)-(6) Yellow-Brown	(3)-(5) Orange-Red	(4)-(6) Blue-Brown	Open or short											
150		10%													

<Thermistor Characteristic graph>

Thermistor for lower temperature

Room temperature thermistor(TH21)
Liquid pipe thermistor(TH22)
Gas pipe temperature thermistor(TH23)

Thermistor R₀=15k 3%
Fixed number of B=3480k 2%

$$R_t = 15 \exp \left\{ 3480 \left(\frac{1}{273+t} - \frac{1}{273} \right) \right\}$$

0°C	32°F	15k
10°C	50°F	9.6k
20°C	68°F	6.3k
25°C	77°F	5.2k
30°C	86°F	4.3k
40°C	104°F	3.0k

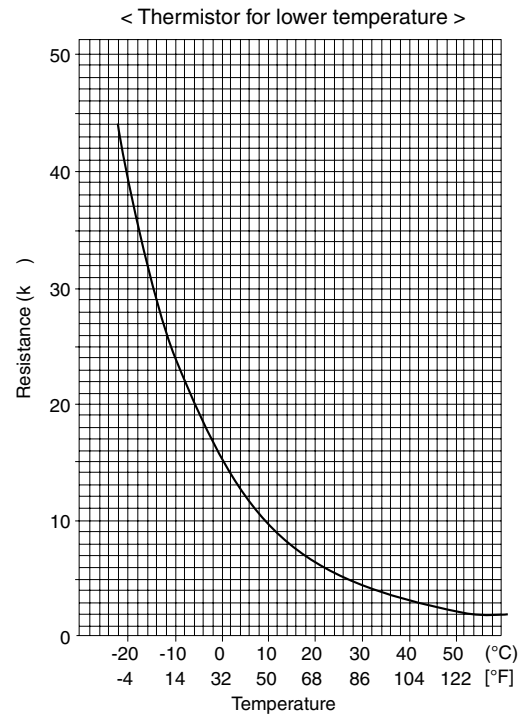

Linear expansion valve

① Operation summary of the linear expansion valve.

- Linear expansion valve open/close through stepping motor after receiving the pulse signal from the indoor controller board.
- Valve position can be changed in proportion to the number of pulse signal.

<Connection between the indoor controller board and the linear expansion valve>

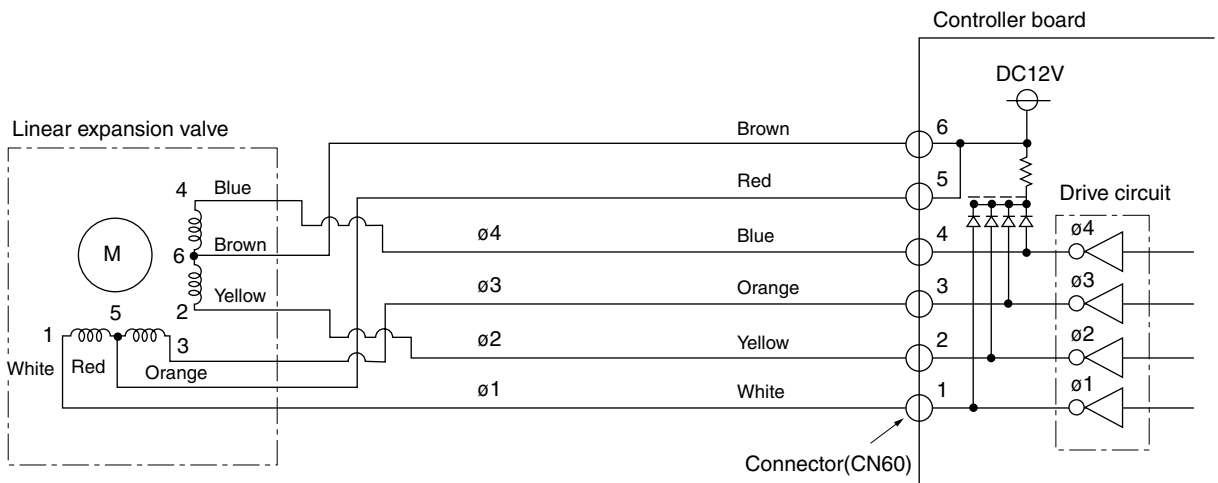

<Output pulse signal and the valve operation>

Output (Phase)	Output			
	1	2	3	4
∅1	ON	OFF	OFF	ON
∅2	ON	ON	OFF	OFF
∅3	OFF	ON	ON	OFF
∅4	OFF	OFF	ON	ON

Closing a valve : 1 → 2 → 3 → 4 → 1
 Opening a valve : 4 → 3 → 2 → 1 → 4

The output pulse shifts in above order.

- * 1. When linear expansion valve operation stops, all output phase become OFF.
- 2. At phase interruption or when phase does not shift in order, motor does not rotate smoothly and motor will locks and vibrates.

② Linear expansion valve operation

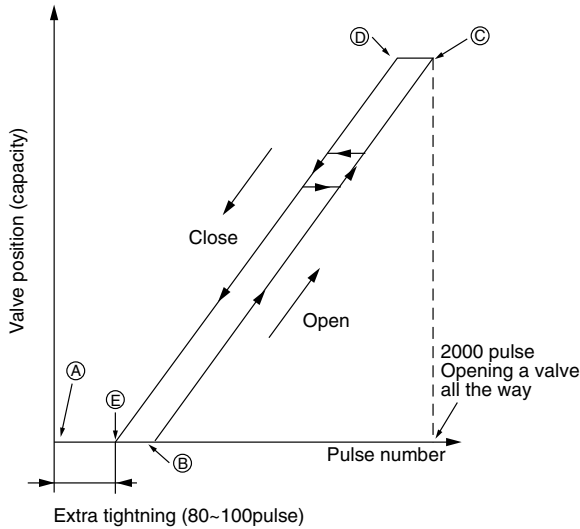

- * When the switch is turned on, 2200 pulse closing valve signal will be send till it goes to A point in order to define the valve position.

When the valve move smoothly, there is no noise or vibration occurring from the linear expansion valve : however, when the pulse number moves from E to A or when the valve is locked, more noise can be heard than normal situation.

- * Noise can be detected by placing the ear against the screw driver handle while putting the screw driver to the linear expansion valve.

③ Trouble shooting

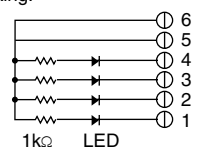
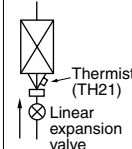
Symptom	Check points	Countermeasures
Operation circuit failure of the micro processor.	Disconnect the connector on the controller board, then connect LED for checking.  Pulse signal will be sent out for 10 seconds as soon as the main switch is turn on. If there is LED with lights on or lights off, it means the operation circuit is abnormal.	Exchange the indoor controller board at drive circuit failure.
Linear expansion valve mechanism is locked.	Motor will idle and make ticking noise when motor is operated while the linear expansion valve is locked. This ticking sound is the sign of the abnormality.	Exchange the linear expansion vale.
Short or breakage of the motor coil of the linear expansion valve.	Measure the resistance between the each coil (red-white, red-orange, brown-yellow, brown-blue) using a tester. It is normal if the resistance is in the range of $150\Omega \pm 10\%$.	Exchange the linear expansion valve.
Valve doesn't close completely (thermistor leaking).	To check the linear expansion valve, operate the indoor unit in fan mode and at the same time operate other indoor units in cooling mode, then check the pipe temperature <liquid pipe temperature> of the indoor unit by the outdoor multi controller board operation monitor. During fan operation, linear expansion valve is closed completely and if there are some leaking, detecting temperature of the thermistor will go lower. If the detected temperature is much lower than the temperature indicated in the remote controller, it means the valve is not closed all the way. It is not necessary to exchange the linear expansion valve, if the leakage is small and not making any trouble. 	If large amount of refrigeration is leaked, exchange the linear expansion valve.
Wrong connection of the connector or contact failure.	Check the color of lead wire and missing terminal of the connector.	Disconnect the connector at the controller board, then check the continuity.

7-2. Fan Motor Troubleshooting

All Models

If the motor rocks back and forth on start up, this is normal—do not replace the motor. The motor may surge if operating outside the design static pressure range. Verify that the system design static matches the selected motor static pressure settings.

The system is noisy and does not change speeds based on commands from the remote controller or the indoor unit is going into freeze protection cycle.

Check to make sure the airflow settings are correct for the installation per the indoor unit specifications. First remove the system filter and check that all dampers and diffusers are open. If after removing the filter this corrects the problem, change or clean the filter. Also, check the indoor unit heat exchanger and clean as necessary.

If none of this corrects the problem, check the static pressure of the system. The static pressure should fall within the guidelines given on the airflow charts. If it's outside the parameters given on these charts, correct the airflow problem. Make sure the static pressure setting on the motor matches the system requirements.

If the above checks do not solve the problem, check that the supply voltage applied to the motor is correct. Measure voltage at the (L), (G), (N) connector shown on the diagram below. The motor supply voltage should be + or -10% of the nominal 208/230VAC rating. If the supply voltage is not within this range, correct this before any further troubleshooting.

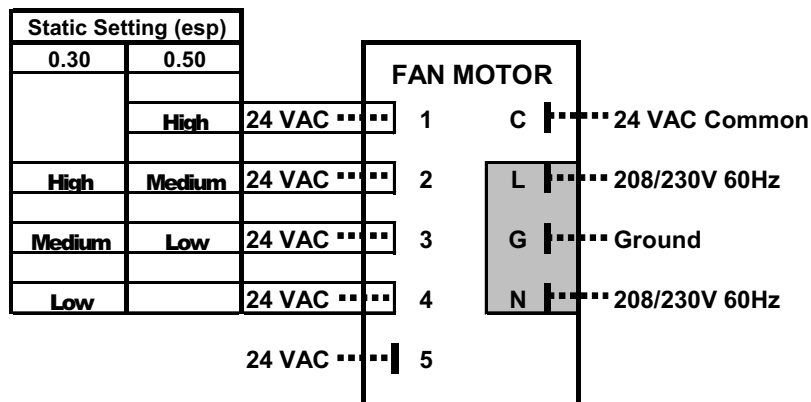

The motor does not run.





























Check for the proper line voltage power supply and ground at the (L), (G), and (N) connections. Correct any voltage issues before proceeding to the next step.

Speed selections on the blower motor are done by 24 volt supply to the motor terminals. The low voltage connections are programmed for the operating characteristics as shown in the chart above.

Turn the indoor unit on and set to any mode that will normally run the fan. (Heat, Cool or Fan) If there is no 24 volt power supply between terminals 2, 3, or 4 and C common, check the wire(s) from the relays located in the control box.





If the line voltage supply is within range and 24 volts is supplied to any of the connector combinations shown in the chart above and the motor does not operate, replace the motor.

7-3. Dip Switch Settings

Switch	Pole	Function	Operation by switch		Remarks																						
			ON	OFF																							
SW1 Mode Selection	1	Thermistor<Intake temperature detection>position	Built-in remote controller	Indoor unit	<div style="border: 1px solid black; padding: 5px; width: fit-content;">Address board</div> <p style="text-align: center;"><At delivery></p> 																						
	2	Filter clogging detection	Provided	Not provided																							
	3	Filter life	2,500hr	100hr																							
	4	Air intake	Effective	Not effective																							
	5	Remote indication switching	Thermostat ON signal indication	Fan output indication																							
	6	Humidifier control	Always operated while the heat is ON	Operated depends on the condition																							
	7	Air flow	Low	Extra low																							
	8	Heat thermostat OFF	Setting air flow	Reset to SW1-7																							
	9	Auto reset function	Effective	Not effective																							
	10	Power ON/OFF	Effective	Not effective																							
SW2 Capacity code setting	1~6	<table border="1" style="width: 100%; text-align: center;"> <thead> <tr> <th>MODELS</th> <th>SW2</th> <th>MODELS</th> <th>SW2</th> <th>MODELS</th> <th>SW2</th> </tr> </thead> <tbody> <tr> <td>PVFY-P12E00A</td> <td>ON OFF </td> <td>PVFY-P30E00A</td> <td>ON OFF </td> <td>PVFY-P48E00A</td> <td>ON OFF </td> </tr> <tr> <td>PVFY-P18E00A</td> <td>ON OFF </td> <td>PVFY-P36E00A</td> <td>ON OFF </td> <td>PVFY-P54E00A</td> <td>ON OFF </td> </tr> <tr> <td>PVFY-P24E00A</td> <td>ON OFF </td> <td></td> <td></td> <td></td> <td></td> </tr> </tbody> </table>	MODELS	SW2	MODELS	SW2	MODELS	SW2	PVFY-P12E00A	ON OFF 	PVFY-P30E00A	ON OFF 	PVFY-P48E00A	ON OFF 	PVFY-P18E00A	ON OFF 	PVFY-P36E00A	ON OFF 	PVFY-P54E00A	ON OFF 	PVFY-P24E00A	ON OFF 					<div style="border: 1px solid black; padding: 5px; width: fit-content;">Indoor controller board</div> <p>Set while the unit is off.</p> <p style="text-align: center;"><At delivery></p> <p>Set for each capacity.</p>
		MODELS	SW2	MODELS	SW2	MODELS	SW2																				
		PVFY-P12E00A	ON OFF 	PVFY-P30E00A	ON OFF 	PVFY-P48E00A	ON OFF 																				
PVFY-P18E00A	ON OFF 	PVFY-P36E00A	ON OFF 	PVFY-P54E00A	ON OFF 																						
PVFY-P24E00A	ON OFF 																										
SW3 Function Selection	1~10	<table border="1" style="width: 100%; text-align: center;"> <thead> <tr> <th>MODELS</th> <th>SW3</th> <th>MODELS</th> <th>SW3</th> </tr> </thead> <tbody> <tr> <td>PVFY-P24, 30E00A</td> <td>ON OFF </td> <td>PVFY-P12, 18, 36, 48, 54E00A</td> <td>ON OFF </td> </tr> </tbody> </table>	MODELS	SW3	MODELS	SW3	PVFY-P24, 30E00A	ON OFF 	PVFY-P12, 18, 36, 48, 54E00A	ON OFF 	<div style="border: 1px solid black; padding: 5px; width: fit-content;">Indoor controller board</div> <p>Set while the unit is off.</p>																
		MODELS	SW3	MODELS	SW3																						
PVFY-P24, 30E00A	ON OFF 	PVFY-P12, 18, 36, 48, 54E00A	ON OFF 																								
SW4 Unit Selection	1~4	PVFY-P12~54E00A ON OFF  <p style="text-align: center;"><At delivery></p>	<div style="border: 1px solid black; padding: 5px; width: fit-content;">Indoor controller board</div> <p>Set while the unit is off.</p>																								

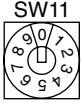
Note :The DipSW setting is effective during unit stopping (remote controller OFF) for SW1,2,3 and 4 commonly and the power source is not required to reset.



Switch	Pole	Operation by switch	Remarks
SW11 1st digit address setting SW12 2nd digit address setting Note: 1	Rotary switch	  SW12 SW11 10 1 Address setting should be done when network remote controller (PAR-F25MA) is being used.	<div style="border: 1px solid black; padding: 2px; text-align: center;">Address board</div> <p>Address can be set while the unit is stopped.</p> <p><At delivery> SW12 SW11</p>  
SW14 Connect ion No setting Note: 1	Rotary switch	 SW14 This is the switch to be used when the indoor unit is operated with R2 series outdoor unit as a set.	<div style="border: 1px solid black; padding: 2px; text-align: center;">Address board</div> <p><At delivery> SW14</p> 

Note 1: The DipSW setting is effective while the unit is not operating (remote controller OFF) for SW 11, 12, 14, and 5.

MANUFACTURED FOR:
MITSUBISHI ELECTRIC & ELECTRONICS USA, 2009