

FAN AND FUNCTIONAL PARTS

PCA-A24GA PCA-A30GA

PCA-A36GA PCA-A42GA

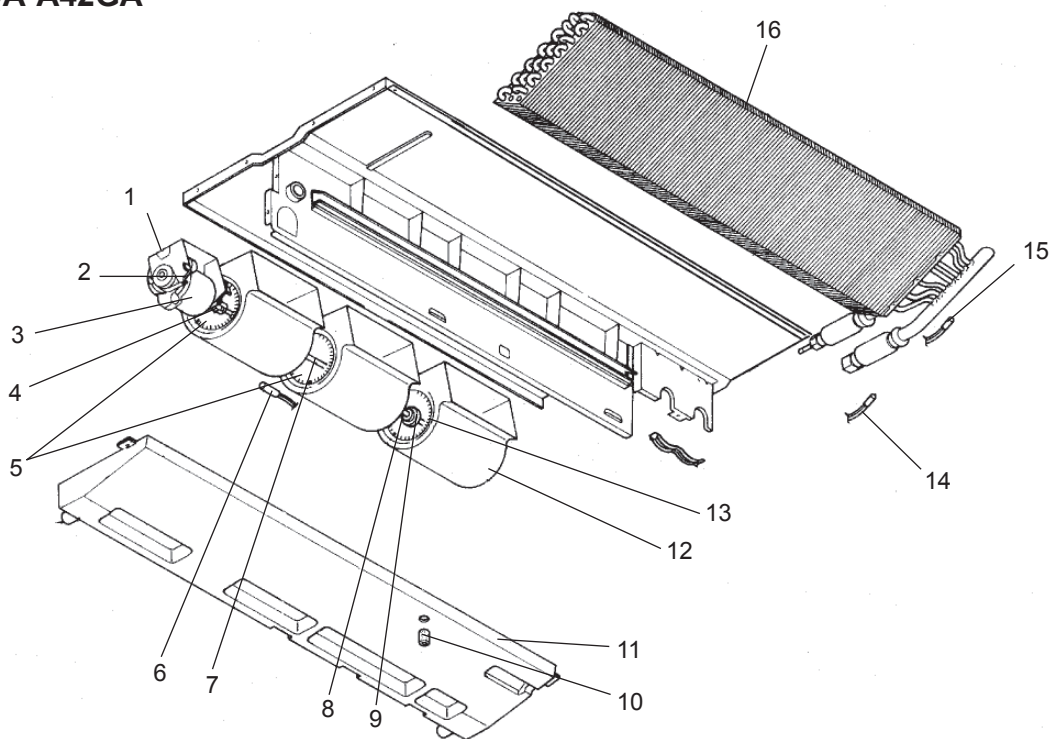

No.	Parts No.	Parts Name	Specifications	Q'ty/set		Remarks (Drawing No.)	Wiring Diagram Symbol	Recom- mended Q'ty
				PCA-A				
				24/30	36/42			
1	R01 29J 130	MOTOR LEG		1				
	R01 35J 130	MOTOR LEG			1			
2	R01 43E 126	PIECE(MOTOR)		1	1			
3	T7W 30J 762	FAN MOTOR	D09C4P70MS	1			MF	
	T7W E14 762	FAN MOTOR	D10C4P90MS		1		MF	
4	R01 700 116	SHAFT JOINT		1	1			
5	R01 E17 114	SIROCCO FAN		2				
	R01 E19 114	SIROCCO FAN			2			
6	R01 E26 202	ROOM TEMPERATURE THERMISTOR		1	1		TH1	
7	R01 29J 100	SHAFT		1	1			
8	R01 E00 103	SLEEVE BEARING		1	1			
9	R01 29J 145	BEARING SUPPORT		1				
	R01 35J 145	BEARING SUPPORT			1			
10	R01 17J 524	DRAIN PLUG		1	1			
11	T7W E20 529	DRAIN PAN ASSY		1				
	T7W E15 529	DRAIN PAN ASSY			1			
12	R01 17J 110	CASING		3				
	R01 35J 110	CASING			3			
13	R01 E15 114	SIROCCO FAN		1				
	R01 E20 114	SIROCCO FAN			1			
14	R01 E27 202	LIQUID PIPE TEMPERATURE THERMISTOR		1	1		TH2	
15	R01 17J 202	COND/EVA TEMPERATURE THERMISTOR		1	1		TH5	
16	T7W H23 480	HEAT EXCHANGER		1				
	T7W H24 480	HEAT EXCHANGER			1			

STRUCTURAL PART

PCA-A24GA
PCA-A30GA
PCA-A36GA
PCA-A42GA

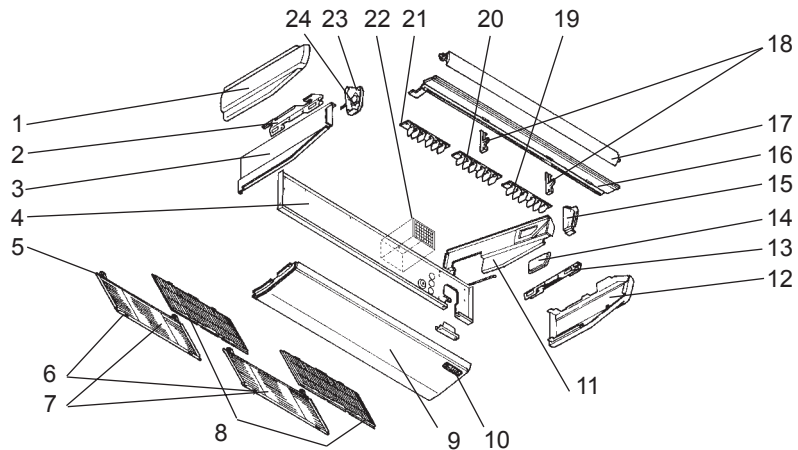

Part numbers that are circled are not shown in the figure.

No.	Parts No.	Parts Name	Specifications	Q'ty/set		Remarks (Drawing No.)	Wiring Diagram Symbol	Recom- mended Q'ty
				PCA-A				
				24/30	36/42			
1	R01 17J 662	LEFT SIDE PANEL		1				
	R01 35J 662	LEFT SIDE PANEL			1			
2	R01 17J 809	LEFT LEG		1	1			
3	T7W E01 666	S.PLATE-L		1				
	T7W E00 666	S.PLATE-L			1			
4	T7W E05 676	REAR PANEL		1				
	T7W E00 676	REAR PANEL			1			
5	R01 17J 061	GRILLE HINGE		4	4			
6	R01 17J 054	GRILLE CATCH		4	4			
7	R01 17J 691	GRILLE ASSY		2	2			
8	R01 A14 500	L.L FILTER		2	2			
9	R01 29J 669	UNDER PANEL		1	1			
10	T7W E01 070	W.BOARD CASE		1	1			
11	T7W E01 665	S.PLATE-R		1				
	T7W E00 665	S.PLATE-R			1			
12	R01 17J 661	RIGHT SIDE PANEL		1				
	R01 35J 661	RIGHT SIDE PANEL			1			
13	R01 17J 808	RIGHT LEG		1	1			
14	T7W E05 668	SERVICE PANEL		1				
	T7W E01 668	SERVICE PANEL			1			
15	R01 17J 067	RIGHT SIDE BOX		1				
	R01 35J 067	RIGHT SIDE BOX			1			
16	T7W E05 651	FRONT PANEL		1				
	T7W E00 651	FRONT PANEL			1			
17	R01 29J 002	AUTO VANE		1				
	R01 E03 002	AUTO VANE			1			
18	R01 E00 033	VANE SUPPORT		2				
	R01 E01 033	VANE SUPPORT			2			
19	R01 37J 085	G.V ASSY-6R		1	1			
20	R01 37J 087	G.V ASSY-6C		1	1			
21	R01 37J 086	G.V ASSY-6L		1	1			
22	T7W E01 501	AIR FILTER		1				
	T7W 051 501	AIR FILTER			1			
23	R01 17J 068	LEFT SIDE BOX		1				
	R01 E00 068	LEFT SIDE BOX			1			
24	R01 29J 223	VANE MOTOR		1			MV	
	R01 35J 223	VANE MOTOR			1		MV	
25	R01 17J 523	JOINT SOCKET		1	1			
26	T7W E00 072	DRAIN HOSE COVER		1	1			

ELECTRICAL PARTS

PCA-A24GA

PCA-A30GA

PCA-A36GA

PCA-A42GA

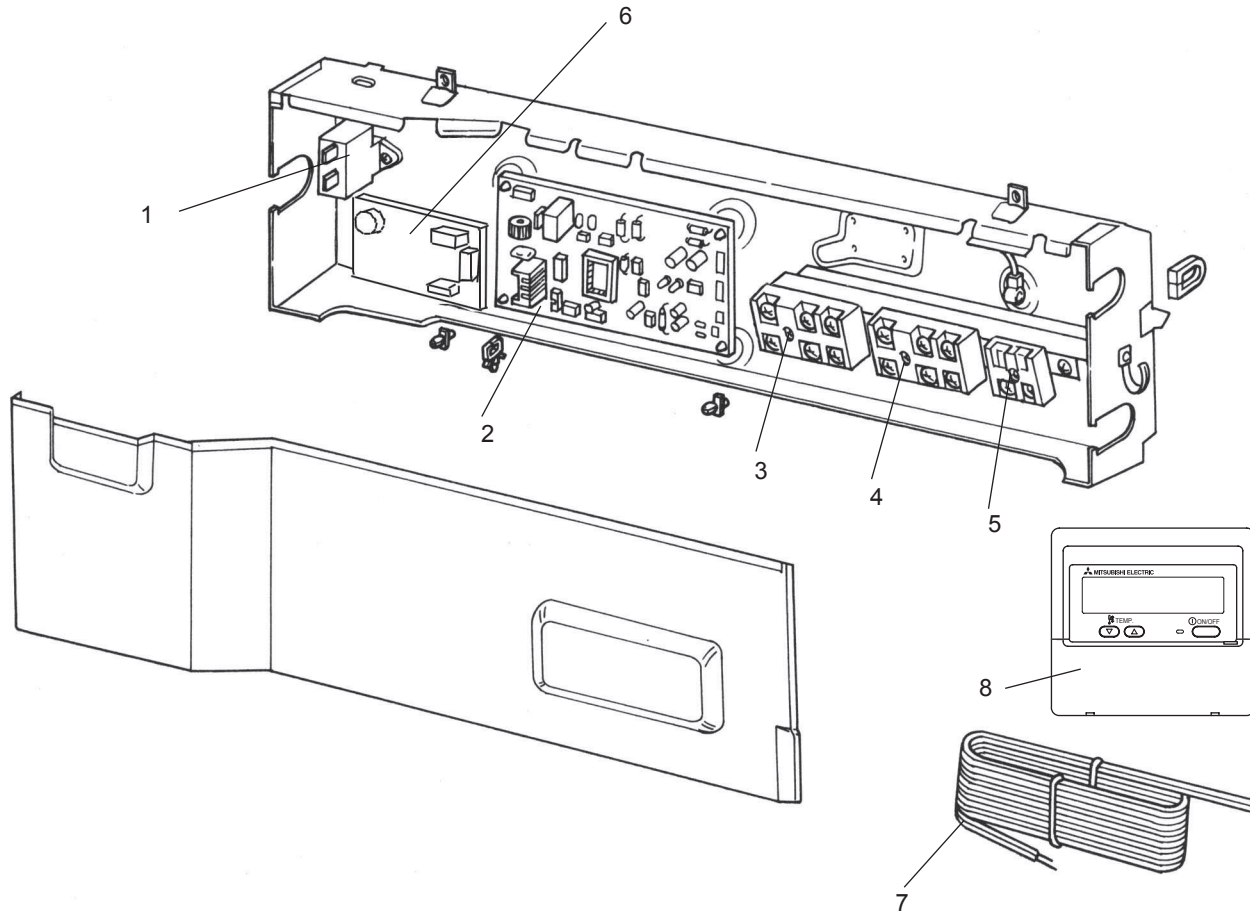

No.	Parts No.	Parts Name	Specifications	Q'ty/ set		Remarks (Drawing No.)	Wiring Diagram Symbol	Recom- mended Q'ty
				PCA-A				
				24/30	36/42			
1	T7W E18 255	CAPACITOR	4 μ F 440V	1			C	
	T7W E19 255	CAPACITOR	5 μ F 440V		1		C	
2	T7W E56 310	INDOOR CONTROLLER BOARD		1	1		I.B	
3	T7W E41 716	TERMINAL BLOCK	3P(L1,L2,GR)	1	1		TB2	
4	R01 E18 246	TERMINAL BLOCK	3P(S1,S2,S3)	1	1		TB4	
5	R01 E21 246	TERMINAL BLOCK	2P(1,2)	1	1		TB5	
6	T7W E35 313	POWER BOARD		1	1		P.B	
7	T7W A01 305	REMOTE CONTROLLER CORD		1	1			
8	T7W E14 713	REMOTE CONTROLLER	PAR-21MAA	1	1		R.B	

FAN AND FUNCTIONAL PARTS

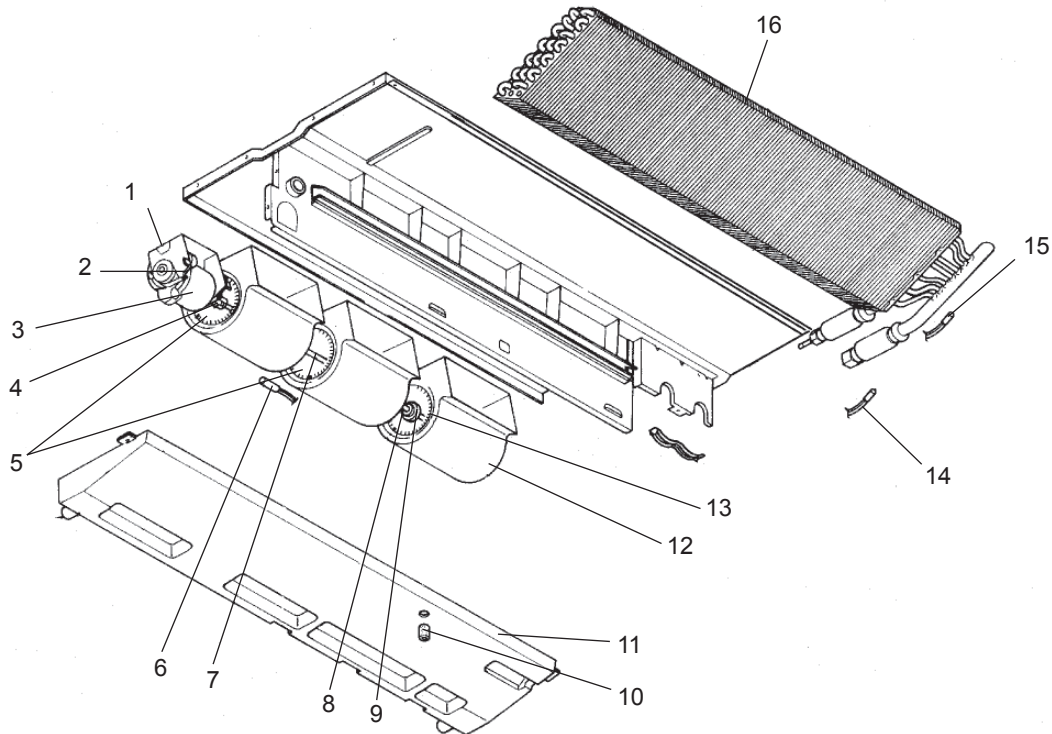
PCA-A24GA₁ PCA-A30GA₁ PCA-A36GA₁ PCA-A42GA₁PCA-A24GA₂ PCA-A30GA₂ PCA-A36GA₂ PCA-A42GA₂

No.	RoHS	Parts No.	Parts Name	Specifications	Q'ty/set		Remarks (Drawing No.)	Wiring Diagram Symbol	Recom- mended Q'ty
					PCA-A 24/30 GA ₁ , GA ₂	36/42			
1	G	R01 30J 130	MOTOR LEG		1				
	G	R01 32J 130	MOTOR LEG			1			
2	G	R01 45E 126	PIECE(MOTOR)		1	1			
3	G	T7W 40J 762	FAN MOTOR	D09C4P70MS	1			MF	
	G	T7W E31 762	FAN MOTOR	D10C4P90MS		1		MF	
4	G	R01 800 116	SHAFT JOINT		1	1			
5	G	R01 E17 114	SIROCCO FAN		2				
	G	R01 E19 114	SIROCCO FAN			2			
6	G	R01 H08 202	ROOM TEMPERATURE THERMISTOR		1	1		TH1	
7	G	R01 30J 100	SHAFT		1	1			
8	G	R01 E02 103	SLEEVE BEARING		1	1			
	G	R01 30J 145	BEARING SUPPORT		1				
9	G	R01 36J 145	BEARING SUPPORT			1			
	G	R01 18J 524	DRAIN PLUG		1	1			
10	G	T7W E30 529	DRAIN PAN ASSY		1				
	G	T7W E31 529	DRAIN PAN ASSY			1			
11	G	R01 18J 110	CASING		3				
	G	R01 19J 110	CASING			3			
12	G	R01 E15 114	SIROCCO FAN		1				
	G	R01 E20 114	SIROCCO FAN			1			
13	G	R01 H10 202	LIQUID PIPE TEMPERATURE THERMISTOR		1	1		TH2	
	G	R01 H09 202	COND/EVA TEMPERATURE THERMISTOR		1	1		TH5	
14	G	T7W H23 480	HEAT EXCHANGER		1				
	G	T7W H24 480	HEAT EXCHANGER			1			

STRUCTURAL PART

PCA-A24GA₁
 PCA-A30GA₁
 PCA-A36GA₁
 PCA-A42GA₁
 PCA-A24GA₂
 PCA-A30GA₂
 PCA-A36GA₂
 PCA-A42GA₂

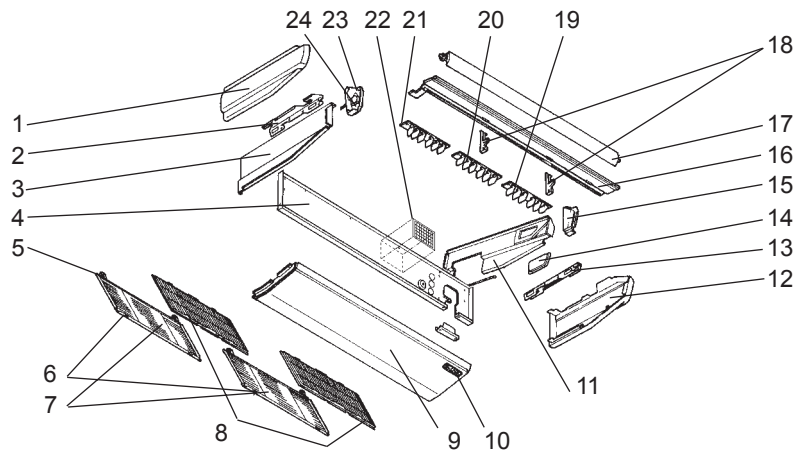

Part numbers that are circled are not shown in the figure.

No.	ROHS	Parts No.	Parts Name	Specifications	Q'ty/set				Remarks (Drawing No.)	Wiring Diagram Symbol	Recom- mended Q'ty
					PCA-A						
					24/30	36/42	24/30	36/42			
GA ₁		GA ₂									
1	G	R01 18J 662	LEFT SIDE PANEL		1		1				
	G	R01 36J 662	LEFT SIDE PANEL			1	1				
2	G	R01 18J 809	LEFT LEG		1	1	1	1			
3	G	T7W E02 666	S.PLATE-L		1		1				
	G	T7W E03 666	S.PLATE-L			1		1			
4	G	T7W E07 676	REAR PANEL		1		1				
	G	T7W E08 676	REAR PANEL			1		1			
5	G	R01 18J 061	GRILLE HINGE		4	4	4	4			
6	G	R01 19J 054	GRILLE CATCH		4	4	4	4			
7	G	R01 19J 691	GRILLE ASSY		2	2	2	2			
8	G	R01 A29 500	L.L FILTER		2	2	2	2			
9	G	R01 30J 669	UNDER PANEL		1	1	1	1			
10	G	T7W E02 070	W.BOARD CASE		1	1	1	1			
	G	T7W E03 665	S.PLATE-R		1		1				
11	G	T7W E04 665	S.PLATE-R			1		1			
	G	R01 18J 661	RIGHT SIDE PANEL		1		1				
12	G	R01 36J 661	RIGHT SIDE PANEL			1		1			
	G	R01 18J 808	RIGHT LEG		1	1	1	1			
14	G	T7W E10 668	SERVICE PANEL		1		1				
	G	T7W E11 668	SERVICE PANEL			1		1			
15	G	R01 18J 067	RIGHT SIDE BOX		1		1				
	G	R01 36J 067	RIGHT SIDE BOX			1		1			
16	G	T7W E08 651	FRONT PANEL		1		1				
	G	T7W E09 651	FRONT PANEL			1		1			
17	G	R01 30J 002	AUTO VANE		1		1				
	G	R01 E14 002	AUTO VANE			1		1			
18	G	R01 E02 033	VANE SUPPORT		2		2				
	G	R01 E03 033	VANE SUPPORT			2		2			
19	G	R01 38J 085	G.V ASSY-6R		1	1	1	1			
20	G	R01 38J 087	G.V ASSY-6C		1	1	1	1			
21	G	R01 38J 086	G.V ASSY-6L		1	1	1	1			
22	G	T7W E03 501	AIR FILTER		1		1				
	G	T7W E04 501	AIR FILTER			1		1			
23	G	R01 18J 068	LEFT SIDE BOX		1		1				
	G	R01 E01 068	LEFT SIDE BOX			1		1			
24	G	R01 E10 223	VANE MOTOR		1		1			MV	
	G	R01 E12 223	VANE MOTOR			1		1		MV	
25	G	R01 18J 523	JOINT SOCKET		1	1	1	1			
26	G	T7W E01 072	DRAIN HOSE COVER		1	1					
	G	R01 18J 072	DRAIN HOSE COVER				1	1			

ELECTRICAL PARTS

PCA-A24GA₁ PCA-A30GA₁ PCA-A36GA₁ PCA-A42GA₁
 PCA-A24GA₂ PCA-A30GA₂ PCA-A36GA₂ PCA-A42GA₂

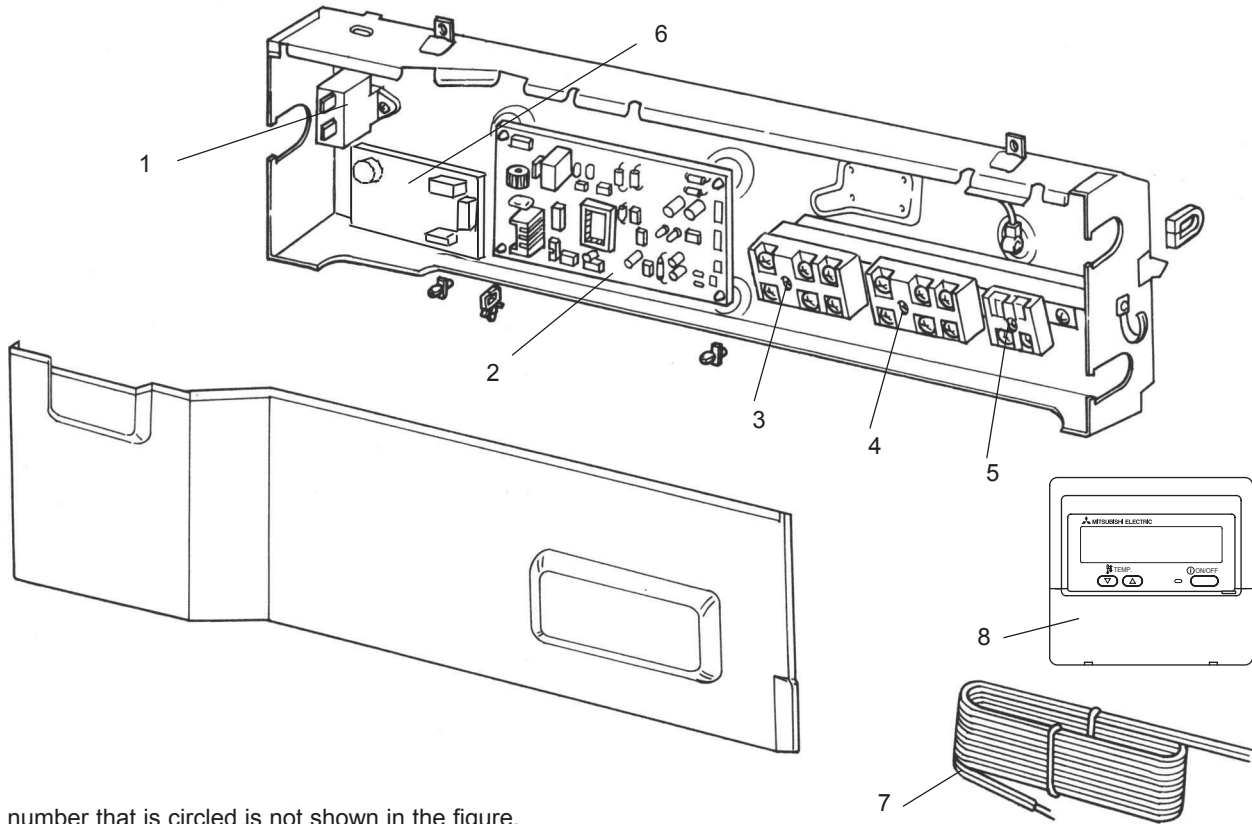

Part number that is circled is not shown in the figure.

No.	RoHS	Parts No.	Parts Name	Specifications	Q'ty/ set				Remarks (Drawing No.)	Wiring Diagram Symbol	Recom- mended Q'ty
					PCA-A						
					24/30 GA ₁	36/42	24/30 GA ₂	36/42			
1	G	T7W E18 255	CAPACITOR	4 μ F 440V	1		1			C	
	G	T7W E19 255	CAPACITOR	5 μ F 440V		1		1		C	
2	G	T7W E56 310	INDOOR CONTROLLER BOARD		1	1				I.B	
	G	T7W E70 310	INDOOR CONTROLLER BOARD				1	1		I.B	
3	G	T7W E41 716	TERMINAL BLOCK	3P(L1,L2,GR)	1	1				TB2	
4	G	R01 E18 246	TERMINAL BLOCK	3P(S1,S2,S3)	1	1	1	1		TB4	
5	G	R01 E21 246	TERMINAL BLOCK	2P(1,2)	1	1				TB5	
	G	T7W E46 716	TERMINAL BLOCK	2P(1,2)			1	1		TB5	
6	G	T7W E35 313	POWER BOARD		1	1	1	1		P.B	
7	G	T7W A01 305	REMOTE CONTROLLER CORD	10m 33ft	1	1	1	1			
8	G	T7W E14 713	REMOTE CONTROLLER	PAR-21MAA	1	1	1	1		R.B	
⑨	G	R01 E06 239	FUSE	6.3A 250V	1	1	1	1		FUSE	

Mr. SLIM™

 **MITSUBISHI ELECTRIC CORPORATION**

HEAD OFFICE : TOKYO BLDG., 2-7-3, MARUNOUCHI, CHIYODA-KU, TOKYO 100-8310, JAPAN

©Copyright 2006 MITSUBISHI ELECTRIC ENGINEERING CO., LTD.
Distributed in Oct. 2007 No.OC368 REVISED EDITION-C PDF 9
Distributed in Jun. 2007 No.OC368 REVISED EDITION-B PDF 9
Distributed in Aug. 2006 No.OC368 REVISED EDITION-A PDF 9
Distributed in Feb. 2006 No.OC368 PDF 10
Made in Japan

New publication, effective Oct. 2007
Specifications subject to change without notice.