

TECHNICAL & SERVICE MANUAL

<Outdoor unit>

[Model Name]

[Service Ref.]

MXZ-SM36NAM

MXZ-SM36NAM-U1

MXZ-SM48NAM

MXZ-SM48NAM-U1

MXZ-SM60NAM

MXZ-SM60NAM-U1

MXZ-SM36NAMHZ

MXZ-SM36NAMHZ-U1

MXZ-SM42NAMHZ

MXZ-SM42NAMHZ-U1

MXZ-SM48NAMHZ

MXZ-SM48NAMHZ-U1

Revision:

- Some descriptions have been revised in REVISED EDITION-B.

OCH789A is void.

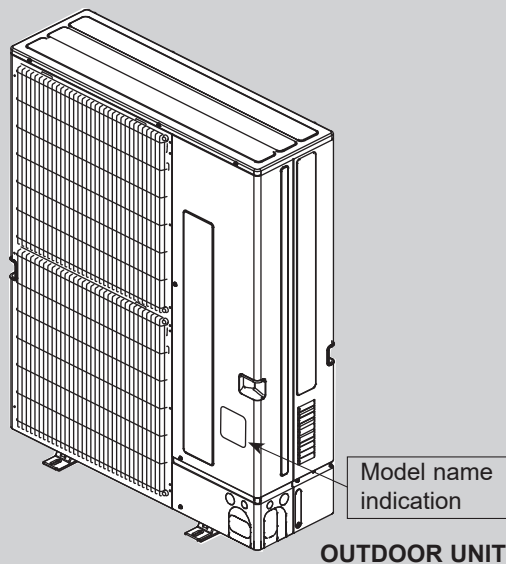

CONTENTS

1. SAFETY PRECAUTION	2
2. OVERVIEW OF UNITS	5
3. SPECIFICATIONS	11
4. DATA	14
5. OUTLINES AND DIMENSIONS	36
6. WIRING DIAGRAM	37
7. NECESSARY CONDITIONS FOR SYSTEM CONSTRUCTION	40
8. TROUBLESHOOTING	55
9. ELECTRICAL WIRING	134
10. REFRIGERANT PIPING TASKS	140
11. DISASSEMBLY PROCEDURE	148

PARTS CATALOG (OCB789)

1

SAFETY PRECAUTION

1-1. ALWAYS OBSERVE FOR SAFETY

Before obtaining access to terminal, all supply circuit must be disconnected.

Preparation before the repair service

- Prepare the proper tools.
- Prepare the proper protectors.
- Provide adequate ventilation.
- After stopping the operation of the air conditioner, turn off the power-supply breaker.
- Discharge the condenser before the work involving the electric parts.

Precautions during the repair service

- Do not perform the work involving the electric parts with wet hands.
- Do not pour water into the electric parts.
- Do not touch the refrigerant.
- Do not touch the hot or cold areas in the refrigerating cycle.
- When the repair or the inspection of the circuit needs to be done without turning off the power, exercise great caution not to touch the live parts.
- When opening or closing the valve below freezing temperatures, refrigerant may spurt out from the gap between the valve stem and the valve body, resulting in injuries.

1-2. CAUTIONS RELATED TO NEW REFRIGERANT

Caution for units utilizing refrigerant R410A

Use new refrigerant pipes.

Avoid using thin pipes.

Make sure that the inside and outside of refrigerant piping is clean and it has no contaminants such as sulfur, oxides, dirt, shaving particles, etc., which are hazard to refrigerant cycle. In addition, use pipes with specified thickness.

Contamination inside refrigerant piping can cause deterioration of refrigerant oil, etc.

Follow the instructions below to prevent abrasive components contained in sandpaper and cutting tools from entering the refrigerant circuit because those components can cause failures of the compressor and valves.

- To deburr pipes, use a reamer or other deburring tools, not sandpaper.
- To cut pipes, use a pipe cutter, not a grinder or other tools that use abrasive materials.
- When cutting or deburring pipes, do not allow cutting chips or other foreign matters to enter the pipes.
- If cutting chips or other foreign matters enter pipes, wipe them off the inside of the pipes.

Store the piping indoors, and keep both ends of the piping sealed until just before brazing. (Leave elbow joints, etc. in their packaging.)

If dirt, dust or moisture enters into refrigerant cycle, that can cause deterioration of refrigerant oil or malfunction of compressor.

Use a vacuum pump with a reverse flow check valve.

Vacuum pump oil may flow back into refrigerant cycle and that can cause deterioration of refrigerant oil, etc.

Use the following tools specifically designed for use with R410A refrigerant.

The following tools are necessary to use R410A refrigerant.

Tools for R410A	
Gauge manifold	Flare tool
Charge hose	Size adjustment gauge
Gas leak detector	Vacuum pump adaptor
Torque wrench	Electronic refrigerant charging scale

Handle tools with care.

If dirt, dust or moisture enters into refrigerant cycle, that can cause deterioration of refrigerant oil or malfunction of compressor.

Do not use a charging cylinder.

If a charging cylinder is used, the composition of refrigerant will change and the efficiency will be lowered.

Ventilate the room if refrigerant leaks during operation. If refrigerant comes into contact with a flame, poisonous gases will be released.

The refrigerant oil applied to flare and flange connections must be ester oil, ether oil or alkylbenzene oil in a small amount.

If large amount of mineral oil enters, that can cause deterioration of refrigerant oil, etc.

Charge refrigerant from liquid phase of gas cylinder.

If the refrigerant is charged from gas phase, composition change may occur in refrigerant and the efficiency will be lowered.

Do not use refrigerant other than R410A.

If other refrigerant (R22, etc.) is used, chlorine in refrigerant can cause deterioration of refrigerant oil, etc.

Use the specified refrigerant only.

Never use any refrigerant other than that specified.

Doing so may cause a burst, an explosion, or fire when the unit is being used, serviced, or disposed of. Correct refrigerant is specified in the manuals and on the spec labels provided with our products.

We will not be held responsible for mechanical failure, system malfunction, unit breakdown or accidents caused by failure to follow the instructions.

Do not pump down the system when a gas leak has been detected.

The intake of air or other gases causes abnormally high pressure in the refrigeration cycle, which may cause explosion or injury.

[1] Cautions for service

- (1) Perform service after recovering the refrigerant left in unit completely.
- (2) Do not release refrigerant in the air.
- (3) After completing service, charge the cycle with specified amount of refrigerant.
- (4) If moisture or foreign matter might have entered the refrigerant piping during service, ensure to remove them.

[2] Additional refrigerant charge

When charging directly from cylinder

- (1) Check that cylinder for R410A on the market is a syphon type.
- (2) Charging should be performed with the cylinder of syphon stood vertically. (Refrigerant is charged from liquid phase.)

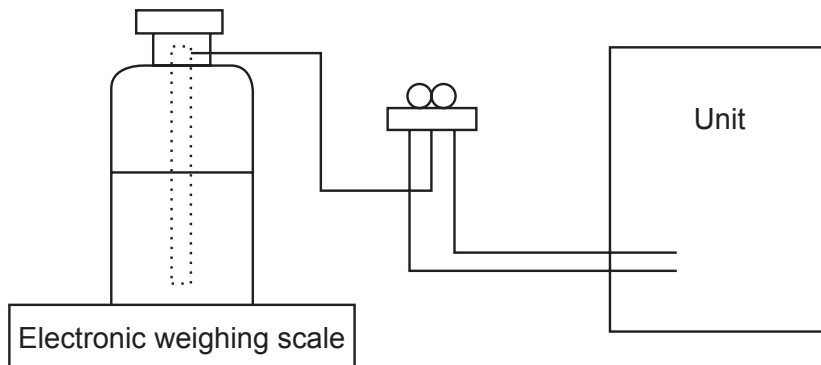

[3] Service tools

Use the below service tools as exclusive tools for R410A refrigerant.

No.	Tool name	Specifications
1	Gauge manifold	· Only for R410A
		· Use the existing fitting specifications. (UNF1/2)
		· Use high-tension side pressure of 768.7 PSIG [5.3 MPa.G] or over.
2	Charge hose	· Only for R410A
		· Use pressure performance of 738.2 PSIG [5.09MPa.G] or over.
3	Electronic weighing scale	—
4	Gas leak detector	· Use the detector for R134a, R407C or R410A.
5	Adaptor for reverse flow check	· Attach on vacuum pump.
6	Refrigerant charge base	—
7	Refrigerant cylinder	· Only for R410A · Top of cylinder (Pink)
		· Cylinder with syphon
8	Refrigerant recovery equipment	—

Cautions for refrigerant piping work

New refrigerant R410A is adopted for replacement inverter series. Although the refrigerant piping work for R410A is same as for R22, exclusive tools are necessary so as not to mix with different kind of refrigerant. Furthermore as the working pressure of R410A is 1.6 times higher than that of R22, their sizes of flared sections and flare nuts are different.

1 Thickness of pipes

Because the working pressure of R410A is higher compared to R22, be sure to use refrigerant piping with thickness shown below. (Never use pipes of 7/256 in [0.7 mm] or below.)

Diagram below: Piping diameter and thickness

Nominal dimensions (in)	Outside diameter (mm)	Thickness : in [mm]	
		R410A	R22
1/4	6.35	1/32 [0.8]	1/32 [0.8]
3/8	9.52	1/32 [0.8]	1/32 [0.8]
1/2	12.70	1/32 [0.8]	1/32 [0.8]
5/8	15.88	5/128 [1.0]	5/128 [1.0]
3/4	19.05	5/128 [1.0]*	5/128 [1.0]

*Use 1/2 H or H pipes.

2 Dimensions of flare cutting and flare nut

The component molecules in HFC refrigerant are smaller compared to conventional refrigerants. In addition to that, R410A is a refrigerant, which has higher risk of leakage because its working pressure is higher than that of other refrigerants. Therefore, to enhance airtightness and strength, flare cutting dimension of copper pipe for R410A has been specified separately from the dimensions for other refrigerants as shown below. The dimension B of flare nut for R410A also has partly been changed to increase strength as shown below. Set copper pipe correctly referring to copper pipe flaring dimensions for R410A below. For 1/2 and 5/8 inch pipes, the dimension B changes. Use torque wrench corresponding to each dimension.

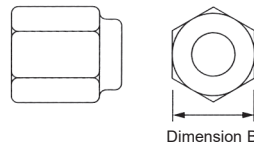
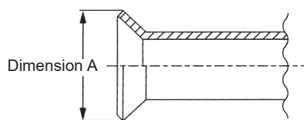

Flare cutting dimensions

Unit : in [mm]

Nominal dimensions (in)	Outside diameter (mm)	Dimension A ($\frac{3}{4}$)	
		R410A	R22
1/4	6.35	11/32-23/64 [9.1]	9.0
3/8	9.52	1/2-33/64 [13.2]	13.0
1/2	12.70	41/64-21/32 [16.6]	16.2
5/8	15.88	49/64-25/32 [19.7]	19.4
3/4	19.05	—	23.3

Flare nut dimensions

Unit: in [mm]

Nominal dimensions (in)	Outside diameter (mm)	Dimension B	
		R410A	R22
1/4	6.35	43/64 [17.0]	17.0
3/8	9.52	7/8 [22.0]	22.0
1/2	12.70	1-3/64 [26.0]	24.0
5/8	15.88	1-9/64 [29.0]	27.0
3/4	19.05	—	36.0

3 Tools for R410A (The following table shows whether conventional tools can be used or not.)

Tools and materials	Use	R410A tools	Can R22 tools be used?	Can R407C tools be used?
Gauge manifold	Air purge, refrigerant charge and operation check	Tool exclusive for R410A	×	×
Charge hose	Refrigerant recovery	Tool exclusive for R410A	×	×
Gas leak detector	Gas leak check	Tool for HFC refrigerant	×	○
Refrigerant recovery equipment	Refrigerant recovery	Tool exclusive for R410A	×	×
Refrigerant cylinder	Refrigerant charge	Tool exclusive for R410A	×	×
Applied oil	Apply to flared section	Ester oil, ether oil and alkylbenzene oil (minimum amount)	×	Ester oil, ether oil: ○ Alkylbenzene oil: minimum amount
Safety charger	Prevent compressor malfunction when charging refrigerant by spraying liquid refrigerant	Tool exclusive for R410A	×	×
Charge valve	Prevent gas from blowing out when detaching charge hose	Tool exclusive for R410A	×	×
Vacuum pump	Vacuum drying and air purge	Tools for other refrigerants can be used if equipped with adopter for reverse flow check	△ (Usable if equipped with adopter for reverse flow)	△ (Usable if equipped with adopter for reverse flow)
Flare tool	Flaring work of piping	Tools for other refrigerants can be used by adjusting flaring dimension	△ (Usable by adjusting flaring dimension)	△ (Usable by adjusting flaring dimension)
Bender	Bend the pipes	Tools for other refrigerants can be used	○	○
Pipe cutter	Cut the pipes	Tools for other refrigerants can be used	○	○
Welder and nitrogen gas cylinder	Weld the pipes	Tools for other refrigerants can be used	○	○
Refrigerant charging scale	Refrigerant charge	Tools for other refrigerants can be used	○	○
Vacuum gauge or thermistor vacuum gauge and vacuum valve	Check the degree of vacuum. (Vacuum valve prevents back flow of oil and refrigerant to thermistor vacuum gauge)	Tools for other refrigerants can be used	○	○
Charging cylinder	Refrigerant charge	Tool exclusive for R410A	×	—

× : Prepare a new tool. (Use the new tool as the tool exclusive for R410A.)

△ : Tools for other refrigerants can be used under certain conditions.

○ : Tools for other refrigerants can be used.

2-1. Auxiliary HEATING ON/OFF CONTROL SET-UP

(1) Auxiliary heating operation controls another heat source that depends on the main system's operations, which means the interlock operation shown in "b)" will be possible.

a) Indoor unit must be R410A UL model for this function to operate.

b) Different Indoor unit applications that can be applied:

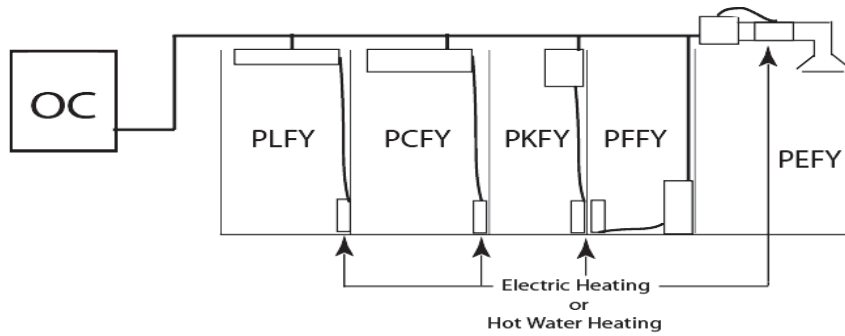

(2) **Outdoor unit DIPSW5-4 for auxiliary heating control:**

Set DIPSW5-4 when power is turned off at unit.

OFF: Disable auxiliary Heating Function (Initial setting)

ON : Enable auxiliary Heating Function

(3) **Determine required indoor fan speed during defrost mode:**

To set the fan speed, see the chapter referring to heater control in the indoor unit's Technical & Service Manual.

(4) Determine fan speed setting during indoor thermo-OFF conditions:

- a) These settings are done within Indoor DIPSW1-7 and DIPSW1-8, see chart below for options.
- b) Recommended SW1-7 OFF and SW1-8 ON will determine airflow based on "Setting on the remote controller".

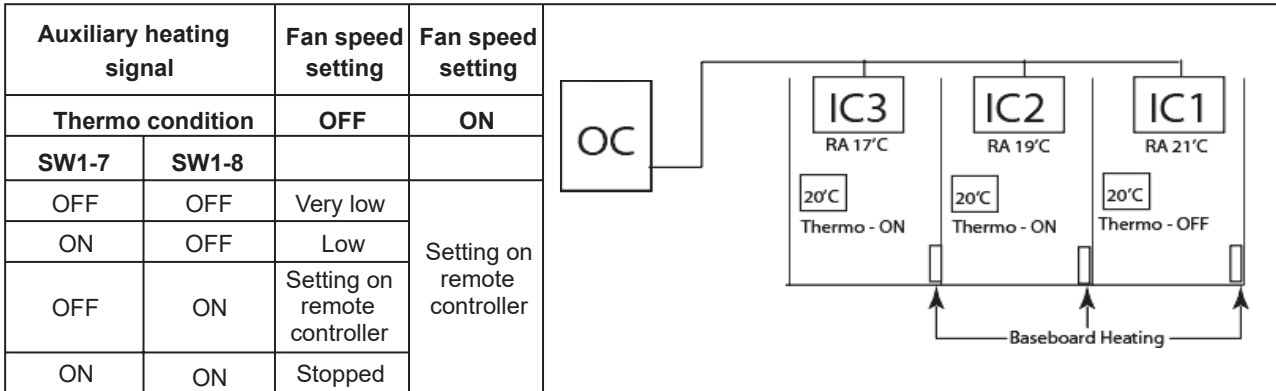

(5) Setting outdoor unit and auxiliary heat switch over temperatures

When the DIPSW 5-4 is set to "ON", the outdoor unit and the contact output operates as shown below.

- a) Outdoor default setting and operations are shown below:

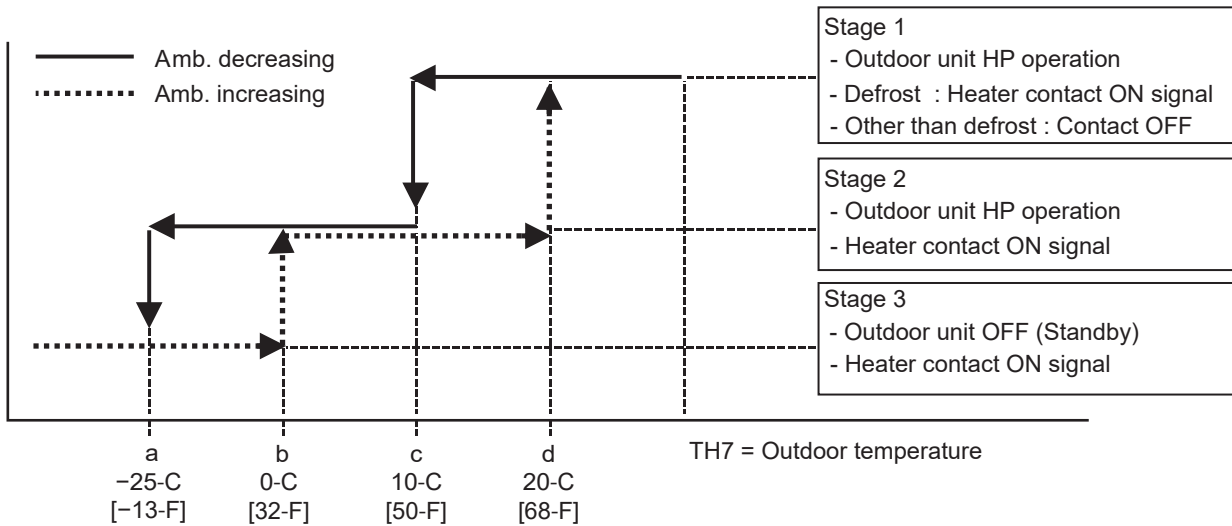

When the set temperature ranges overlap, the previously set pattern (1, 2 or 3) has a priority. The stage 1 has the highest priority, 2 the second and then 3.

- b) Based on above chart listed the sequence of operation on "On ambient decrease"
 - Stage 1: (TH7 = > 50°F [10°C]): the outdoor unit runs in HP mode.
 - Stage 2: (TH7 = 50 to -13°F [10 to -25°C]): the outdoor unit runs in HP mode with auxiliary heating.
 - Stage 3: (TH7 = < -13°F [-25°C]): Auxiliary heating only (Outdoor unit is OFF).
- c) Based on above chart listed the sequence of operation on "On ambient increase"
 - Stage 3: (TH7 = < 32°F [0°C]): Auxiliary heating only (Outdoor unit is OFF).
 - Stage 2: (TH7 = > 32 to 68°F [0 to 20°C]): Auxiliary heating with outdoor unit in HP mode.
 - Stage 1: (TH7 = > 68°F [20°C]): Outdoor unit in HP mode only.

(6) Locally procured wiring

A basic connection method is shown.

(i.e. interlocked operation with the electric heater with the fan speed setting on high)

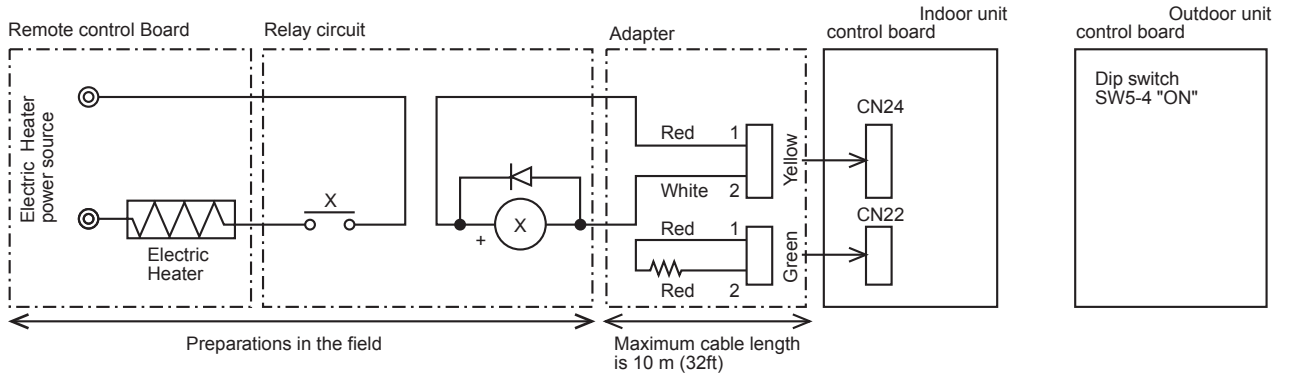

For relay X use the specifications given below operation coil

Rated voltage: 12 V DC

Power consumption: 0.9W or less

*Use the diode that is recommended by the relay manufacturer at both ends of the relay coil.

The length of the electrical wiring for the PAC-YU24HT is 2 meters (6-1/2 ft)

To extend this length, use sheathed 2-core cable.

Control cable type: CVV, CVS, CPEV, or equivalent.

Cable size: 0.5 mm² to 1.25 mm² (AWG22 to AWG16)

Do not extend the cable more than 10 meters (32 ft).

Recommended circuit

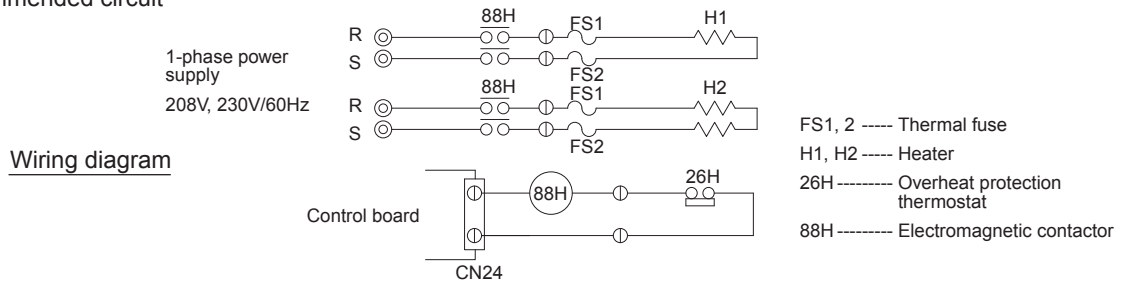

2-2. SYSTEM CONSTRUCTION

Outdoor unit		4HP	4.5HP	5HP	7HP
		MXZ-SM36NAM-U1 MXZ-SM36NAMHZ-U1	MXZ-SM42NAMHZ-U1	MXZ-SM48NAM-U1 MXZ-SM48NAMHZ-U1	MXZ-SM60NAM-U1
Applicable indoor unit	Capacity	Type 04 to Type 36	Type 04 to Type 54		Type 04 to Type 72
	Max. No. of units	11 units	12 units		
Total system capacity range		50 to 130% of outdoor unit capacity			

	CMY-Y62-G-E	CMY-Y64-G-E	CMY-Y68-G-E
Branching pipe components	Branch header (2 branches)	Branch header (4 branches)	Branch header (8 branches)

Model	Cassette Ceiling				Ceiling Concealed				Wall Mounted				Ceiling Suspended	Floor standing		Multi-position air handling unit
	4-way flow	2 by 2		1-way flow	PEFY-P				PKFY-P			PCFY-P	Exposed	Concealed		
	PLFY-EP	PLFY-P	PLFY-P	PMFY-P	NMAU	NMSU-E	NMHU-E	NMSU-E	NBMU-E	NHMU-E	NKMU-E	NLMU-E	NKMU-E	PCFY-P	PFFY-P	
Capacity	NEMU-E	NCMU-E	NFMU-E	NBMU-E	NMAU	NMSU-E	NMHU-E	NMSU-E	NBMU-E	NHMU-E	NKMU-E	NLMU-E	NKMU-E	NEMU-E	NRMU-E	NAMU-E
04	-	-	-	-	-	-	-	-	-	-	-	○	-	-	-	-
05	-	-	○	-	-	-	-	-	-	-	-	-	-	-	-	-
06	-	-	-	○	○	○	-	-	○	-	-	○	-	○	○	-
08	-	○	○	○	○	○	-	-	-	○	-	○	-	○	○	○
12	○	○	○	○	○	○	-	-	-	○	-	○	-	○	○	○
15	○	○	○	○	○	○	○	-	-	○	-	○	○	○	○	-
18	○	-	○	-	○	○	○	-	-	○	-	○	-	○	○	○
24	○	-	-	-	○	○	○	-	-	-	○	-	○	○	○	○
27	-	-	-	-	○	-	○	-	-	-	-	-	-	-	-	-
30	○	-	-	-	○	-	○	-	-	-	○	-	○	-	-	○
36	○	-	-	-	○	-	○	-	-	-	-	-	○	-	-	○
48	○	-	-	-	○	-	○	-	-	-	-	-	-	-	-	○
54	-	-	-	-	○	-	○	-	-	-	-	-	-	-	-	○
72	-	-	-	-	-	-	-	○*	-	-	-	-	-	-	-	-

* Only MXZ-SM60 is connectable.

-: Not connectable
○: Connectable

Remote controller	Name	M-NET remote controller	MA remote controller
	Model number	PAR-F27MEA-E PAR-U01MEDU	PAR-21MAA, PAR-40MAA
	Functions	<ul style="list-style-type: none"> A handy remote controller for use in conjunction with the Melans centralized management system. Addresses must be set. 	<ul style="list-style-type: none"> Addresses setting is not necessary.

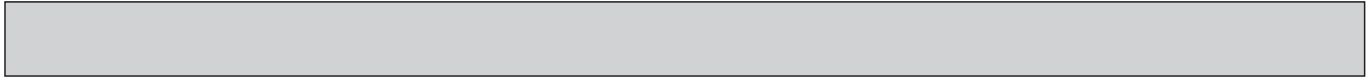

Outdoor unit		MXZ-SM36NAM-U1 MXZ-SM36NAMHZ-U1		MXZ-SM42NAMHZ-U1	MXZ-SM48NAM-U1 MXZ-SM48NAMHZ-U1	MXZ-SM60NAM-U1
		4HP		4.5HP	5HP	7HP
Rated capacity (kBtu/h)	Cooling	36	42	48	60	
	Heating	42	48	54	66	
	Refrigerant	R410A				
Connectable indoor unit	Capacity class	Type 06 to Type 36				
	Caution: Never connect the indoor unit which rated capacity exceeds 36 kBtu/h (Type 36).					
	Max. No. of units	4 units	5 units	8 units	8 units	
Total system capacity range		33 to 130% of outdoor unit capacity (12 to 46.8 kBtu/h)	29 to 130% of outdoor unit capacity (12 to 54.6 kBtu/h)	25 to 130% of outdoor unit capacity (12 to 62.4 kBtu/h)	20 to 130% of outdoor unit capacity (12 to 78 kBtu/h)	
Connectable branch box	Number of units	1 or 2 units				



Connectable indoor unit lineups (Heat pump inverter type)									
Model type	Model name	Capacity class [kBtu/h]							
		06	09	12	15	18	24	30	36
Deluxe Wall-mounted	MSZ-FH06/09/12/15NA, 18NA2 MSZ-FS06/09/12/15/18NA	●	●	●	●	●			
Designer	MSZ-EF09/12/15/18NA(W/B/S)		●	●	●	●			
Standard Wall-mounted	MSZ-GL06/09/12/15/18/24NA	●	●	●	●	●	●		
Low static ducted ² ³	SEZ-KD09/12/15/18NA		●	●	●	●			
P-series mid static ducted ² ³	PEAD-A09/12/15/18/24/30/36AA7		●	●	●	●	●	●	●
1-way cassette	MLZ-KP09/12/18NA(2)		●	●	●	●			
P-series 22*22 4-way cassette	SLZ-KF09/12/15NA		●	●	●				
P-series 33*33 4-way cassette	PLA-A12/18/24/30/36EA7 ⁴			●		●	●	●	●
Floor standing	MFZ-KJ09/12/15/18NA		●	●	●	●			
Standard Multi-position air handler ^{*1}	SVZ-KP12/18/24/30/36NA			●		●	●	●	●



Branch box	PAC-MKA52BC	PAC-MKA32BC
Number of branches (Indoor unit that can be connected)	5 branches (MAX. 5 units)	3 branches (MAX. 3 units)

Note: A maximum of 2 branch boxes can be connected to 1 outdoor unit.



2- branch pipe (joint): Optional parts								
In the case of using 1- branch box	No need							
In the case of using 2- branch boxes	<table border="1"> <tr> <th>Model name</th> <th>Connection method</th> </tr> <tr> <td>MSDD-50AR-E</td> <td>flare</td> </tr> <tr> <td>MSDD-50BR-E</td> <td>brazing</td> </tr> </table>	Model name	Connection method	MSDD-50AR-E	flare	MSDD-50BR-E	brazing	Select a model according to the connection method.
Model name	Connection method							
MSDD-50AR-E	flare							
MSDD-50BR-E	brazing							



Option	Optional accessories for indoor units and outdoor units are available.
--------	--

^{*1} When connecting a multi-position unit(s), set additional constraints as follows. For connections other than those specified below, consult your dealer.

● **Models other than MXZ-SM60NAM** (For each connected branch box)

● **MXZ-SM60NAM** (For each connected branch box)

Number of connecting multi-position unit	Constraints
2	Any indoor units other than ducted units are not connectable.
1	<ul style="list-style-type: none"> The total system wide capacity should be 130% or below including the ducted unit. Only 1 ducted unit can be included in the connection.

Number of connecting multi-position unit	Constraints
2	Any indoor units other than ducted unit are not connectable.
1	<ul style="list-style-type: none"> The total system wide capacity should be 100% or below including the ducted unit. Only 1 ducted unit can be included in the connection.

^{*2} For MXZ-SM60NAM; When connecting the SEZ and PEAD-series units, the total system wide capacity per 1 branch box should be 100% or below including the ducted units. (Only if connecting to branch box)

^{*3} When not outside units 60: A branch box can connect to maximum 3 of the ducted units. When connecting with 3 of the ducted units per 1 branch box, other indoor units cannot be connected.
When outside units 60: A branch box can connect to maximum 2 of the ducted units. When connecting with 1 and over 1 of the ducted units, the total ability including of the ducted units is 100% and below 100%.

^{*4} When the system includes 1 unit of ducted units, the number of the maximum connectable indoor units is decreased as follows:
3 for MXZ-SM36NAM(HZ), 4 for MXZ-SM42NAMHZ, and 6 for MXZ-SM48NAM(HZ) and MXZ-SM60NAM

2-3. SYSTEM SPECIFICATIONS

(1) Outdoor Unit

Service Ref.		MXZ-SM36NAM-U1 MXZ-SM36NAMHZ-U1	MXZ-SM42NAMHZ-U1	MXZ-SM48NAM-U1 MXZ-SM48NAMHZ-U1	MXZ-SM60NAM-U1
Capacity	Cooling (kBtu/h)	36	42	48	60
	Heating (kBtu/h)	42	48	54	66
Compressor (kW)		2.8	2.9	3.4	3.9

Cooling/Heating capacity indicates the maximum value at operation under the following condition.

Cooling	Indoor	D.B. 80°F/W.B. 67°F: [D.B. 26.7°C/W.B. 19.4°C]
	Outdoor	D.B. 95°F/W.B. 75°F: [D.B. 35°C/W.B. 23.9°C]
Heating	Indoor	D.B. 70°F/W.B. 60°F: [D.B. 21.1°C/W.B. 15.6°C]
	Outdoor	D.B. 47°F/W.B. 43°F: [D.B. 8.3°C/W.B. 6.1°C]

(2) Method for identifying

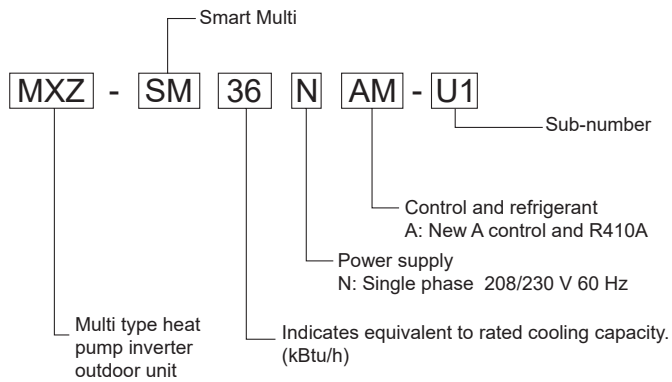

3

SPECIFICATIONS

Service Ref.			MXZ-SM36NAM-U1			MXZ-SM48NAM-U1			
Indoor type			Non-Ducted	Mix	Ducted	Non-Ducted	Mix	Ducted	
M-metric (AHR1210/240-2017)	Cooling	Capacity Rated*1	Btu/h	36,000	36,000	36,000	48,000	48,000	48,000
		Rated power consumption*1	W	2,400	2,610	2,855	3,665	3,930	4,245
		Current input (208/230V)	A	11.7/10.6	12.7/11.5	13.9/12.6	17.9/16.2	19.2/17.3	20.7/18.7
		EER	Btu/h/W	15.00	13.80	12.60	13.10	12.20	11.30
		SEER	-	23.00	20.70	18.30	23.00	19.80	16.50
	Heating	Capacity Rated 47°F*1	Btu/h	42,000	42,000	42,000	54,000	54,000	54,000
		Capacity Max. 17°F*2	Btu/h	36,000	36,000	36,000	43,000	43,000	43,000
		Capacity Max. 5°F	Btu/h	29,000	29,000	29,000	36,800	36,800	36,800
		Rated power consumption 47°F*1	W	3,080	3,200	3,325	3,955	4,335	4,795
		Current input (208/230V)	A	15.0/13.6	15.6/14.1	16.2/14.7	19.3/17.5	21.2/19.1	23.4/21.2
M1-metric (AHR1210/240-2023)	Cooling	Capacity Rated*1	Btu/h	36,000	36,000	36,000	48,000	48,000	48,000
		Rated power consumption*1	W	2,400	2,740	3,190	3,665	4,090	4,615
		Current input (208/230V)	A	11.7/10.6	13.4/12.1	15.6/14.1	17.9/16.2	20.0/18.1	22.5/20.4
		EER2	Btu/h/W	15.00	13.15	11.30	13.10	11.75	10.40
		SEER2	-	23.00	19.30	15.60	23.00	18.85	14.70
	Heating	Capacity Rated 47°F*1	Btu/h	42,000	42,000	42,000	54,000	54,000	54,000
		Capacity Max. 17°F*2	Btu/h	36,000	36,000	36,000	43,000	43,000	43,000
		Capacity Max. 5°F	Btu/h	29,000	29,000	29,000	36,800	36,800	36,800
		Rated power consumption 47°F*1	W	3,080	3,330	3,620	3,960	4,400	4,950
		Current input (208/230V)	A	15.0/13.6	16.3/14.7	17.7/16.0	19.3/17.5	21.5/19.4	24.2/21.8
Power supply			1 Phase 208/230 V, 60 Hz						
Breaker Size/Max. fuse size			30 A/40 A (When power is supplied separately), 40 A/50 A (When power is supplied from the outdoor unit)						
Min. circuit ampacity			29 A (When power is supplied separately), 35 A (When power is supplied from the outdoor unit)						
Indoor unit connectable	Total capacity		50 to 130% of outdoor unit capacity						
	Model/Quantity*3	CITY MULTI	04 - 36/11			04 - 54/12			
Sound pressure level (measured in anechoic room)	Branch box		06 - 36/4			06 - 36/8			
	dB <A>		49/53			51/54			
Refrigerant piping diameter	Liquid pipe	inch (mm)	ø3/8 (9.52)						
	Gas pipe	inch (mm)	ø5/8 (15.88)						
Fan	Type × Quantity		Propeller fan × 2						
	Airflow rate	m³/min	110						
		L/s	1,834						
		cfm	3,885						
	Control, Driving mechanism		DC control						
	Motor output	kW	0.074 + 0.074						
External static press.		0							
Compressor	Type × Quantity		Scroll hermetic compressor × 1						
	Manufacture		Mitsubishi Electric Corporation						
	Starting method		Inverter						
	Motor output	kW	2.8			3.4			
	Case heater	kW	0						
	Lubricant		FV50S 78oz. (2.3L)						
External finish			Galvanized Steel Sheet <Munsell 3Y 7.8/ 1.1>						
External dimension H × W × D		mm	1,338 × 1,050 × 330 (+25)						
		inch	52-11/16 × 41-11/32 × 13 (+1)						
Protection devices	High pressure protection		HP switch						
	Inverter circuit (COMP./FAN)		Overcurrent detection, Overheat detection (Heat sink thermistor)						
	Compressor protection		Compressor thermo, Overcurrent detection						
	Fan motor protection		Overheating/Voltage protection						
Refrigerant	Type × original charge		R410A 10 lbs. 9 oz. (4.8kg)						
	Control		Linear Expansion Valve						
Net weight	lb (kg)		271 (123)						
Heat exchanger			Cross fin and tube						
HIC circuit (HIC: Heat Inter-Changer)			HIC circuit						
Defrosting method			Reversed refrigerant circuit						
Guaranteed operation range		(Cooling)	D.B. 23 to 115°F [D.B.-5 to 46°C] *4*5*6						
		(Heating)	D.B.-13 to 70°F [D.B. -25 to 21°C]						
Remarks			Details on foundation work, duct work, insulation work, electrical wiring, power source switch, and other items shall be referred to the Installation Manual. Because of continuing improvement, above specifications may be subject to change without notice.						

*1 Rating conditions Cooling Indoor : D.B. 80°F/W.B. 67 °F [D.B.26.7°C/W.B. 19.4°C]
 Outdoor : D.B. 95°F [D.B. 35.0°C]
 Heating Indoor : D.B. 70°F [D.B. 21.1°C]
 Outdoor : D.B. 47°F/W.B. 43°F [D.B. 8.3°C/W.B. 6.1°C]
 *2 Conditions Heating Indoor : D.B. 70°F [D.B. 21.1°C]
 Outdoor : D.B. 17°F/W.B. 15°F [D.B. -8.3°C/W.B. -9.4°C]
 *3 It can not be connected mixed CITY MULTI indoor unit and branch box indoor unit.
 *4 D.B. 5 to 115°F [D.B. -15 to 46°C], when an optional Air Outlet Guide is installed.
 However, this condition does not apply to the indoor units listed in *5.
 *5 50 to 115°F (10 to 46°C) D.B.: When connecting PKFY-P06NBMU, PKFY-P08NHMU,
 PKFY-P04/06/08/12NLMU, PFFY-P06/08/12NEMU, and PFFY-P06/08/12NRMU type indoor unit.
 *6 When the temperature is below D.B. 50°F [D.B. 10°C] with branch box system, noise could potentially occur.
 Note: Refer to the indoor unit's service manual for the indoor units specifications.

Conversion formula:	kcal/h = kW × 860
	Btu/h = kW × 3412
	CFM = m³/min × 35.31

M-metric (AHR12/10/240-2017)												
Service Ref.			MXZ-SM36NAMHZ-U1			MXZ-SM42NAMHZ-U1			MXZ-SM48NAMHZ-U1			
Indoor type			Non-Ducted	Mix	Ducted	Non-Ducted	Mix	Ducted	Non-Ducted	Mix	Ducted	
M-metric (AHR12/10/240-2017)	Cooling	Capacity Rated*1	Btu/h	36,000	36,000	36,000	42,000	42,000	42,000	48,000	48,000	48,000
		Rated power consumption*1	W	2,400	2,610	2,855	3,135	3,440	3,820	3,665	3,930	4,245
		Current input (208/230V)	A	11.7/10.6	12.7/11.5	13.9/12.6	15.3/13.8	16.8/15.2	18.6/16.9	17.9/16.2	19.2/17.3	20.7/18.7
		EER	Btu/h/W	15.00	13.80	12.60	13.40	12.20	11.00	12.20	13.10	11.30
		SEER	-	23.00	20.70	18.30	22.00	20.00	18.00	23.00	19.80	16.50
		Capacity Max. 17°F*2	Btu/h	42,000	42,000	42,000	48,000	48,000	48,000	54,000	54,000	54,000
	Heating	Capacity Max. 5°F	Btu/h	42,000	42,000	42,000	48,000	48,000	48,000	54,000	54,000	54,000
		Rated power consumption 47°F*1	W	3,080	3,200	3,325	3,430	3,750	4,140	3,955	4,335	4,795
		Current input (208/230V)	A	15.0/13.6	15.6/14.1	16.2/14.7	16.7/15.1	18.3/16.6	20.2/18.3	19.3/17.5	21.2/19.1	23.4/21.2
		COP 47°F*1	W/W	4.00	3.85	3.70	4.10	3.75	3.40	4.00	3.65	3.30
		HSPF IV / V	-	12.50/10.30	12.10/9.90	11.70/9.50	12.00/9.50	11.50/9.5	11.00/9.50	12.00/9.40	11.50/9.20	11.00/9.00
		Capacity Max. 5°F	Btu/h	42,000	42,000	42,000	48,000	48,000	48,000	54,000	54,000	54,000
M1-metric (AHR12/10/240-2023)	Cooling	Capacity Rated*1	Btu/h	36,000	36,000	36,000	42,000	42,000	42,000	48,000	48,000	48,000
		Rated power consumption*1	W	2,400	2,740	3,190	3,135	3,500	3,965	3,665	4,090	4,615
		Current input (208/230V)	A	11.7/10.6	13.4/12.1	15.6/14.1	15.3/13.8	17.1/15.4	19.4/17.5	17.9/16.2	20.0/18.1	22.5/20.4
		EER2	Btu/h/W	15.00	13.15	11.30	13.40	12.00	10.60	13.10	11.75	10.40
		SEER2	-	23.00	19.30	15.60	21.50	18.85	14.70	23.00	18.85	14.70
		Capacity Max. 17°F*2	Btu/h	42,000	42,000	42,000	48,000	48,000	48,000	54,000	54,000	54,000
	Heating	Capacity Max. 5°F	Btu/h	42,000	42,000	42,000	48,000	48,000	48,000	54,000	54,000	54,000
		Rated power consumption 47°F*1	W	3,080	3,330	3,620	3,435	3,805	4,265	3,960	4,400	4,950
		Current input (208/230V)	A	15.0/13.6	16.3/14.7	17.7/16.0	16.8/15.2	18.6/16.8	20.8/18.8	19.3/17.5	21.5/19.4	24.2/21.8
		COP 47°F*1	W/W	4.00	3.70	3.40	4.10	3.70	3.30	4.00	3.60	3.20
		HSPF2 IV / V	-	12.00/10.65	10.95/9.70	9.90/8.80	11.10/9.80	10.10/9.30	9.10/8.80	11.50/9.80	10.15/9.05	8.80/8.30
		Capacity Max. 5°F	Btu/h	42,000	42,000	42,000	48,000	48,000	48,000	54,000	54,000	54,000
Power supply			1 Phase 208/230 V, 60 Hz									
Breaker Size/Max. fuse size			40 A/40 A (When power is supplied separately), 45 A/50 A (When power is supplied from the outdoor unit)									
Min. circuit ampacity			36 A (When power is supplied separately), 42 A (When power is supplied from the outdoor unit)									
Indoor unit connectable			50 to 130% of outdoor unit capacity									
Total capacity												
Model/Quantity *3			CITY MULTI			04 - 36/11			04 - 54/12			
Branch box			06 - 36/4			06 - 36/5			06 - 36/8			
Sound pressure level (measured in anechoic room)			dB <A>			49/53			50/54			
Refrigerant piping diameter			Liquid pipe			inch (mm)			ø3/8 (9.52)			
			Gas pipe			inch (mm)			ø5/8 (15.88)			
Fan			Type x Quantity			Propeller fan x 2						
			Airflow rate			m³/min			110			
						L/s			1,834			
						cfm			3,885			
			Control, Driving mechanism			DC control						
			Motor output			kW			0.074 + 0.074			
			External static press.			0						
Compressor			Type x Quantity			Scroll hermetic compressor x 1						
			Manufacture			Mitsubishi Electric Corporation						
			Starting method			Inverter						
			Motor output			kW			2.8			
			Case heater			kW			0			
			Lubricant			FV50S 78oz. (2.3L)						
External finish			Galvanized Steel Sheet <Munsell 3Y 7.8/ 1.1>									
External dimension H x W x D			mm			1,338 x 1,050 x 330 (+25)						
			inch			52-11/16 x 41-11/32 x 13 (+1)						
Protection devices			High pressure protection			HP switch						
			Inverter circuit (COMP./FAN)			Overcurrent detection, Overheat detection (Heat sink thermistor)						
			Compressor protection			Compressor thermo, Overcurrent detection						
			Fan motor protection			Overheating/Voltage protection						
Refrigerant			Type x original charge			R410A 10 lbs. 9 oz. (4.8kg)						
			Control			Linear Expansion Valve						
Net weight			lb (kg)			278 (126)						
Heat exchanger						Cross fin and tube						
HIC circuit (HIC: Heat Inter-Changer)						HIC circuit						
Defrosting method						Reversed refrigerant circuit						
Guaranteed operation range			(Cooling)			D.B 23 to 115°F [D.B.-5 to 46°C] *4*5*6						
			(Heating)			D.B. -13 to 70°F [D.B. -25 to 21°C]						
Remarks			Details on foundation work, duct work, insulation work, electrical wiring, power source switch, and other items shall be referred to the Installation Manual. Because of continuing improvement, above specifications may be subject to change without notice.									

*1 Rating conditions Cooling Indoor : D.B. 80°F/W.B. 67°F [D.B.26.7°C/W.B. 19.4°C]
 Outdoor : D.B. 95°F [D.B. 35.0°C]
 Heating Indoor : D.B. 70°F [D.B. 21.1°C]
 Outdoor : D.B. 47°F/W.B. 43°F [D.B. 8.3°C/W.B. 6.1°C]

*2 Conditions Heating Indoor : D.B. 70°F [D.B. 21.1°C]
 Outdoor : D.B. 17°F/W.B. 15°F [D.B. -8.3°C/W.B. -9.4°C]

*3 It can not be connected mixed CITY MULTI indoor unit and branch box indoor unit.

*4 D.B. 5 to 115°F [D.B. -15 to 46°C], when an optional Air Outlet Guide is installed.

However, this condition does not apply to the indoor units listed in *5.

*5 50 to 115°F (10 to 46°C)D.B.: When connecting PKFY-P06NBMU, PKFY-P08NHMU, PKFY-P04/06/08/12NLMU, PFFY-P06/08/12NEMU, and PFFY-P06/08/12NRMU type indoor unit.

*6 When the temperature is below D.B. 50°F [D.B. 10°C] with branch box system, noise could potentially occur.

Note: Refer to the indoor unit's service manual for the indoor units specifications.

Conversion formula:	kcal/h = kW × 860
	Btu/h = kW × 3412
	CFM = m³/min × 35.31

Service Ref.			MXZ-SM60NAM-U1					
Indoor type			Non-Ducted	Mix	Ducted			
M1-metric (AHR12/10/240-2017)	Cooling	Capacity Rated*1	Btu/h	60,000	60,000	60,000		
		Rated power consumption*1	W	4,510	4,920	5,405		
		Current input (208/230V)	A	21.9/19.8	23.9/21.6	26.3/23.8		
		EER	Btu/h/W	13.30	12.20	11.10		
		SEER	-	20.00	18.90	17.80		
		Capacity Rated 47°F*1	Btu/h	66,000	66,000	66,000		
	Heating	Capacity Max. 17°F*2	Btu/h	65,000	65,000	65,000		
		Capacity Max. 5°F	Btu/h	57,000	57,000	57,000		
		Rated power consumption 47°F*1	W	4,720	4,960	5,230		
		Current input (208/230V)	A	22.9/20.7	24.1/21.8	25.4/23.0		
		COP 47°F*1	W/W	4.10	3.90	3.70		
		HSPF IV / V	-	12.00/8.80	11.30/8.30	10.70/7.80		
		M1-metric (AHR12/10/240-2023)	Cooling	Capacity Rated*1	Btu/h	60,000	60,000	60,000
				Rated power consumption*1	W	4,515	5,065	5,770
Current input (208/230V)	A			21.9/19.8	24.6/22.3	28.0/25.4		
EER2	Btu/h/W			13.30	11.85	10.40		
SEER2	-			20.00	17.75	15.50		
Capacity Rated 47°F*1	Btu/h			66,000	66,000	66,000		
Heating	Capacity Max. 17°F*2		Btu/h	65,000	65,000	65,000		
	Capacity Max. 5°F		Btu/h	57,000	57,000	57,000		
	Rated power consumption 47°F*1		W	4,720	5,175	5,690		
	Current input (208/230V)		A	22.9/20.7	25.2/22.8	27.7/25.0		
	COP 47°F*1		W/W	4.10	3.74	3.40		
	HSPF2 IV / V		-	10.50/8.65	9.55/8.05	8.60/7.45		
	Power supply			1 Phase 208/230 V, 60 Hz				
	Breaker Size/Max. fuse size			40 A/50 A (When power is supplied separately), 50 A/55 A (When power is supplied from the outdoor unit)				
Min. circuit ampacity			36A (When power is supplied separately), 46A (When power is supplied from the outdoor unit)					
Indoor unit connectable		Total capacity	50 to 130% of outdoor unit capacity					
		Model/Quantity*3	CITY MULTI					
			Branch box					
Sound pressure level (measured in anechoic room)			dB <A>					
Refrigerant piping diameter		Liquid pipe	inch (mm)					
		Gas pipe	inch (mm)					
Fan		Type x Quantity	Propeller fan x 2					
		Airflow rate	m³/min					
			L/s					
			cfm					
		Control, Driving mechanism	DC control					
		Motor output	kW					
		External static press.	0					
Compressor		Type x Quantity	Scroll hermetic compressor x 1					
		Manufacture	Mitsubishi Electric Corporation					
		Starting method	Inverter					
		Motor output	kW					
		Case heater	kW					
		Lubricant	FVC68D 78oz. (2.3L)					
External finish			Galvanized Steel Sheet <Munsell 3Y 7.8/ 1.1>					
External dimension H x W x D			mm					
			inch					
Protection devices		High pressure protection	HP switch					
		Inverter circuit (COMP./FAN)	Overcurrent detection, Overheat detection(Heat sink thermistor)					
		Compressor protection	Compressor thermo, Overcurrent detection					
		Fan motor protection	Overheating/Voltage protection					
Refrigerant		Type x original charge	R410A 11 lbs. 4 oz. (5.1kg)					
		Control	Linear Expansion Valve					
Net weight		lb (kg)	302 (137)					
Heat exchanger			Cross fin and tube					
HIC circuit (HIC: Heat Inter-Changer)			HIC circuit					
Defrosting method			Reversed refrigerant circuit					
Guaranteed operation range		(Cooling)	D.B 23 to 115°F [D.B.-5 to 46°C] *4*5*6					
		(Heating)	D.B. -13 to 70°F [D.B. -25 to 21°C]					
Remarks			Details on foundation work, duct work, insulation work, electrical wiring, power source switch, and other items shall be referred to the Installation Manual. Because of continuing improvement, above specifications may be subject to change without notice.					

*1 Rating conditions Cooling Indoor : D.B. 80°F/W.B. 67 °F [D.B.26.7°C/W.B. 19.4°C]
Outdoor : D.B. 95°F [D.B. 35.0°C]
Heating Indoor : D.B. 70°F [D.B. 21.1°C]
Outdoor : D.B. 47°F/W.B. 43°F [D.B. 8.3°C/W.B. 6.1°C]
*2 Conditions Heating Indoor : D.B. 70°F [D.B. 21.1°C]
Outdoor : D.B. 17°F/W.B. 15°F [D.B. -8.3°C/W.B. -9.4°C]

Conversion formula:	kcal/h = kW × 860
	Btu/h = kW × 3412
	CFM = m³/min × 35.31

*3 It can not be connected mixed CITY MULTI indoor unit and branch box indoor unit.
*4 D.B. 5 to 115°F [D.B. -15 to 46°C], when an optional Air Outlet Guide is installed.
However, this condition does not apply to the indoor units listed in *5.
*5 50 to 115°F (10 to 46°C) D.B.: When connecting PKFY-P06NBMU, PKFY-P08NHMU,
PKFY-P04/06/08/12NLMU, PFFY-P06/08/12NEMU, and PFFY-P06/08/12NRMU type indoor unit.
*6 When the temperature is below D.B. 50°F [D.B. 10°C] with branch box system, noise could potentially occur.
Note: Refer to the indoor unit's service manual for the indoor units specifications.

4-1. SELECTION OF COOLING/HEATING UNITS

How to determine the capacity when less than or equal 100% indoor model size units are connected in total:

The purpose of this flow chart is to select the indoor and outdoor units. For other purposes, this flow chart is intended only for reference.

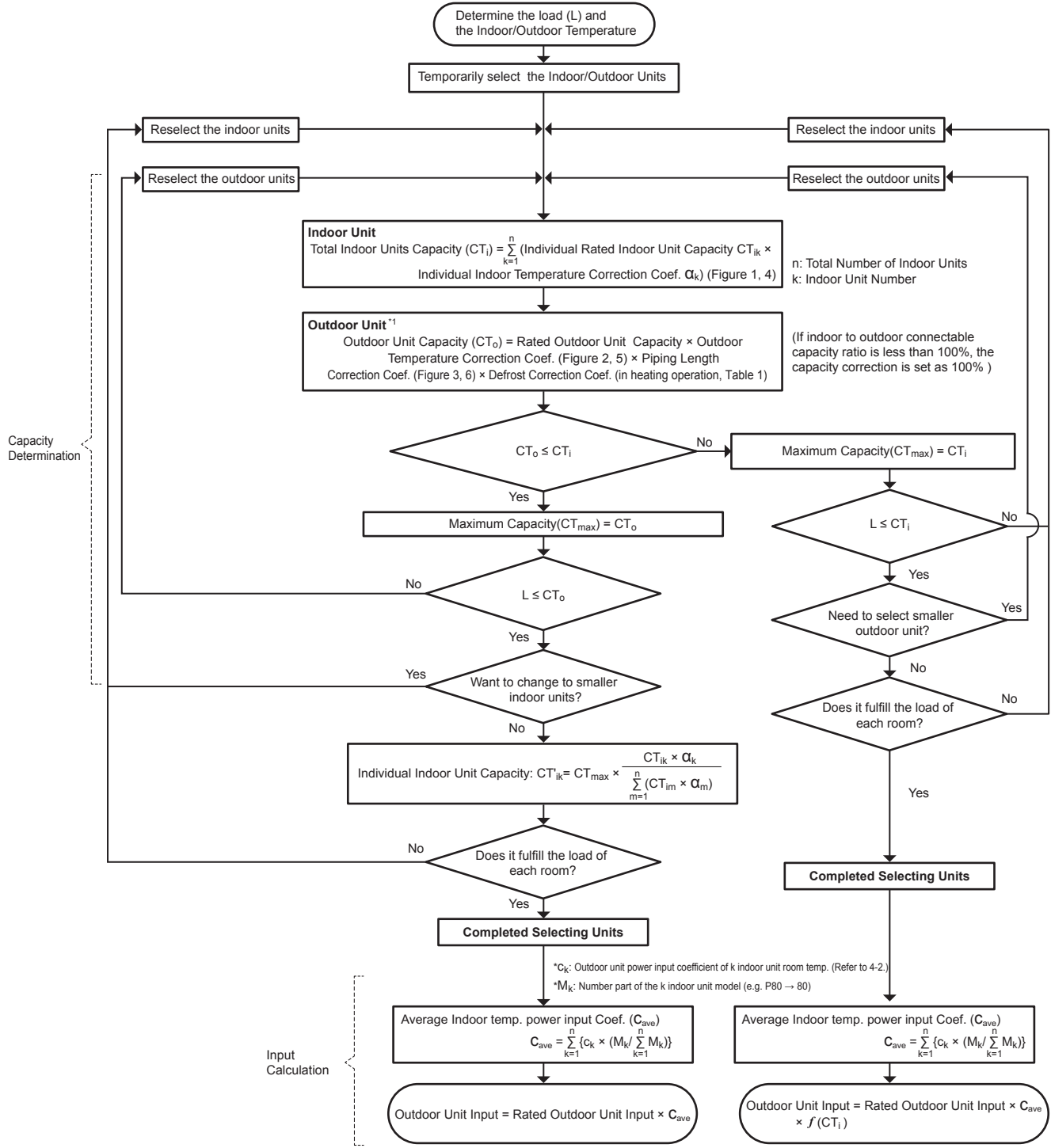

How to determine the capacity when greater than 100% indoor model size units are connected in total:

The purpose of this flow chart is to select the indoor and outdoor units. For other purposes, this flow chart is intended only for reference.

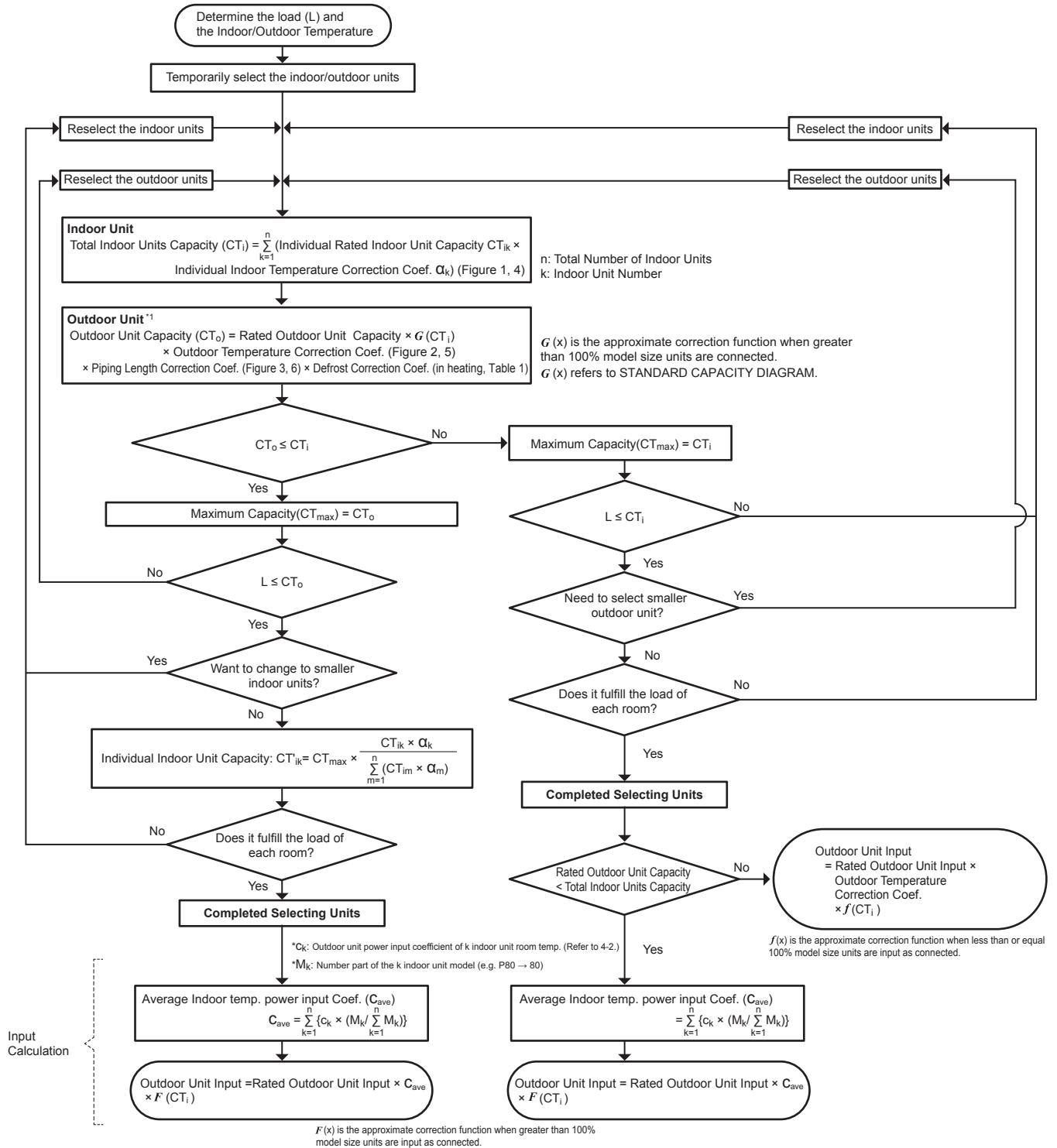

(7) Comparison with Essential Load

Against the essential load 30.3 kBtu/h, the maximum system capacity is 32.4 kBtu/h: Proper outdoor units have been selected.

(8) Calculation of Maximum Indoor Unit Capacity of Each Room

CTx = CTi, thus, calculate by the calculation below

Room1

Indoor Unit Rating × Indoor Design Temperature Correction
 = 15.0 × 1.02
 = 15.3 kBtu/h **OK: fulfills the load 13.6 kBtu/h**

Room2

Indoor Unit Rating × Indoor Design Temperature Correction
 = 18.0 × 0.95
 = 17.1 kBtu/h **OK: fulfills the load 16.7 kBtu/h**

Go on to the heating trial calculation since the selected units fulfill the cooling loads of Room 1, 2.

<Heating>

Design Condition	
Outdoor Design Wet Bulb Temperature	35.6°F (2.0°C)
Total Heating Load	34.4 kBtu/h
Room1	
Indoor Design Dry Bulb Temperature	69.8°F (21.0°C)
Heating Load	16.3 kBtu/h
Room2	
Indoor Design Dry Bulb Temperature	73.4°F (23.0°C)
Heating Load	18.1 kBtu/h
<Other>	
Indoor/Outdoor Equivalent Piping Length	328 ft

Capacity of indoor unit

(kBtu/h)

Model Number for indoor unit	Model 04	Model 05	Model 06	Model 08	Model 12	Model 15	Model 18	Model 24	Model 27	Model 30	Model 36	Model 48	Model 54
Model Capacity	4.5	5.6	6.7	9.0	13.5	17.0	20.0	27.0	30.0	34.0	40.0	54.0	60.0

Model name	Capacity class							
	06	09	12	15	18	24	30	36
SVZ	-	-	12.0	-	18.0	27.0	34.0	40.0
SLZ-KF	-	10.2	13.7	17.1	-	-	-	-
SEZ-KD	-	10.9	13.6	18.0	17.2	-	-	-
MFZ-KJ	-	10.9	13.0	18.0	21.0	-	-	-
MLZ-KP	-	10.9	13.0	-	21.0	-	-	-
MSZ-FH	6.0	10.9	13.6	18.0	20.3	-	-	-
MSZ-FS	6.0	10.9	13.6	18.0	20.3	-	-	-
MSZ-GL	6.0	10.9	14.4	18.0	21.6	27.6	-	-
MSZ-EF	-	10.9	13.0	18.0	21.0	-	-	-
PEAD	-	10.9	13.5	15.7	18.0	26.0	34.0	40.0
PLA	-	-	13.5	-	18.0	26.0	34.0	40.0

2. Heating Calculation

(1) Temporary Selection of Indoor Units

Room1

PEFY-P15 **17.0 kBtu/h (Rated)**

Room2

PEFY-P18 **20.0 kBtu/h (Rated)**

(2) Total Indoor Units Capacity

P15 + P18 = P33

(3) Selection of Outdoor Unit

The P36 outdoor unit is selected as total indoor units capacity is P33

MXZ-SM36NAM **42.0 kBtu/h**

(4) Total Indoor Units Capacity Correction Calculation

Room1

Indoor Design Dry Bulb Temperature Correction (69.8°F) 1.00 (Refer to Figure 4)

Room2

Indoor Design Dry Bulb Temperature Correction (73.4°F) 0.92 (Refer to Figure 4)

Total Indoor Units Capacity (CTi)

CTi = Σ (Indoor Unit Rating × Indoor Design Temperature Correction)
 = 17.0 × 1.00 + 20.0 × 0.92
 = 35.4 kBtu/h

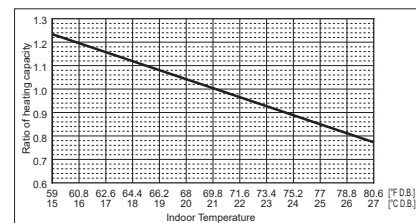

Figure 4 Indoor unit temperature correction
To be used to correct indoor unit only

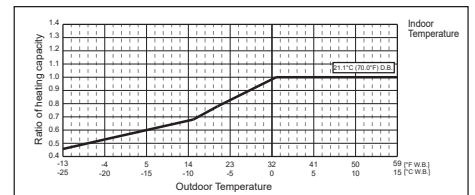

Figure 5 Outdoor unit temperature correction
To be used to correct outdoor unit only

(5) Outdoor Unit Correction Calculation

Outdoor Design Wet Bulb Temperature Correction (35.6°F) 1.0 (Refer to Figure 5)
 Piping Length Correction (328 ft) 0.94 (Refer to Figure 6)
 Defrost Correction 0.89 (Refer to Table 1)

Total Outdoor Unit Capacity (CTo)

$$CTo = \text{Outdoor Unit Rating} \times G(CTi)^{*1} \times \text{Outdoor Design Temperature Correction} \\ \times \text{Piping Length Correction} \times \text{Defrost Correction} \\ = 42.0 \times 1.0 \times 0.94 \times 0.89 \\ = 35.1 \text{ kBtu/h}$$

*1 G(CTi) is used only when greater than 100% indoor model size are connected in total, refer to STANDARD CAPACITY DIAGRAM.

Table 1 Table of correction factor at frost and defrost

Outdoor Intake temperature <W.B.:F (°C)>	43(6)	37(4)	36(2)	32(0)	28(-2)	25(-4)	21(-6)	18(-8)	14(-10)	5(-15)	-4(-20)	-13(-25)
Correction factor	1.0	0.98	0.89	0.88	0.89	0.9	0.95	0.95	0.95	0.95	0.95	0.95

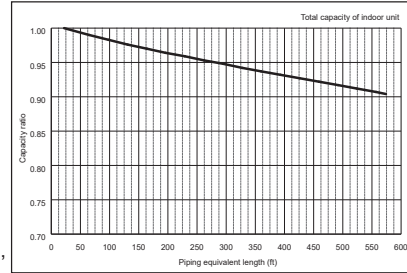

Figure 6 Correction of refrigerant piping length

(6) Determination of Maximum System Capacity

Comparison of Capacity between Total Indoor Units Capacity (CTi) and Total Outdoor Unit Capacity (CTo)

CTi = 35.4 > CTo = 35.1, thus, select CTo.

CTx = CTo = 35.1 kBtu/h

(7) Comparison with Essential Load

Against the essential load 34.4 kBtu/h, the maximum system capacity is 35.1 kBtu/h: Proper outdoor units have been selected.

(8) Calculation of Maximum Indoor Unit Capacity of Each Room

CTx = CTo, thus, calculate by the calculation below

Room1

$$\text{Maximum Capacity} \times \text{Room1 Capacity after the Temperature Correction} / (\text{Room1,2 Total Capacity after the Temperature Correction}) \\ = 35.1 \times (17.0 \times 1.00) / (17.0 \times 1.00 + 20.0 \times 0.92) \\ = 16.9 \text{ kBtu/h} \quad \text{OK: fulfills the load 16.3 kBtu/h}$$

Room2

$$\text{Maximum Capacity} \times \text{Room1 Capacity after the Temperature Correction} / (\text{Room1,2 Total Capacity after the Temperature Correction}) \\ = 35.1 \times (20.0 \times 0.92) / (17.0 \times 1.00 + 20.0 \times 0.92) \\ = 18.2 \text{ kBtu/h} \quad \text{OK: fulfills the load 18.1 kBtu/h}$$

Completed selecting units since the selected units fulfill the heating loads of Room 1, 2.

3. Power input of outdoor unit

Outdoor unit: MXZ-SM36NAM

Indoor unit 1: PEFY-P15

Indoor unit 2: PEFY-P18

<Cooling>

(1) Rated power input of outdoor unit 2.31 kW

(2) Calculation of the average indoor temperature power input coefficient

Coefficient of the outdoor unit for indoor unit 1 (Outdoor temp. 98.6°F [37.0°C] D.B., Indoor temp. 68.0°F [20.0°C] W.B.)
 1.04 (Refer to "4-2. CORRECTION BY TEMPERATURE".)

Coefficient of the outdoor unit for indoor unit 2 (Outdoor temp. 98.6°F [37.0°C] D.B., Indoor temp. 64.4°F [18.0°C] W.B.)
 0.85 (Refer to "4-2. CORRECTION BY TEMPERATURE".)

$$\text{Average indoor temp. power input coefficient } (C_{ave}) = \sum_{k=1}^n \{c_k \times (M_k / \sum_{k=1}^n M_k)\}$$

n: Total number of the indoor units
 k: Number of the indoor unit
 c_k: Outdoor unit power input coefficient of k indoor unit room temp.
 M_k: Number part of the k indoor unit model (e.g. P80 → 80)

$$\text{Correction Coefficient of Indoor temperature} = 1.04 \times 15 / (15 + 18) + 0.85 \times 18 / (15 + 18) \\ = 0.94$$

(3) Coefficient of the partial load f (CTi)

Total Indoor units capacity
 15 + 18 = 33, thus, f (CTi) = 0.9 (Refer to the tables in "4-4.STANDARD CAPACITY DIAGRAM".)

(4) Outdoor power input (Plo)

Maximum System Capacity (CTx) = Total Outdoor unit Capacity (CTo), so use the following formula
 Plo = Outdoor unit Cooling Rated Power Input × Correction Coefficient of Indoor temperature × f (CTi)
 = 2.31 × 0.94 × 0.9
 = 1.95 kW

<Heating>

(1) Rated power input of outdoor unit **3.02 kW**

(2) Calculation of the average indoor temperature power input coefficient

Coefficient of the outdoor unit for indoor unit 1 (Outdoor temp. 26.6°F [-3°C] W.B., Indoor temp. 70°F [21.1°C] D.B.)

1.16 (Refer to "4-2. CORRECTION BY TEMPERATURE".)

Coefficient of the outdoor unit for indoor unit 2 (Outdoor temp. 26.6°F [-3°C] W.B., Indoor temp. 78.8°F [26°C] D.B.)

1.09 (Refer to "4-2. CORRECTION BY TEMPERATURE".)

Average indoor temp. power input coefficient (C_{ave}) = $\sum_{k=1}^n \{c_k \times (M_k / \sum_{k=1}^n M_k)\}$

n: Total number of the indoor units

k: Number of the indoor unit

c_k : Outdoor unit power input coefficient of k indoor unit room temp.

M_k : Number part of the k indoor unit model (e.g. P80 → 80)

Correction Coefficient of Indoor temperature = $1.16 \times 15 / (15 + 18) + 1.09 \times 18 / (15 + 18)$
= 1.12

(3) Coefficient of the partial load $f(\text{CTi})$

Total indoor units capacity

$15 + 18 = 33$, thus, $f(\text{CTi}) = 0.9$ (Refer to the tables in "4-4. STANDARD CAPACITY DIAGRAM".)

(4) Outdoor power input (Plo)

Maximum System Capacity (CTx) = Total Indoor unit Capacity (CTi), so use the following formula

Plo = Outdoor unit Heating Rated Power Input × Correction Coefficient of Indoor temperature × $f(\text{CTi})$

= $3.02 \times 1.12 \times 0.9$

= 3.04 kW

4-2. CORRECTION BY TEMPERATURE

CITY MULTI could have varied capacity at different designing temperature. Using the nominal cooling/heating capacity value and the ratio below, the capacity can be observed at various temperature.

<Cooling>

Figure 7 Indoor unit temperature correction

To be used to correct indoor unit capacity only

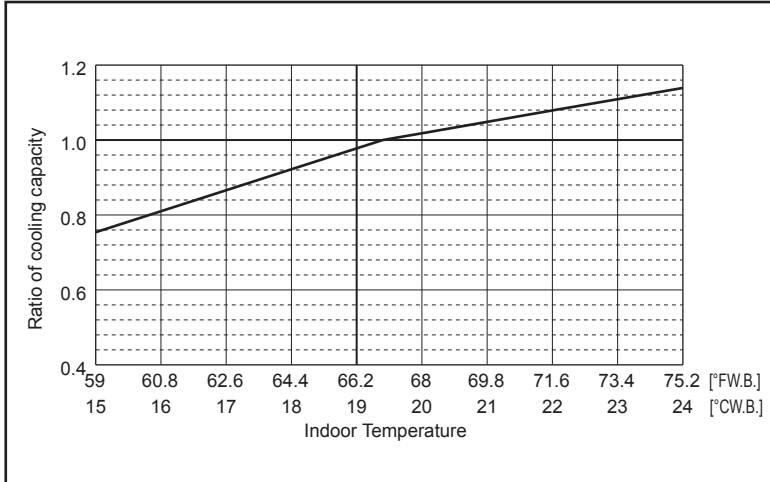
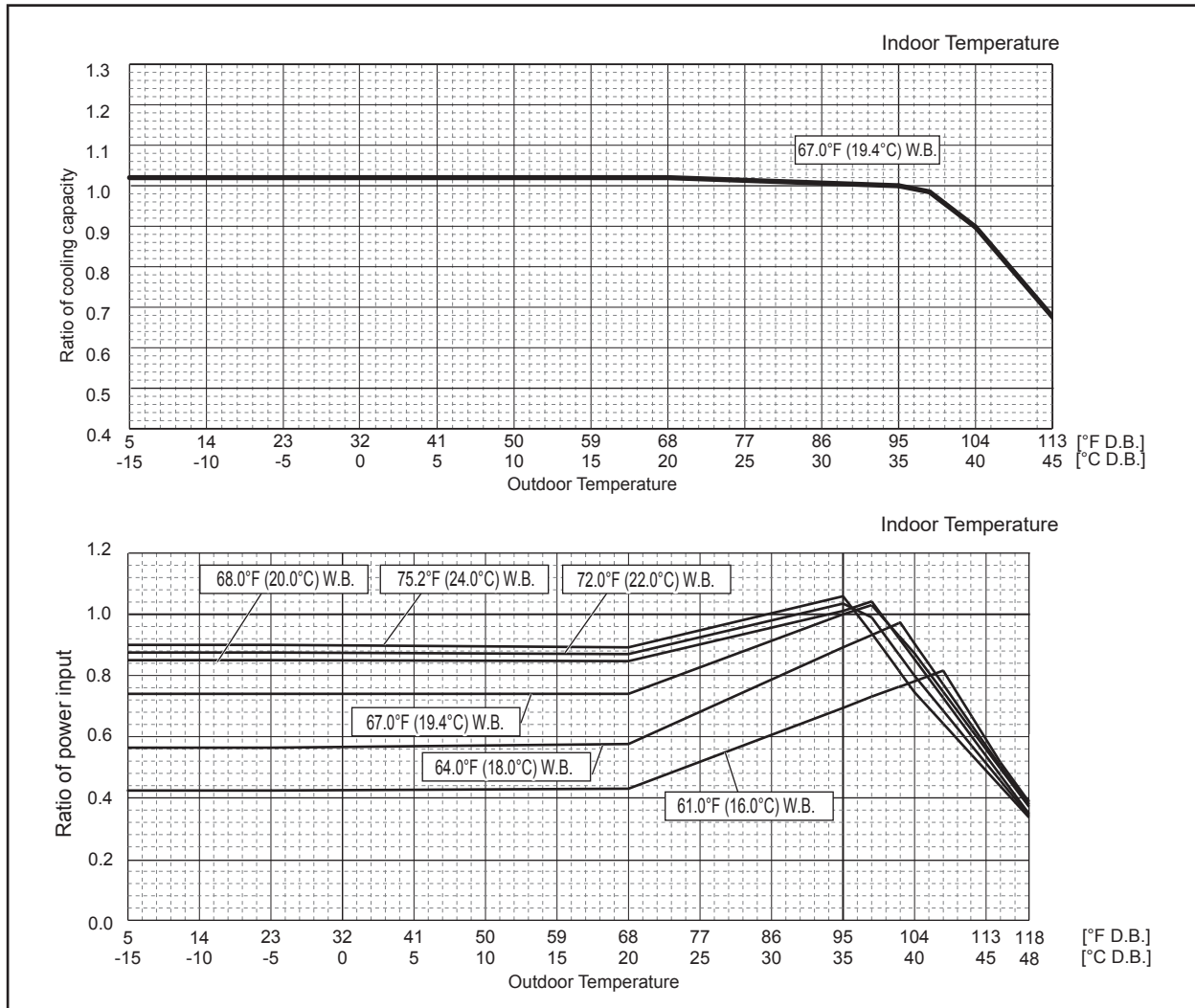

Figure 8 Outdoor unit temperature correction

To be used to correct outdoor unit capacity only



<Heating>

MXZ-SM36NAM-U1

MXZ-SM48NAM-U1

MXZ-SM60NAM-U1

Figure 9 Indoor unit temperature correction

To be used to correct indoor unit capacity only

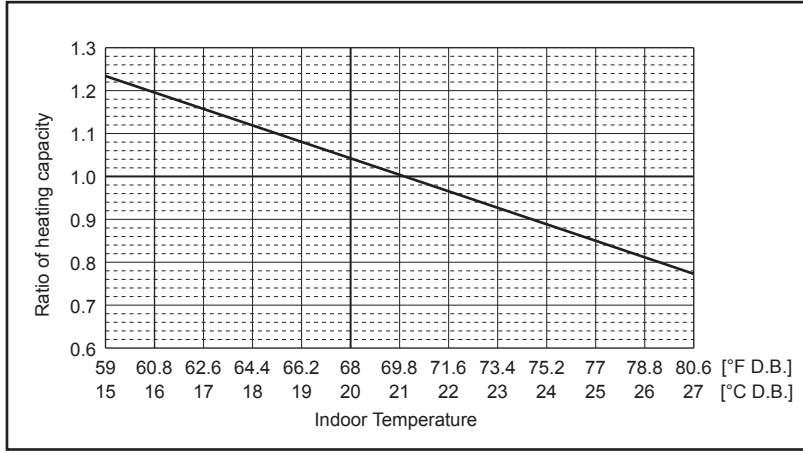
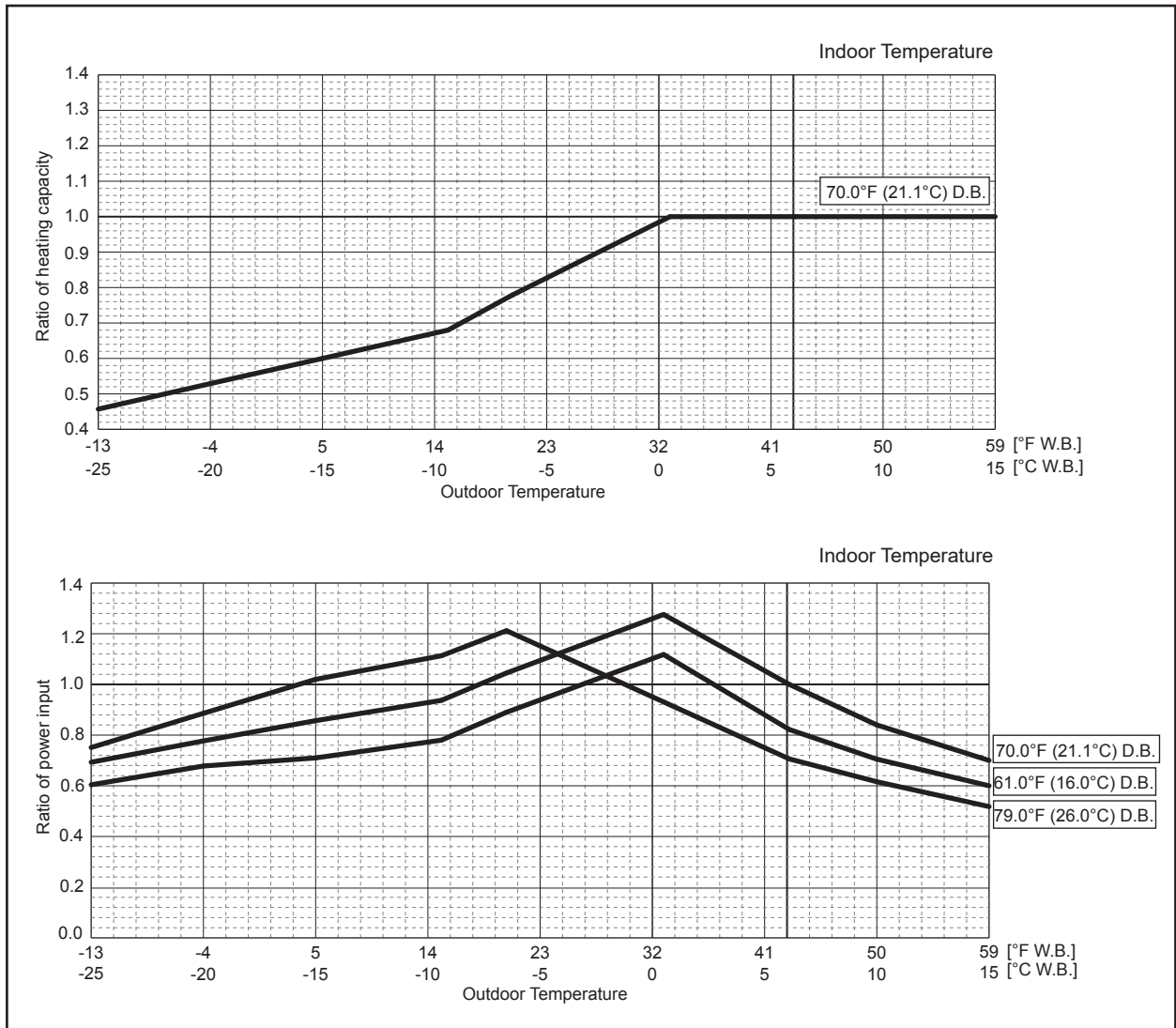

Figure 10 Outdoor unit temperature correction

To be used to correct outdoor unit capacity only



<Heating>

MXZ-SM36NAMHZ-U1

MXZ-SM42NAMHZ-U1

MXZ-SM48NAMHZ-U1

Figure 11 Indoor unit temperature correction

To be used to correct indoor unit capacity only

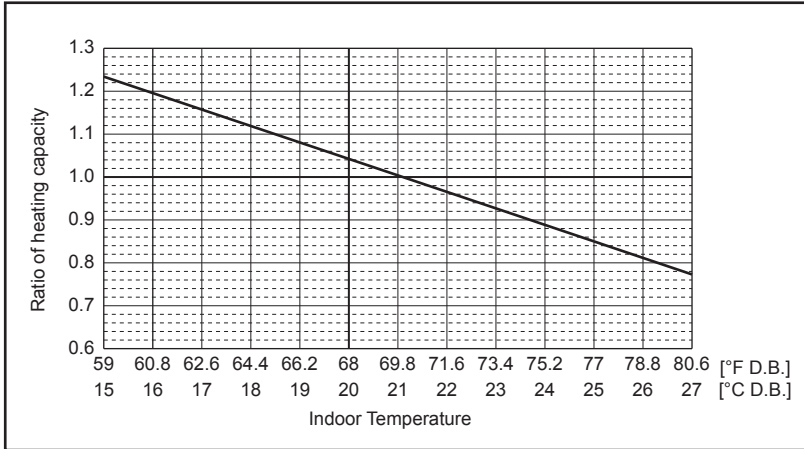
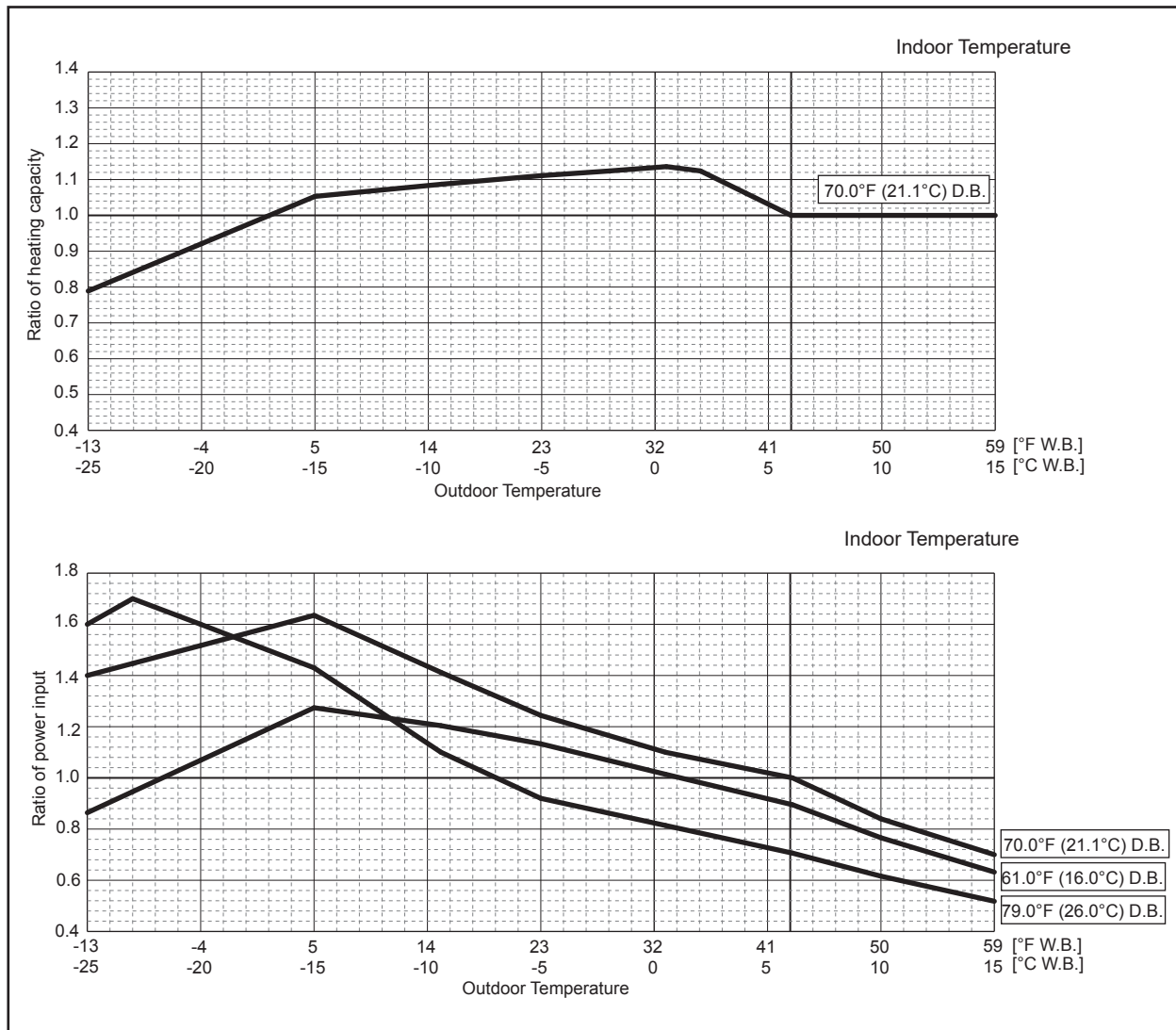

Figure 12 Outdoor unit temperature correction

To be used to correct outdoor unit capacity only



4-3. STANDARD OPERATION DATA (REFERENCE DATA)

Operation				MXZ-SM36NAM-U1		MXZ-SM48NAM-U1		MXZ-SM60NAM-U1	
Operating conditions	Ambient temperature	Indoor	DB/WB	80°F/67°F [26.7°C / 19.4°C]	70°F/60°F [21.1°C/15.6°C]	80°F/67°F [26.7°C/19.4°C]	70°F/60°F [21.1°C/15.6°C]	80°F/67°F [26.7°C/19.4°C]	70°F/60°F [21.1°C/15.6°C]
		Outdoor		95°F/75°F [35.0°C/23.9°C]	47°F / 43°F [8.3°C/6.1°C]	95°F/ 75°F [35.0°C / 23.9°C]	47°F/43°F [8.3°C/6.1°C]	95°F/75°F [35.0°C/23.9°C]	47°F/43°F [8.3°C/6.1°C]
	Indoor unit	No. of connected units	Unit	3		4		4	
		No. of units in operation		3		4		4	
		Model		—		12 × 3		12 × 4	
	Piping	Main pipe	Ft (m)	9.84 (3)		9.84 (3)		9.84 (3)	
		Branch pipe		14.76 (4.5)		14.76 (4.5)		14.76 (4.5)	
		Total pipe length		54.13 (16.5)		68.90 (21)		68.90 (21)	
	Fan speed	—		Hi		Hi		Hi	
	Amount of refrigerant	LBS. OZ. (kg)		17 LBS. (7.7)		17 LBS. 3 OZ. (7.8)		19 LBS. 6 OZ. (8.8)	
Outdoor unit	Electric current	A	10.2	13.3	15.6	17.1	19.3	20.4	
	Voltage	V	230		230		230		
	Compressor frequency	Hz	47	66	64	81	53	64	
LEV opening	Indoor unit	Pulse	268	438	247	313	386	498	
Pressure	High pressure/Low pressure	PSIG [MPaG]	370/116 [2.55/0.80]	406/104 [2.80/0.72]	419/112 [2.89/0.77]	409/97 [2.82/0.67]	397/144 [2.74/0.99]	425/97 [2.93/0.67]	
Temp. of each section	Outdoor unit	Discharge	°F [°C]	139.1 [59.5]	145.8 [63.2]	154.2 [67.9]	149.2 [65.1]	141.8 [61.0]	154.4 [68.0]
		Heat exchanger outlet		101.3 [38.5]	34.3 [1.3]	99.7 [37.6]	32.2 [0.1]	99.9 [37.7]	33.1 [0.6]
		Accumulator inlet		49.5 [9.7]	33.4 [0.8]	47.1 [8.4]	31.3 [-0.4]	52.7 [11.5]	32.2 [0.1]
		Compressor inlet		45.3 [7.4]	33.6 [0.9]	42.4 [5.8]	32.7 [0.4]	53.4 [11.9]	30.9 [-0.6]
	Indoor unit	Lev inlet	83.7 [28.7]	100.2 [37.9]	71.1 [21.7]	98.8 [37.1]	89.6 [32.0]	104.0 [40.0]	
		Heat exchanger inlet	49.6 [9.8]	132.3 [55.7]	47.5 [8.6]	134.6 [57.0]	56.1 [13.4]	141.8 [61.0]	

Operation				MXZ-SM36NAMHZ-U1		MXZ-SM42NAMHZ-U1		MXZ-SM48NAMHZ-U1	
Operating conditions	Ambient temperature	Indoor	DB/WB	80°F/67°F [26.7°C/19.4°C]	70°F/60°F [21.1°C/15.6°C]	80°F/67°F [26.7°C/19.4°C]	70°F/60°F [21.1°C/15.6°C]	80°F/67°F [26.7°C/19.4°C]	70°F/60°F [21.1°C/15.6°C]
		Outdoor		95°F/75°F [35.0°C/23.9°C]	47°F / 43°F [8.3°C/6.1°C]	95°F/ 75°F [35.0°C/23.9°C]	47°F/43°F [8.3°C/6.1°C]	95°F/ 75°F [35.0°C/23.9°C]	47°F/43°F [8.3°C/6.1°C]
	Indoor unit	No. of connected units	Unit	3		3		4	
		No. of units in operation		3		3		4	
		Model		—		12 × 3		12 × 2 + 18 × 1	
	Piping	Main pipe	Ft (m)	9.84 (3)		9.84 (3)		9.84 (3)	
		Branch pipe		14.76 (4.5)		14.76 (4.5)		14.76 (4.5)	
		Total pipe length		54.13 (16.5)		68.90 (21)		68.90 (21)	
	Fan speed	—		Hi		Hi		Hi	
	Amount of refrigerant	LBS. OZ. (kg)		17 LBS. (7.7)		17 LBS. (7.7)		17 LBS. 3 OZ. (7.8)	
Outdoor unit	Electric current	A	10.2	13.3	13.4	14.8	15.6	17.1	
	Voltage	V	230		230		230		
	Compressor frequency	Hz	47	66	58	70	64	81	
LEV opening	Indoor unit	Pulse	268	438	234/358	292/437	247	313	
Pressure	High pressure/Low pressure	PSIG [MPaG]	370/116 [2.55/0.80]	406/104 [2.80/0.72]	403/155 [2.78/1.07]	332/100 [2.29/0.69]	419/112 [2.89/0.77]	409/97 [2.82/0.67]	
Temp. of each section	Outdoor unit	Discharge	°F [°C]	139.1 [59.5]	145.8 [63.2]	142.9 [61.6]	131.7 [55.4]	154.2 [67.9]	149.2 [65.1]
		Heat exchanger outlet		101.3 [38.5]	34.3 [1.3]	100.9 [38.3]	32.9 [0.5]	99.7 [37.6]	32.2 [0.1]
		Accumulator inlet		49.5 [9.7]	33.4 [0.8]	55.4 [13.0]	31.8 [-0.1]	47.1 [8.4]	31.3 [-0.4]
		Compressor inlet		45.3 [7.4]	33.6 [0.9]	54.5 [12.5]	31.1 [-0.5]	42.4 [5.8]	32.7 [0.4]
	Indoor unit	Lev inlet	83.7 [28.7]	100.2 [37.9]	73.8 [23.2]	79.0 [26.1]	71.1 [21.7]	98.8 [37.1]	
		Heat exchanger inlet	49.6 [9.8]	132.3 [55.7]	56.5 [13.6]	123.8 [51.0]	47.5 [8.6]	134.6 [57.0]	

4-4. STANDARD CAPACITY DIAGRAM

Before calculating the sum of total capacity of indoor units, please convert the value into the kW model capacity following the formula on "4-1-1. Method for obtaining system cooling and heating capacity".

4-4-1. MXZ-SM36NAM-U1

MXZ-SM36NAMHZ-U1

<Cooling>

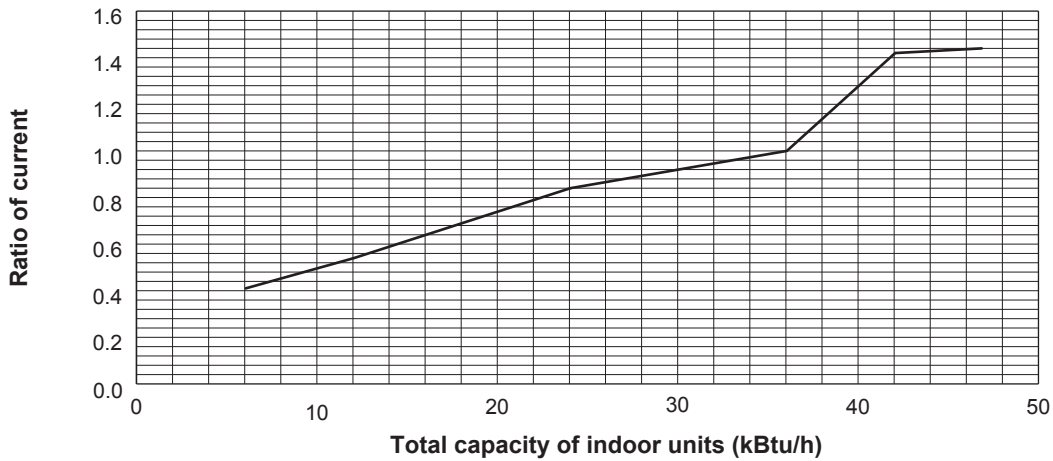
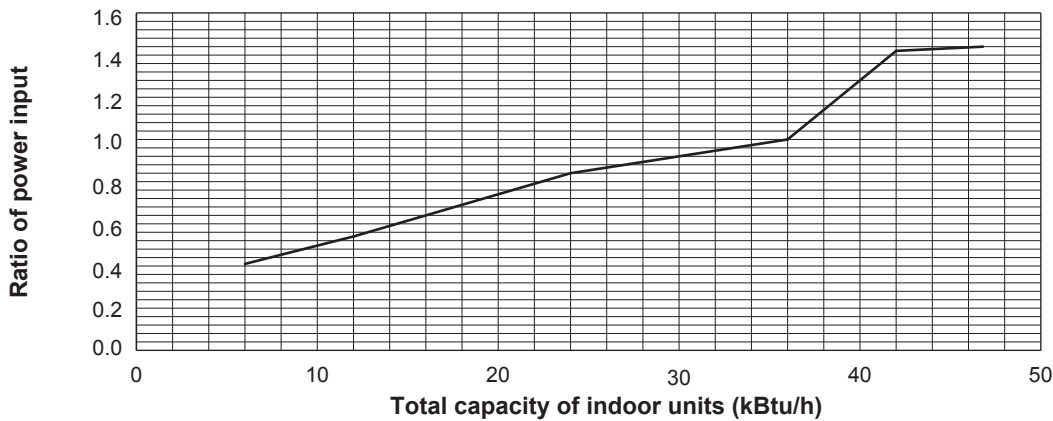
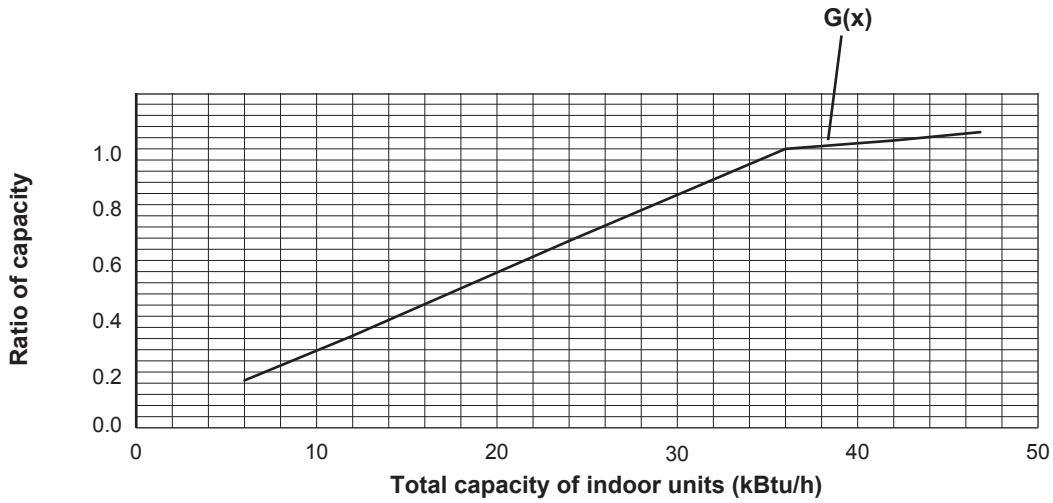

— 208, 230 V

4-4-2. MXZ-SM36NAM-U1

MXZ-SM36NAMHZ-U1

<Heating>

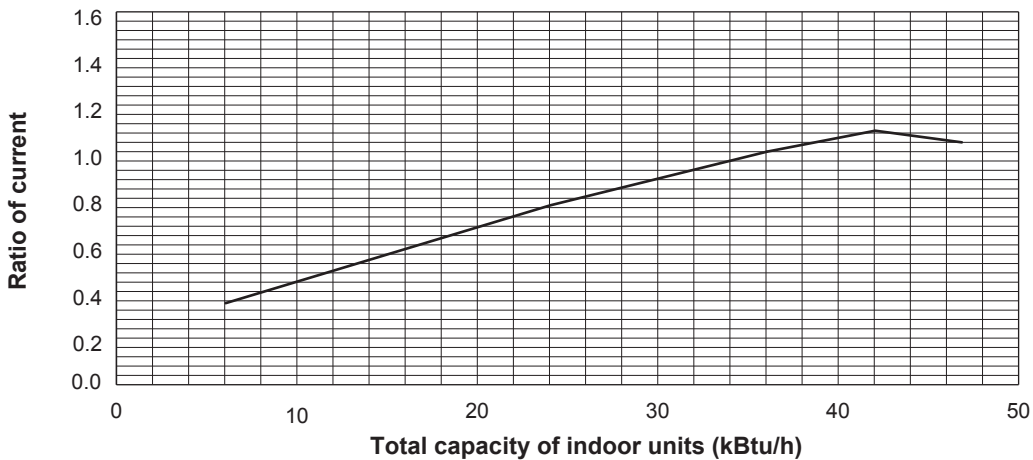
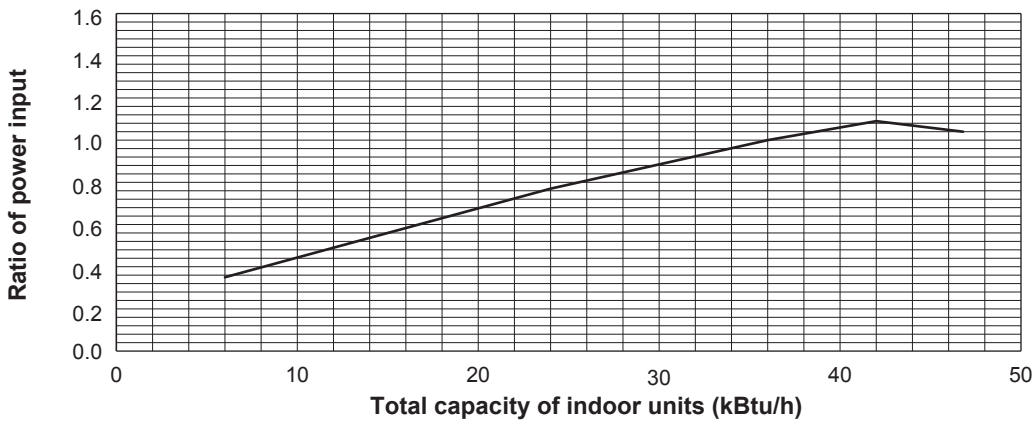
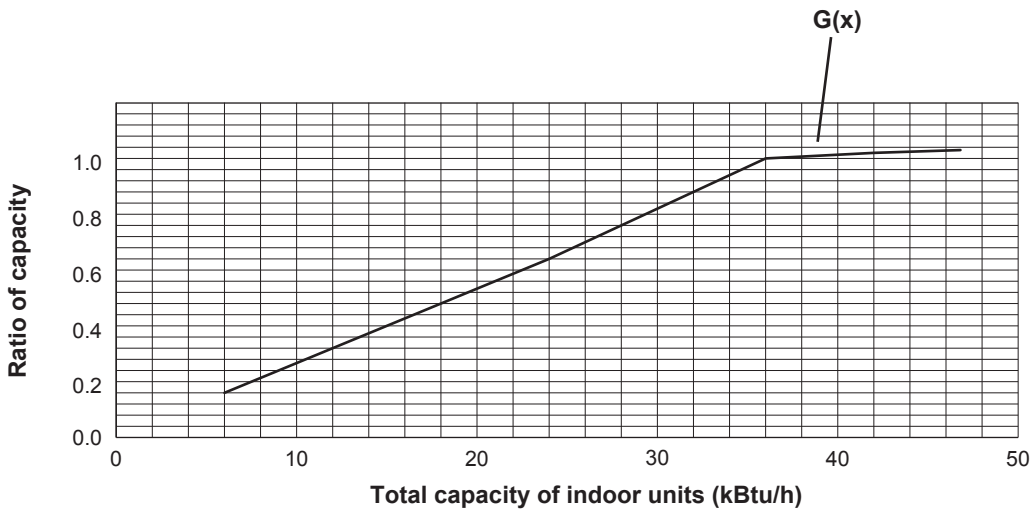

4-4-3. MXZ-SM42NAMHZ-U1

<Cooling>

		Non-Ducted	Mix	Ducted
Nominal cooling capacity	Btu/h	42,000	42,000	42,000
Input	W	3,130	3,470	3,890
Current (208V)	A	15.5	17.1	19.0
Current (230V)	A	14.0	15.4	17.2

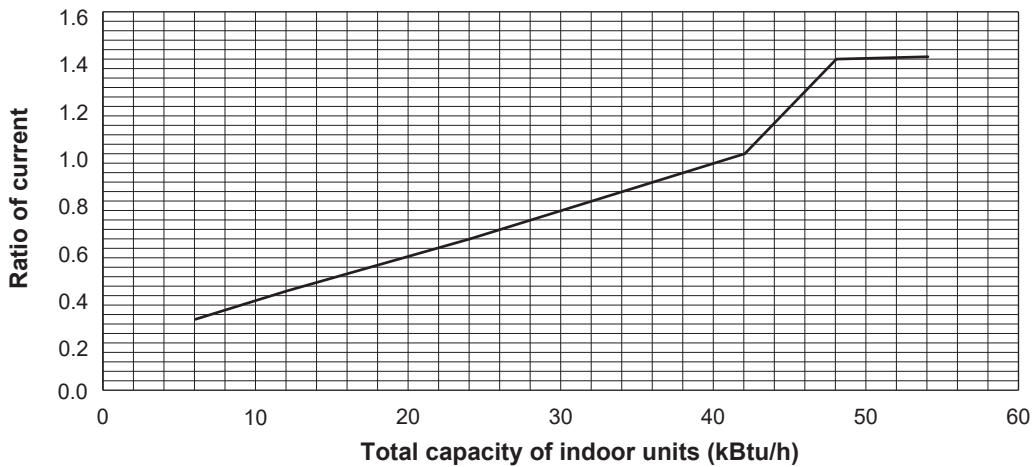

— 208, 230 V

4-4-4. MXZ-SM42NAMHZ-U1

<Heating>

		Non-Ducted	Mix	Ducted
Nominal heating capacity	Btu/h	48,000	48,000	48,000
Input	W	3,430	3,750	4,140
Current (208V)	A	16.8	18.3	20.2
Current (230V)	A	15.2	16.6	18.3

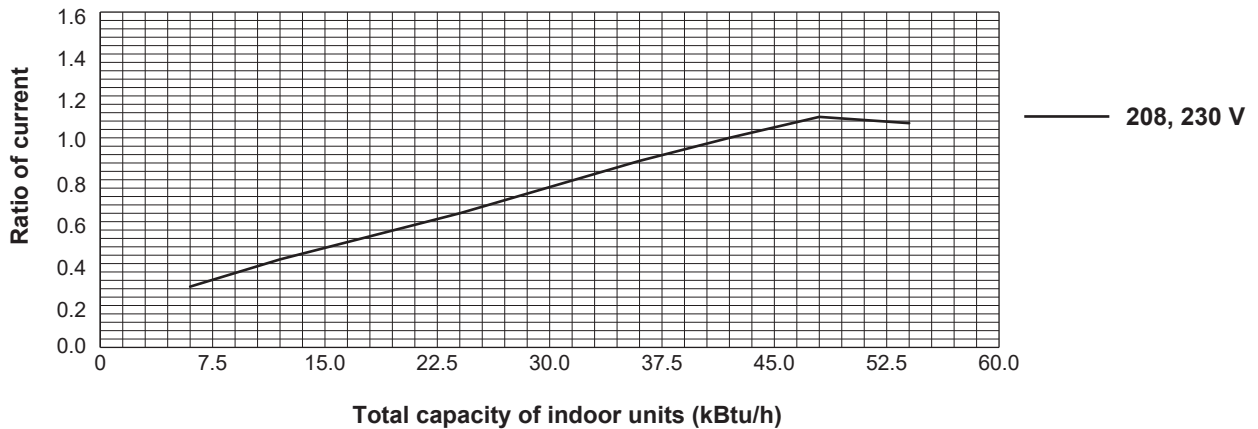
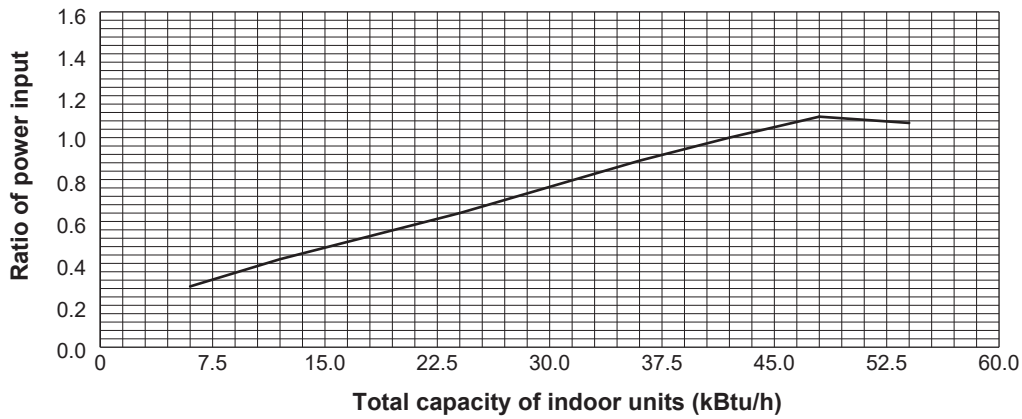
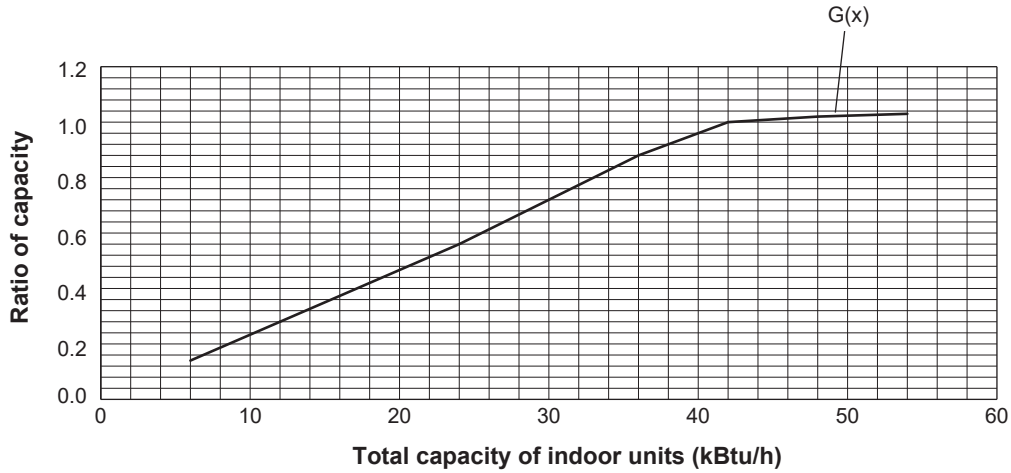

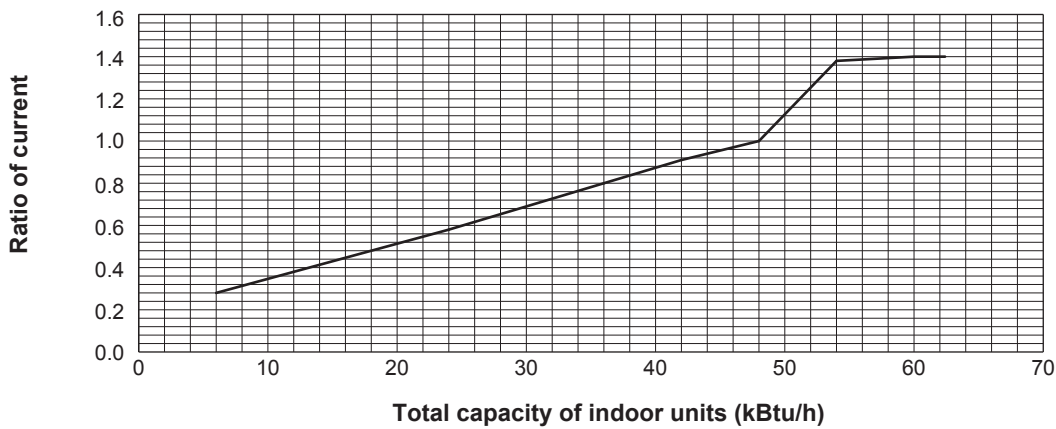
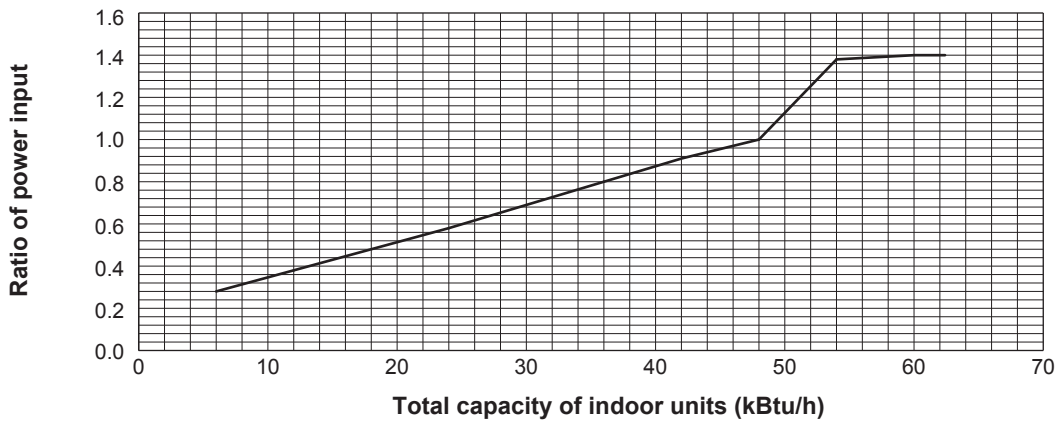
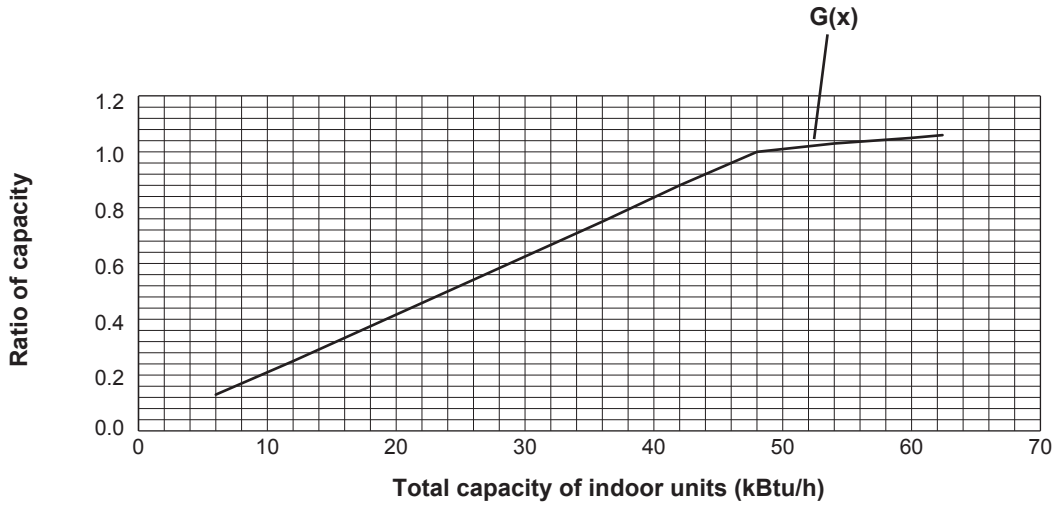

— 208, 230 V

4-4-6. MXZ-SM48NAM-U1

MXZ-SM48NAMHZ-U1

<Heating>

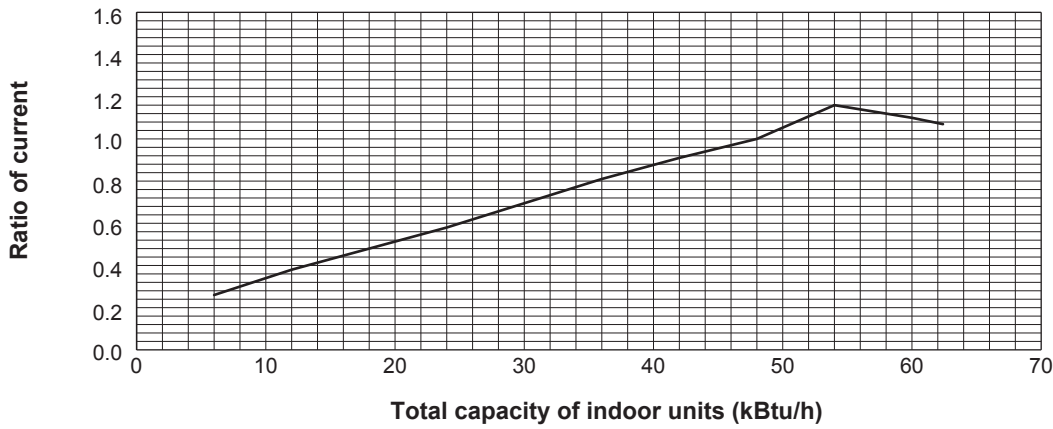
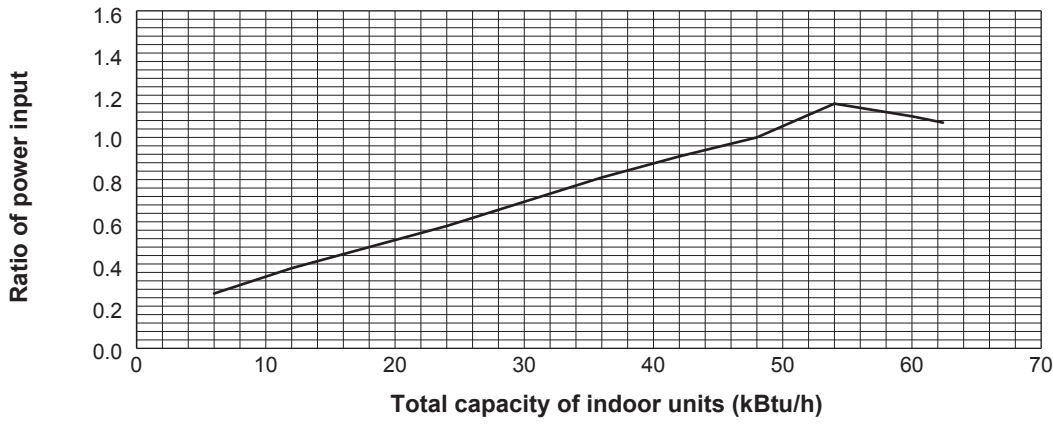
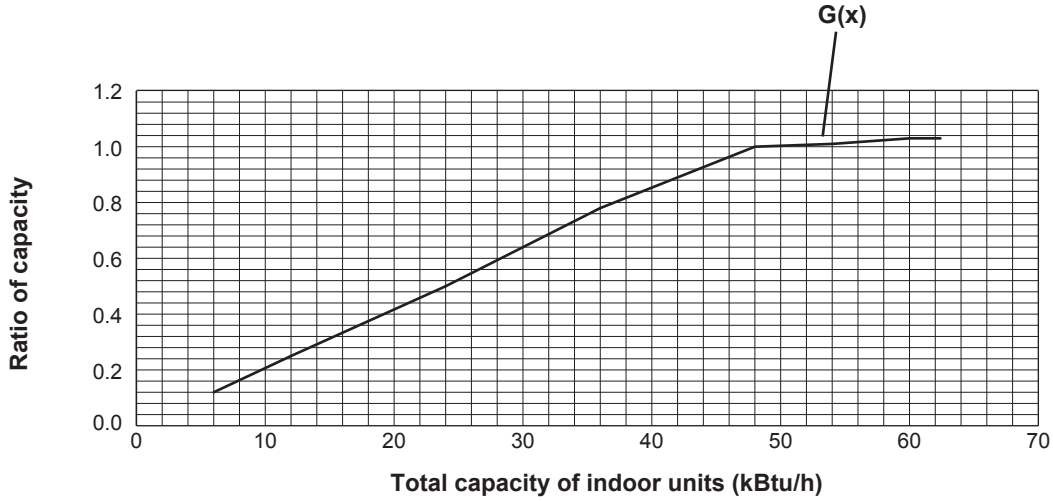

4-4-7. MXZ-SM60NAM-U1

<Cooling>

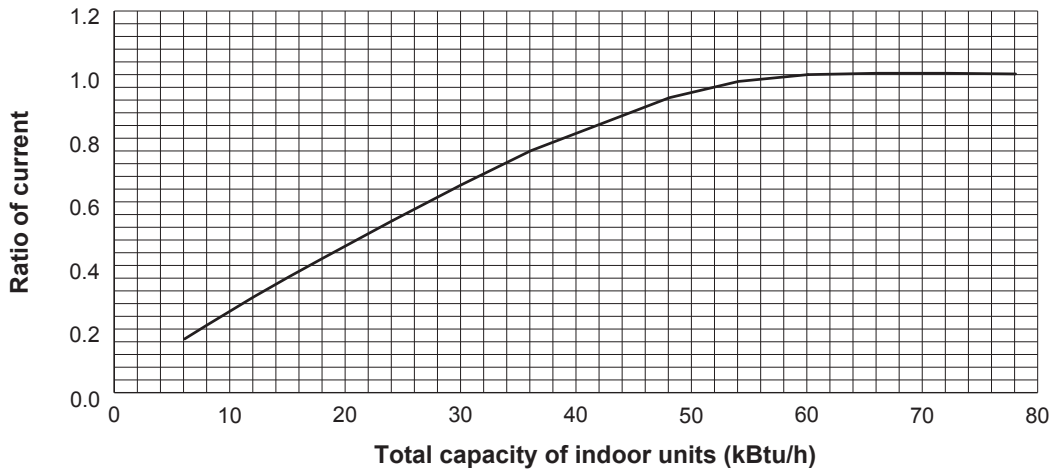
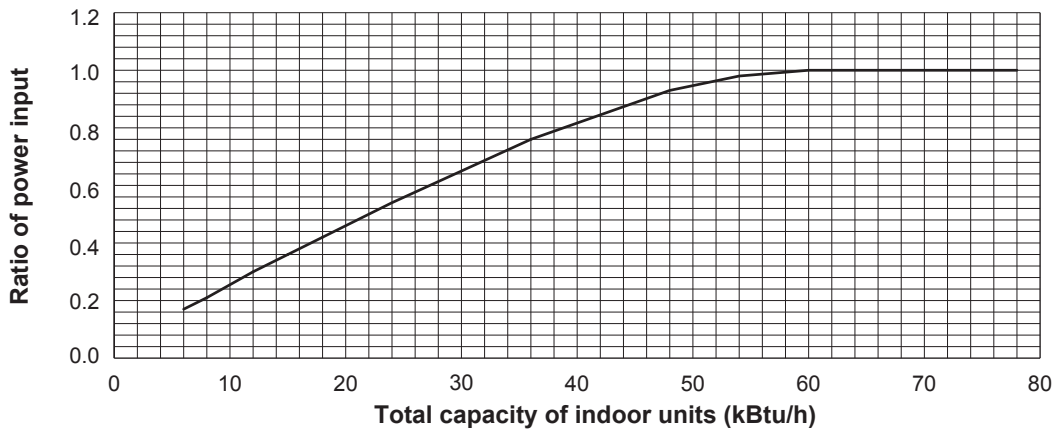
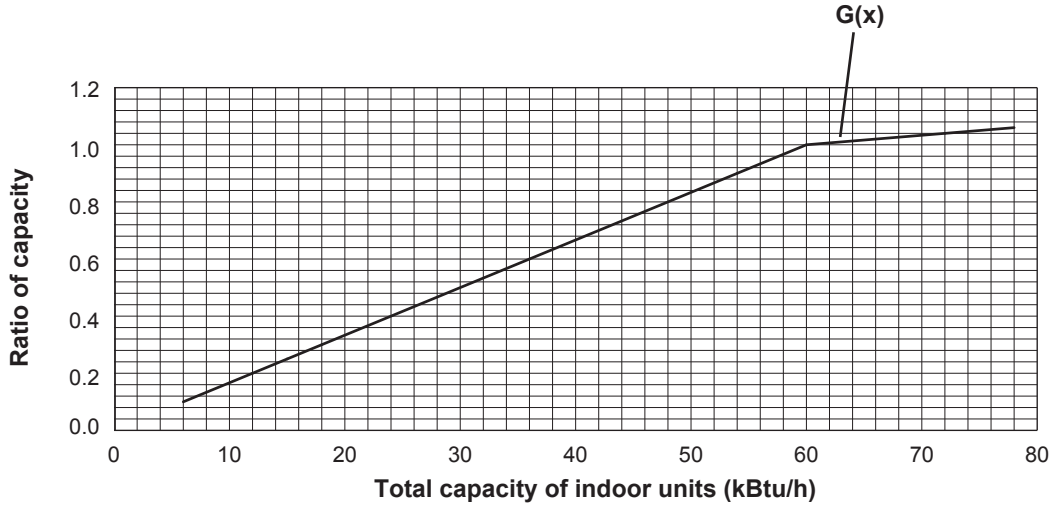

208, 230 V

4-4-8. MXZ-SM60NAM-U1

<Heating>

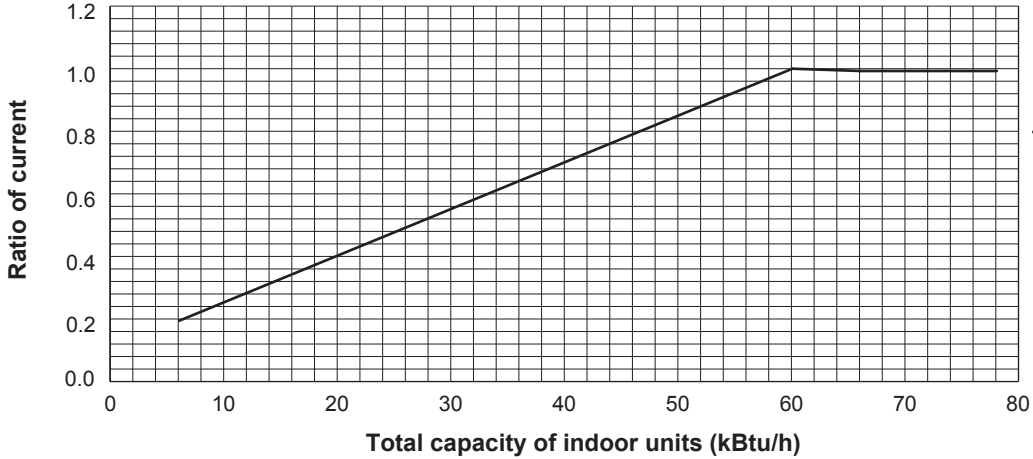
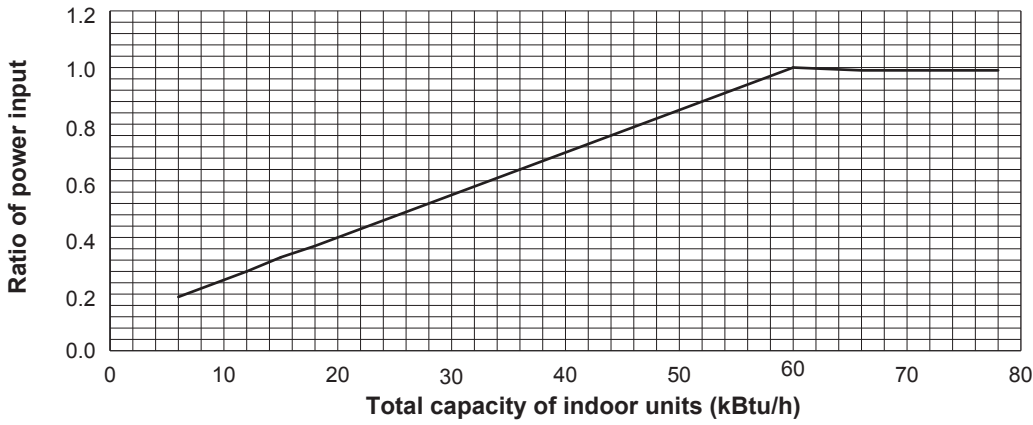
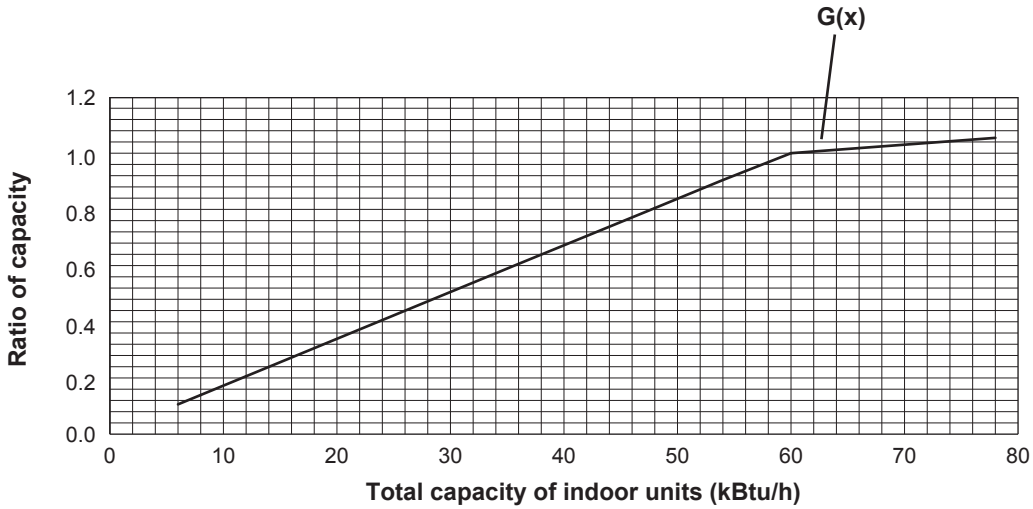

4-5. CORRECTING CAPACITY FOR CHANGES IN THE LENGTH OF REFRIGERANT PIPING

- (1) During cooling, obtain the ratio (and the equivalent piping length) of the outdoor units rated capacity and the total in-use indoor capacity, and find the capacity ratio corresponding to the standard piping length from Figure 13 to 17. Then multiply by the cooling capacity from Figure 7 and 8 in "4-2. CORRECTION BY TEMPERATURE" to obtain the actual capacity.
- (2) During heating, find the equivalent piping length, and find the capacity ratio corresponding to standard piping length from Figure 13. Then multiply by the heating capacity from Figure 9 and 10 in "4-2. CORRECTION BY TEMPERATURE" to obtain the actual capacity.

(1) Capacity Correction Curve

Figure 13 MXZ-SM36NAM-U1 MXZ-SM36NAMHZ-U1 <Cooling>

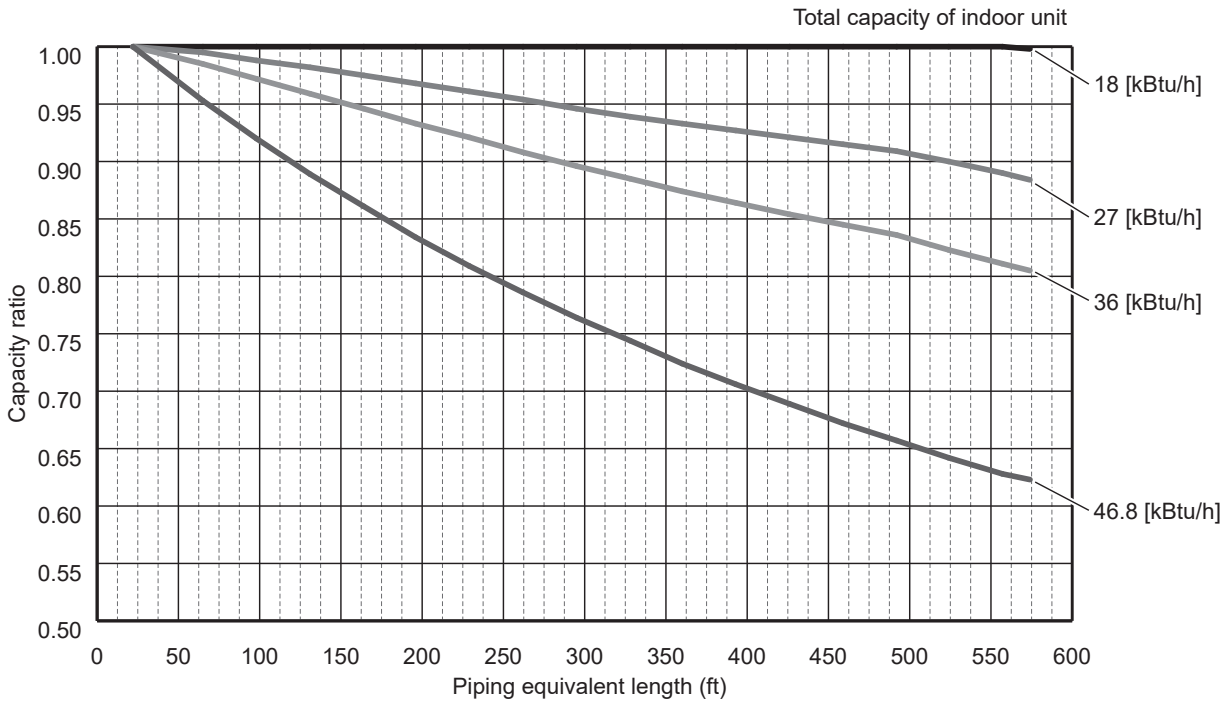

Figure 14 MXZ-SM42NAMHZ-U1 <Cooling>

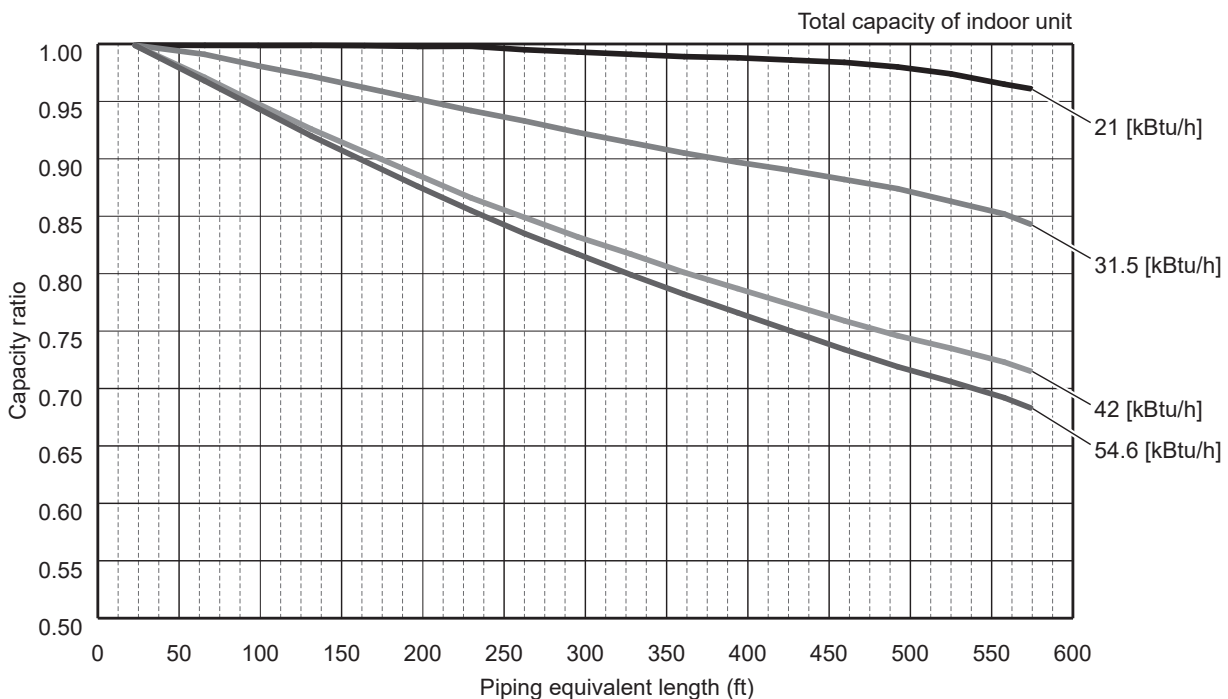

Figure 15 MXZ-SM48NAM-U1

MXZ-SM48NAMHZ-U1

<Cooling>

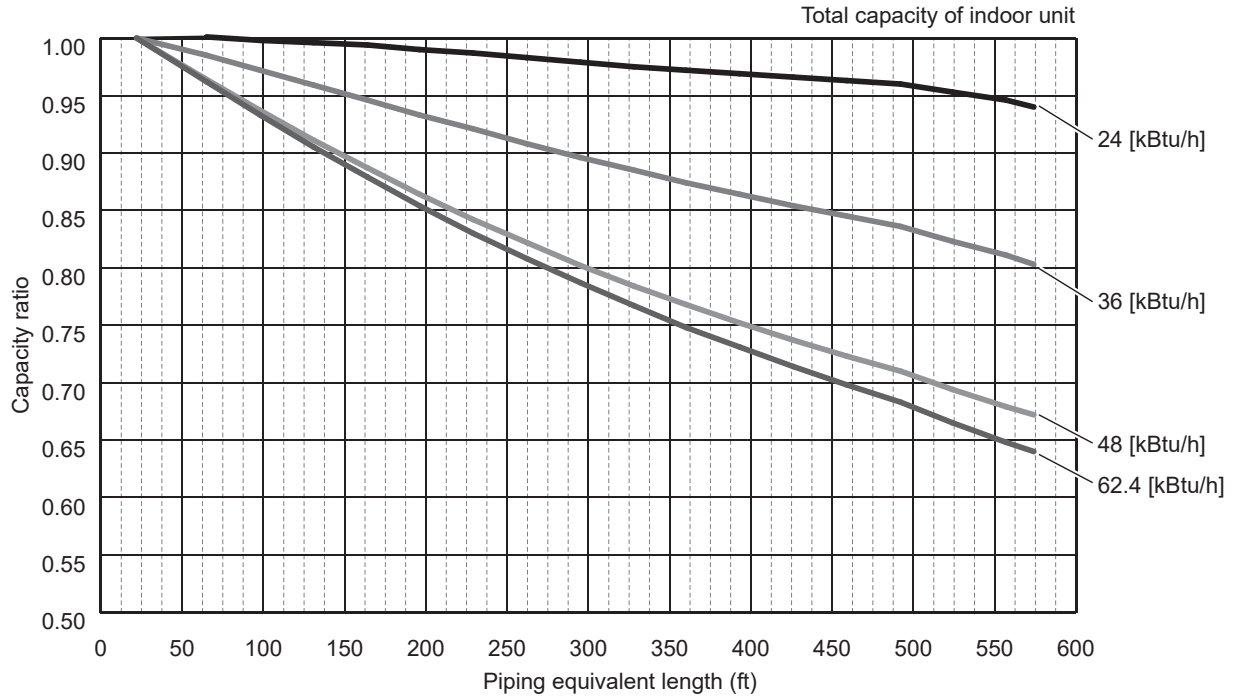

Figure 16 MXZ-SM60NAM-U1

<Cooling>

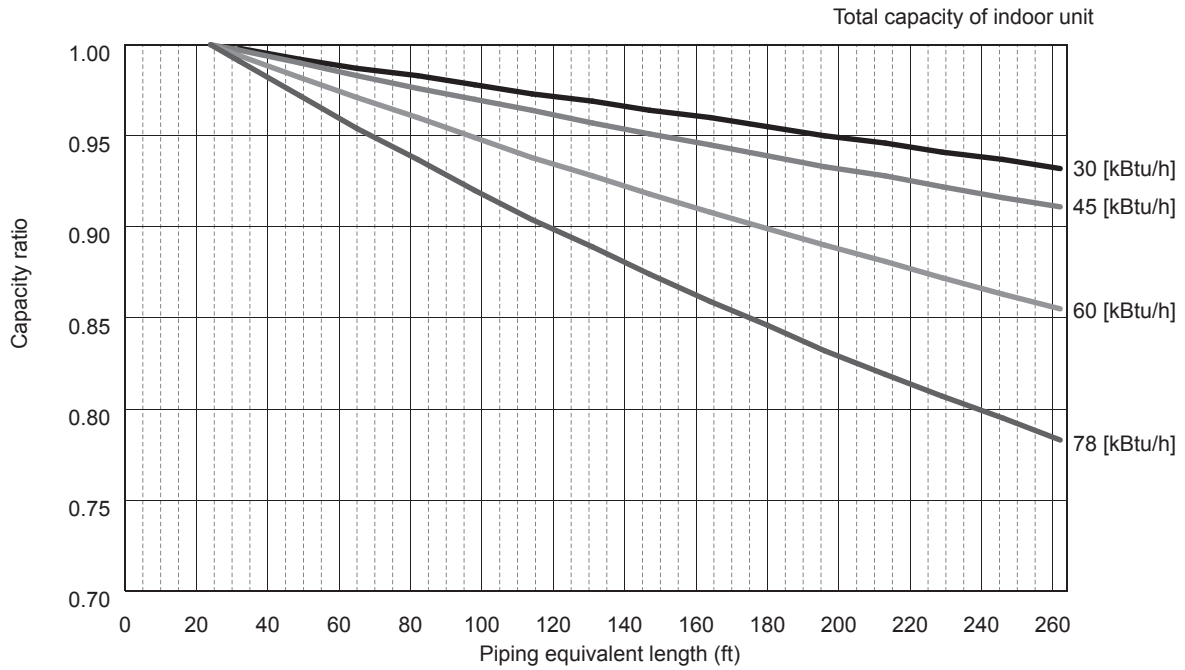

Figure 17 MXZ-SM36NAM-U1 MXZ-SM36NAMHZ-U1
 MXZ-SM42NAMHZ-U1
 MXZ-SM48NAM-U1 MXZ-SM48NAMHZ-U1 <Heating>
 Total capacity of indoor unit

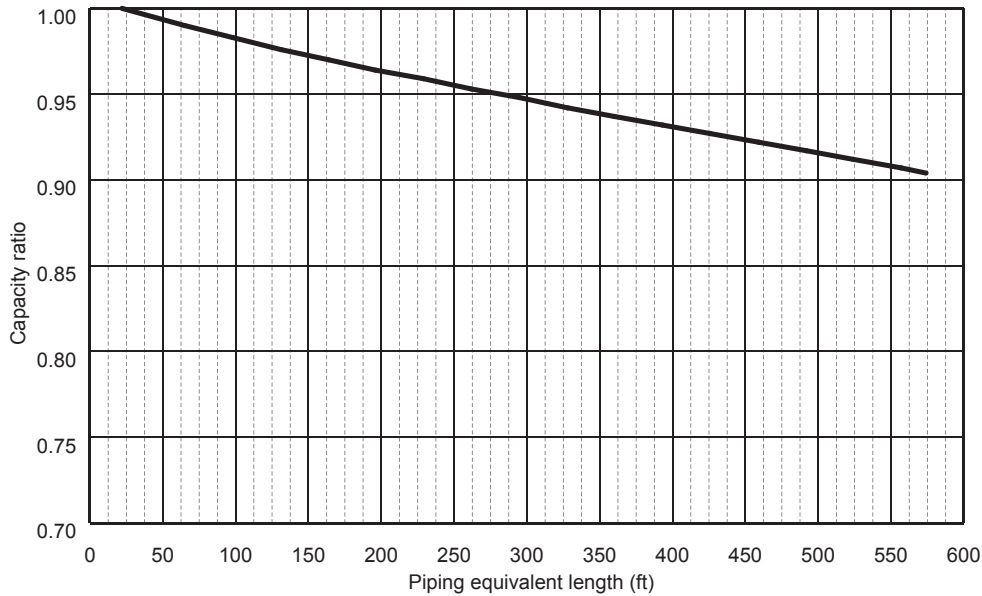
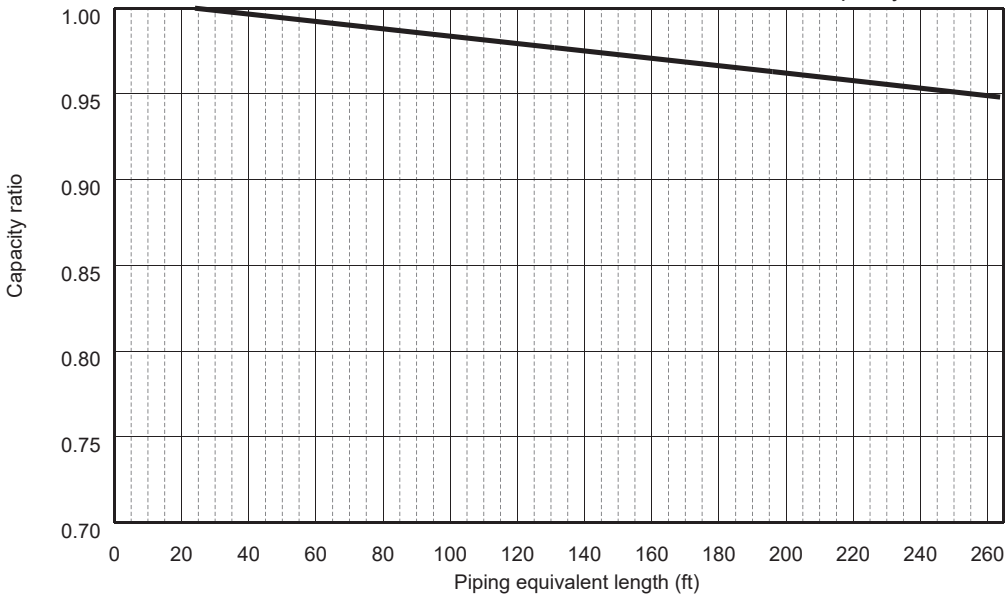

Figure 18 MXZ-SM60NAM-U1 <Heating>
 Total capacity of indoor unit



(2) Method for Obtaining the Equivalent Piping Length

Equivalent length = (length of piping to farthest indoor unit) + (0.3 x number of bends in the piping) (m)

4-5-1. Correction of Heating Capacity for Frost and Defrosting

If heating capacity has been reduced due to frost formation or defrosting, multiply the capacity by the appropriate correction factor from the following table to obtain the actual heating capacity.

Correction factor diagram

Outdoor Intake temperature <W.B. °F (°C)>	43(6)	37(4)	36(2)	32(0)	28(-2)	25(-4)	21(-6)	18(-8)	14(-10)	5(-15)	-4(-20)	-13(-25)
Correction factor	1.00	0.98	0.89	0.88	0.89	0.90	0.95	0.95	0.95	0.95	0.95	0.95

4-6. NOISE CRITERION CURVES

MXZ-SM36NAM-U1
MXZ-SM36NAMHZ-U1

MODE	SPL(dB)	LINE
COOLING	49	○—○
HEATING	53	●—●

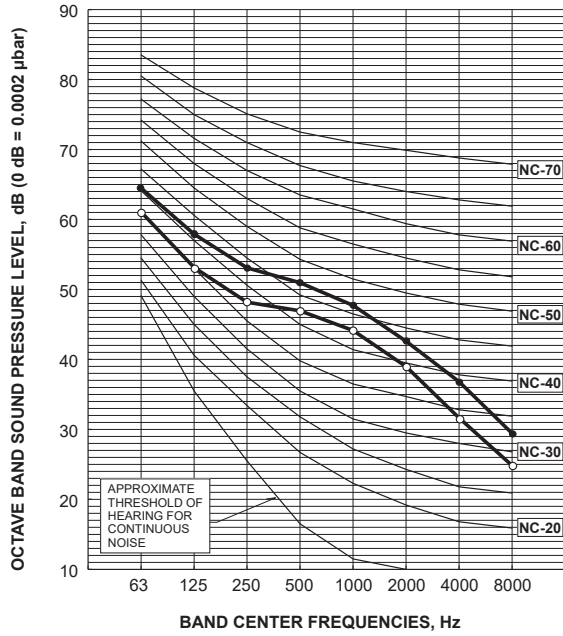

MXZ-SM42NAMHZ-U1

MODE	SPL(dB)	LINE
COOLING	50	○—○
HEATING	54	●—●

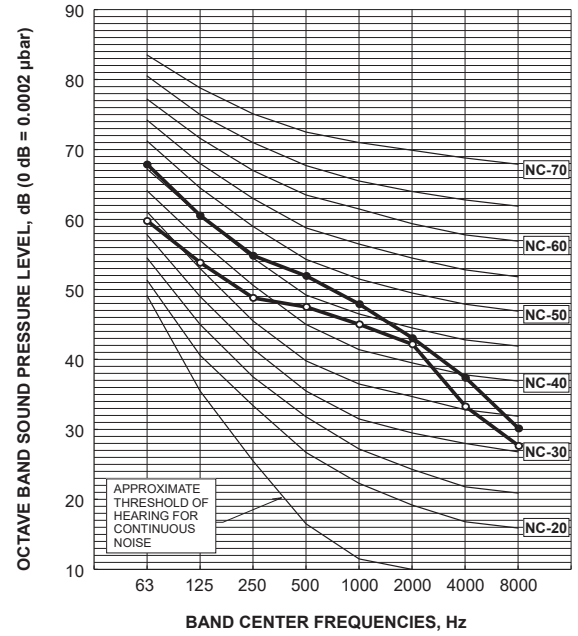

MXZ-SM48NAM-U1
MXZ-SM48NAMHZ-U1

MODE	SPL(dB)	LINE
COOLING	51	○—○
HEATING	54	●—●

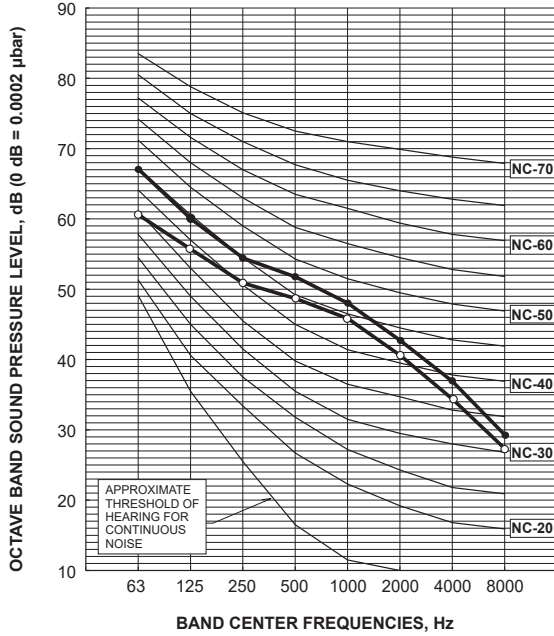

MXZ-SM60NAM-U1

MODE	SPL(dB)	LINE
COOLING	58	○—○
HEATING	59	●—●

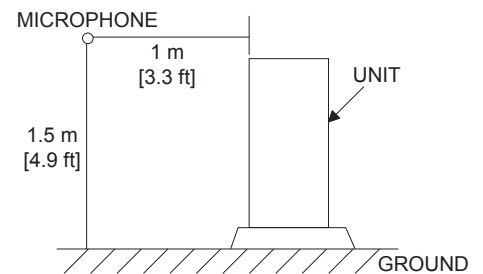
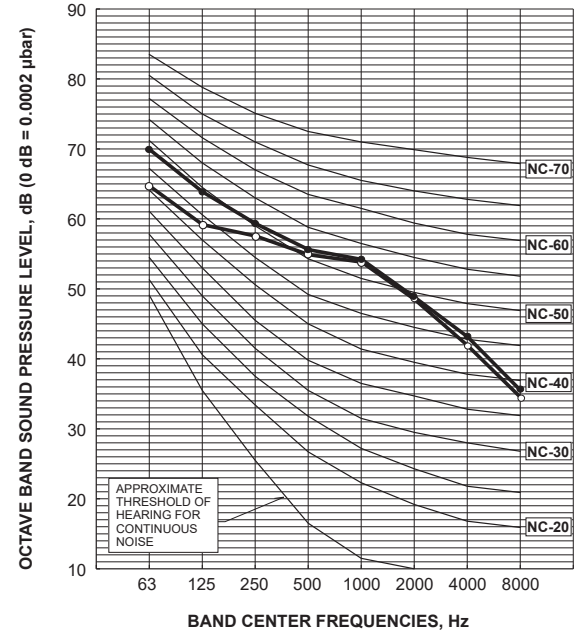

MXZ-SM36NAM-U1
MXZ-SM48NAM-U1

[LEGEND]

SYMBOL	NAME	SYMBOL	NAME	SYMBOL	NAME
TB1	Terminal Block (Power Supply)	TH7	Thermistor (Ambient)	SW5	Switch (Function Selection)
TB1B	Terminal Block (Branch Box)	TH8	Thermistor (Heat Sink)	SW6	Switch (Function Selection)
TB3	Terminal Block (Indoor/Outdoor, Branch Box/Outdoor Transmission Line)	LEV-A, LEV-B	Linear Expansion Valve	SW7	Switch (Function Selection)
TB7	Terminal Block (Centralized Control Transmission Line)	DCL1, DCL2, DCL3	Reactor	SW8	Switch (Model Selection)
FUSE1, FUSE2	Fuse (T20A L250V)	P.B.	Power Circuit Board	SW9	Switch (Function/Model Selection)
MC	Motor for Compressor	U/V/W	Connection Terminal (U/V/W-Phase)	SWU1	Switch (Unit Address Selection, ones digit)
MF1, MF2	Fan Motor	L1	Connection Terminal (L1-Phase)	SWU2	Switch (Unit Address Selection, tens digit)
21S4	Solenoid Valve Coil (4-Way Valve)	NI	Connection Terminal (L2-Phase)	SS	Connector (Connection for Option)
63H	High Pressure Switch	TA1A, TB2A, TB3A	Connection Terminal (Reactor)	CN3D	Connector (Connection for Option)
63HS	High Pressure Sensor	IC500	Converter	CN3S	Connector (Connection for Option)
63LS	Low Pressure Sensor	IC600	Inverter	CN3N	Connector (Connection for Option)
SV1	Solenoid Valve Coil (Bypass Valve)	E1, E2, E3, E4	Connection Terminal (Electrical Parts Box)	CN51	Connector (Connection for Option)
TH2	Thermistor (Hic Pipe)	MULTI.B.	Multi Controller Circuit Board	LED1, LED2	LED (Operation Inspection Display)
TH3	Thermistor (Outdoor Liquid Pipe)	SW1	Switch (Display Selection)	LED3	LED (Power Supply to Main Microcomputer)
TH4	Thermistor (Compressor)	SW2	Switch (Function/Model Selection)	F1, F2	Fuse (T6.3A L250V)
TH6	Thermistor (Suction Pipe)	SW3	Switch (Test Run)	X501~X505	Relay
		SW4	Switch (Model Selection)	M-NET P.B.	M-NET Power Circuit Board
				TB1	Connection Terminal (Electrical Parts Box)

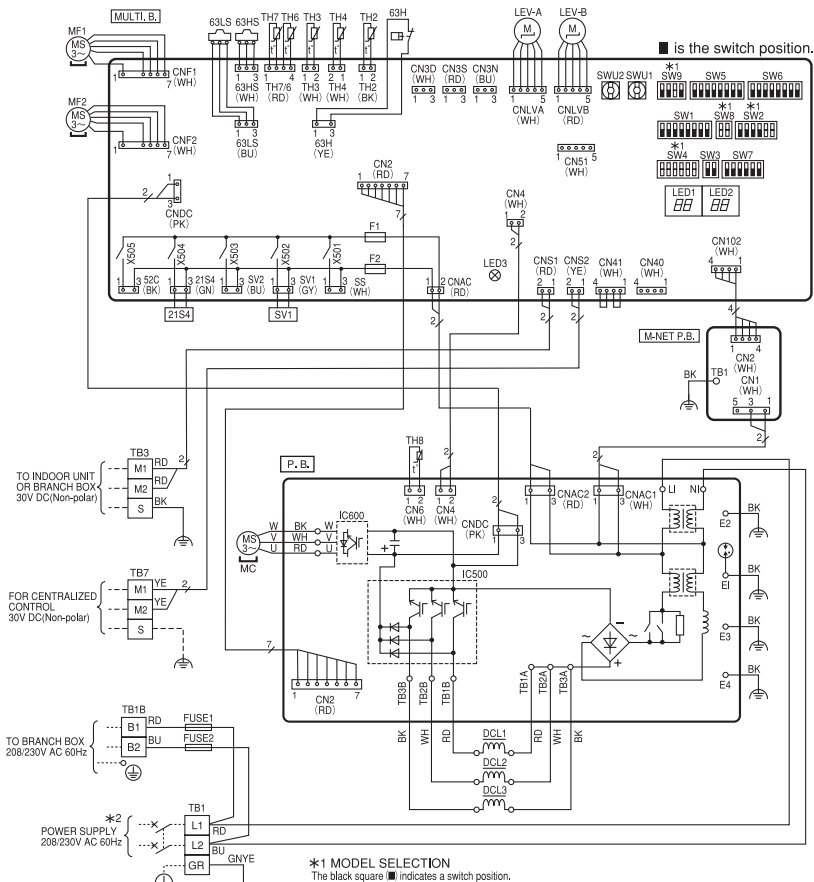

*1 MODEL SELECTION

The black square ■ indicates a switch position.

MODEL	SW2	SW4	SW8	SW9	MODEL	SW2	SW4	SW8	SW9
MXZ-SM36NAM	OFF	OFF	OFF	OFF	MXZ-SM48NAM	OFF	OFF	OFF	OFF

*2 Use copper supply wires.

Utiliser des fils d'alimentation en cuivre.

*3 When a branch box is connected,

SW2-5 should be ON.

Cautions when Servicing

- ⚠ WARNING: When the main supply is turned off, the voltage in the main capacitor will drop to 20 VDC in approx. 2 minutes. When servicing, make sure that LED1, LED2 on the outdoor multi controller circuit board goes out, and then wait for at least 1 minute.
- Components other than the outdoor circuit boards may be faulty: Check and take corrective action, referring to the service manual. Do not replace the outdoor circuit boards without checking.

NOTES:

1. Refer to the wiring diagrams of the indoor units for details on wiring of each indoor unit.

2. Self-diagnosis function

The indoor and outdoor units can be diagnosed automatically using the self-diagnosis switch (SW1) and LED indication (LED1, LED2) found on the outdoor multi controller circuit board.

LED indication: Set all contacts of SW1 to OFF.

- During normal operation
The LED indicates the drive state of outdoor unit.

Bit	1	2	3	4	5	6	7	8
Indication	Compressor operated	52C	21S4	SV1	(SV2)	—	—	Always lit

- When fault requiring inspection has occurred
The LED alternately indicates the check code and the address of the unit in which the fault has occurred.

[Example]

When the compressor and SV1 are on during cooling operation.



MXZ-SM60NAM-U1

[LEGEND]

SYMBOL	NAME	SYMBOL	NAME	SYMBOL	NAME
TB1	Terminal Block (Power Supply)	LEV-A, LEV-B	Linear Expansion Valve	SW5	Switch (Function Selection)
TB1B	Terminal Block (Branch Box)	DCL1, DCL2, DCL3	Reactor	SW6	Switch (Function Selection)
TB3	Terminal Block (Indoor/Outdoor, Branch Box/Outdoor Transmission Line)	N.F.	Noise Filter Board	SW7	Switch (Function Selection)
TB7	Terminal Block (Centralized Control Transmission Line)	LI	Connection Terminal (L1-Phase)	SW8	Switch (Model Selection)
FUSE1, FUSE2	Fuse (T20A L250V)	NI	Connection Terminal (L2-Phase)	SW9	Switch (Function/Model Selection)
MC	Motor for Compressor	TB1, TB2	Connection Terminal (Power Circuit Board)	SWU1	Switch (Unit Address Selection, ones digit)
MF1, MF2	Fan Motor	E1, E2, E3, E4	Connection Terminal (Electrical Parts Box)	SWU2	Switch (Unit Address Selection, tens digit)
21S4	Solenoid Valve Coil (4-Way Valve)	P.B.	Power Circuit Board	SS	Connector (Connection for Option)
63H	High Pressure Switch	TB3, TB4	Connection Terminal (Noise Filter Board)	CN3D	Connector (Connection for Option)
63HS	High Pressure Sensor	U/V/W	Connection Terminal (U/V/W-Phase)	CN3S	Connector (Connection for Option)
63LS	Low Pressure Sensor	TB1A, TB2A, TB3A, TB1B, TB2B, TB3B	Connection Terminal (Reactor)	CN3N	Connector (Connection for Option)
SV1	Solenoid Valve Coil (Bypass Valve)	E5	Connection Terminal (Electrical Parts Box)	CN51	Connector (Connection for Option)
TH2	Thermistor (Hic Pipe)	IC500	Converter	LED1, LED2	LED (Operation Inspection Display)
TH3	Thermistor (Outdoor Liquid Pipe)	IC600	Inverter	LED3	LED (Power Supply to Main Microcomputer)
TH4	Thermistor (Compressor)	MULTL.B.	Multi Controller Circuit Board	F1, F2	Fuse (T6.3A L250V)
TH6	Thermistor (Suction Pipe)	SW1	Switch (Display Selection)	X501~X505	Relay
TH7	Thermistor (Ambient)	SW2	Switch (Function/Model Selection)	M-NET P.B.	M-NET Power Circuit Board
TH8	Thermistor (Heat Sink)	SW3	Switch (Test Run)	TB1	Connection Terminal (Electrical Parts Box)
		SW4	Switch (Model Selection)		

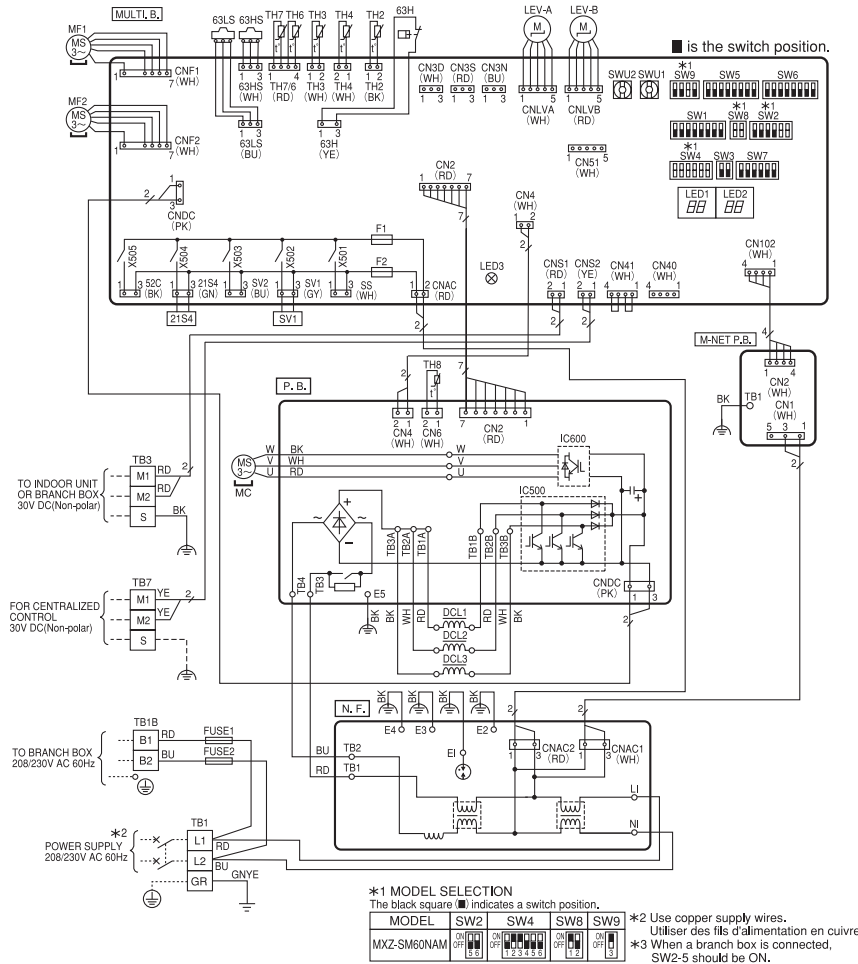

Cautions when Servicing

- ⚠ **WARNING:** When the main supply is turned off, the voltage in the main capacitor will drop to 20 VDC in approx. 2 minutes. When servicing, make sure that LED1, LED2 on the outdoor multi controller circuit board goes out, and then wait for at least 1 minute.
- Components other than the outdoor circuit boards may be faulty: Check and take corrective action, referring to the service manual. Do not replace the outdoor circuit boards without checking.

NOTES:

- Refer to the wiring diagrams of the indoor units for details on wiring of each indoor unit.
- Self-diagnosis function

The indoor and outdoor units can be diagnosed automatically using the self-diagnosis switch (SW1) and LED indication (LED1, LED2) found on the outdoor multi controller circuit board. LED indication : Set all contacts of SW1 to OFF.

- During normal operation
The LED indicates the drive state of outdoor unit.

Bit	1	2	3	4	5	6	7	8
Indication	Compressor operated	52C	21S4	SV1	(SV2)	—	—	Always lit

- When fault requiring inspection has occurred
The LED alternately indicates the check code and the address of the unit in which the fault has occurred.

[Example]
When the compressor and SV1 are on during cooling operation.



MXZ-SM36NAMHZ-U1

MXZ-SM42NAMHZ-U1

MXZ-SM48NAMHZ-U1

[LEGEND]

SYMBOL	NAME	SYMBOL	NAME	SYMBOL	NAME
TB1	Terminal Block (Power Supply)	TH7	Thermistor (Ambient)	SW4	Switch (Model Selection)
TB1B	Terminal Block (Branch Box)	TH8	Thermistor (Heat Sink)	SW5	Switch (Function Selection)
TB3	Terminal Block (Indoor/Outdoor, Branch Box/Outdoor Transmission Line)	LEV-A, LEV-B	Linear Expansion Valve	SW6	Switch (Function Selection)
TB7	Terminal Block (Centralized Control Transmission Line)	DCL1, DCL2, DCL3	Reactor	SW7	Switch (Function Selection)
FUSE1, FUSE2	Fuse (T20A L250V)	N.F.	Noise Filter Board	SW8	Switch (Model Selection)
MC	Motor for Compressor	LI	Connection Terminal (L1-Phase)	SW9	Switch (Function/Model Selection)
MF1, MF2	Fan Motor	NI	Connection Terminal (L2-Phase)	SWU1	Switch (Unit Address Selection, ones digit)
21S4	Solenoid Valve Coil (4-Way Valve)	TB1, TB2	Connection Terminal (Power Circuit Board)	SWU2	Switch (Unit Address Selection, tens digit)
63H	High Pressure Switch	E1, E2, E3, E4	Connection Terminal (Electrical Parts Box)	SS	Connector (Connection for Option)
63HS	High Pressure Sensor	P.B.	Power Circuit Board	CN3D	Connector (Connection for Option)
63LS	Low Pressure Sensor	TB3, TB4	Connection Terminal (Noise Filter Board)	CN3S	Connector (Connection for Option)
SV1	Solenoid Valve Coil (Bypass Valve)	U/V/W	Connection Terminal (U/V/W-Phase)	CN3N	Connector (Connection for Option)
SV2	Solenoid Valve Coil (Switching Valve)	TB1A, TB2A, TB3A, TB1B, TB2B, TB3B	Connection Terminal (Reactor)	CN51	Connector (Connection for Option)
BH	Base Heater	E5	Connection Terminal (Electrical Parts Box)	LED1, LED2	LED (Operation Inspection Display)
THP	Thermal Protector	IC500	Converter	LED3	LED (Power Supply to Main Microcomputer)
TH2	Thermistor (Hic Pipe)	IC600	Inverter	F1, F2	Fuse (T6,3A L250V)
TH3	Thermistor (Outdoor Liquid Pipe)	MULTLB.	Multi Controller Circuit Board	X501~X505	Relay
TH4	Thermistor (Compressor)	SW1	Switch (Display Selection)	M-NET P.B.	M-NET Power Circuit Board
TH6	Thermistor (Suction Pipe)	SW2	Switch (Function/Model Selection)	TB1	Connection Terminal (Electrical Parts Box)
		SW3	Switch (Test Run)		

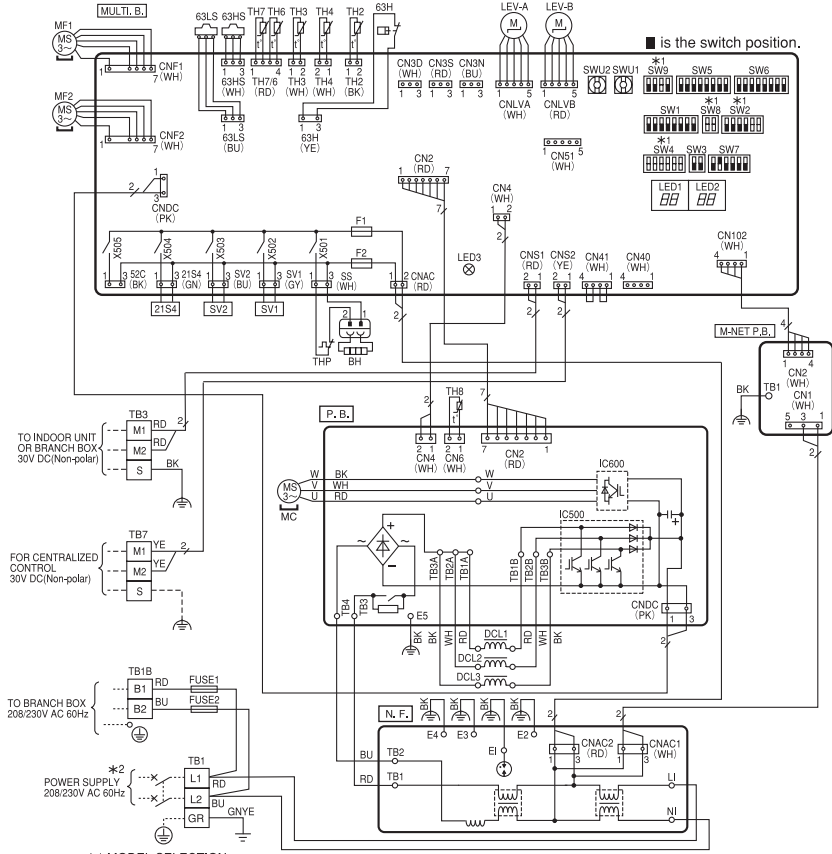

*1 MODEL SELECTION

The black square ■ indicates a switch position.

MODEL	SW2	SW4	SW8	SW9	MODEL	SW2	SW4	SW8	SW9	MODEL	SW2	SW4	SW8	SW9
MXZ-SM36NAMHZ	ON	OFF	OFF	OFF	MXZ-SM42NAMHZ	ON	OFF	OFF	OFF	MXZ-SM48NAMHZ	ON	OFF	OFF	OFF

*2 Use copper supply wires.
Utiliser des fils d'alimentation en cuivre.

*3 When a branch box is connected, SW2-5 should be ON.

Cautions when Servicing

- ⚠ **WARNING:** When the main supply is turned off, the voltage in the main capacitor will drop to 20 VDC in approx. 2 minutes. When servicing, make sure that LED1, LED2 on the outdoor multi controller circuit board goes out, and then wait for at least 1 minute.
- Components other than the outdoor circuit boards may be faulty: Check and take corrective action, referring to the service manual. Do not replace the outdoor circuit boards without checking.

NOTES:

- Refer to the wiring diagrams of the indoor units for details on wiring of each indoor unit.
- Self-diagnosis function

The indoor and outdoor units can be diagnosed automatically using the self-diagnosis switch (SW1) and LED indication (LED1, LED2) found on the outdoor multi controller circuit board.
LED indication : Set all contacts of SW1 to OFF.

- During normal operation
The LED indicates the drive state of outdoor unit.

Bit	1	2	3	4	5	6	7	8
Indication	Compressor operated	52C	21S4	SV1	SV2	—	—	Always lit

- When fault requiring inspection has occurred
The LED alternately indicates the check code and the address of the unit in which the fault has occurred.

[Example]

When the compressor and SV1 are on during cooling operation.

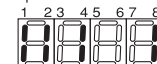

7-1. TRANSMISSION SYSTEM SETUP

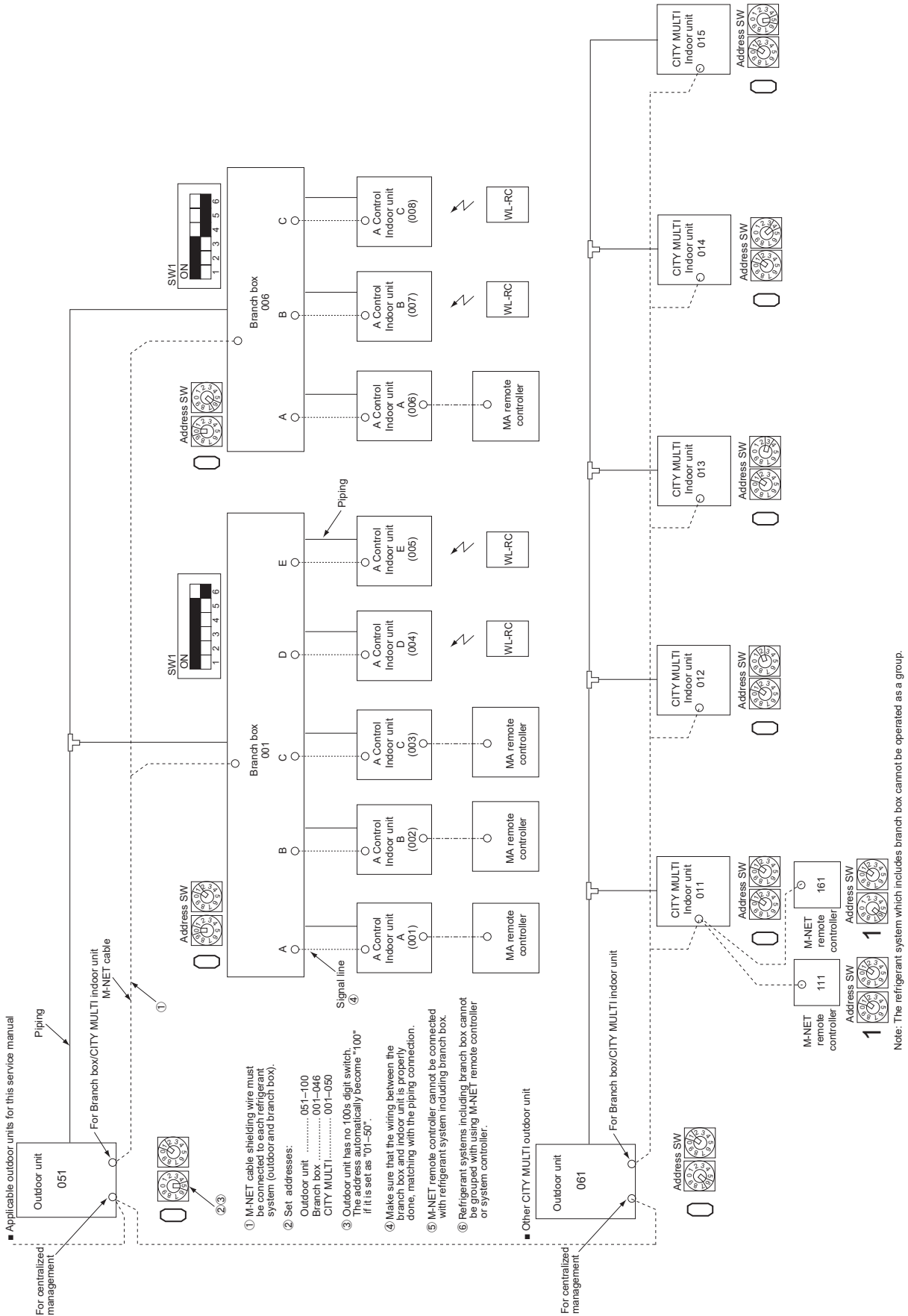

- ① M-NET cable shielding wire must be connected to each refrigerant system (outdoor and branch box).
- ② Set addresses:
Outdoor unit 051-100
Branch box 001-046
CITY MULTI 001-050
- ③ Outdoor unit has no 100s digit switch. The address automatically become "100" if it is set as "01-50".
- ④ Make sure that the wiring between the branch box and indoor unit is properly done, matching with the piping connection.
- ⑤ M-NET remote controller cannot be connected with refrigerant system including branch box.
- ⑥ Refrigerant systems including branch box cannot be grouped when using M-NET remote controller on system controller.

7-2. Special Function Operation and Settings for M-NET Remote Controller

For the detailed procedure of "group settings" and "paired settings", refer to the remote controller's manuals.

7-3. REFRIGERANT SYSTEM DIAGRAM

MXZ-SM36NAM-U1 MXZ-SM48NAM-U1

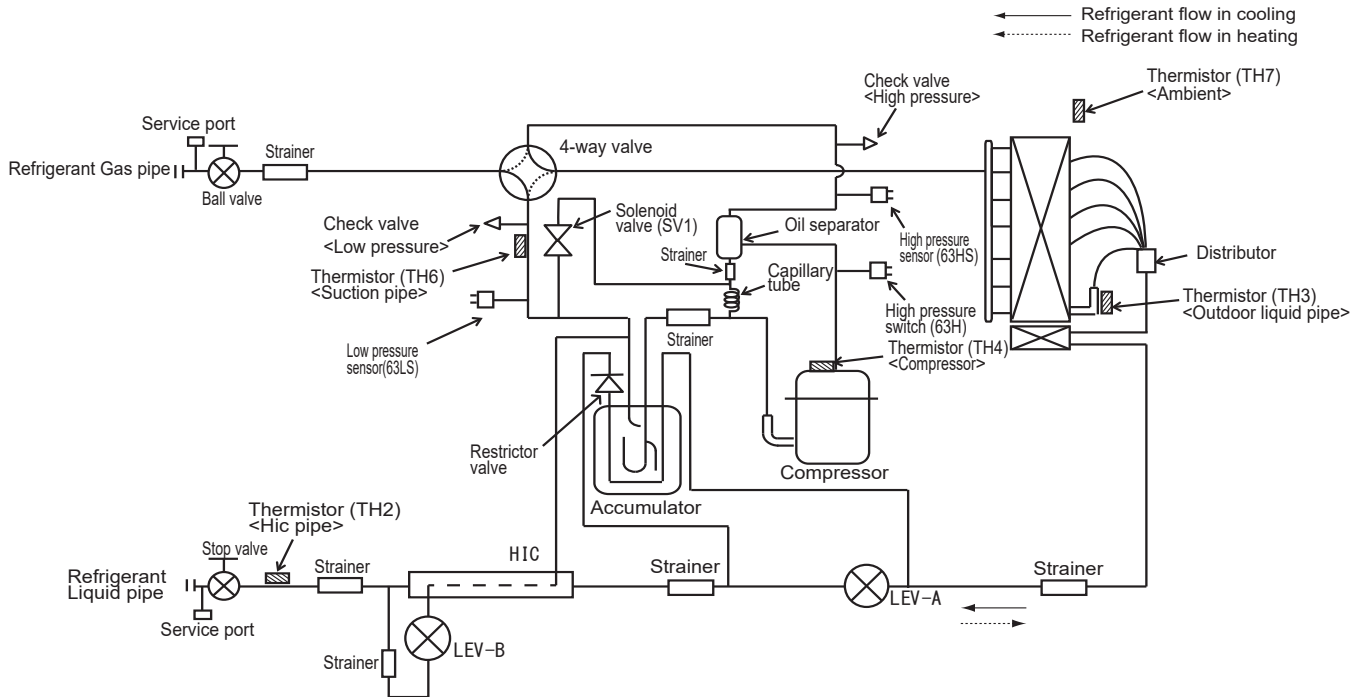

Capillary tube for oil separator [inch(mm)]: $\phi 0.098 \times \phi 0.031 \times L39.37$ ($\phi 2.5 \times \phi 0.8 \times L1000$)

MXZ-SM36NAMHZ-U1
MXZ-SM42NAMHZ-U1
MXZ-SM48NAMHZ-U1

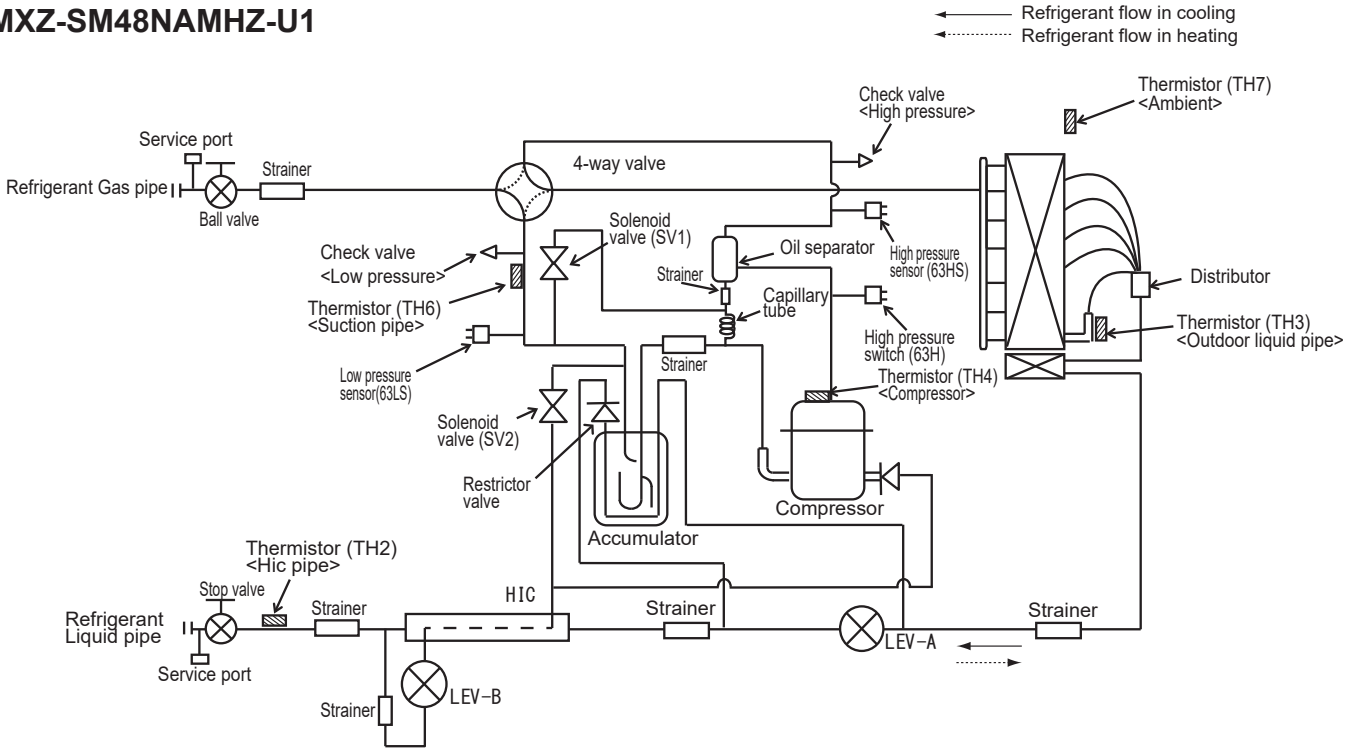

Capillary tube for oil separator [inch(mm)]: $\varnothing 0.098 \times \varnothing 0.031 \times L39.37$ ($\varnothing 2.5 \times \varnothing 0.8 \times L1000$)

MXZ-SM60NAM-U1

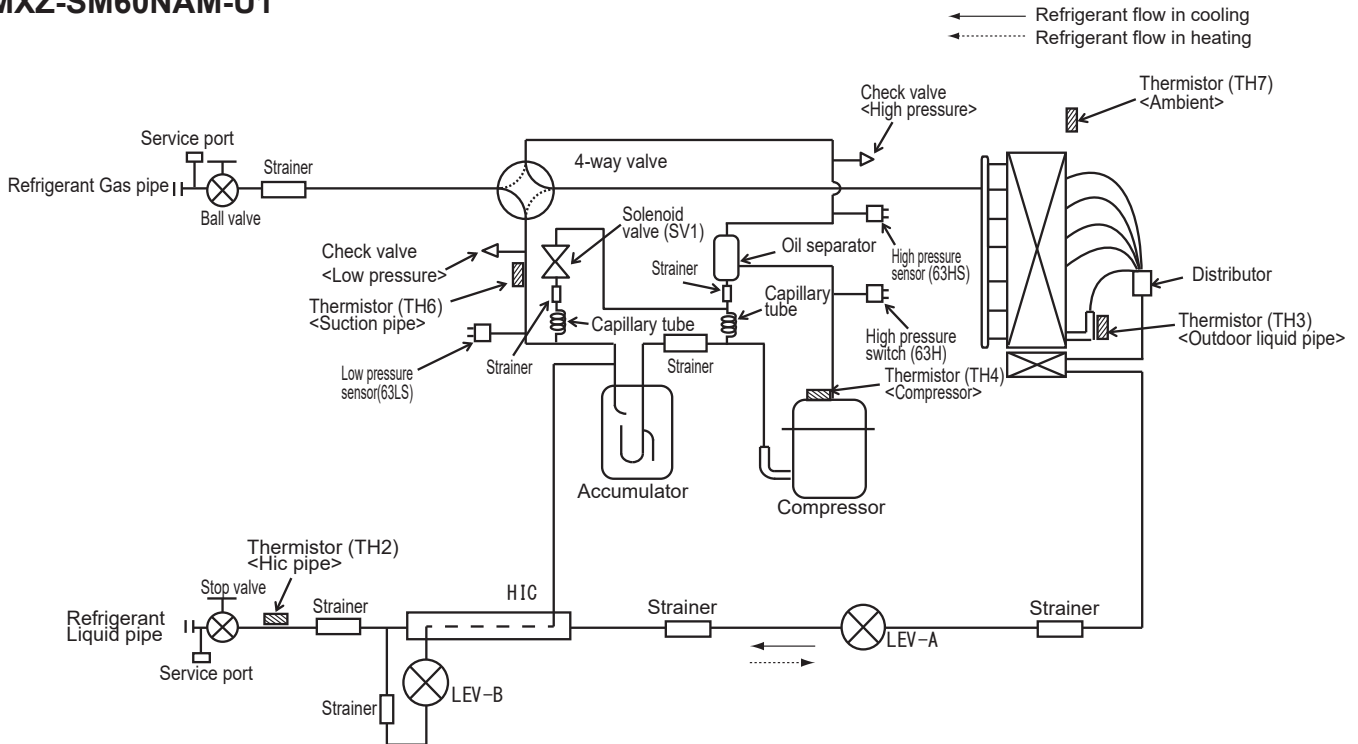

Capillary tube for oil separator [inch(mm)]: $\varnothing 0.098 \times \varnothing 0.031 \times L31.50$ ($\varnothing 2.5 \times \varnothing 0.8 \times L800$)

Capillary tube for solenoid valve [inch(mm)]: $\varnothing 0.157 \times \varnothing 0.117 \times L19.685$ ($\varnothing 4.0 \times \varnothing 3.0 \times L500$)

MXZ-SM36NAM-U1

MXZ-SM48NAM-U1

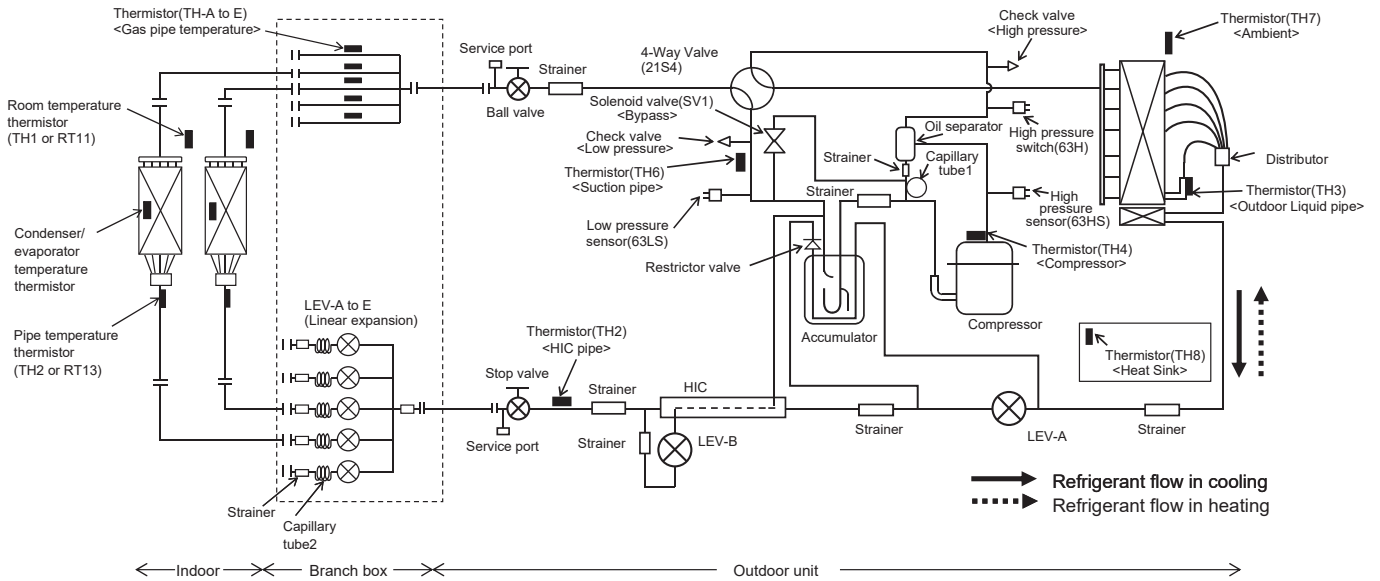

Unit: inch (mm)

	Capillary tube 1 (For return of oil from oil separator)	Capillary tube 2 behind LEV (in cooling mode)
Outdoor unit	$\varnothing 0.098 \times \varnothing 0.031 \times L(39-1/2)$ ($\varnothing 2.5 \times \varnothing 0.8 \times L1000$)	—
Branch box	—	$(\varnothing 0.157 \times \varnothing 0.117 \times L(5-1/8)) \times 5$ ($(\varnothing 4.0 \times \varnothing 3.0 \times L130) \times 5$)
	—	$(\varnothing 0.157 \times \varnothing 0.117 \times L(5-1/8)) \times 3$ ($(\varnothing 4.0 \times \varnothing 3.0 \times L130) \times 3$)

MXZ-SM36NAMHZ-U1

MXZ-SM42NAMHZ-U1

MXZ-SM48NAMHZ-U1

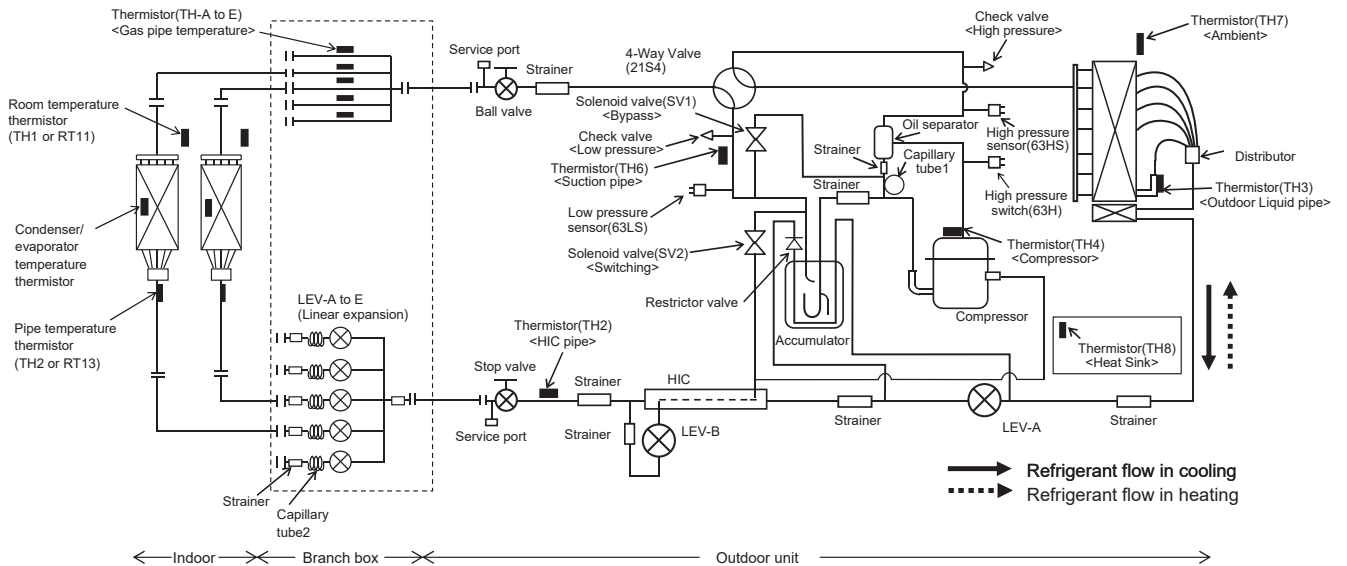

Unit: inch (mm)

	Capillary tube 1 (For return of oil from oil separator)	Capillary tube 2 behind LEV (in cooling mode)
Outdoor unit	$\varnothing 0.098 \times \varnothing 0.031 \times L(39-1/2)$ ($\varnothing 2.5 \times \varnothing 0.8 \times L1000$)	—
Branch box	—	$(\varnothing 0.157 \times \varnothing 0.117 \times L(5-1/8)) \times 5$ ($(\varnothing 4.0 \times \varnothing 3.0 \times L130) \times 5$)
	—	$(\varnothing 0.157 \times \varnothing 0.117 \times L(5-1/8)) \times 3$ ($(\varnothing 4.0 \times \varnothing 3.0 \times L130) \times 3$)

MXZ-SM60NAM-U1

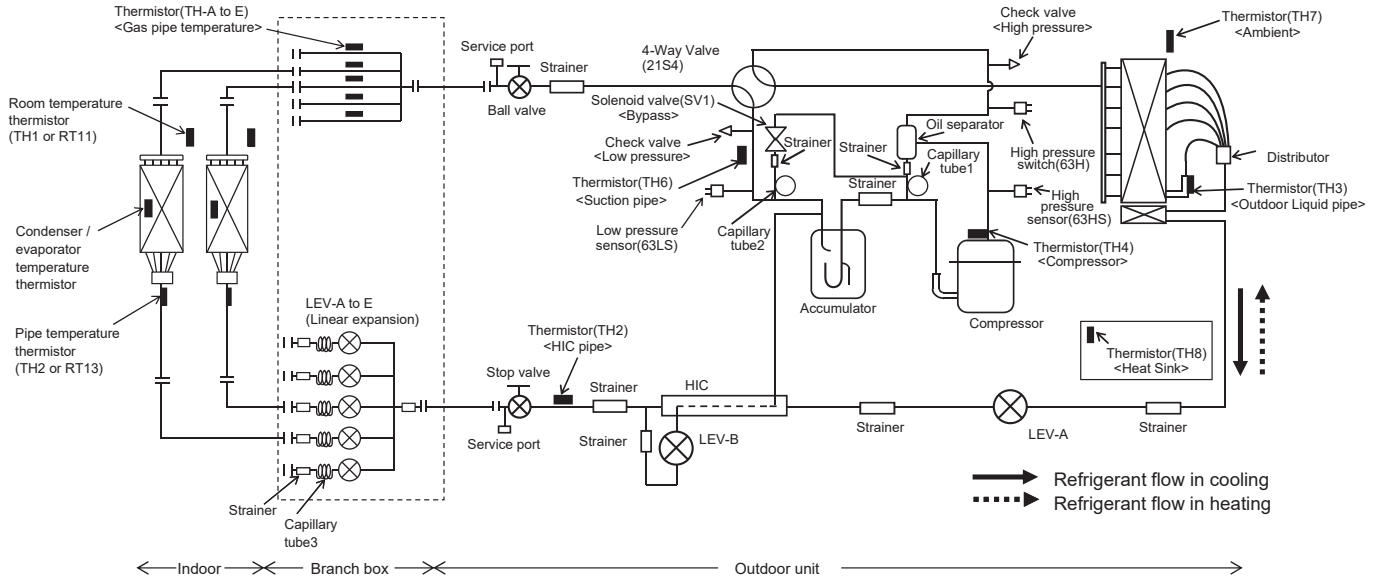

Unit: inch (mm)

	Capillary tube 1 (For return of oil from oil separator)	Capillary tube 2 (For solenoid valve (SV1))	Capillary tube 3 behind LEV (in cooling mode)
Outdoor unit	$\varnothing 0.098 \times \varnothing 0.031 \times L(39-1/2)$ ($\varnothing 2.5 \times \varnothing 0.8 \times L800$)	$\varnothing 0.157 \times \varnothing 0.117 \times L(19-5/8)$ ($\varnothing 4.0 \times \varnothing 3.0 \times L500$)	—
Branch box	—	—	$(\varnothing 0.157 \times \varnothing 0.117 \times L(5-1/8)) \times 5$ $((\varnothing 4.0 \times \varnothing 3.0 \times L130) \times 5)$
	—	—	$(\varnothing 0.157 \times \varnothing 0.117 \times L(5-1/8)) \times 3$ $((\varnothing 4.0 \times \varnothing 3.0 \times L130) \times 3)$

7-4. SYSTEM CONTROL

7-4-1. Example for the System

- Example for wiring control cables, wiring method and address setting, permissible lengths, and the constraint items are listed in the standard system with detailed explanation.

A. Example of an M-NET remote controller system (address setting is necessary.)

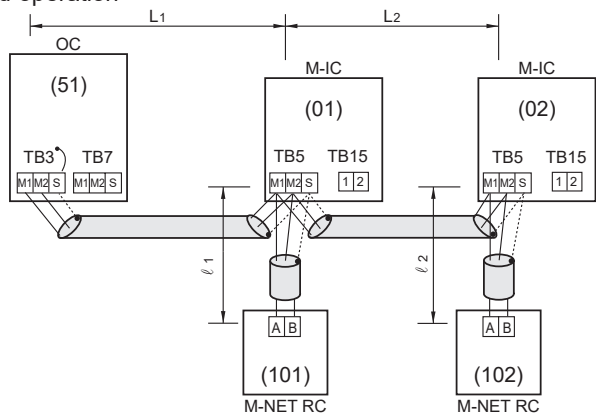
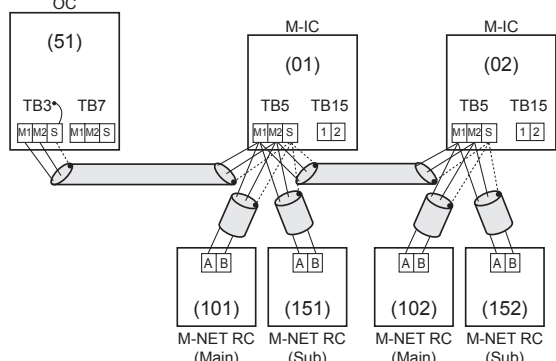
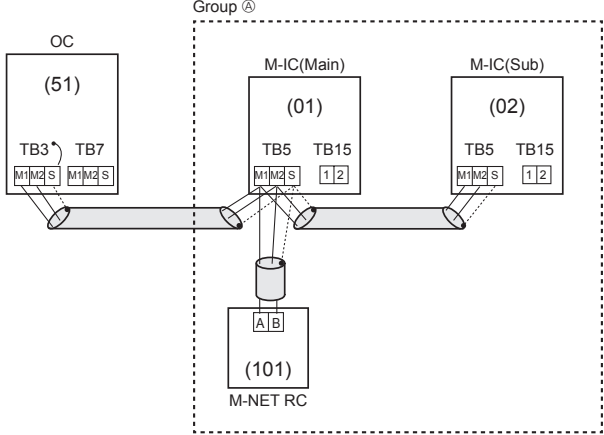
Example of wiring control cables	Wiring Method and Address Setting															
<p>1. Standard operation</p>  <ul style="list-style-type: none"> • 1 M-NET remote controller for each CITY MULTI series indoor unit • There is no need for setting the 100 position on the M-NET remote controller. 	<p>a. Use feed wiring to connect terminals M1 and M2 on transmission cable block (TB3) for the outdoor unit (OC) to terminals M1 and M2 on the transmission cable block (TB5) of each CITY MULTI series indoor unit (M-IC). Use non-polarized 2-core wire.</p> <p>b. Connect terminals M1 and M2 on transmission cable terminal block (TB5) for each indoor unit with the terminal block (TB6) for M-NET the remote controller (M-NET RC).</p> <p>c. Set the address setting switch (on outdoor unit P.C.B) as shown below.</p> <table border="1" data-bbox="917 659 1520 872"> <thead> <tr> <th>Unit</th> <th>Range</th> <th>Setting Method</th> </tr> </thead> <tbody> <tr> <td>CITY MULTI series indoor unit (M-IC)</td> <td>001 to 050</td> <td>—</td> </tr> <tr> <td>Outdoor unit (OC)</td> <td>051 to 100</td> <td>Use the smallest address of all the indoor unit plus 50.</td> </tr> <tr> <td>M-NET Remote controller (M-NET RC)</td> <td>101 to 150</td> <td>Indoor unit address plus 100</td> </tr> </tbody> </table>	Unit	Range	Setting Method	CITY MULTI series indoor unit (M-IC)	001 to 050	—	Outdoor unit (OC)	051 to 100	Use the smallest address of all the indoor unit plus 50.	M-NET Remote controller (M-NET RC)	101 to 150	Indoor unit address plus 100			
Unit	Range	Setting Method														
CITY MULTI series indoor unit (M-IC)	001 to 050	—														
Outdoor unit (OC)	051 to 100	Use the smallest address of all the indoor unit plus 50.														
M-NET Remote controller (M-NET RC)	101 to 150	Indoor unit address plus 100														
<p>2. Operation using 2 M-NET remote controllers</p>  <ul style="list-style-type: none"> • Using 2 M-NET remote controllers for each CITY MULTI series indoor unit. 	<p>a. Same as above 1.a</p> <p>b. Same as above 1.b</p> <p>c. Set address switch (on outdoor unit P.C.B) as shown below.</p> <table border="1" data-bbox="917 1000 1520 1298"> <thead> <tr> <th>Unit</th> <th>Range</th> <th>Setting Method</th> </tr> </thead> <tbody> <tr> <td>CITY MULTI series indoor unit (M-IC)</td> <td>001 to 050</td> <td>—</td> </tr> <tr> <td>Outdoor unit (OC)</td> <td>051 to 100</td> <td>Use the smallest address of all the indoor units plus 50.</td> </tr> <tr> <td>Main M-NET Remote Controller (M-NET RC)</td> <td>101 to 150</td> <td>Indoor unit address plus 100</td> </tr> <tr> <td>Sub M-NET Remote Controller (M-NET RC)</td> <td>151 to 200</td> <td>Indoor unit address plus 150</td> </tr> </tbody> </table>	Unit	Range	Setting Method	CITY MULTI series indoor unit (M-IC)	001 to 050	—	Outdoor unit (OC)	051 to 100	Use the smallest address of all the indoor units plus 50.	Main M-NET Remote Controller (M-NET RC)	101 to 150	Indoor unit address plus 100	Sub M-NET Remote Controller (M-NET RC)	151 to 200	Indoor unit address plus 150
Unit	Range	Setting Method														
CITY MULTI series indoor unit (M-IC)	001 to 050	—														
Outdoor unit (OC)	051 to 100	Use the smallest address of all the indoor units plus 50.														
Main M-NET Remote Controller (M-NET RC)	101 to 150	Indoor unit address plus 100														
Sub M-NET Remote Controller (M-NET RC)	151 to 200	Indoor unit address plus 150														
<p>3. Group operation</p>  <ul style="list-style-type: none"> • Multiple CITY MULTI series indoor units operated together by 1 M-NET remote controller <p>Combinations of 1 through 3 above are possible.</p>	<p>a. Same as above 1.a</p> <p>b. Connect terminals M1 and M2 on transmission cable terminal block (TB5) of the M-IC main unit with the most recent address within the same CITY MULTI series indoor unit (M-IC) group to terminal block (TB6) on the M-NET remote controller.</p> <p>c. Set the address setting switch (on outdoor unit P.C.B) as shown below.</p> <table border="1" data-bbox="917 1553 1520 1904"> <thead> <tr> <th>Unit</th> <th>Range</th> <th>Setting Method</th> </tr> </thead> <tbody> <tr> <td>M-IC (Main)</td> <td>001 to 050</td> <td>Use the smallest address within the same group of CITY MULTI series indoor units.</td> </tr> <tr> <td>M-IC (Sub)</td> <td>001 to 050</td> <td>Use an address, other than that of the M-IC (Main) from among the units within the same group of indoor units. This must be in sequence with the M-IC (Main).</td> </tr> <tr> <td>Outdoor unit</td> <td>051 to 100</td> <td>Use the smallest address of all the CITY MULTI series indoor units plus 50.</td> </tr> <tr> <td>Main M-NET Remote Controller (M-NET RC)</td> <td>101 to 150</td> <td>Set at an M-IC (Main) address within the same group plus 100.</td> </tr> </tbody> </table> <p>d. Use the CITY MULTI series indoor unit (M-IC) within the group with the most functions as the M-IC (Main) unit.</p>	Unit	Range	Setting Method	M-IC (Main)	001 to 050	Use the smallest address within the same group of CITY MULTI series indoor units.	M-IC (Sub)	001 to 050	Use an address, other than that of the M-IC (Main) from among the units within the same group of indoor units. This must be in sequence with the M-IC (Main).	Outdoor unit	051 to 100	Use the smallest address of all the CITY MULTI series indoor units plus 50.	Main M-NET Remote Controller (M-NET RC)	101 to 150	Set at an M-IC (Main) address within the same group plus 100.
Unit	Range	Setting Method														
M-IC (Main)	001 to 050	Use the smallest address within the same group of CITY MULTI series indoor units.														
M-IC (Sub)	001 to 050	Use an address, other than that of the M-IC (Main) from among the units within the same group of indoor units. This must be in sequence with the M-IC (Main).														
Outdoor unit	051 to 100	Use the smallest address of all the CITY MULTI series indoor units plus 50.														
Main M-NET Remote Controller (M-NET RC)	101 to 150	Set at an M-IC (Main) address within the same group plus 100.														

• Name, Symbol and the Maximum Remote controller Units for Connection

Name	Symbol	Maximum units for connection
Outdoor unit	OC	—
CITY MULTI series indoor unit	M-IC	Refer to "3. SPECIFICATIONS".
M-NET remote controller	M-NET RC	Maximum 2 M-NET RC for 1 indoor unit, Maximum 12 M-NET RC for 1 OC

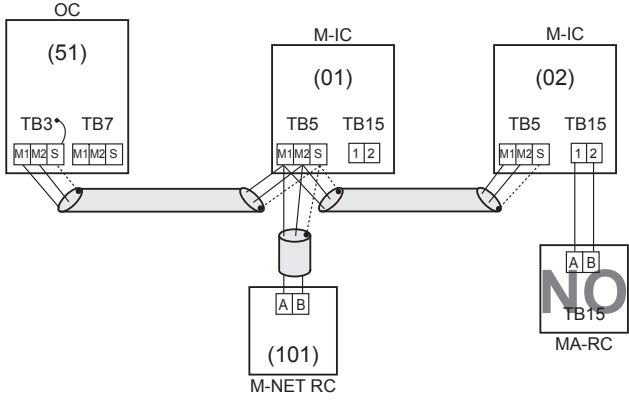
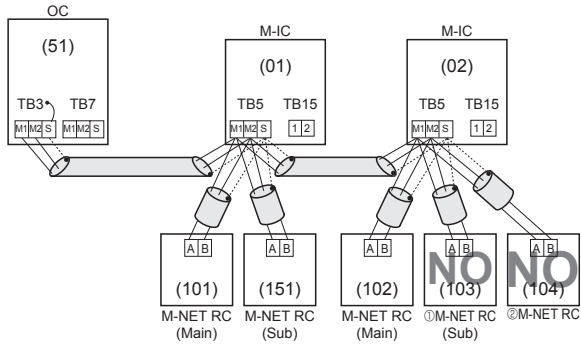
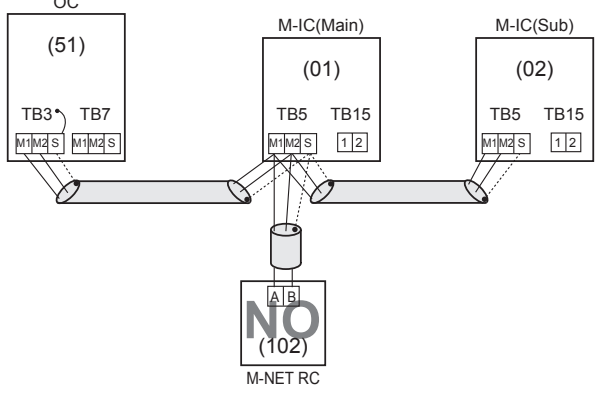
Permissible Lengths	Constraint items
<p>Indoor/outdoor transmission line</p> <p>Maximum length</p> <p>AWG 16 [1.25 mm²]</p> <p>L1 + L2 [656 ft [200 m]</p> <p>M-NET Remote controller cable length</p> <p>1. If AWG 20 to AWG 16 [0.5 to 1.25 mm²]</p> <p>R1, R2 [33ft [10 m]</p> <p>2. If the length exceeds 33ft [10 m], the exceeding section should be AWG 16 [1.25 mm²] and that section should be a value within the total extension length of the transmission cable and maximum transmission cable length. (L3)</p>	<ul style="list-style-type: none"> M-NET remote controller (M-NET RC) and MA remote controller (MA RC) cannot be used together. Do not connect anything with TB15 of CITY MULTI series indoor unit (M-IC). 
Same as above	 <ol style="list-style-type: none"> Use the CITY MULTI series indoor unit (M-IC) address plus 150 as the sub M-NET remote controller address. In this case, it should be 152. 3 or more M-NET remote controllers (M-NET RC) cannot be connected to 1 CITY MULTI series indoor unit.
Same as above	 <ol style="list-style-type: none"> The M-NET remote controller address is the CITY MULTI series indoor unit main address plus 100. In this case, it should be 101.

B. Example of a group operation system with 2 or more outdoor units and an M-NET remote controller.

(Address settings are necessary.)

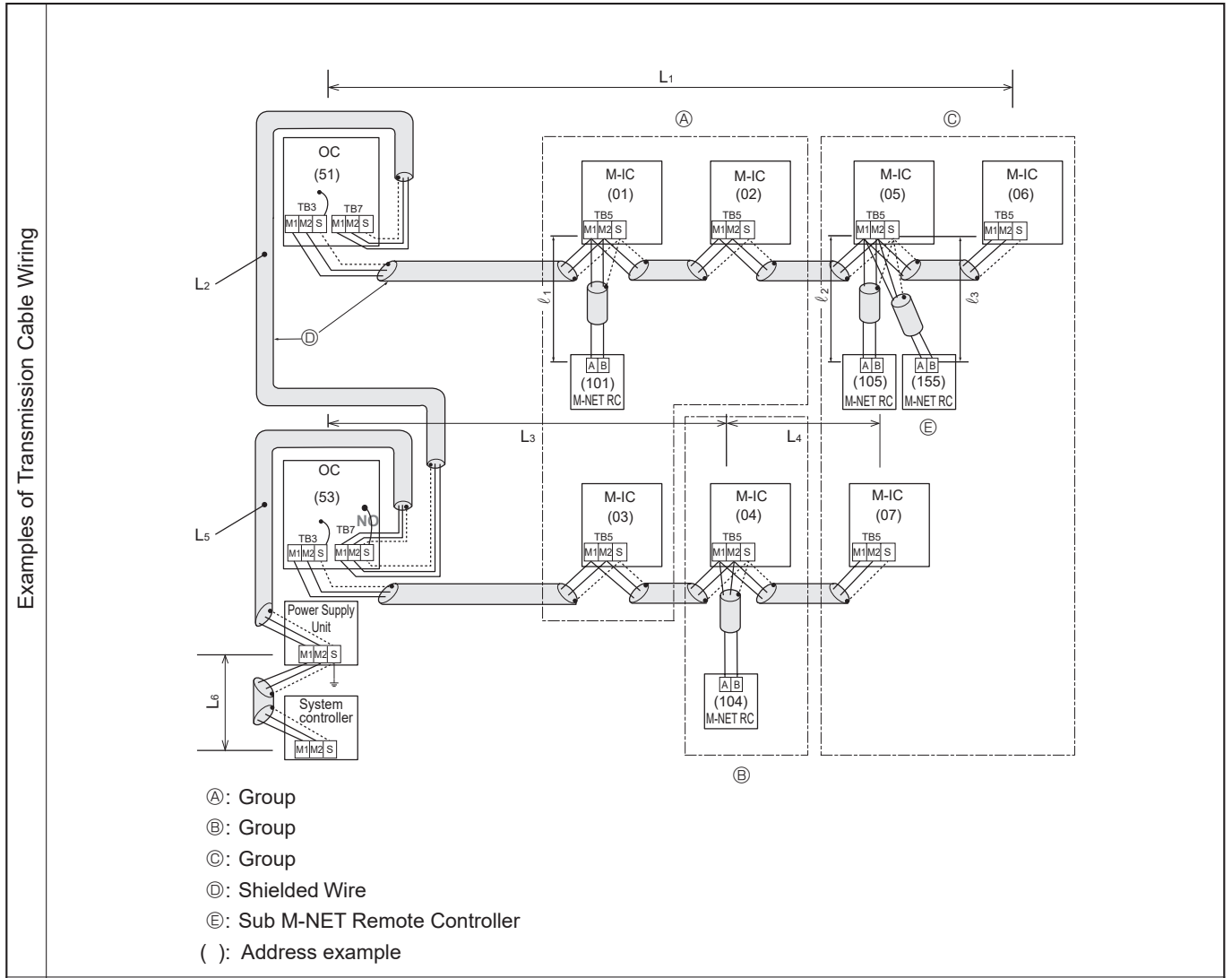

- Wiring Method Address Settings
- Always use shielded wire when making connections between the outdoor unit (OC) and the CITY MULTI series indoor unit (M-IC), as well for all OC-OC, and IC-IC wiring intervals.
 - Use feed wiring to connect terminals M1 and M2 and the ground terminal on the transmission cable terminal block (TB3) of each outdoor unit (OC) to terminals M1 and M2 on the terminal S on the transmission cable terminal block of the CITY MULTI series indoor unit (M-IC).
 - Connect terminals M1 and M2 on the transmission cable terminal block of the CITY MULTI series indoor unit (M-IC) that has the most recent address within the same group to the terminal block on the M-NET remote controller (M-NET RC).
 - Connect together terminals M1, M2 and terminal S on the terminal block for centralized control (TB7) for the outdoor unit (OC).
 - DO NOT change the jumper connector CN41 on outdoor multi controller circuit board.
 - The earth processing of S terminal for the centralized control terminal block (TB7) is unnecessary. Connect the terminal S on the power supply unit with the earth.
 - Set the address setting switch as follows.

Unit	Range	Setting Method
M-IC (Main)	01 to 50	Use the smallest address within the same group of CITY MULTI series indoor units.
M-IC (Sub)	01 to 50	Use an address, other than the M-IC (Main) in the same group of CITY MULTI series indoor units. This must be in sequence with the M-IC (Main).
Outdoor Unit	51 to 100	Use the smallest address of all the CITY MULTI series indoor units plus 50. The address automatically becomes "100" if it is set as "01-50".
Main M-NET Remote Controller	101 to 150	Set at an M-IC (Main) address within the same group plus 100.
Sub M-NET Remote Controller	151 to 200	Set at an M-IC (Main) address within the same group plus 150.
MA Remote Controller	—	Address setting is not necessary. (Main/sub setting is necessary.)

- The group setting operations among the multiple CITY MULTI series indoor units are done by the M-NET remote controller (M-NET RC) after the electrical power has been turned on.

• Name, Symbol, and the Maximum Units for Connection

Permissible Length

- Maximum line length via outdoor unit: $L_1+L_2+L_3+L_4$, $L_3+L_4+L_5+L_6$, $L_1+L_2+L_5+L_6$ [1640 ft [500 m] (AWG16 [1.25 mm²])
- Indoor/outdoor transmission line Maximum length: L_1 , L_3+L_4 , L_2+L_5 , L_6 [656 ft [200 m] (AWG16 [1.25 mm²])
- M-NET Remote controller cable length: R_1, R_2+R_3 [33 ft [10 m] (AWG20 to AWG16 [0.5 to 1.25 mm²])

If the length exceeds 33 ft [10 m], use an AWG16 [1.25 mm²] shielded wire. The section of the cable that exceeds 33 ft [10 m] must be included in the max length via outdoor units and max transmission cable length.

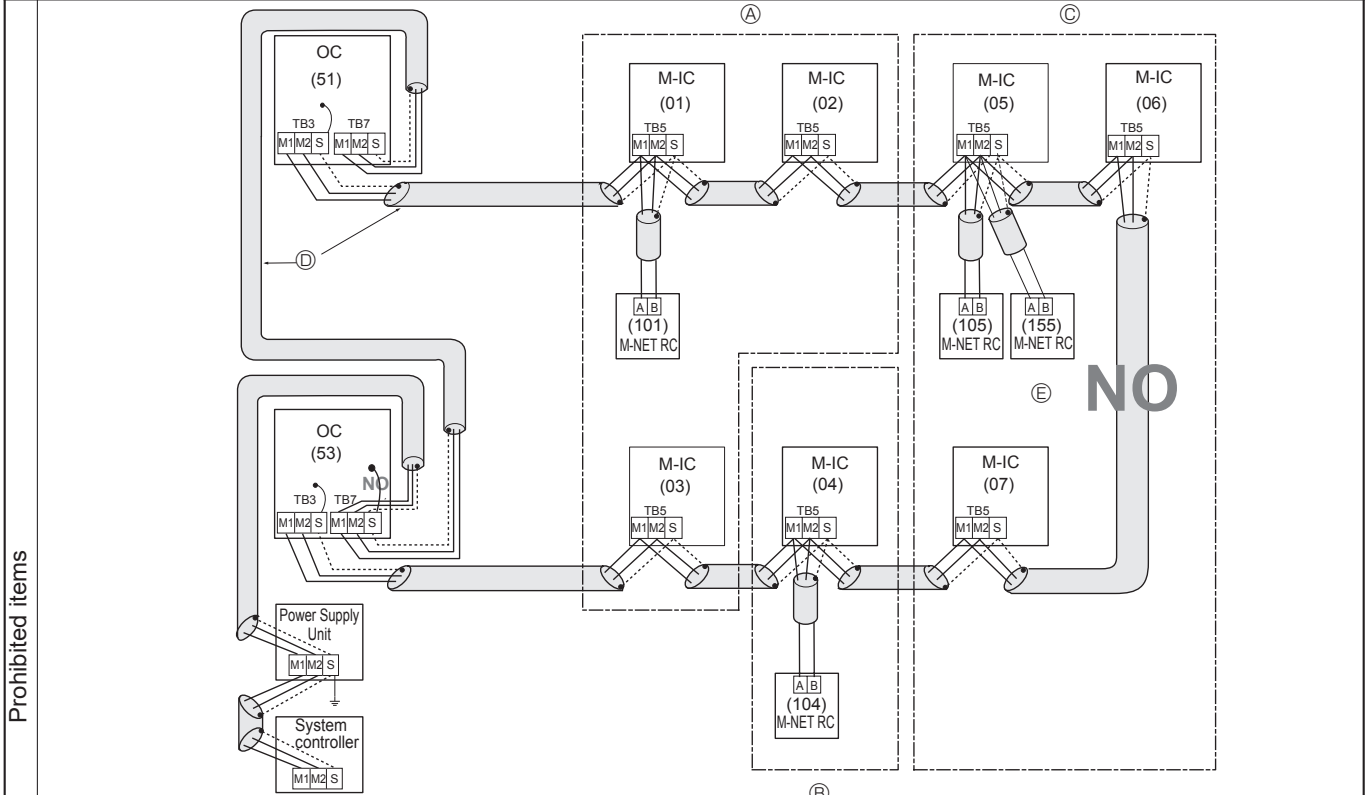

- (A) : Group
- (B) : Group
- (C) : Group
- (D) : Shielded Wire
- (E) : Sub M-NET Remote Controller
- () : Address example

- Never connect together the terminal blocks (TB5) for transmission wires for CITY MULTI series indoor unit (M-IC) that have been connected to different outdoor units (OC).
- Set all addresses to ensure that they are not overlapped.
- M-NET remote controller and MA remote controller cannot be connected with the CITY MULTI series indoor unit of the same group wiring together.

C. Example of a MA remote controller system (address setting is not necessary.)

NOTE: In the case of same group operation, need to set the address that is only main CITY MULTI series indoor unit.

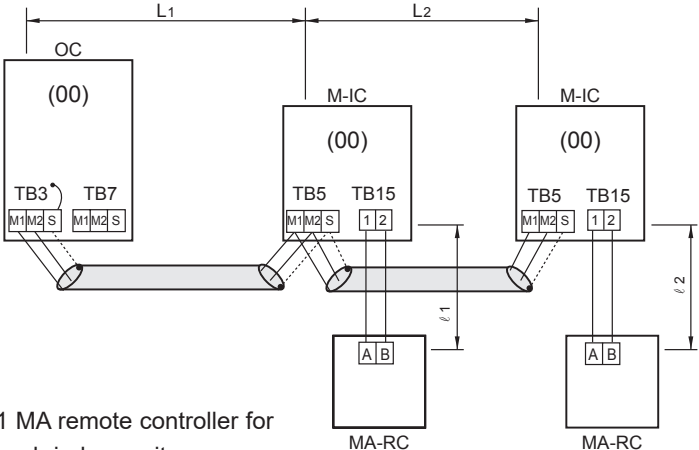
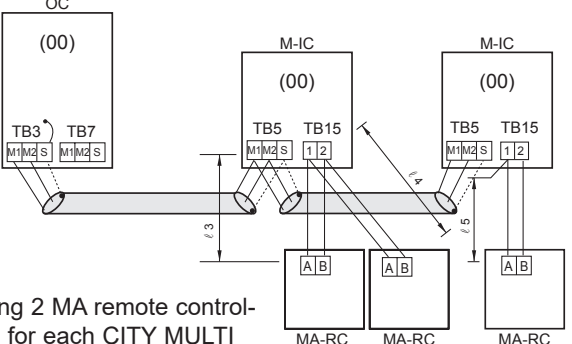
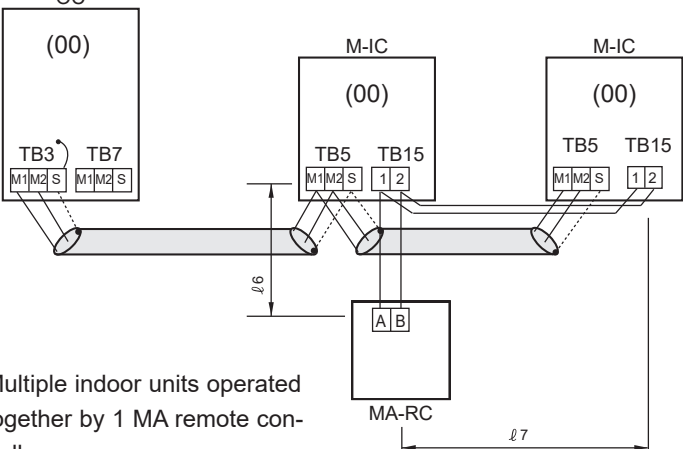
Example of wiring control cables	Wiring Method and Address Setting
<p>1. Standard operation</p>  <p>• 1 MA remote controller for each indoor unit</p>	<p>a. Use feed wiring to connect terminals M1 and M2 on transmission cable block (TB3) for the outdoor unit (OC) to terminals M1 and M2 on the transmission cable block (TB5) of each CITY MULTI series indoor unit (M-IC). Use non-polarized 2-core wire.</p> <p>b. Connect terminals 1 and 2 on transmission cable terminal block (TB15) for each CITY MULTI series indoor unit with the terminal block for the MA remote controller (MA-RC).</p>
<p>2. Operation using 2 remote controllers</p>  <p>• Using 2 MA remote controllers for each CITY MULTI series indoor unit</p>	<p>a. The same as above a</p> <p>b. The same as above b</p> <p>c. In the case of using 2 remote controllers, connect terminals 1 and 2 on transmission cable terminal block (TB15) for each indoor unit with the terminal block for 2 MA remote controllers.</p> <p>· Set either one of the controllers to "sub remote controller".</p> <p>Refer to the installation manual of MA remote controller.</p>
<p>3. Group operation</p>  <p>• Multiple indoor units operated together by 1 MA remote controller</p>	<p>a. The same as above a</p> <p>b. The same as above b</p> <p>c. In the case of group operation using MA remote controller (MA-RC), connect terminals 1 and 2 on transmission cable terminal block (TB15) of each CITY MULTI series indoor unit. Use non-polarized 2-core wire.</p> <p>d. In the case of same group operation, need to set the address that is only main CITY MULTI series indoor unit. Please set the smallest address within number 01–50 of the CITY MULTI series indoor unit with the most functions in the same group.</p>
<p>Combinations of 1 through 3 above are possible.</p>	

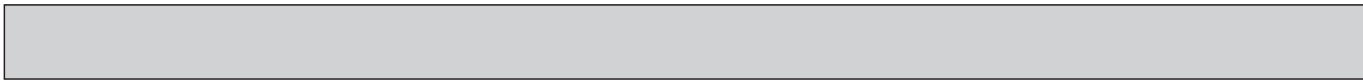

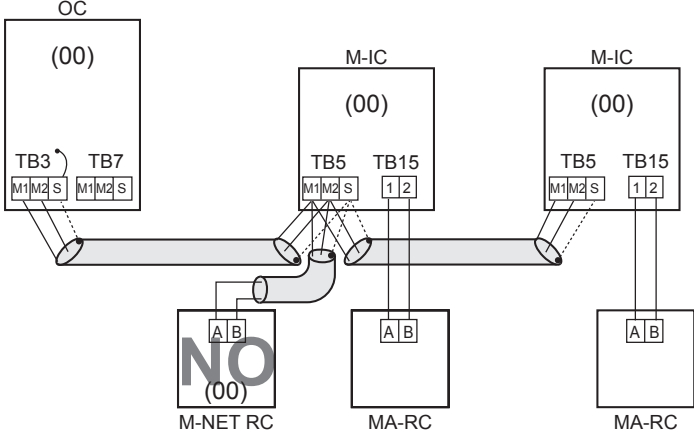
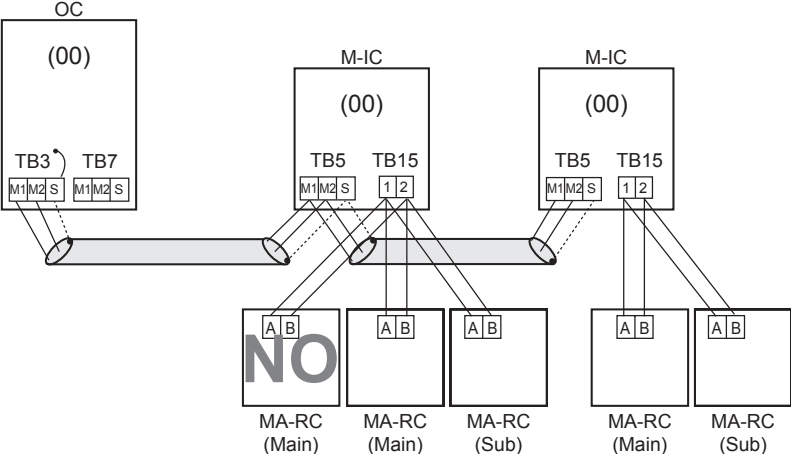
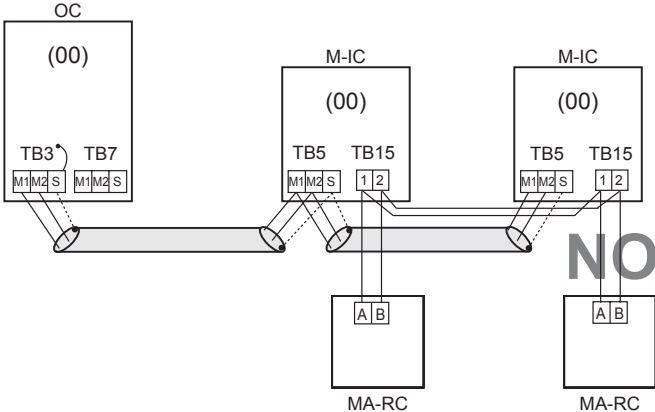
Permissible Lengths	Prohibited items
<p>Indoor/outdoor transmission line Maximum length: L1 + L2 [656 ft [200 m] (AWG 16 [1.25 mm²]) MA remote controller cable length: R1, R2 [656 ft [200 m] (AWG 22 to AWG 16 [0.3 to 1.25 mm²])</p>	<p>The MA remote controller and the M-NET remote controller cannot be used together with the CITY MULTI series indoor unit of the same group. M-NET remote controller cannot be connected without address setting.</p> 
<p>Indoor/outdoor transmission line Maximum length: L1 + L2 [656 ft [200 m] (AWG 16 [1.25 mm²]) MA remote controller cable length: R3 +R4, R5 [656 ft [200 m] (AWG 22 to AWG 16 [0.3 to 1.25 mm²])</p>	<p>3 MA remote controllers or more cannot be connected with the CITY MULTI series indoor unit of the same group.</p> 
<p>Indoor/outdoor transmission line Maximum length: L1 + L2 [656 ft [200 m] (AWG 16 [1.25 mm²]) MA remote controller cable length: R6 +R7 [656 ft [200 m] (AWG 22 to AWG 16 [0.3 to 1.25 mm²])</p>	<p>The second MA remote controller is connected with the terminal block (TB15) for the MA remote controller of the same CITY MULTI series indoor unit (M-IC) as the first MA remote control.</p> 

D. Example of a group operation with 2 or more outdoor units and an MA remote controller.
(Address settings are necessary.)

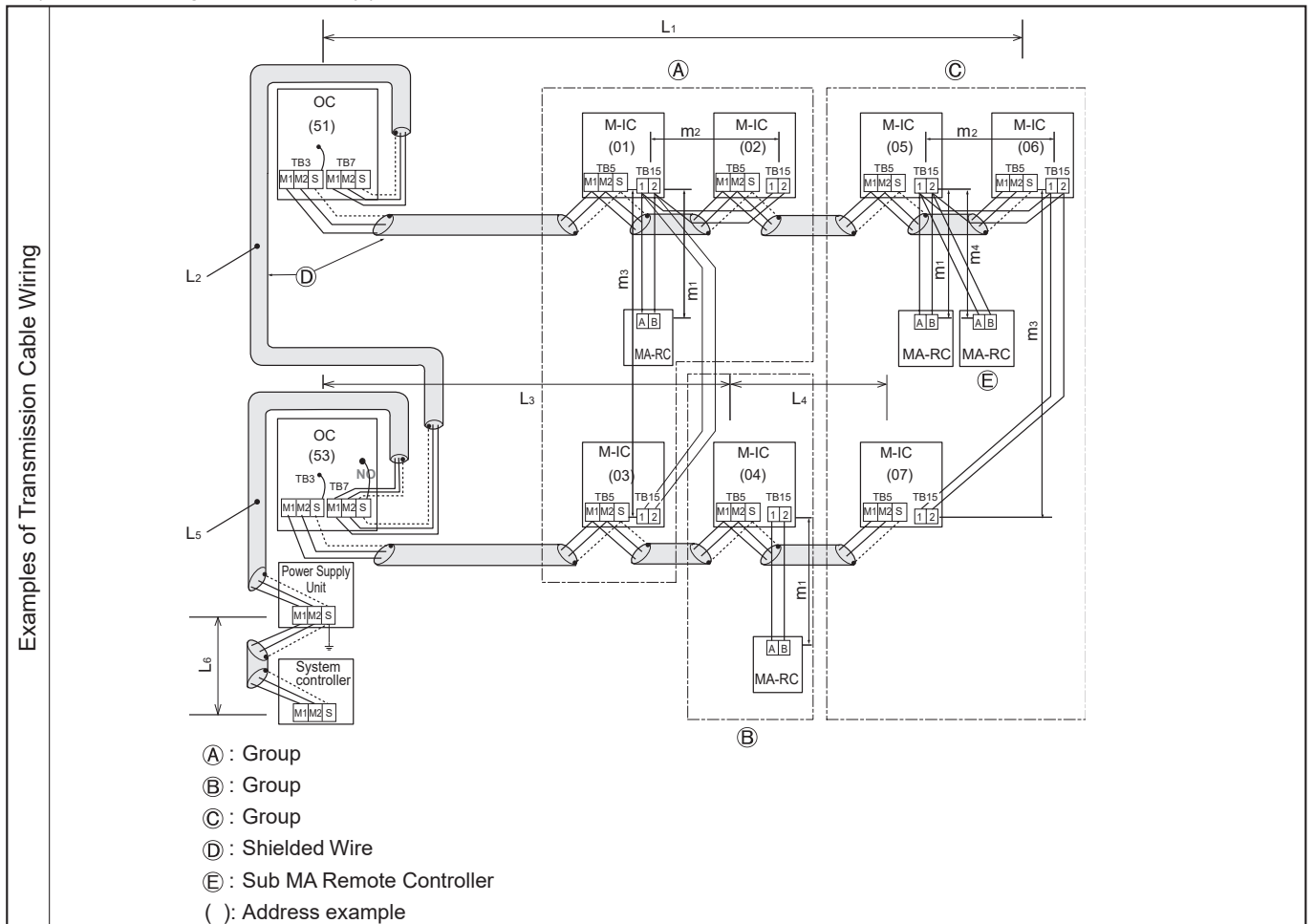

- Wiring Method Address Settings
- Always use shielded wire when making connections between the outdoor unit (OC) and the CITY MULTI series indoor unit (M-IC), as well for all OC-OC, and IC-IC wiring intervals.
 - Use feed wiring to connect terminals M1 and M2 and the ground terminal on the transmission cable terminal block (TB3) of each outdoor unit (OC) to terminals M1 and M2 on the terminal S on the transmission cable terminal block of the CITY MULTI series indoor unit (M-IC).
 - Connect terminals 1 and 2 on the terminal block for MA remote controller line (TB15) on the indoor unit (IC) to the terminal block on the MA remote controller (MA). (Nonpolarized two-wire).
 - Connect together terminals M1, M2 and terminal S on the terminal block for centralized control (TB7) for the outdoor unit (OC).
 - DO NOT change the jumper connector CN41 on outdoor multi controller circuit board.
 - The earth processing of S terminal for the centralized control terminal block (TB7) is unnecessary. Connect the terminal S on the power supply unit with the earth.
 - Set the address setting switch as follows.

Unit	Range	Setting Method
M-IC (Main)	01 to 50	Use the smallest address within the same group of indoor units.
M-IC (Sub)	01 to 50	Use an address, other than the M-IC (Main) in the same group of CITY MULTI series indoor units. This must be in sequence with the M-IC (Main).
Outdoor Unit	51 to 100	Use the smallest address of all the indoor units plus 50. The address automatically becomes "100" if it is set as "01-50".
Main M-NET Remote Controller	101 to 150	Set at an M-IC (Main) address within the same group plus 100.
Sub M-NET Remote Controller	151 to 200	Set at an M-IC (Main) address within the same group plus 150.
MA Remote Controller	—	Address setting is not necessary. (Main/sub setting is necessary.)

- The group setting operations among the multiple CITY MULTI series indoor unit is done by the M-NET remote controller (M-NET RC) after the electrical power has been turned on.

• Name, Symbol, and the Maximum Units for Connection

Permissible Length
 Maximum line length via outdoor unit (M-NET cable): $L_1+L_2+L_3+L_4$ and $L_1+L_2+L_6+L_7$ [1640 ft [500 m] (AWG 16 [1.25 mm²] or more)
 Indoor/outdoor transmission line Maximum length (M-NET cable): L_1 and L_3+L_4 and L_2+L_6 and L_7 [656 ft [200 m] (AWG 16 [1.25 mm²] or more)
 MA Remote controller cable length: m_1 and $m_1+m_2+m_3$ and $m_1+m_2+m_3+m_4$ [656 ft [200 m] (AWG 22 to AWG 16 [0.3 to 1.25 mm²])

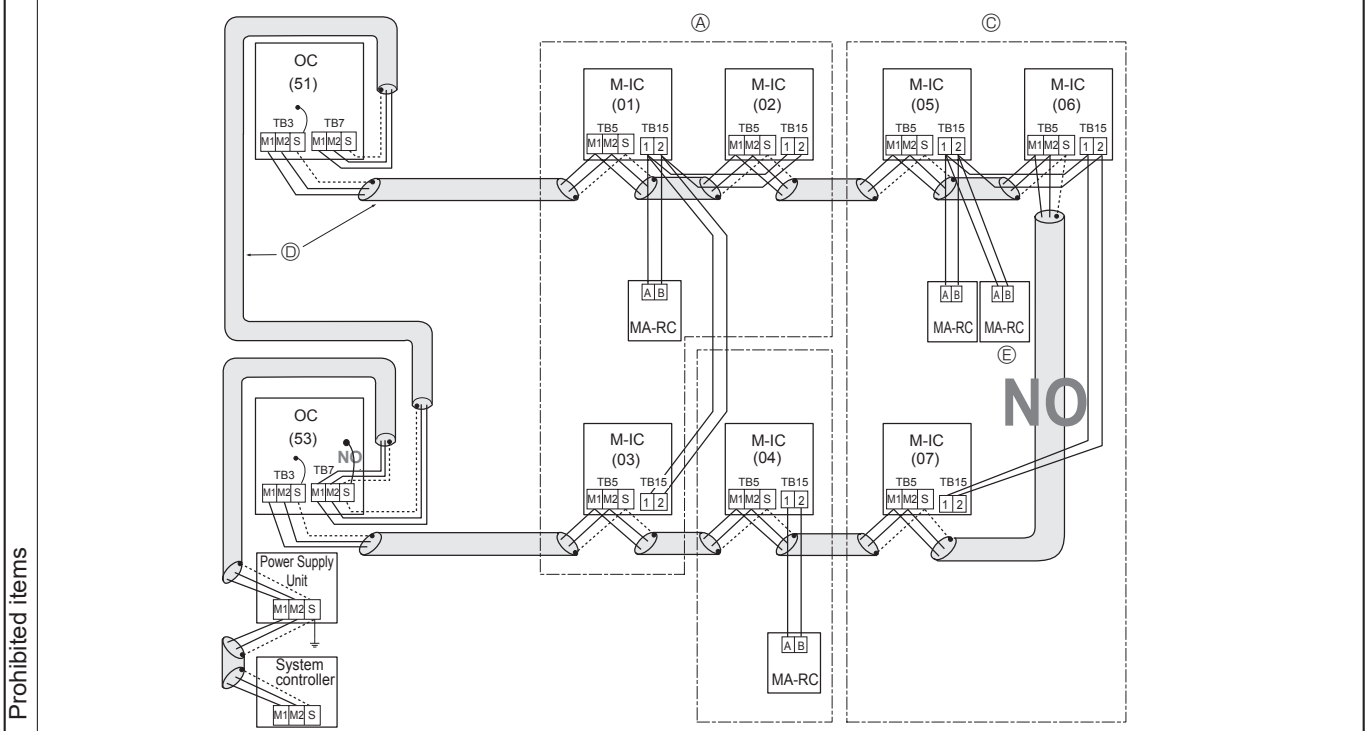

Prohibited items

- (A) : Group
- (B) : Group
- (C) : Group
- (D) : Shielded Wire
- (E) : Sub MA Remote Controller
- () : Address example

- Never connect together the terminal blocks (TB5) for transmission wires for CITY MULTI series indoor unit (M-IC) that have been connected to different outdoor units (OC).
- M-NET remote controller and MA remote controller cannot be connected with the CITY MULTI series indoor unit of the same group wiring together.

E. Example of a system using Branch Box and A-Control indoor unit

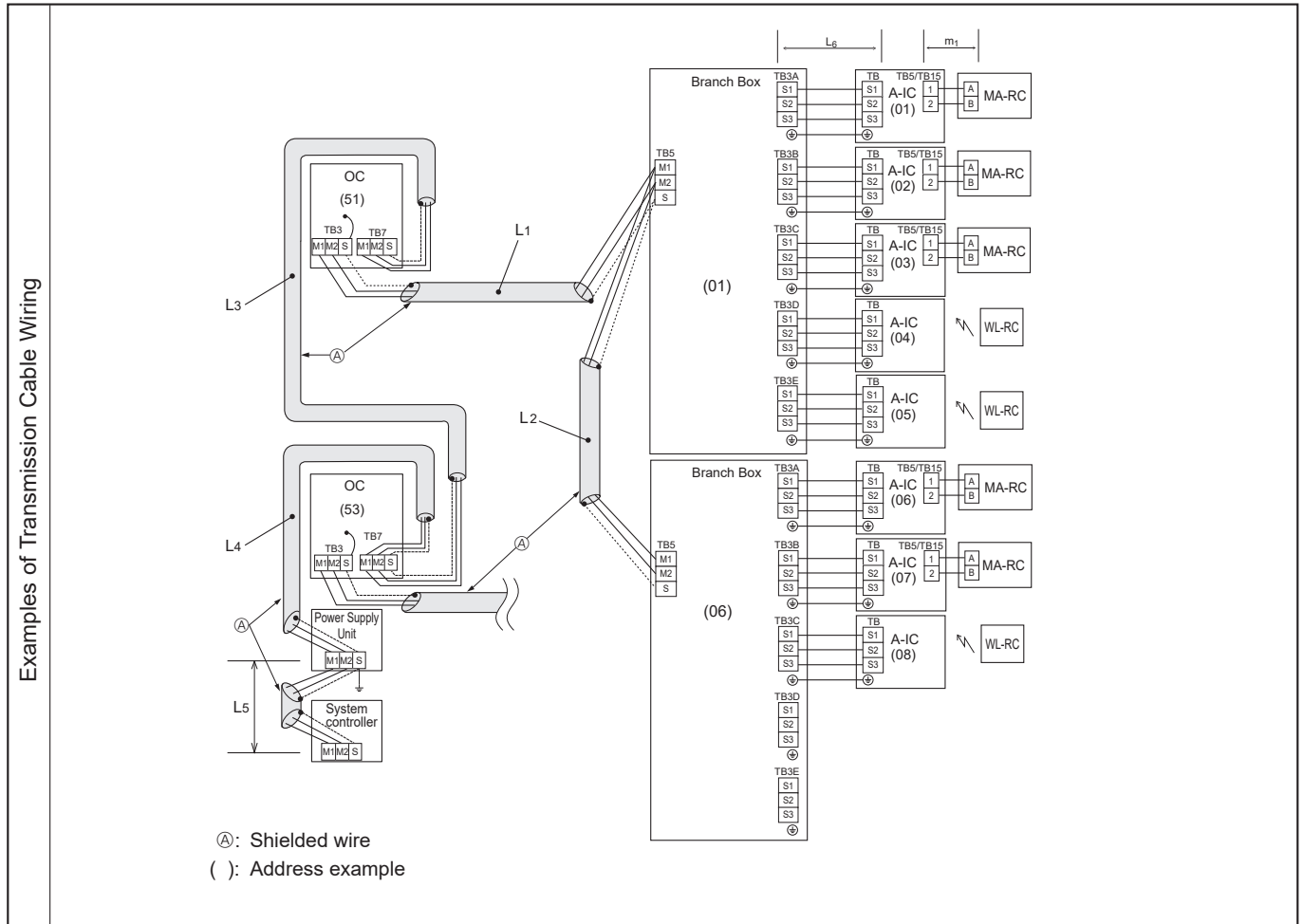

- Wiring Method Address Settings
- Always use shielded wire when making connections between the outdoor unit (OC) and the Branch Box, as well for all OC-OC wiring intervals.
 - Use feed wiring to connect terminals M1 and M2 and the ground terminal on the transmission cable terminal block (TB3) of each outdoor unit (OC) to terminals M1 and M2 on the terminal S on the transmission cable terminal block (TB5) of the Branch Box.
 - Connect terminals 1 and 2 on the transmission cable terminal block (TB5/TB15) of the A-control indoor unit (A-IC), to the terminal block on the MA remote controller (MA-RC).
 - Connect together terminals M1, M2 and terminal S on the terminal block for centralized control (TB7) for the outdoor unit (OC).
 - DO NOT change the jumper connector CN41 on outdoor multi controller circuit board.
 - The earth processing of S terminal for the centralized control terminal block (TB7) is unnecessary. Connect the terminal S on the power supply unit to the earth.
 - Set the address setting switch as follows.

Unit	Range	Setting Method
A-IC	01 to 50	According to the set address of connected Branch Box, set the A-IC addresses sequentially by SW1 on Branch Box. (For example, when setting the Branch Box address to 01, A-IC addresses set 02,03,04, and 05.)
Branch Box	01 to 50	Use a number within the range 1–50, but it should not make the highest address of connected A-IC exceed 50.
Outdoor Unit	51 to 100	Use the smallest address of all the Branch Box plus 50. The address automatically becomes “100” if it is set as “01–50”.
MA Remote Controller	–	Address setting is not necessary.

• Name, Symbol, and the Maximum Units for Connection

Permissible Length

Longest length via outdoor unit (M-NET cable): $L_1+L_2+L_3+L_4+L_5 \leq 1640$ ft [500 m] (AWG16 [1.25 mm²] or more)
 Branch box/outdoor transmission line Maximum length (M-NET cable): $L_1+L_2, L_3+L_4, L_5 \leq 656$ ft [200 m] (AWG16 [1.25 mm²] or more)
 Indoor/branch box transmission line Maximum length (A-Control cable): $L_6 \leq 82$ ft [25 m] (AWG14 [1.5 mm²])
 Remote controller cable length: $m_1 \leq 656$ ft [200 m] (AWG22 to AWG16 [0.3 to 1.25 mm²])

Constraint items

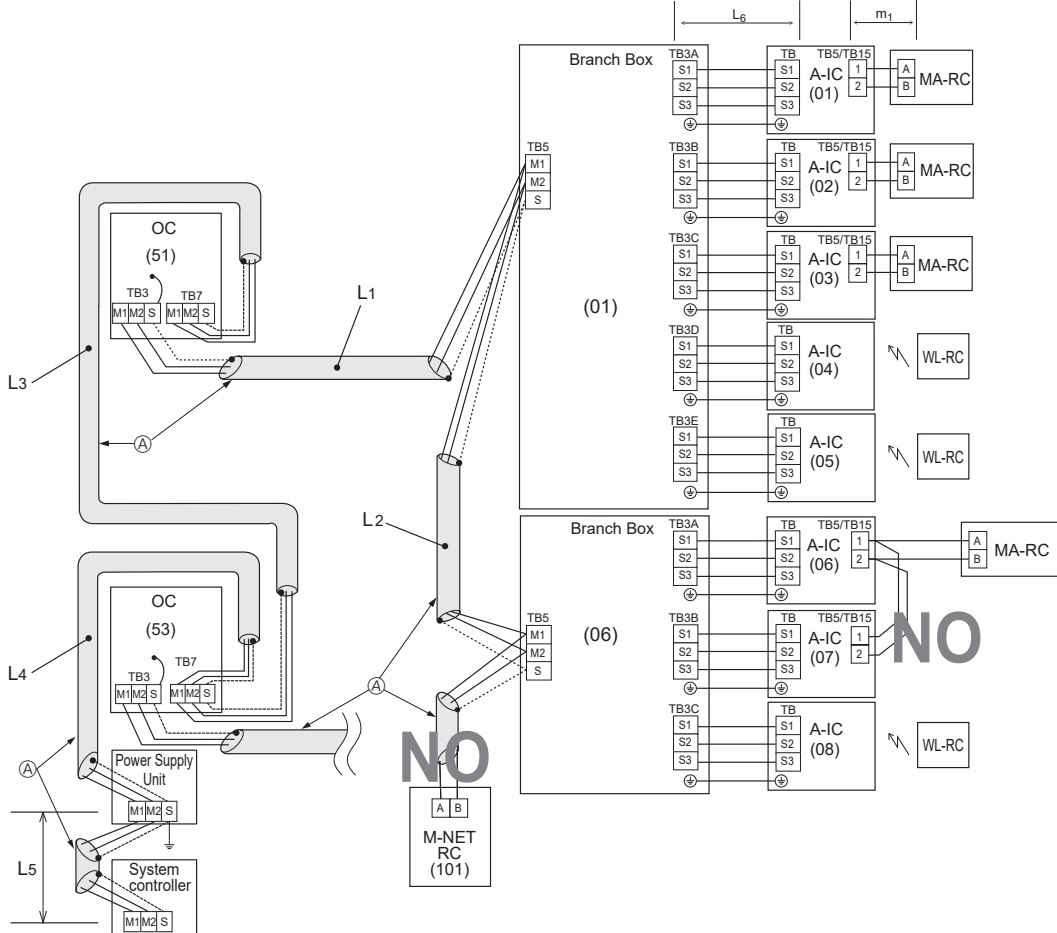

Ⓐ: Shielded wire
 (): Address example

- Plural indoor units cannot be operated by an MA single remote controller.
- Different refrigerant systems cannot be connected together.
- M-NET Remote controller cannot be connected to this system.

8-1. CHECKPOINTS FOR TEST RUN

8-1-1. Procedures before test run

- (1) Before a test run, make sure that the following work is completed.
 - Installation related:
Make sure that the panel of cassette type and electrical wiring are done.
Otherwise electrical functions like auto vane will not operate normally.
 - Piping related:
Perform leakage test of refrigerant and drain piping.
Make sure that all joints are perfectly insulated.
Check stop valves on both liquid and gas side for full open.
 - Electrical wiring related:
Check ground wire, transmission cable, remote controller cable, and power supply cable for secure connection.
Make sure that all switch settings of address or adjustments for special specification systems are correctly settled.
- (2) Safety check:
With the insulation tester of 500 V, inspect the insulation resistance.
Do not touch the transmission cable and remote controller cable with the tester.
The resistance should be over 1.0 M Ω . Do not proceed inspection if the resistance is less than 1.0 M Ω .
Inspect between the outdoor unit power supply terminal block and ground first, metallic parts like refrigerant pipes or the electrical box next, then inspect all electrical wiring of outdoor unit, indoor unit, and all linked equipment.
- (3) Before operation:
 - a) Turn the power supply switch of the outdoor unit to on for compressor protection. For a test run, wait at least 12 hours from this point.
 - b) Register control systems into remote controller(s). Never touch the ON/OFF switch of the remote controller(s). Refer to "7-2. Special Function Operation and Settings for M-NET Remote Controller" as for settings. In MA remote controller(s), this registration is unnecessary.
- (4) More than 12 hours later from power supply to the outdoor unit, turn all power switch to on for the test run. Perform test run according to the "Operation procedure" table of the bottom of this page. While test running, make test run reports.

8-1-1-1. Test run for M-NET Remote controller

For the detailed procedure, refer to the remote controller's manuals.

8-1-1-2. Test run for wired remote controller <PAR-4xMAA ("x" represents 0 or later)>

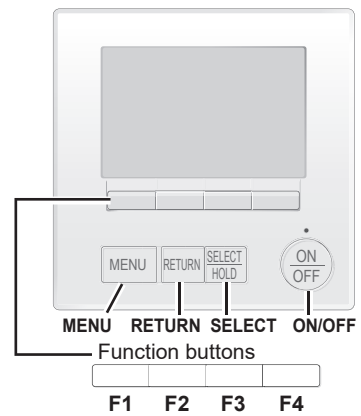

1 Select "Service" from the Main menu, and press the [SELECT] button.

Select "Test run" with the **F1** or **F2** button, and press the [SELECT] button.

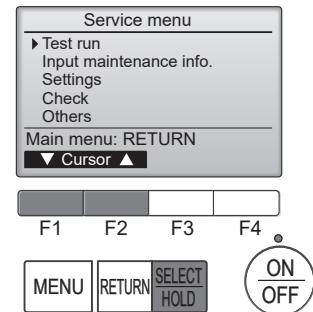

2 Select "Test run" with the **F1** or **F2** button, and press the [SELECT] button.

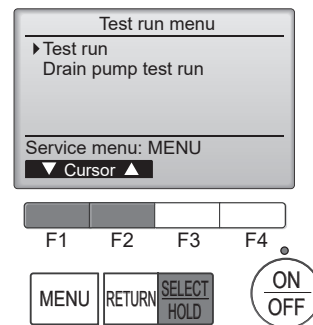

Test run operation

Press the **F1** button to go through the operation modes in the order of "Cool and Heat".

Cool mode: Check the cold air blows out.
Heat mode: Check the heat blows out.

Check the operation of the outdoor unit's fan.

Press the [SELECT] button and open the Vane setting screen.

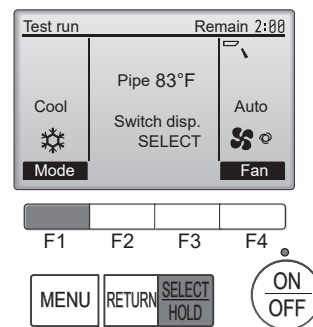

Auto vane check

Check the auto vane with the **F1** **F2** buttons.

Press the [RETURN] button to return to "Test run operation".

Press the [ON/OFF] button.

When the test run is completed, the "Test run menu" screen will appear. The test run will automatically stop after 2 hours.

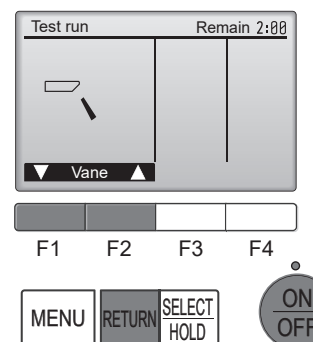

8-1-2. Countermeasures For Error During Test Run

If a problem occurs during test run, a code number will appear on the remote controller (or LED on the outdoor unit), and the air conditioning system will automatically cease operating.

Determine the nature of the abnormality and apply corrective measures.

Check code (2 digits)	Check code (4 digits)	Trouble	Detected Unit			Remarks
			Indoor	Outdoor	Remote Controller	
Ed	0403	Serial communication error		○		Outdoor unit Multi controller board–Power board communication trouble
U2	1102	Compressor temperature trouble		○		Check delay code 1202
UE	1302	High pressure trouble		○		Check delay code 1402
U7	1500	Superheat due to low discharge temperature trouble		○		Check delay code 1600
U2	1501	Refrigerant shortage trouble		○		Check delay code 1601
		Closed valve in cooling mode		○		Check delay code 1501
P6	1503	Freeze protection of Branch box or Indoor unit	○			
EF	1508	4-way valve trouble in heating mode		○		Check delay code 1608
L6	2135	Circulation water freeze protection	○			
PA	2500	Water leakage	○			
P5	2502	Drain overflow protection	○			
P4	2503	Drain sensor abnormality	○			
-	3121	Out-of-range outside air temperature		○		
UF	4100	Compressor current interruption (Locked compressor)		○		Check delay code 4350
Pb	4114	Fan trouble (Indoor)	○			
UP	4210	Compressor overcurrent interruption		○		
U9	4220	Voltage shortage/overvoltage/PAM error/L1open phase/power synchronization signal error		○		Check delay code 4320
U5	4230	Heat sink temperature trouble		○		Check delay code 4330
U6	4250	Power module Trouble or Overcurrent trouble		○		Check delay code 4350
U8	4400	Fan trouble (Outdoor)		○		Check delay code 4500
U3	5101	Air inlet thermistor (TH21) open/short	○			
		Compressor temperature thermistor (TH4) open/short		○		Check delay code 1202
U4	5102	Liquid pipe temperature thermistor (TH22) open/short	○			
		Suction pipe temperature thermistor (TH6) open/short		○		Check delay code 1211
U4	5103	Gas pipe temperature thermistor (TH23) open/short	○			
U4	5105	Outdoor liquid pipe temperature thermistor (TH3) open/short		○		Check delay code 1205
U4	5106	Ambient temperature thermistor (TH7) open/short		○		Check delay code 1221
U4	5109	HIC pipe temperature thermistor (TH2) open/short		○		Check delay code 1222
U4	5110	Heat sink temperature thermistor (TH8) open/short		○		Check delay code 1214
F5	5201	High pressure sensor (63HS) trouble		○		Check delay code 1402
F3	5202	Low pressure sensor (63LS) trouble		○		Check delay code 1400
UH	5300	Primary current error		○		Check delay code 4310
P4	5701	Contact failure of drain float switch	○			
A0	6600	Duplex address error	○	○	○	Only M-NET Remote controller is detected.
A2	6602	Transmission processor hardware error	○	○	○	Only M-NET Remote controller is detected.
A3	6603	Transmission bus BUSY error	○	○	○	Only M-NET Remote controller is detected.
A6	6606	Signal communication error with transmission processor	○	○	○	Only M-NET Remote controller is detected.
A7	6607	No ACK error	○	○	○	Only M-NET Remote controller is detected.
A8	6608	No response frame error	○	○	○	Only M-NET Remote controller is detected.
E0/E4	6831	MA communication receive error (no receive signal)	○		○	Only MA Remote controller is detected.
E3/E5	6832	MA communication send error	○		○	Only MA Remote controller is detected.
E3/E5	6833	MA communication send error	○		○	Only MA Remote controller is detected.
E0/E4	6834	MA communication receive error	○		○	Only MA Remote controller is detected.
EF	7100	Total capacity error		○		
EF	7101	Capacity code error	○	○		
EF	7102	Connecting unit number error		○		
EF	7105	Address setting error		○		
EF	7130	Incompatible unit combination		○		

NOTES:

- When the outdoor unit detects No ACK error/No response error, an object indoor unit is treated as a stop, and not assumed to be abnormal.
- The check codes displayed on the units may be different between the error source and others. In that case, please refer to the check code of error source by displayed attribute and address.
- Refer to the service manual of indoor unit or remote controller for the detail of error detected in indoor unit or remote controller.

- Self-diagnosis function

The indoor and outdoor units can be diagnosed automatically using the self-diagnosis switch (SW1) and LED indication (LED1, LED2) found on the outdoor multi controller circuit board.
LED indication : Set all contacts of SW1 to OFF.

- During normal operation

The LED indicates the drive state of outdoor unit.

Bit	1	2	3	4	5	6	7	8
Indication	Compressor operated	52C	21S4	SV1	SV2	—	—	Always lit

[Example]

When the compressor and SV1 are on during cooling operation.

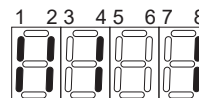

8-1-3. SELF-DIAGNOSIS ACTION BY FLOWCHART

Check code	Serial communication error
0403 (Ed)	

Abnormal points and detection methods	Causes and checkpoints
If serial communication between the outdoor multi controller circuit board and outdoor power circuit board is defective.	<ul style="list-style-type: none"> ① Wire breakage or contact failure of connector CN2 or CN4 ② Malfunction of communication circuit to power circuit board on outdoor multi controller circuit board ③ Malfunction of communication circuit on outdoor power circuit board

●Diagnosis of defects

Make sure to turn the power OFF before connecting/disconnecting any connectors, or replacing boards.

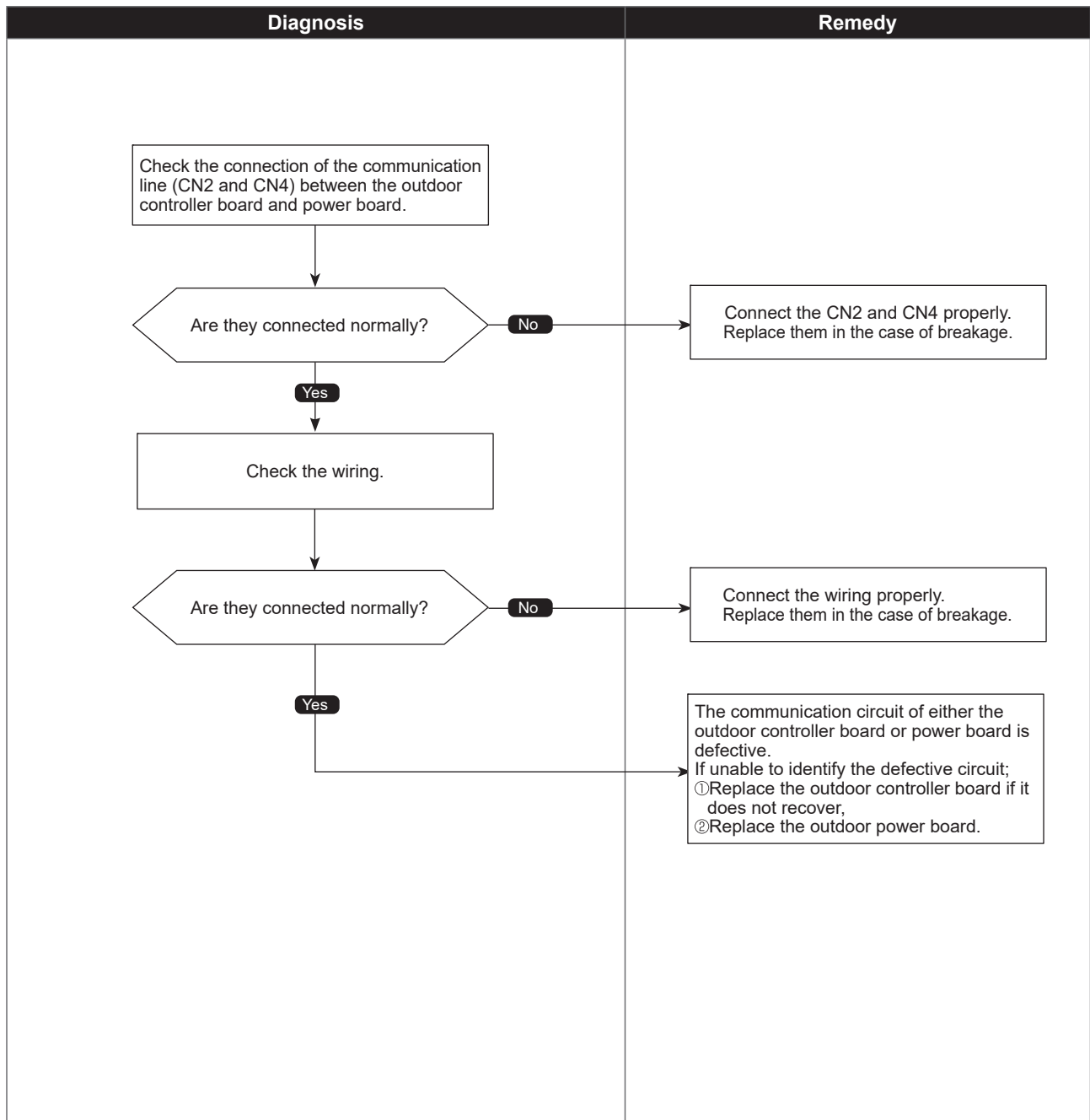

Compressor temperature trouble

Abnormal points and detection methods	Causes and checkpoints
<p>(1) If the TH4 temperature becomes conditions as follows:</p> <ul style="list-style-type: none"> ●exceeds 230°F [110°C] continuously for 5 minutes ●exceeds 257°F[125°C] <p>(2) If a pressure detected by the high pressure sensor and converted to saturation temperature exceeds 104°F [40°C] during defrosting, and TH4 exceeds 230°F [110°C].</p> <p>TH4: Thermistor <Compressor> LEV: Linear expansion valve</p>	<ul style="list-style-type: none"> ① Malfunction of stop valve ② Over-heated compressor operation caused by shortage of refrigerant ③ Defective thermistor ④ Defective outdoor controller board ⑤ LEV performance failure ⑥ Defective indoor controller board ⑦ Clogged refrigerant system caused by foreign object ⑧ Refrigerant shortage while in heating operation (Refrigerant liquid accumulation in compressor while indoor unit is OFF/thermo-OFF.)

●Diagnosis of defects

Make sure to turn the power OFF before connecting/disconnecting any connectors, or replacing boards.

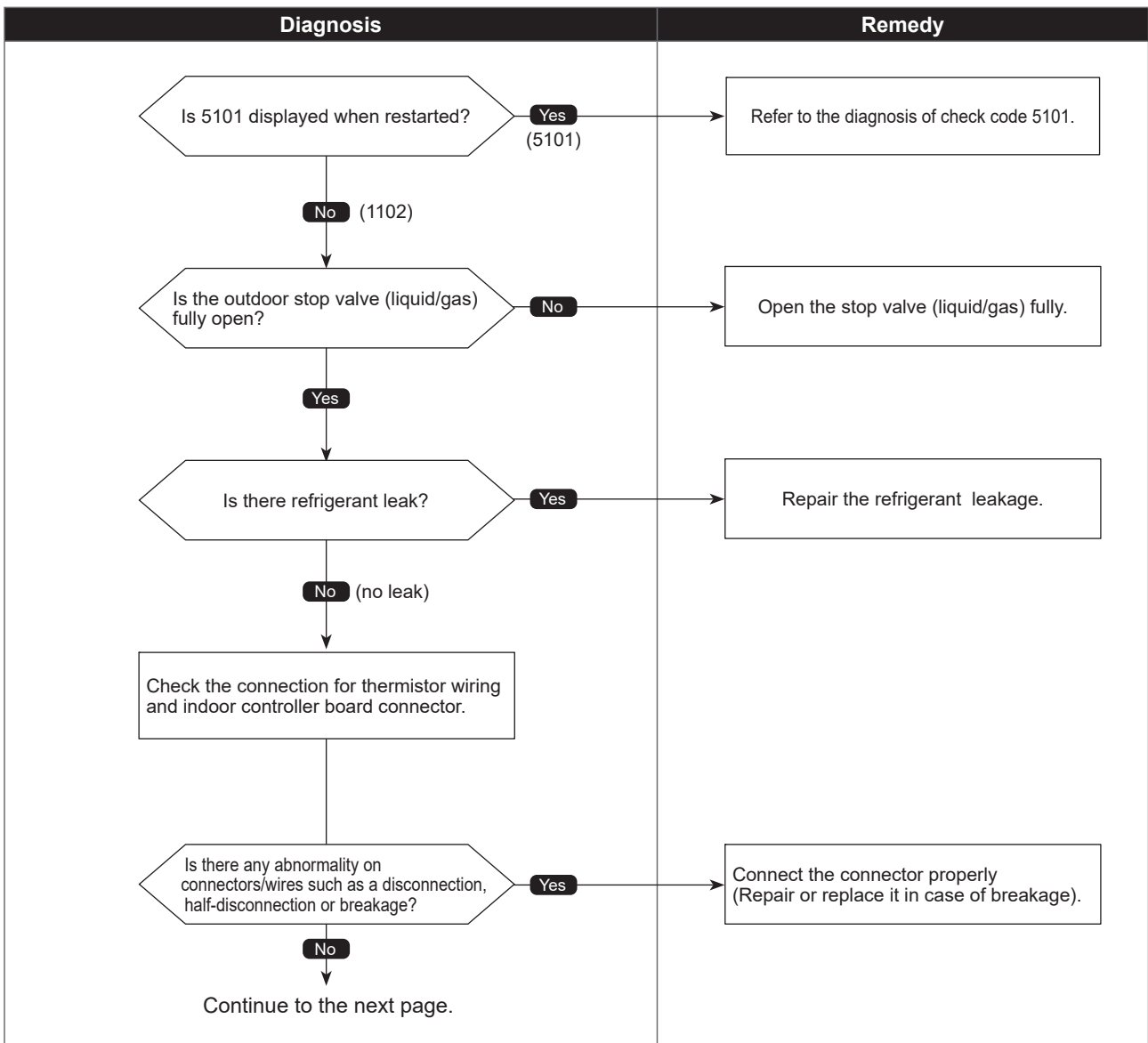

Compressor temperature trouble

●Diagnosis of defects

Make sure to turn the power OFF before connecting/disconnecting any connectors, or replacing boards.

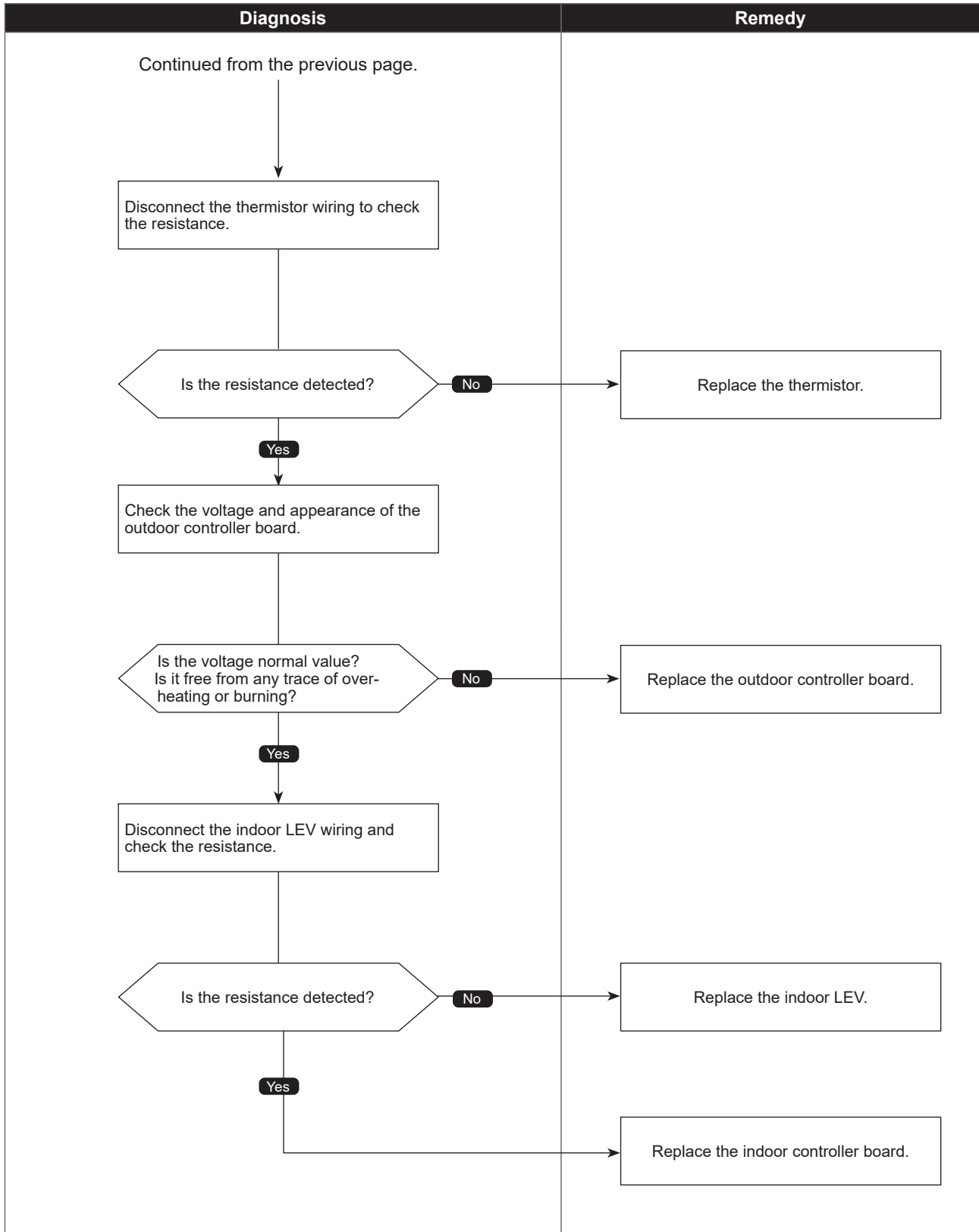

Abnormal points and detection methods	Causes and checkpoints
<p>(1) High pressure abnormality (63H operation) If 63H operates(*) during compressor operation. (*602 PSIG [4.15 MPaG])</p> <p>(2) High pressure abnormality (63HS detected) 1. If a pressure detected by 63HS is 625 PSIG [4.31 MPaG] or more during compressor operation. 2. If a pressure detected by 63HS is 600 PSIG [4.14 MpaG] or more for 3 minutes during compressor operation.</p> <p>63H : High pressure switch 63HS: High pressure sensor LEV : Linear expansion valve SV1 : Solenoid valve TH7 : Thermistor <Ambient></p>	<p>① Defective operation of stop valve (not fully open) ② Clogged or broken pipe ③ Malfunction or locked outdoor fan motor ④ Short-cycle of outdoor unit ⑤ Dirt of outdoor heat exchanger ⑥ Remote controller transmitting error caused by noise interference ⑦ Contact failure of the outdoor controller board connector ⑧ Defective outdoor controller board ⑨ Short-cycle of indoor unit ⑩ Decreased airflow, clogged filter, or dirt on indoor unit. ⑪ Malfunction or locked indoor fan motor ⑫ Decreased airflow caused by defective inspection of outdoor temperature thermistor (It detects lower temperature than actual temperature.) ⑬ Indoor LEV performance failure ⑭ Malfunction of fan driving circuit ⑮ SV1 performance failure ⑯ Defective high pressure sensor ⑰ Defective high pressure sensor input circuit on outdoor controller board</p>

●Diagnosis of defects

Make sure to turn the power OFF before connecting/disconnecting any connectors, or replacing boards.

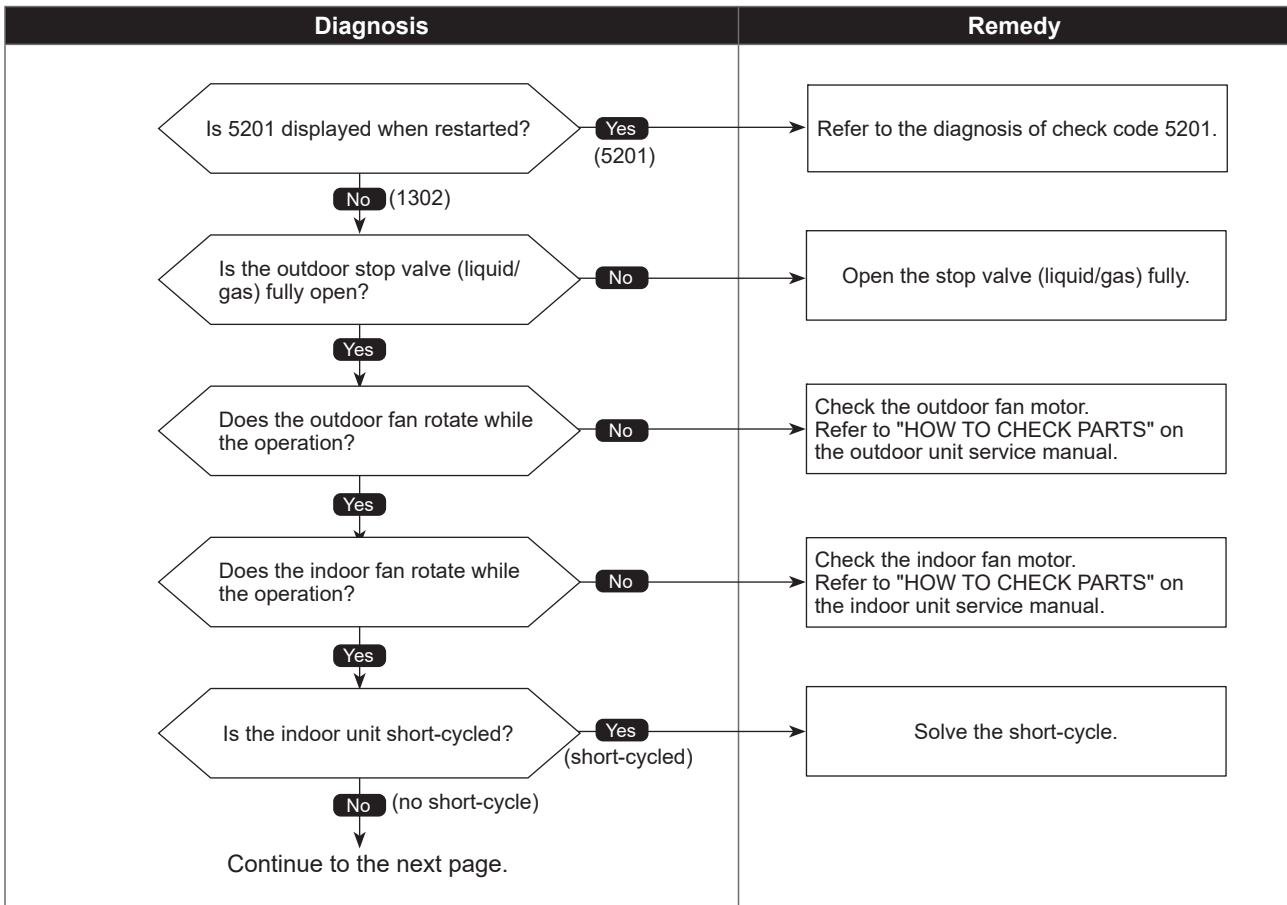

High pressure trouble

●Diagnosis of defects

Make sure to turn the power OFF before connecting/disconnecting any connectors, or replacing boards.

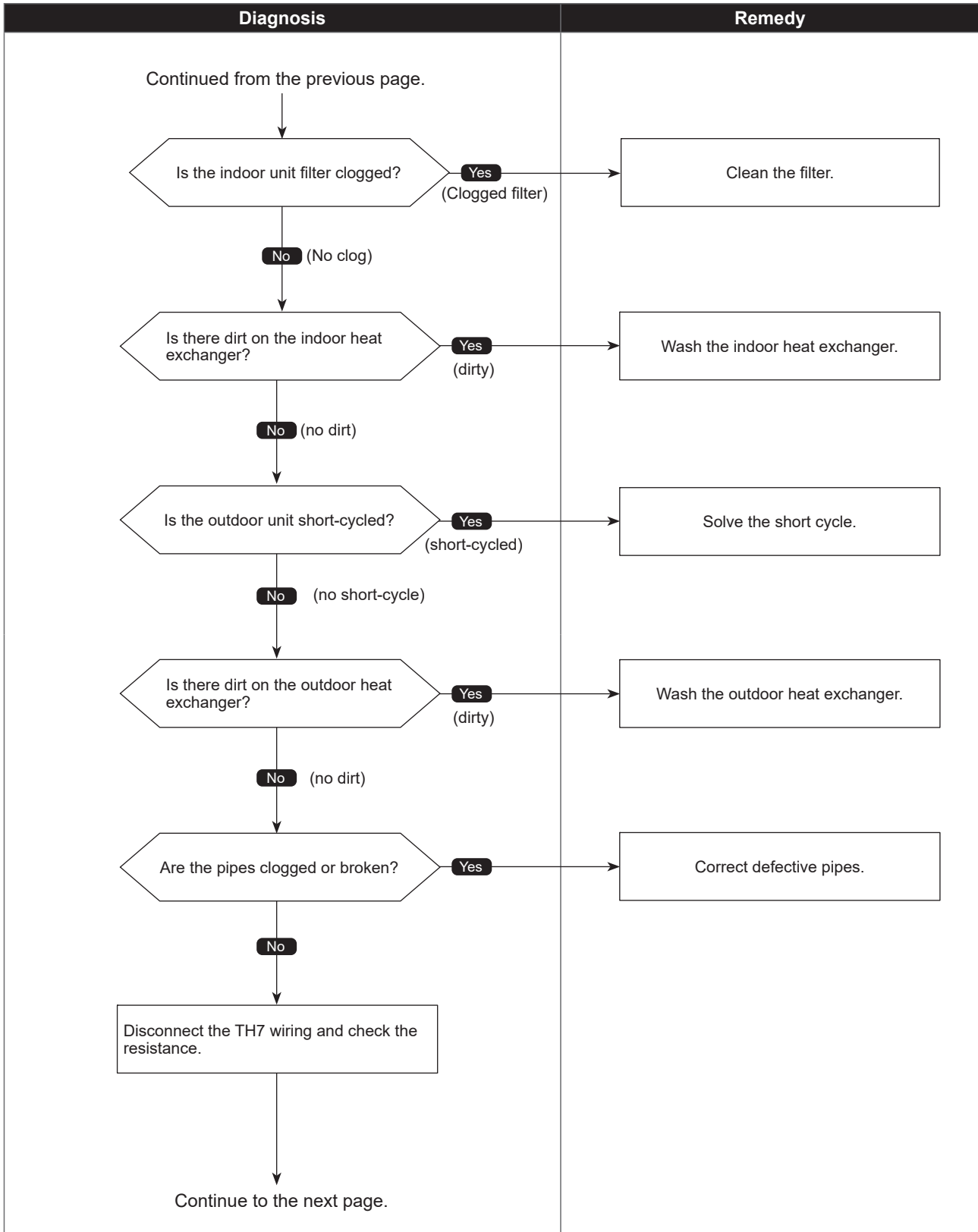

●Diagnosis of defects

Make sure to turn the power OFF before connecting/disconnecting any connectors, or replacing boards.

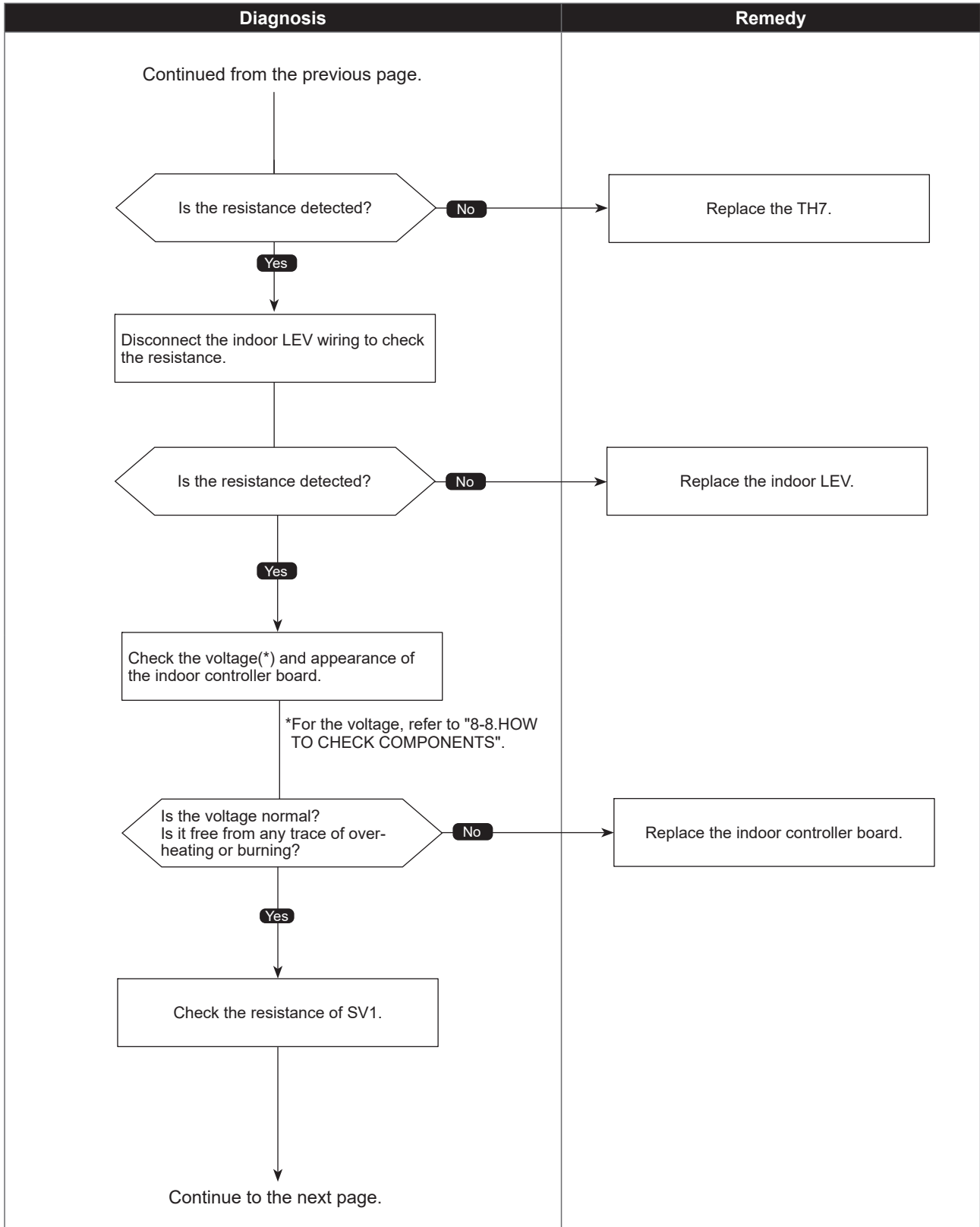

●Diagnosis of defects

Make sure to turn the power OFF before connecting/disconnecting any connectors, or replacing boards.

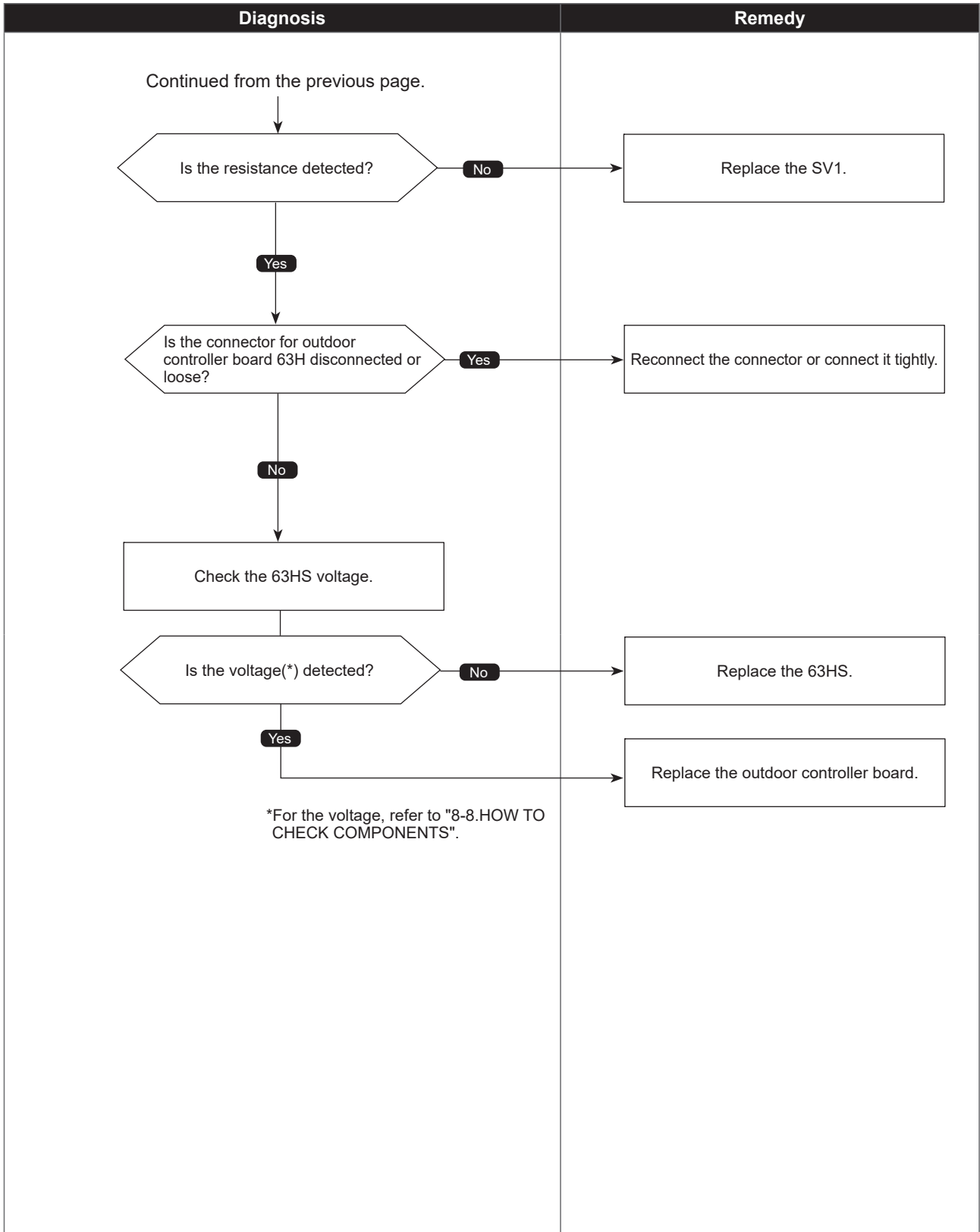

Superheat due to low discharge temperature trouble

Abnormal points and detection methods	Causes and checkpoints
<p>If the discharge superheat is continuously detected -27°F [-15°C](*) or less for 5 minutes even though the indoor LEV has minimum open pulse after the compressor starts operating for 10 minutes.</p> <p>LEV : Linear expansion valve TH4 : Thermistor <Compressor> 63HS: High pressure sensor</p> <p>*At this temperature, conditions for the abnormality detection will not be satisfied if no abnormality is detected on either TH4 or 63HS.</p>	<ul style="list-style-type: none"> ① Disconnection or loose connection of TH4 ② Defective holder of TH4 ③ Disconnection of LEV coil ④ Disconnection of LEV connector ⑤ LEV performance failure

●Diagnosis of defects

Make sure to turn the power OFF before connecting/disconnecting any connectors, or replacing boards.

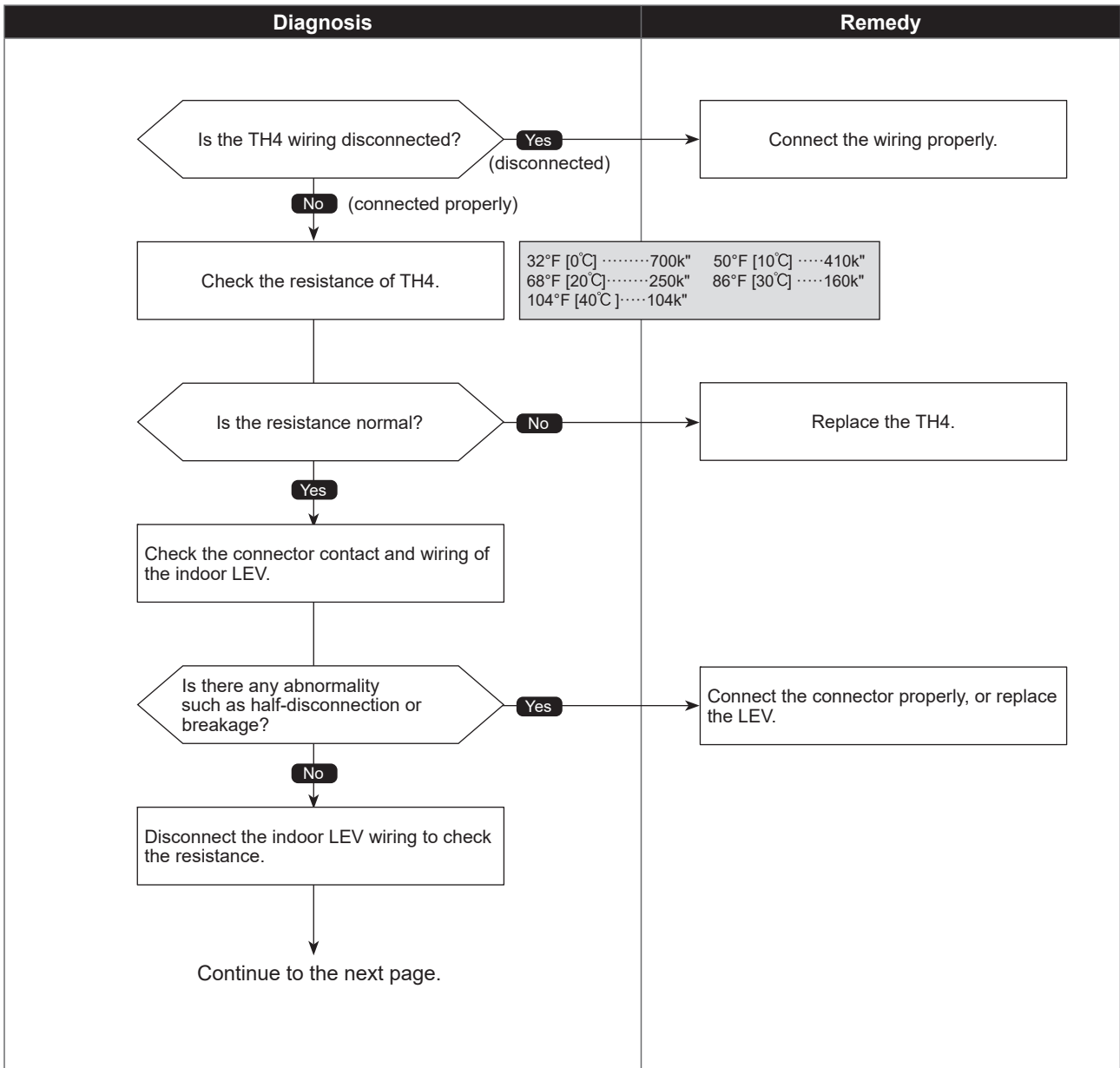

●Diagnosis of defects

Make sure to turn the power OFF before connecting/disconnecting any connectors, or replacing boards.

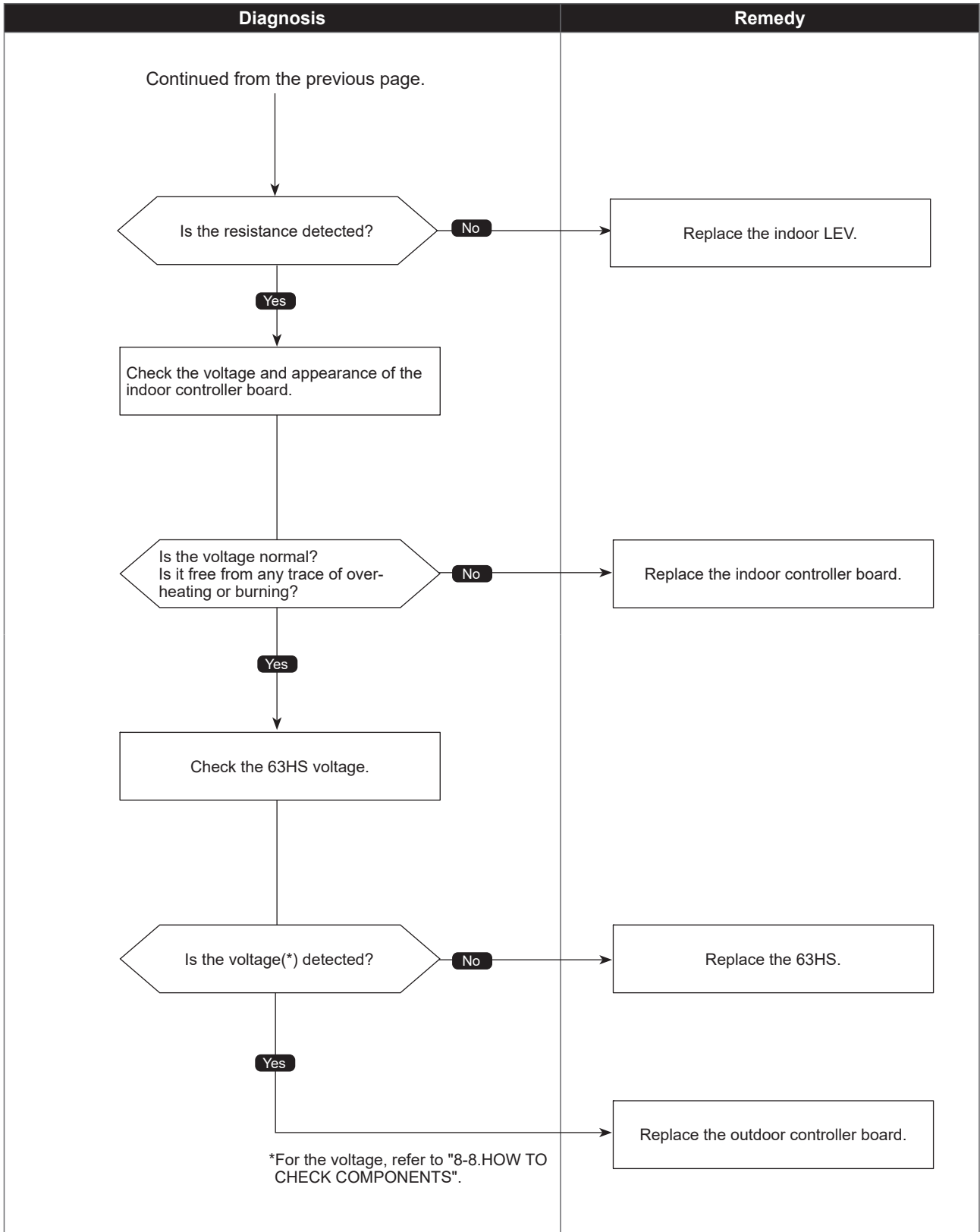

Refrigerant shortage trouble

Abnormal points and detection methods	Causes and checkpoints
<p>(1) When all of the following conditions have been satisfied for 15 consecutive minutes:</p> <ol style="list-style-type: none"> The compressor is operating in HEAT mode. Discharge super heat is 176°F [80°C] or more. Difference between TH7 and the TH3 applies to the formula of (TH7-TH3 < 9°F [5°C]). The saturation temperature converted from a high pressure sensor detects below 95°F [35°C]. <p>(2) When all of the following conditions have been satisfied:</p> <ol style="list-style-type: none"> The compressor is in operation. When cooling, discharge superheat is 144°F [80°C] or more, and the saturation temperature converted from a high pressure sensor is over -40°F [-40°C]. When heating, discharge superheat is 162°F [90°C] or more. 	<ol style="list-style-type: none"> Defective operation of stop valve (not fully open) Defective thermistor Defective outdoor controller board Indoor LEV performance failure Gas leakage or shortage Defective 63HS <p>TH3 : Thermistor <Outdoor liquid pipe> TH7 : Thermistor <Ambient> LEV : Linear expansion valve 63HS: High pressure sensor</p>

●Diagnosis of defects

Make sure to turn the power OFF before connecting/disconnecting any connectors, or replacing boards.

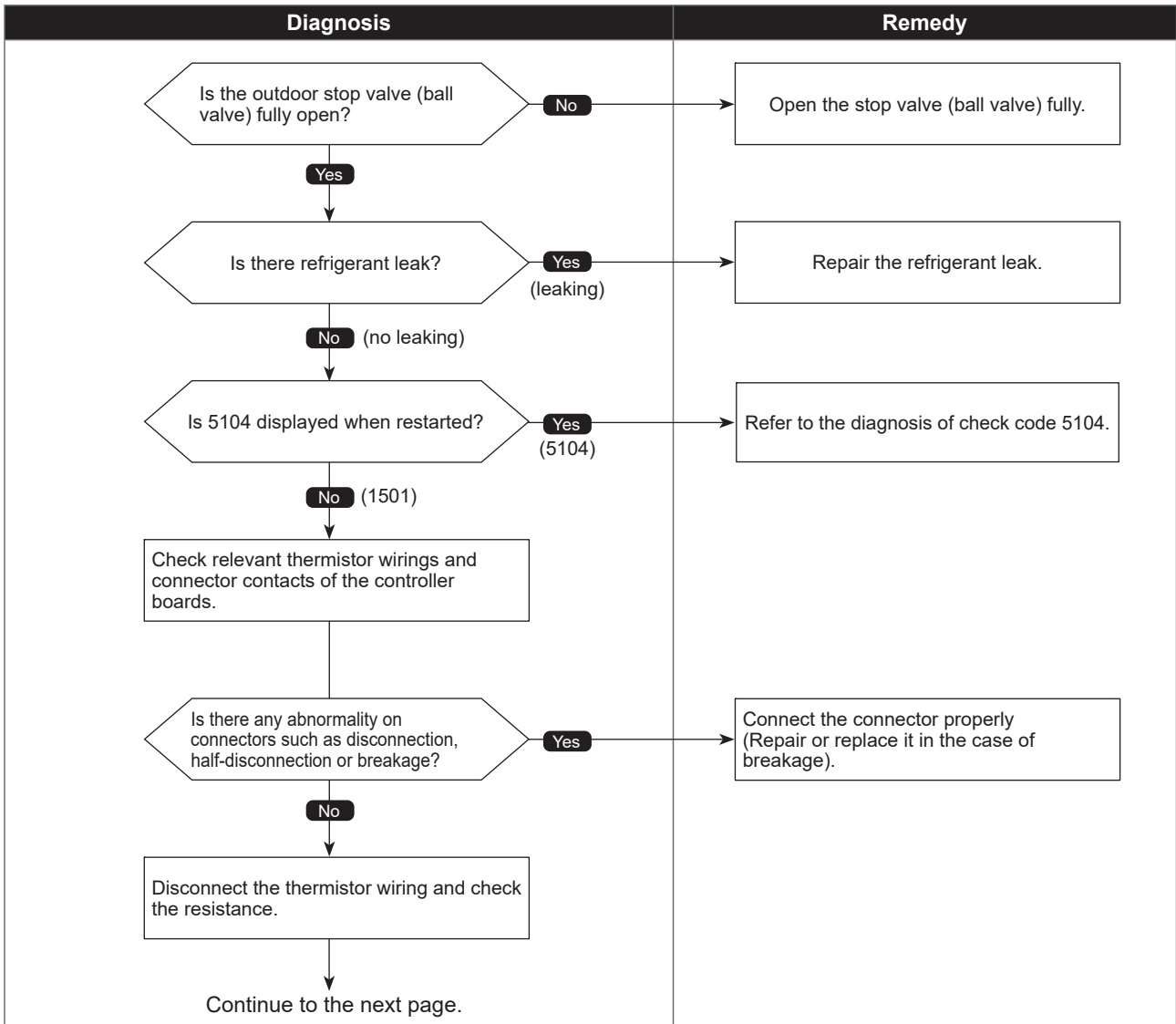

●Diagnosis of defects

Make sure to turn the power OFF before connecting/disconnecting any connectors, or replacing boards.

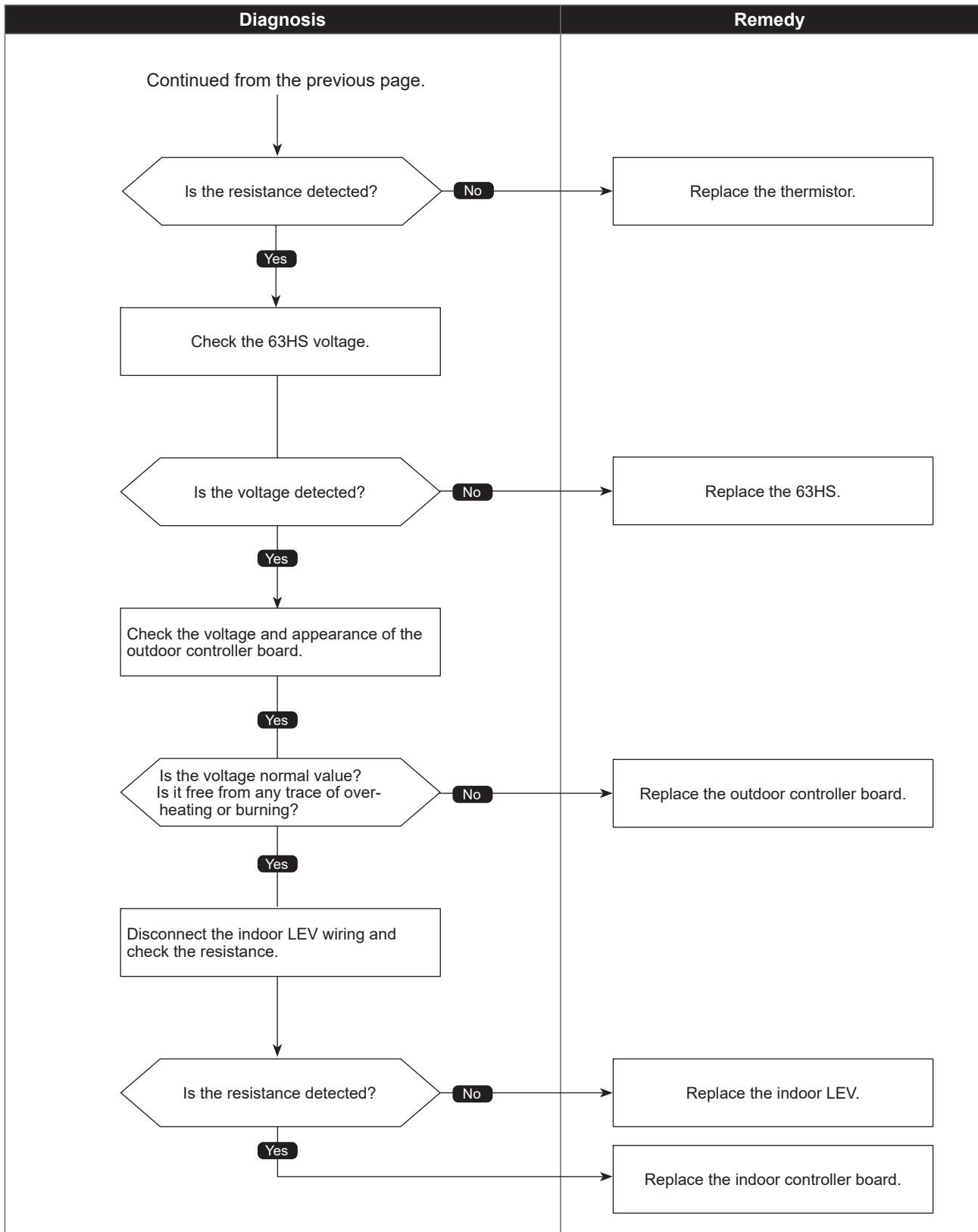

Closed valve in cooling mode

Abnormal points and detection methods	Causes and checkpoints
<p>If stop valve is closed during cooling operation.</p> <p>When both of the following temperature conditions have been satisfied for 20 minutes or more during cooling operation.</p> <ol style="list-style-type: none"> 1. TH22j - TH21j] -3.6°F [-2°C] 2. TH23j - TH21j] -3.6°F [-2°C] <p>Note: For indoor unit, the abnormality is detected if an operating unit satisfies the condition.</p>	<p>① Outdoor liquid/gas valve is closed. ② Malfunction of outdoor LEV (LEV-A) (blockage)</p> <p>TH21: Indoor intake temperature thermistor TH22: Indoor liquid pipe temperature thermistor LEV: Linear expansion valve</p>

●Diagnosis of defects

Make sure to turn the power OFF before connecting/disconnecting any connectors, or replacing boards.

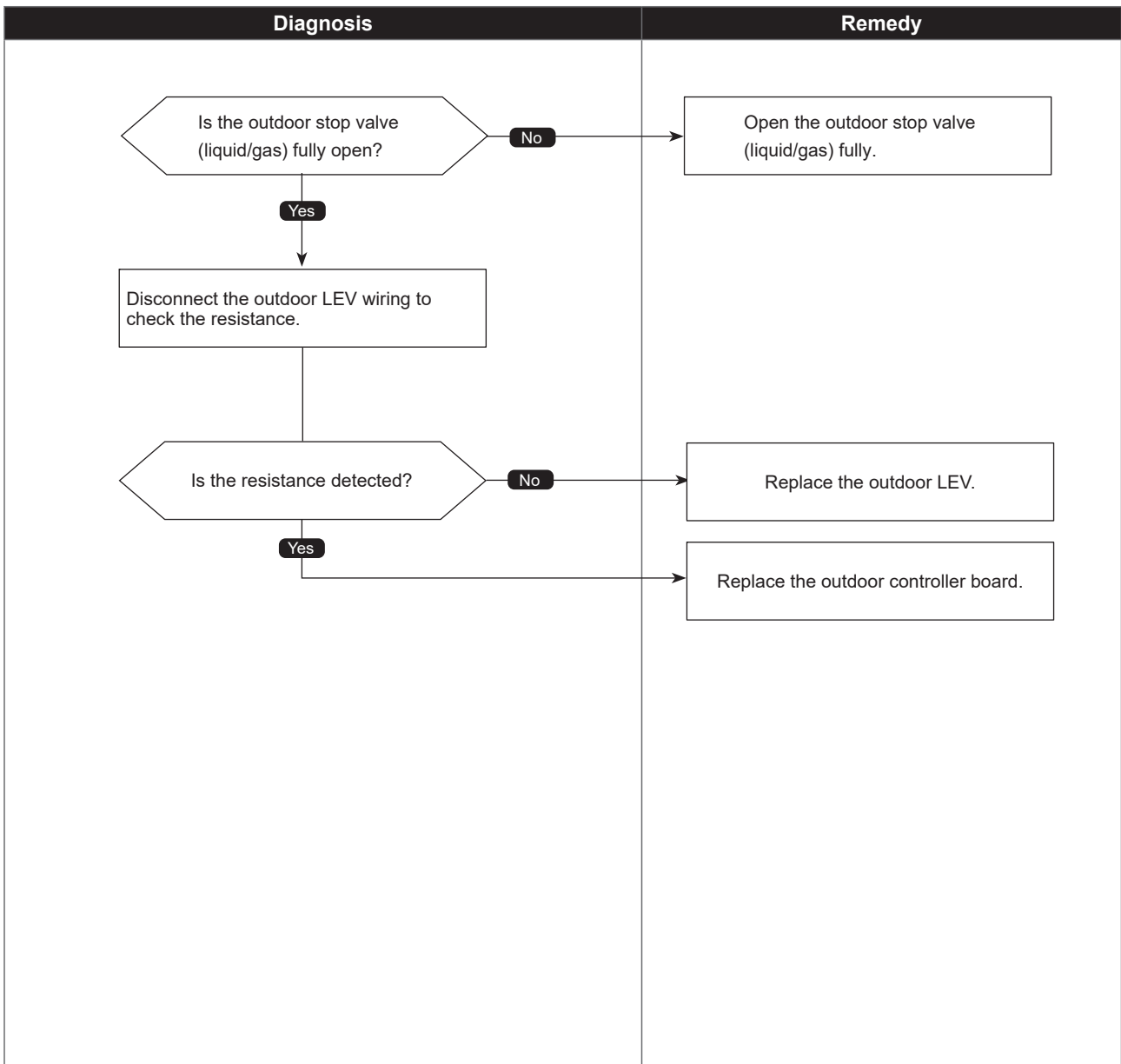

Freeze protection of Branch box or Indoor unit

Abnormal points and detection methods	Causes and checkpoints
<p>The purpose of the check code is to prevent indoor unit from freezing or dew condensation which is caused when a refrigerant keeps flowing into the unit in STOP.</p> <p>When all of the following conditions are satisfied:</p> <ol style="list-style-type: none"> 1. The compressor is operating in COOL mode. 2. 15 minutes have passed after the startup of the compressor, or the change in the number of operating indoor units is made (including a change by turning thermo-ON/OFF). 3. After the condition 2 above is satisfied, the thermistor of indoor unit in STOP detects TH22j [23°F [-5°C] for 5 consecutive minutes. 	<ol style="list-style-type: none"> 1 Wrong piping connection between indoor unit and branch box 2 Miswiring between indoor unit and branch box 3 Miswiring of LEV in branch box 4 Malfunction of LEV in branch box

●Diagnosis of defects

Make sure to turn the power OFF before connecting/disconnecting any connectors, or replacing boards.

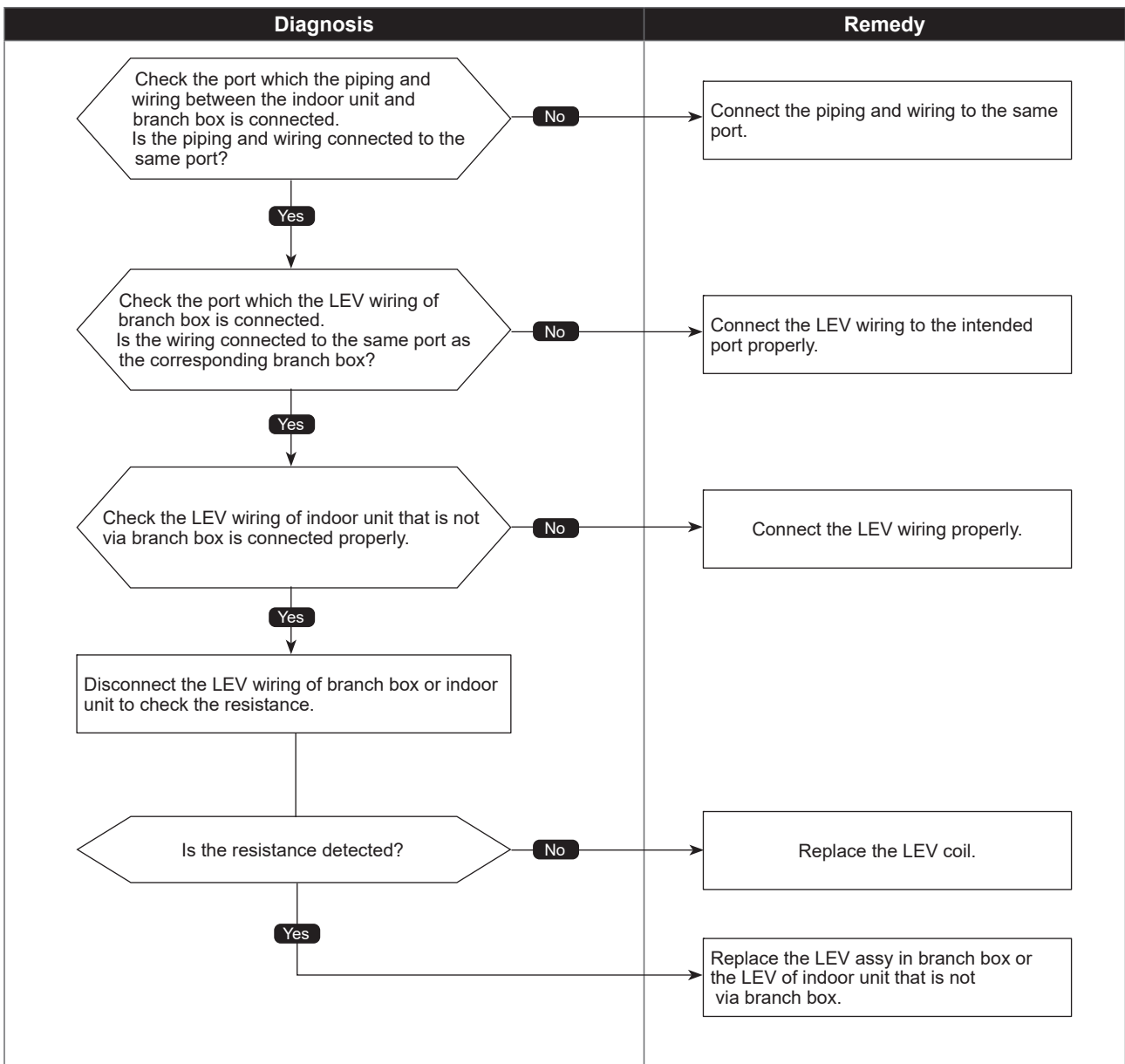

4-way valve trouble in heating mode

Abnormal points and detection methods	Causes and checkpoints
<p>If 4-way valve does not operate during heating operation.</p> <p>When any of the following temperature conditions is satisfied for 3 minutes or more during heating operation when the outdoor temperature is -4°F [-20°C] or more:</p> <ol style="list-style-type: none"> 1. TH22j - TH21j [-18°F [-10°C] 2. TH23j - TH21j [-18°F [-10°C] 3. TH22j [37.4°F [3:]] 4. TH23j [37.4°F [3:]] <p>Note: For indoor unit, the abnormality is detected if an operating unit satisfies the condition.</p>	<ol style="list-style-type: none"> ① 4-way valve failure ② Disconnection or failure of 4-way valve coil ③ Clogged drain pipe ④ Disconnection or loose connection of connectors ⑤ Malfunction of input circuit on outdoor multi controller circuit board ⑥ Defective outdoor power circuit board <p>TH21: Indoor intake temperature thermistor (RT11 or TH1) TH22: Indoor liquid pipe temperature thermistor (RT13 or TH2) TH23: Indoor gas pipe temperature thermistor (TH-A to E)</p>

●Diagnosis of defects

Make sure to turn the power OFF before connecting/disconnecting any connectors, or replacing boards.

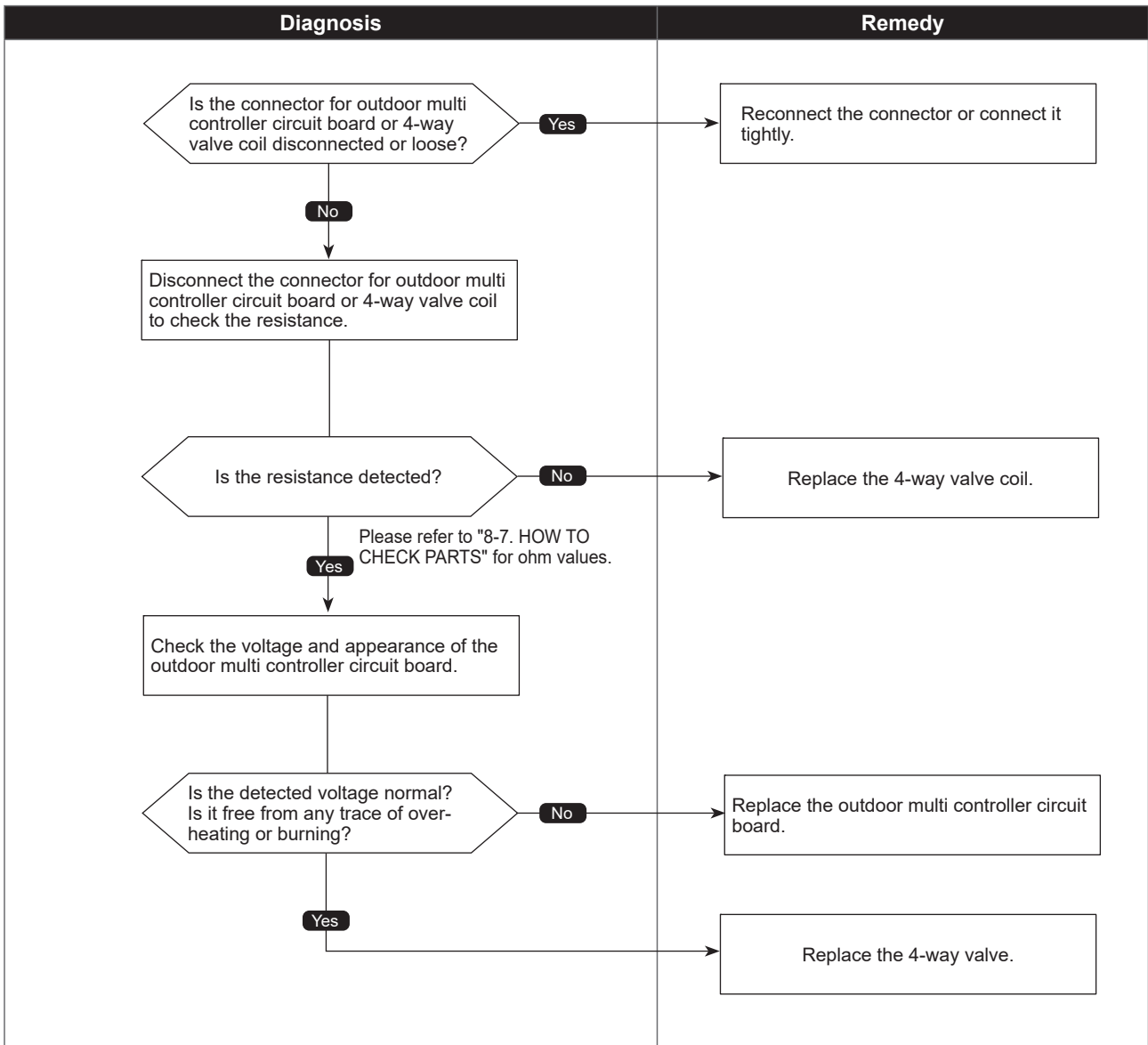

Out-of-range outside air temperature

Abnormal points and detection methods	Causes and checkpoints
<p>① When the thermistor temperature of -24°F[-31.1°C] or below has continuously been detected for 3 minutes during heating operation (during compressor operation), the unit makes an error stop and "3121" appears on the LED1 and LED2.</p> <p>② The compressor restarts when the thermistor temperature is -14°F [-25.6°C] or above.</p> <p>③ If the unit is turned OFF, the outdoor temperature error will be canceled.</p>	<p>① Outdoor air temperature</p> <p>② Thermistor failure</p> <p>③ Wire failure</p> <p>④ Defective outdoor controller board</p>

●Diagnosis of defects

Make sure to turn the power OFF before connecting/disconnecting any connectors, or replacing boards.

Diagnosis	Remedy
<p>Check the outdoor air temperature.</p> <p>Is the outdoor air temperature -24°F [-31.1°C] or higher?</p> <p>Yes</p> <p>Check the resistance of TH7.</p> <p>Is the resistance normal?</p> <p>Yes</p> <p>Check for pinched lead wire, condition of wire coating and disconnected wire.</p> <p>Is wire condition normal?</p> <p>Yes</p>	<p>Use in operation range, which is -14°F [-25.6°C] or more in heating mode.</p> <p>Replace the TH7.</p> <p>Remove the abnormal point.</p> <p>Replace the outdoor controller board.</p>

Abnormal points and detection methods	Causes and checkpoints
<p>If overcurrent of DC bus or compressor is detected before 30 seconds after the compressor starts operating.</p>	<ul style="list-style-type: none"> ① Closed stop valve ② Decrease of power supply voltage ③ Looseness, disconnection, or wrong phase of compressor wiring connection ④ Incorrect DIP-SW setting of model selection on the outdoor controller board ⑤ Defective compressor ⑥ Defective outdoor power circuit board

●Diagnosis of defects

Make sure to turn the power OFF before connecting/disconnecting any connectors, or replacing boards.

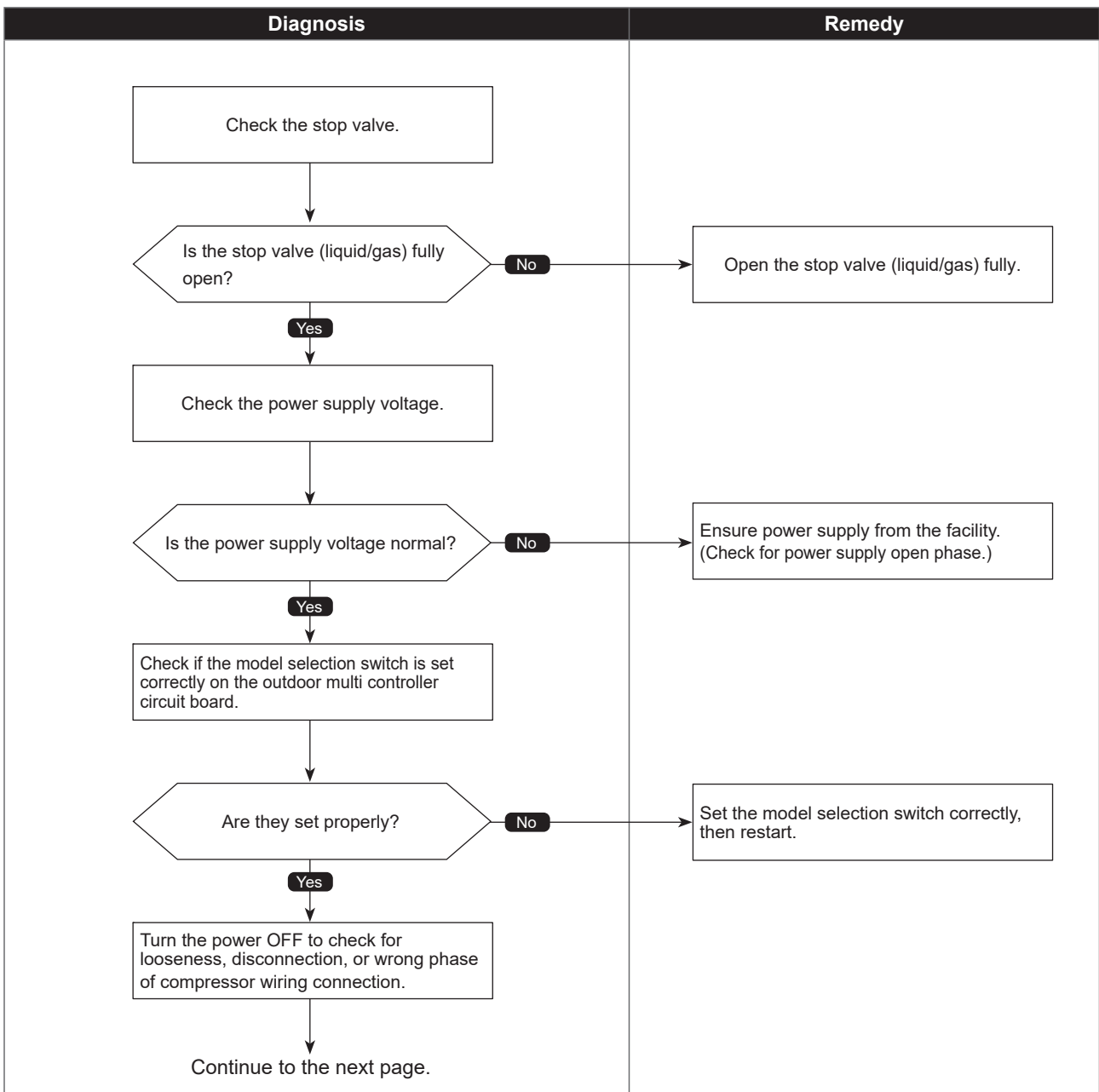

●Diagnosis of defects

Make sure to turn the power OFF before connecting/disconnecting any connectors, or replacing boards.

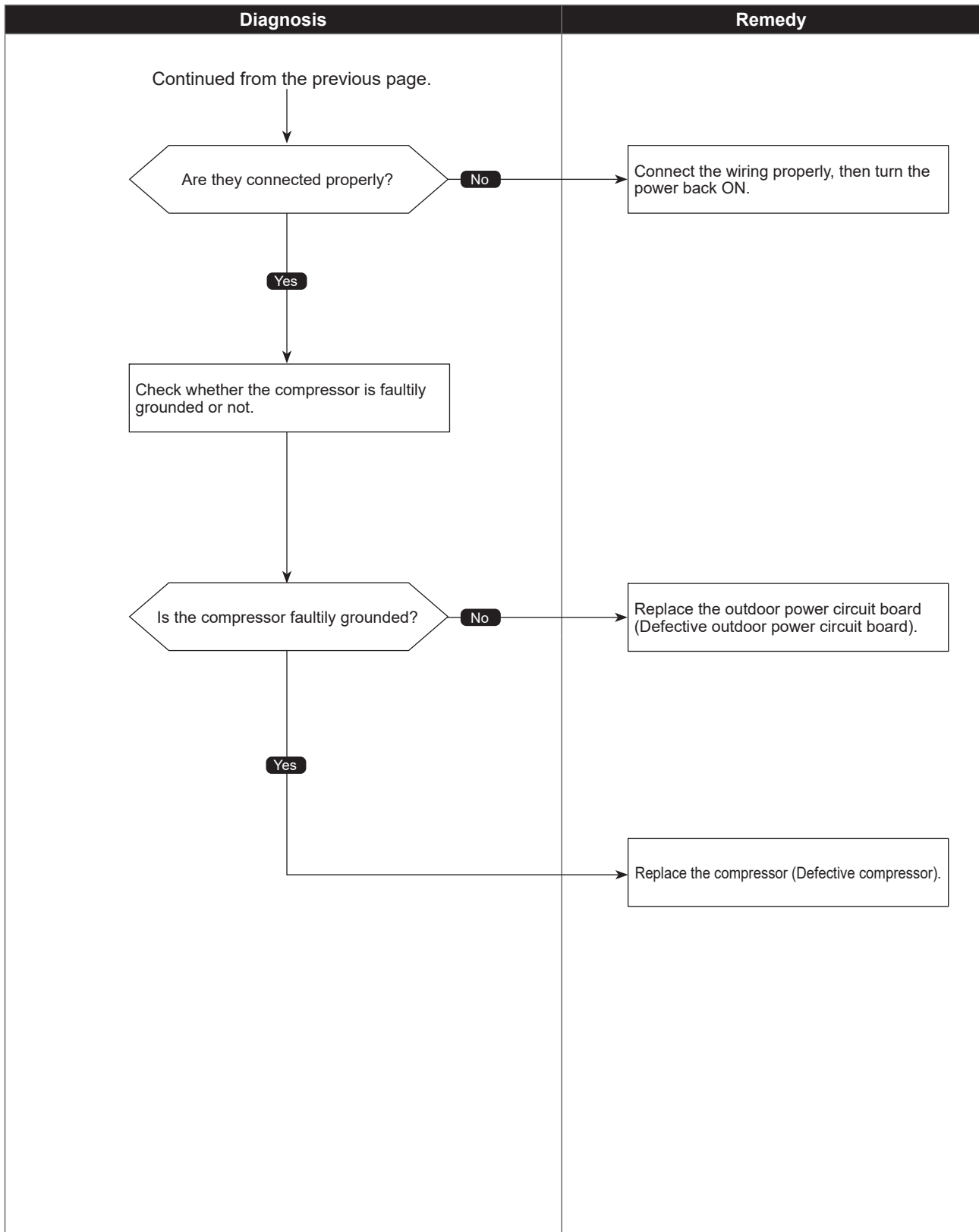

Compressor overcurrent interruption/failure in 12 VDC power supply circuit on power circuit board

Abnormal points and detection methods	Causes and checkpoints
<p>① If overcurrent of compressor is detected after 30 seconds since the compressor starts operating.</p> <p>② If 12 VDC power is not supplied from the 12 VDC supply circuit on the power circuit board.</p>	<p>① Closed outdoor stop valve</p> <p>② Decrease of power supply voltage</p> <p>③ Looseness, disconnection or reverse phase of compressor wiring connection</p> <p>④ Malfunction of indoor/outdoor fan</p> <p>⑤ Short-cycle of indoor/outdoor unit</p> <p>⑥ Model selection error upon replacement of outdoor multi controller circuit board</p> <p>⑦ Malfunction of input circuit on outdoor multi controller circuit board</p> <p>⑧ Defective compressor</p> <p>⑨ Defective outdoor power circuit board</p>

●Diagnosis of defects

Make sure to turn the power OFF before connecting/disconnecting any connectors, or replacing boards.

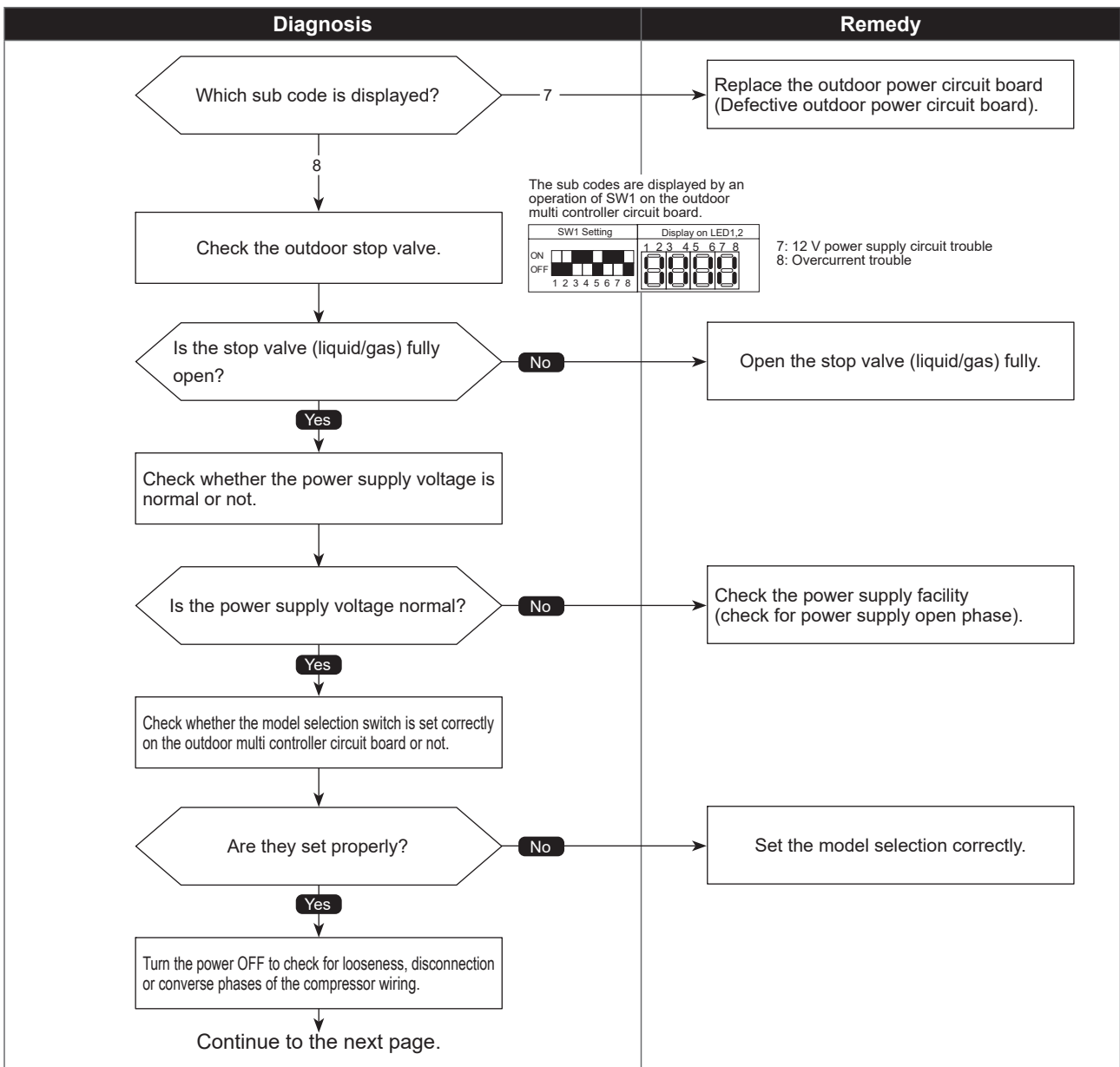

Compressor overcurrent interruption/failure in 12 VDC power supply circuit on power circuit board

●Diagnosis of defects

Make sure to turn the power OFF before connecting/disconnecting any connectors, or replacing boards.

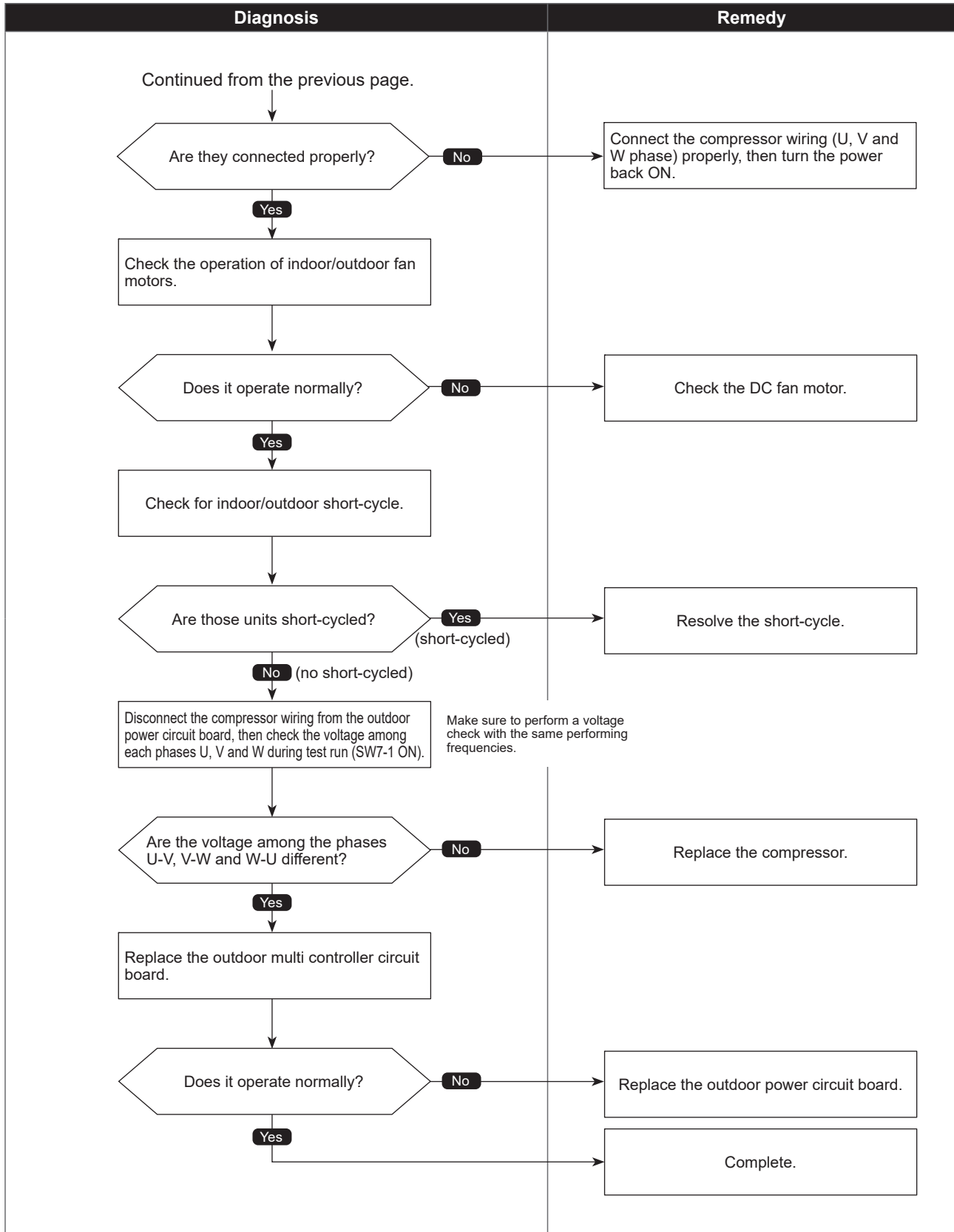

Voltage shortage /Overvoltage/PAM error/L1 open phase/ Primary current sensor error/Power synchronization signal error

Abnormal points and detection methods	Causes and checkpoints
<p>If any of following symptoms are detected;</p> <ul style="list-style-type: none"> ●Decrease of DC bus voltage to 200 V (Single-phase), 350 V (3-phase) ●Increase of DC bus voltage to 400 V (Single-phase), 760 V (3-phase) ●DC bus voltage stays at 310 V or less for consecutive 30 seconds when the operational frequency is over 20 Hz. ●When any of following conditions is satisfied while the detections value of primary current is 0.1 A or less. <ol style="list-style-type: none"> 1. The operational frequency is 40 Hz or more. 2. The compressor current is 6 A or more. 	<ol style="list-style-type: none"> ① Decrease/increase of power supply voltage ② L1 open-phase (3-phase only) ③ Primary current sensor failure ④ Disconnection of compressor wiring ⑤ Malfunction of 52C relay ⑥ Defective outdoor power circuit board ⑦ Malfunction of 52C relay driving circuit on outdoor multi controller circuit board ⑧ Disconnection of CN5 (3-phase only) ⑨ Disconnection of CN2 ⑩ Malfunction of primary current detecting circuit on outdoor power circuit board ⑪ Malfunction of resistor connected to 52C relay on outdoor power circuit board (3-phase only)

●**Diagnosis of defects**
Make sure to turn the power OFF before connecting/disconnecting any connectors, or replacing boards.

Single phase: single phase model
3-phase: three phase for wire model

The black square (■) indicates a switch position.

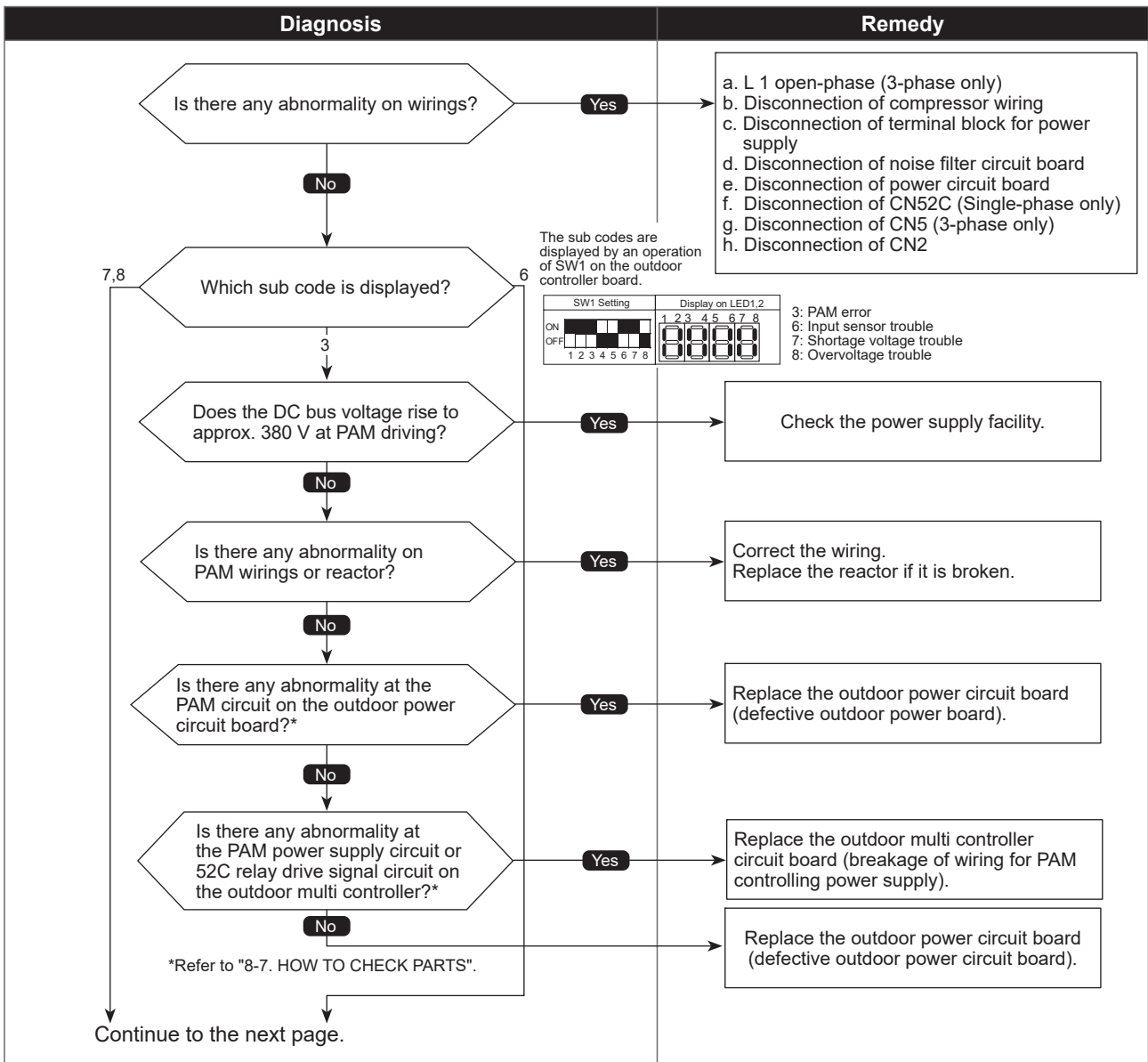

●Diagnosis of defects

Make sure to turn the power OFF before connecting/disconnecting any connectors, or replacing boards.

The black square (■) indicates a switch position.

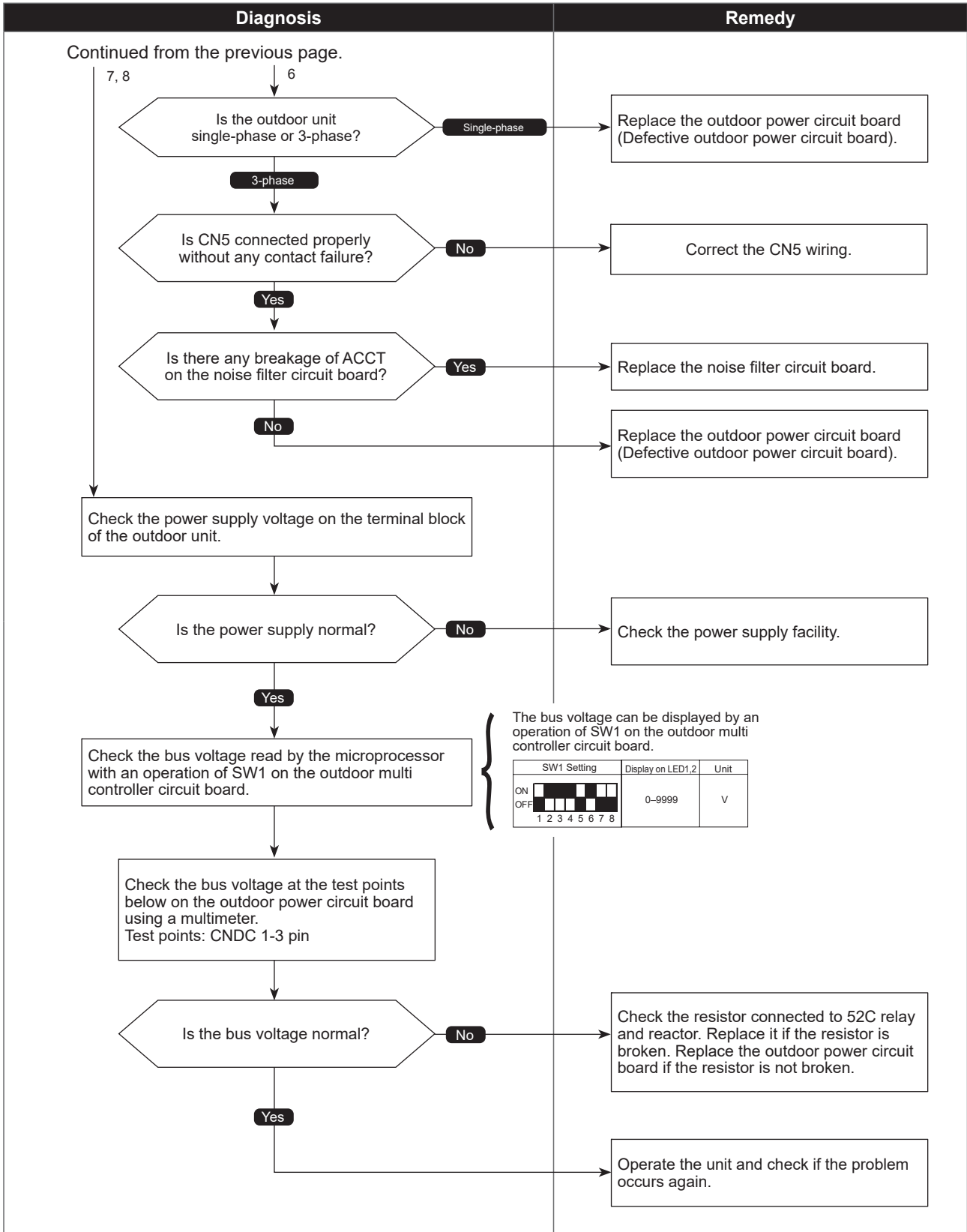

Heat sink temperature trouble

Abnormal points and detection methods	Causes and checkpoints
<p>If TH8 detects a temperature outside the specified range during compressor operation.</p> <p>TH8: Thermistor <Heat sink></p>	<ul style="list-style-type: none"> ① Blocked outdoor fan ② Malfunction of outdoor fan motor ③ Blocked airflow path ④ Rise of ambient temperature ⑤ Characteristic defect of thermistor ⑥ Malfunction of input circuit on outdoor power board ⑦ Malfunction of outdoor fan driving circuit

●Diagnosis of defects

Make sure to turn the power OFF before connecting/disconnecting any connectors, or replacing boards.

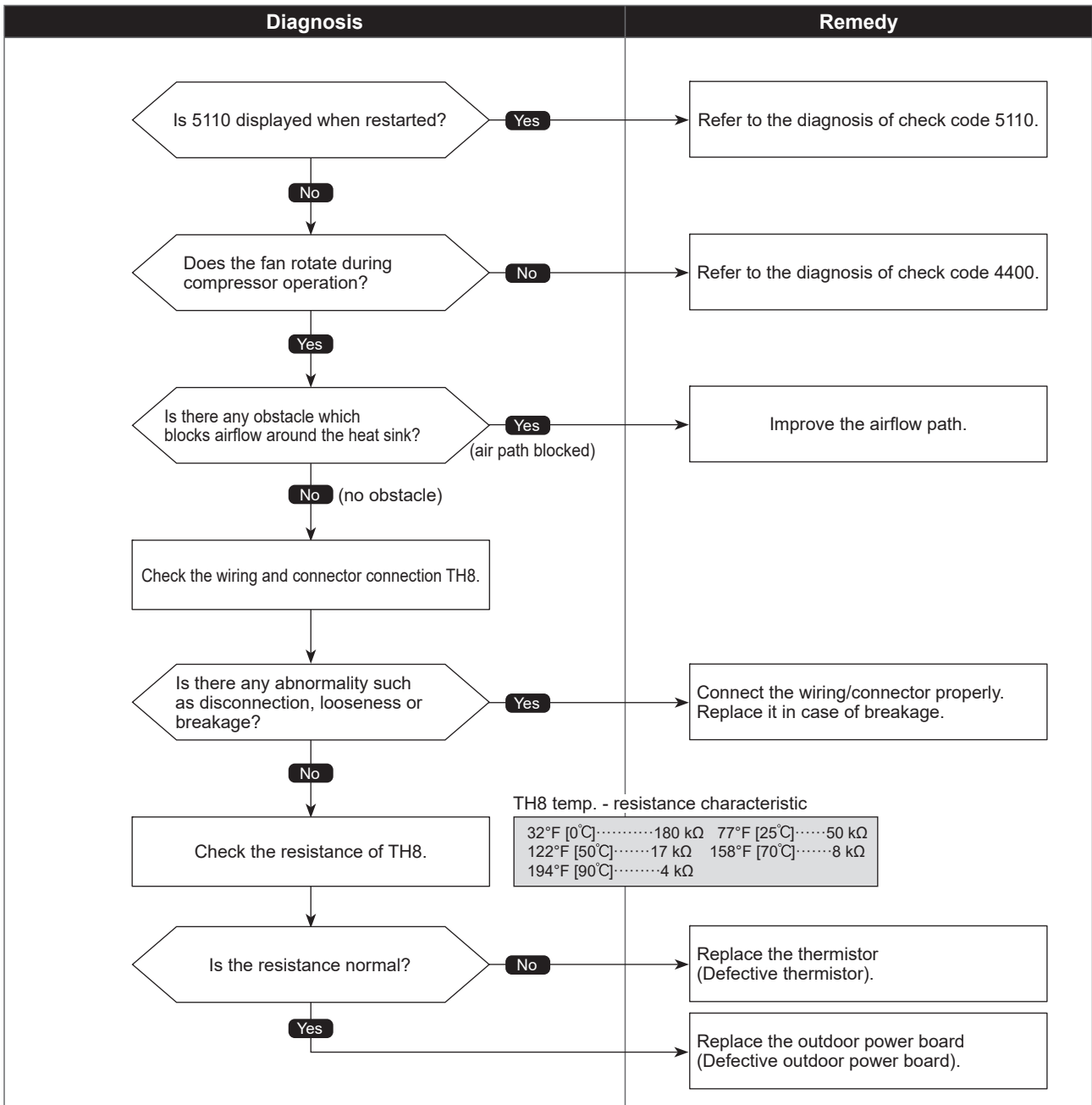

Power module trouble or overcurrent trouble

Abnormal points and detection methods	Causes and checkpoints
<p>If overcurrent of DC bus or compressor is detected 30 seconds after the compressor starts operating. To determine the source of abnormality, either the compressor or the power module, drive the power module forcibly.</p>	<ul style="list-style-type: none"> ① Closed outdoor stop valve ② Decrease of power supply voltage ③ Disconnection, looseness or conversed connection of compressor wiring ④ Defective compressor ⑤ Defective outdoor power circuit board

●Diagnosis of defects

Make sure to turn the power OFF before connecting/disconnecting any connectors, or replacing boards.

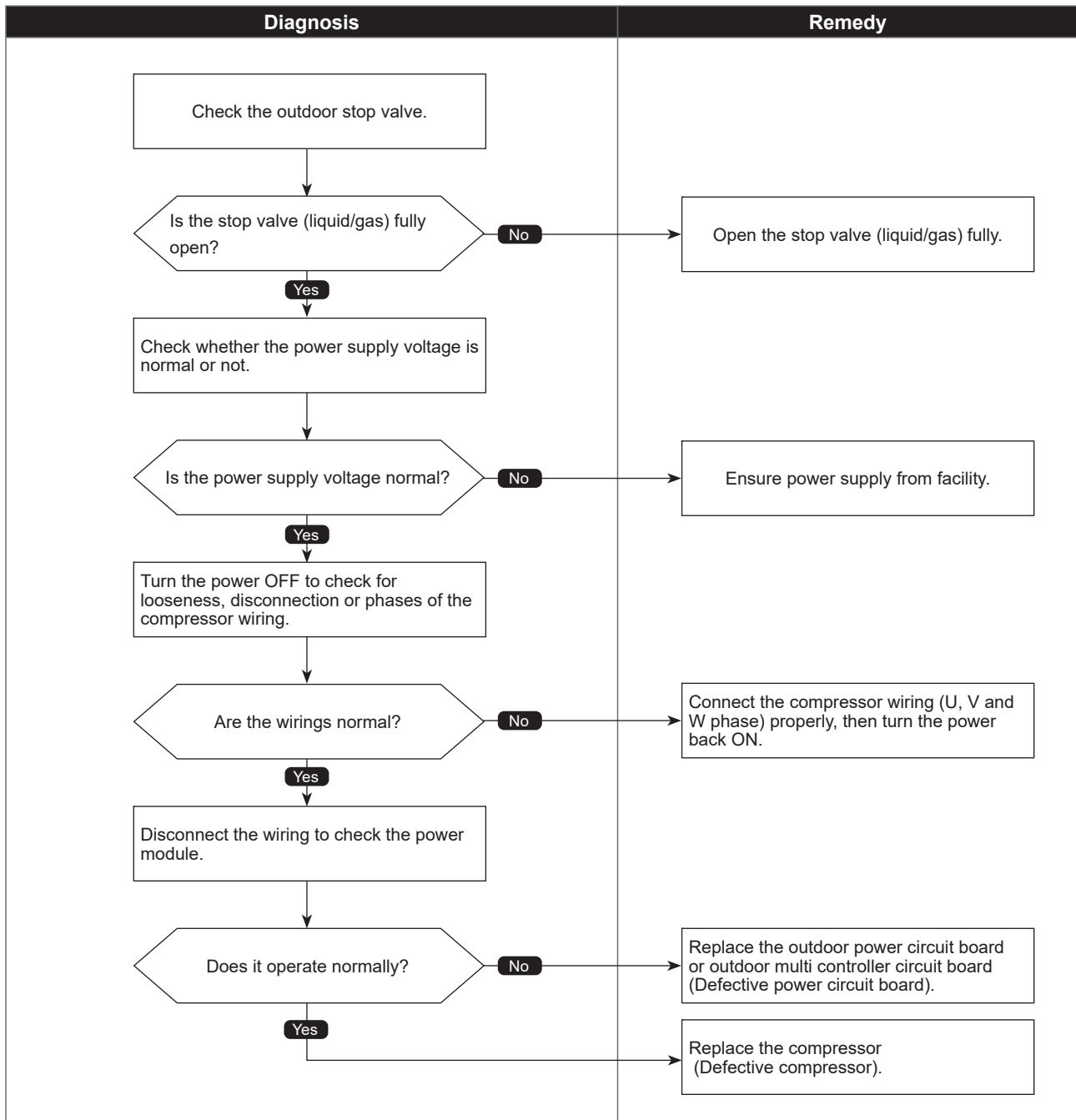

Abnormal points and detection methods	Causes and checkpoints
If no rotational frequency is detected, or detected a value outside the specified range during fan motor operation.	① Malfunction of fan motor ② Disconnection of CNF connector ③ Defective outdoor controller board

●Diagnosis of defects

Make sure to turn the power OFF before connecting/disconnecting any connectors, or replacing boards.

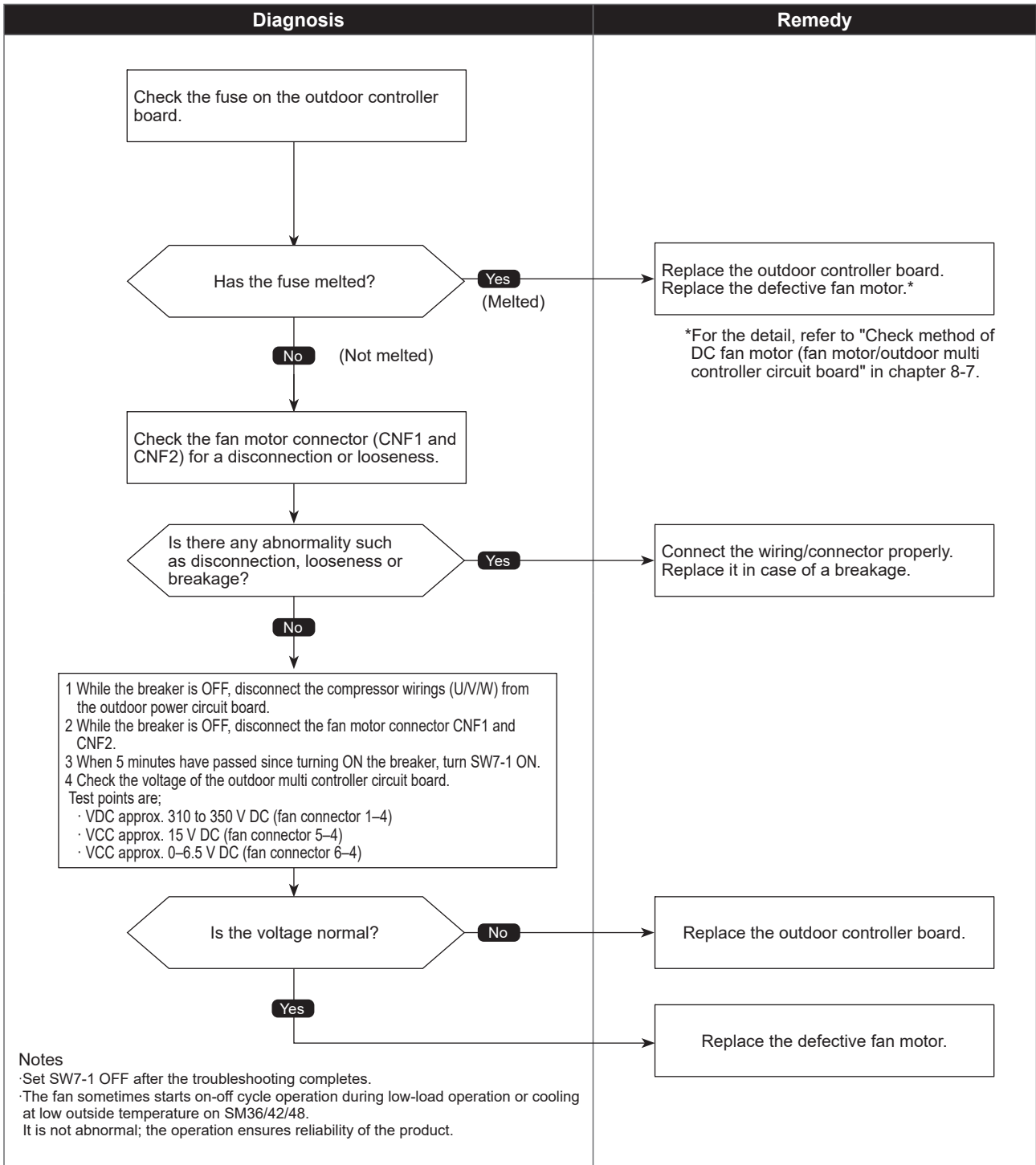

Compressor temperature thermistor (TH4) open/short

<Detected in outdoor unit>

Abnormal points and detection methods	Causes and checkpoints
<p>If TH4 detects to be open/short. (The open/short detection is disabled for 10 minutes after compressor starts, during defrosting operation, or for 10 minutes after returning from the defrosting operation. The detection is also disabled when the outdoor temperature is 41°F [5°C] or less in cooling operation, and -4°F [-20°C] or less in heating.) Open: 37.4°F [3°C] or less Short: 422.6°F [217°C] or more TH4: Thermistor <Compressor></p>	<p>① Disconnection or contact failure of connectors ② Characteristic defect of thermistor ③ Defective outdoor controller board</p>

●Diagnosis of defects

Make sure to turn the power OFF before connecting/disconnecting any connectors, or replacing boards.

The black square (■) indicates a switch position.

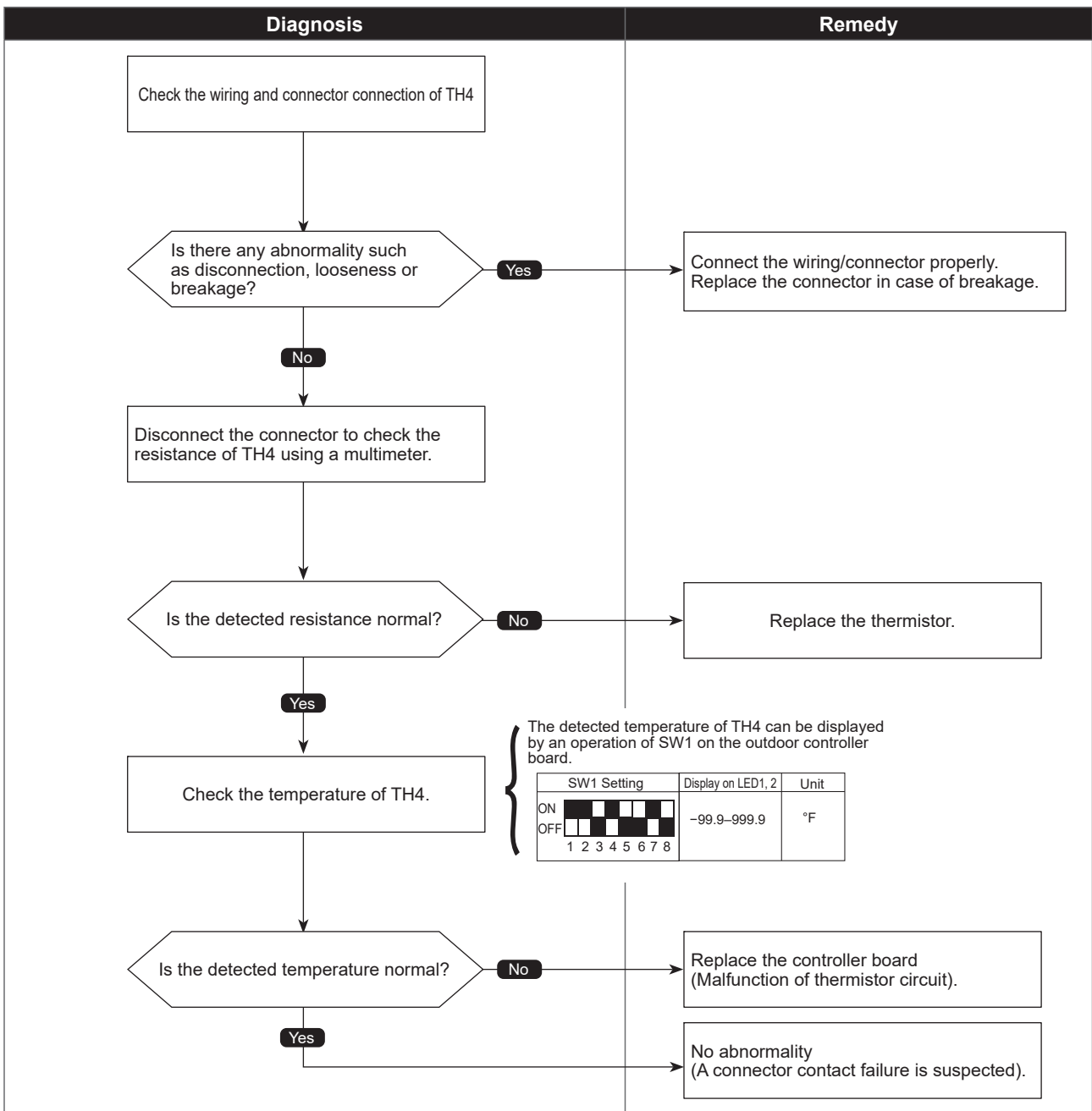

Suction pipe temperature thermistor (TH6) open/short

<Detected in outdoor unit>

Abnormal points and detection methods	Causes and checkpoints
<p>If TH6 detects to be open/short. (The open/short detection is disabled during 10 seconds to 10 minutes after compressor starts, during defrosting operation, or for 10 minutes after returning from the defrosting operation.) Open: -40°F [-40°C] or less Short: 194°F [90°C] or more TH6: Thermistor <Suction pipe></p>	<p>① Disconnection or contact failure of connectors ② Characteristic defect of thermistor ③ Defective outdoor controller board</p>

●Diagnosis of defects

Make sure to turn the power OFF before connecting/disconnecting any connectors, or replacing boards.

The black square (■) indicates a switch position.

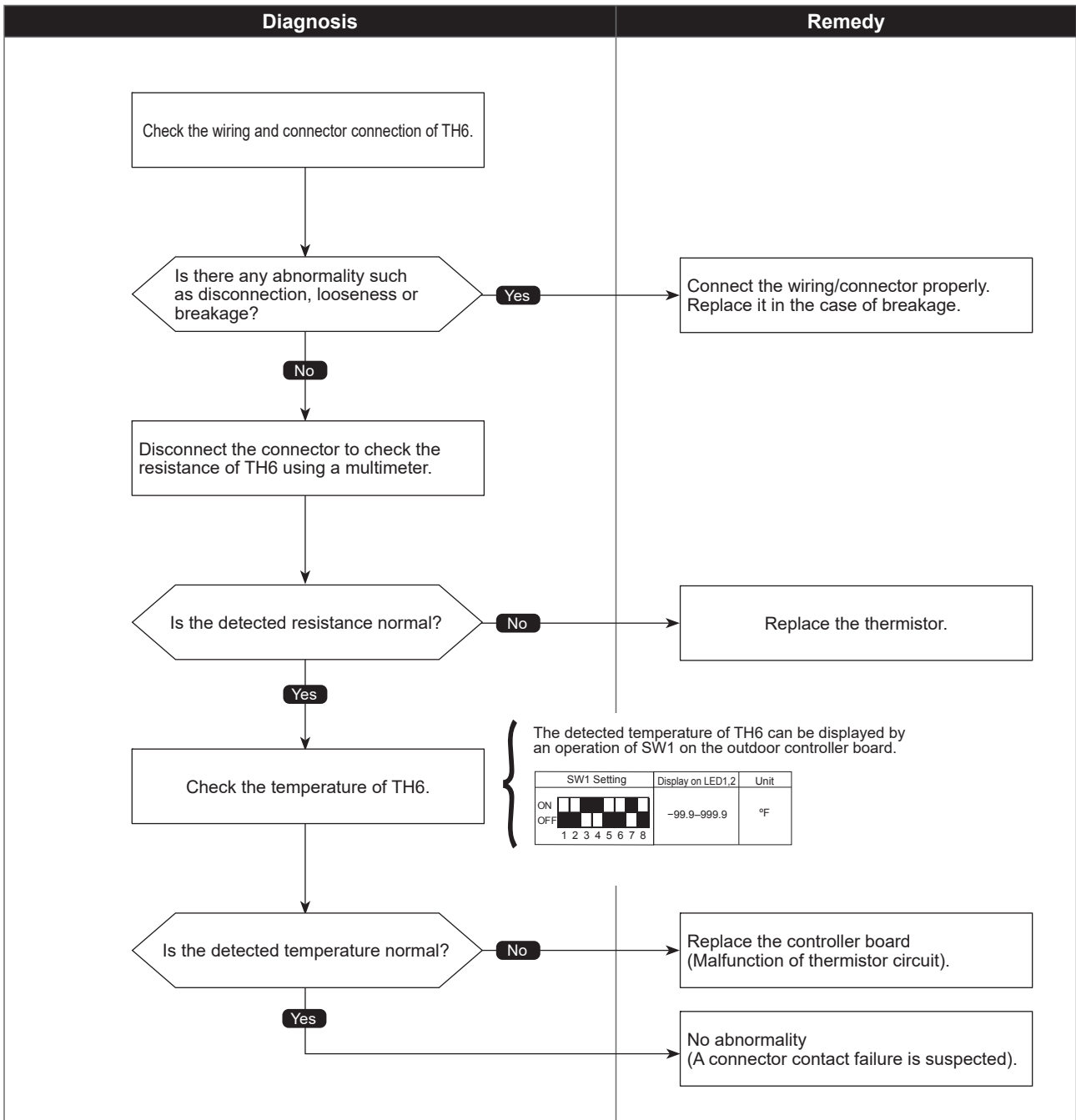

Outdoor liquid pipe temperature thermistor (TH3) open/short

Abnormal points and detection methods	Causes and checkpoints
If TH3 detects to be open/short. (The open/short detection is disabled during 10 seconds to 10 minutes after compressor starts, during defrosting operation, or for 10 minutes after returning from the defrosting operation.) Open: -40°F [-40°C] or less Short: 194°F [90°C] or more TH3: Thermistor <Outdoor liquid pipe>	① Disconnection or contact failure of connectors ② Characteristic defect of thermistor ③ Defective outdoor controller board

●Diagnosis of defects

Make sure to turn the power OFF before connecting/disconnecting any connectors, or replacing boards.

The black square (■) indicates a switch position.

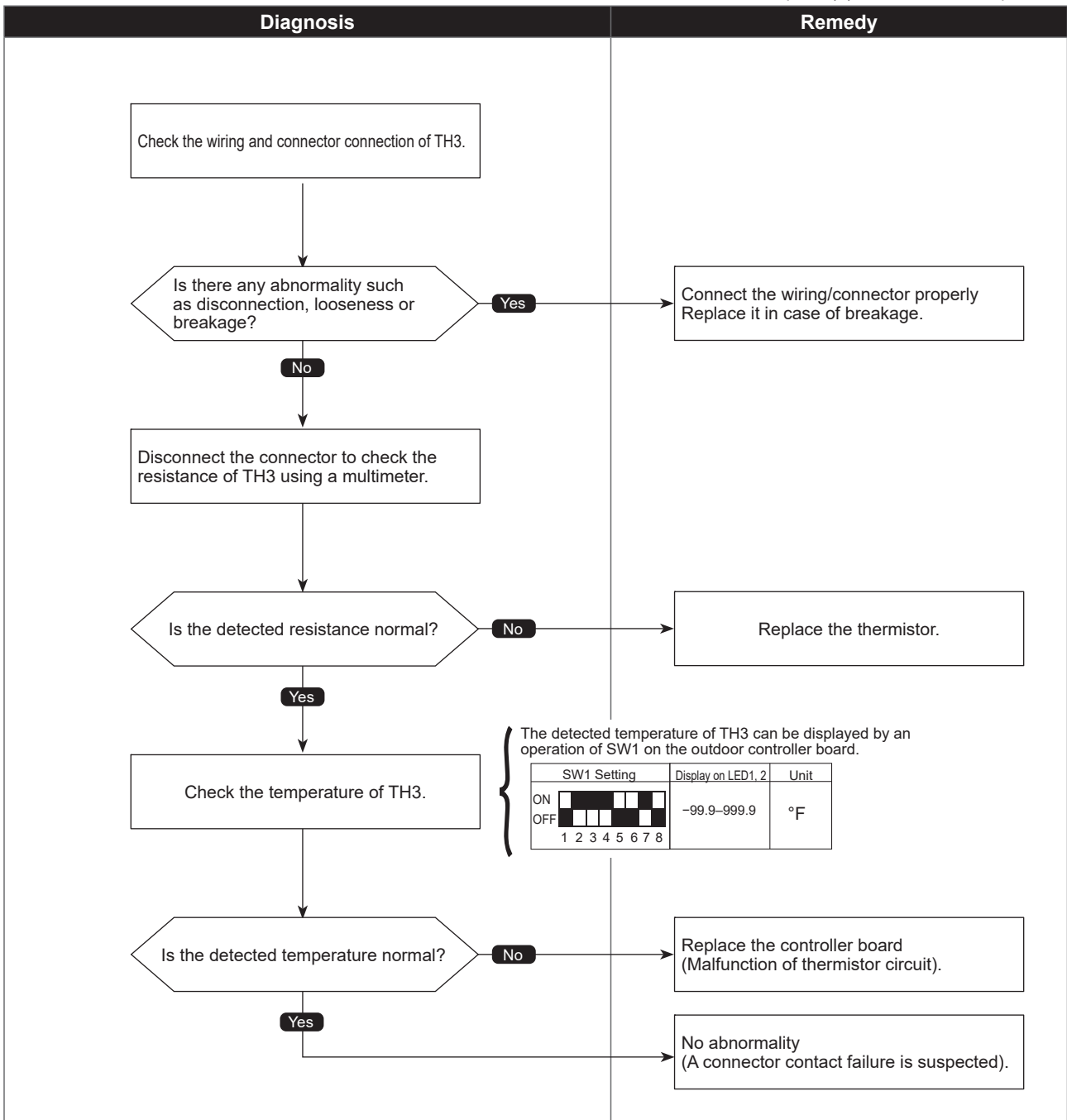

Ambient temperature thermistor (TH7) open/short

Abnormal points and detection methods	Causes and checkpoints
If TH7 detects to be open/short Open: -40°F [-40:] or less Short: 194°F [90:] or more TH7: Thermistor <Ambient>	① Disconnection or contact failure of connectors ② Characteristic defect of thermistor ③ Defective outdoor controller board

●Diagnosis of defects

Make sure to turn the power OFF before connecting/disconnecting any connectors, or replacing boards.

The black square (■) indicates a switch position.

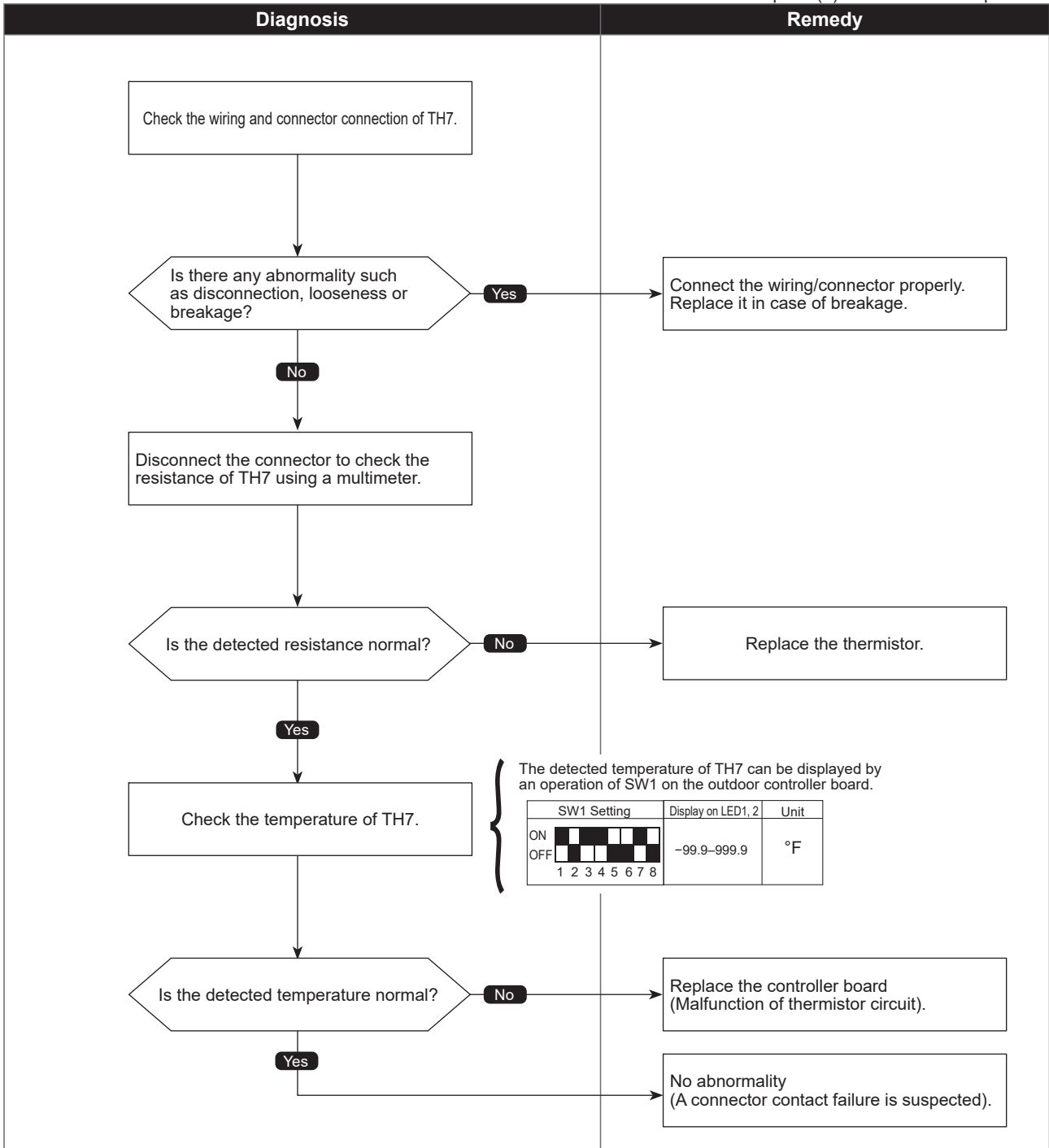

HIC pipe temperature thermistor (TH2) open/short

Abnormal points and detection methods	Causes and checkpoints
If TH2 detects to be open/short. Open: -40°F [-40:] or less Short: 194°F [90:] or more TH2: Thermistor <HIC pipe>	① Disconnection or contact failure of connectors ② Characteristic defect of thermistor ③ Defective outdoor controller board

●Diagnosis of defects

Make sure to turn the power OFF before connecting/disconnecting any connectors, or replacing boards.

The black square (■) indicates a switch position.

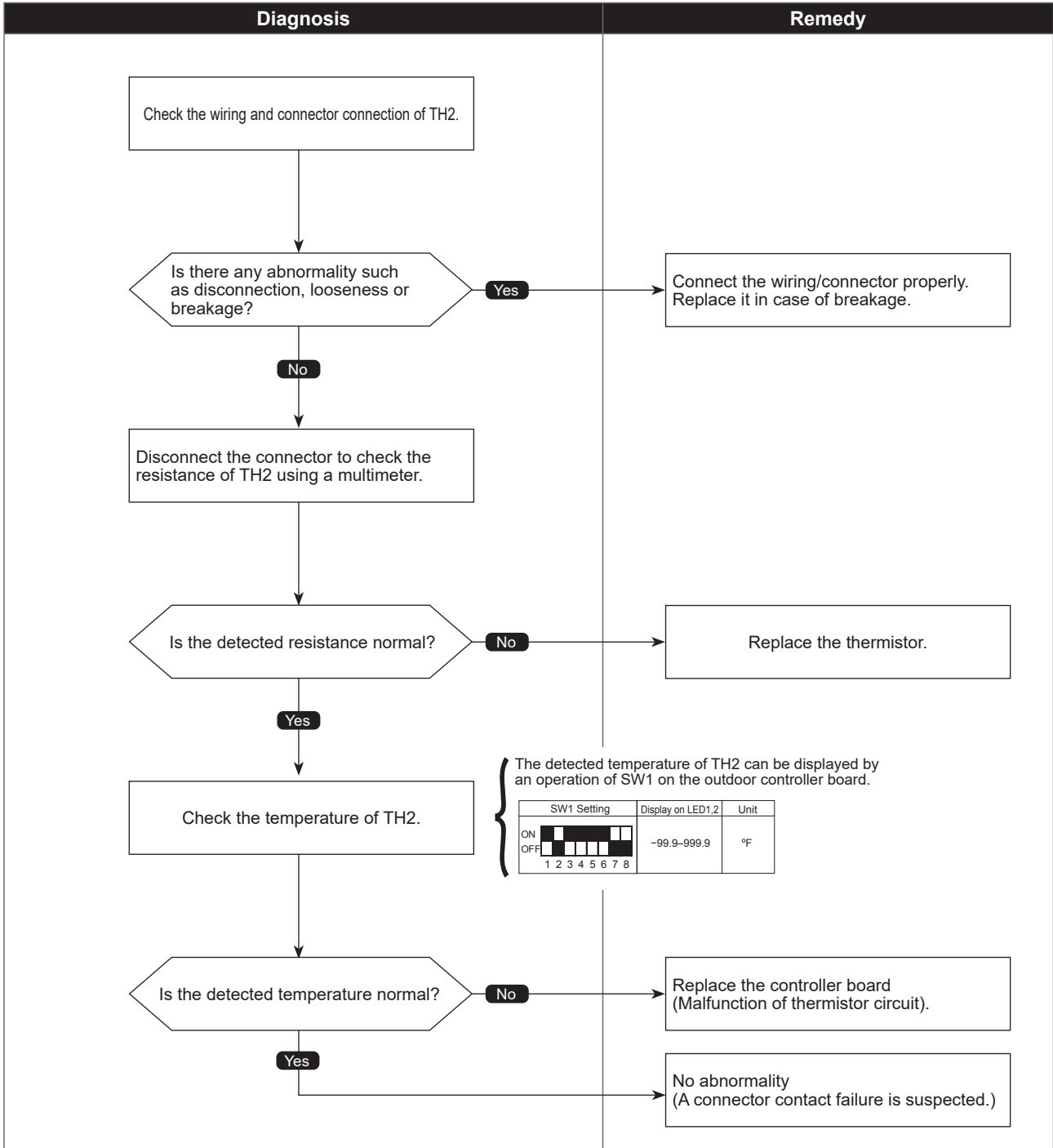

Heat sink temperature thermistor(TH8) open/short

Abnormal points and detection methods	Causes and checkpoints
If TH8 detects to be open/short. Open: -31.2°F [-35.1°C] or less Short: 338.5°F [170.3°C] or more TH8: Thermistor <Heat sink>	① Disconnection or contact failure of connectors ② Characteristic defect of thermistor ③ Defective outdoor controller board

●Diagnosis of defects

Make sure to turn the power OFF before connecting/disconnecting any connectors, or replacing boards.

The black square (■) indicates a switch position.

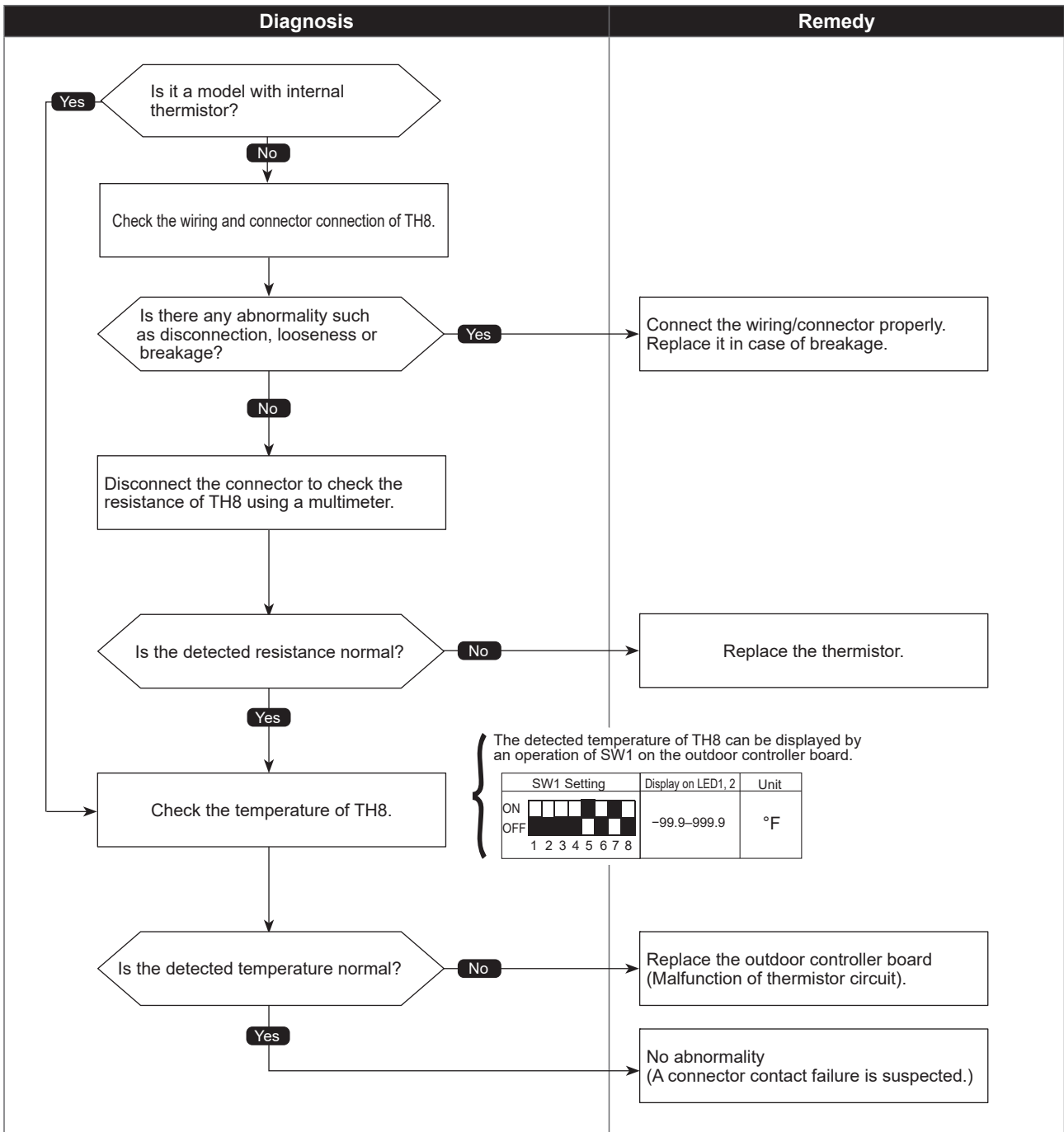

High pressure sensor (63HS) trouble

Abnormal points and detection methods	Causes and checkpoints
<p>① When the detected pressure in the high pressure sensor is 14 PSIG or less during operation, the compressor stops operation and enters into an anti-restart mode for 3 minutes.</p> <p>② When the detected pressure is 14 PSIG or less immediately before restarting, the compressor falls into an abnormal stop with a check code <5201>.</p> <p>③ For 3 minutes after compressor restarting, during defrosting operation, and for 3 minutes after returning from defrosting operation, above mentioned symptoms are not determined as abnormal.</p>	<p>① Defective high pressure sensor</p> <p>② Decrease of internal pressure caused by gas leakage</p> <p>③ Disconnection or contact failure of connector</p> <p>④ Malfunction of input circuit on outdoor controller board</p>

●Diagnosis of defects

Make sure to turn the power OFF before connecting/disconnecting any connectors, or replacing boards.

The black square (■) indicates a switch position.

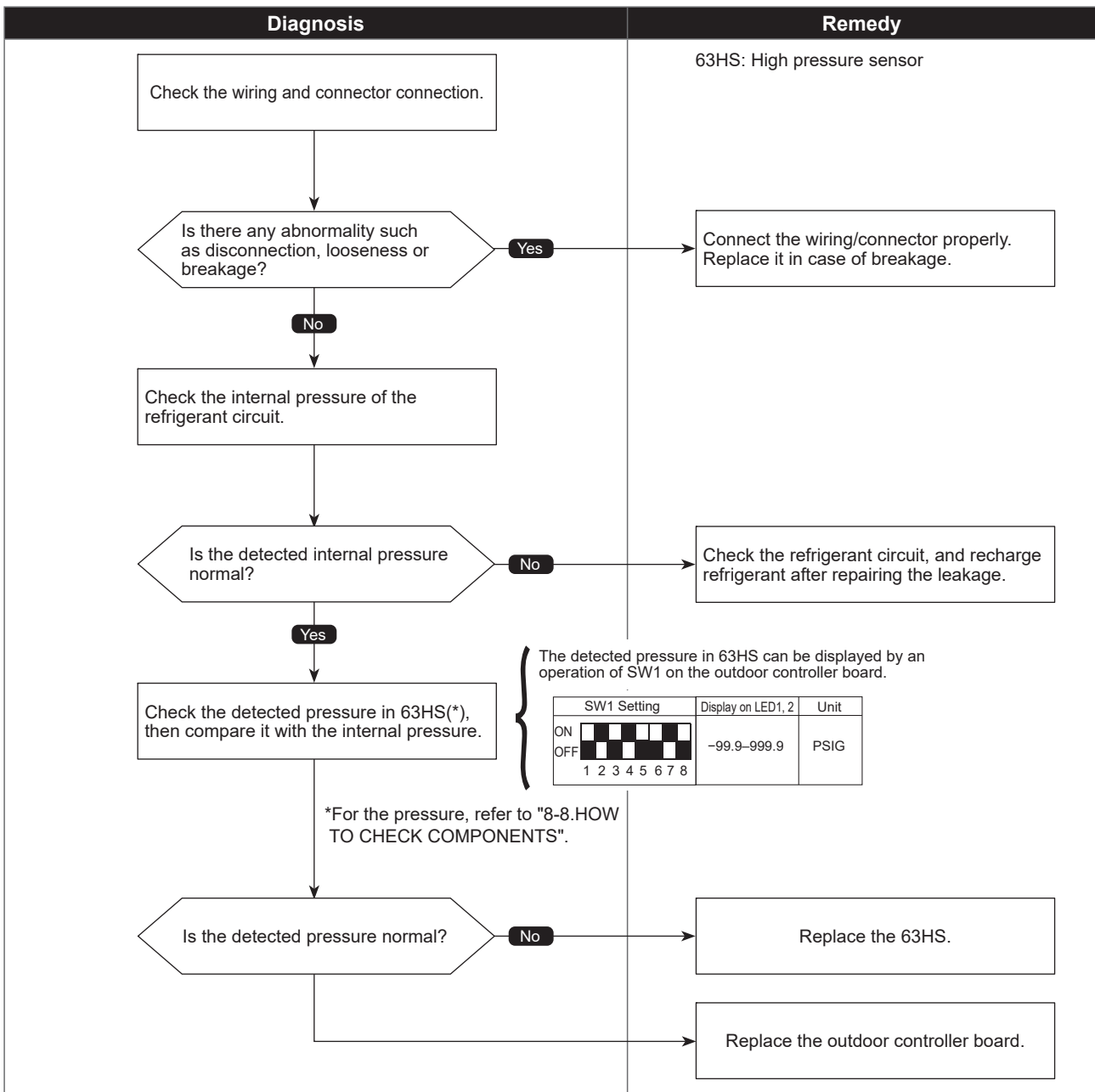

Low pressure sensor (63LS) trouble

Abnormal points and detection methods	Causes and checkpoints
<p>① When the detected pressure in the low pressure sensor is -33 PSIG or less, or 329 PSIG or more during operation, the compressor stops operation with a check code <5202>.</p> <p>② For 3 minutes after compressor restarting, during defrosting operation, and for 3 minutes after returning from defrosting operation, above mentioned symptoms are not determined as abnormal.</p>	<p>① Defective low pressure sensor</p> <p>② Decrease of internal pressure caused by gas leakage</p> <p>③ Disconnection or contact failure of connector</p> <p>④ Malfunction of input circuit on outdoor controller board</p>

●Diagnosis of defects

Make sure to turn the power OFF before connecting/disconnecting any connectors, or replacing boards.

The black square (■) indicates a switch position.

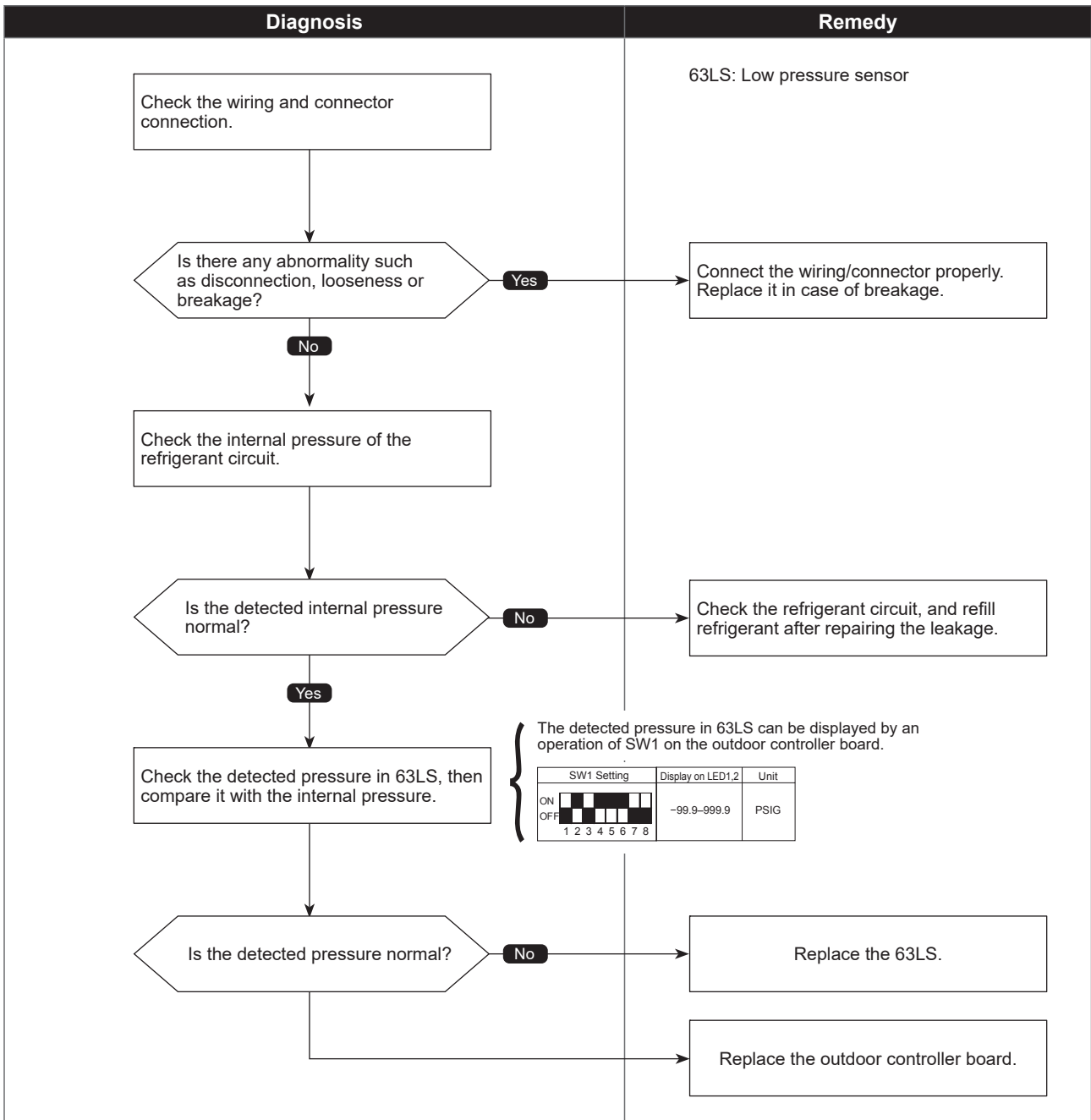

Primary current error

Abnormal points and detection methods	Causes and checkpoints									
<p>If any of the following conditions is detected:</p> <p>1 Primary current sensor detects any of the following conditions (single phase unit only):</p> <table border="1"> <thead> <tr> <th>Model name</th> <th>10 consecutive-second detection</th> <th>One-time detection</th> </tr> </thead> <tbody> <tr> <td>MXZ-SM36/48NAM</td> <td>34 A</td> <td>38 A</td> </tr> <tr> <td>MXZ-SM36/42/48NAMHZ MXZ-SM60NAM</td> <td>37 A</td> <td>40 A</td> </tr> </tbody> </table> <p>2 Secondary current sensor detects 25 A or more. 3 Secondary current sensor detects 1.0 A or less.</p>	Model name	10 consecutive-second detection	One-time detection	MXZ-SM36/48NAM	34 A	38 A	MXZ-SM36/42/48NAMHZ MXZ-SM60NAM	37 A	40 A	<p>① Decrease/trouble of power supply voltage ② Disconnection of compressor wiring ③ Current sensor trouble on outdoor power circuit board ④ Wiring through current sensor (penetration type) is not done.</p>
Model name	10 consecutive-second detection	One-time detection								
MXZ-SM36/48NAM	34 A	38 A								
MXZ-SM36/42/48NAMHZ MXZ-SM60NAM	37 A	40 A								

● Diagnosis of defects

Make sure to turn the power OFF before connecting/disconnecting any connectors, or replacing boards.

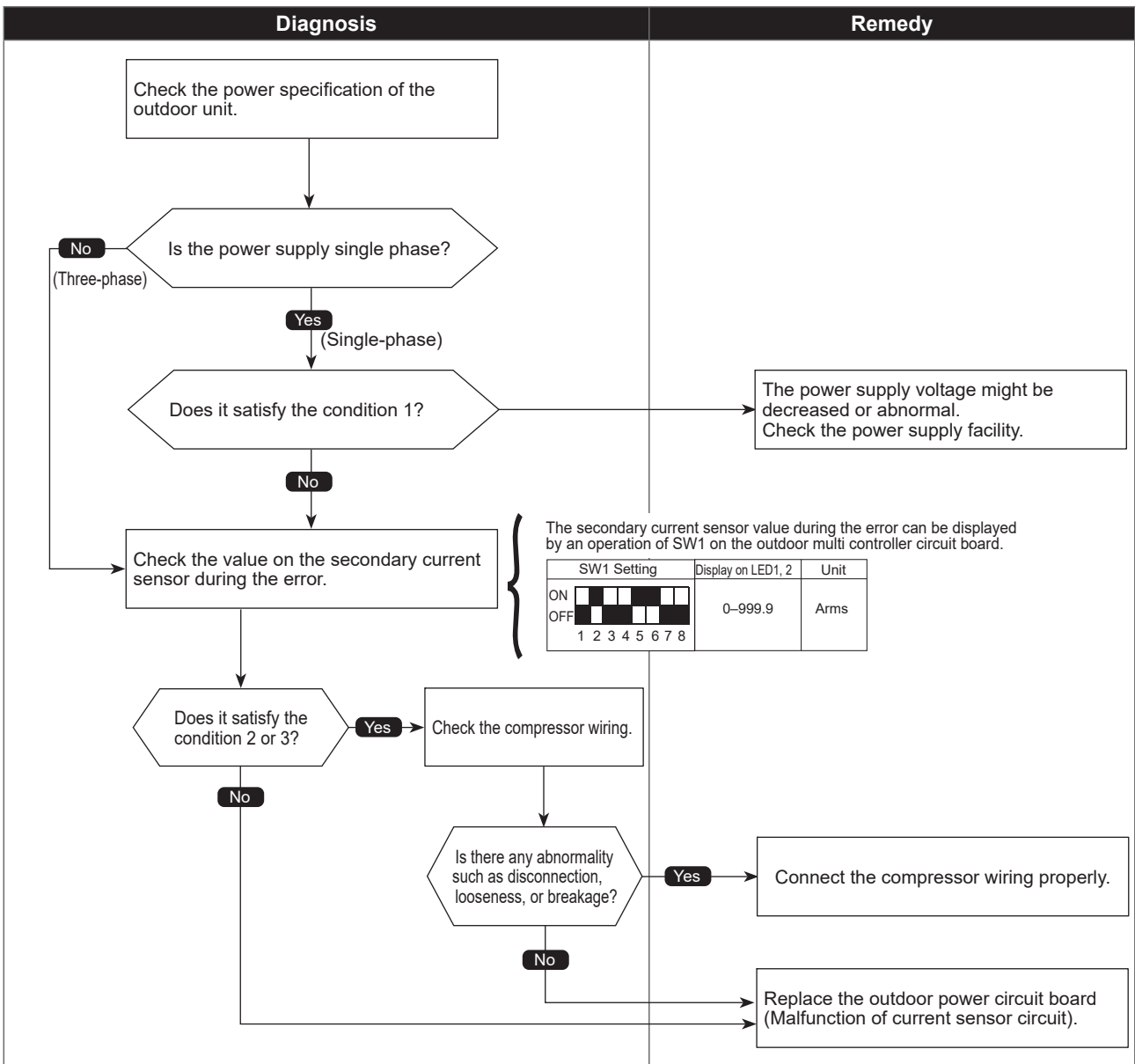

Check code

6600
(A0)

Duplex address error

Abnormal points and detection methods	Causes and checkpoints
If 2 or more units with the same address are existing.	① There are 2 units or more with the same address in their controller among outdoor unit, indoor unit, Fresh Master, Lossnay or remote controller ② Noise interference on indoor/outdoor connectors

●Diagnosis of defects

Make sure to turn the power OFF before connecting/disconnecting any connectors, or replacing boards.

Diagnosis	Remedy
<pre>graph TD; A[Search for a unit with the same address as the source of abnormality.] --> B{Is there any unit with the same address?}; B -- Yes --> C[Correct the address, and turn the power OFF of indoor/outdoor unit, Fresh Master or Lossnay simultaneously for 2 minutes or more, then turn the power back ON.]; B -- No --> D[Turn the power back ON.]; D --> E{Does it operate normally?}; E -- No --> F[Malfunction of sending/receiving circuit on indoor/outdoor unit is suspected.]; E -- Yes --> G[There is no abnormality on the AC unit It might be caused by an external noise, so check the transmission line to remove the factor(s).];</pre>	

Transmission processor hardware error

Abnormal points and detection methods	Causes and checkpoints
<p>If the transmission line shows "1" although the transmission processor transmitted "0".</p>	<ul style="list-style-type: none"> ① A transmitting data collision occurred because of a wiring work or polarity change has performed while the power is ON on either of the indoor/outdoor unit, Fresh Master or Lossnay ② Malfunction of transmitting circuit on transmission processor ③ Noise interference on indoor/outdoor connectors

●Diagnosis of defects

Make sure to turn the power OFF before connecting/disconnecting any connectors, or replacing boards.

Diagnosis	Remedy
<pre> graph TD Q1{{A wiring work was performed while the power OFF.}} Q1 -- No --> R1[If the wiring work was performed while the power ON, turn the power OFF of indoor/outdoor unit, Fresh Master or Lossnay simultaneously for 2 minutes or more, then turn the power back ON.] Q1 -- Yes --> P1[Turn the power back ON.] P1 --> Q2{{Does it operate normally?}} Q2 -- No --> R2[Replace the indoor/outdoor controller board.] Q2 -- Yes --> R3[There is no abnormality on the AC unit. It might be caused by an external noise, so check the transmission line to remove the factor(s).] </pre>	<div data-bbox="965 725 1391 861" style="border: 1px solid black; padding: 5px; margin-bottom: 10px;"> <p>If the wiring work was performed while the power ON, turn the power OFF of indoor/outdoor unit, Fresh Master or Lossnay simultaneously for 2 minutes or more, then turn the power back ON.</p> </div> <div data-bbox="965 1198 1391 1287" style="border: 1px solid black; padding: 5px; margin-bottom: 10px;"> <p>Replace the indoor/outdoor controller board.</p> </div> <div data-bbox="965 1334 1391 1470" style="border: 1px solid black; padding: 5px;"> <p>There is no abnormality on the AC unit. It might be caused by an external noise, so check the transmission line to remove the factor(s).</p> </div>

Transmission bus BUSY error

Abnormal points and detection methods	Causes and checkpoints
<p>① An abnormality when no transmission status caused by transmitting data collision continues for 8 to 10 minutes.</p> <p>② An abnormality when data cannot be output on the transmission line consecutively because of noise etc. for 8 to 10 minutes.</p>	<p>① The transmission processor is unable to transmit due to a short-cycle voltage such as noise is mixed on the transmission line.</p> <p>② The transmission processor is unable to transmit due to an increase of transmission data amount caused by a miswiring of the terminal block (transmission line) (TB3) and the terminal block (centralized control line) (TB7) on the outdoor unit.</p> <p>③ The share on transmission line becomes high due to a mixed transmission caused by a malfunction of repeater on the outdoor unit, which is a function to connect/disconnect transmission from/to control system and centralized control system.</p>

●Diagnosis of defects

Make sure to turn the power OFF before connecting/disconnecting any connectors, or replacing boards.

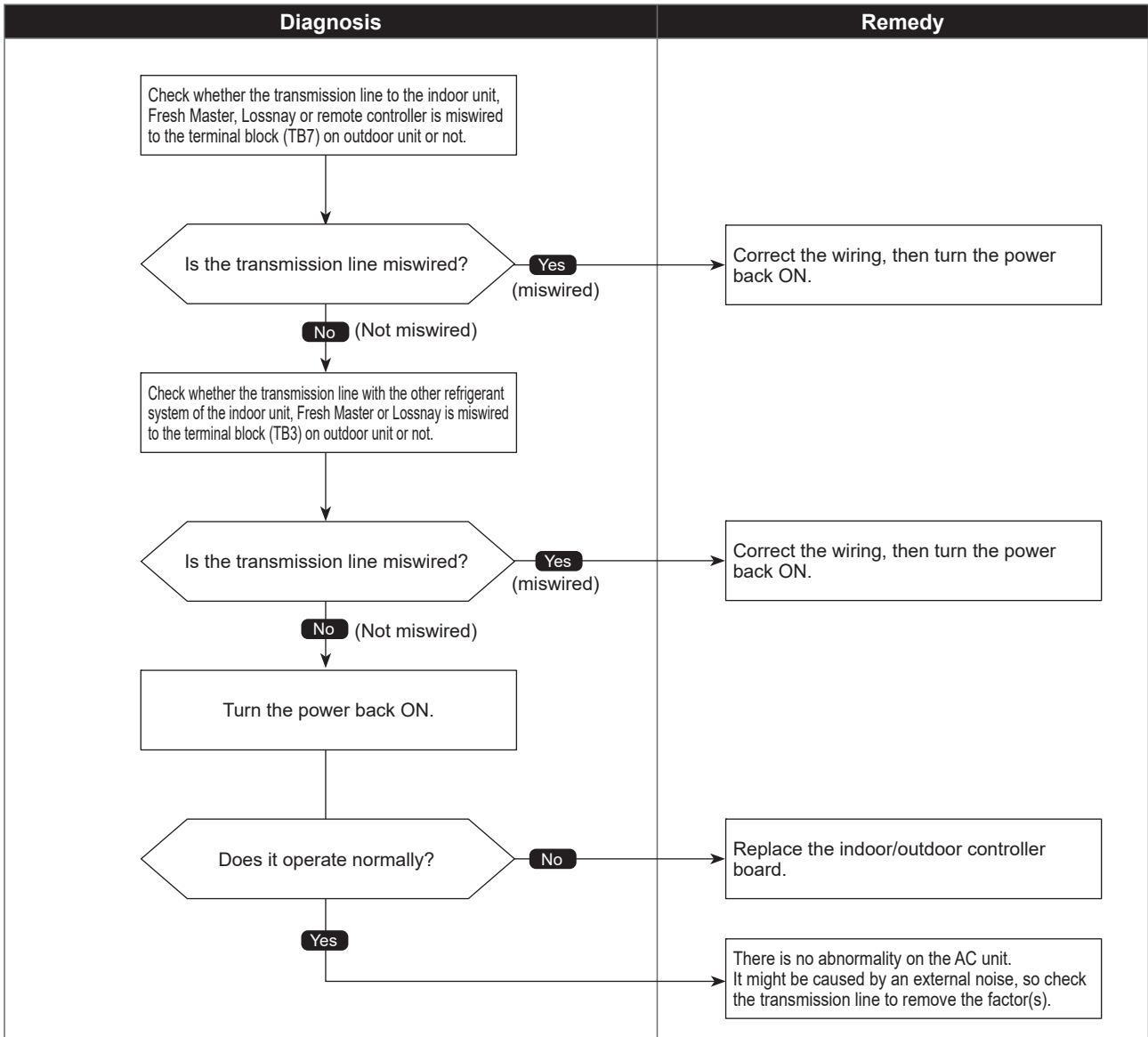

Check code

6606
(A6)

Signal communication error with transmission processor

Abnormal points and detection methods	Causes and checkpoints
<ul style="list-style-type: none">① If the data of unit/transmission processor were not normally transmitted.② If the address transmission from the unit processor was not normally transmitted.	<ul style="list-style-type: none">① Accidental disturbance such as noise or lightning surge② Hardware malfunction of transmission processor

●Diagnosis of defects

Make sure to turn the power OFF before connecting/disconnecting any connectors, or replacing boards.

Diagnosis	Remedy
<p>Turn the power OFF of indoor/outdoor unit, Fresh Master, Lossnay and remote controller simultaneously for 2 minutes or more, then turn the power back ON.</p> <p>Does it operate normally?</p> <p>No</p> <p>Yes</p>	<p>Replace the controller (Defect of error source controller).</p> <p>There is no abnormality on the AC unit. It might be caused by an external noise, so check the transmission line to remove the factor(s).</p>

No ACK error

Abnormal points and detection methods	Causes and checkpoints
<p>① Represents a common error detection An abnormality detected by the sending side controller when receiving no ACK from the receiving side, though signal was once sent. The sending side searches the error in 30 seconds interval for 6 times continuously.</p>	<p>① The previous address unit does not exist since the address switch was changed while in electric continuity status. ② Decline of transmission voltage/signal caused by tolerance over on transmission line ·At the furthest end: 656 ft [200 m] ·On remote controller line: 39 ft [12 m] ③ Decline of transmission voltage/ signal due to unmatched transmission line types ·Types for shield line: CVVS, CPEVS, or MVVS ·Line diameter: AWG 16 [1.25 E] ④ Decline of transmission voltage/ signal due to excessive number of connected units ⑤ Malfunction due to accidental disturbance such as noise or lightning surge ⑥ Defect of error source controller</p>
<p>② The cause of displayed address and attribute is on the outdoor unit side. An abnormality detected by the indoor unit if receiving no ACK when transmitting signal from the indoor unit to the outdoor unit.</p>	<p>① Contact failure of indoor/outdoor unit transmission line ② Disconnection of transmission connector (CN2M) on indoor unit ③ Malfunction of sending/receiving circuit on indoor/outdoor unit ④ Disconnection of the connectors on the circuit board</p>
<p>③ The cause of displayed address and attribute is on the indoor unit side. An abnormality detected by the remote controller if receiving no ACK when sending data from the remote controller to the indoor unit.</p>	<p>① While operating with multi refrigerant system indoor units, an abnormality is detected when the indoor unit transmit signal to the remote controller during the other refrigerant-system outdoor unit is turned OFF, or within 2 minutes after it turned back ON. ② Contact failure of indoor unit or remote controller transmission line ③ Disconnection of transmission connector (CN2M) on indoor unit ④ Malfunction of sending/receiving circuit on indoor unit or remote controller</p>
<p>④ The cause of the displayed address and attribute is on the remote controller side An abnormality detected by the indoor unit if receiving no ACK when transmitting signal from the indoor unit to the remote controller.</p>	<p>① While operating with multi refrigerant system indoor units, an abnormality is detected when the indoor unit transmit signal to the remote controller during the other refrigerant-system outdoor unit is turned OFF, or within 2 minutes after it turned back ON. ② Contact failure of indoor unit or remote controller transmission line ③ Disconnection of transmission connector (CN2M) on indoor unit ④ Malfunction of sending/receiving circuit on indoor unit or remote controller</p>

Abnormal points and detection methods	Causes and checkpoints
<p>⑤ The cause of displayed address and attribute is on the Fresh Master side. An abnormality detected by the indoor unit if receiving no ACK when transmitting signal from the indoor unit to the Fresh Master.</p>	<p>① While the indoor unit is operating with multi refrigerant system Fresh Master, an abnormality is detected when the indoor unit transmits signal to the remote controller while the outdoor unit with the same refrigerant system as the Fresh Master is turned OFF, or within 2 minutes after it turned back ON.</p> <p>② Contact failure of indoor unit or Fresh Master transmission line</p> <p>③ Disconnection of transmission connector (CN2M) on indoor unit or Fresh Master</p> <p>④ Malfunction of sending/receiving circuit on indoor unit or Fresh Master</p>
<p>⑥ The cause of displayed address and attribute is on Lossnay side. An abnormality detected by the indoor unit if receiving no ACK when the indoor unit transmit signal to the Lossnay.</p>	<p>① An abnormality is detected when the indoor unit transmits signal to Lossnay while the Lossnay is turned OFF.</p> <p>② While the indoor unit is operating with the other refrigerant Lossnay, an abnormality is detected when the indoor unit transmits signal to the Lossnay while the outdoor unit with the same refrigerant system as the Lossnay is turned OFF, or within 2 minutes after it turned back ON.</p> <p>③ Contact failure of indoor unit or Lossnay transmission line</p> <p>④ Disconnection of transmission connector (CN2M) on indoor unit</p> <p>⑤ Malfunction of sending/receiving circuit on indoor unit or Lossnay</p>
<p>⑦ The controller of displayed address and attribute is not recognized.</p>	<p>① The previous address unit does not exist since the address switch was changed while in electric continuity status.</p> <p>② An abnormality detected at transmitting from the indoor unit since the Fresh Master/Lossnay address are changed after synchronized setting of Fresh Master/Lossnay by the remote controller.</p>

- Diagnosis of defects
Make sure to turn the power OFF before connecting/disconnecting any connectors, or replacing boards.

Note:

When the address of the outdoor unit is displayed as abnormal, the outdoor circuit board may be faulty. If the unit is not restored after conducting the following procedure, check the outdoor circuit board.

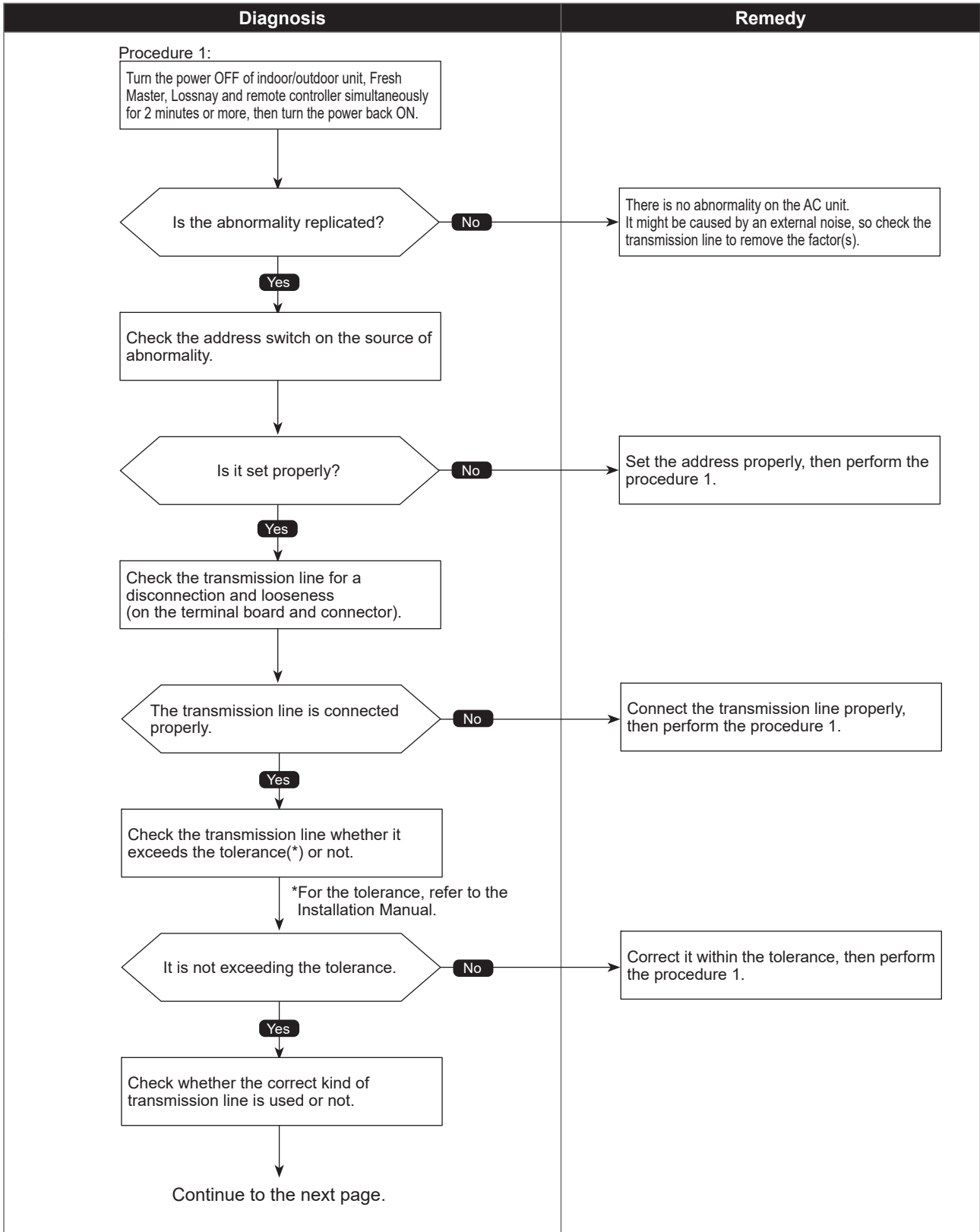

●Diagnosis of defects

Make sure to turn the power OFF before connecting/disconnecting any connectors, or replacing boards.

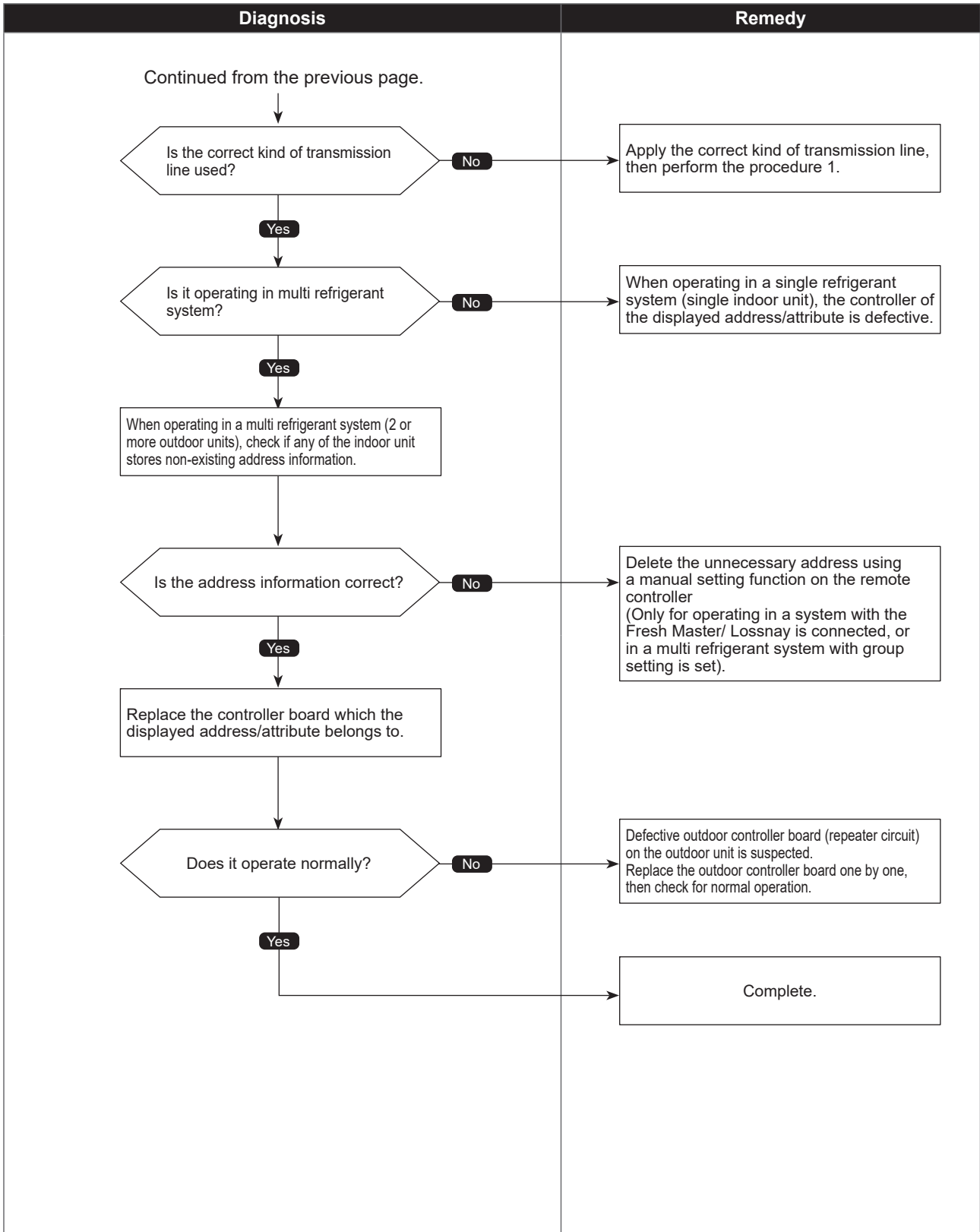

No response frame error

Abnormal points and detection methods	Causes and checkpoints
<p>If receiving no response command while already received ACK. The sending side searches the error in 30 seconds interval for 6 times continuously.</p>	<ul style="list-style-type: none"> ① Continuous failure of transmission due to noise etc ② Decline of transmission voltage/signal caused by tolerance over on transmission line <ul style="list-style-type: none"> ·At the furthest end: 656 ft [200 m] ·On remote controller line: 39 ft [12 m] ③ Decline of transmission voltage/signal due to unmatched transmission line types <ul style="list-style-type: none"> ·Types for shield line: CVVS, CPEVS, or MVVS ·Line diameter: AWG 16 [1.25 E] ④ Accidental malfunction of error source controller

●Diagnosis of defects

Make sure to turn the power OFF before connecting/disconnecting any connectors, or replacing boards.

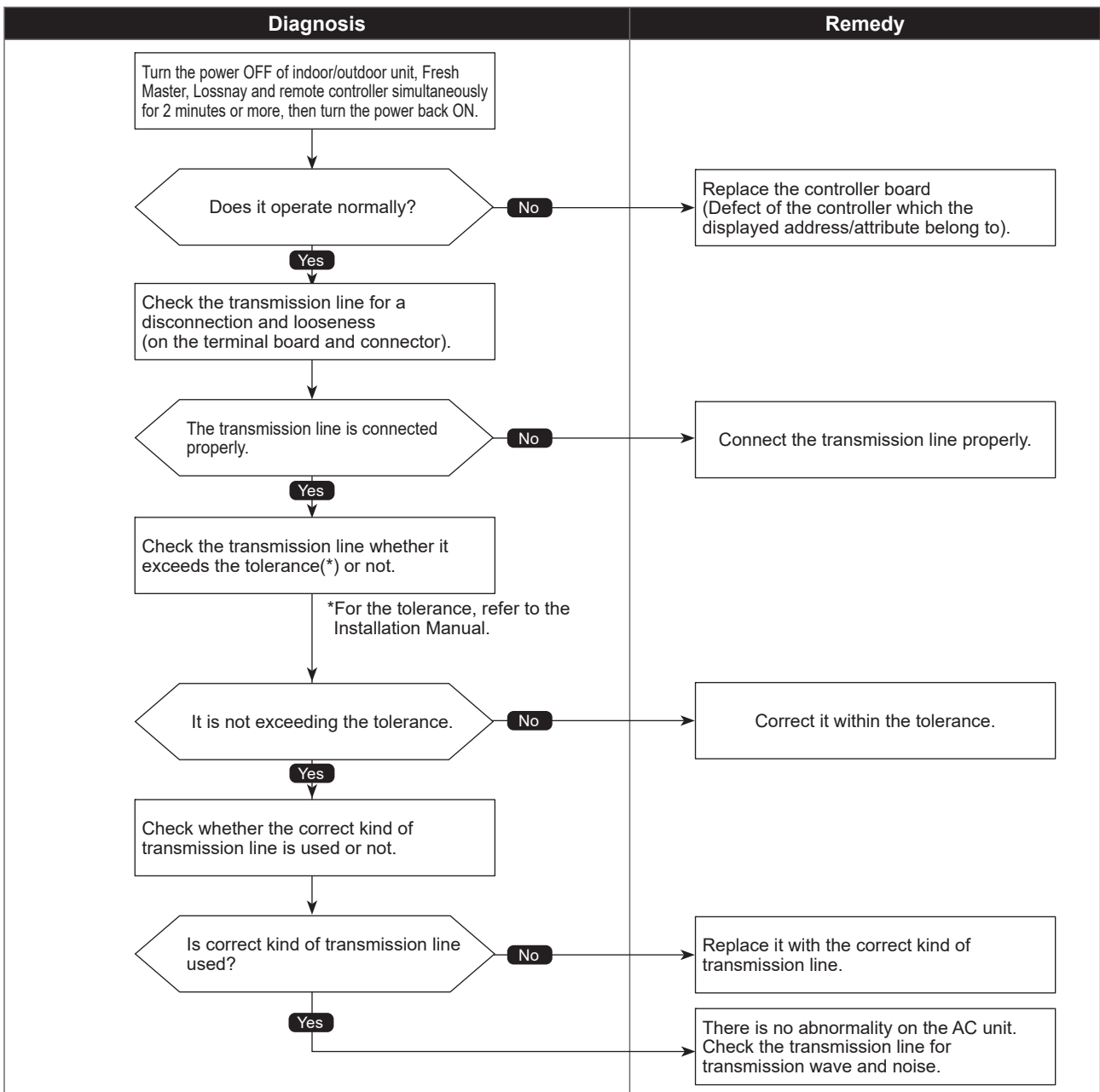

MA communication receive error

Abnormal points and detection methods	Causes and checkpoints
<p>Detected in remote controller or indoor unit:</p> <ul style="list-style-type: none"> ① When the main or sub remote controller cannot receive signal from indoor unit which has the "0" address. ② When the sub remote controller cannot receive signal. ③ When the indoor controller board cannot receive signal from remote controller or another indoor unit. ④ When the indoor controller board cannot receive signal. 	<ul style="list-style-type: none"> ① Contact failure of remote controller wirings ② Irregular Wiring (A wiring length, number of connecting remote controllers or indoor units, or a wiring thickness does not meet the conditions specified in the chapter "Electrical Work" in the indoor unit Installation Manual.) ③ Malfunction of the remote controller sending/receiving circuit on indoor unit with the LED2 is blinking. ④ Malfunction of the remote controller sending/receiving circuit ⑤ Remote controller transmitting error caused by noise interference

●Diagnosis of defects

Make sure to turn the power OFF before connecting/disconnecting any connectors, or replacing boards

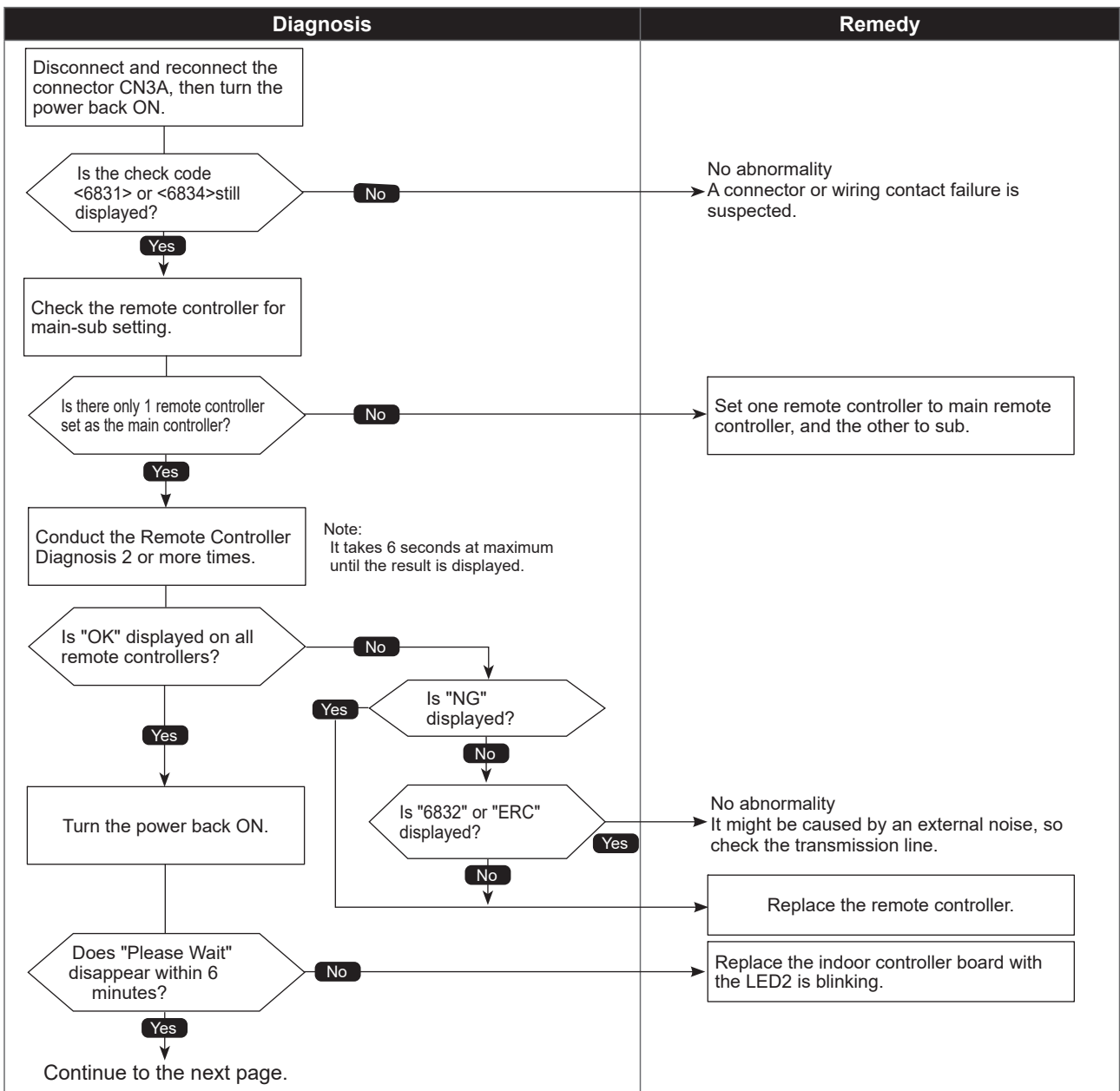

●Diagnosis of defects

Make sure to turn the power OFF before connecting/disconnecting any connectors, or replacing boards

Diagnosis	Remedy
<p>Continued from the previous page.</p> <pre> graph TD Start[Continued from the previous page.] --> Step1[Refer to the chapter "Electrical Work".] Step1 --> Decision{Is the wiring connected properly, meeting the condition?} Decision -- No --> Remedy1[Connect the wiring properly as specified in the chapter "Electrical Work" in the indoor unit Installation Manual.] Decision -- Yes --> Remedy2[No abnormality It might be caused by an external noise, so check the transmission line to remove the factor(s).] </pre>	<div data-bbox="970 689 1394 778" style="border: 1px solid black; padding: 5px;"> <p>Connect the wiring properly as specified in the chapter "Electrical Work" in the indoor unit Installation Manual.</p> </div> <p>No abnormality It might be caused by an external noise, so check the transmission line to remove the factor(s).</p>

Abnormal points and detection methods	Causes and checkpoints
Detected in remote controller or indoor unit.	<ul style="list-style-type: none"> ① There are 2 remote controllers set as main. ② Malfunction of remote controller sending/receiving circuit ③ Malfunction of sending/receiving circuit on indoor controller board ④ Remote controller transmitting error caused by noise interference

●Diagnosis of defects

Make sure to turn the power OFF before connecting/disconnecting any connectors, or replacing boards

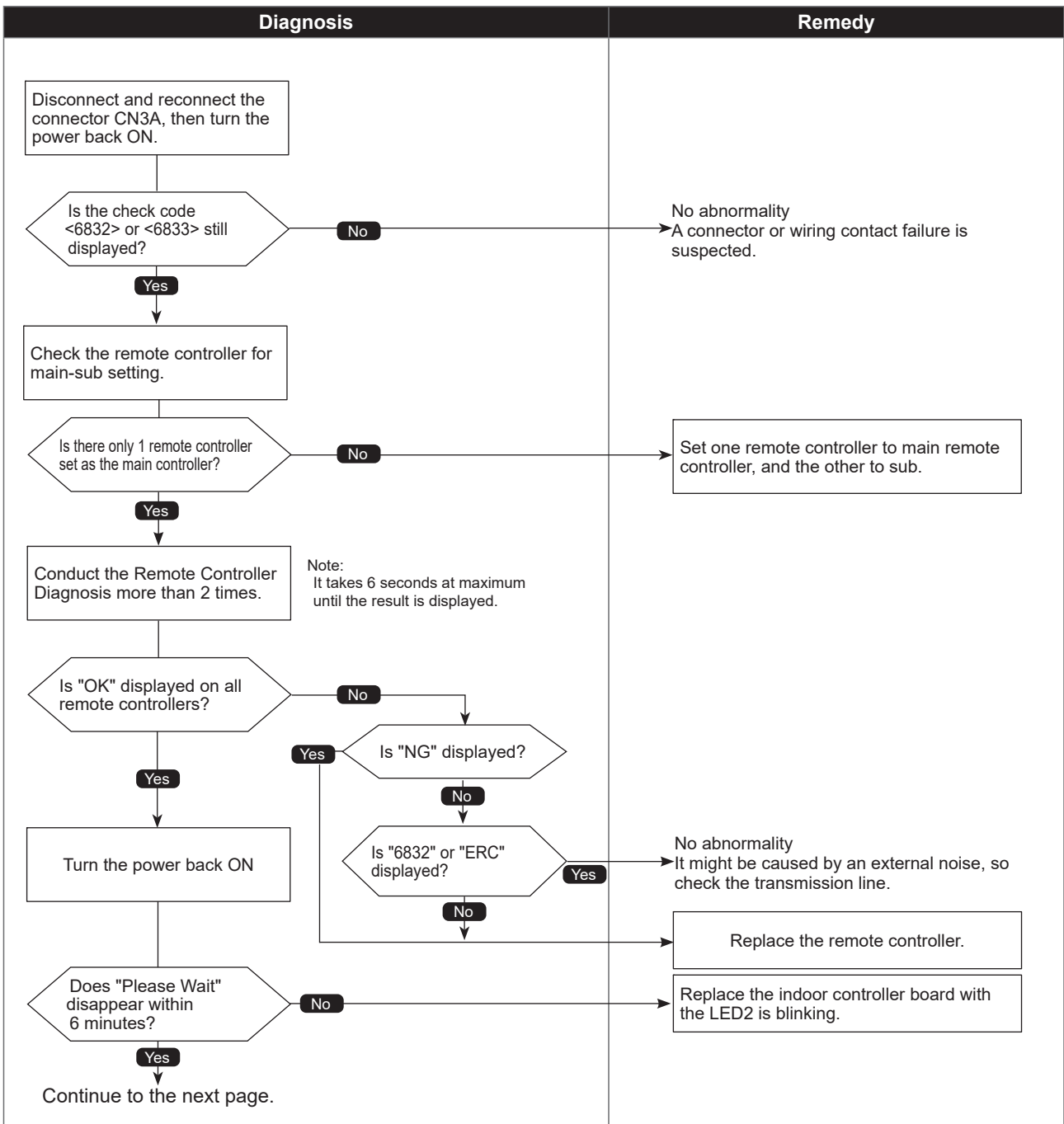

●Diagnosis of defects

Make sure to turn the power OFF before connecting/disconnecting any connectors, or replacing boards

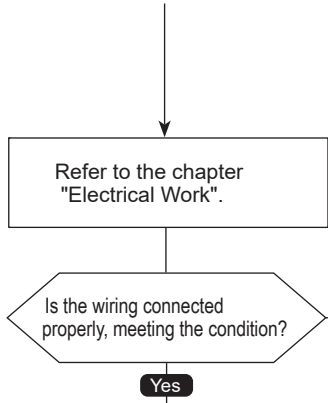
Diagnosis	Remedy
<p>Continued from the previous page.</p>  <pre> graph TD Start[Continued from the previous page.] --> Refer[Refer to the chapter "Electrical Work".] Refer --> Decision{Is the wiring connected properly, meeting the condition?} Decision -- No --> Remedy1[Connect the wiring properly as specified in the chapter "Electrical Work" in the indoor unit Installation Manual.] Decision -- Yes --> Remedy2[No abnormality. It might be caused by an external noise, so check the transmission line to remove the factor(s).] </pre>	<p>Connect the wiring properly as specified in the chapter "Electrical Work" in the indoor unit Installation Manual.</p> <p>No abnormality It might be caused by an external noise, so check the transmission line to remove the factor(s).</p>

Check code

7100
(EF)

Total capacity error

Abnormal points and detection methods	Causes and checkpoints
<p>When the total capacity of connected indoor units exceeds the specified capacity (130% of the outdoor unit capacity), a check code <7100> is displayed.</p>	<p>① The total capacity of connected indoor units exceeds the specified capacity (without Branch Box / with Branch Box).</p> <ul style="list-style-type: none"> · SM36: up to code 32/29 · SM42: up to code 35/35 · SM48: up to code 43/40 · SM60: up to code 56/53 <p>② The model name code of the outdoor unit is registered wrongly.</p>

●Diagnosis of defects

Make sure to turn the power OFF before connecting/disconnecting any connectors, or replacing boards.

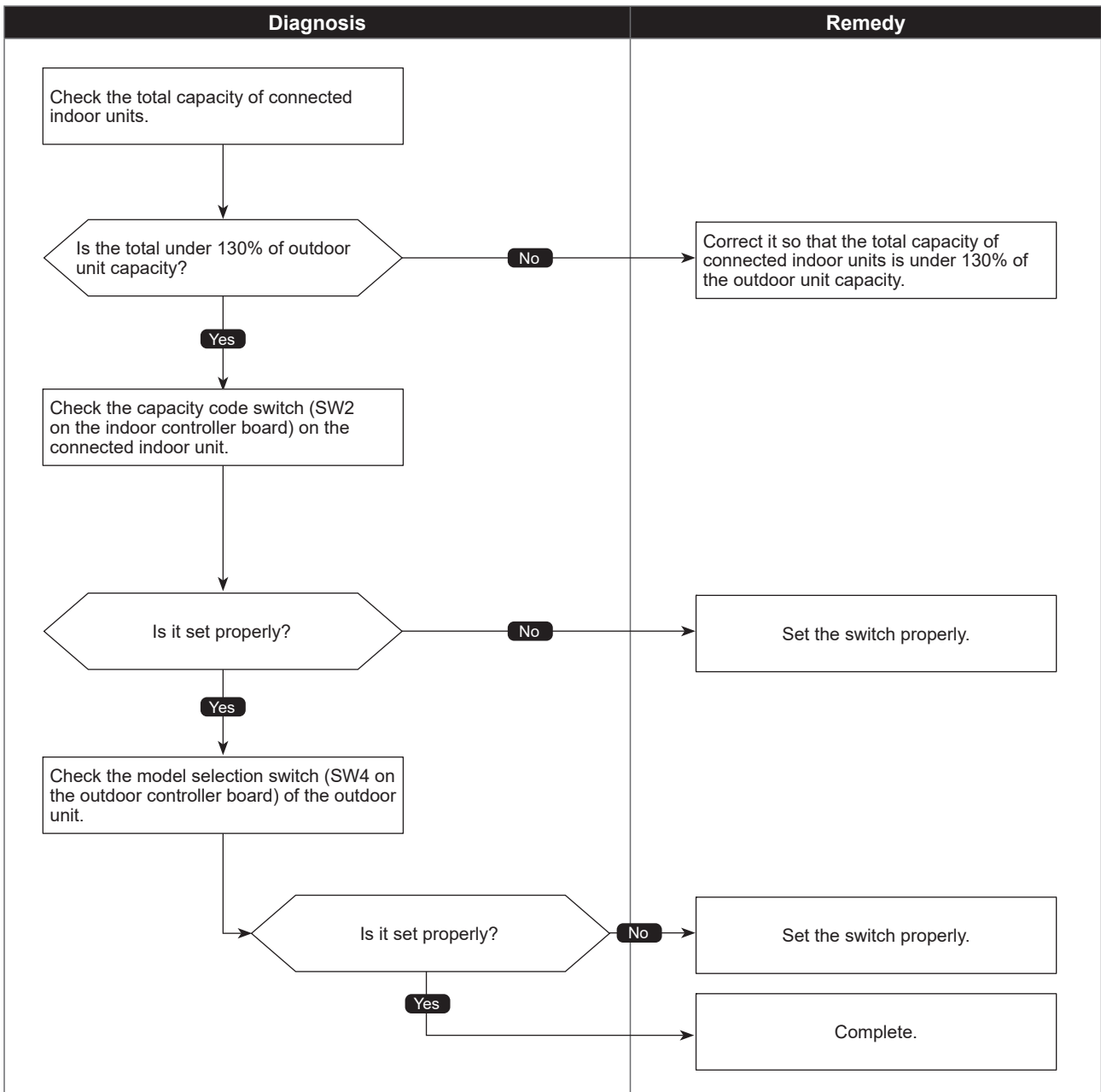

Check code

7101
(EF)

Capacity code error

Abnormal points and detection methods

When the capacity of connected indoor unit is over, check code <7101> is displayed.

Causes and checkpoints

The model name of connected indoor unit (model code) is read as incompatible.

●Diagnosis of defects

Make sure to turn the power OFF before connecting/disconnecting any connectors, or replacing boards.

Diagnosis

Check the model selection switch (SW4 on the indoor controller board) of the connected indoor unit.

Is it set properly?

No

Yes

Remedy

Set the switch properly.

The model code of the connected indoor unit can be displayed by an operation of SW1 on the outdoor unit.

Connecting excessive number of units and branch boxes

Abnormal points and detection methods	Causes and checkpoints
When the connected indoor units exceed the limit, a check code <7102> is displayed.	Connecting more indoor units than the limit. Abnormal if connecting status does not comply with the following limit; ① Maximum connectable indoor unit. ② Connect at least 1 indoor unit (Abnormal if connected none). ③ Connectable up to 2 branch boxes.

●Diagnosis of defects

Make sure to turn the power OFF before connecting/disconnecting any connectors, or replacing boards.

Diagnosis	Remedy
<pre> graph TD A[Check whether the connecting unit exceeds the limit or not.] --> B{Does it exceed the limit?} B -- Yes --> C[Connect less number of units than the limit.] B -- No --> D[Check if at least 1 indoor unit is connected.] D --> E{Is an indoor unit connected?} E -- No --> F[Connect indoor unit.] E -- Yes --> G[Check whether the M-NET line to the indoor unit is connected or not.] </pre>	<div data-bbox="967 1157 1390 1247" style="border: 1px solid black; padding: 5px; margin-bottom: 10px;">Connect less number of units than the limit.</div> <div data-bbox="967 1278 1390 1368" style="border: 1px solid black; padding: 5px; margin-bottom: 10px;">The model code of the connected indoor unit can be displayed by an operation of SW1 on the outdoor unit.</div> <div data-bbox="967 1655 1390 1744" style="border: 1px solid black; padding: 5px; margin-bottom: 10px;">Connect indoor unit.</div> <div data-bbox="967 1796 1390 1885" style="border: 1px solid black; padding: 5px;">Check whether the M-NET line to the indoor unit is connected or not.</div>

Address setting error

Abnormal points and detection methods	Causes and checkpoints
The address setting of outdoor unit or branch box is wrong.	Wrongly set address of branch box The outdoor unit is not set in 000, or in the range of 51 to 100.

●Diagnosis of defects

Make sure to turn the power OFF before connecting/disconnecting any connectors, or replacing boards.

Diagnosis	Remedy
<p><Outdoor unit></p> <p>Check whether the outdoor unit address is set in 000, or in the range of 51 to 100.</p> <p>Is the address setting correct?</p> <p>Yes</p> <p>No</p>	<p>Set the address properly, then turn the power OFF of indoor/outdoor unit, Fresh Master, Lossnay and remote controller simultaneously for 2 minutes or more, and turn the power back ON.</p> <p>Replace the outdoor controller board.</p>
<p><Branch box></p> <p>Check whether the branch box address is set in 000, or in the range of 001 to 050.</p> <p>Is the address setting correct?</p> <p>Yes</p> <p>No</p>	<p>Set the address properly, then turn the power OFF of indoor/outdoor unit, branch box, Fresh Master, Lossnay, and remote controller simultaneously for 2 minutes or more, and turn the power back ON.</p> <p>Replace the branch box controller board.</p>
<p>Note: Branch box address When setting the address, use a number within the range of 1–50. Ex. The set address is (47) and there are 5 indoor units (A, B, C, D, and E). If A: (47), B: (48), C: (49), D: (50), and E: (51), E is incorrect because it exceeds 50.</p>	

Check code

7130
(EF)

Incompatible unit combination error

Abnormal points and detection methods

When the connected indoor unit is not compatible with the outdoor unit, the outdoor unit detects the error at startup.

Causes and checkpoints

Connecting indoor unit(s) which is not authorized to connect to the outdoor unit.

●Diagnosis of defects

Make sure to turn the power OFF before connecting/disconnecting any connectors, or replacing boards.

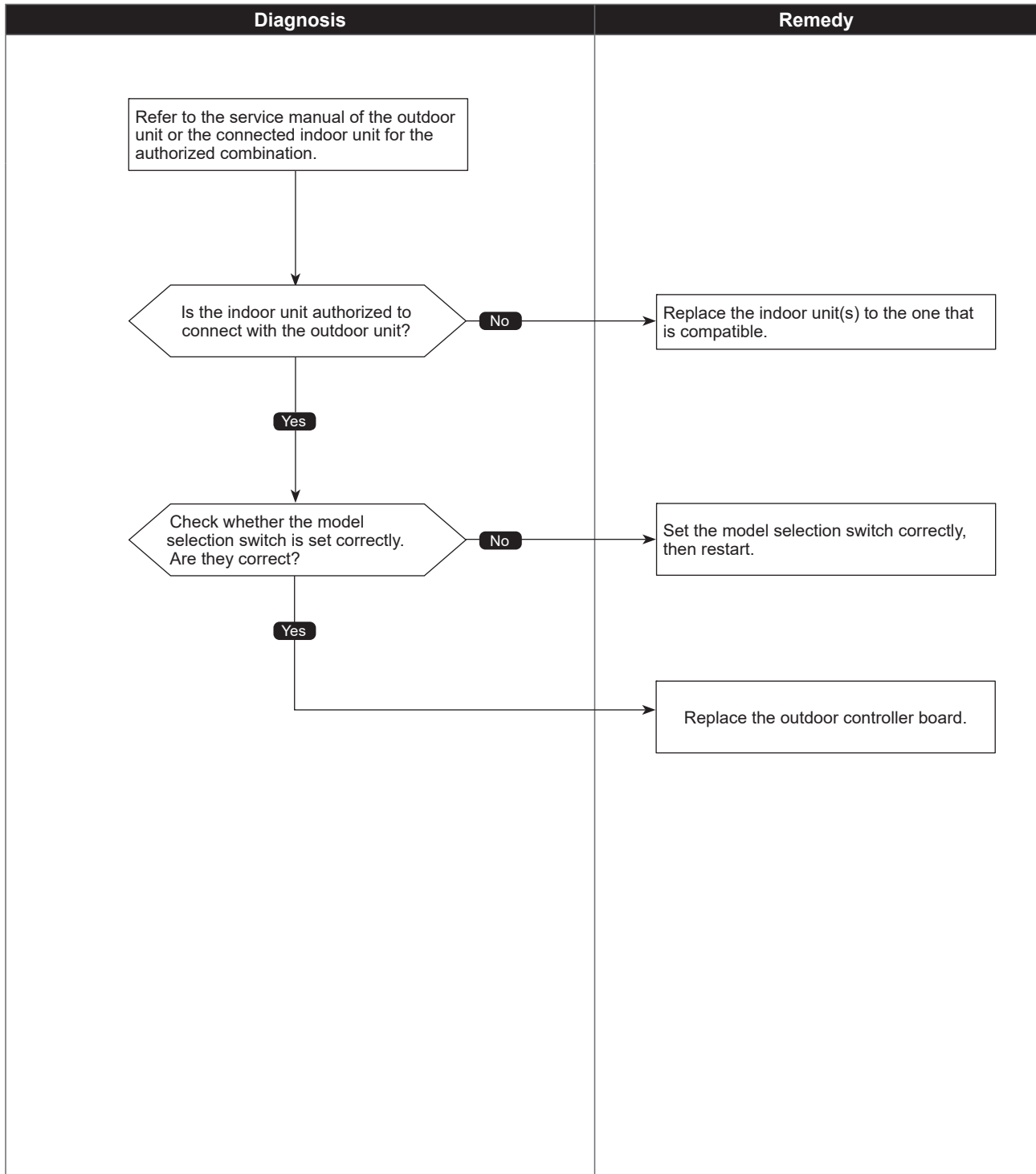

8-2. REMOTE CONTROLLER DIAGNOSIS

For the detailed procedure, refer to the remote controller's manuals.

8-3. REMOTE CONTROLLER TROUBLE

For the troubleshooting, refer to the remote controller's manuals.

8-4. THE FOLLOWING SYMPTOM DO NOT REPRESENT TROUBLE (EMERGENCY)

Symptom	Display of remote controller	CAUSE
Even the cooling (heating) operation selection button is pressed, the indoor unit cannot be operated.	"Cool (Heat)" blinks	The indoor unit cannot cool (Heat) if other indoor units are heating (Cooling).
The auto vane runs freely.	Normal display	Because of the control operation of auto vane, it may change over to horizontal blow automatically from the downward blow in cooling because the downward blow operation has been continued for 1 hour. At defrosting in heating, hot adjusting and thermostat OFF, it automatically changes over to horizontal blow.
Fan setting changes during heating.	Normal display	Ultra-low speed operation is commenced at thermostat OFF. Light air automatically change over to set value by time or piping temperature at thermostat ON.
Fan stops during heating operation.	"Heat Defrost ☼ "	The fan stops during defrosting.
Fan does not stop while operation has been stopped.	Light out	Fan runs for 1 minute after stopping to exhaust residual heat (only in heating).
No setting of fan while start SW has been turned on.	"Heat Standby ☼ "	Ultra-low speed operation for 5 minutes after SW ON or until piping temperature reaches 95°F [35°C]. Then low speed operates for 2 minutes and operates at the normal set air volume. (Hot adjust control)
Indoor unit remote controller shows "Please Wait" indicator for about 2 minutes when turning ON power supply.	"Please Wait" blinks	The system is in the process of startup. Operate remote controller again after "Please Wait" disappears.
Drain pump does not stop while unit has been stopped.	Light out	After a stop of cooling operation, unit continues to operate drain pump for 3 minutes and then stops.
Drain pump continues to operate while unit has been stopped.	—	Unit continues to operate drain pump if drainage is generated, even during a stop.

8-5. INTERNAL SWITCH FUNCTION TABLE

The black square (■) indicates a switch position.

Switch	Step	Function	Operation in Each Switch Setting		Remarks	Purpose	Additional Information
			ON	OFF			
SWU1 ones digit SWU2 tens digit	Rotary switch		Before turning the power ON		<Initial settings> 	—	—
	1-8		Can be set either during operation or not.		<Initial settings> 	—	—
SW2 Function Switch	1	Selects operating system startup	With centralized controller	Without centralized controller	<Initial settings> 	Turn ON when the centralized controller is connected to the outdoor unit.	SW2-1 must be turned ON if a central controller is connected to the system. An example of this would be a TC-24, EW-50A, AG-150, AE50 or AE200. If SW2-1 is not turned on, while using a central controller, in rare circumstances problems may be encountered such as indoor units not responding to group commands. Therefore, turning SW2-1 ON is recommended if a central controller is used.
		2	Connection Information Clear Switch	Clear	Do not clear	When relocating units or connecting additional units.	When relocating units or connecting additional units.
	3	Abnormal data clear switch input	Clear abnormal data	Normal	To delete an error history.	To delete an error history.	
	4	Pump down	ON	OFF	To facilitate outdoor unit the pumping down operation. Frequency = Fixed to 65 Hz Indoor-linear expansion valve = Fully open Outdoor fan step = Fixed to 10	Please refer to a section referring to the pumping down on outdoor units Installation Manuals. It might not be possible to collect all the refrigerant if the amount is excessive.	
	5	Connect branch box	Connect	Not connect	<Initial settings> OFF	—	
	6	MODEL SELECTION 1:ON 0:OFF	—	—	—	—	
SW4/ SW8/ (SW9) Model Switch	1-6	MODELS SW2 SW4 SW6 SW8 MAZ-SMBNAM ON OFF ON OFF ON OFF ON OFF	MODELS SW2 SW4 SW6 SW8 MAZ-SMBNAM ON OFF ON OFF ON OFF ON OFF	MODELS SW2 SW4 SW6 SW8 MAZ-SMBNAM ON OFF ON OFF ON OFF ON OFF	<Initial settings> Set for each capacity.	—	—
		MODELS SW2 SW4 SW6 SW8 MAZ-SMBNAM ON OFF ON OFF ON OFF ON OFF	MODELS SW2 SW4 SW6 SW8 MAZ-SMBNAM ON OFF ON OFF ON OFF ON OFF	MODELS SW2 SW4 SW6 SW8 MAZ-SMBNAM ON OFF ON OFF ON OFF ON OFF	<Initial settings> Set for each capacity.	—	—
SW3 Trial operation	1	ON/OFF from outdoor unit	ON	OFF	<Initial settings> ON OFF	—	—
	2	Mode setting	Heating	Cooling	—	—	—
SW5 Function switch	1	Change the indoor unit's LEV opening at startup	Enable	Normal	—	To set the LEV opening at startup higher than usual. (+150 pulses) To improve the operation with the LEV almost clogged.	The refrigerant flow noise at startup become louder.
	2	Auxiliary heater	Enable	Disable	<Initial settings> 	Turn ON when an auxiliary heater is connected. (It transmits a connection permission signal of the auxiliary heater to the connected CITY MULTI indoor unit).	Turn ON only when the auxiliary heater is connected and operated.
	3	Change the indoor unit's LEV opening at defrost	Enable	Normal	—	To set the LEV opening higher than usual during defrosting operation. (Only Q1 [10] is valid. + 300 pulses) To avoid the discharge temperature increase and provide efficient defrosting operation.	The refrigerant flow noise during the defrosting operation becomes louder.
	4	Switching the target sub cool (Heating mode)	Enable	Normal	—	To decrease the target sub cool value. To reduce the discharge temperature decrease due to refrigerant liquid accumulation in the units.	A refrigerant flow noise might be generated if the sub cool value is too small.
	5	Change the indoor unit's LEV opening at defrost	Enable	Normal	—	—	—
	6	Switching the target sub cool (Heating mode)	Enable	Normal	—	—	—



Switch	Step	Function	Operation in Each Switch Setting		When to Set	Remarks	Purpose	Additional Information	
			ON	OFF					
SW5 Function switch	7	During the outdoor unit is in HEAT operation, additionally increase about 50 to 70 pulses of the LEV opening on the indoor unit which is in FAN, STOP, COOL or thermo-OFF*1.	Active	Inactive	Can be set when OFF or during operation	<Initial settings> ON <input type="checkbox"/> 1 <input type="checkbox"/> 2 <input type="checkbox"/> 3 <input type="checkbox"/> 4 <input type="checkbox"/> 5 <input type="checkbox"/> 6 <input type="checkbox"/> 7 <input type="checkbox"/> 8 OFF <input checked="" type="checkbox"/> 1 <input checked="" type="checkbox"/> 2 <input checked="" type="checkbox"/> 3 <input checked="" type="checkbox"/> 4 <input checked="" type="checkbox"/> 5 <input checked="" type="checkbox"/> 6 <input checked="" type="checkbox"/> 7 <input checked="" type="checkbox"/> 8	To additionally increase about 50 to 70 pulses of the LEV opening for units other than in HEAT operation. To avoid a refrigerant shortage (less capacity) due to refrigerant liquid accumulation in the units which is not in operation.	A refrigerant flow noise might be generated in units other than the one in operation.	
			Enable	Normal	Before turning the power ON.		To reduce the room temperature increase by setting the LEV opening lower for the units in thermo-OFF operation.	The refrigerant is more likely to collect in the units with thermo-OFF operation, and causing the units refrigerant shortage. (Results in less capacity and increase of discharge temperature.)	
	SW6 Function switch	1							
		2							
		3							
		4	Change of defrosting control	Enable (For high humidity)	Normal		<Initial settings> ON <input type="checkbox"/> 1 <input type="checkbox"/> 2 <input type="checkbox"/> 3 <input type="checkbox"/> 4 <input type="checkbox"/> 5 <input type="checkbox"/> 6 <input type="checkbox"/> 7 <input type="checkbox"/> 8 OFF <input checked="" type="checkbox"/> 1 <input checked="" type="checkbox"/> 2 <input checked="" type="checkbox"/> 3 <input checked="" type="checkbox"/> 4 <input checked="" type="checkbox"/> 5 <input checked="" type="checkbox"/> 6 <input checked="" type="checkbox"/> 7 <input checked="" type="checkbox"/> 8	To shorten the defrosting prohibition time in high humidity (or heavy snow) region, in order to reduce malfunctions caused by frost.	The performance of the HEAT operation is somewhat reduced since the defrosting operation is frequently performed.
		5			Can be set when OFF or during operation				
		6	Switching the target discharge pressure (Pdm)	Enable	Normal		SW6-6 Target Pdm (kg/cm ²) OFF <input type="checkbox"/> 1 <input type="checkbox"/> 2 <input type="checkbox"/> 3 <input type="checkbox"/> 4 <input type="checkbox"/> 5 <input type="checkbox"/> 6 <input type="checkbox"/> 7 <input type="checkbox"/> 8 ON <input checked="" type="checkbox"/> 1 <input checked="" type="checkbox"/> 2 <input checked="" type="checkbox"/> 3 <input checked="" type="checkbox"/> 4 <input checked="" type="checkbox"/> 5 <input checked="" type="checkbox"/> 6 <input checked="" type="checkbox"/> 7 <input checked="" type="checkbox"/> 8	To raise the performance by setting the Pdm higher during HEAT operation.	Power consumption is raised due to a higher frequency. (The performance would not be raised at the maximum operating frequency.)
SW7 Function switch	7	Switching (1) the target evaporation temperature (ETm)	Enable	Normal		SW6-7 Target ETm (°F/C) OFF <input type="checkbox"/> 1 <input type="checkbox"/> 2 <input type="checkbox"/> 3 <input type="checkbox"/> 4 <input type="checkbox"/> 5 <input type="checkbox"/> 6 <input type="checkbox"/> 7 <input type="checkbox"/> 8 ON <input checked="" type="checkbox"/> 1 <input checked="" type="checkbox"/> 2 <input checked="" type="checkbox"/> 3 <input checked="" type="checkbox"/> 4 <input checked="" type="checkbox"/> 5 <input checked="" type="checkbox"/> 6 <input checked="" type="checkbox"/> 7 <input checked="" type="checkbox"/> 8	To raise/reduce the performance by changing the target ETm during COOL operation.	Switching it to raise the performance, it raises the power consumption, and produces more dew condensation.	
	8	Switching (2) the target evaporation temperature (ETm)	Enable	Normal		SW6-8 Target ETm (°F/C) OFF <input type="checkbox"/> 1 <input type="checkbox"/> 2 <input type="checkbox"/> 3 <input type="checkbox"/> 4 <input type="checkbox"/> 5 <input type="checkbox"/> 6 <input type="checkbox"/> 7 <input type="checkbox"/> 8 ON <input checked="" type="checkbox"/> 1 <input checked="" type="checkbox"/> 2 <input checked="" type="checkbox"/> 3 <input checked="" type="checkbox"/> 4 <input checked="" type="checkbox"/> 5 <input checked="" type="checkbox"/> 6 <input checked="" type="checkbox"/> 7 <input checked="" type="checkbox"/> 8	Switch to raise the performance: raises the performance Switch to reduce the performance: prevents dew condensation	Switching it to reduce the performance, it makes the performance insufficient.	
	1	Ignore current sensor abnormality and rotational frequency abnormality of outdoor fan motor	Enable	Normal	After turning the power ON			Make sure to connect the connectors to the compressor after checking the electrical parts. Be careful not to get electrical shock while working on electrical parts.	
	2	Setting to energize the freeze stat heater (optional part)	During heating operation only*3	Include when the heating operation is OFF.*4	Can be set when OFF or during operation	<Initial settings> ON <input type="checkbox"/> 1 <input type="checkbox"/> 2 <input type="checkbox"/> 3 <input type="checkbox"/> 4 <input type="checkbox"/> 5 <input type="checkbox"/> 6 OFF <input checked="" type="checkbox"/> 1 <input checked="" type="checkbox"/> 2 <input checked="" type="checkbox"/> 3 <input checked="" type="checkbox"/> 4 <input checked="" type="checkbox"/> 5 <input checked="" type="checkbox"/> 6	It reduces snow on the base, even it blows inside the unit, by setting the base heater ON while the HEAT operation is stopped.	Power consumption raises while the operation is stopped.	
	3	High heating performance mode (except for NAMHZ model)	Enable	Normal	Anytime			The performance may not be raised depending on the capacity of indoor units in operation, or outside air temperature.	
	4	Maximum frequency down at 1 hour after COOL operation	Enable	Normal	Can be set when OFF or during operation			The performance might be insufficient.	
	5	Simultaneous cooling and heating with external heater	Enable	Disable	Anytime			For the installation of external heater and the indoor unit setting, refer to the indoor unit service manual.	
	6	Manual defrost	Manual defrost	Normal	During compressor running in HEAT mode.			It forms the defrosting operation forcibly. (HEAT operation is stopped temporarily.)	
SW9 Function Switch	1	Auto change over from remote controller (IC with the minimum address)	Enable	Disable	Before turning the power ON	<Initial settings> ON <input type="checkbox"/> 1 <input type="checkbox"/> 2 <input type="checkbox"/> 3 <input type="checkbox"/> 4 OFF <input checked="" type="checkbox"/> 1 <input checked="" type="checkbox"/> 2 <input checked="" type="checkbox"/> 3 <input checked="" type="checkbox"/> 4	Enables the indoor unit with the minimum address to select AUTO mode, and switches the operation mode of the other indoor units to the same mode.	Cannot be set when the centralized control is ON.	
	2	Switching the Silent/Demand mode	Demand control	Silent mode	Can be set when OFF or during operation			About the Silent mode/Demand control setting, refer to "8-6. OUTDOOR UNIT INPUT/OUTPUT CONNECTOR".	
	3								
	4								

*1 SW5-7 Opens the indoor-linear expansion valve as a countermeasure against the indoor unit in FAN, COOL, STOP, or thermo-OFF operation with refrigerant-shortage status due to an accumulation of liquid refrigerant in the indoor unit.

*2 SW5-8 Countermeasure against room temperature rise for indoor unit in FAN and COOL mode.

*3 During heating operation and the ambient temperature is 39°F (4°C) or below, the freeze prevention heater is energized.

*4 During heating mode is OFF (include thermo-OFF in cooling mode), and the ambient temperature is 39°F (4°C) or below, the freeze prevention heater is energized.

*5 Use it for Model Switch. (H)P36/48

8-6. OUTDOOR UNIT INPUT/OUTPUT CONNECTOR

• State (CN51)

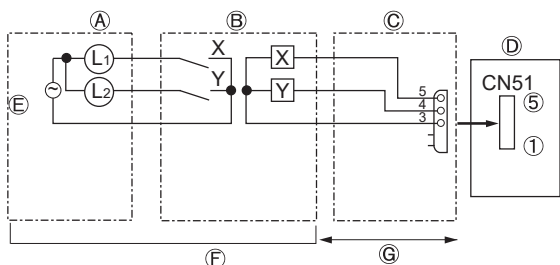

- Ⓐ Distant control board
- Ⓑ Relay circuit
- Ⓒ External output adapter (PAC-SA88HA-E)
- Ⓓ Outdoor unit control board

- Ⓔ Lamp power supply
- Ⓕ Procure locally
- Ⓖ Max. 33 ft [10 m]

L1: Error display lamp
 L2: Compressor operation lamp
 X, Y: Relay (coil rating: ≤ 0.9 W, 12 V DC)

• Auto change over (CN3N)

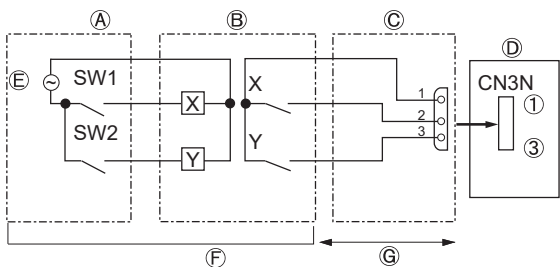

- Ⓐ Remote control panel
- Ⓑ Relay circuit
- Ⓒ External input adapter (PAC-SC36NA-E)
- Ⓓ Outdoor unit control board

- Ⓔ Relay power supply
- Ⓕ Procure locally
- Ⓖ Max. 33 ft [10 m]

SW1: Switch
 SW2: Switch
 X, Y: Relay (contact rating: ≥ 0.1 A, 15 V DC)
 (min. applicable load: ≤ 1 mA)

	ON	OFF
SW1	Heating	Cooling
SW2	Validity of SW1	Invalidity of SW1

• Silent Mode/Demand Control (CN3D)

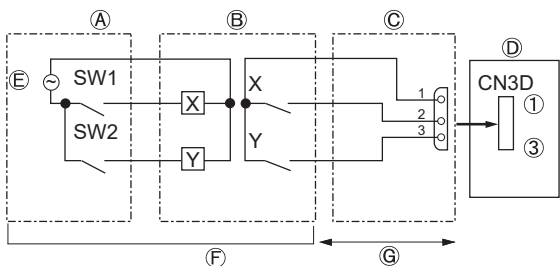

- Ⓐ Remote control panel
- Ⓑ Relay circuit
- Ⓒ External input adapter (PAC-SC36NA-E)
- Ⓓ Outdoor unit control board

- Ⓔ Relay power supply
- Ⓕ Procure locally
- Ⓖ Max. 33 ft [10 m]

SW1: Switch
 SW2: Switch
 X, Y: Relay (contact rating: ≥ 0.1 A, 15 V DC)
 (min. applicable load: ≤ 1 mA)

The silent mode and the demand control are selected by switching the DIP switch 9-2 on outdoor controller board. It is possible to set it to the following power consumption (compared with ratings) by setting SW1, 2.

	Outdoor controller board DIP SW9-2	SW1	SW2	Function
Silent mode	OFF	ON	—	Silent mode operation
Demand control	ON	OFF	OFF	100% (Normal)
		ON	OFF	75%
		ON	ON	50%
		OFF	ON	0% (Stop)

8-7. HOW TO CHECK PARTS

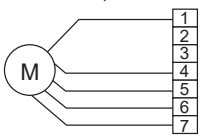
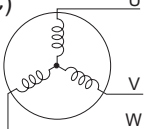
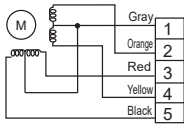
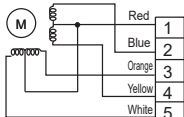
Parts name	Checkpoints																					
Thermistor (TH2) <Hic pipe> Thermistor (TH3) <Outdoor liquid pipe> Thermistor (TH4) <Compressor> Thermistor (TH6) <Suction pipe> Thermistor (TH7) <Ambient> Thermistor (TH8) <Heat sink>	Disconnect the connector then measure the resistance with a multimeter. (At the ambient temperature 50 to 80°F [10 to 30°C]) <table border="1" style="margin-top: 10px;"> <thead> <tr> <th></th> <th>Normal</th> <th>Abnormal</th> </tr> </thead> <tbody> <tr> <td>TH4</td> <td>160 to 410 kΩ</td> <td rowspan="4">Open or short</td> </tr> <tr> <td>TH2</td> <td rowspan="3">4.3 to 9.6 kΩ</td> </tr> <tr> <td>TH3</td> </tr> <tr> <td>TH6</td> </tr> <tr> <td>TH7</td> <td rowspan="2">39 to 105 kΩ</td> </tr> <tr> <td>TH8</td> </tr> </tbody> </table>		Normal	Abnormal	TH4	160 to 410 kΩ	Open or short	TH2	4.3 to 9.6 kΩ	TH3	TH6	TH7	39 to 105 kΩ	TH8								
	Normal	Abnormal																				
TH4	160 to 410 kΩ	Open or short																				
TH2	4.3 to 9.6 kΩ																					
TH3																						
TH6																						
TH7	39 to 105 kΩ																					
TH8																						
Fan motor (MF1, MF2) 	Measure the resistance between the connector pins with a multimeter. (At the ambient temperature 68°F [20°C]) <table border="1" style="margin-top: 10px;"> <thead> <tr> <th colspan="4">Normal</th> <th>Abnormal</th> <th>Model name of fan motor *</th> </tr> <tr> <th>1 - 4</th> <th>5 - 4</th> <th>6 - 4</th> <th>7 - 4</th> <td rowspan="3">Open or short (Short, for 7 - 4)</td> <td rowspan="2">SIC-82XX / SIC-88XX</td> </tr> </thead> <tbody> <tr> <td>1.1 ± 0.05 MΩ</td> <td>40 ± 4 kΩ</td> <td>220 ± 22 kΩ</td> <td>Open</td> </tr> <tr> <td>Open</td> <td>150 ± 15kΩ</td> <td>55 ± 11 kΩ</td> <td>Open</td> <td>SIC-71XX / SIC-81XX</td> </tr> </tbody> </table> <p style="font-size: small; margin-top: 5px;">* See the spec name plate indicated in the diagram for the model name of fan motor * Where "X" in model name of fan motor represents numbers and letters</p>	Normal				Abnormal	Model name of fan motor *	1 - 4	5 - 4	6 - 4	7 - 4	Open or short (Short, for 7 - 4)	SIC-82XX / SIC-88XX	1.1 ± 0.05 MΩ	40 ± 4 kΩ	220 ± 22 kΩ	Open	Open	150 ± 15kΩ	55 ± 11 kΩ	Open	SIC-71XX / SIC-81XX
Normal				Abnormal	Model name of fan motor *																	
1 - 4	5 - 4	6 - 4	7 - 4	Open or short (Short, for 7 - 4)	SIC-82XX / SIC-88XX																	
1.1 ± 0.05 MΩ	40 ± 4 kΩ	220 ± 22 kΩ	Open																			
Open	150 ± 15kΩ	55 ± 11 kΩ	Open		SIC-71XX / SIC-81XX																	
Solenoid valve coil <4-way valve> (21S4)	Measure the resistance between the terminals with a multimeter. (At the ambient temperature 68°F [20°C]) <table border="1" style="margin-top: 10px;"> <thead> <tr> <th>Normal</th> <th>Abnormal</th> </tr> </thead> <tbody> <tr> <td>1567.5 ± 156.8Ω</td> <td>Open or short</td> </tr> </tbody> </table>	Normal	Abnormal	1567.5 ± 156.8Ω	Open or short																	
Normal	Abnormal																					
1567.5 ± 156.8Ω	Open or short																					
Motor for compressor (MC) 	Measure the resistance between the terminals with a multimeter. (Winding temperature 68°F [20°C]) <table border="1" style="margin-top: 10px;"> <thead> <tr> <th>Normal</th> <th>Abnormal</th> </tr> </thead> <tbody> <tr> <td>0.305 ± 0.015Ω</td> <td>Open or short</td> </tr> </tbody> </table>	Normal	Abnormal	0.305 ± 0.015Ω	Open or short																	
Normal	Abnormal																					
0.305 ± 0.015Ω	Open or short																					
Solenoid valve coil <Bypass valve> (SV1) <Switching valve> (SV2)*2 *2 Only NAMHZ model.	Measure the resistance between the terminals with a multimeter. (At the ambient temperature 68°F [20°C]) <table border="1" style="margin-top: 10px;"> <thead> <tr> <th>Normal</th> <th>Abnormal</th> </tr> </thead> <tbody> <tr> <td>1197 ± 10Ω</td> <td>Open or short</td> </tr> </tbody> </table>	Normal	Abnormal	1197 ± 10Ω	Open or short																	
Normal	Abnormal																					
1197 ± 10Ω	Open or short																					
Linear expansion Valve (LEV A) 	<table border="1" style="margin-top: 10px;"> <thead> <tr> <th colspan="4">Normal</th> <th>Abnormal</th> </tr> </thead> <tbody> <tr> <td>Gray - Black</td> <td>Gray - Red</td> <td>Gray - Yellow</td> <td>Gray - Orange</td> <td rowspan="2">Open or short</td> </tr> <tr> <td colspan="4" style="text-align: center;">46 ± 3Ω</td> </tr> </tbody> </table>	Normal				Abnormal	Gray - Black	Gray - Red	Gray - Yellow	Gray - Orange	Open or short	46 ± 3Ω										
Normal				Abnormal																		
Gray - Black	Gray - Red	Gray - Yellow	Gray - Orange	Open or short																		
46 ± 3Ω																						
Linear expansion Valve (LEV B) 	<table border="1" style="margin-top: 10px;"> <thead> <tr> <th colspan="4">Normal</th> <th>Abnormal</th> </tr> </thead> <tbody> <tr> <td>Red - White</td> <td>Red - Orange</td> <td>Red - Yellow</td> <td>Red - Blue</td> <td rowspan="2">Open or short</td> </tr> <tr> <td colspan="4" style="text-align: center;">46 ± 4Ω</td> </tr> </tbody> </table>	Normal				Abnormal	Red - White	Red - Orange	Red - Yellow	Red - Blue	Open or short	46 ± 4Ω										
Normal				Abnormal																		
Red - White	Red - Orange	Red - Yellow	Red - Blue	Open or short																		
46 ± 4Ω																						

Check method of DC fan motor (fan motor/outdoor multi controller circuit board)

1. Notes

- High voltage is applied to the connector (CNF1, 2) for the fan motor. Pay attention to the service.
- Do not pull out the connector (CNF1, 2) for the motor with the power supply on.
(It causes trouble of the outdoor multi controller circuit board and fan motor.)

2. Self check

Symptom: The outdoor fan cannot rotate.

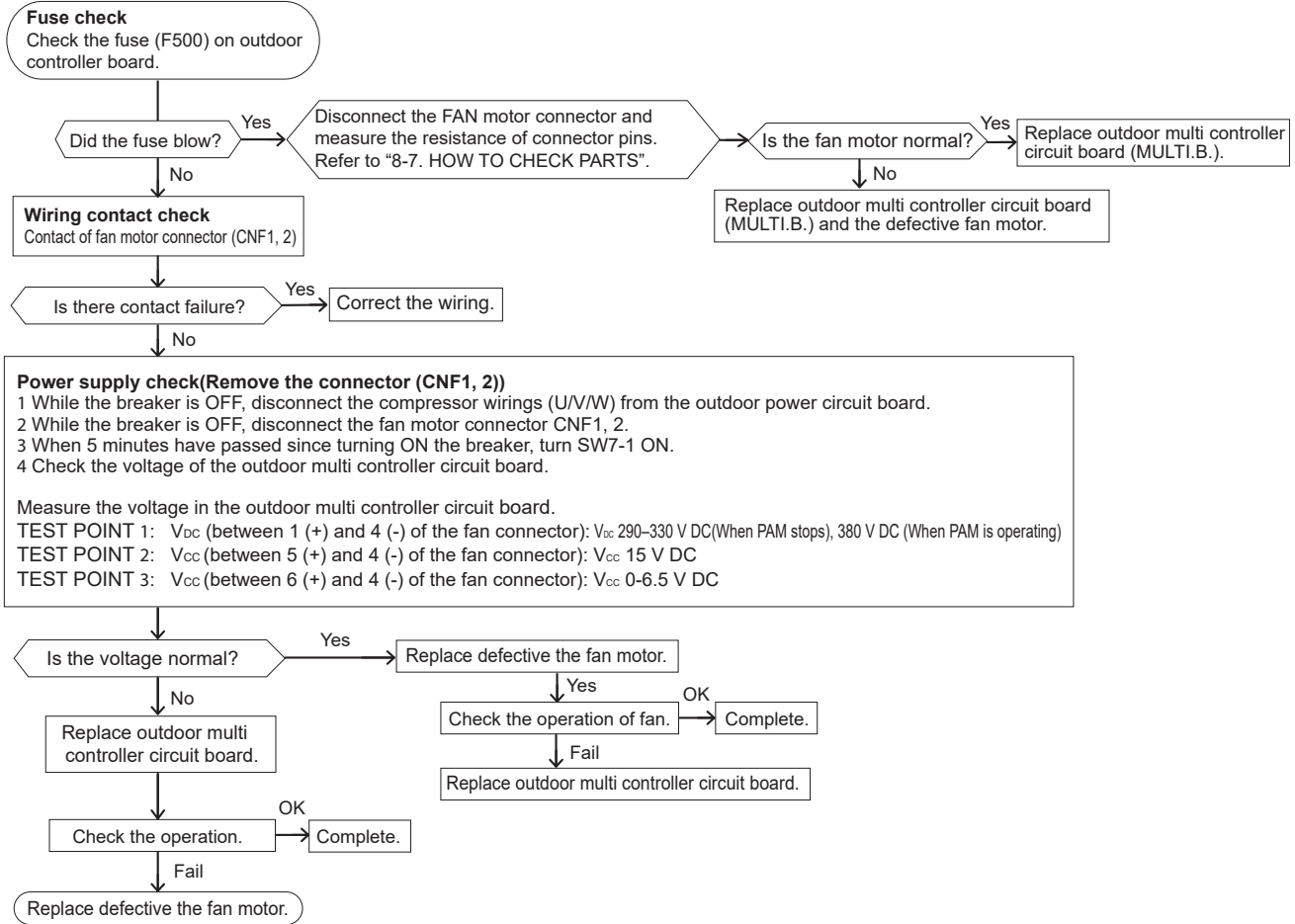

Note: Turn SW7-1 OFF after the troubleshooting completes.

The fan sometimes starts on-off cycle operation during low-load operation or cooling at low ambient temperature. It is not abnormal; the operation ensures reliability of the product.

Check method of multi controller circuit board

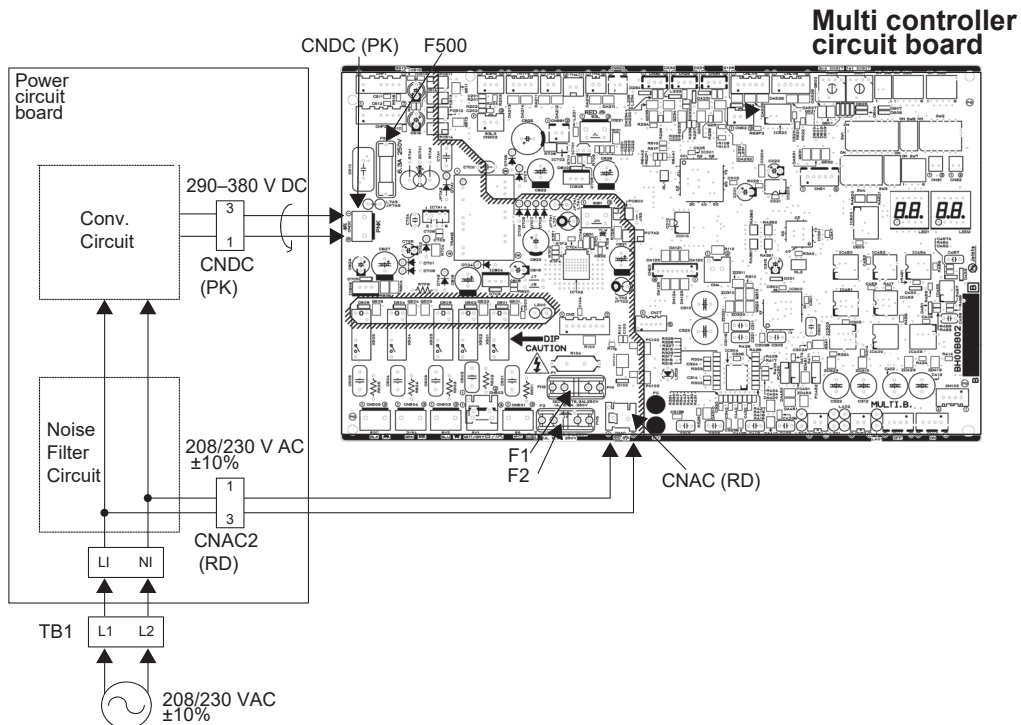
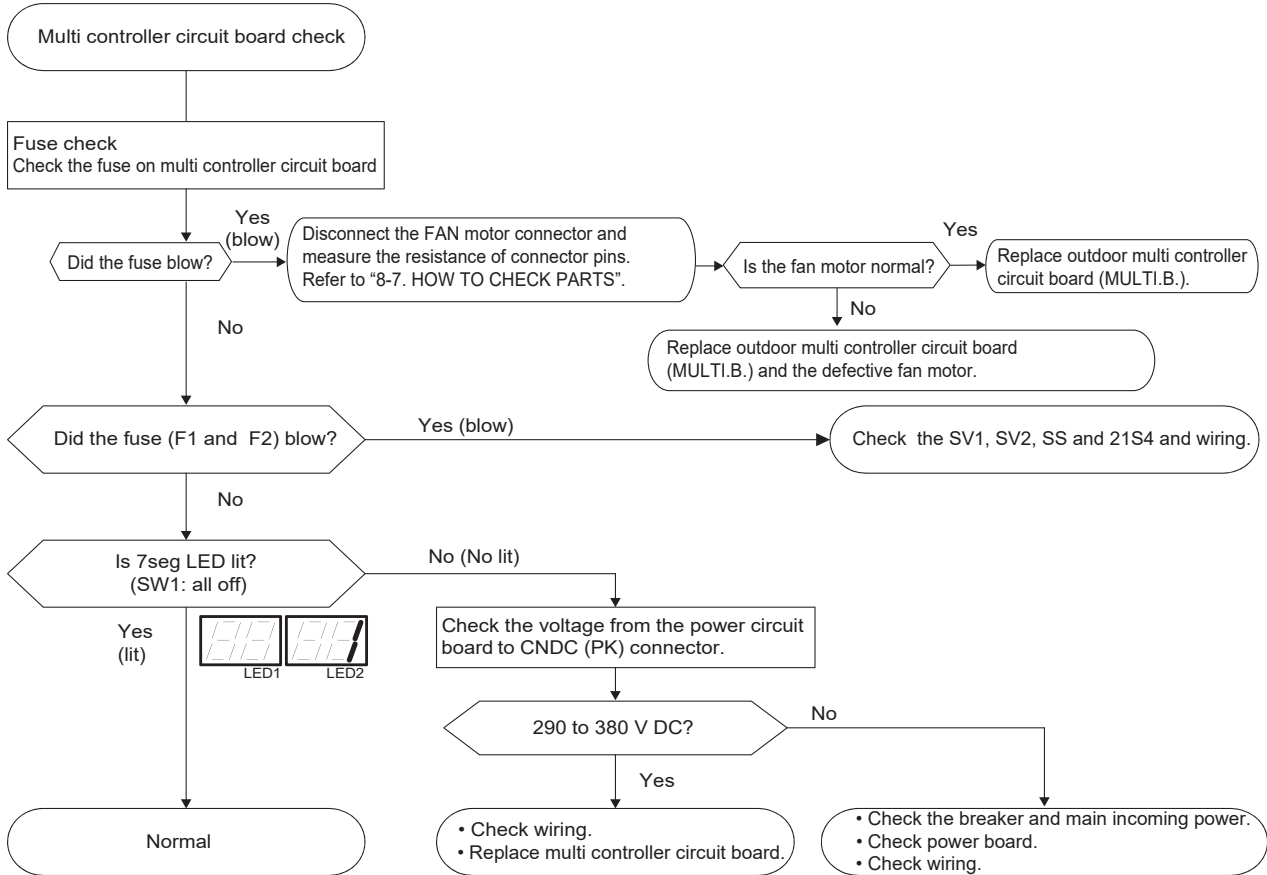

Check method of power circuit board

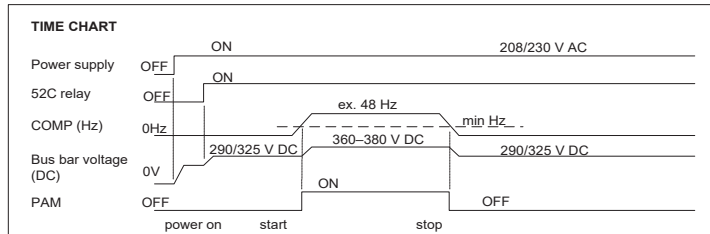
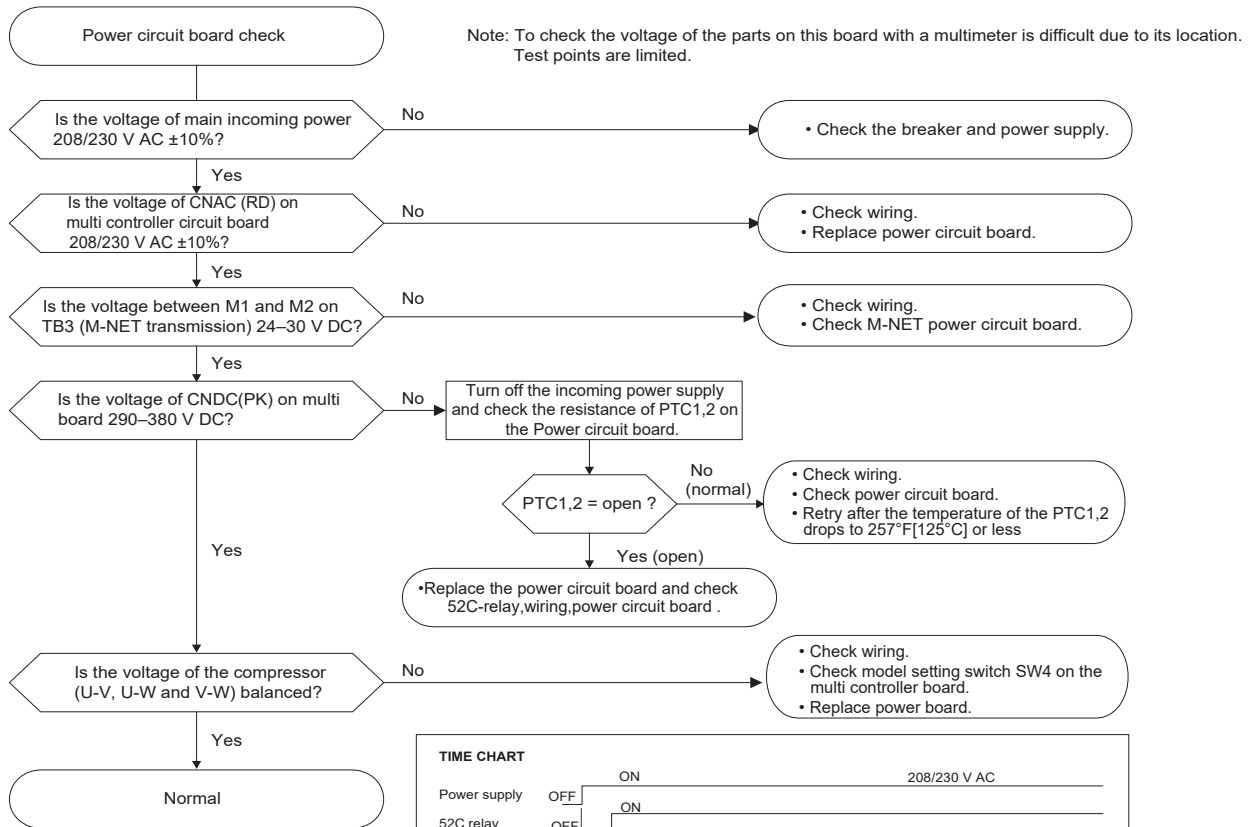

- MXZ-SM60NAM-U1
- MXZ-SM36NAMHZ-U1
- MXZ-SM42NAMHZ-U1
- MXZ-SM48NAMHZ-U1

Power circuit board

Noise filter circuit board

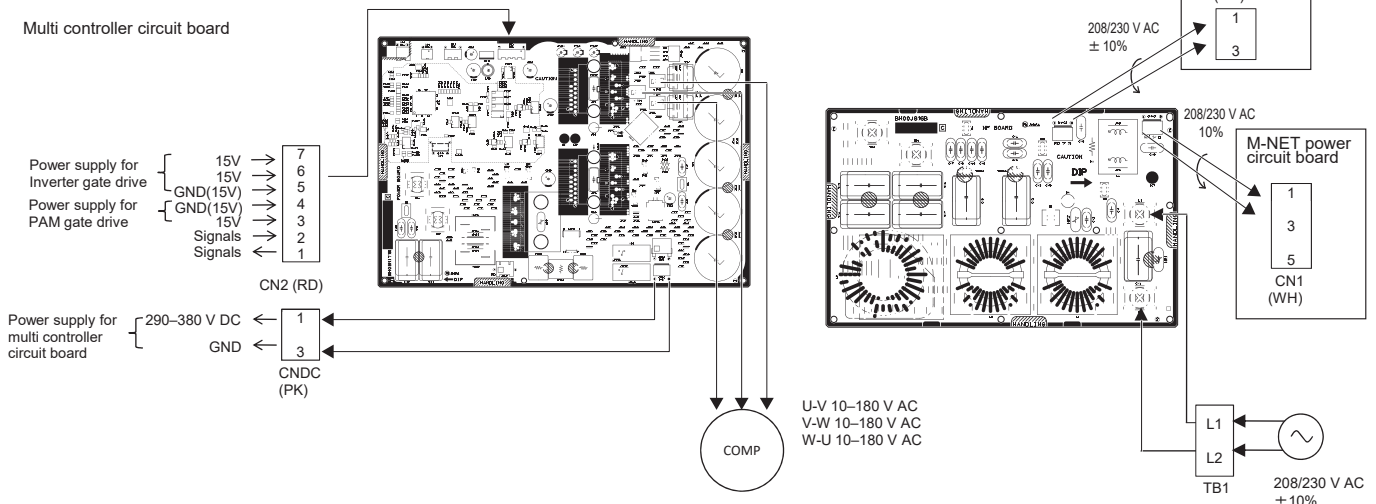

MXZ-SM36NAM-U1
MXZ-SM48NAM-U1

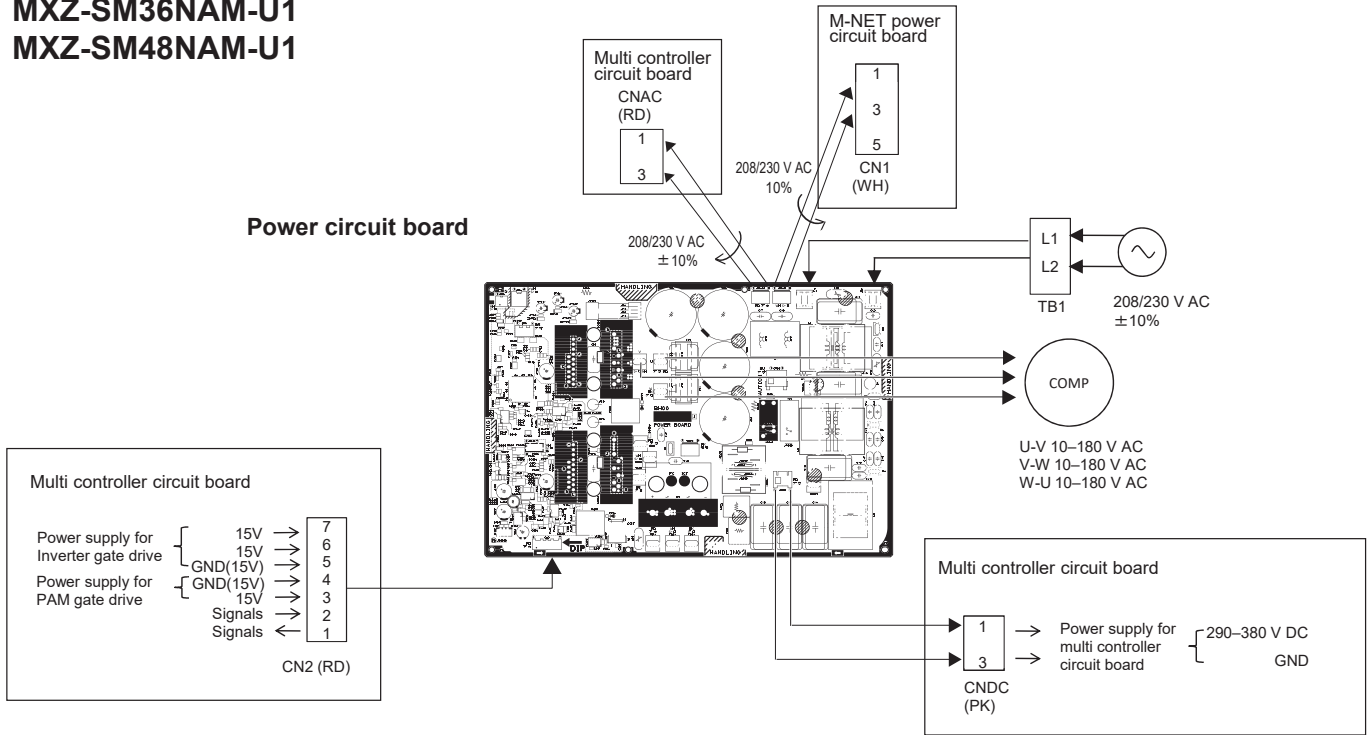

Check method of M-NET power circuit board

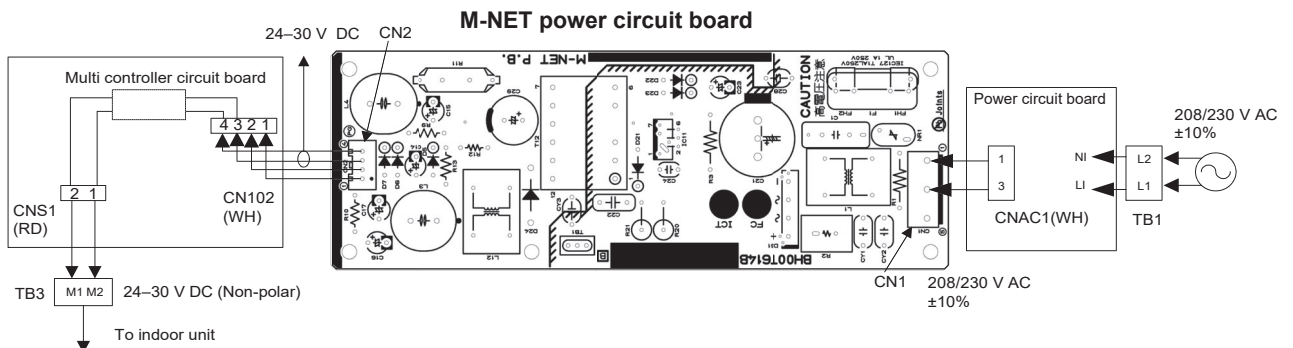
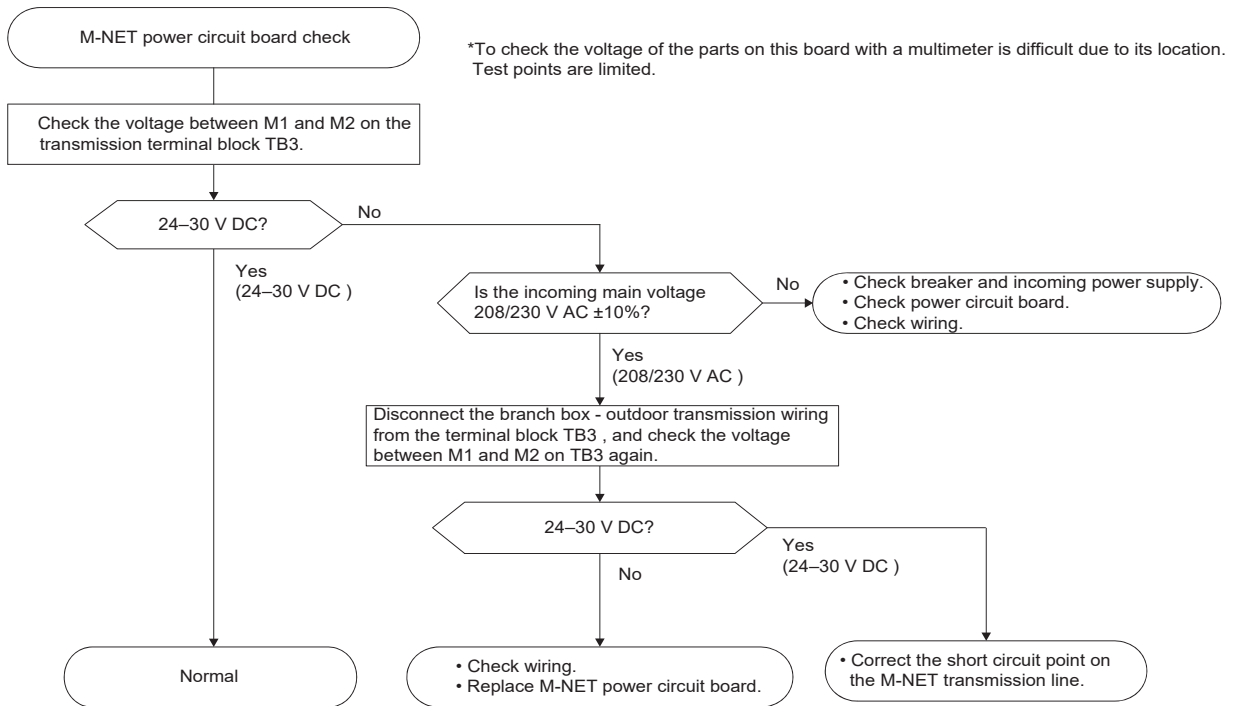

8-8. HOW TO CHECK COMPONENTS

<Thermistor feature chart>

Low temperature thermistors

- Thermistor <Hic pipe> (TH2)
- Thermistor <Outdoor liquid pipe> (TH3)
- Thermistor <Suction pipe> (TH6)
- Thermistor <Ambient> (TH7)

Thermistor R0 = 15 k" ± 3 %
B constant = 3480 ± 1 %

$$R_t = 15 \exp\left\{3480 \left(\frac{1}{273+t} - \frac{1}{273} \right)\right\}$$

32°F [0:]	15 k"	86°F [30:]	4.3 k"
50°F [10:]	9.6 k"	104°F [40:]	3.0 k"
68°F [20:]	6.3 k"		
77°F [25:]	5.2 k"		

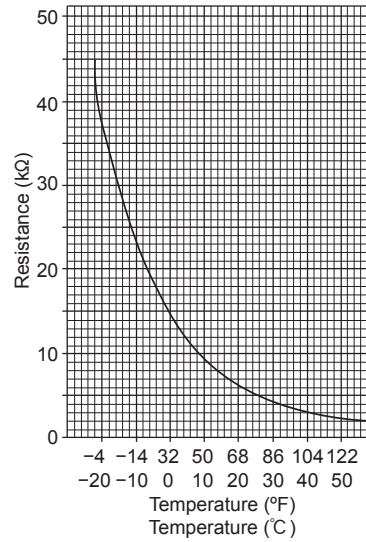

Medium temperature thermistor

- Thermistor <Heat sink> (TH8)

Thermistor R50 = 17 k" ± 2 %
B constant = 4150 ± 3 %

$$R_t = 17 \exp\left\{4150 \left(\frac{1}{273+t} - \frac{1}{323} \right)\right\}$$

0:	180 k"
25:	50 k"
50:	17 k"
70:	8 k"
90:	4 k"

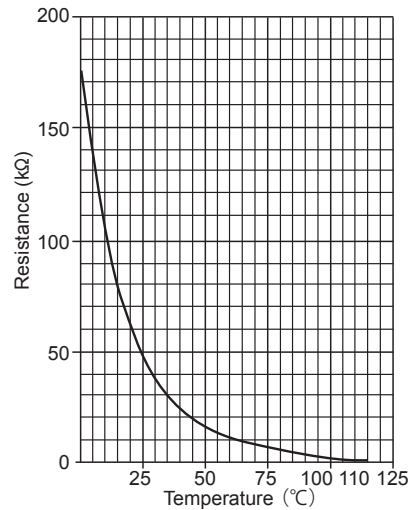

High temperature thermistor

- Thermistor <Compressor> (TH4)

Thermistor R120 = 7.465 k" ± 2 %
B constant = 4057 ± 2 %

$$R_t = 7.465 \exp\left\{4057 \left(\frac{1}{273+t} - \frac{1}{393} \right)\right\}$$

68°F [20:]	250 k"	158°F [70:]	34 k"
86°F [30:]	160 k"	176°F [80:]	24 k"
104°F [40:]	104 k"	194°F [90:]	17.5 k"
122°F [50:]	70 k"	212°F [100:]	13.0 k"
140°F [60:]	48 k"	230°F [110:]	9.8 k"

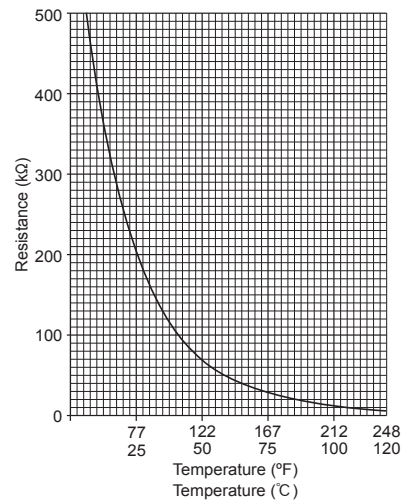

<LOW PRESSURE SENSOR>

• Comparing the Low Pressure Sensor Measurement and Gauge Pressure

By configuring the digital display setting switch (SW1) as shown in the figure below, the pressure as measured by the low pressure sensor appears on the LED1 on the control board.

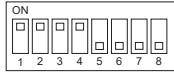
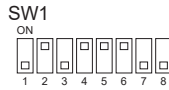

The figure at left shows that the switches 1 through 4 are set to ON and 5 through 8 are set to OFF.

(1) While the outdoor unit is stopped, compare the gauge pressure and the pressure displayed on self-diagnosis LED1, 2.

- 1) When the gauge pressure is between 0 and 14 PSIG [0.098 MPaG], internal pressure is caused due to gas leak.
- 2) When the pressure displayed on self-diagnosis LED1, 2 is between 0 and 14 PSIG [0.098 MPaG], the connector may be defective or be disconnected. Check the connector and go to (4).
- 3) When the outdoor temperature is 86°F [30°C] or less, and the pressure displayed on self-diagnosis LED1, 2 exceeds 247 PSIG [1.7 MPaG], go to (3).
When the outdoor temperature exceeds 86°F [30°C], and the pressure displayed on self-diagnosis LED1, 2 exceeds 247 PSIG [1.7 MPaG], go to (5).
- 4) If other than 1), 2) or 3), compare the pressures while the sensor is running. Go to (2).

(2) Compare the gauge pressure and the pressure displayed on self-diagnosis LED1, 2 after 15 minutes have passed since the start of operation. (Compare them by PSIG [MPaG] unit.)

- 1) When the difference between both pressures is within 29 PSIG [0.2MPaG], both the low pressure sensor and the control board are normal.
- 2) When the difference between both pressures exceeds 29 PSIG [0.2MPaG], the low pressure sensor has a problem. (performance deterioration)
- 3) When the pressure displayed on the self-diagnosis LED1, 2 does not change, the low pressure sensor has a problem.

(3) Remove the low pressure sensor from the control board to check the pressure with the self-diagnosis LED1, 2 display.

- 1) When the pressure displayed on the self-diagnosis LED1,2 is between 0 and 14 PSIG [0.098 MPaG], the low pressure sensor has a problem.
- 2) When the pressure displayed on self-diagnosis LED1, 2 is approximately 247 PSIG [1.7 MPaG], the control board has a problem.

(4) Remove the low pressure sensor from the control board, and short-circuit between the pin 2 and pin 3 connectors (63LS) to check the pressure with the self-diagnosis LED1, 2.

- 1) When the pressure displayed on the self-diagnosis LED1, 2 exceeds 247 PSIG [1.7 MPaG], the low pressure sensor has a problem.
- 2) If other than 1), the control board has a problem.

(5) Remove the high pressure sensor (63HS) from the control board, and insert it into the connector for the low pressure sensor (63LS) to check the pressure with the self-diagnosis LED1, 2.

- 1) When the pressure displayed on the self-diagnosis LED1, 2 exceeds 247 PSIG [1.7 MPaG], the control board has a problem.
- 2) If other than 1), go to (2).

• Low Pressure Sensor Configuration (63LS)

The low pressure sensor consists of the circuit shown in the figure below. If 5 V DC is applied between the red and the black wires, voltage corresponding to the pressure between the white and the black wires will be output, and the value of this voltage will be converted by the microcomputer. The output voltage is 0.173 V per 14 PSIG [0.098 MPaG].

Note:

The pressure sensor on the body side is designed to connect to the connector. The connector pin number on the body side is different from that on the control board side.

	Body side	Control board side
Vcc	Pin 1	Pin 3
Vout	Pin 2	Pin 2
GND	Pin 3	Pin 1

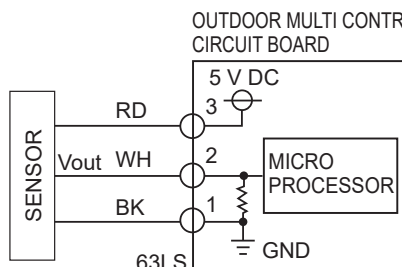

- ③—① : 5 V (DC)
②—① : Output Vout (DC)

Pressure: 0–247 PSIG [1.7 MPaG]
Vout: 0.5–3.5 V
0.173 V/14 PSIG [0.098 MPaG]

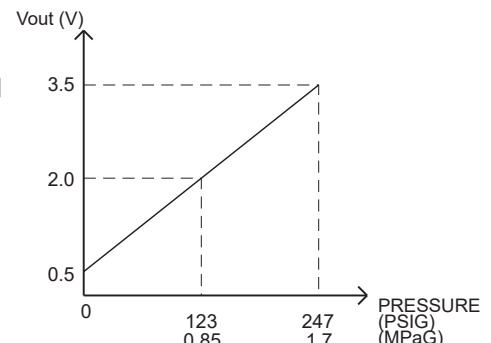

<HIGH PRESSURE SENSOR>

• Comparing the High Pressure Sensor Measurement and Gauge Pressure

By configuring the digital display setting switch (SW1) as shown in the figure below, the pressure as measured by the high pressure sensor appears on the LED1, 2 on the control board.

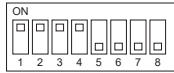

The figure at left shows that the switches 1 through 4 are set to ON and 5 through 8 are set to OFF.

(1) While the outdoor unit is stopped, compare the gauge pressure and the pressure displayed on self-diagnosis LED1, 2.

- 1) When the gauge pressure is between 0 and 14 PSIG [0.098 MPaG], internal pressure is caused due to gas leak.
- 2) When the pressure displayed on self-diagnosis LED1, 2 is between 14 PSIG [0.098 MPaG], the connector may be defective or be disconnected. Check the connector and go to (4).
- 3) When the pressure displayed on self-diagnosis LED1, 2 exceeds 725 PSIG [5.0 MPaG], go to (3).
- 4) If other than 1), 2) or 3), compare the pressures while the sensor is running. Go to (2).

(2) Compare the gauge pressure and the pressure displayed on self-diagnosis LED1,2 after 15 minutes have passed since the start of operation. (Compare them by PSIG [MPaG] unit.)

- 1) When the difference between both pressures is within 36 PSIG [0.25 MPaG], both the high pressure sensor and the control board are normal.
- 2) When the difference between both pressures exceeds 36 PSIG [0.25 MPaG], the high pressure sensor has a problem. (performance deterioration)
- 3) When the pressure displayed on self-diagnosis LED1, 2 does not change, the high pressure sensor has a problem.

(3) Remove the high pressure sensor from the control board to check the pressure on the self-diagnosis LED1, 2.

- 1) When the pressure displayed on self-diagnosis LED1, 2 is between 0 and 14 PSIG [0.098 MPaG], the high pressure sensor has a problem.
- 2) When the pressure displayed on self-diagnosis LED1, 2 is approximately 725 PSIG [5.0 MPaG], the control board has a problem.

(4) Remove the high pressure sensor from the control board, and short-circuit between the pin 2 and pin 3 connectors (63HS) to check the pressure with self-diagnosis LED1, 2.

- 1) When the pressure displayed on the self-diagnosis LED1, 2 exceeds 725 PSIG [5.0 MPaG], the high pressure sensor has a problem.
- 2) If other than 1), the control board has a problem.

• High Pressure Sensor Configuration (63HS)

The high pressure sensor consists of the circuit shown in the figure below. If 5 V DC is applied between the white and the black wires, voltage corresponding to the pressure between the blue and the black wires will be output, and the value of this voltage will be converted by the microcomputer. The output voltage is 0.078 V per 14 PSIG [0.098 MPaG].

Note:

The pressure sensor on the body side is designed to connect to the connector. The connector pin number on the body side is different from that on the control board side.

	Body side	Control board side
Vcc	Pin 1	Pin 3
Vout	Pin 2	Pin 2
GND	Pin 3	Pin 1

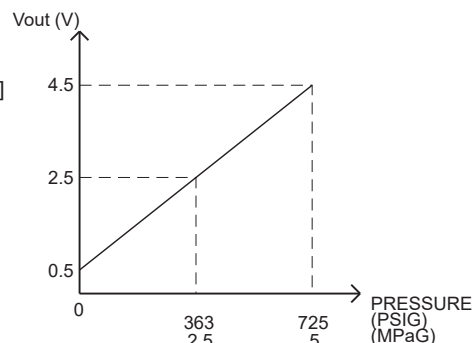
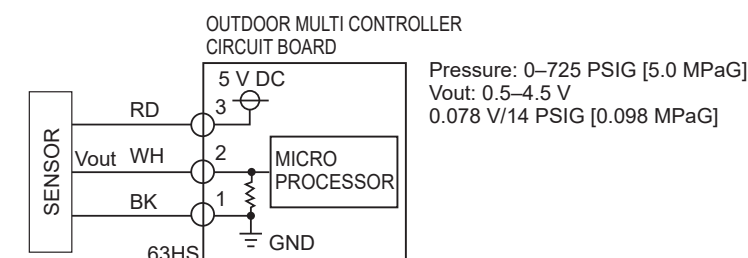

- ③-① : 5 V (DC)
②-① : Output Vout (DC)

8-9. TEST POINT DIAGRAM

Outdoor multi controller circuit board

<CAUTION> TEST POINT 1 is high voltage.

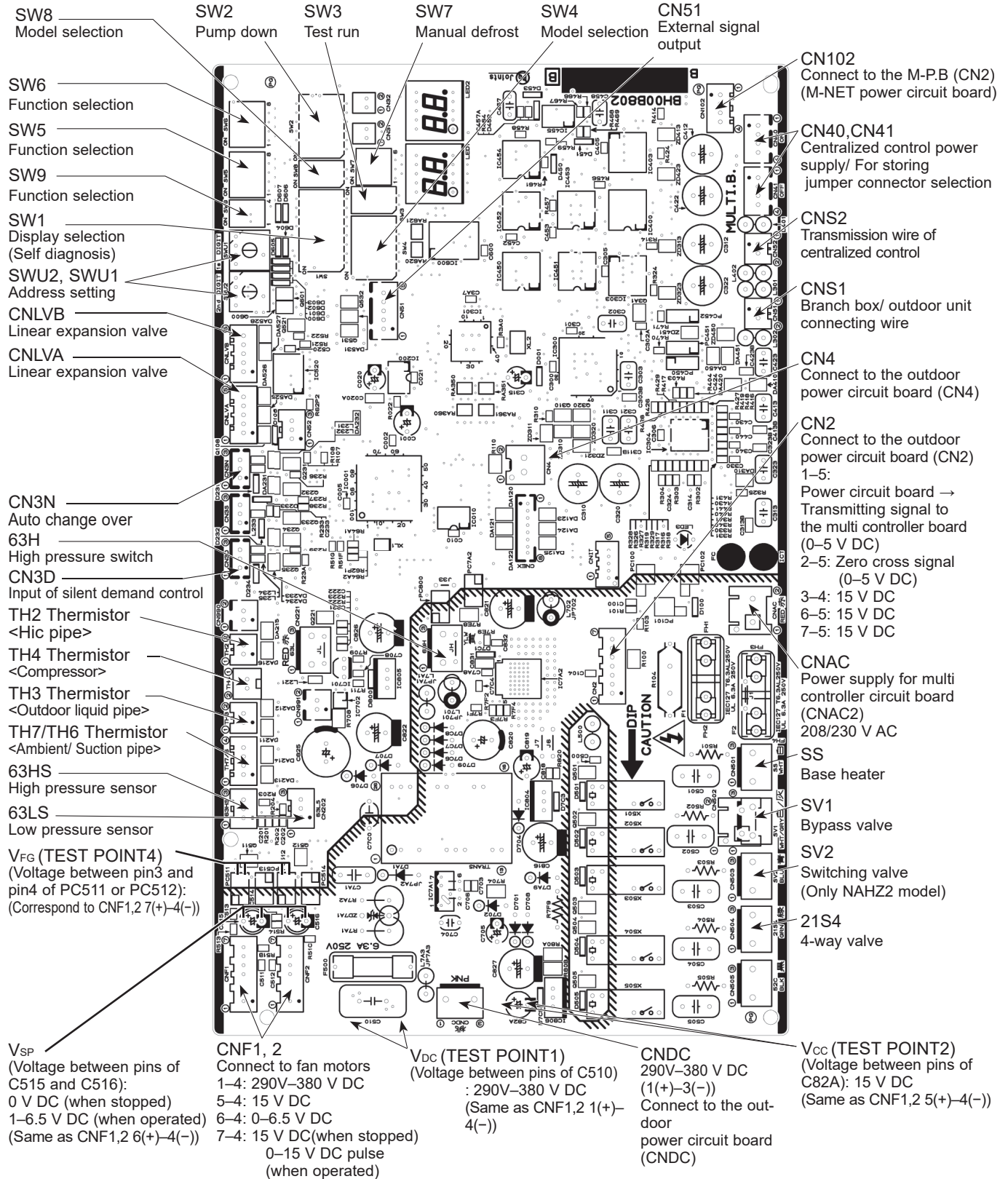

Outdoor power circuit board

MXZ-SM60NAM-U1
 MXZ-SM36NAMHZ-U1
 MXZ-SM42NAMHZ-U1
 MXZ-SM48NAMHZ-U1

Brief Check of POWER MODULE

If they are short-circuited, it means that they are broken.
 Measure the resistance in the following points (connectors, etc.).

1. Check of POWER MODULE

1 Check of DIODE circuit

R - L1, S - L1, R - N1, S - N1

2 Check of IGBT circuit

L2 - N1

3 Check of INVERTER circuit

P - U, P - V, P - W, N1 - U, N1 - V, N1 - W

Note: The marks R, S, L1, L2, P, N1, U, V and W shown in the diagram are not actually printed on the board.

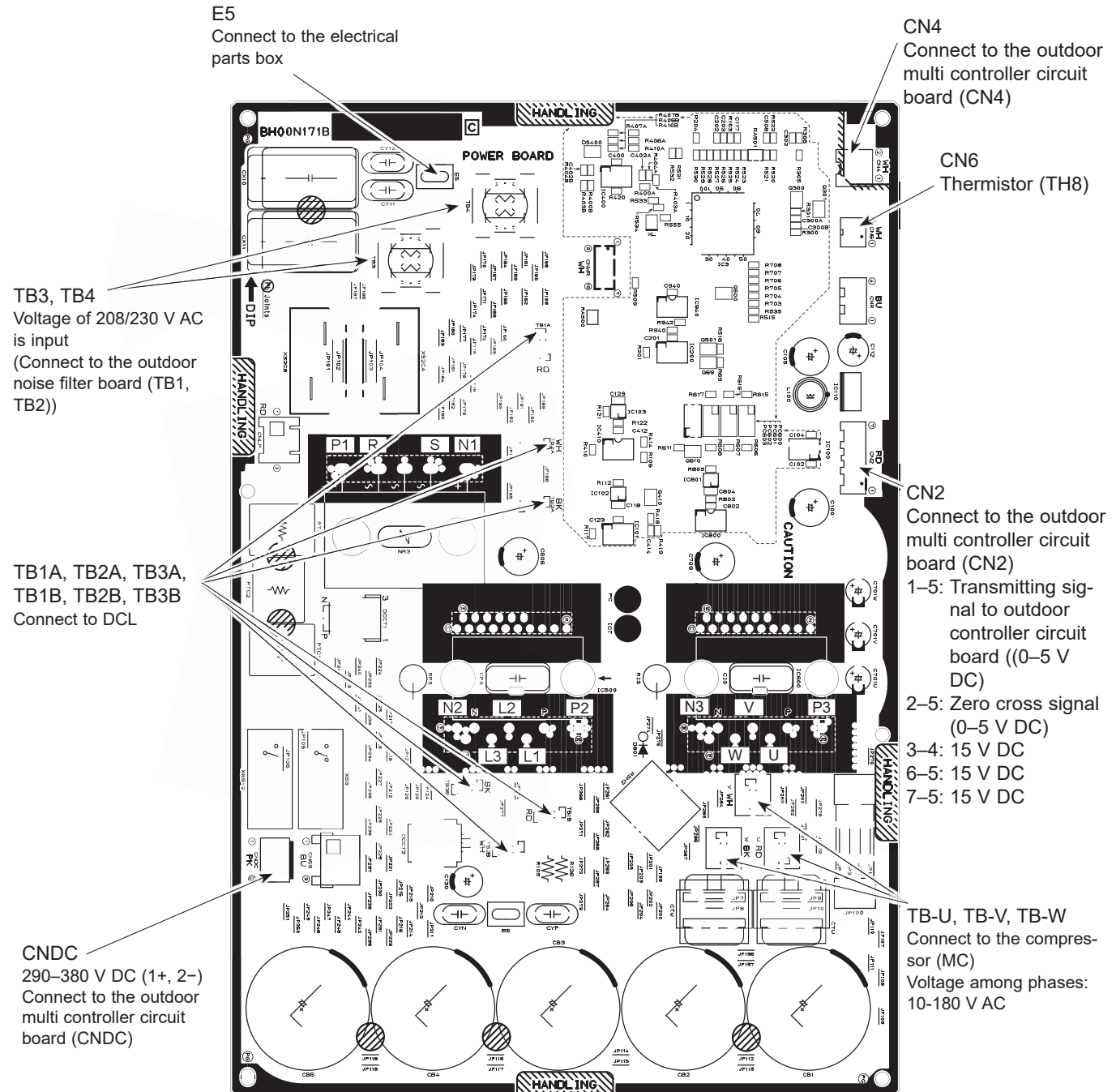

Outdoor power circuit board

MXZ-SM36NAM-U1
MXZ-SM48NAM-U1

CN2

Connect to the outdoor multi controller circuit board (CN2)

- 1-5: Transmitting signal to outdoor controller circuit board ((0-5 V DC)
- 2-5: Zero cross signal (0-5 V DC)
- 3-4: 15 V DC
- 6-5: 15 V DC
- 7-5: 15 V DC

TB1B, TB2B, TB3B, TB1A, TB2A, TB3A
Connect to DCL

CNDC
290-380 V DC (1+, 3-)
Connect to the outdoor controller circuit board (CNDC)

Brief Check of POWER MODULE

If they are short-circuited, it means that they are broken.
Measure the resistance in the following points (connectors, etc.).

1. Check of POWER MODULE

1 Check of DIODE circuit

R - P1 S - P1 R - N1 S - N1

2 Check of IGBT circuit

P2 - L1 P2 - L2 N2 - L1 N2 - L2

3 Check of INVERTER circuit

P3 - U , P3 - V , P3 - W , N3 - U , N3 - V , N3 - W

Note: The marks R , S , L1 , L2 , P1 , N1 , U , V and W shown in the diagram are not actually printed on the board.

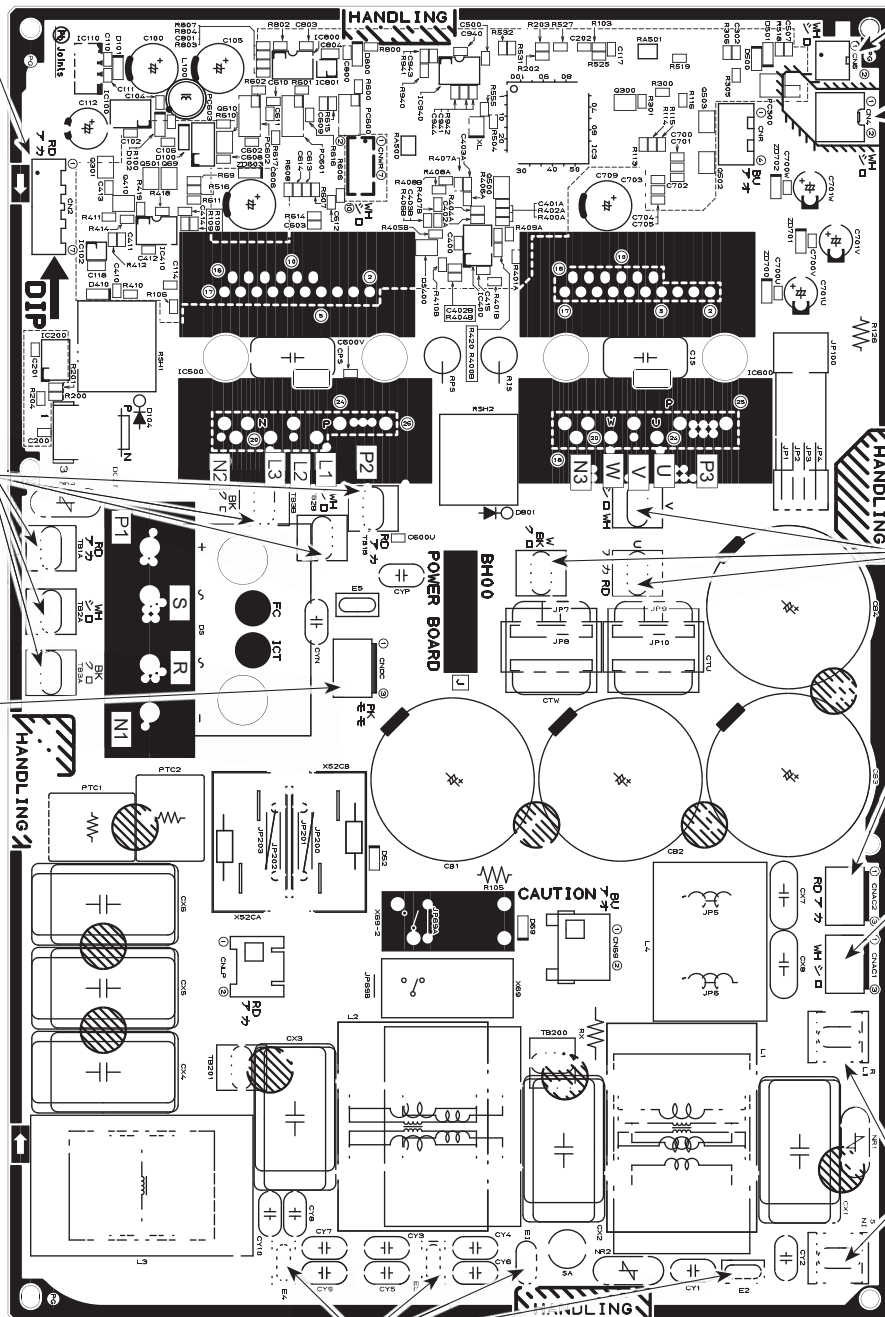

CN6
Thermistor (TH8)

CN4
Connect to the outdoor multi controller circuit board (CN4)

U/V/W
Connect to the compressor (MC) Voltage among phases: 10-180 V AC

CNAC2
208/230 V AC
Connect to the outdoor multi controller circuit board (CNAC)

CNAC1
208/230 V AC
Connect to the M-NET power circuit board (CN1)

R/LI, S/NI
Voltage of 208/230 V AC is input (Connect to the terminal block (TB1))

E1, E2, E3, E4
Connect to the electrical parts box

Outdoor noise filter circuit board

- MXZ-SM60NAM-U1
- MXZ-SM36NAMHZ-U1
- MXZ-SM42NAMHZ-U1
- MXZ-SM48NAMHZ-U1

LI, NI
POWER SUPPLY
Voltage of 208/230 V AC is input
(Connect to the terminal block (TB1))

CNAC1
208/230 V AC
Connect to the M-NET
power circuit board (CN1)

CNAC2
208/230 V AC
Connect to the outdoor
multi controller circuit
board (CNAC)

E1, E2, E3, E4
Connect to the electrical
parts box

TB1, TB2
POWER SUPPLY
Voltage of 208/230 V AC
(Connect to the outdoor
power circuit board (TB3,
TB4))

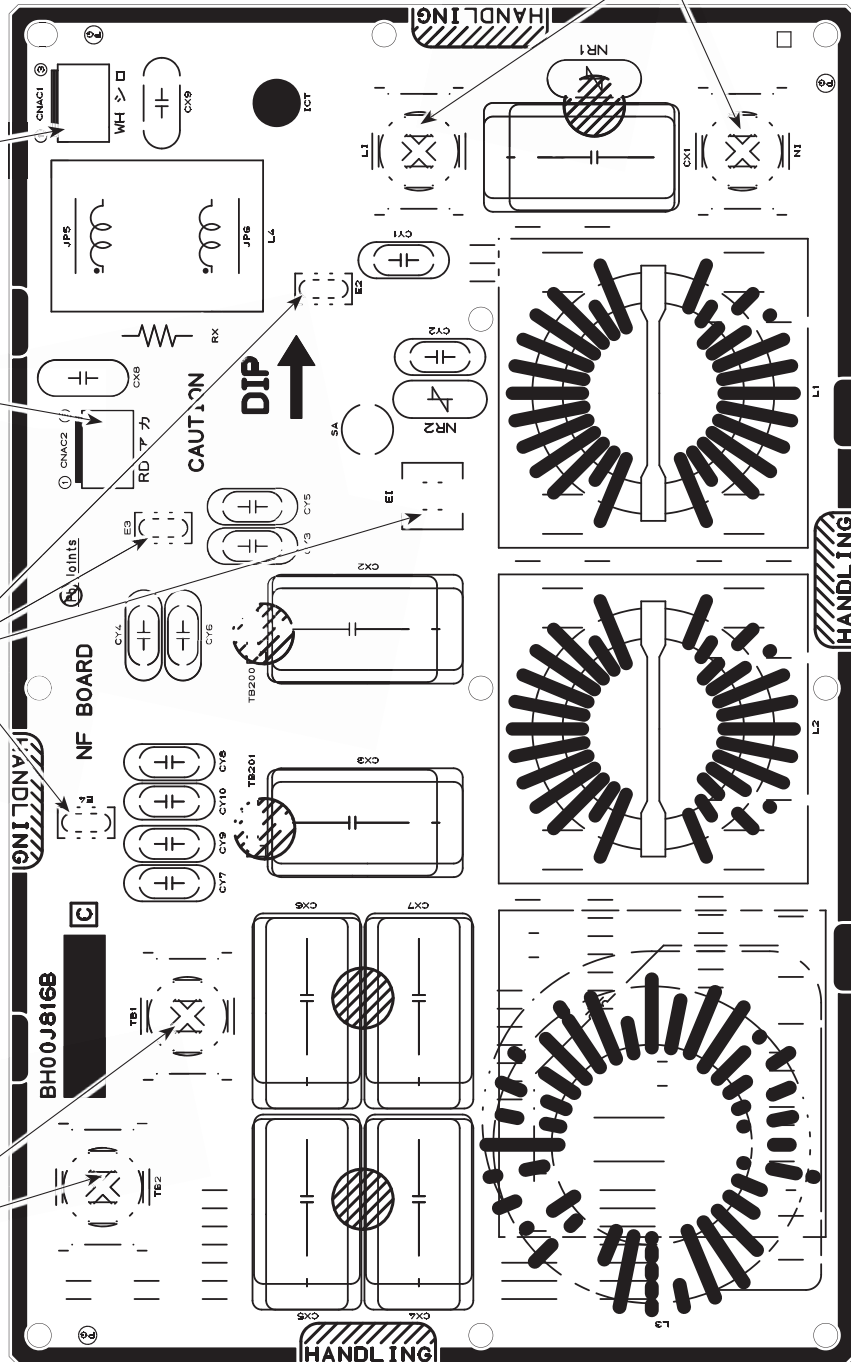

M-NET power circuit board

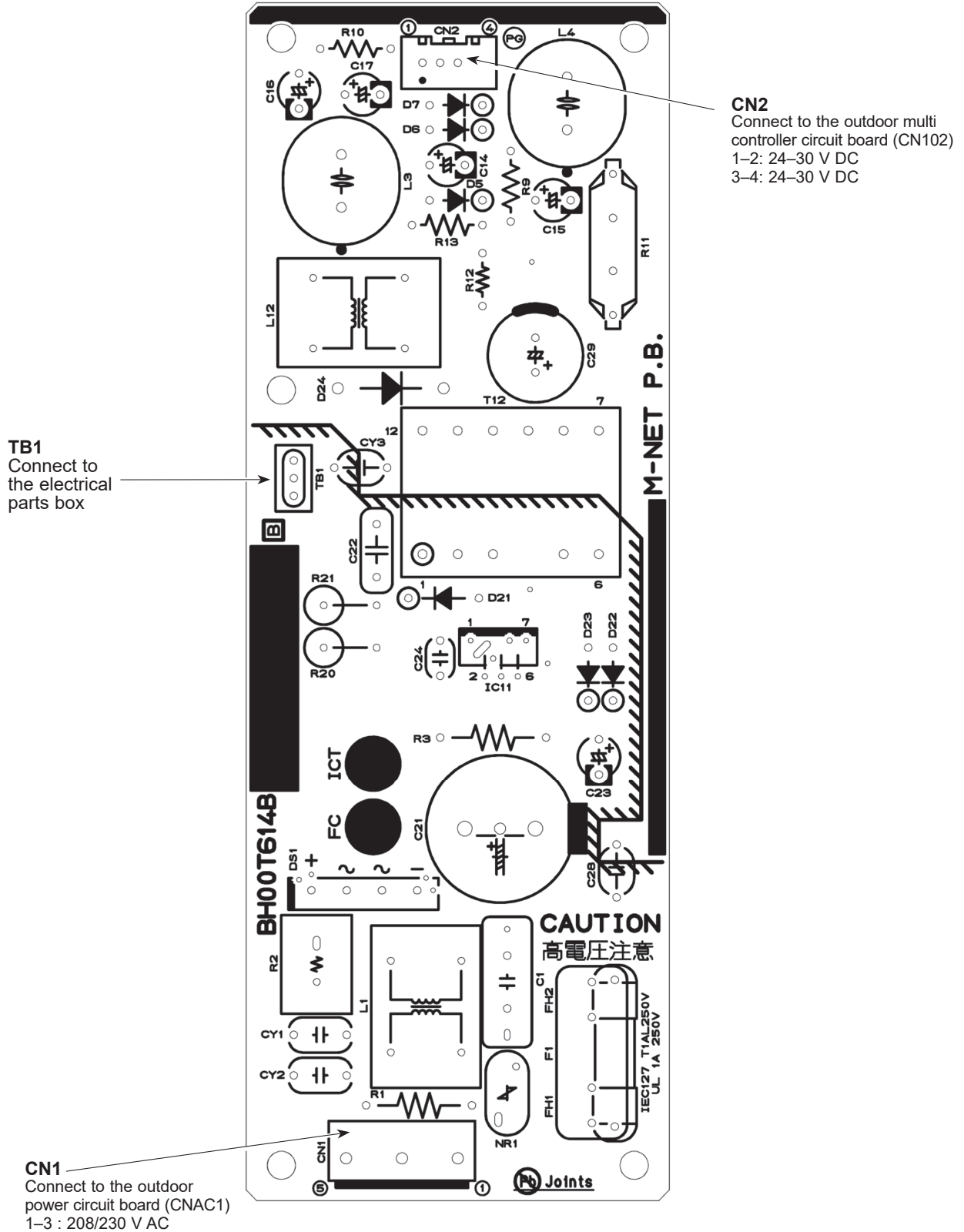

8-10. OUTDOOR UNIT FUNCTIONS

SW: setting
0...OFF
1...ON

No.	SW1 setting	Display mode	Display on the LED1, 2 (display data)								Notes		
			1	2	3	4	5	6	7	8			
0	00000000	Relay output display	Compressor operation	52C	21S4	SV1	(SV2)				Always lighting	ON: light on OFF: light off	
1	10000000	Check display	0000-9999 (Alternating display of addresses and check code)									•When abnormality occurs, check display. Light on at time of abnormality	
2	01000000	Indoor unit check status	No.1 unit check	No.2 unit check	No.3 unit check	No.4 unit check	No.5 unit check	No.6 unit check	No.7 unit check	No.8 unit check			
3	11000000	Protection input	High pressure abnormality	Superheat due to low discharge temperature	Compressor shell temperature abnormality	TH4 abnormality	TH3 abnormality	Outdoor fan rotation frequency abnormality	TH7 abnormality	TH8 abnormality			
4	00100000	Protection input	Heat sink overheating	Compressor over current interception	Voltage abnormality	Insufficient refrigerant amount abnormality	Indoor unit capacity error	63LS abnormality	63HS abnormality	start over current interception abnormality delay		Display detected microprocessor protection or abnormality	
5	10100000	Protection input	Abnormality in the number of indoor units	Address double setting abnormality	Indoor unit capacity error	Over capacity		Outdoor unit address error	Current sensor open/short	serial communication abnormality (outdoor unit)			
6	01100000	Abnormality delay display 1	High pressure abnormality delay	Superheat due to low discharge temperature delay	Compressor shell temperature abnormality delay	TH4 abnormality delay	TH3 abnormality delay	TH4 abnormality frequency abnormality delay	TH7 abnormality delay	TH8 abnormality delay		Display all abnormalities remaining in abnormality delay	
7	11100000	Abnormality delay display 2	Heat sink overheating delay	Compressor over current interception delay	Voltage abnormality delay	Insufficient refrigerant amount abnormality delay	Current sensor/primary current abnormality delay	63LS abnormality delay	63HS abnormality delay	start over current interception abnormality delay			
8	00010000	Abnormality delay display 3	63LS abnormality delay	TH2 abnormality delay	4-way valve abnormality delay	Delay caused by blocked valve in cooling mode	Power module abnormality delay	TH6 abnormality delay	Current sensor open/short delay				
9	10010000	Abnormality delay history 1	High pressure abnormality delay	Superheat due to low discharge temperature delay	Compressor shell temperature abnormality delay	TH4 abnormality delay	TH3 abnormality delay	Outdoor fan rotation frequency abnormality delay	TH7 abnormality delay	TH8 abnormality delay		Display all abnormalities remaining in abnormality delay	
10	01010000	Abnormality delay history 2	Heat sink overheating delay	Compressor over current interception delay	Voltage abnormality delay	Insufficient refrigerant amount abnormality delay	Current sensor/primary current abnormality delay	63LS abnormality delay	63HS abnormality delay	start over current interception abnormality delay			
11	11010000	Abnormality delay history 3	63LS abnormality delay	TH2 abnormality delay	4-way valve abnormality delay	Delay caused by blocked valve in cooling mode	Power module abnormality delay	TH6 abnormality delay	Current sensor open/short delay				
12	00110000	Abnormality code history 1 (the latest)	Abnormality code history 1	Abnormality code history 2	Abnormality code history 3	Abnormality code history 4	Abnormality code history 5	Abnormality code history 6	Abnormality code history 7	Abnormality code history 8	Abnormality code history 9	Abnormality code history 10 (the oldest)	Display of cumulative compressor operating time
13	10110000	Abnormality code history 2	Abnormality code history 2	Abnormality code history 3	Abnormality code history 4	Abnormality code history 5	Abnormality code history 6	Abnormality code history 7	Abnormality code history 8	Abnormality code history 9	Abnormality code history 10 (the oldest)		Display of cumulative compressor operating time
14	01110000	Abnormality code history 3	Abnormality code history 3	Abnormality code history 4	Abnormality code history 5	Abnormality code history 6	Abnormality code history 7	Abnormality code history 8	Abnormality code history 9	Abnormality code history 10 (the oldest)			Light ON/Light OFF
15	11110000	Abnormality code history 4	Abnormality code history 4	Abnormality code history 5	Abnormality code history 6	Abnormality code history 7	Abnormality code history 8	Abnormality code history 9	Abnormality code history 10 (the oldest)				Cooling : light on, Heating: light blinking Stop fan: light off
16	00001000	Abnormality code history 5	Abnormality code history 5	Abnormality code history 6	Abnormality code history 7	Abnormality code history 8	Abnormality code history 9	Abnormality code history 10 (the oldest)					Thermo ON: light on Thermo OFF: light off
17	10001000	Abnormality code history 6	Abnormality code history 6	Abnormality code history 7	Abnormality code history 8	Abnormality code history 9	Abnormality code history 10 (the oldest)						
18	01001000	Abnormality code history 7	Abnormality code history 7	Abnormality code history 8	Abnormality code history 9	Abnormality code history 10 (the oldest)							
19	11001000	Abnormality code history 8	Abnormality code history 8	Abnormality code history 9	Abnormality code history 10 (the oldest)								
20	00101000	Abnormality code history 9	Abnormality code history 9	Abnormality code history 10 (the oldest)									
21	10101000	Abnormality code history 10 (the oldest)	Abnormality code history 10 (the oldest)										
22	01101000	Cumulative time	0-9999 (unit: 1 hour)										
23	11101000	Cumulative time	0-9999 (unit: 10 hour)										
24	00011000	Outdoor unit operation display	Compressor energizing	Compressor operating prohibition	Compressor in operation	Abnormality detection							
25	10011000	Indoor unit operation mode	No.1 unit mode	No.2 unit mode	No.3 unit mode	No.4 unit mode	No.5 unit mode	No.6 unit mode	No.7 unit mode	No.8 unit mode			
26	10011000	Indoor unit operation display	No.1 unit operation	No.2 unit operation	No.3 unit operation	No.4 unit operation	No.5 unit operation	No.6 unit operation	No.7 unit operation	No.8 unit operation			

No.	SW1 setting	Display mode	Display on the LED 1, 2 (display data)								Notes	
			1	2	3	4	5	6	7	8		
86	01101010	IC1 TH22 (Liquid)	-99.9~999.9 (°F) (When the indoor unit is not connected, it is displayed as 0.)								Display detected data of indoor unit thermistors	
87	11101010	IC2 TH22 (Liquid)										
88	00011010	IC3 TH22 (Liquid)										
89	10011010	IC4 TH22 (Liquid)										
90	01011010	IC5 TH22 (Liquid)										
91	11011010	IC1 TH21 (Intake)										
92	00111010	IC2 TH21 (Intake)										
93	10111010	IC3 TH21 (Intake)										
94	01111010	IC4 TH21 (Intake)										
95	11111010	IC5 TH21 (Intake)										
96	00000110	Outdoor SC (cooling)	-99.9~999.9 (°C)								Display of outdoor subcool (SC) data	
97	10000110	Target subcool step	-2~4								Display of target subcool step data	
98	01000110	IC1 SC/SH									Display of indoor SC/SH data	
99	11000110	IC2 SC/SH										
100	00100110	IC3 SC/SH										
101	10100110	IC4 SC/SH										
102	01100110	IC5 SC/SH										
103	11100110	Discharge superheat (SHd)	-99.9~999.9 (°C)									Display of outdoor discharge superheat (SHd) data
105	10010110	Target Pd display (heating) (kgf)	PdM (0.0~30.0) (kgf/cm ²)									Display of all control target data
106	01010110	Target ET display (cooling)	ETm (-2.0~23.0) (°C)									
107	11010110	Target outdoor SC (cooling)	SCm (0.0~20.0) (°C)									
108	00110110	Target indoor SC/SH (IC1)										
109	10110110	Target indoor SC/SH (IC2)										
110	01110110	Target indoor SC/SH (IC3)										
111	11110110	Target indoor SC/SH (IC4)										
112	00001110	Target indoor SC/SH (IC5)										
113	10001110	Indoor unit check status (IC9-12)	No.9 unit check	No.10 unit check	No.11 unit check	No.12 unit check						
114	01001110	Indoor unit operation mode (IC9-12)	No.9 unit mode	No.10 unit mode	No.11 unit mode	No.12 unit mode						
115	11001110	Indoor unit operation display (IC9-12)	No.9 unit operation	No.10 unit operation	No.11 unit operation	No.12 unit operation						
116	00101110	IC9 operation mode	STOP		Heating thermo-ON		Heating thermo-OFF					
117	10101110	IC10 operation mode	Fan		Cooling Thermo-ON		Cooling thermo-OFF					
118	01101110	IC11 operation mode			Cooling Thermo-ON		Cooling thermo-OFF					
119	11101110	IC12 operation mode			Cooling Thermo-ON		Cooling thermo-OFF					
120	00011110	Target indoor SC/SH (IC9)	SCm/SHm (0.0~20.0) (°C)								Display of all control target data	
121	10011110	Target indoor SC/SH (IC10)										
122	01011110	Target indoor SC/SH (IC11)										
123	11011110	Target indoor SC/SH (IC12)										
124	00111110	IC9 LEV opening pulse abnormality delay	0~2000 (pulse)									Display of opening pulse of indoor LEV at time of abnormality delay
125	10111110	IC10 LEV opening pulse abnormality delay										
126	01111110	IC11 LEV opening pulse abnormality delay										
127	11111110	IC12 LEV opening pulse abnormality delay										

No.	SW1 setting	Display mode	Display on the LED1, 2 (display data)								Notes
			1	2	3	4	5	6	7	8	
128	00000001	Actual frequency of abnormality delay	0-255 (Hz)								Display of actual frequency at time of abnormality delay
129	10110001	Fan step number at time of abnormality delay	0-15								Display of fan step number at time of abnormality delay
131	11000001	IC1 LEV opening pulse abnormality delay	0-2000 (pulse)								Delay of opening pulse of indoor LEV at time of abnormality delay
132	00100001	IC2 LEV opening pulse abnormality delay									
133	10100001	IC3 LEV opening pulse abnormality delay									
134	01100001	IC4 LEV opening pulse abnormality delay									
135	11100001	IC5 LEV opening pulse abnormality delay									
136	00010001	High pressure sensor data at time of abnormality delay kgf/cm2	-99.9-999.9 (PSIG)								
137	10010001	TH4 (Compressor) sensor data at time of abnormality delay °C	-99.9-999.9 (°F)								
138	01010001	TH6 (Suction pipe) sensor data at time of abnormality delay °C									
139	11010001	TH3 (Outdoor liquid pipe) sensor data at time of abnormality delay °C									
140	00110001	TH8 (Heat sink) sensor data at time of abnormality delay °C	-99.9-999.9(°) During heating: subcool (SC) During cooling: superheat (SH) (Fixed to "0" during cooling operation)								Display of data from High pressure sensor, all thermistors, and SC/SH at time of abnormality delay
141	10110001	OC SC (cooling) at time of abnormality delay °C									
142	01110001	IC1 SC/SH at time of abnormality delay °C									
143	11110001	IC2 SC/SH at time of abnormality delay °C									
144	00001001	IC3 SC/SH at time of abnormality delay °C									
145	10001001	IC4 SC/SH at time of abnormality delay °C									
146	01001001	IC5 SC/SH at time of abnormality delay °C									
147	11001001	IC9 SC/SH at time of abnormality delay °C									
148	00100001	IC10 SC/SH at time of abnormality delay °C									
149	10101001	IC11 SC/SH at time of abnormality delay °C									
150	01101001	IC12 SC/SH at time of abnormality delay °C									

No.	SW1 setting	Display mode	Display on the LED1, 2 (display data)								Notes
			1	2	3	4	5	6	7	8	
151	11101001	IC9 LEV opening pulse at time of abnormality	0-2000 (pulse)								Display of opening pulse of indoor LEV at time of abnormality
152	00011001	IC10 LEV opening pulse at time of abnormality									
153	10011001	IC11 LEV opening pulse at time of abnormality									
154	01011001	IC12 LEV opening pulse at time of abnormality									
155	11011001	IC9 SC/SH at time of abnormality									
156	00111001	IC10 SC/SH at time of abnormality									
157	10111001	IC11 SC/SH at time of abnormality	-99.9-999.9(:) During heating: subcool (SC) During cooling: superheat (SH) (Fixed to "0" during cooling operation)								Display of indoor SC/SH data at time of abnormality
158	01111001	IC12 SC/SH at time of abnormality									
159	11111001	IC9 Capacity code									Display of indoor unit capacity code
160	0000101	IC10 Capacity code									The No.1 unit will start from the M-NET address with the lowest number
161	10000101	IC11 Capacity code									
162	01000101	IC12 Capacity code									
163	11000101	IC9 SC/SH									
164	00100101	IC10 SC/SH									
165	10100101	IC11 SC/SH	-99.9-999.9(:) During heating: subcool (SC) During cooling: superheat (SH) (Fixed to "0" during cooling operation)								Display of indoor SC/SH data
166	01100101	IC12 SC/SH									
170	01010101	ROM version monitor	0.00-99.99 (ver)								Display of version data of ROM
171	11010101	ROM type									Display of ROM type
172	00110101	Check sum mode	0000-FFFF								Display of check sum code of ROM
173	10110101	IC9 TH23 (Gas)									
174	01110101	IC10 TH23 (Gas)									
175	11110101	IC11 TH23 (Gas)									
176	00001101	IC12 TH23 (Gas)									
177	10001101	IC9 TH22 (Liquid)									
178	01001101	IC10 TH22 (Liquid)									
179	11001101	IC11 TH22 (Liquid)									
180	00101101	IC12 TH22 (Liquid)									
181	10101101	Backup heating determination value "a"	-99.9-999.9 (°F)								Display detected data of indoor unit thermistors
182	01101101	Backup heating determination value "b"									
183	11101101	Backup heating determination value "c"									
184	00011101	Backup heating determination value "d"									
185	10011101	IC9 TH21 (Intake)									
186	01011101	IC10 TH21 (Intake)									
187	11011101	IC11 TH21 (Intake)									
188	00111101	IC12 TH21 (Intake)									

No.	SW1 setting	Display mode	Display on the LED1, 2 (display data)								Notes	
			1	2	3	4	5	6	7	8		
189	10111101	History of voltage error (U9/4.220)	-	-	PAM error	Converter Fault	Power synchronization signal error	L1 open phase error	Under voltage error	Over voltage error		
190	01111101	External connection status at time of abnormality delay	CN3N 1-3 input	CN3N 1-2 input	CN3S 1-2 input	CN3D 1-3 input	CN3D 1-2 input					
191	11111101	External connection status at time of abnormality	CN3N 1-3 input	CN3N 1-2 input	CN3S 1-2 input	CN3D 1-3 input	CN3D 1-2 input					
192	00000011	Actual frequency of abnormality	0-255 (Hz)									Display of actual frequency at time of abnormality
193	10000011	Fan step number at time of abnormality	0-15									Display of fan step number at time of abnormality
195	11000011	IC1 LEV opening pulse at time of abnormality	0-2000 (pulse)									Display of opening pulse of indoor LEV at time of abnormality
196	00100011	IC2 LEV opening pulse at time of abnormality										
197	10100011	IC3 LEV opening pulse at time of abnormality										
198	01100011	IC4 LEV opening pulse at time of abnormality										
199	11100011	IC5 LEV opening pulse at time of abnormality										
200	00010011	High pressure sensor data at time of abnormality	-99.9-999.9 (PSIG)									Display of data from High pressure sensor, all thermistors, and SC/SH at time of abnormality.
201	10010011	TH4 (Compressor) sensor data at time of abnormality										
202	01010011	TH6 (Suction pipe) sensor data at time of abnormality										
203	11010011	TH3 (Outdoor liquid pipe) sensor data at time of abnormality										
204	00110011	TH8 (Heat sink) sensor data at time of abnormality										
205	10110011	OC SC (cooling) at time of abnormality										Display of indoor SC/SH data at time of abnormality
206	01110011	IC1 SC/SH at time of abnormality										
207	11110011	IC2 SC/SH at time of abnormality										
208	00001011	IC3 SC/SH at time of abnormality										
209	10001011	IC4 SC/SH at time of abnormality										
210	01001011	IC5 SC/SH at time of abnormality										Display of indoor unit capacity code The No.1 unit will start from the M-NET address with the lowest number
211	11001011	IC6 Capacity code										
212	00101011	IC7 Capacity code										
213	10101011	IC8 Capacity code										
214	01101011	IC6 operation mode										
215	11101011	IC7 operation mode	Fan	Cooling thermo-ON	Cooling thermo-OFF	Heating thermo-ON	Heating thermo-OFF				Display of indoor unit operation mode	
216	00011011	IC8 operation mode	STOP									

No.	SW1 setting	Display mode	Display on the LED1, 2 (display data)								Notes
			1	2	3	4	5	6	7	8	
217	10011011	IC6 LEV opening pulse	0-2000 (pulse)								Display of opening pulse of indoor LEV
218	01011001	IC7 LEV opening pulse									
219	11011001	IC8 LEV opening pulse									
220	00111011	IC6 TH23 (Gas)									
221	10111011	IC7 TH23 (Gas)									
222	01111011	IC8 TH23 (Gas)									
223	11111011	IC6 TH22 (liquid)									
224	00000111	IC7 TH22 (liquid)	-99.9-999.9 (°F)								Display detected data of indoor unit thermistor
225	10000111	IC8 TH22(liquid)									
226	01000111	IC6 TH21 (intake)									
227	11000111	IC7 TH21 (intake)									
228	00100111	IC8 TH21 (intake)									
229	10100111	IC6 SC/SH									
230	01100111	IC7 SC/SH									
231	11100111	IC8 SC/SH									
232	00010111	Target indoor SC/SH (IC6)									Display of indoor SC/SH data
233	10010111	Target indoor SC/SH (IC7)									
234	01010111	Target indoor SC/SH (IC8)	SCm/SHm (0.0-20.0) (:)								Display of all control target data
235	11010111	IC6 LEV opening pulse abnormality delay									
236	00110111	IC7 LEV opening pulse abnormality delay	0-2000 (pulse)								Display of opening pulse of indoor LEV at time of abnormality delay
237	10110111	IC8 LEV opening pulse abnormality delay									
238	01110111	IC6 SC/SH at time of abnormality delay									
239	11110111	IC7 SC/SH at time of abnormality delay	-99.9-999.9 (:)								Display of indoor SC/SH data at time of abnormality delay
240	00001111	IC8 SC/SH at time of abnormality delay									
241	10001111	IC6 LEV opening pulse at time of abnormality									
242	01001111	IC7 EV opening pulse at time of abnormality									
243	11001111	IC8 LEV opening pulse at time of abnormality	0-2000 (pulse)								Display of opening pulse of indoor LEV at time of abnormality
244	00101111	IC6 SC/SH at time of abnormality									
245	10101111	IC7 SC/SH at time of abnormality	-99.9-999.9 (:)								Display of indoor SC/SH data at time of abnormality delay
246	01101111	IC8 SC/SH at time of abnormality									
250	01011111	IC9 LEV opening pulse									
251	11011111	IC10 LEV opening pulse									
252	00111111	IC11 LEV opening pulse									
253	10111111	IC12 LEV opening pulse	0-2000 (pulse)								Display of opening pulse of indoor LEV

This chapter provides an introduction to electrical wiring for MULTI-S series, together with notes concerning power wiring, wiring for control (transmission wires and remote controller wires), and the frequency converter.

9-1. OVERVIEW OF POWER WIRING

- (1) Use a separate power supply for the outdoor unit and indoor unit.
- (2) Bear in mind ambient conditions (ambient temperature, direct sunlight, rain water, etc.) when proceeding with the wiring and connections.
- (3) The wire size is the minimum value for metal conduit wiring. The power cord size should be 1 rank thicker consideration of voltage drops. Make sure the power-supply voltage does not drop more than 10 %.
- (4) Specific wiring requirements should adhere to the wiring regulations of the region.
- (5) Power supply cords of parts of appliances for outdoor use shall not be lighter than polychloroprene sheathed flexible cord (design 60245 IEC57). For example, use wiring such as YZW.
- (6) Install an earth line longer than power cables.

⚠ Warning:

- Be sure to use specified wires to connect so that no external force is imparted to terminal connections. If connections are not fixed firmly, it may cause heating or fire.
- Be sure to use the appropriate type of overcurrent protection switch. Note that generated overcurrent may include some amount of direct current.

⚠ Caution:

- Some installation site may require attachment of an earth leakage breaker. If no earth leakage breaker is installed, it may cause an electric shock.
- Do not use anything other than breaker and fuse with correct capacity. Using fuse and wire or copper wire with too large capacity may cause a malfunction of unit or fire.
- Be sure to install N-Line. Without N-Line, it could cause damage to the unit.

9-2. WIRING OF MAIN POWER SUPPLY AND EQUIPMENT CAPACITY

9-2-1. Wiring diagram for main power supply

■ Schematic Drawing of Wiring : When NOT using a Branch Box (example)

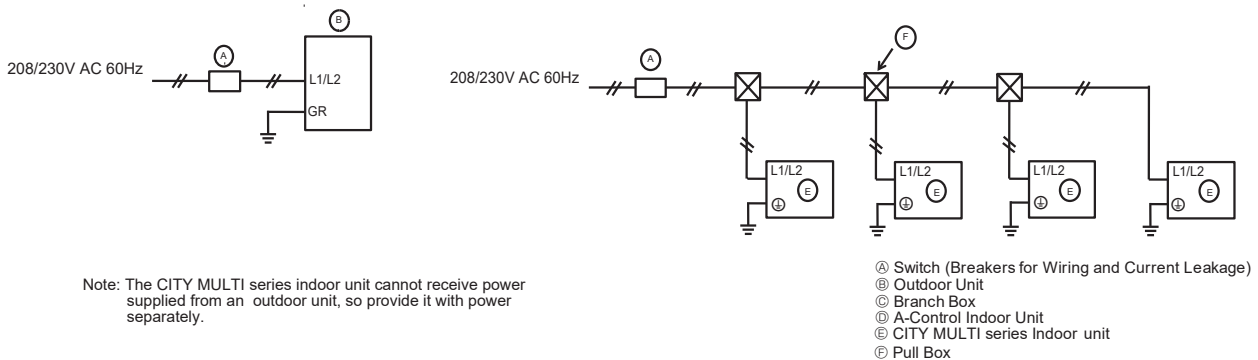

■ Schematic Drawing of Wiring : When using Branch Boxes (example)

<When power is supplied to branch box from the outdoor unit>

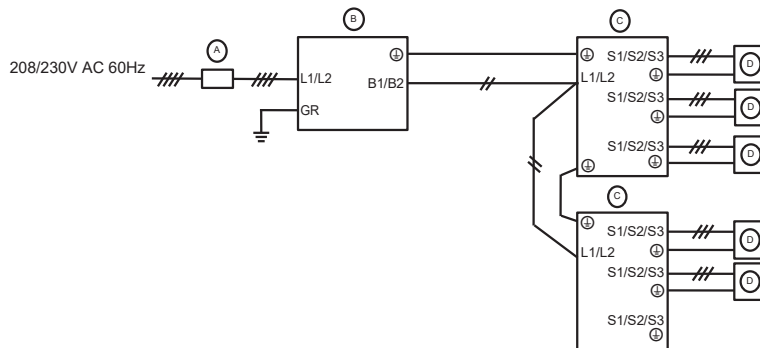

<When power is supplied to outdoor unit and branch box separately>

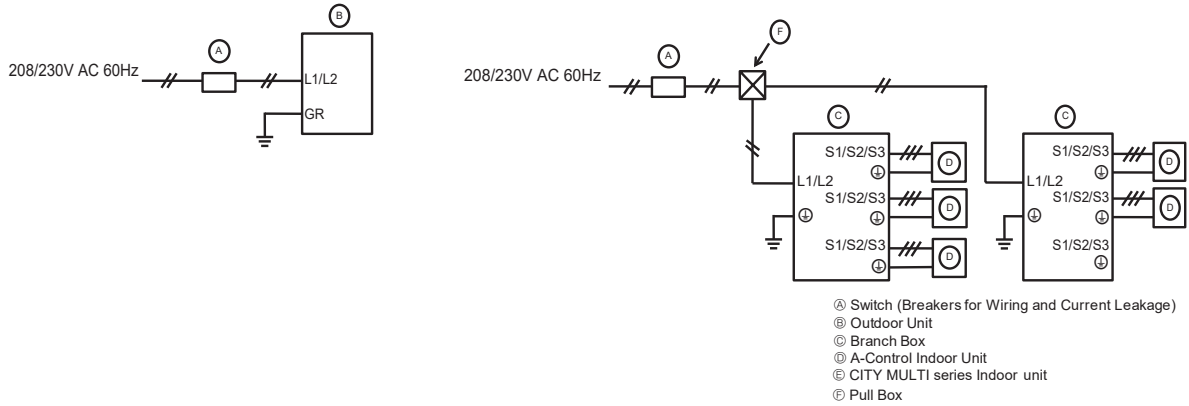

9-2-2. Cross section area of Wire for Main Power and ON/OFF capacities

Thickness of Wire for Main Power Supply and On/Off Capacities

<When power is supplied separately>

Model		Power Supply	Minimum Wire Thickness (mm ² [AWG])		Breaker for Wiring*1	Breaker for Current Leakage (If you use)	Minimum circuit ampacity	Maximum rating of over current protector device
			Main Cable*2	Ground				
Outdoor Unit	36/48NAM	208/230 VAC, 60 Hz	5.3 [AWG10]	5.3 [AWG10]	30 A	30 A, 30 mA 0.1 second or less	29 A	40 A
	36/42/48NAMHZ		8.4 [AWG8]	8.4 [AWG8]	40 A	40 A, 30 mA 0.1 second or less	36 A	40 A
	60NAM		8.4 [AWG8]	8.4 [AWG8]	40 A	40 A, 30 mA 0.1 second or less	36 A	45 A
Branch Box		Refer to installation manual of Branch Box.						

<When power is supplied from the outdoor unit>

Model		Power Supply	Minimum Wire Thickness (mm ² [AWG])		Breaker for Wiring*1	Breaker for Current Leakage (If you use)	Minimum circuit ampacity	Maximum rating of over current protector device
			Main Cable*2	Ground				
Outdoor Unit	36/48NAM	208/230 VAC, 60 Hz	8.4 [AWG8]	8.4 [AWG8]	40 A	40 A, 30 mA 0.1 second or less	35 A	50 A
	36/42/48NAMHZ		13.3 [AWG6]	13.3 [AWG6]	45 A	45 A, 30 mA 0.1 second or less	42 A	50 A
	60NAM		13.3 [AWG6]	13.3 [AWG6]	50 A	50 A, 30 mA 0.1 second or less	46 A	50 A
Branch Box		Refer to installation manual of Branch Box.						

*1 Please follow applicable federal, state, or local codes to prevent potential leakage/electric shock. Or install a ground fault interrupt for the prevention of leakage and electric shock.

IMPORTANT

If a current leakage breaker is used, it should be compatible with higher harmonics as this unit is equipped with an inverter. The use of an inadequate breaker can cause the incorrect operation of inverter.

*2 Use copper supply wires. Use the electric wires over the rating voltage 300 V.

*3 Although the conduit size is larger than the size specified for the wire thickness according to UL standards, use a conduit size of 3/4 inch.

Total operating current of the indoor unit	Minimum wire thickness (mm ² /AWG)			Ground-fault interrupter *1 (If you use)	Local switch (A)		Breaker for wiring (NFB)
	Main Cable	Branch	Ground		Capacity	Fuse	
F0 = 15 A or less *2	2.1/14	2.1/14	2.1/14	15 A current sensitivity *3	15	15	15
F0 = 20 A or less *2	3.3/12	3.3/12	3.3/12	20 A current sensitivity *3	20	20	20
F0 = 30 A or less *2	5.3/10	5.3/10	5.3/10	30 A current sensitivity *3	30	30	30

Apply to IEC61000-3-3 about max. permissive system impedance.

*1The Ground-fault interrupter should support inverter circuit.

The Ground-fault interrupter should combine using of local switch or wiring breaker.

*2Please take the larger of F1 or F2 as the value for F0.

F1 = Total operating maximum current of the indoor units × 1.2

F2 = {V1 × (Quantity of Type1)/C} + {V1 × (Quantity of Type2)/C} + {V1 × (Quantity of Type3)/C} + ... + {V1 × (Quantity of Type13)/C}

Indoor unit		V1	V2
Type 1	PEAD-A·AA, SVZ-A·AA	26.9	2.4
Type 2	PLA-A·EA7, SEZ-KD·NA	19.8	
Type 3	SLZ-KF·NA	17.1	
Type 4	MLZ-KP·NA(2)	9.9	
Type 5	MFZ-KJ·NA, MSZ-GL·NA, MSZ-FS·NA	7.4	
Type 6	MSZ-FH·NA, MSZ-FH·NA2, MSZ-EF·NAW(B)(S)-U1	6.8	
Type 7	Branch box	5.1	3.0
Type 8	PEFY-P·NMAU-E3, PVFY-P·NAMU	38.0	1.6
Type 9	PKFY-P·NHMU, PKFY-P·NKMU, PEFY-P·NMSU, PCFY-P·NKMU, PLFY-EP·NEMU, PLFY-P·NFMU, PMFY-P·NBMU, PKFY-P·NLMU	19.8	2.4
Type 10	PKFY-P·NBMU, PLFY-P·NCMU	3.5	2.4
Type 11	PEFY-P·NMHU, PFFY-P·NEMU, PFFY-P·NRMU	0.0	0.0
Type 12	PEFY-P·NMHSU (connected to MXZ-SM60 only)	13.8	4.8
Type 13	PEFY-P·NMAU-E4	18.6	3.0

C: Multiple of tripping current at tripping time 0.01s

Please pick up "C" from the tripping characteristic of the breaker.

<Example of "F2" calculation>

• Condition PEFY-NMSU × 4 + PEFY-NMAU × 1, C = 8 (refer to right sample chart)

F2 = 19.8 × 4/8 + 38 × 1/8

= 14.65

→ 16 A breaker (Tripping current = 8 × 16 A at 0.01 s)

*3Current sensitivity is calculated using the following formula.

G1 = V2 × (Quantity of Type1) + V2 × (Quantity of Type2) + V2 × (Quantity of Type3) + ... + V2 × (Quantity of Type13) + V3 × (Wire length [km])

G1	Current sensitivity
30 or less	30 mA 0.1 second or less
100 or less	100 mA 0.1 second or less

Wire thickness (mm ² /AWG)	V3
2.1/14	48
3.3/12	56
5.3/10	66

Sample chart

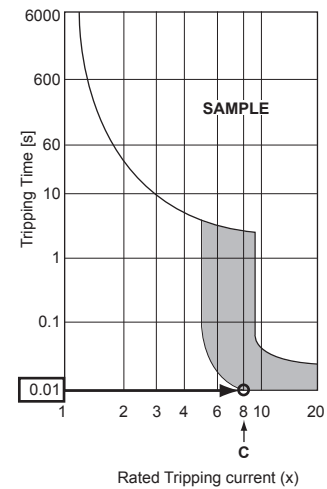

1. Use a separate power supply for the outdoor unit and indoor unit.
2. Bear in mind ambient conditions (ambient temperature, direct sunlight, rain water etc.) when proceeding with the wiring and connections.
3. The wire size is the minimum value for metal conduit wiring. The power cord size should be 1 rank thicker consideration of voltage drops. Make sure the power-supply voltage does not drop more than 10%.
4. Specific wiring requirements should adhere to the wiring regulations of the region.
5. Power supply cords of parts of appliances for outdoor use shall not be lighter than polychloroprene sheathed flexible cord (design 60245 IEC57). For example, use wiring such as YZW.
6. Install an earth line longer than power cables.

9-3. DESIGN FOR CONTROL WIRING

Please note that the types and numbers of control wires needed by MULTI-S series depend on the remote controllers and whether they are linked with the system or not.

9-3-1. Selection number of control wires

		M-NET remote controller
Use		Remote controller used in system control operations <ul style="list-style-type: none"> • Group operation involving different refrigerant systems • Linked operation with upper control system
Remote controller → indoor unit		2-core wire (non-polar)
Transmission wires	Wires connecting → indoor units	
	Wires connecting → indoor units with outdoor unit	
	Wires connecting → outdoor units	

9-4. WIRING TRANSMISSION CABLES

9-4-1. Types of control cables

1. Wiring transmission cables

Types of transmission cables	Shielding wire CVVS, CPEVS, or MVVS
Cable diameter	More than 13.5 ft ² [1.25 mm ²]
Maximum wiring length	Within 656 ft [200 m]

2. M-NET Remote control cables

Types of remote control cable	Shielding wire (2-core) CVVS, CPEVS, or MVVS
Cable diameter	AWG 20 to AWG 16 [0.5 to 1.25 mm ²]
Remarks	When 10 m is exceeded, use a cable with the same specifications as transmission line wiring.

3. MA Remote control cables

Type of remote control cable	Sheathed 2-core cable (unshielded) CVV
Cable diameter	AWG 22 to AWG 16 [0.3 to 1.25 mm ²] AWG 18 to AWG 16 [0.75 to 1.25 mm ²]*
Remarks	Within 656 ft [200 m]

* Connected with simple remote controller.

9-4-2. Wiring examples

- Controller name, symbol and allowable number of controllers.

Name		Symbol	Allowable number of controllers	
Outdoor unit controller		OC	—	
Indoor unit controller	CITY MULTI series	M-IC	SM36	Refer to 2-2. SYSTEM CONSTRUCTION
			SM42/48/60	
	M, S, P series	A-IC	SM36	
			SM42	
SM48				
SM60				
Branch box		BC	—	0 to 2 units per 1 OC ^{*1}
Remote controller		RC	M-NET RC ^{*2}	Maximum of 12 controllers for 1 OC ^{*1}
			MA-RC	Maximum of 2 per group

Note:

^{*1} The number of connectable units may be limited by some conditions such as an indoor unit's capacity or each unit's equivalent power consumption.

^{*2} Don't use the Lossnay controller (PZ-61DR-E, PZ-43SMF-E, PZ-52SF-E, PZ-60DR-E).

9-5. SYSTEM SWITCH SETTING

In order to identify the destinations of signals to the outdoor units, indoor units, and remote controller of MULTI-S series, each microprocessor must be assigned an identification number (address). The addresses of outdoor units, indoor units, and remote controller must be set using their settings switches. Please consult the installation manual that comes with each unit for detailed information on setting procedures.

9-6. EXAMPLE EXTERNAL WIRING DIAGRAM FOR A BASIC SYSTEM

- Example of system when using an M-NET controller

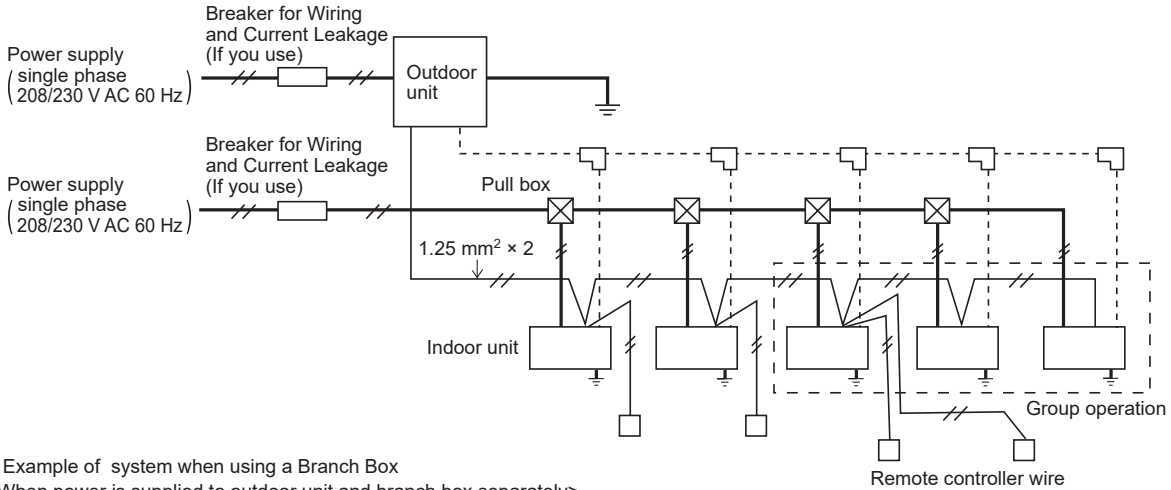

- Example of system when using a Branch Box

<When power is supplied to outdoor unit and branch box separately>

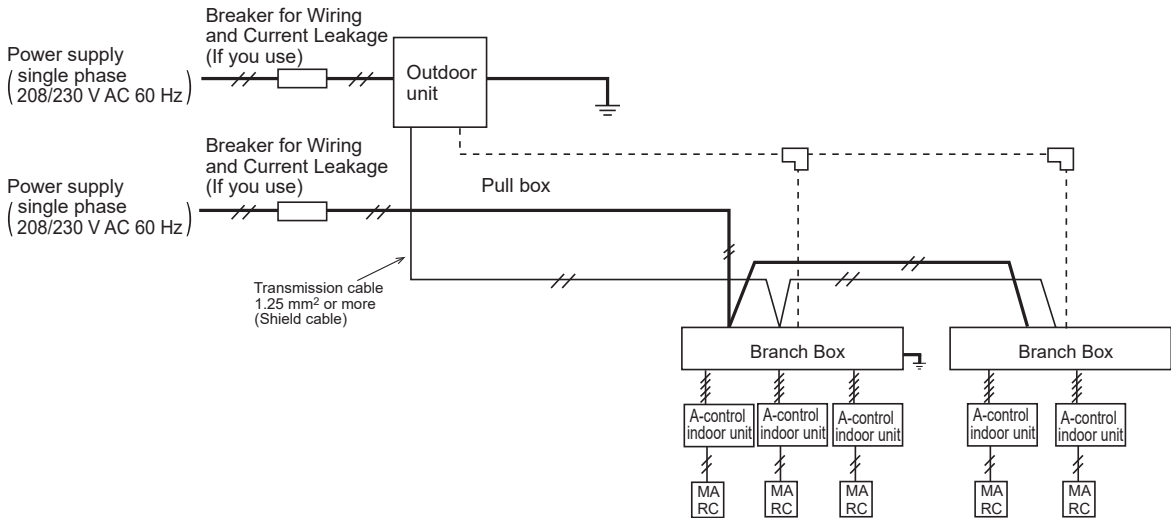

<When power is supplied to branch box from the outdoor unit>

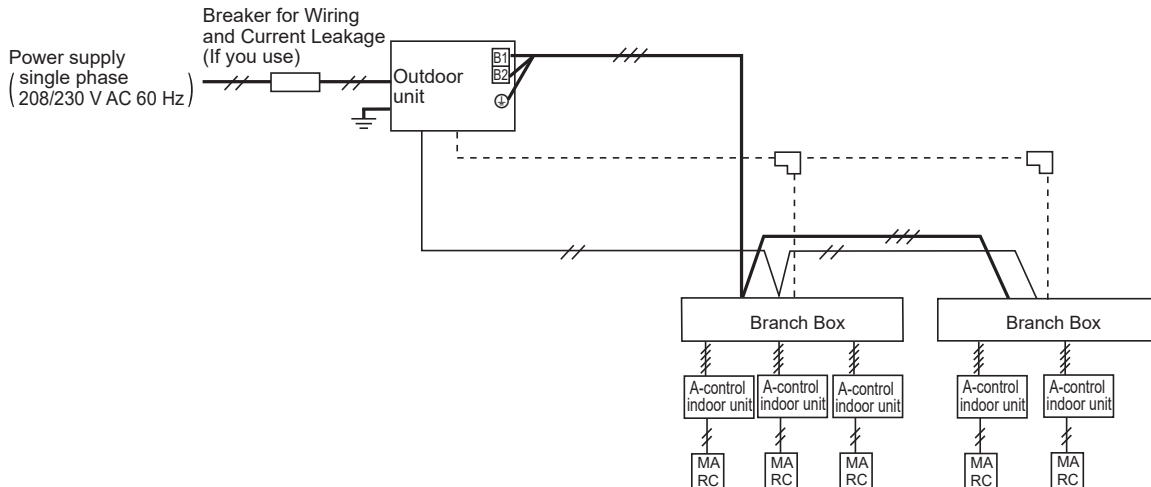

9-7. METHOD FOR OBTAINING ELECTRICAL CHARACTERISTICS WHEN A CAPACITY AGREEMENT IS TO BE SIGNED WITH AN ELECTRIC POWER COMPANY

The electrical characteristics of connected indoor unit system for air conditioning systems, including CITY MULTI series, depend on the arrangement of the indoor and outdoor units.

First read the data on the selected indoor and outdoor units and then use the following formulas to calculate the electrical characteristics before applying for a capacity agreement with the local electric power company.

9-7-1. Obtaining the electrical characteristics of CITY MULTI series system

(1) Procedure for obtaining total power consumption

	Page numbers in this technical manual	Power consumption
Total power consumption of each indoor unit	See the technical manual of each indoor unit.	1
Power consumption of outdoor unit*	Standard capacity diagram— Refer to 4-4.	2
Total power consumption of system	See the technical manual of each indoor unit.	1+2 <kW>

*The power consumption of the outdoor unit will vary depending on the total capacity of the selected indoor units.

(2) Method of obtaining total current

	Page numbers in this technical manual	Subtotal
Total current through each indoor unit	See the technical manual of each indoor unit.	1
Current through outdoor unit*	Standard capacity diagram— Refer to 4-4.	2
Total current through system	See the technical manual of each indoor unit.	1+2 <A>

The current through the outdoor unit will vary depending on the total capacity of the selected indoor units.

(3) Method of obtaining system power factor

Use the following formula and the total power and current obtained in parts 1 and 2 on the above tables to calculate the system power factor.

$$\text{System power factor} = \frac{(\text{Total system power consumption})}{(\text{Total system current} \times \text{voltage})} \times 100 \%$$

9-7-2. Applying to an electric power company for power and total current

Calculations should be performed separately for heating and cooling employing the same methods; use the largest resulting value in your application to the electric power company.

10-1. REFRIGERANT PIPING SYSTEM

- 10-1-1. MXZ-SM36NAM-U1 MXZ-SM36NAMHZ-U1
 MXZ-SM42NAMHZ-U1
 MXZ-SM48NAM-U1 MXZ-SM48NAMHZ-U1

Line-Branch Method
 Connection Examples
 (Connecting to 4 Indoor Units)

Permissible Length	Total Piping Length	$A+B+C+a+b+c+d \leq 984$ ft [300 meters]																				
	Farthest Piping Length (L)	$A+B+C+d \leq 492$ ft [150 meters]																				
	Farthest Piping Length After First Branch (ℓ)	$B+C+d \leq 98$ ft [30 meters]																				
Permissible High/Low Difference	High/Low Difference in Indoor/Outdoor Section (H)	The outdoor unit is upper: 164ft [50m] or less The outdoor unit is lower: 131ft [40m] or less (98ft [30.] or less if PKFY-P06NBMU, PKFY-P08NHMU, PKFY-P04/06/08/12NLMU, PFFY-P06/08/12NEMU, and PFFY-P06/08/12NRMU are included.)																				
	High/Low Difference in Indoor/Indoor Section (h)	49 ft [15 meters]																				
<p>■ Selecting the Refrigerant Branch Kit</p> <p>■ Select Each Section of Refrigerant Piping</p> <p>(1) Section From Outdoor Unit to First Branch (A) (2) Sections From Branch to Indoor Unit (a,b,c,d) (3) Section From Branch to Branch (B,C)</p> <p style="text-align: right;">} Each Section of Piping</p> <p>Select the size from the table to the right.</p>		<p>Use an optional branch piping kit (CMY-Y62-G-E).</p> <p>(1) Refrigerant Piping Diameter In Section From Outdoor Unit to First Branch (Outdoor Unit Piping Diameter)</p> <table border="1" style="width: 100%; border-collapse: collapse;"> <thead> <tr> <th>Model</th> <th>Piping Diameter (inch [mm])</th> </tr> </thead> <tbody> <tr> <td rowspan="2">MXZ-SM36/42/48</td> <td>Liquid Line 3/8 [ø9.52]</td> </tr> <tr> <td>Gas Line 5/8 [ø15.88]</td> </tr> </tbody> </table> <p>(2) Refrigerant Piping Diameter In Section From Branch to Indoor Unit (Indoor Unit Piping Diameter)</p> <table border="1" style="width: 100%; border-collapse: collapse;"> <thead> <tr> <th>Model number</th> <th>Piping Diameter (inch [mm])</th> </tr> </thead> <tbody> <tr> <td rowspan="2">- 18</td> <td>Liquid Line 1/4 [ø6.35]</td> </tr> <tr> <td>Gas Line 1/2 [ø12.7]</td> </tr> <tr> <td rowspan="2">24 - 54</td> <td>Liquid Line 3/8 [ø9.52]</td> </tr> <tr> <td>Gas Line 5/8 [ø15.88]</td> </tr> </tbody> </table> <p>(3) Refrigerant Piping Diameter In Section From Branch to Branch</p> <table border="1" style="width: 100%; border-collapse: collapse;"> <thead> <tr> <th>Liquid Line (inch [mm])</th> <th>Gas Line (inch [mm])</th> </tr> </thead> <tbody> <tr> <td>3/8 [ø9.52]</td> <td>5/8 [ø15.88]</td> </tr> </tbody> </table>	Model	Piping Diameter (inch [mm])	MXZ-SM36/42/48	Liquid Line 3/8 [ø9.52]	Gas Line 5/8 [ø15.88]	Model number	Piping Diameter (inch [mm])	- 18	Liquid Line 1/4 [ø6.35]	Gas Line 1/2 [ø12.7]	24 - 54	Liquid Line 3/8 [ø9.52]	Gas Line 5/8 [ø15.88]	Liquid Line (inch [mm])	Gas Line (inch [mm])	3/8 [ø9.52]	5/8 [ø15.88]			
Model	Piping Diameter (inch [mm])																					
MXZ-SM36/42/48	Liquid Line 3/8 [ø9.52]																					
	Gas Line 5/8 [ø15.88]																					
Model number	Piping Diameter (inch [mm])																					
- 18	Liquid Line 1/4 [ø6.35]																					
	Gas Line 1/2 [ø12.7]																					
24 - 54	Liquid Line 3/8 [ø9.52]																					
	Gas Line 5/8 [ø15.88]																					
Liquid Line (inch [mm])	Gas Line (inch [mm])																					
3/8 [ø9.52]	5/8 [ø15.88]																					
<p>■ Additional refrigerant charge</p> <p>Refrigerant for the extended piping is not included in the outdoor unit when the unit is shipped from the factory. Therefore, charge each refrigerant piping system with additional refrigerant at the installation site. In addition, in order to carry out service, enter the size and length of each liquid pipe and additional refrigerant charge amounts in the spaces provided on the "Refrigerant amount" plate on the outdoor unit.</p> <p>Calculation of additional refrigerant charge</p> <ul style="list-style-type: none"> Calculate the additional charge using the liquid pipe size and length of the extended piping and total capacity of connected indoor units. Calculate the additional refrigerant charge using the procedure shown to the right, and charge with the additional refrigerant. For amounts less than 0.2 lb [0.1 kg], round up the calculated additional refrigerant charge. (For example, if the calculated charge is 13.2 lb [6.01 kg], round up the charge to 13.4 lb [6.1 kg].) 		<p><Additional Charge></p> <p>Calculation of refrigerant charge</p> <table border="1" style="width: 100%; border-collapse: collapse;"> <tr> <td>Pipe size Liquid pipe ø6.35</td> <td>+</td> <td>Pipe size Liquid pipe ø9.52</td> <td>+</td> <td>Total capacity of connected indoor units - 27 kBTu/h</td> <td>Amount for the indoor units 53 oz (1.5 kg)</td> </tr> <tr> <td>$[ft] \times 0.21 [oz/ft]$ $(m) \times 19.0 (g/m)$</td> <td></td> <td>$[ft] \times 0.55 [oz/ft]$ $(m) \times 50.0 (g/m)$</td> <td></td> <td>28 - 54 kBTu/h</td> <td>88 oz (2.5 kg)</td> </tr> <tr> <td></td> <td></td> <td></td> <td></td> <td>55 - 62 kBTu/h</td> <td>106 oz (3.0 kg)</td> </tr> </table> <p>Included refrigerant amount when shipped from the factory</p> <table border="1" style="width: 100%; border-collapse: collapse;"> <tr> <td>Included refrigerant amount</td> </tr> <tr> <td>10 LBS. 9 OZ. (4.8 kg)</td> </tr> </table> <p><Example></p> <p>Outdoor model : SM48 Indoor 1 : P24 (24 kBTu/h) 2 : P15 (15 kBTu/h) 3 : P08 (8 kBTu/h) 4 : P06 (6 kBTu/h)</p> <p>A : ø9.52 66 ft [20 m] B : ø9.52 16 ft [5 m] C : ø9.52 16 ft [5 m] a : ø9.52 49 ft [15 m] b : ø6.35 33 ft [10 m] c : ø6.35 33 ft [10 m] d : ø6.35 66 ft [20 m]</p> <p style="text-align: right;">} At the conditions below:</p> <p>The total length of each liquid line is as follows: [3/8"] ø9.52 : A + B + C + a = 20 + 5 + 5 + 15 = 147 ft [45 m] [1/4"] ø6.35 : b + c + d = 10 + 10 + 20 = 132 ft [40 m] The total capacity of connected indoor unit is as follows: 24 + 15 + 08 + 06 = 53</p> <p><Calculation example></p> <p>Additional refrigerant charge 132 ft × 0.21 oz + 147 ft × 0.55 oz + 88 oz = 197 oz $\left[40 \times \frac{19.0}{1000} + 45 \times \frac{50.0}{1000} + 2.5 = 5.6 \text{ kg (rounded up)}\right]$</p>	Pipe size Liquid pipe ø6.35	+	Pipe size Liquid pipe ø9.52	+	Total capacity of connected indoor units - 27 kBTu/h	Amount for the indoor units 53 oz (1.5 kg)	$[ft] \times 0.21 [oz/ft]$ $(m) \times 19.0 (g/m)$		$[ft] \times 0.55 [oz/ft]$ $(m) \times 50.0 (g/m)$		28 - 54 kBTu/h	88 oz (2.5 kg)					55 - 62 kBTu/h	106 oz (3.0 kg)	Included refrigerant amount	10 LBS. 9 OZ. (4.8 kg)
Pipe size Liquid pipe ø6.35	+	Pipe size Liquid pipe ø9.52	+	Total capacity of connected indoor units - 27 kBTu/h	Amount for the indoor units 53 oz (1.5 kg)																	
$[ft] \times 0.21 [oz/ft]$ $(m) \times 19.0 (g/m)$		$[ft] \times 0.55 [oz/ft]$ $(m) \times 50.0 (g/m)$		28 - 54 kBTu/h	88 oz (2.5 kg)																	
				55 - 62 kBTu/h	106 oz (3.0 kg)																	
Included refrigerant amount																						
10 LBS. 9 OZ. (4.8 kg)																						

Header-Branch Method
Connection Examples
(Connecting to 4 Indoor Units)

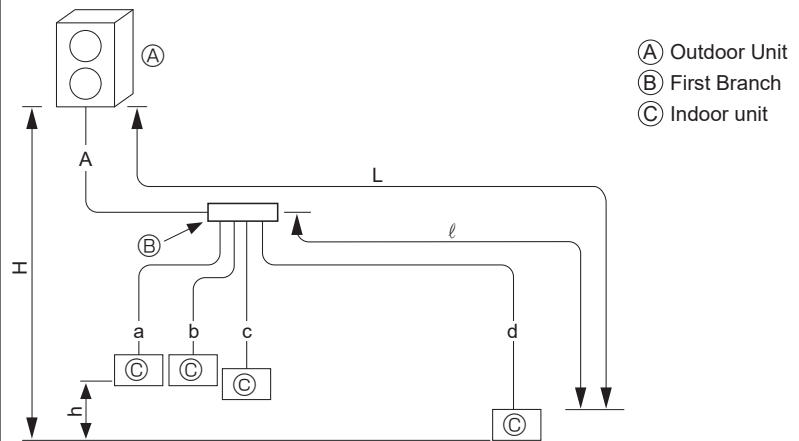

Permissible Length	Total Piping Length	$A+a+b+c+d \leq 984 \text{ ft [300 meters]}$																												
	Farthest Piping Length (L)	$A+d \leq 492 \text{ ft [150 meters]}$																												
	Farthest Piping Length After First Branch (ℓ)	d is 98 ft [30 meters]																												
Permissible High/Low Difference	High/Low Difference in Indoor/Outdoor Section (H)	The outdoor unit is upper: 164ft [50m] or less The outdoor unit is lower: 131ft [40m] or less (98ft [30.] or less if PKFY-P06NBMU, PKFY-P08NHMU, PKFY-P04/06/08/12NLMU, PFFY-P06/08/12NEMU, and PFFY-P06/08/12NRMU are included.)																												
	High/Low Difference in Indoor/Indoor Section (h)	49 ft [15 meters]																												
■ Selecting the Refrigerant Branch Kit Please select branching kit, which is sold separately, from the table below. (The kit comprises sets for use with liquid pipes and for use with gas pipes.)		<table border="1" style="width: 100%; text-align: center;"> <tr> <td>Branch header (4 branches)</td> <td>Branch header (8 branches)</td> </tr> <tr> <td>CMY-Y64-G-E</td> <td>CMY-Y68-G-E</td> </tr> </table>		Branch header (4 branches)	Branch header (8 branches)	CMY-Y64-G-E	CMY-Y68-G-E																							
Branch header (4 branches)	Branch header (8 branches)																													
CMY-Y64-G-E	CMY-Y68-G-E																													
■ Select Each Section of Refrigerant Piping (1) Section From Outdoor Unit to First Branch (A) (2) Sections From Branch to Indoor Unit (a,b,c,d) Each Section of Piping Select the size from the table to the right.		<table border="1" style="width: 100%;"> <tr> <th colspan="2">(1) Refrigerant Piping Diameter In Section From Outdoor Unit to First Branch (Outdoor Unit Piping Diameter)</th> <th colspan="2">(2) Refrigerant Piping Diameter In Section From Branch to Indoor Unit (Indoor Unit Piping Diameter)</th> </tr> <tr> <th>Model</th> <th>Piping Diameter (inch [mm])</th> <th>Model number</th> <th>Piping Diameter (inch [mm])</th> </tr> <tr> <td rowspan="4">MXZ-SM36/42/48</td> <td>Liquid Line</td> <td rowspan="2">- 18</td> <td>Liquid Line</td> <td>1/4 [ø6.35]</td> </tr> <tr> <td>Gas Line</td> <td>Gas Line</td> <td>1/2 [ø12.7]</td> </tr> <tr> <td rowspan="2">Liquid Line</td> <td rowspan="2">3/8 [ø9.52]</td> <td rowspan="2">24 - 54</td> <td>Liquid Line</td> <td>3/8 [ø9.52]</td> </tr> <tr> <td>Gas Line</td> <td>5/8 [ø15.88]</td> </tr> </table> (3) Refrigerant Piping Diameter In Section From Branch to Branch <table border="1" style="width: 100%; text-align: center;"> <tr> <th>Liquid Line (inch [mm])</th> <th>Gas Line (inch [mm])</th> </tr> <tr> <td>3/8 [ø9.52]</td> <td>5/8 [ø15.88]</td> </tr> </table>		(1) Refrigerant Piping Diameter In Section From Outdoor Unit to First Branch (Outdoor Unit Piping Diameter)		(2) Refrigerant Piping Diameter In Section From Branch to Indoor Unit (Indoor Unit Piping Diameter)		Model	Piping Diameter (inch [mm])	Model number	Piping Diameter (inch [mm])	MXZ-SM36/42/48	Liquid Line	- 18	Liquid Line	1/4 [ø6.35]	Gas Line	Gas Line	1/2 [ø12.7]	Liquid Line	3/8 [ø9.52]	24 - 54	Liquid Line	3/8 [ø9.52]	Gas Line	5/8 [ø15.88]	Liquid Line (inch [mm])	Gas Line (inch [mm])	3/8 [ø9.52]	5/8 [ø15.88]
(1) Refrigerant Piping Diameter In Section From Outdoor Unit to First Branch (Outdoor Unit Piping Diameter)		(2) Refrigerant Piping Diameter In Section From Branch to Indoor Unit (Indoor Unit Piping Diameter)																												
Model	Piping Diameter (inch [mm])	Model number	Piping Diameter (inch [mm])																											
MXZ-SM36/42/48	Liquid Line	- 18	Liquid Line	1/4 [ø6.35]																										
	Gas Line		Gas Line	1/2 [ø12.7]																										
	Liquid Line	3/8 [ø9.52]	24 - 54	Liquid Line	3/8 [ø9.52]																									
				Gas Line	5/8 [ø15.88]																									
Liquid Line (inch [mm])	Gas Line (inch [mm])																													
3/8 [ø9.52]	5/8 [ø15.88]																													
■ Additional refrigerant charge		Refer to the same section in the previous page.																												

Method of Combined Branching of Lines and Headers

Connection Examples
(Connecting to 5 Indoor Units)

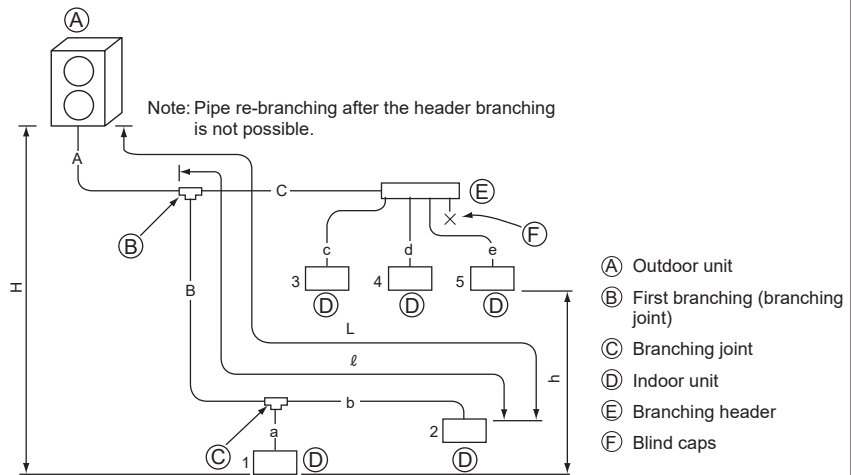

Permissible Length	Total Piping Length	A+B+C+a+b+c+d+e is 984 ft [300 meters]
	Farthest Piping Length (L)	A+B+b is 492 ft [150 meters]
	Farthest Piping Length After First Branch (ℓ)	B+b is 98 tf [30 meters]
Permissible High/Low Difference	High/Low Difference in Indoor/Outdoor Section (H)	The outdoor unit is upper: 164ft [50m] or less The outdoor unit is lower: 131ft [40m] or less (98ft [30.] or less if PKFY-P06NBMU, PKFY-P08NHMU, PKFY-P04/06/08/12NLMU, PFFY-P06/08/12NEMU, and PFFY-P06/08/12NRMU are included.)
	High/Low Difference in Indoor/Indoor Section (h)	49 ft [15 meters]

■ **Selecting the Refrigerant Branch Kit**

Please select branching kit, which is sold separately, from the table below.
(The kit comprises sets for use with liquid pipes and for use with gas pipes.)

Branch Joint	Branch Header (4 branches)	Branch Header (8 branches)
CMY-Y62-G-E	CMY-Y64-G-E	CMY-Y68-G-E

■ **Select Each Section of Refrigerant Piping**

(1) Section From Outdoor Unit to First Branch (A)
(2) Sections From Branch to Indoor Unit (a,b,c,d,e)
(3) Section From Branch to Branch (B,C)

Each Section of Piping

Select the size from the table to the right.

(1) Refrigerant Piping Diameter In Section From Outdoor Unit to First Branch (Outdoor Unit Piping Diameter)			(2) Refrigerant Piping Diameter In Section From Branch to Indoor Unit (Indoor Unit Piping Diameter)		
Model	Piping Diameter (inch [mm])		Model number	Piping Diameter(inch [mm])	
MXZ-SM36/42/48	Liquid Line	3/8 [ø9.52]	- 18	Liquid Line	1/4 [ø6.35]
	Gas Line	5/8 [ø15.88]		Gas Line	1/2 [ø12.7]
	Liquid Line	3/8 [ø9.52]	24 - 54	Liquid Line	3/8 [ø9.52]
	Gas Line	5/8 [ø15.88]		Gas Line	5/8 [ø15.88]

(3) Refrigerant Piping Diameter In Section From Branch to Branch

Liquid Line (inch [mm])	Gas Line (inch [mm])
3/8 [ø9.52]	5/8 [ø15.88]

■ **Additional refrigerant charge**

Refer to the same section in the previous page.

10-1-2. MXZ-SM60NAM-U1

Line-Branch Method
Connection Examples
(Connecting to 4 Indoor Units)

(A) Outdoor Unit
 (B) First Branch
 (C) Indoor unit

Permissible Length	Total Piping Length	A+B+C+a+b+c+d ≤ 492 ft [150 meters]
	Farthest Piping Length (L)	A+B+C+d ≤ 262 ft [80 meters]
	Farthest Piping Length After First Branch (l)	B+C+d ≤ 98 ft [30 meters]
Permissible High/Low Difference	High/Low Difference in Indoor/Outdoor Section (H)	164 ft [50 meters] (If the outdoor unit is lower, 131 ft [40 meters])
	High/Low Difference in Indoor/Indoor Section (h)	49 ft [15 meters]

■ Selecting the Refrigerant Branch Kit
Use an optional branch piping kit (CMY-Y62-G-E).

■ Select Each Section of Refrigerant Piping

(1) Section From Outdoor Unit to First Branch (A)

(2) Sections From Branch to Indoor Unit (a,b,c,d)

(3) Section From Branch to Branch (B,C)

Select the size from the table to the right.

Each Section of Piping

(1) Refrigerant Piping Diameter In Section From Outdoor Unit to First Branch (Outdoor Unit Piping Diameter)

Model	Piping Diameter (inch[mm])
MXZ-SM60	Liquid Line 3/8 [ø9.52]
	Gas Line 3/4 [ø19.05]

(2) Refrigerant Piping Diameter In Section From Branch to Indoor Unit (Indoor Unit Piping Diameter)

Model number	Piping Diameter (inch[mm])
- 18	Liquid Line 1/4 [ø6.35]
	Gas Line 1/2 [ø12.7]
24 - 54	Liquid Line 3/8 [ø9.52]
	Gas Line 5/8 [ø15.88]
72	Liquid Line 3/8 [ø9.52]
	Gas Line 3/4 [ø19.05]

(3) Refrigerant Piping Diameter In Section From Branch to Branch

Liquid Line (inch[mm])	Gas Line (inch[mm])
3/8 [ø9.52]	3/4 [ø19.05]

■ Additional refrigerant charge
Refrigerant for the extended piping is not included in the outdoor unit when the unit is shipped from the factory. Therefore, charge each refrigerant piping system with additional refrigerant at the installation site. In addition, in order to carry out service, enter the size and length of each liquid pipe and additional refrigerant charge amounts in the spaces provided on the "Refrigerant amount" plate on the outdoor unit.

Calculation of additional refrigerant charge

- Calculate the additional charge using the liquid pipe size and length of the extended piping and total capacity of connected indoor units.
- Calculate the additional refrigerant charge using the procedure shown to the right, and charge with the additional refrigerant.
- For amounts less than 0.2 lb [0.1 kg], round up the calculated additional refrigerant charge. (For example, if the calculated charge is 13.2 lb [6.01 kg], round up the charge to 13.4 lb [6.1 kg].)

<Additional Charge>

Calculation of refrigerant charge

<table border="1" style="width: 100%; border-collapse: collapse;"> <tr> <th>Pipe size</th> <th>Liquid pipe</th> </tr> <tr> <td>ø6.35</td> <td>[ft] × 0.29 [oz/ft] [m] × 27.0 (g/m)</td> </tr> </table>	Pipe size	Liquid pipe	ø6.35	[ft] × 0.29 [oz/ft] [m] × 27.0 (g/m)	+	<table border="1" style="width: 100%; border-collapse: collapse;"> <tr> <th>Pipe size</th> <th>Liquid pipe</th> </tr> <tr> <td>ø9.52</td> <td>[ft] × 0.75 [oz/ft] [m] × 70.0 (g/m)</td> </tr> </table>	Pipe size	Liquid pipe	ø9.52	[ft] × 0.75 [oz/ft] [m] × 70.0 (g/m)	+	<table border="1" style="width: 100%; border-collapse: collapse;"> <tr> <th>Total capacity of connected indoor units</th> <th>Amount for the indoor units</th> </tr> <tr> <td>- 27 kBtu/h</td> <td>53 oz (1.5 kg)</td> </tr> <tr> <td>28 - 54 kBtu/h</td> <td>88 oz (2.5 kg)</td> </tr> <tr> <td>55 - 78 kBtu/h</td> <td>106 oz (3.0 kg)</td> </tr> </table>	Total capacity of connected indoor units	Amount for the indoor units	- 27 kBtu/h	53 oz (1.5 kg)	28 - 54 kBtu/h	88 oz (2.5 kg)	55 - 78 kBtu/h	106 oz (3.0 kg)
Pipe size	Liquid pipe																			
ø6.35	[ft] × 0.29 [oz/ft] [m] × 27.0 (g/m)																			
Pipe size	Liquid pipe																			
ø9.52	[ft] × 0.75 [oz/ft] [m] × 70.0 (g/m)																			
Total capacity of connected indoor units	Amount for the indoor units																			
- 27 kBtu/h	53 oz (1.5 kg)																			
28 - 54 kBtu/h	88 oz (2.5 kg)																			
55 - 78 kBtu/h	106 oz (3.0 kg)																			

Included refrigerant amount when shipped from the factory

Included refrigerant amount
11 LBS. 4 OZ. (5.1 kg)

<Example>
Outdoor model : P60
Indoor 1 : P24 (24 kBtu/h)
2 : P15 (15 kBtu/h)
3 : P08 (8 kBtu/h)
4 : P06 (6 kBtu/h)

A : ø9.52 66 ft [20 m]
B : ø9.52 16 ft [5 m]
C : ø9.52 16 ft [5 m]
a : ø9.52 49 ft [15 m]
b : ø6.35 33 ft [10 m]
c : ø6.35 33 ft [10 m]
d : ø6.35 66 ft [20 m]

At the conditions below:

The total length of each liquid line is as follows:
[3/8"] ø9.52 : A + B + C + a = 20 + 5 + 5 + 15 = 147 ft [45 m]
[1/4"] ø6.35 : b + c + d = 10 + 10 + 20 = 132 ft [40 m]
The total capacity of connected indoor unit is as follows:
24 + 15 + 08 + 06 = 53
<Calculation example>
Additional refrigerant charge
132 ft × 0.29 oz + 147 ft × 0.75 oz + 88 oz = 237 oz [40 × $\frac{27.0}{1000}$ + 45 × $\frac{70.0}{1000}$ + 2.5 = 6.8 kg (rounded up)]

Header-Branch Method
Connection Examples
 (Connecting to 4 Indoor Units)

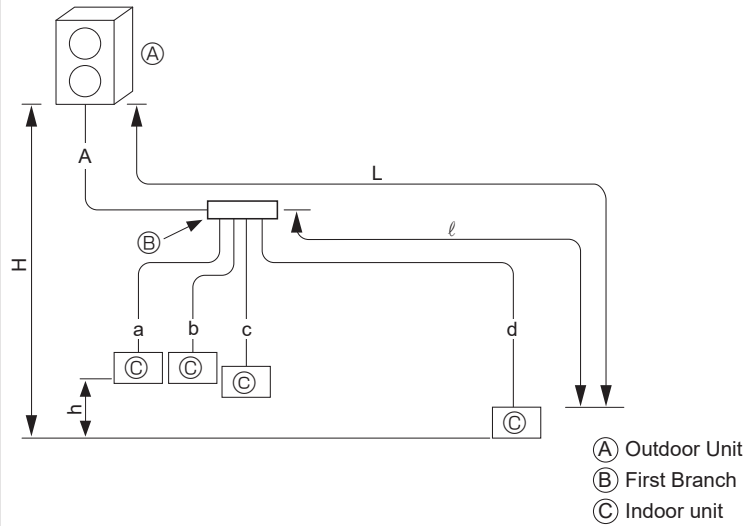

Permissible Length	Total Piping Length	$A+a+b+c+d \leq 492$ ft [150 meters]																											
	Farthest Piping Length (L)	$A+d \leq 262$ ft [80 meters]																											
	Farthest Piping Length After First Branch (l)	d is 100 ft [30 meters]																											
Permissible High/Low Difference	High/Low Difference in Indoor/Outdoor Section (H)	164 ft [50 meters] (If the outdoor unit is lower, 131 ft [40 meters])																											
	High/Low Difference in Indoor/Indoor Section (h)	49 ft [15 meters]																											
<p>■ Selecting the Refrigerant Branch Kit</p> <p>Please select branching kit, which is sold separately, from the table below. (The kit comprises sets for use with liquid pipes and for use with gas pipes.)</p> <table border="1" style="margin-left: auto; margin-right: auto;"> <tr> <td>Branch header (4 branches)</td> <td>Branch header (8 branches)</td> </tr> <tr> <td>CMY-Y64-G-E</td> <td>CMY-Y68-G-E</td> </tr> </table>		Branch header (4 branches)	Branch header (8 branches)	CMY-Y64-G-E	CMY-Y68-G-E																								
Branch header (4 branches)	Branch header (8 branches)																												
CMY-Y64-G-E	CMY-Y68-G-E																												
<p>■ Select Each Section of Refrigerant Piping</p> <p>(1) Section From Outdoor Unit to First Branch (A) } Each Section of Piping (2) Sections From Branch to Indoor Unit (a,b,c,d) }</p> <p>Select the size from the table to the right.</p>		<p>(1) Refrigerant Piping Diameter In Section From Outdoor Unit to First Branch (Outdoor Unit Piping Diameter)</p> <table border="1"> <thead> <tr> <th>Model</th> <th colspan="2">Piping Diameter (inch[mm])</th> </tr> </thead> <tbody> <tr> <td rowspan="2">MXZ-SM60</td> <td>Liquid Line</td> <td>3/8 [ø9.52]</td> </tr> <tr> <td>Gas Line</td> <td>3/4 [ø19.05]</td> </tr> </tbody> </table>	Model	Piping Diameter (inch[mm])		MXZ-SM60	Liquid Line	3/8 [ø9.52]	Gas Line	3/4 [ø19.05]	<p>(2) Refrigerant Piping Diameter In Section From Branch to Indoor Unit (Indoor Unit Piping Diameter)</p> <table border="1"> <thead> <tr> <th>Model number</th> <th colspan="2">Piping Diameter (inch[mm])</th> </tr> </thead> <tbody> <tr> <td rowspan="2">- 18</td> <td>Liquid Line</td> <td>1/4 [ø6.35]</td> </tr> <tr> <td>Gas Line</td> <td>1/2 [ø12.7]</td> </tr> <tr> <td rowspan="2">24 - 54</td> <td>Liquid Line</td> <td>3/8 [ø9.52]</td> </tr> <tr> <td>Gas Line</td> <td>5/8 [ø15.88]</td> </tr> <tr> <td rowspan="2">72</td> <td>Liquid Line</td> <td>3/8 [ø9.52]</td> </tr> <tr> <td>Gas Line</td> <td>3/4 [ø19.05]</td> </tr> </tbody> </table>	Model number	Piping Diameter (inch[mm])		- 18	Liquid Line	1/4 [ø6.35]	Gas Line	1/2 [ø12.7]	24 - 54	Liquid Line	3/8 [ø9.52]	Gas Line	5/8 [ø15.88]	72	Liquid Line	3/8 [ø9.52]	Gas Line	3/4 [ø19.05]
Model	Piping Diameter (inch[mm])																												
MXZ-SM60	Liquid Line	3/8 [ø9.52]																											
	Gas Line	3/4 [ø19.05]																											
Model number	Piping Diameter (inch[mm])																												
- 18	Liquid Line	1/4 [ø6.35]																											
	Gas Line	1/2 [ø12.7]																											
24 - 54	Liquid Line	3/8 [ø9.52]																											
	Gas Line	5/8 [ø15.88]																											
72	Liquid Line	3/8 [ø9.52]																											
	Gas Line	3/4 [ø19.05]																											
<p>■ Additional refrigerant charge</p>		<p>Refer to the same section in the previous page.</p>																											

Method of Combined Branching of Lines and Headers
 Connection Examples
 (Connecting to 5 Indoor Units)

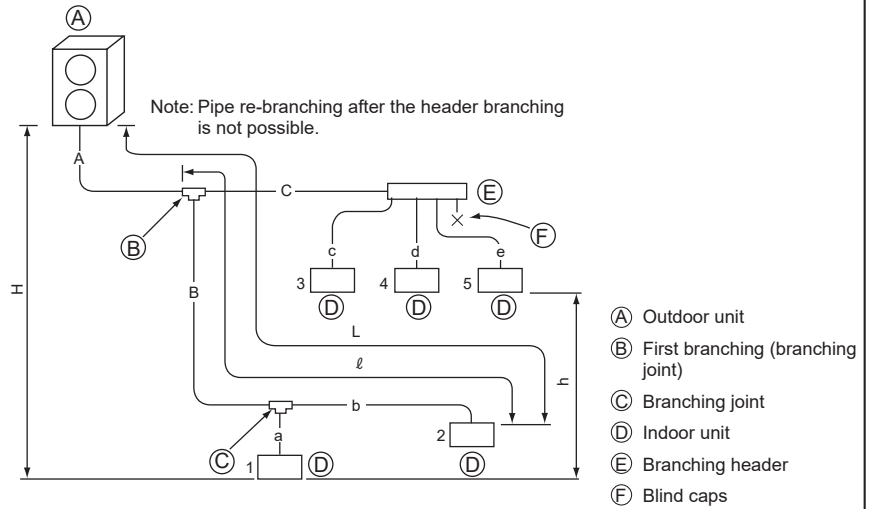

Permissible Length	Total Piping Length	A+B+C+a+b+c+d+e is 492 ft [150 meters]
	Farthest Piping Length (L)	A+B+b is 262 ft [80 meters]
	Farthest Piping Length After First Branch (l)	B+b is 100 ft [30 meters]
Permissible High/Low Difference	High/Low Difference in Indoor/Outdoor Section (H)	164 ft [50 meters] (If the outdoor unit is lower, 131 ft [40 meters] or less)
	High/Low Difference in Indoor/Indoor Section (h)	49 ft [15 meters]

■ **Selecting the Refrigerant Branch Kit**

Please select branching kit, which is sold separately, from the table below.
 (The kit comprises sets for use with liquid pipes and for use with gas pipes.)

Branch Joint	Branch Header (4 branches)	Branch Header (8 branches)
CMY-Y62-G-E	CMY-Y64-G-E	CMY-Y68-G-E

■ **Select Each Section of Refrigerant Piping**

- (1) Section From Outdoor Unit to First Branch (A)
 - (2) Sections From Branch to Indoor Unit (a,b,c,d,e)
 - (3) Section From Branch to Branch (B,C)
- } Each Section of Piping

Select the size from the table to the right.

(1) Refrigerant Piping Diameter In Section From Outdoor Unit to First Branch (Outdoor Unit Piping Diameter)

Model	Piping Diameter (inch [mm])
MXZ-SM60	Liquid Line 3/8 [ø9.52]
	Gas Line 3/4 [ø19.05]

(2) Refrigerant Piping Diameter In Section From Branch to Indoor Unit (Indoor Unit Piping Diameter)

Model number	Piping Diameter (inch [mm])
- 18	Liquid Line 1/4 [ø6.35]
	Gas Line 1/2 [ø12.7]
24 - 54	Liquid Line 3/8 [ø9.52]
	Gas Line 5/8 [ø15.88]
72	Liquid Line 3/8 [ø9.52]
	Gas Line 3/4 [ø19.05]

(3) Refrigerant Piping Diameter In Section From Branch to Branch

Liquid Line (inch [mm])	Gas Line (inch [mm])
3/8 [ø9.52]	3/4 [ø19.05]

■ **Additional refrigerant charge**

Refer to the same section in the previous page.

Branch box Method
Connection Examples
 (Connecting to 8 Indoor Units)

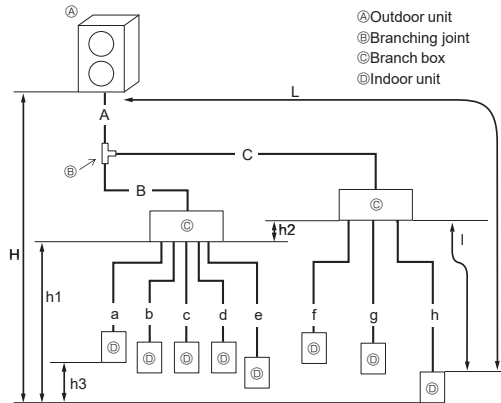

Permissible length (One-way)	Total piping length	$A + B + C + a + b + c + d + e + f + g + h$ [492 ft [150 meters]	
	Farthest piping length (L)	$A + C + h$ [262 ft [80 meters]	
	Piping length between outdoor unit and branch boxes	$A + B + C$ [180 ft [55meters]	
	Farthest piping length after branch box (I)	I [82 ft [25 meters]	
Permissible height difference (One-way)	Total piping length between branch boxes and indoor units	$a + b + c + d + e + f + g + h$ [312 ft [95 meters]	
	In indoor/outdoor section (H)*1	H [164 ft [50 meters]	
		(In the case of that outdoor unit is set higher than indoor unit)	H [131 ft [40 meters]
	In branch box/indoor unit section (h1)	(In the case of that outdoor unit is set lower than indoor unit)	$h1 + h2$ [49 ft [15 meters]
		In each branch unit (h2)	$h2$ [49 ft [15 meters]
In each indoor unit (h3)		$h3$ [39 ft [12 meters]	
Number of bends		[15	

*1 Branch box should be placed within the level between the outdoor unit and indoor units.

■ **Select Each Section of Refrigerant Piping**

- (1) Section From Outdoor Unit to Branch box (A, B, C)
 - (2) Sections From Branch box to Indoor Unit (a to h)
- } Each Section of Piping

Select the size from the table to the right.

(1) Refrigerant Piping Diameter In Section From Outdoor Unit to Branch box (Outdoor Unit Piping Diameter)

Model	Piping Diameter (inch[mm])	
MXZ-SM36/42/48	Liquid Line	3/8 [ø9.52]
	Gas Line	5/8 [ø15.88]
MXZ-SM60	Liquid Line	3/8 [ø9.52]
	Gas Line	3/4 [ø19.05]

(2) Refrigerant Piping Diameter In Section From Branch box to Indoor Unit (Indoor Unit Piping Diameter)

Indoor unit series	Model number	A Liquid pipe (inch[mm])	B Gas pipe (inch[mm])
M series or S series	- 12	1/4 [ø6.35]	3/8 [ø9.52]
	15, 18	1/4 [ø6.35]	1/2 [ø12.7]
	24 -	3/8 [ø9.52]	5/8 [ø15.88]
P series	- 18	1/4 [ø6.35]	1/2 [ø12.7]
	24 -	3/8 [ø9.52]	5/8 [ø15.88]

■ **Additional refrigerant charge**

Refer to the same section in the previous page.

10-2. PRECAUTIONS AGAINST REFRIGERANT LEAKAGE

10-2-1. Introduction

R410A refrigerant of this air conditioner is non-toxic and non-flammable but leaking of large amount from an indoor unit into the room where the unit is installed may be deleterious. To prevent possible injury, the rooms should be large enough to keep the R410A concentration specified by ISO 5149-1 as follows.

Maximum concentration
 Maximum refrigerant concentration of R410A of a room is 0.44kg/K accordance with ISO 5149-1.
 To facilitate calculation, the maximum concentration is expressed in units of kg/K [lbs/ft³] (kg [lbs] of R410A per K [ft³])

Maximum concentration of R410A: 0.027 lbs/ft³ [0.44 kg/K]

(ISO 5149-1)

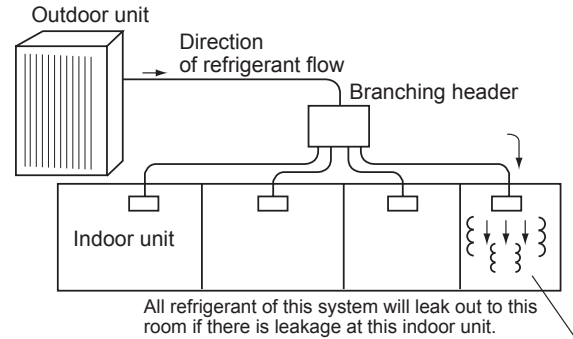

10-2-2. Confirming procedure of R410A concentration

Follow (1) to (3) to confirm the R410A concentration and take appropriate treatment, if necessary.

- (1) Calculate total refrigerant amount by each refrigerant system. Total refrigerant amount is recharged refrigerant at ex-factory plus additional charged amount at field installation.**

Note:

When the air conditioning system consists of several independent refrigerant system, figure out the total refrigerant amount by each independent refrigerant system.

- (2) Calculate room volumes (m³) and find the room with the smallest volume**

The part with represents the room with the smallest volume.

- (a) Situation in which there are no partitions**

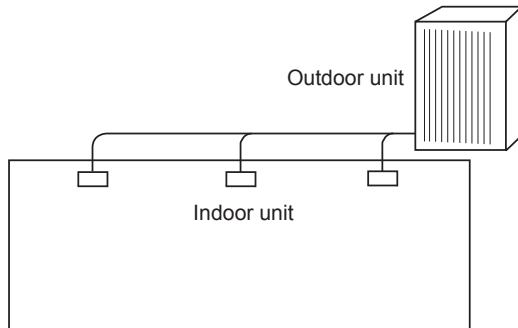

- (b) There are partitions, but there are openings that allow the effective mixing of air.**

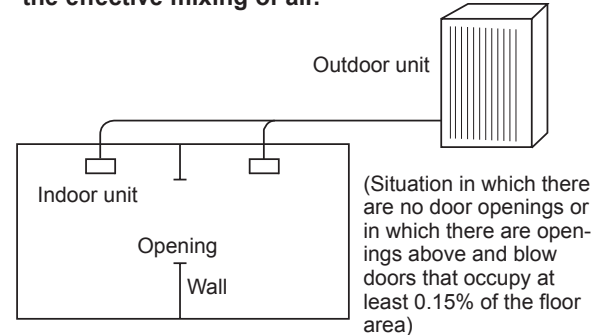

- (c) If the smallest room has mechanical ventilation apparatus that is linked to a household gas detection and alarm device, the calculations should be performed for the second smallest room.**

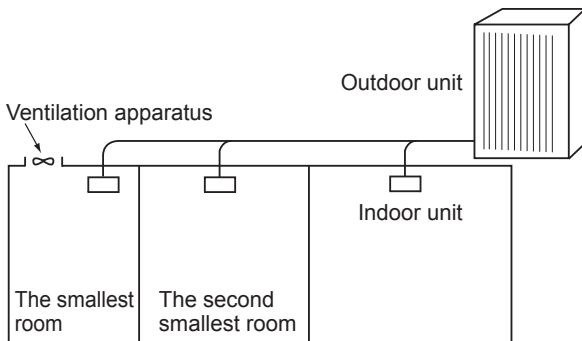

- (3) Use the results of calculations (1) and (2) to calculate the refrigerant concentration:**

$\frac{\text{Total refrigerant in the refrigerating unit (lbs [kg])}}{\text{The smallest room in which an indoor unit has been installed (ft}^3 \text{ [K])}}$ [Maximum concentration(lbs/ft³ [kg/K])

The smallest room in which an indoor unit has been installed (ft³ [K])

Maximum concentration of R410A:0.027 lbs/ft³
 [0.44kg/K]

If the calculation results do not exceed the maximum concentration, perform the same calculations for the larger second and third room, etc., until it has been determined that nowhere the maximum concentration will be exceeded.

MXZ-SM36NAM-U1 MXZ-SM48NAM-U1

→ : Indicates the visible parts in the photos/figures.

Note: Turn OFF the power supply before disassembly.

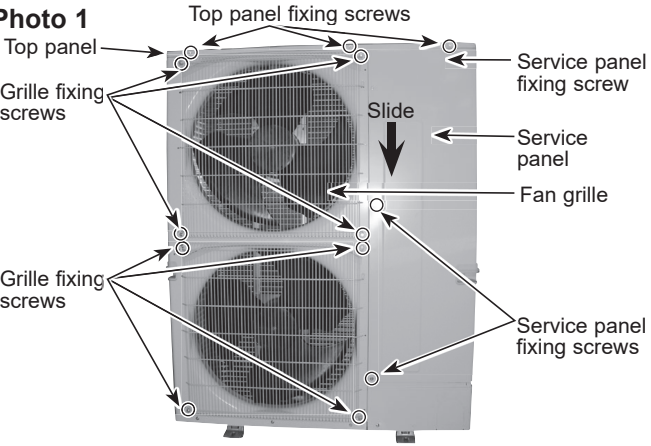
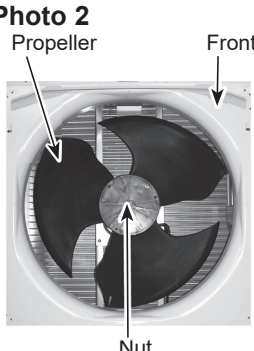
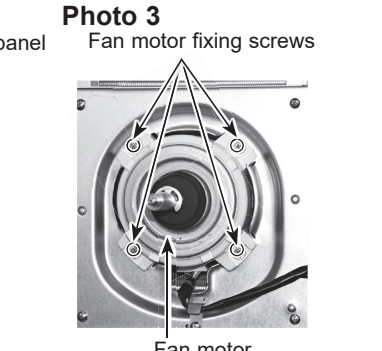
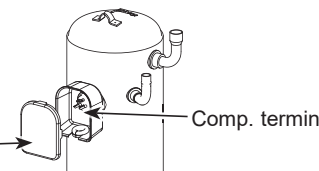
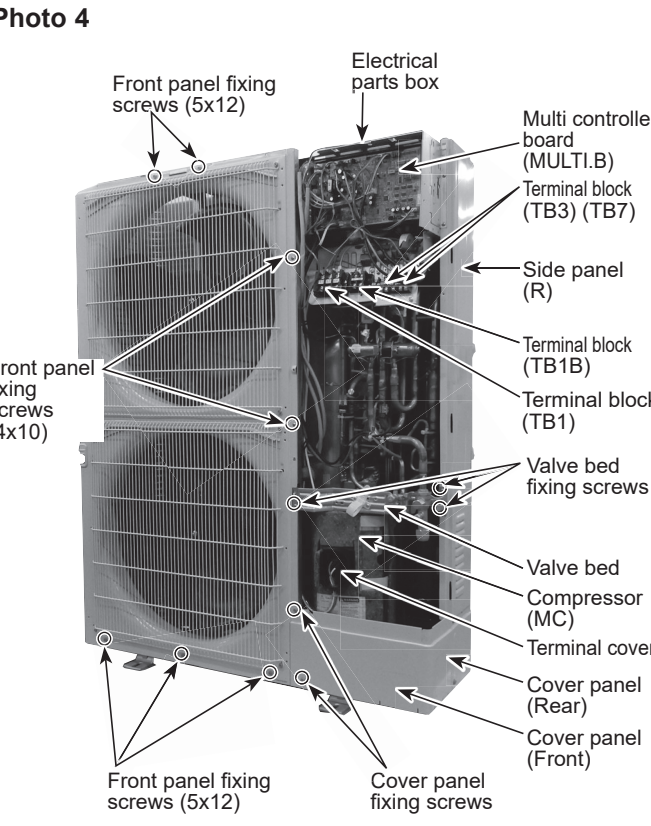
OPERATING PROCEDURE	PHOTOS/FIGURES
<p>1. Removing the service panel and top panel</p> <ol style="list-style-type: none"> Remove 3 service panel fixing screws (5 × 12) and slide the hook on the right downward to remove the service panel. Remove screws (2 for front, 3 for rear/5 × 12) of the top panel and remove it. 	<p>Photo 1</p> 
<p>2. Removing the fan motor (MF1, MF2)</p> <ol style="list-style-type: none"> Remove the service panel. (See Photo 1) Remove the top panel. (See Photo 1) Remove 4 fan grille fixing screws (5 × 12) to detach the fan grille. (See Photo 1) Remove a nut (for right handed screw of M6) to detach the propeller. (See Photo 2) Disconnect the connectors, CNF1 and CNF2 on multi controller circuit board in electrical parts box. Remove 4 fan motor fixing screws (5 × 20) to detach the fan motor. (See Photo 3) <p>Note: Torque the propeller fan to 5.7 ± 0.3 N·m [4.2 ± 0.2 ft = lbs]</p>	<div style="display: flex; justify-content: space-around;"> <div data-bbox="774 776 1029 1127"> <p>Photo 2</p>  </div> <div data-bbox="1045 776 1428 1127"> <p>Photo 3</p>  </div> </div>
<p>3. Removing the electrical parts box</p> <ol style="list-style-type: none"> Remove the service panel. (See Photo 1) Remove the top panel. (See Photo 1) Disconnect the connecting wire from terminal block. Remove all the following connectors from multi controller circuit board; <p><Diagram symbol in the connector housing></p> <ul style="list-style-type: none"> Fan motor (CNF1, CNF2) Thermistor <HIC pipe> (TH2) Thermistor <Outdoor liquid pipe> (TH3) Thermistor <Compressor> (TH4) Thermistor <Suction pipe/Ambient, Outdoor> (TH7/6) High pressure switch (63H) High pressure sensor (63HS) Low pressure sensor (63LS) 4-way valve (21S4) Bypass valve (SV1) Linear expansion valve (LEV-A, LEV-B) <p>Pull out the disconnected wire from the electrical parts box.</p> <ol style="list-style-type: none"> Remove the terminal cover and disconnect the compressor lead wire from the comp. terminal. (See Figure 1) <p>Note: The terminal cover can be easily removed by using a blade of flathead screwdriver.</p> <p>Figure 1</p> 	<p>Photo 4</p> 

From the previous page.

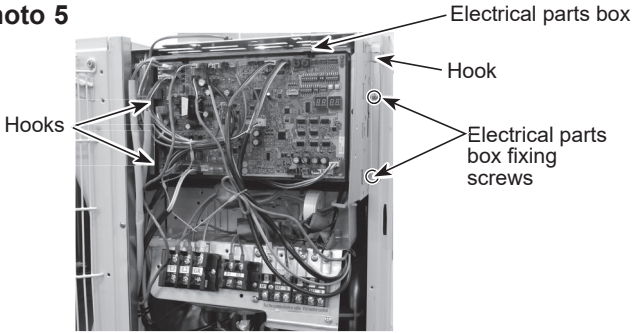
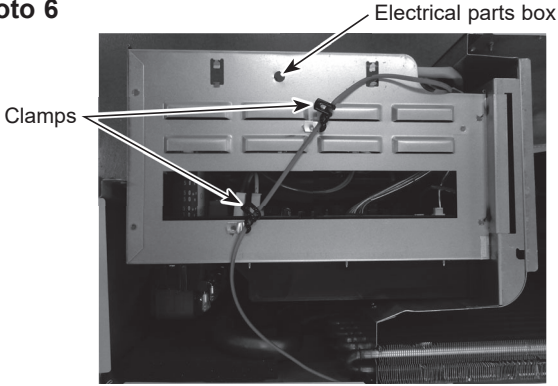
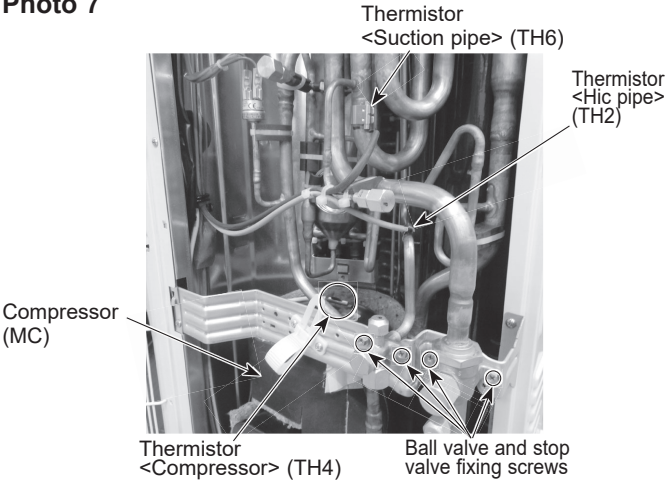
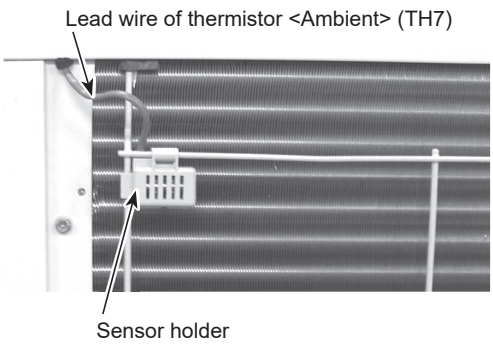
OPERATING PROCEDURE	PHOTOS/FIGURES
<p>(6) Remove 2 electrical parts box fixing screws (4 × 10) and detach the electrical parts box by pulling it upward. The electrical parts box is fixed with 2 hooks on the left and 1 hook on the right.</p>	<p>Photo 5</p> 
<p>4. Removing the thermistor <Suction pipe> (TH6)</p> <ol style="list-style-type: none"> (1) Remove the service panel. (See Photo 1) (2) Remove the top panel. (See Photo 1) (3) Disconnect the connector, TH7/6 (red), on the multi controller circuit board in the electrical parts box. (4) Loosen the wire clamps on top of the electrical parts box. (5) Pull out the thermistor <Suction pipe> (TH6) from the sensor holder. (See Photo 7) <p>Note: When replacing thermistor <Suction pipe> (TH6), replace it together with thermistor <Ambient> (TH7) since they are combined together. Refer to procedure No.5 below to remove thermistor <Ambient> (TH7).</p>	<p>Photo 6</p>  <p>Photo 7</p> 
<p>5. Removing the thermistor <Ambient> (TH7)</p> <ol style="list-style-type: none"> (1) Remove the service panel. (See Photo 1) (2) Remove the top panel. (See Photo 1) (3) Disconnect the connector TH7/6 (red) on the multi controller circuit board in the electrical parts box. (4) Loosen the wire clamps on top of the electrical parts box. (See Photo 6) (5) Pull out the thermistor <Ambient> (TH7) from the sensor holder. <p>Note: When replacing thermistor <Ambient> (TH7), replace it together with thermistor <Suction pipe> (TH6), since they are combined together. Refer to procedure No.4 above to remove thermistor <Suction pipe> (TH6).</p>	<p>Photo 8</p> 

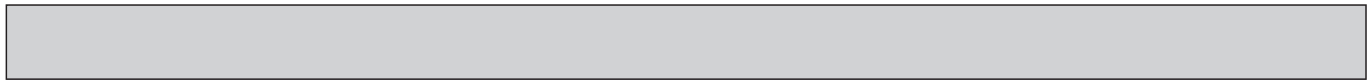

OPERATING PROCEDURE

PHOTOS/FIGURES

6. Removing the thermistor <Outdoor liquid pipe> (TH3) and thermistor <Compressor> (TH4), thermistor <HIC pipe> (TH2)

- (1) Remove the service panel. (See Photo 1)
- (2) Disconnect the connectors, TH3 (white) and TH4 (white), TH2 (black) on the multi controller circuit board in the electrical parts box.
- (3) Pull out the thermistor <Outdoor liquid pipe> (TH3) and thermistor <Compressor> (TH4) from the sensor holder. (See Photo 7 and 9)

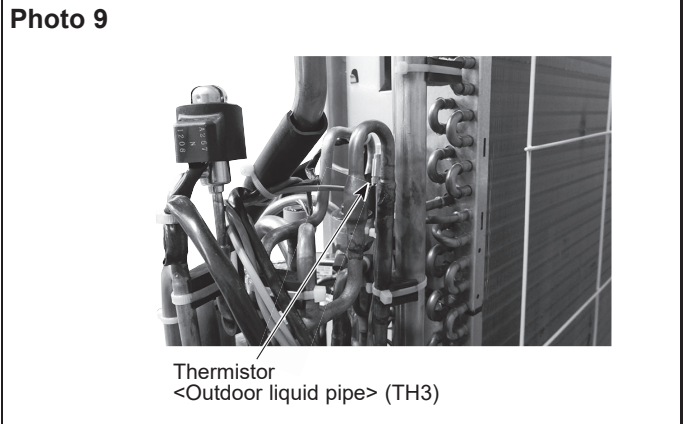

7. Removing the 4-way valve coil (21S4)

- (1) Remove the service panel. (See Photo 1)
- (2) Remove 4-way valve coil fixing screw (M5 × 7).
- (3) Remove the 4-way valve coil by sliding the coil to the right.
- (4) Disconnect the connector 21S4 (green) on the multi controller circuit board in the electrical parts box.

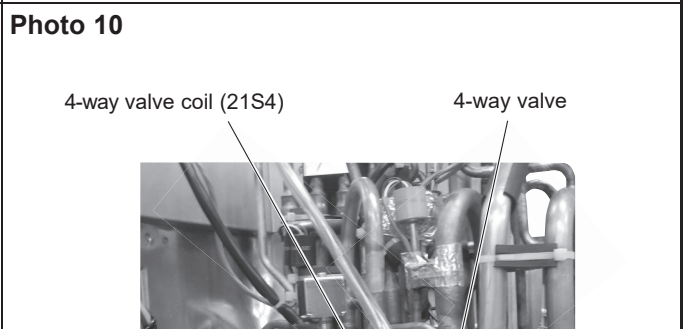

8. Removing the 4-way valve

- (1) Remove the service panel. (See Photo 1)
- (2) Remove the top panel. (See Photo 1)
- (3) Remove the electrical parts box (See Photo 5)
- (4) Remove 3 valve bed fixing screws (4 × 10) and 4 ball valve and stop valve fixing screws (5 × 16), then remove the valve bed. (See Photo 4 and 7)
- (5) Remove 2 cover panel fixing screws (5 × 12), then slide the cover panel (front) upward to remove it. (The cover panel (front) is fixed to the cover panel (rear) with a hook on the rear side. (See Photo 4)
- (6) Remove the cover panel (rear) fixing screws (2 for right side and 2 for rear/ 5 × 12), then slide the cover panel (rear) upward to remove it. (The cover panel (rear) is fixed to the side panel (R) with 2 screws.)
- (7) Remove 3 side panel (R) fixing screws (5 × 12) in the rear of the unit, then slide the side panel (R) upward to remove it. (The side panel (R) is fixed to the side plate with hooks on the rear side.)
- (8) Remove the 4-way valve coil. (See Photo 10)
- (9) Recover refrigerant.
- (10) Remove the welded part of 4-way valve.

Notes:

1. Recover refrigerant without spreading it in the air.
2. The welded part can be removed easily by removing the side panel (R).
3. When installing the 4-way valve, cover it with a wet cloth to prevent it from heating (248°F [120°C] or more), then braze the pipes so that the inside of pipes are not oxidized.

OPERATING PROCEDURE

9. Removing bypass valve coil (SV1) and bypass valve

- (1) Remove the service panel. (See Photo 1)
- (2) Remove the top panel. (See Photo 1)
- (3) Remove the cover panel (front). (Refer to procedure 8 (5))
- (4) Remove the cover panel (rear). (Refer to procedure 8 (6))
- (5) Remove the side panel (R). (Refer to procedure 8 (7))
- (6) Remove the bypass valve coil fixing screw (M4 × 6).
- (7) Remove the bypass valve coil by sliding the coil upward.
- (8) Disconnect the connector SV1 (gray) on the multi controller circuit board in the electrical parts box.
- (9) Remove the electrical parts box. (See Photo 5)
- (10) Recover refrigerant.
- (11) Remove the welded part of bypass valve.

Refer to the notes below.

10. Removing the high pressure switch (63H) and high pressure sensor (63HS)

- (1) Remove the service panel. (See Photo 1)
- (2) Remove the top panel. (See Photo 1)
- (3) Remove the cover panel (front). (Refer to procedure 8 (5))
- (4) Remove the cover panel (rear). (Refer to procedure 8 (6))
- (5) Remove the side panel (R). (Refer to procedure 8 (7))
- (6) Pull out the lead wire of high pressure switch and high pressure sensor.
- (7) Remove the electrical parts box. (See Photo 5)
- (8) Recover refrigerant.
- (9) Remove the welded part of high pressure switch and high pressure sensor.

Refer to the notes below.

11. Removing the low pressure sensor (63LS)

- (1) Remove the service panel. (See Photo 1)
- (2) Remove the top panel. (See Photo 1)
- (3) Remove the cover panel (front). (Refer to procedure 8 (5))
- (4) Remove the cover panel (rear). (Refer to procedure 8 (6))
- (5) Remove the side panel (R). (Refer to procedure 8 (7))
- (6) Disconnect the connector 63LS (blue) on the multi controller circuit board in the electrical parts box.
- (7) Remove the electrical parts box. (See Photo 5)
- (8) Recover refrigerant.
- (9) Remove the welded part of low pressure sensor.

Refer to the notes below.

12. Removing linear expansion valve (LEV-A, LEV-B)

- (1) Remove the service panel. (See Photo 1)
- (2) Remove the top panel. (See Photo 1)
- (3) Remove the cover panel (front). (Refer to procedure 8 (5))
- (4) Remove the cover panel (rear). (Refer to procedure 8 (6))
- (5) Remove the side panel (R). (Refer to procedure 8 (7))
- (6) Remove the linear expansion valve coil. (See Photo 11, 12)
- (7) Remove the electrical parts box. (See Photo 5)
- (8) Recover refrigerant.
- (9) Remove the welded part of linear expansion valve.

Refer to the notes on the right.

PHOTOS/FIGURES

Photo 11

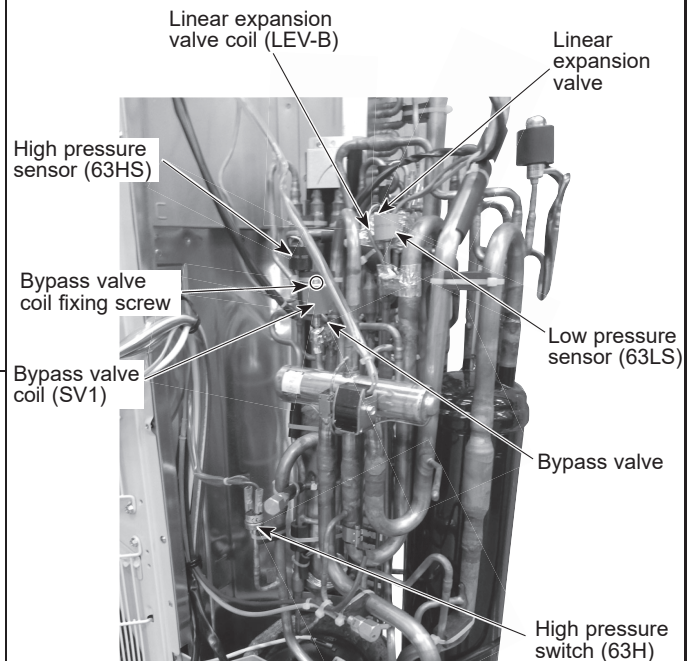
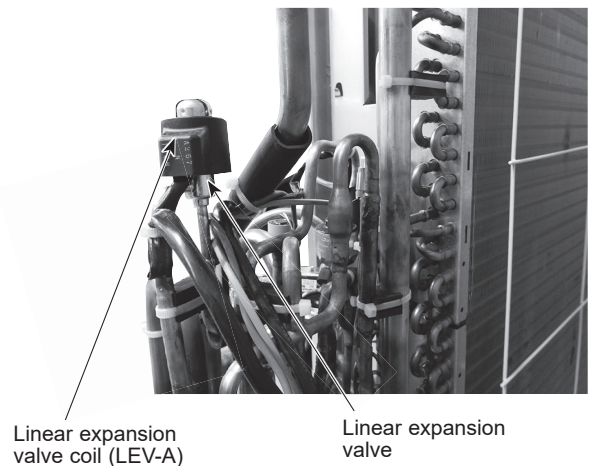

Photo 12



Notes:

1. Recover refrigerant without spreading it in the air.
2. The welded part can be removed easily by removing the side panel (R).
3. When installing the following parts, cover it with a wet cloth to prevent it from heating as the temperature below, then braze the pipes so that the inside of pipes are not oxidized;
 - Bypass valve (procedure 9), 248°F [120°C] or more
 - High pressure switch and high pressure sensor (procedure 10), 212°F [100°C] or more
 - Low pressure sensor (procedure 11), 212°F [100°C] or more
 - LEV (procedure 12), 248°F [120°C] or more

OPERATING PROCEDURE

PHOTOS/FIGURES

13. Removing the compressor (MC)

- (1) Remove the service panel. (See Photo 1)
- (2) Remove the top panel. (See Photo 1)
- (3) Remove the cover panel (front). (Refer to procedure 8(5))
- (4) Remove the cover panel (rear) (Refer to procedure 8(6))
- (5) Remove the side panel (R). (Refer to procedure 8 (7))
- (6) Remove 2 front cover panel fixing screws (5 × 12) and remove the cover panel (front). (See Photo 4)
- (7) Remove the electrical parts box. (See Photo 5)
- (8) Remove the valve bed. (Refer to procedure 8 (4))
- (9) Remove 3 separator fixing screws (4 × 10) and remove the separator. (See Figure 2)
- (10) Recover refrigerant.
- (11) Remove the 3 compressor fixing nuts for motor using spanner or adjustable wrench.
- (12) Remove the welded pipe of compressor inlet and outlet and then remove the compressor.

Note: Recover refrigerant without spreading it in the air.

Photo 13

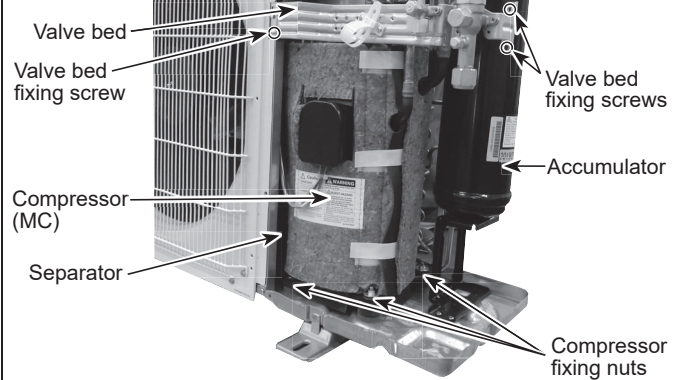
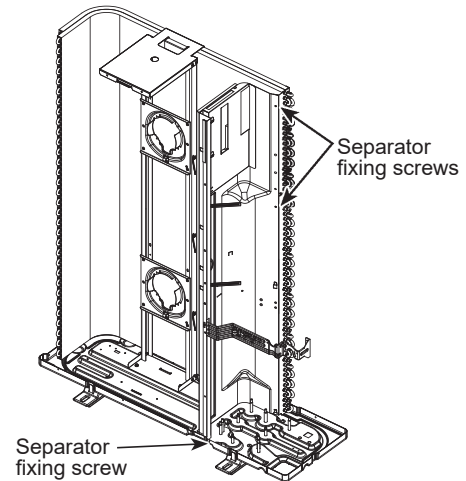

Figure 2



14. Removing the accumulator

- (1) Remove the service panel. (See Photo 1)
- (2) Remove the top panel. (See Photo 1)
- (3) Remove the cover panel (front). (Refer to procedure 8 (5))
- (4) Remove the cover panel (rear). (Refer to procedure 8 (6))
- (5) Remove the side panel (R). (Refer to procedure 8 (7))
- (6) Remove the electrical parts box. (See Photo 5)
- (7) Remove the valve bed. (Refer to procedure 8 (4))
- (8) Recover refrigerant.
- (9) Remove 4 welded pipes of accumulator inlet and outlet.
- (10) Remove 2 accumulator leg fixing screws (4 × 10). (See Photo 15)

Note: Recover refrigerant without spreading it in the air.

Photo 14

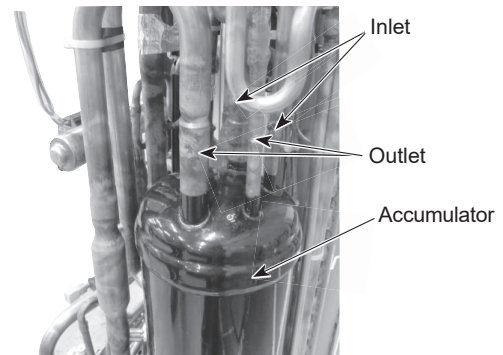
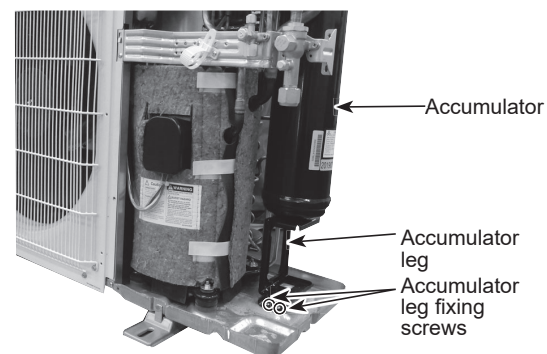
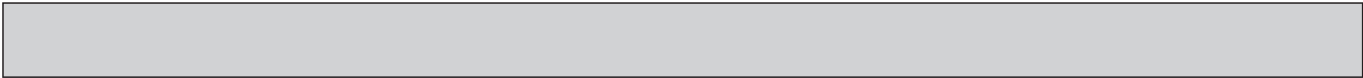
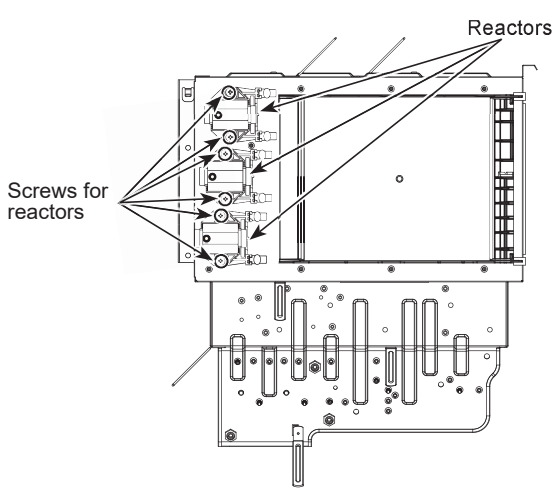

Photo 15





OPERATING PROCEDURE	PHOTOS/FIGURES
<p>15. Removing the reactor (DCL)</p> <ul style="list-style-type: none">(1) Remove the service panel. (See Photo 1)(2) Remove the top panel. (See Photo 1)(3) Remove the electrical parts box (See photo 5)(4) Remove 6 screws (4 x 10) for reactors to remove the reactors. (See Figure 3)	<p>Figure 3</p>  <p>The diagram shows a top-down view of a rectangular reactor assembly. On the left side, there are six screws arranged in two vertical columns of three. Arrows point from the label 'Screws for reactors' to these screws. On the right side, there are two rectangular components. Arrows point from the label 'Reactors' to these components. The assembly is mounted on a base with various electrical components and wiring visible.</p>

MXZ-SM60NAM-U1

→ : Indicates the visible parts in the photos/figures.

Note: Turn OFF the power supply before disassembly.

OPERATING PROCEDURE	PHOTOS/FIGURES
<p>1. Removing the service panel and top panel</p> <ol style="list-style-type: none"> Remove 3 service panel fixing screws (5 × 12) and slide the hook on the right downward to remove the service panel. Remove screws (2 for front, 3 for rear/5 × 12) on the top panel and remove it. 	<p>Photo 1</p>
<p>2. Removing the fan motor (MF1, MF2)</p> <ol style="list-style-type: none"> Remove the service panel. (See Photo 1) Remove 4 fan grille fixing screws (5 × 12) to detach the fan grille. (See Photo 1) Remove a nut (for right handed screw of M6) to detach the propeller. (See Photo 2) Disconnect the connectors, CNF1 and CNF2 on multi controller board in electrical parts box. Remove 4 fan motor fixing screws (5 × 20) to detach the fan motor. (See Photo 3) <p>Note: Torque the propeller fan to 5.7 ± 0.3 N·m [4.2 ± 0.2 ft = lbs]</p>	<p>Photo 2</p> <p>Photo 3</p>
<p>3. Removing the electrical parts box</p> <ol style="list-style-type: none"> Remove the service panel. (See Photo 1) Remove the top panel. (See Photo 1) Disconnect the connecting wire from terminal block. (See Photo 5) Remove all the following connectors from outdoor multi controller circuit board; <ul style="list-style-type: none"> <Diagram symbol in the connector housing> • Fan motor (CNF1, CNF2) • Thermistor <HIC pipe> (TH2) • Thermistor <Outdoor liquid pipe> (TH3) • Thermistor <Compressor> (TH4) • Thermistor <Suction pipe/Ambient, Outdoor> (TH7/6) • High pressure switch (63H) • High pressure sensor (63HS) • Low pressure sensor (63LS) • 4-way valve (21S4) • Bypass valve (SV1) • Linear expansion valve (CNLVA/CNLVB) Pull out the disconnected wire from the electrical parts box. Remove the terminal cover and disconnect the compressor lead wire. <p>Note: The terminal cover can be easily removed by using a blade of flathead screwdriver.</p> <p>Figure 1</p>	<p>Photo 4</p>

From the previous page.

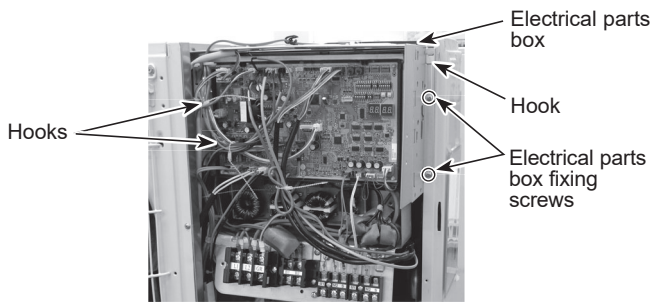
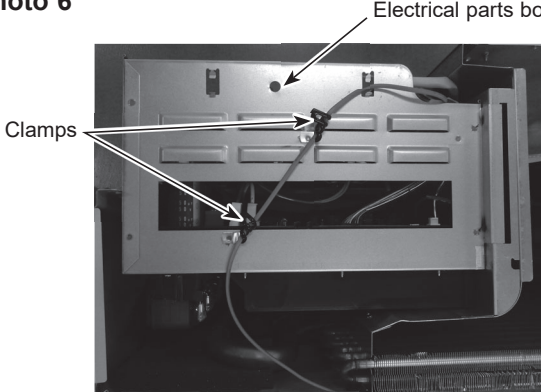
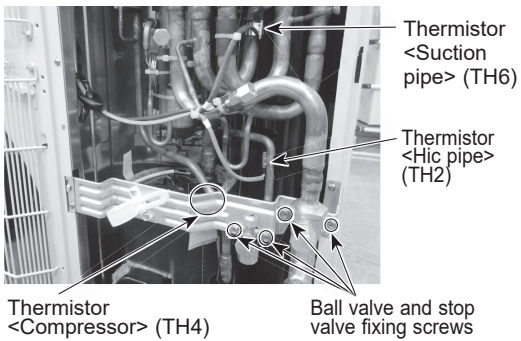
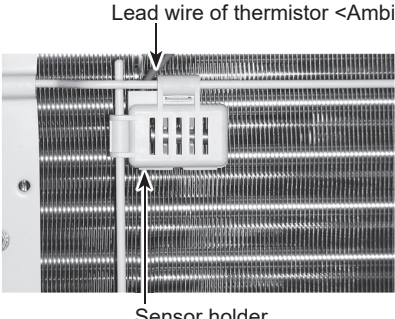
OPERATING PROCEDURE	PHOTOS/FIGURES
<p>(6) Remove 2 electrical parts box fixing screws (4 × 10) then detach the electrical parts box by pulling it upward. The electrical parts box is fixed with 2 hooks on the left and 1 hook on the right.</p>	<p>Photo 5</p> 
<p>4. Removing the thermistor <Suction pipe> (TH6)</p> <ol style="list-style-type: none"> (1) Remove the service panel. (See Photo 1) (2) Remove the top panel. (See Photo 1) (3) Disconnect the connectors, TH7/6 (red), on the multi controller circuit board in the electrical parts box. (4) Loosen the wire clamps on the back of electrical parts box. (5) Pull out the thermistor <Suction pipe> (TH6) from the sensor holder. (See Photo 7) <p>Note: When replacing thermistor <Suction pipe> (TH6), replace it together with thermistor <Ambient> (TH7) since they are combined together. Refer to procedure No.5 below to remove thermistor <Ambient> (TH7).</p>	<p>Photo 6</p> 
<p>5. Removing the thermistor <Ambient> (TH7)</p> <ol style="list-style-type: none"> (1) Remove the service panel. (See Photo 1) (2) Remove the top panel. (See Photo 1) (3) Disconnect the connector TH7/6 (red) on the multi controller circuit board in the electrical parts box. (4) Loosen the wire clamps on top of the electrical parts box. (See Photo 6.) (5) Pull out the thermistor <Ambient> (TH7) from the sensor holder. <p>Note: When replacing thermistor <Ambient> (TH7), replace it together with thermistor <Suction pipe> (TH6), since they are combined together. Refer to procedure No.4 above to remove thermistor <Suction pipe> (TH6).</p>	<p>Photo 7</p>  <p>Photo 8</p> 

OPERATING PROCEDURE

6. Removing the thermistor <Outdoor liquid pipe> (TH3) and thermistor <Compressor> (TH4), thermistor <HIC pipe> (TH2)

- (1) Remove the service panel. (See Photo 1)
- (2) Disconnect the connectors, TH3 (white) and TH4 (white), TH2 (black) on the multi controller circuit board in the electrical parts box.
- (3) Pull out the thermistor <Outdoor liquid pipe> (TH3) and thermistor <Compressor> (TH4) from the sensor holder. (See Photo 9-1 and 9-2)

PHOTOS/FIGURES

Photo 9-1

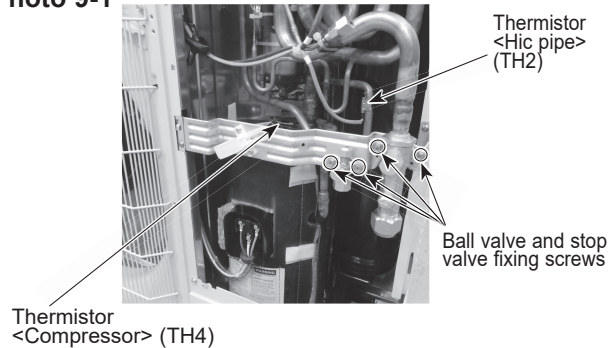
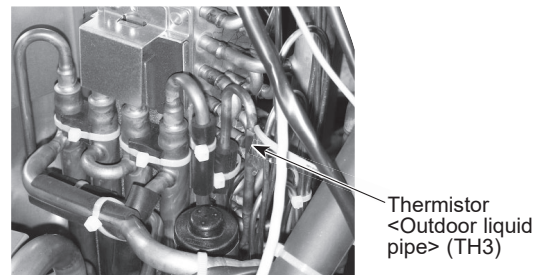

Photo 9-2



7. Removing the 4-way valve coil (21S4)

- (1) Remove the service panel. (See Photo 1)
- (2) Remove 4-way valve coil fixing screw (M5 × 7).
- (3) Remove the 4-way valve coil by sliding the coil to the right.
- (4) Disconnect the connector 21S4 (green) on the multi controller circuit board in the electrical parts box.

Photo 10



8. Removing the 4-way valve

- (1) Remove the service panel. (See Photo 1)
- (2) Remove the top panel. (See Photo 1)
- (3) Remove the electrical parts box (See Photo 5)
- (4) Remove 3 valve bed fixing screws (4 × 10) and 4 ball valve and stop valve fixing screws (5 × 16), then remove the valve bed. (See Photo 4 and 7)
- (5) Remove 2 cover panel fixing screws (5 × 12), then slide the cover panel (front) upward to remove it. (The cover panel (front) is fixed to the cover panel (rear) with a hook on the rear side. (See Photo 4)
- (6) Remove the cover panel (rear) fixing screws (2 for right side and 2 for rear/ 5 × 12), then slide the cover panel (rear) upward to remove it. (The cover panel (rear) is fixed to the side panel (R) with 2 screws.)
- (7) Remove 3 side panel (R) fixing screws (5 × 12) in the rear of the unit, then slide the side panel (R) upward to remove it. (The side panel (R) is fixed to the side plate with hooks on the rear side.)
- (8) Remove the 4-way valve coil. (See Photo 10)
- (9) Recover refrigerant.
- (10) Remove the welded part of 4-way valve.

Notes:

1. Recover refrigerant without spreading it in the air.
2. The welded part can be removed easily by removing the side panel (R).
3. When installing the 4-way valve, cover it with a wet cloth to prevent it from heating (248°F [120°C] or more), then braze the pipes so that the inside of pipes are not oxidized.

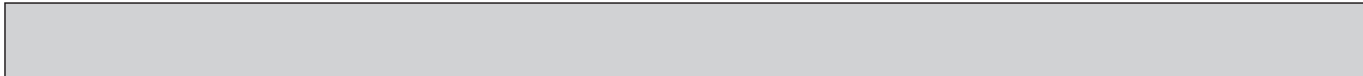

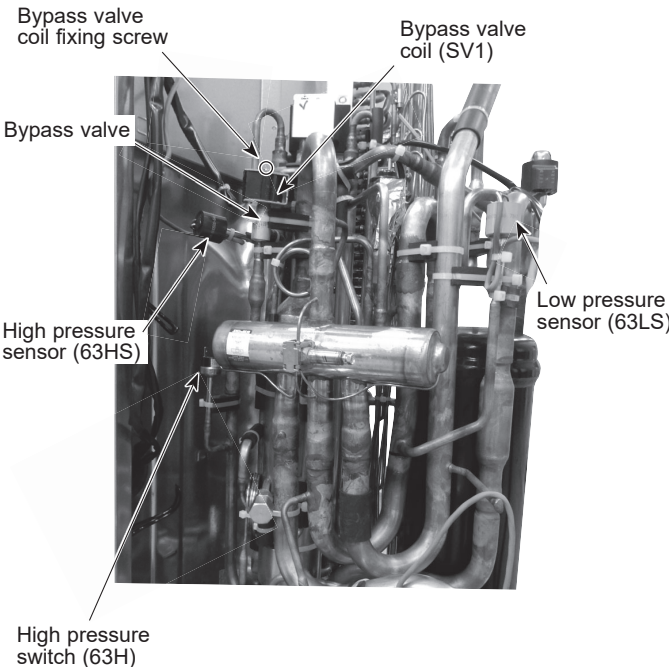
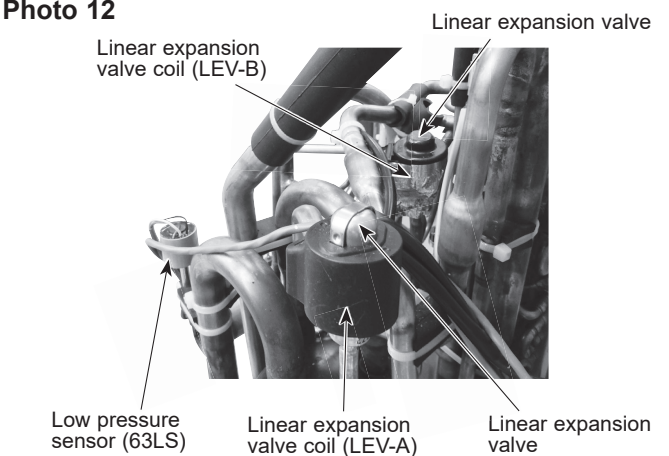
OPERATING PROCEDURE	PHOTOS/FIGURES
<p>9. Removing bypass valve coil (SV1) and bypass valve</p> <ol style="list-style-type: none"> (1) Remove the service panel. (See Photo 1) (2) Remove the top panel. (See Photo 1) (3) Remove the cover panel (front). (Refer to procedure 8(5)) (4) Remove the cover panel (rear) (Refer to procedure 8(6)) (5) Remove the side panel (R). (Refer to procedure 8 (7)) (6) Remove the bypass valve coil fixing screw (M4 × 6). (7) Remove the bypass valve coil by sliding the coil upward. (8) Disconnect the connector SV1 (gray) on the multi controller circuit board in the electrical parts box. (9) Remove the electrical parts box. (See Photo 5) (10) Recover refrigerant. (11) Remove the welded part of bypass valve. <p>Refer to the notes below.</p>	<p>Photo 11</p> 
<p>10. Removing the high pressure switch (63H) and high pressure sensor (63HS)</p> <ol style="list-style-type: none"> (1) Remove the service panel. (See Photo 1) (2) Remove the top panel. (See Photo 1) (3) Remove the cover panel (front). (Refer to procedure 8(5)) (4) Remove the cover panel (rear) (Refer to procedure 8(6)) (5) Remove the side panel (R). (Refer to procedure 8 (7)) (6) Pull out the lead wire of high pressure switch and high pressure sensor. (7) Remove the electrical parts box. (See Photo 5) (8) Recover refrigerant. (9) Remove the welded part of high pressure switch and high pressure sensor. <p>Refer to the notes below.</p>	<p>Photo 12</p> 
<p>11. Removing the low pressure sensor (63LS)</p> <ol style="list-style-type: none"> (1) Remove the service panel. (See Photo 1) (2) Remove the top panel. (See Photo 1) (3) Remove the cover panel (front). (Refer to procedure 8(5)) (4) Remove the cover panel (rear) (Refer to procedure 8(6)) (5) Remove the side panel (R). (Refer to procedure 8 (7)) (6) Disconnect the connector 63LS (blue) on the multi controller circuit board in the electrical parts box. (7) Remove the electrical parts box. (See Photo 5) (8) Recover refrigerant. (9) Remove the welded part of low pressure sensor. <p>Refer to the notes below.</p>	<p>Notes:</p> <ol style="list-style-type: none"> 1. Recover refrigerant without spreading it in the air. 2. The welded part can be removed easily by removing the right side panel. 3. When installing the following parts, cover it with a wet cloth to prevent it from heating as the temperature below, then braze the pipes so that the inside of pipes are not oxidized; <ul style="list-style-type: none"> • Bypass valve (procedure 9), 248°F [120°C] or more • High pressure switch and high pressure sensor (procedure 10), 212°F [100°C] or more • Low pressure sensor (procedure 11), 100°C or more • LEV (procedure 12), 248°F [120°C] or more
<p>12. Removing linear expansion valve (LEV-A, LEV-B)</p> <ol style="list-style-type: none"> (1) Remove the service panel. (See Photo 1) (2) Remove the top panel. (See Photo 1) (3) Remove the cover panel (front). (Refer to procedure 8(5)) (4) Remove the cover panel (rear) (Refer to procedure 8(6)) (5) Remove the side panel (R). (Refer to procedure 8 (7)) (6) Remove the linear expansion valve coil. (See Photo 12) (7) Remove the electrical parts box. (See Photo 5) (8) Recover refrigerant. (9) Remove the welded part of linear expansion valve. 	

OPERATING PROCEDURE

13. Removing the compressor (MC)

- (1) Remove the service panel. (See Photo 1)
- (2) Remove the top panel. (See Photo 1)
- (3) Remove the cover panel (front). (Refer to procedure 8(5))
- (4) Remove the cover panel (rear) (Refer to procedure 8(6))
- (5) Remove the side panel (R). (Refer to procedure 8 (7))
- (6) Remove 2 front cover panel fixing screws (5 × 12) and remove the front cover panel. (See Photo 4)
- (7) Remove the electrical parts box. (See Photo 5)
- (8) Remove the valve bed. (Refer to procedure 8 (4))
- (9) Remove 3 separator fixing screws (4 × 10) and remove the separator. (See Figure 2)
- (10) Recover refrigerant.
- (11) Remove the 3 compressor fixing nuts for motor using spanner or adjustable wrench.
- (12) Remove the welded pipe of compressor inlet and outlet and then remove the compressor.

Note: Recover refrigerant without spreading it in the air.

PHOTOS/FIGURES

Photo 13

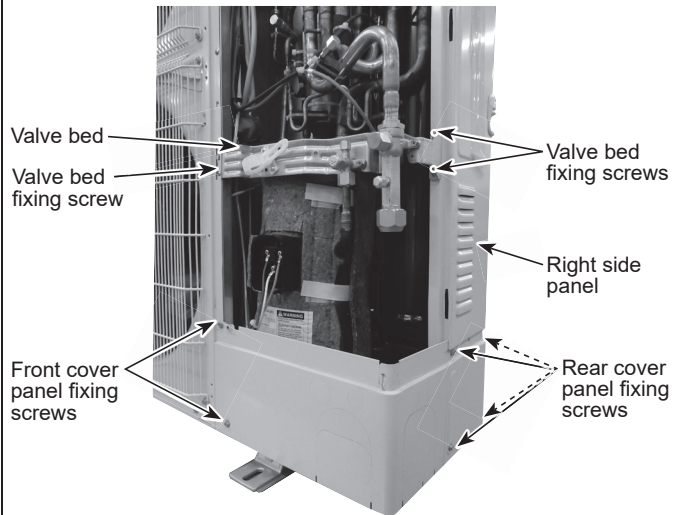

Figure 2

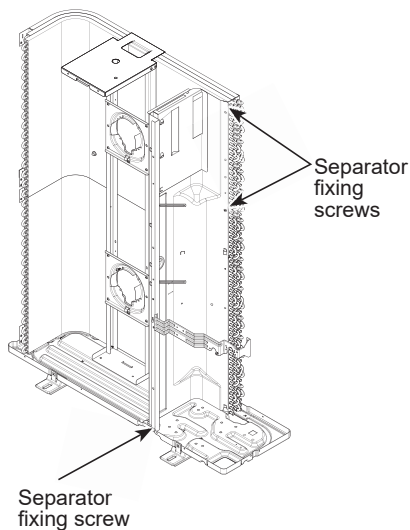
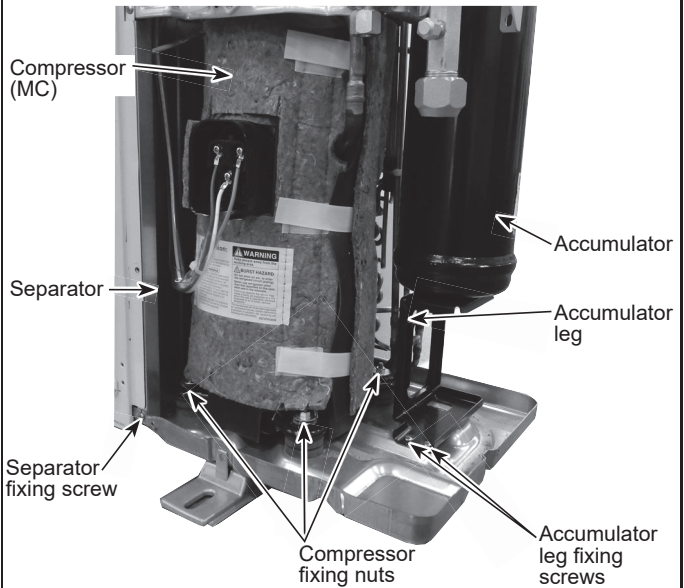

Photo 14



OPERATING PROCEDURE

14. Removing the accumulator

- (1) Remove the service panel. (See Photo 1)
- (2) Remove the top panel. (See Photo 1)
- (3) Remove the electrical parts box. (See Photo 5)
- (4) Remove the valve bed. (See procedure 8 (4))
- (5) Remove the cover panel (front). (Refer to procedure 8(5))
- (6) Remove the cover panel (rear) (Refer to procedure 8(6))
- (7) Remove the side panel (R). (Refer to procedure 8 (7))
- (8) Recover refrigerant.
- (9) Remove 2 welded pipes of accumulator inlet and outlet.
- (10) Remove 2 accumulator leg fixing screws (4 × 10). (See Photo 16)

Note: Recover refrigerant without spreading it in the air.

PHOTOS/FIGURES

Photo 15

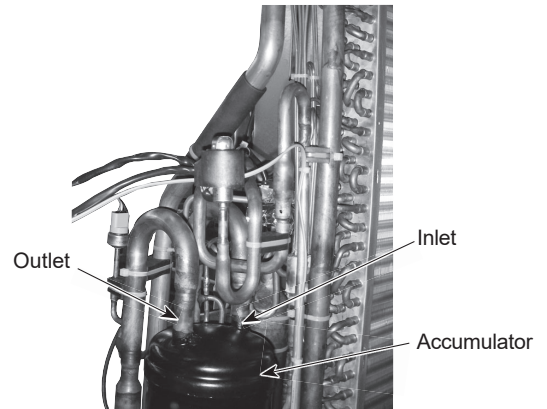
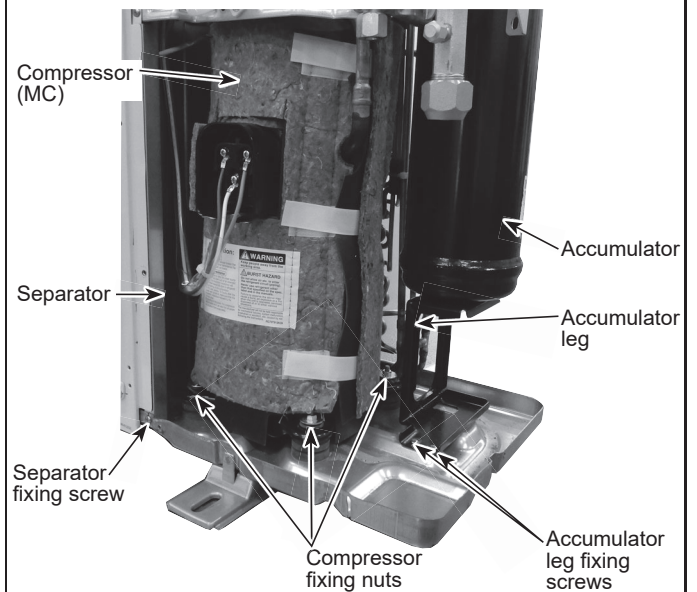

Photo 16



15. Removing the reactor (DCL)

- (1) Remove the service panel. (See Photo 1)
- (2) Remove the top panel. (See Photo 1)
- (3) Remove the electrical parts box (See photo 5)
- (4) Remove 6 screws (4 x 10) for reactors to remove the reactors. (See Figure 3)

Figure 3

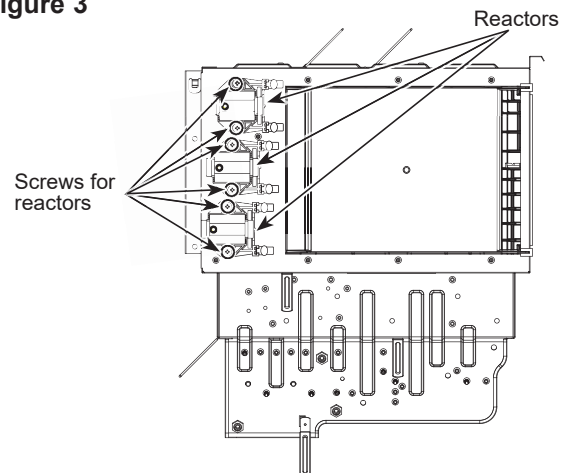

→ : Indicates the visible parts in the photos/figures.

OPERATING PROCEDURE	PHOTOS/FIGURES
<p>1. Removing the service panel and top panel</p> <ol style="list-style-type: none"> Remove 3 service panel fixing screws (5 × 12), then slide the hook on the right downward to remove the service panel. Remove screws (2 for front, 3 for rear/5 × 12) of the top panel and remove it. 	<p>Photo 1</p>
<p>2. Removing the fan motor (MF1, MF2)</p> <ol style="list-style-type: none"> Remove the service panel. (See Photo 1) Remove the top panel. (See Photo 1) Remove 4 fan grille fixing screws (5 × 12) to detach the fan grille. (See Photo 1) Remove a nut (for right handed screw of M6) to detach the propeller. (See Photo 2) Disconnect the connectors, CNF1 and CNF2 on the multi controller circuit board in the electrical parts box. Remove 4 fan motor fixing screws (5 × 20) to detach the fan motor. (See Photo 3) <p>Note: Torque the propeller fan to 5.7 ± 0.3 N·m. [4.2 ± 0.2 ft · lbs]</p>	<p>Photo 2</p> <p>Photo 3</p>
<p>3. Removing the electrical parts box</p> <ol style="list-style-type: none"> Remove the service panel. (See Photo 1) Remove the top panel. (See Photo 1) Disconnect the connecting wire from terminal block. Remove all of the following connectors from multi controller circuit board; <p><Diagram symbol in the connector housing></p> <ul style="list-style-type: none"> Fan motor (CNF1, CNF2) Thermistor <HIC pipe> (TH2) Thermistor <Outdoor liquid pipe> (TH3) Thermistor <Compressor> (TH4) Thermistor <Suction pipe/Ambient, Outdoor> (TH7/6) High pressure switch (63H) High pressure sensor (63HS) Low pressure sensor (63LS) 4-way valve (21S4) Bypass valve (SV1, SV2) Linear expansion valve (LEV-A, LEV-B) Base heater (SS) <p>Pull out the disconnected wire from the electrical parts box.</p> <ol style="list-style-type: none"> Remove the terminal cover and disconnect the compressor lead wire from the comp. terminal. (See Figure 1) <p>Note: The terminal cover can be easily removed by using a blade of flathead screwdriver.</p> <p>Figure 1</p>	<p>Photo 4</p>

Continue to the next page.

From the previous page.

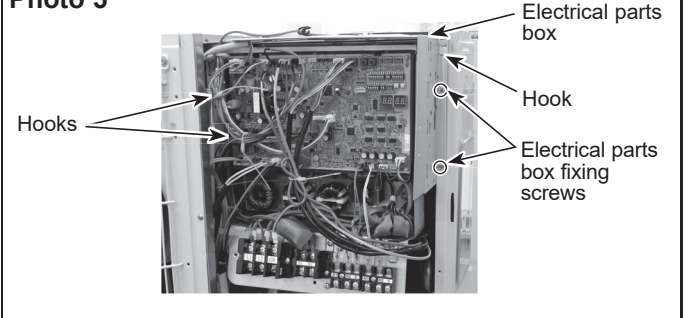
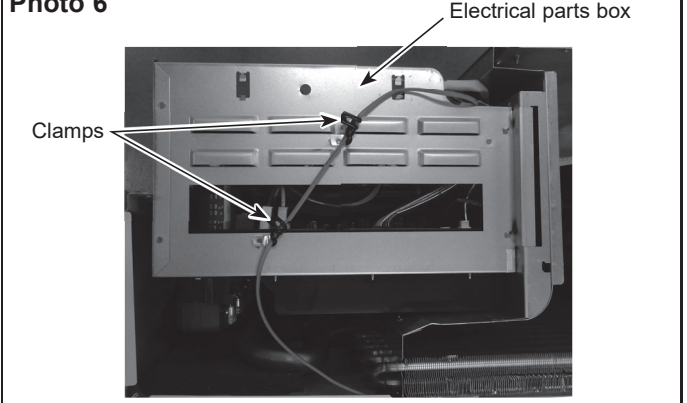
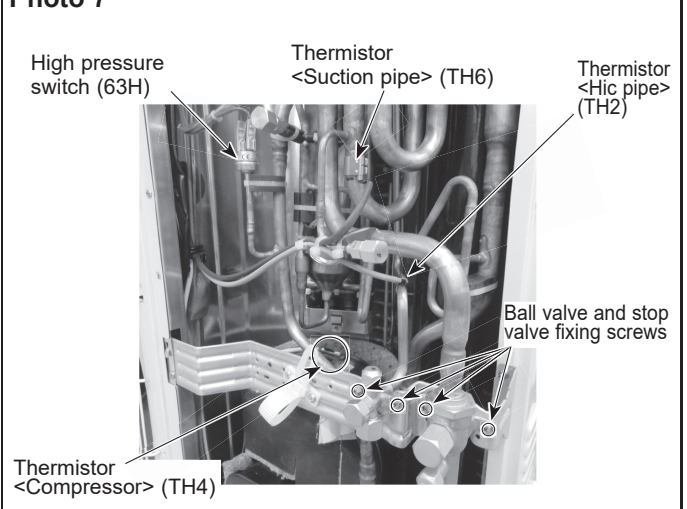
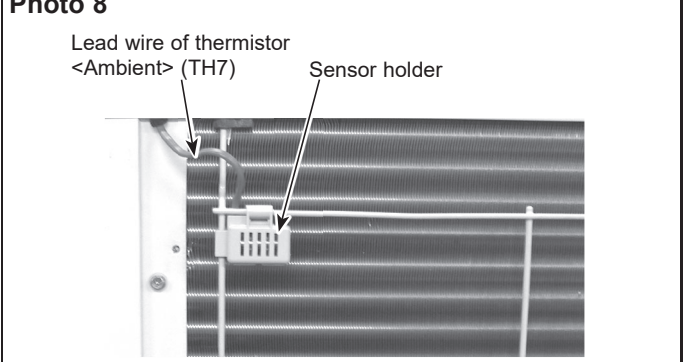
OPERATING PROCEDURE	PHOTOS/FIGURES
<p>(6) Remove 2 electrical parts box fixing screws (4 × 10), then detach the electrical parts box by pulling it upward. The electrical parts box is fixed with 2 hooks on the left and 1 hook on the right.</p>	<p>Photo 5</p> 
<p>4. Removing the thermistor <Suction pipe> (TH6)</p> <ol style="list-style-type: none"> (1) Remove the service panel. (See Photo 1) (2) Remove the top panel. (See Photo 1) (3) Disconnect the connector, TH7/6 (red), on the multi controller circuit board in the electrical parts box. (4) Loosen the wire clamps on the top of the electrical parts box. (See Photo 6) (5) Pull out the thermistor <Suction pipe> (TH6) from the sensor holder. (See Photo 7) <p>Note: When replacing thermistor <Suction pipe> (TH6), replace it together with thermistor <Ambient> (TH7) since they are combined together. Refer to procedure No.5 below to remove thermistor <Ambient> (TH7).</p>	<p>Photo 6</p>  <p>Photo 7</p> 
<p>5. Removing the thermistor <Ambient> (TH7)</p> <ol style="list-style-type: none"> (1) Remove the service panel. (See Photo 1) (2) Remove the top panel. (See Photo 1) (3) Disconnect the connector TH7/6 (red) on the multi controller circuit board in the electrical parts box. (4) Loosen the wire clamps on top of the electrical parts box. (See Photo 6) (5) Pull out the thermistor <Ambient> (TH7) from the sensor holder. <p>Note: When replacing thermistor <Ambient> (TH7), replace it together with thermistor <Suction pipe> (TH6), since they are combined together. Refer to procedure No.4 above to remove thermistor <Suction pipe> (TH6).</p>	<p>Photo 8</p> 

OPERATING PROCEDURE

PHOTOS/FIGURES

6. Removing the thermistor <Outdoor liquid pipe> (TH3) and thermistor <Compressor> (TH4), thermistor <HIC pipe> (TH2)

- (1) Remove the service panel. (See Photo 1)
- (2) Disconnect the connectors, TH3 (white) and TH4 (white), TH2 (black) on the multi controller circuit board in the electrical parts box.
- (3) Pull out the thermistor <Outdoor liquid pipe> (TH3) and thermistor <Compressor> (TH4) from the sensor holder. (See Photo 7 and 9)

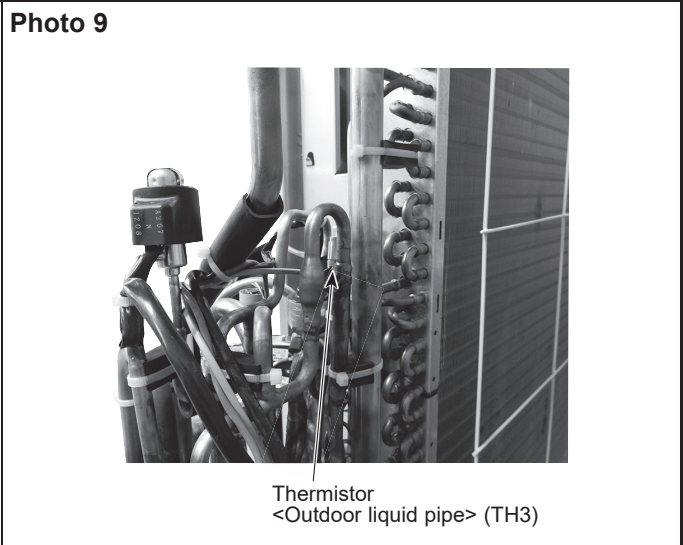

7. Removing the 4-way valve coil (21S4)

- (1) Remove the service panel. (See Photo 1)
- (2) Remove 4-way valve coil fixing screw (M5 x 7).
- (3) Remove the 4-way valve coil by sliding the coil to the right.
- (4) Disconnect the connector 21S4 (green) on the multi controller circuit board in the electrical parts box.

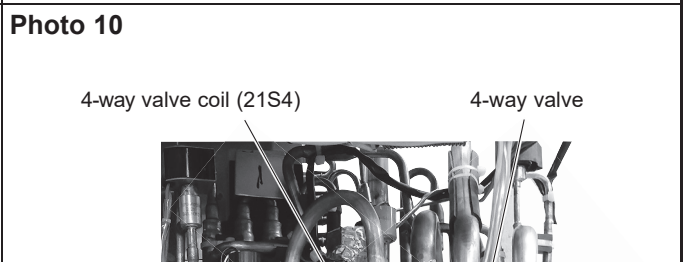

8. Removing the 4-way valve

- (1) Remove the service panel. (See Photo 1)
- (2) Remove the top panel. (See Photo 1)
- (3) Remove the electrical parts box (See Photo 5)
- (4) Remove 3 valve bed fixing screws (4 x 10) and 4 ball valve and stop valve fixing screws (5 x 16), then remove the valve bed. (See Photo 4 and 7)
- (5) Remove 2 cover panel fixing screws (5 x 12), then slide the cover panel (front) upward to remove it. (The cover panel (front) is fixed to the cover panel (rear) with a hook on the rear side. (See Photo 4)
- (6) Remove the cover panel (rear) fixing screws (2 for right side and 2 for rear/ 5 x 12), then slide the cover panel (rear) upward to remove it. (The cover panel (rear) is fixed to the side panel (R) with 2 screws.)
- (7) Remove 3 side panel (R) fixing screws (5 x 12) in the rear of the unit, then slide the side panel (R) upward to remove it. (The side panel (R) is fixed to the side plate with hooks on the rear side.)
- (8) Remove the 4-way valve coil. (See Photo 10)
- (9) Recover refrigerant.
- (10) Remove the welded part of 4-way valve.

Notes:

1. Recover refrigerant without spreading it in the air.
2. The welded part can be removed easily by removing the side panel (R).
3. When installing the 4-way valve, cover it with a wet cloth to prevent it from heating (248°F [120°C] or more), then braze the pipes so that the inside of pipes are not oxidized.

OPERATING PROCEDURE

9. Removing bypass valve coil (SV1, SV2) and bypass valve

- (1) Remove the service panel. (See Photo 1)
 - (2) Remove the top panel. (See Photo 1)
 - (3) Remove the cover panel (front). (Refer to procedure 8(5))
 - (4) Remove the cover panel (rear) (Refer to procedure 8(6))
 - (5) Remove the side panel (R). (Refer to procedure 8 (7))
 - (6) Remove the bypass valve coil fixing screw (M4 × 6).
 - (7) Remove the bypass valve coil by sliding the coil upward.
 - (8) Disconnect the connector SV1 (gray) or SV2 (blue) on the multi controller circuit board in the electrical parts box.
 - (9) Remove the electrical parts box. (See Photo 5)
 - (10) Recover refrigerant.
 - (11) Remove the welded part of bypass valve.
- Refer to the notes below.**

10. Removing the high pressure switch (63H) and high pressure sensor (63HS)

- (1) Remove the service panel. (See Photo 1)
 - (2) Remove the top panel. (See Photo 1)
 - (3) Remove the cover panel (front). (Refer to procedure 8(5))
 - (4) Remove the cover panel (rear) (Refer to procedure 8(6))
 - (5) Remove the side panel (R). (Refer to procedure 8 (7))
 - (6) Pull out the lead wire of high pressure switch and high pressure sensor.
 - (7) Remove the electrical parts box. (See Photo 5)
 - (8) Recover refrigerant.
 - (9) Remove the welded part of high pressure switch and high pressure sensor.
- Refer to the notes below.**

11. Removing the low pressure sensor (63LS)

- (1) Remove the service panel. (See Photo 1)
 - (2) Remove the top panel. (See Photo 1)
 - (3) Remove the cover panel (front). (Refer to procedure 8(5))
 - (4) Remove the cover panel (rear) (Refer to procedure 8(6))
 - (5) Remove the side panel (R). (Refer to procedure 8 (7))
 - (6) Disconnect the connector 63LS (blue) on the multi controller circuit board in the electrical parts box.
 - (7) Remove the electrical parts box. (See Photo 5)
 - (8) Recover refrigerant.
 - (9) Remove the welded part of low pressure sensor.
- Refer to the notes below.**

12. Removing linear expansion valve (LEV-A, LEV-B)

- (1) Remove the service panel. (See Photo 1)
 - (2) Remove the top panel. (See Photo 1)
 - (3) Remove the cover panel (front). (Refer to procedure 8(5))
 - (4) Remove the cover panel (rear) (Refer to procedure 8(6))
 - (5) Remove the side panel (R). (Refer to procedure 8 (7))
 - (6) Remove the linear expansion valve coil. (See Photo 11,12)
 - (7) Remove the electrical parts box. (See Photo 5)
 - (8) Recover refrigerant.
 - (9) Remove the welded part of linear expansion valve.
- Refer to the notes on the right.**

PHOTOS/FIGURES

Photo 11

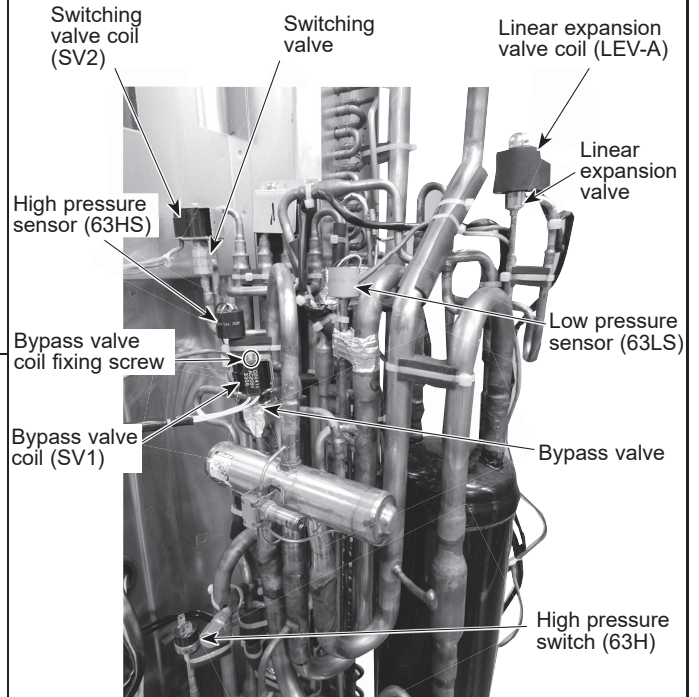
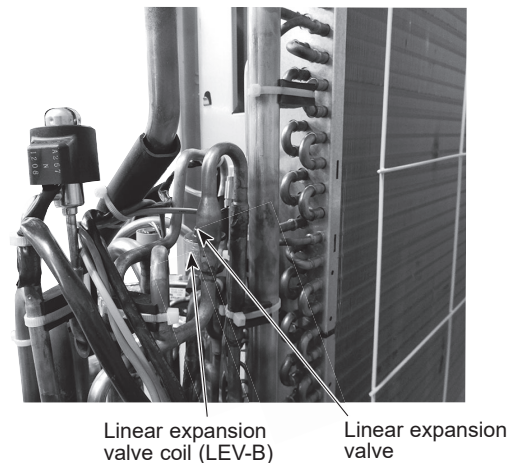

Photo 12



Notes:

1. Recover refrigerant without spreading it in the air.
2. The welded part can be removed easily by removing the side panel (R).
3. When installing the following parts, cover it with a wet cloth to prevent it from heating as the temperature below, then braze the pipes so that the inside of pipes are not oxidized;
 - Bypass valve (procedure 9), 248°F [120°C] or more
 - High pressure switch and high pressure sensor (procedure 10), 212°F [100°C] or more
 - Low pressure sensor (procedure 11), 212°F [100°C] or more
 - LEV (procedure 12), 248°F [120°C] or more

OPERATING PROCEDURE

13. Removing the compressor (MC)

- (1) Remove the service panel. (See Photo 1)
- (2) Remove the top panel. (See Photo 1)
- (3) Remove the cover panel (front). (Refer to procedure 8(5))
- (4) Remove the cover panel (rear) (Refer to procedure 8(6))
- (5) Remove the side panel (R). (Refer to procedure 8 (7))
- (6) Remove 2 front cover panel fixing screws (5 × 12) and remove the cover panel (front). (See Photo 4)
- (7) Remove the electrical parts box. (See Photo 5)
- (8) Remove the valve bed. (Refer to procedure 8 (4))
- (9) Remove 3 separator fixing screws (4 × 10) and remove the separator. (See Figure 2)
- (10) Recover refrigerant.
- (11) Remove the 3 compressor fixing nuts for motor using spanner or adjustable wrench.
- (12) Remove the welded pipe of compressor inlet and outlet and then remove the compressor.

Note: Recover refrigerant without spreading it in the air.

PHOTOS/FIGURES

Photo 13

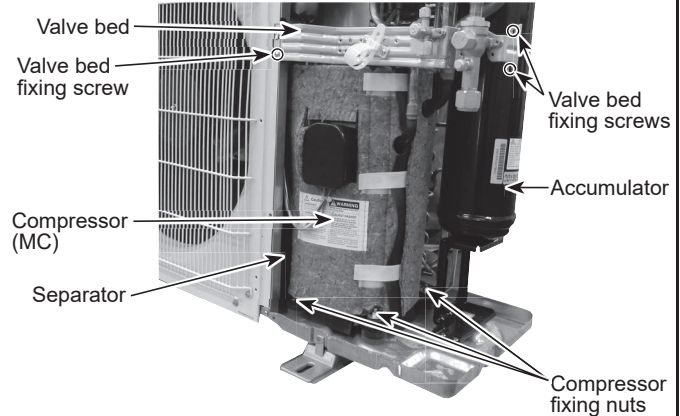
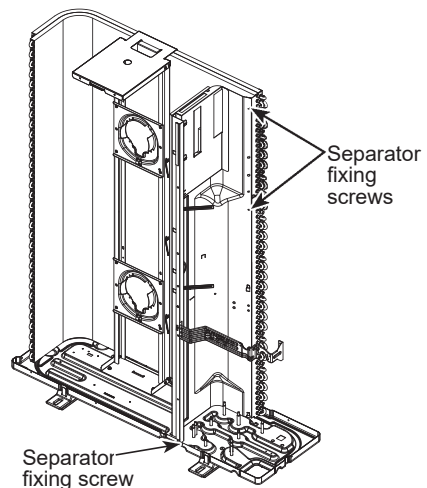

Figure 2



14. Removing the accumulator

- (1) Remove the service panel. (See Photo 1)
- (2) Remove the top panel. (See Photo 1)
- (3) Remove the cover panel (front). (Refer to procedure 13 (3))
- (4) Remove the cover panel (rear). (Refer to procedure 13 (5))
- (5) Remove the side panel (R). (Refer to procedure 8 (7))
- (6) Remove the electrical parts box. (See Photo 5)
- (7) Remove the valve bed. (See procedure 8 (4))
- (8) Recover refrigerant.
- (9) Remove 4 welded pipes of accumulator inlet and outlet.
- (10) Remove 2 accumulator leg fixing screws (4 × 10). (See Photo 15)

Note: Recover refrigerant without spreading it in the air.

Photo 14

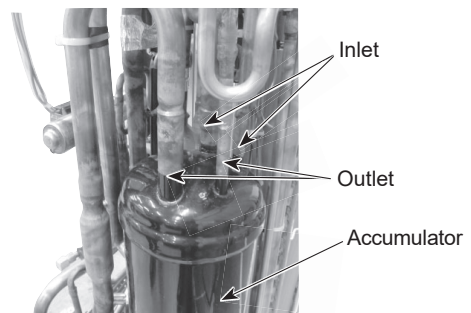
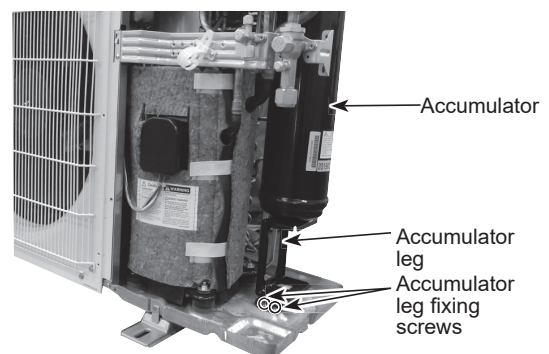
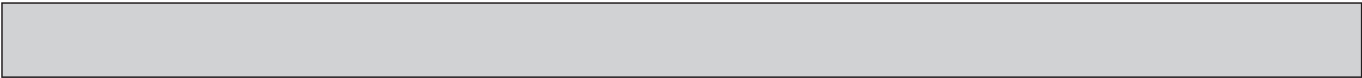
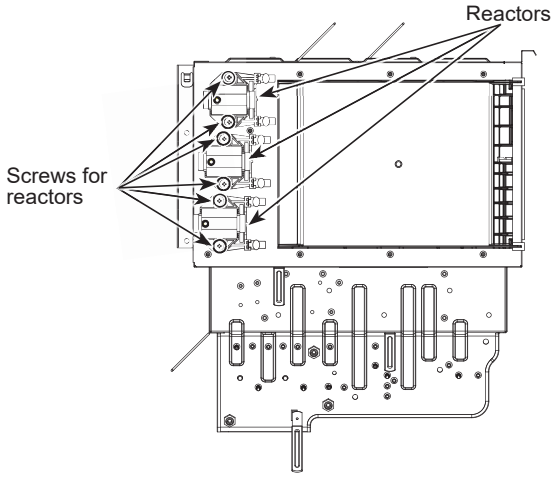
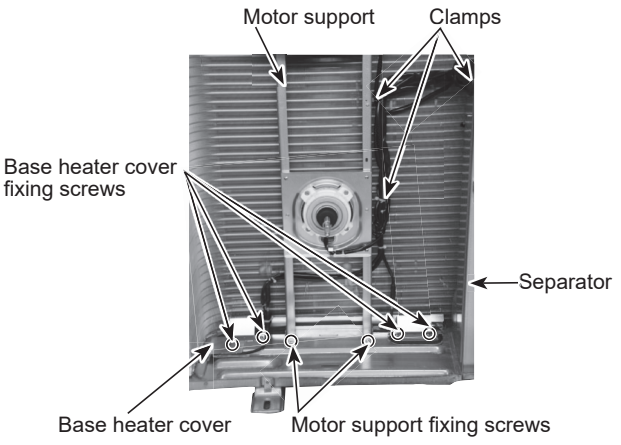
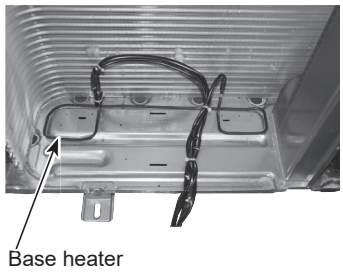

Photo 15





OPERATING PROCEDURE	PHOTOS/FIGURES
<p>15. Removing the reactor (DCL)</p> <ol style="list-style-type: none"> (1) Remove the service panel. (See Photo 1) (2) Remove the top panel. (See Photo 1) (3) Remove the electrical parts box (See Photo 5) (4) Remove 6 screws (4 x 10) for reactor to remove the reactors. (See Figure 3) 	<p>Figure 3</p> 
<p>16. Removing the base heater</p> <ol style="list-style-type: none"> (1) Remove the service panel. (See Photo 1) (2) Remove the top panel. (See Photo 1) (3) Remove 4 fan grille fixing screws (5 x 12) to detach the fan grille. (See Photo 1) (4) Remove a nut (for right handed screw of M6) to detach the propeller. (See Photo 2) (5) Remove all of the following connectors from multi controller circuit board; <Diagram symbol in the connector housing> <ul style="list-style-type: none"> • Fan motor (CNF1, CNF2) • Base heater (SS) Pull out the disconnected wire from the electrical parts box. (See Photo 4) (6) Loosen the wire clamps on the side of the motor support and separator. (7) Remove 2 motor support fixing screws (5 x 12), then remove the motor support with fan motor still attached. (See Photo 16) (8) Remove 4 base heater cover fixing screws (4 x 10), then remove the base heater cover. (9) Remove the base heater. (See Photo 17) <p>Notes:</p> <ol style="list-style-type: none"> 1. Torque the propeller fan to $5.7 \pm 0.3 \text{ N}\cdot\text{m}$ [$4.2 \pm 0.2 \text{ ft} = \text{lbs}$] 2. Rotate the propeller fan and make sure that the base heater and the lead wires do not interfere with the movement of the propeller fan. 	<p>Photo 16</p>  <p>Photo 17</p> 

mitsubishi electric corporation

HEAD OFFICE: TOKYO BUILDING, 2-7-3, MARUNOUCHI, CHIYODA-KU, TOKYO100-8310, JAPAN

©Copyright 2021 MITSUBISHI ELECTRIC CORPORATION
Issued: Nov. 2024 No. OCH789B
Issued: Sep. 2023 No. OCH789A
Published: Nov. 2021 No. OCH789
Made in Japan

Specifications are subject to change without notice.