

# TECHNICAL & SERVICE MANUAL

[Model Name]	[Service Ref.]
(Standard type) PUMY-P36NHMU	PUMY-P36NHMU PUMY-P36NHMUR1 PUMY-P36NHMUR4
PUMY-P48NHMU	PUMY-P48NHMU PUMY-P48NHMU <sub>1</sub> PUMY-P48NHMU <sub>2</sub> PUMY-P48NHMUR3 PUMY-P48NHMUR4
(Salt proof type) PUMY-P36NHMU-BS	PUMY-P36NHMU-BS PUMY-P36NHMUR1-BS PUMY-P36NHMUR4-BS
PUMY-P48NHMU-BS	PUMY-P48NHMU-BS PUMY-P48NHMU <sub>1</sub> -BS PUMY-P48NHMU <sub>2</sub> -BS PUMY-P48NHMUR3-BS PUMY-P48NHMUR4-BS

**Revision:**

- Added a footnote to SW2-1 in "9-5. INTERNAL SWITCH FUNCTION TABLE" in REVISED EDITION-K.
- Some descriptions have been modified.

- Please void OC366 REVISED EDITION-J.

**Notes:**

- This service manual describes technical data of outdoor units only.
- RoHS compliant products have <G> mark on the spec name plate.

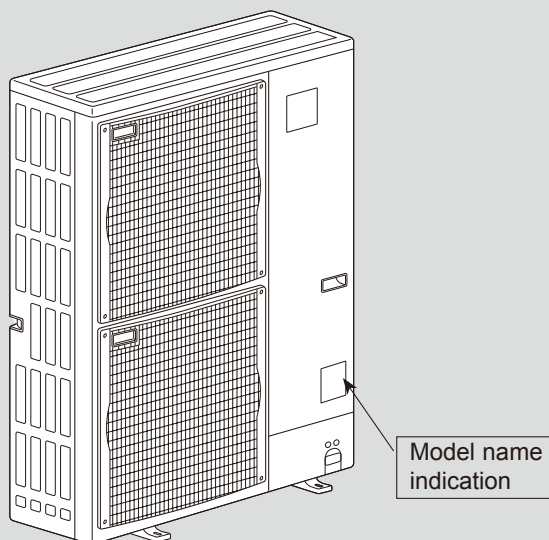

OUTDOOR UNIT

## CONTENTS

1. TECHNICAL CHANGES.....	2
2. SAFETY PRECAUTION.....	5
3. OVERVIEW OF UNITS.....	8
4. SPECIFICATIONS.....	10
5. DATA.....	12
6. OUTLINES AND DIMENSIONS.....	18
7. WIRING DIAGRAM.....	20
8. NECESSARY CONDITIONS FOR SYSTEM CONSTRUCTION.....	24
9. TROUBLESHOOTING.....	34
10. ELECTRICAL WIRING.....	125
11. REFRIGERANT PIPING TASKS.....	128
12. DISASSEMBLY PROCEDURE.....	134
13. PARTS LIST.....	139
14. RoHS PARTS LIST.....	142
15. OPTIONAL PARTS.....	145

**PUMY-P36NHMUR1**      —> **PUMY-P36NHMUR4**  
**PUMY-P36NHMUR1-BS** —> **PUMY-P36NHMUR4-BS**  
**PUMY-P48NHMUR3**     —> **PUMY-P48NHMUR4**  
**PUMY-P48NHMUR3-BS** —> **PUMY-P48NHMUR4-BS**

• Outdoor controller board has been changed (S/W version up) .

**PUMY-P36NHMU**        —> **PUMY-P36NHMUR1**  
**PUMY-P36NHMU-BS**   —> **PUMY-P36NHMUR1-BS**  
**PUMY-P48NHMU<sub>2</sub>**     —> **PUMY-P48NHMUR3**  
**PUMY-P48NHMU<sub>2</sub>-BS** —> **PUMY-P48NHMUR3-BS**

• THERMISTOR has been changed. (Discharge thermistor → Compressor thermistor)  
 • Compressor has been changed.

**PUMY-P48NHMU<sub>1</sub>**       —> **PUMY-P48NHMU<sub>2</sub>**  
**PUMY-P48NHMU<sub>1</sub>-BS** —> **PUMY-P48NHMU<sub>2</sub>-BS**

• Compressor (MC) and oil have been changed.  
 ANB33FDCMT (Ester oil: MEL56)      —>      ANB33FDHMT(Ether oil: FV50S)  
 • Electrical parts have been changed.  
 Multi controller board (MULTI. → C.B.)      Noise filter circuit board (N.F.)  
 Active filter module (ACTM)                      Relay (52C) , Resister (RS) (including N.F.)

**PUMY-P48NHMU**        —> **PUMY-P48NHMU<sub>1</sub>**  
**PUMY-P48NHMU-BS**   —> **PUMY-P48NHMU<sub>1</sub>-BS**

• Primary heating ON/OFF control has been added.

### AUXILIARY HEATING ON/OFF CONTROL SET-UP

(1) Auxiliary heating operation controls another heat source that depends on the main system's operations, which means the interlock operation shown in "c)" will be possible.

- Service ref. PUMY-P48NHMU(-BS) does not have this function.
- Indoor unit must be R410A UL model for this function to operate.
- Different Indoor unit applications that can be applied:

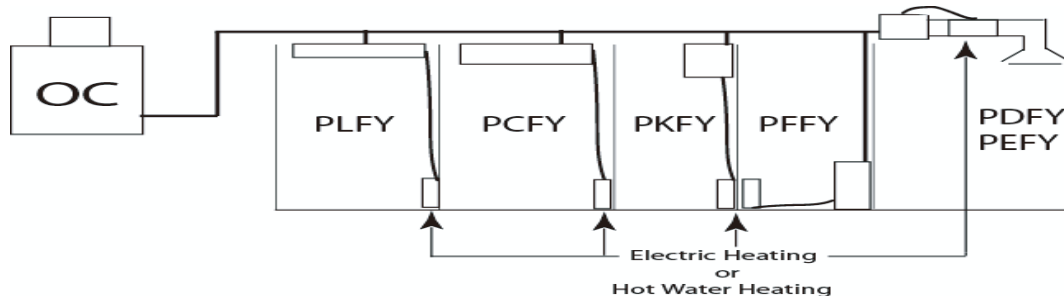

(2) Outdoor unit DIPSW4-4 for auxiliary heating control:

Set DIPSW4-4 when power is turned off at unit.

- OFF:** Disable auxiliary heating function (Initial setting)  
**ON :** Enable auxiliary heating function

**(3) Determine required indoor fans speed during defrost mode:**

- a) With no auxiliary heating output, the indoor fan normally goes off to prevent cold drafts during the defrost cycles.
- b) With auxiliary heating control the auxiliary heat will be on during defrost mode, thus cold drafts will not be present. (Ducted units only)
- c) For models PEFY and PDFY (Ducted), use of "Black" (20K) connector is recommended.
- d) For models PLFY, PCFY, PKFY and PFFY (Ductless), no connector required.
- e) To set the fan airflow rate to be used during defrost operation, insert the resistor that is packed within the optional adaptor cable kit (PAC-YU24HT-F) into the CN22 sensor input.

You can choose at what speed the indoor fan operates during defrost cycles based on the chart below.

Fan airflow rate setting during defrost operation	OFF	ON				Wiring
CN22 input resistance (Ω)	0	20k	27k	39k	62K	
CN22 input (cable color)	None	Black	Blue	White	Red	
Fan speed setting	Stopped	Setting on remote controller	Very Low	Low	High	

Note: The setting will be disabled when heater contact signal is OFF.

**(4) Determine fan airflow setting during indoor thermo OFF conditions:**

- a) These settings are done within indoor DIPSW1-7 and DIPSW1-8, see chart below for options.
- b) Recommended SW1-7 OFF and SW1-8 ON will determine airflow based on setting on the remote controller.

Auxiliary heating signal		Fan speed setting	Fan speed setting	
Thermo condition		OFF	ON	
SW1-7	SW1-8			
OFF	OFF	Very low	Setting on remote controller	
ON	OFF	Low		
OFF	ON	Setting on remote controller		
ON	ON	Stopped		

**(5) Setting outdoor unit and auxiliary heat switch over temperatures.**

When the DIPSW 4-4 is set to "ON", the outdoor unit and the contact output operates as shown below.

- a) Outdoor default setting and operations are shown below:

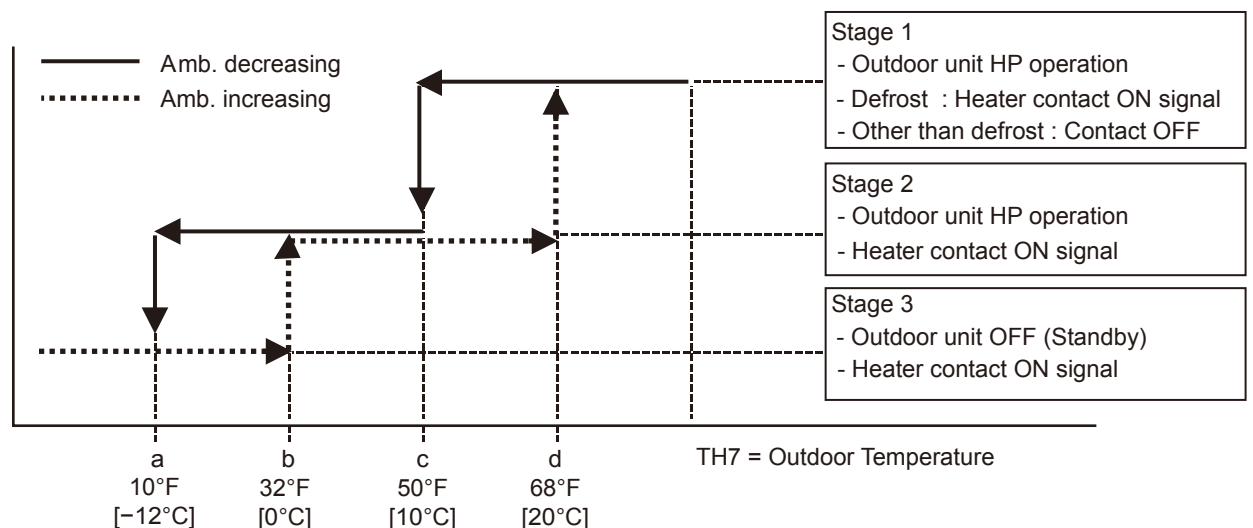

When the set temperature ranges overlap, the previously set pattern (1,2 or 3) has a priority.  
The stage 1 has the highest priority, 2 the second and then 3.

b) Based on above chart listed the sequence of operation on "On Ambient Decrease"

- Stage 1 : (TH7 = > 50°F [10°C]) : The outdoor unit runs in HP mode.
- Stage 2 : (TH7 = 50 to 10°F [10 to -12°C]) : The outdoor unit runs in HP mode with auxiliary heating.
- Stage 3 : (TH7 = < 10°F [-12°C]) : Auxiliary heating only (Outdoor unit is OFF).

c) Based on above chart listed the sequence of operation on " On Ambient Increase"

- Stage 3 : (TH7 = < 32°F [0°C]) : Auxiliary heating only (Outdoor unit is OFF).
- Stage 2 : (TH7 = > 32 to 68°F [0 to 20°C]) : Auxiliary heating with outdoor unit in HP mode.
- Stage 1 : (TH7 = > 68°F [20°C]) : Outdoor unit in HP mode only.

### (6) Locally procured wiring

A basic connection method is shown.

(i.e. interlocked operation with the electric heater with the fan speed setting on high)

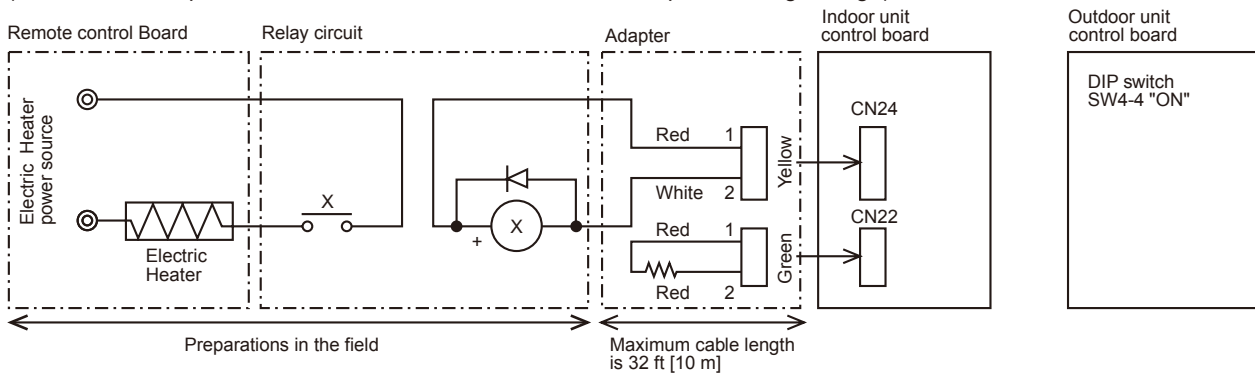

For relay X use the specifications given below operation coil.

Rated voltage: 12 V DC

Power consumption : 0.9 W or less

(Use the diode that is recommended by the relay manufacturer at both ends of the relay coil.)

The length of the electrical wiring for the PAC-YU24HT is 6-1/2 ft [2 m].

To extend this length, use sheathed 2-core cable.

Control cable type: CVV, CVS, CPEV or equivalent.

Cable size: AWG22 to AWG16 [0.5 to 1.25 mm<sup>2</sup>]

Do not extend the cable more than 32 ft [10 m].

Recommended circuit

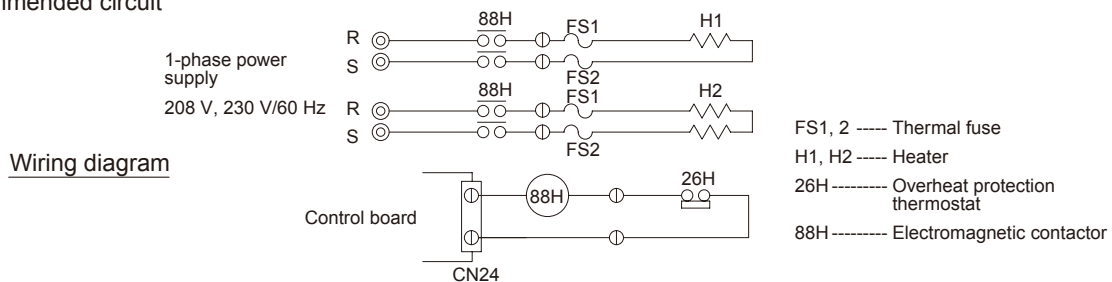

## 2-1. CAUTIONS RELATED TO NEW REFRIGERANT

### Cautions for units utilizing refrigerant R410A

#### Use new refrigerant pipes.

Avoid using thin pipes.

**Make sure that the inside and outside of refrigerant piping is clean and it has no contaminants such as sulfur, oxides, dirt, shaving particles, etc, which are hazards to refrigerant cycle. In addition, use pipes with specified thickness.**

Contamination inside refrigerant piping can cause deterioration of refrigerant oil, etc.

**Store the piping to be used indoors during installation, and both ends of the piping sealed until just before brazing. (Leave elbow joints, etc. in their packaging.)**

If dirt, dust or moisture enters into refrigerant cycle, that can cause deterioration of refrigerant oil or malfunction of compressor.

**The refrigerant oil applied to flare and flange connections must be ester oil, ether oil or alkylbenzene oil in a small amount.**

If large amount of mineral oil enters, that can cause deterioration of refrigerant oil, etc.

**Charge refrigerant from liquid phase of gas cylinder.**

If the refrigerant is charged from gas phase, composition change may occur in refrigerant and the efficiency will be lowered.

**Do not use refrigerant other than R410A.**

If other refrigerant (R22, etc.) is used, chlorine in refrigerant can cause deterioration of refrigerant oil, etc.

**Use a vacuum pump with a reverse flow check valve.**

Vacuum pump oil may flow back into refrigerant cycle and that can cause deterioration of refrigerant oil, etc.

**Use the following tools specifically designed for use with R410A refrigerant.**

The following tools are necessary to use R410A refrigerant.

Tools for R410A	
Gauge manifold	Flare tool
Charge hose	Size adjustment gauge
Gas leak detector	Vacuum pump adaptor
Torque wrench	Electronic refrigerant charging scale

**Handle tools with care.**

If dirt, dust or moisture enters into refrigerant cycle, that can cause deterioration of refrigerant oil or malfunction of compressor.

**Do not use a charging cylinder.**

If a charging cylinder is used, the composition of refrigerant will change and the efficiency will be lowered.

**Use the specified refrigerant only.**

**Never use any refrigerant other than that specified.** Doing so may cause a burst, an explosion, or fire when the unit is being used, serviced, or disposed of. Correct refrigerant is specified in the manuals and on the spec labels provided with our products. We will not be held responsible for mechanical failure, system malfunction, unit breakdown or accidents caused by failure to follow the instructions.

**Ventilate the room if refrigerant leaks during operation. If refrigerant comes into contact with a flame, poisonous gases will be released.**

### [1] Cautions for service

- (1) Perform service after recovering the refrigerant left in unit completely.
- (2) Do not release refrigerant in the air.
- (3) After completing service, charge the cycle with specified amount of refrigerant.
- (4) When performing service, install a filter drier simultaneously.  
Be sure to use a filter drier for new refrigerant.

### [2] Additional refrigerant charge

**When charging directly from cylinder**

- Check that cylinder for R410A on the market is a syphon type.
- Charging should be performed with the cylinder of syphon stood vertically. (Refrigerant is charged from liquid phase.)

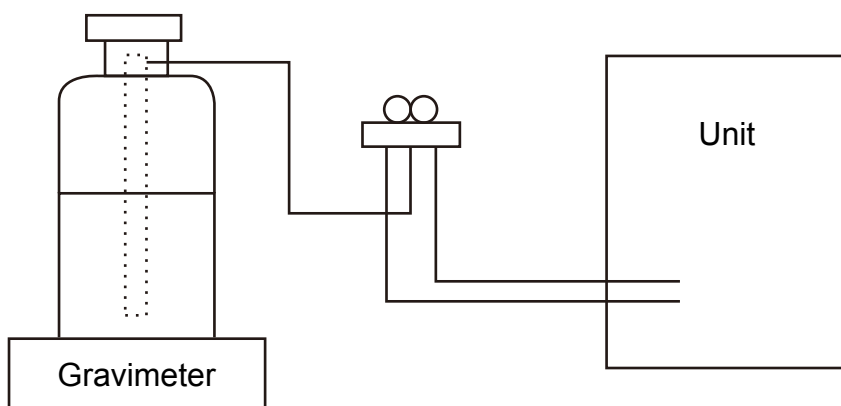

### [3] Service tools

Use the below service tools as exclusive tools for R410A refrigerant.

No.	Tool name	Specifications
①	Gauge manifold	· Only for R410A
		· Use the existing fitting specifications.
		· Use high-tension side pressure of 5.3MPa·G or over.
②	Charge hose	· Only for R410A
		· Use pressure performance of 5.09MPa·G or over.
③	Electronic scale	—
④		· Use the detector for R134a, R407C or R410A.
⑤	Gas leak detector	· Attach on vacuum pump.
⑥	Adaptor for reverse flow check	—
⑦	Refrigerant charge base	· Only for R410A      · Top of cylinder (Pink)
		· Cylinder with syphon
⑧	Refrigerant recovery equipment	—

### 2-2. PRECAUTIONS FOR SALT PROOF TYPE "-BS" MODEL

Although "-BS" model has been designed to be resistant to salt damage, observe the following precautions to maintain the performance of the unit.

1. Avoid installing the unit in a location where it will be exposed directly to seawater or sea breeze.
2. If the cover panel may become covered with salt, be sure to install the unit in a location where the salt will be washed away by rainwater. (If a sunshade is installed, rainwater may not clean the panel.)
3. To ensure that water does not collect in the base of the outdoor unit, make sure that the base is level, not at angle. Water collecting in the base of the outdoor unit could cause rust.
4. If the unit is installed in a coastal area, clean the unit with water regularly to remove any salt build-up.
5. If the unit is damaged during installation or maintenance, be sure to repair it.
6. Be sure to check the condition of the unit regularly.
7. Be sure to install the unit in a location with good drainage.

## 2-3. Cautions for refrigerant piping work

New refrigerant R410A is adopted for replacement inverter series. Although the refrigerant piping work for R410A is same as for R22, exclusive tools are necessary so as not to mix with different kind of refrigerant. Furthermore as the working pressure of R410A is 1.6 times higher than that of R22, their sizes of flared sections and flare nuts are different.

### ① Thickness of pipes

Because the working pressure of R410A is higher compared to R22, be sure to use refrigerant piping with thickness shown below. (Never use pipes of 7/256 inches [0.7 mm] or below.)

Diagram below: Piping diameter and thickness

Nominal dimensions (in)	Outside diameter (mm)	Thickness : in [mm]	
		R410A	R22
1/4	6.35	1/32 [0.8]	1/32 [0.8]
3/8	9.52	1/32 [0.8]	1/32 [0.8]
1/2	12.70	1/32 [0.8]	1/32 [0.8]
5/8	15.88	5/128 [1.0]	5/128 [1.0]
3/4	19.05	—	5/128 [1.0]

### ② Dimensions of flare cutting and flare nut

The component molecules in HFC refrigerant are smaller compared to conventional refrigerants. In addition to that, R410A is a refrigerant, which has higher risk of leakage because its working pressure is higher than that of other refrigerants. Therefore, to enhance airtightness and strength, flare cutting dimension of copper pipe for R410A has been specified separately from the dimensions for other refrigerants as shown below. The dimension B of flare nut for R410A also has partly been changed to increase strength as shown below. Set copper pipe correctly referring to copper pipe flaring dimensions for R410A below. For 1/2 and 5/8 inch pipes, the dimension B changes. Use torque wrench corresponding to each dimension.

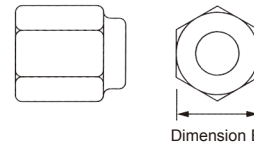
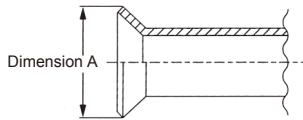

Flare cutting dimensions

Nominal dimensions (in)	Outside diameter (mm)	Dimension A (+0, -0.4)	
		R410A (in [mm])	R22 (mm)
1/4	6.35	11/32-23/64 [9.1]	9.0
3/8	9.52	1/2-33/64 [13.2]	13.0
1/2	12.70	41/64-21/32 [16.6]	16.2
5/8	15.88	49/64-25/32 [19.7]	19.4
3/4	19.05	—	23.3

Flare nut dimensions

Nominal dimensions (in)	Outside diameter (mm)	Dimension B	
		R410A (in [mm])	R22 (mm)
1/4	6.35	43/64 [17.0]	17.0
3/8	9.52	7/8 [22.0]	22.0
1/2	12.70	1-3/64 [26.0]	24.0
5/8	15.88	1-9/64 [29.0]	27.0
3/4	19.05	—	36.0

### ③ Tools for R410A (The following table shows whether conventional tools can be used or not.)

Tools and materials	Use	R410A tools	Can R22 tools be used?	Can R407C tools be used?
Gauge manifold	Air purge, refrigerant charge and operation check	Tool exclusive for R410A	×	×
Charge hose	Air purge, refrigerant charge and operation check	Tool exclusive for R410A	×	×
Gas leak detector	Gas leak check	Tool for HFC refrigerant	×	○
Refrigerant recovery equipment	Refrigerant recovery	Tool exclusive for R410A	×	×
Refrigerant cylinder	Refrigerant charge	Tool exclusive for R410A	×	×
Applied oil	Apply to flared section	Ester oil, ether oil and alkylbenzene oil (minimum amount)	×	Ester oil, ether oil: ○ Alkylbenzene oil: minimum amount
Safety charger	Prevent compressor malfunction when charging refrigerant by spraying liquid refrigerant	Tool exclusive for R410A	×	×
Charge valve	Prevent gas from blowing out when detaching charge hose	Tool exclusive for R410A	×	×
Vacuum pump	Vacuum drying and air purge	Tools for other refrigerants can be used if equipped with adapter for reverse flow check	△ (Usable if equipped with adapter for reverse flow)	△ (Usable if equipped with adapter for reverse flow)
Flare tool	Flaring work of piping	Tools for other refrigerants can be used by adjusting flaring dimension	△ (Usable by adjusting flaring dimension)	△ (Usable by adjusting flaring dimension)
Bender	Bend the pipes	Tools for other refrigerants can be used	○	○
Pipe cutter	Cut the pipes	Tools for other refrigerants can be used	○	○
Welder and nitrogen gas cylinder	Weld the pipes	Tools for other refrigerants can be used	○	○
Refrigerant charging scale	Refrigerant charge	Tools for other refrigerants can be used	○	○
Vacuum gauge or thermistor vacuum gauge and vacuum valve	Check the degree of vacuum. (Vacuum valve prevents back flow of oil and refrigerant to thermistor vacuum gauge)	Tools for other refrigerants can be used	○	○
Charging cylinder	Refrigerant charge	Tool exclusive for R410A	×	—

× : Prepare a new tool. (Use the new tool as the tool exclusive for R410A.)

△ : Tools for other refrigerants can be used under certain conditions.

○ : Tools for other refrigerants can be used.

# 3

# OVERVIEW OF UNITS

## 3-1. UNIT CONSTRUCTION

Outdoor unit		P36	P48
Indoor unit that can be connected	Capacity	Type 06 to Type 36	Type 06 to Type 54
	Number of units	1 to 6 unit	1 to 8 unit
	Total system wide capacity	50 to 130% of outdoor unit capacity	

Branching pipe components	CMY-Y62-G-E	CMY-Y64-G-E	CMY-Y68-G-E
	Branch header (2 branches)	Branch header (4 branches)	Branch header (8 branches)

Model	Ceiling cassette				Ceiling concealed				Ceiling mounted built-in	Wall mounted					
	4-way flow		2-way flow		PEFY-P					PDFY-P	PKFY-P				
	PLFY-P		PLFY-P		PMFY-P		PEFY-P		PKFY-P						
Capacity	NCMU-E	NBMU-E	NLMU-E	NBMU-E	NMLU-E	NHMU-E	NMSU-E	NMAU	NMU-E	NAMU-E	NGMU-E	NFMU-E	NBMU-E	NHMU-E	NKMU-E
06	—	—	○	○	○	—	○	○	○	○	—	—	○	—	—
08	○	—	○	○	○	—	○	○	○	○	—	—	○	—	—
12	○	○	○	○	○	—	○	○	○	—	○	—	—	○	—
15	○	○	○	○	—	○	○	○	○	—	○	—	—	○	—
18	—	○	○	—	—	○	○	○	○	—	—	○	—	○	—
24	—	○	—	—	—	○	○	○	○	—	—	○	—	—	○
27	—	—	—	—	—	○	—	○	○	—	—	—	—	—	—
30	—	○	—	—	—	○	—	○	○	—	—	○	—	—	○
36	—	○	—	—	—	○	—	○	○	—	—	—	—	—	—
48	—	—	—	—	—	○	—	○	○	—	—	—	—	—	—
54	—	—	—	—	—	—	—	○	—	—	—	—	—	—	—

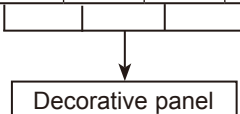

Model	Ceiling suspended		Floor standing		Ceiling concealed (Fresh Air)*	Vertical concealed	
	PCFY-P		PFFY-P			PVFY-P	
	Capacity	NGMU-E	NKMU-E	NEMU-E	NRMU-E	NHMU-E-F	E00A
06	—	—	○	○	—	—	—
08	—	—	○	○	—	—	—
12	—	—	○	○	—	○	○
15	○	○	○	○	—	—	—
18	—	—	○	○	—	○	○
24	○	○	○	○	—	○	○
27	—	—	—	—	—	—	—
30	○	○	—	—	○	○	○
36	○	○	—	—	—	○	○
48	—	—	—	—	—	○	○
54	—	—	—	—	○	○	○

Remote controller	Name	M-NET remote controller	MA remote controller
	Model number	PAR-F27MEA-US	PAR-21MAAU-J, PAR-30MAAU-J
	Functions	<ul style="list-style-type: none"> <li>A handy remote controller for use in conjunction with the Melans centralized management system.</li> <li>Addresses must be set.</li> </ul>	<ul style="list-style-type: none"> <li>Address setting is not necessary.</li> </ul>

\*It is possible only by 1:1 system.

(1 indoor unit of Fresh Air type is connected with 1 outdoor unit.)

Operating temperature range (outdoor temperature) for fresh air type indoor units differ from other indoor units. Refer to "(2) Operating Temperature Range" in "3-2. UNIT SPECIFICATIONS".

## 3-2. UNIT SPECIFICATIONS

### (1) Method for identifying MULTI-S model

#### ■ Indoor unit < When using Model 30 >

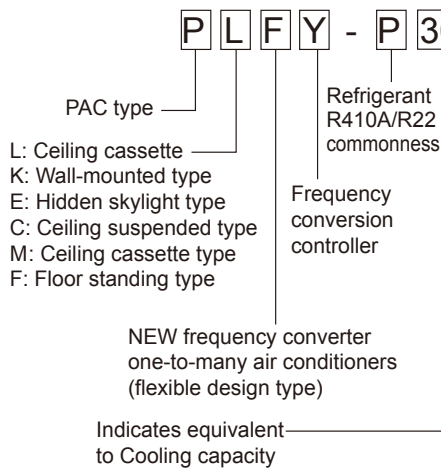

#### ■ Outdoor unit <When using model 48 >

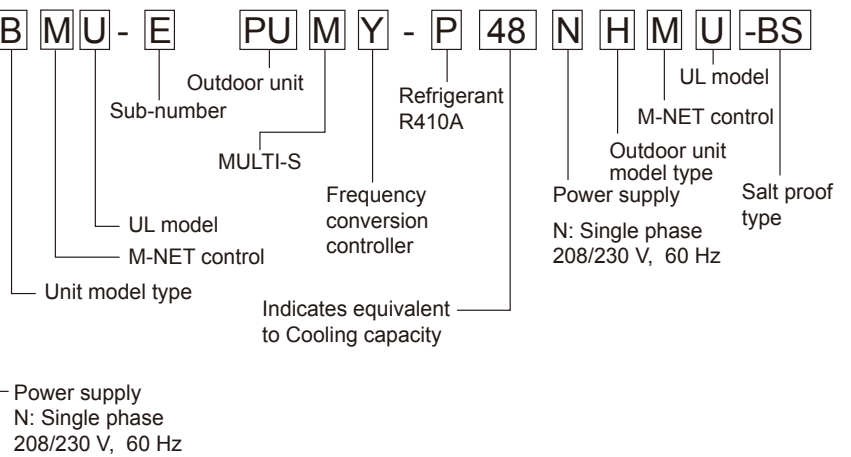

### (2) Operating temperature range

	Cooling	Heating
Indoor-side intake air temperature	W.B. 59 to 75°F [15 to 24°C]	D.B. 59 to 81°F [15 to 27°C]
Outdoor-side intake air temperature	D.B. 23 to 115°F [-5 to 46°C]*	W.B. 0 to 60°F [-18 to 15°C]

Notes: D.B. : Dry Bulb Temperature  
W.B. : Wet Bulb Temperature

\*D.B. 50 to 115°F [D.B. 10 to 46°C]: In case of connecting PKFY-P06/P08 type indoor unit.

#### ■ In case of connecting fresh air type indoor unit

	Capacity of Fresh air type indoor	Cooling	Heating
Indoor-side and Outdoor-side intake air temperature	P30	D.B. 70 to 109°F [21 to 43°C]** W.B. 60 to 95 °F [15.5 to 35°C]	D.B. 14 to 68°F [-10 to 20°C]***
	P54	D.B. 70 to 109°F [21 to 43°C]** W.B. 60 to 95°F [15.5 to 35°C]	D.B. 23 to 68°F [-5 to 20°C]***

\*\*Thermo-OFF (FAN-mode) automatically starts if the outdoor temperature is lower than D.B. 70°F [21°C].

\*\*\*Thermo-OFF (FAN-mode) automatically starts if the outdoor temperature is higher than D.B. 68°F [20°C].

### (3) Guaranteed voltage

198 to 253 V, 60 Hz

# 4

# SPECIFICATIONS

Item		Service Ref.	PUMY-P36NHMU(-BS)	PUMY-P36NHMUR1(-BS) PUMY-P36NHMUR4(-BS)
Cooling Capacity		BTU/h	36,000	
Heating Capacity		BTU/h	40,000	
Input (Cool)*		kW	3.22	
Input Current (Cool)*		A	14.23/15.74	
Power factor (Cool)*		%	98.4	
Input (Heat)*		kW	2.93	
Input Current (Heat)*		A	12.88/14.24	
Power factor (Heat)*		%	98.9	
EER (Cool)*		BTU/h/W	11.18	
COP (Heat)*		W/W	4.00	
Connectable indoor units (Maximum)			6	
Max. Connectable Capacity		BTU/h	46,800 (130%)	
Power Supply			Single phase , 60 Hz , 208/230 V	
Breaker Size			30A	
Max. fuse size			40A	
Min.Circuit Ampacity			26A	
Sound level (Cool/Heat)		dB	49/51	
External finish			Munsell 3Y 7.8/1.1	
Refrigerant control			Linear Expansion Valve	
Compressor			Hermetic	
	Model		ANB33FDHMT	ANB33FDSMT
	Motor output	kW	2.2	
	Capacity control	%	Cooling 41 to 100 Heating 41 to 100	
	Starting method		Inverter	
Crankcase heater		W	—	
Heat exchanger			Plate fin coil (Anti corrosion fin treatment)	
Fan	Fan(drive) × No.		Propeller fan × 2	
	Fan motor output	kW	0.086 + 0.086	
	Airflow	CFM [m³/min]	3,530 [100]	
Dimensions (H×W×D)	W	in [mm]	37-13/32 [950]	
	D	in [mm]	13+1-3/16 [330+30]	
	H	in [mm]	53-5/32 [1,350]	
Weight		lb [kg]	287 [130]	
Refrigerant			R410A	
	Charge	lb [kg]	18.7 [8.5]	
	Oil (Model)	oz [L]	73 [2.3] (FV50S)	
Protection devices	High pressure protection		HP switch	
	Compressor protection		Discharge thermo, Overcurrent detection	Compressor thermo, Overcurrent detection
	Fan motor protection		Overheating/Voltage protection	
Total Piping length (Maximum)		ft [m]	394 [120]	
Farthest		ft [m]	262 [80]	
Max Height difference		ft [m]	164 [50]**	
Chargeless length		ft [m]	164 [50]	
Piping diameter	Liquid	φin [mm]	3/8 [9.52]	
	Gas	φin [mm]	5/8 [15.88]	
Guaranteed operation range		(cool)	D.B. 23 to 115°F [D.B. -5 to 46°C]***	
		(heat)	W.B. 0 to 60°F [W.B. -18 to 15°C]	

**Rating conditions**

Cooling Indoor : D.B. 80°F/ W.B. 67°F  
[D.B. 26.7°C/ W.B. 19.4°C]  
Outdoor : D.B. 95°F [D.B. 35°C]  
Heating Indoor : D.B. 70°F [D.B. 21.1°C]  
Outdoor : D.B. 47°F/ W.B. 43°F  
[D.B. 8.3°C/ W.B. 6.1°C]

\*Electrical data is for only outdoor unit.  
(In case of connecting 2 indoor units of PLFY-P18BM type)  
BTU/h=kW × 3,412 CFM=m³/min × 35.31 lb=kg/ 0.4536  
\*\*70 ft [20 m]: In case of installing outdoor unit lower than indoor unit.  
\*\*\*D.B.50 to 115°F [D.B. 10 to 46°C]: In case of connecting PKFY-P06/P08 type indoor unit.  
Note: Above specification data is subject to rounding variation.

Item		Service Ref.	PUMY-P48NHMU(-BS), PUMY-P48NHMU <sub>1</sub> (-BS), PUMY-P48NHMU <sub>2</sub> (-BS) PUMY-P48NHMUR3(-BS), PUMY-P48NHMUR4(-BS)
Cooling Capacity		BTU/h	48,000
Heating Capacity		BTU/h	54,000
Input (Cool)*		kW	4.97
Input Current (Cool)*		A	24.0/21.7
Power factor (Cool)*		%	99.5
Input (Heat)*		kW	4.88
Input Current (Heat)*		A	23.6/21.3
Power factor (Heat)*		%	99.5
EER (Cool)*		BTU/h/W	9.66
COP (Heat)**		W/W	3.24
Connectable indoor units (Maximum)			8
Max. Connectable Capacity		BTU/h	62,400 (130%)
Power Supply			Single phase , 60 Hz , 208/230 V
Breaker Size			30A
Max. fuse size			40A
Min.Circuit.Ampacity			26A
Sound level (Cool/Heat)		dB	50/52
External finish			Munsell 3Y 7.8/1.1
Refrigerant control			Linear Expansion Valve
Compressor			Hermetic
	Model		ANB33FDCMT(NHMU/NHMU <sub>1</sub> ), ANB33FDHMT(NHMU <sub>2</sub> ), ANB33FDSMT(NHMUR3/NHMUR4)
	Motor output	kW	2.4
	Capacity control	%	Cooling 33 to 100 Heating 33 to 100
	Starting method		Inverter
Crankcase heater		W	—
Heat exchanger			Plate fin coil (Anti corrosion fin treatment)
Fan	Fan(drive) × No.		Propeller fan × 2
	Fan motor output	kW	0.086 + 0.086
	Airflow	CFM [m <sup>3</sup> /min]	3,530 [100]
Dimensions (H×W×D)	W	in [mm]	37-13/32 [950]
	D	in [mm]	13+1-3/16 [330+30]
	H	in [mm]	53-5/32 [1.350]
Weight		lb [kg]	287 [130]
Refrigerant			R410A
	Charge	lb [kg]	18.7 [8.5]
	Oil (Model)	oz [L]	73 [2.3] (MEL56/NHMU <sub>1</sub> ), FV50S/NHMU <sub>2</sub> , NHMUR3, NHMUR4)
Protection devices	High pressure protection		HP switch
	Compressor protection		Discharge thermo, Overcurrent detection(NHMU/NHMU <sub>1</sub> /NHMU <sub>2</sub> ) Compressor thermo, Overcurrent detection(NHMUR3/NHMUR4)
	Fan motor protection		Overheating/Voltage protection
Total Piping length (Maximum)		ft [m]	394 [120]
Farthest		ft [m]	262 [80]
Max Height difference		ft [m]	164 [50]**
Chargeless length		ft [m]	164 [50]
Piping diameter	Liquid	φin [mm]	3/8 [9.52]
	Gas	φin [mm]	5/8 [15.88]
Guaranteed operation range	(cool)		D.B. 23 to 115°F [D.B. -5 to 46°C]***
	(heat)		W.B. 0 to 60°F [W.B. -18 to 15°C]

Rating conditions

Cooling	Indoor	: D.B. 80°F/ W.B. 67°F [D.B. 26.7°C/ W.B. 19.4°C]
	Outdoor	: D.B. 95°F [D.B. 35°C]
Heating	Indoor	: D.B. 70°F [D.B. 21.1°C]
	Outdoor	: D.B. 4°F/ W.B. 43°F [D.B. 8.3°C/ W.B. 6.1°C]

\*Electrical data is for only outdoor unit.

(In case of connecting 2 indoor units of PLFY-P24BM type)  
BTU/h=kW × 3,412 CFM=m<sup>3</sup>/min × 35.31 lb=kg/ 0.4536

\*\*70 ft [20 m] : In case of installing outdoor unit lower than indoor unit.

\*\*\*D.B. 50 to 115°F [D.B.10 to 46°C]: In case of connecting PKFY-P06/P08 type indoor unit.  
Note: Above specification data is subject to rounding variation.

## 5-1. COOLING AND HEATING CAPACITY AND CHARACTERISTICS

### 5-1-1. Method for Obtaining System Cooling and Heating Capacity:

To obtain the system cooling and heating capacity and the electrical characteristics of the outdoor unit, first add up the ratings of all the indoor units connected to the outdoor unit (see table below), and then use this total to find the standard capacity with the help of the tables on "5-3. STANDARD CAPACITY DIAGRAM".

#### (1) Capacity of indoor unit

Model number for indoor unit	Model 06	Model 08	Model 12	Model 15	Model 18	Model 24	Model 27	Model 30	Model 36	Model 48	Model 54
Model Capacity	6	8	12	15	18	24	27	30	36	48	54

#### (2) Sample calculation

- ① System assembled from indoor and outdoor unit (in this example the total capacity of the indoor units is greater than that of the outdoor unit)
- Outdoor unit PUMY-P48NHMU
  - Indoor unit PKFY-P08NAMU-E × 2 , PLFY-P18NLMU-E × 2
- ② According to the conditions in ①, the total capacity of the indoor unit will be:  $8 \times 2 + 18 \times 2 = 52$
- ③ The following figures are obtained from the 52 total capacity row of the standard capacity table in "5-3. STANDARD CAPACITY DIAGRAM":

Capacity (BTU/h)		Outdoor unit power consumption (kW)		Outdoor unit current (A)/230V	
Cooling	Heating	Cooling	Heating	Cooling	Heating
Ⓐ 48,900	Ⓑ 54,500	5.01	4.71	21.9	20.6

### 5-1-2. Method for Obtaining the Heating and Cooling Capacity of an Indoor Unit:

- (1) The capacity of each indoor unit (BTU/h) = the capacity Ⓐ (or Ⓑ) ×  $\frac{\text{model capacity}}{\text{total model capacity of all indoor units}}$

#### (2) Sample calculation (using the system described above in 5-1-1. (2) ):

##### During cooling:

- The total model capacity of the indoor unit is:  
 $8000 \times 2 + 18000 \times 2 = 52000$  BTU/h  
 Therefore, the capacity of PKFY-P08NAMU-E and PLFY-P18NLMU-E will be calculated as follows by using the formula in 5-1-2. (1):

$$\text{Model 08} = 48,900 \times \frac{8000}{52000} = 7,520 \text{ BTU/h}$$

$$\text{Model 18} = 48,900 \times \frac{18000}{52000} = 16,930 \text{ BTU/h}$$

##### During heating:

- The total model capacity of indoor unit is:  
 $9000 \times 2 + 20000 \times 2 = 58000$  BTU/h  
 Therefore, the capacity of PKFY-P08NAMU-E and PLFY-P18NLMU-E will be calculated as follows by using the formula in 5-1-2. (1):

$$\text{Model 08} = 54,500 \times \frac{9000}{58000} = 8,460 \text{ BTU/h}$$

$$\text{Model 18} = 54,500 \times \frac{20000}{58000} = 18,790 \text{ BTU/h}$$

## 5-2. STANDARD OPERATION DATA (REFERENCE DATA)

### 5-2-1. Cooling operation

Operation				Outdoor unit model	
				PUMY-P36NHMU	PUMY-P48NHMU
Operating conditions	Ambient temperature	Indoor	D.B./W.B.	80°F/67°F [26.7°C/19.4°C]	80°F/67°F [26.7°C/19.4°C]
		Outdoor		95°F/— [35°C/—]	95°F/— [35°C/—]
	Indoor unit	No. of connected units	Unit	3	4
		No. of units in operation		3	4
		Model		—	12
	Piping	Main pipe	ft [m]	16-3/8 [5]	16-3/8 [5]
		Branch pipe		8-1/4 [2.5]	8-1/4 [2.5]
		Total pipe length		41 [12.5]	49-1/4 [15]
	Fan speed		—	Hi	Hi
	Amount of refrigerant		lb-oz [kg]	18 [8.5]	18 [8.5]
Outdoor unit	Electric current		A	14.1	19.6
	Voltage		V	230	230
	Compressor frequency		Hz	59	82
LEV opening	Indoor unit		Pulse	271	326
Pressure	High pressure/Low pressure		psi [MPa]	399/136 [2.75/0.94]	444/132 [3.06/0.91]
Temp. of each section	Outdoor unit	Discharge	°F [°C]	149 [65]	167 [75]
		Heat exchanger outlet		106 [42]	115 [46]
		Accumulator inlet		48 [9]	46 [8]
		Compressor inlet		50 [10]	48 [9]
		Compressor shell bottom		156 [69]	174 [79]
	Indoor unit	LEV inlet		84 [29]	90 [32]
		Heat exchanger inlet		52 [11]	54 [12]

### 5-2-2. Heating operation

Operation				Outdoor unit model	
				PUMY-P36NHMU	PUMY-P48NHMU
Operating conditions	Ambient temperature	Indoor	D.B./W.B.	70°F/ — [21.1°C/ —]	70°F/ — [21.1°C/ —]
		Outdoor		47°F/ 43°F [8.3°C/ 6.1°C]	47°F/ 43°F [8.3°C/ 6.1°C]
	Indoor unit	No. of connected units	Unit	3	4
		No. of units in operation		3	4
		Model		—	12
	Piping	Main pipe	ft [m]	16-3/8 [5]	16-3/8 [5]
		Branch pipe		8-1/4 [2.5]	8-1/4 [2.5]
		Total pipe length		41 [12.5]	49-1/4 [15]
	Fan speed		—	Hi	Hi
	Amount of refrigerant		lb-oz [kg]	18 [8.5]	18 [8.5]
Outdoor unit	Electric current		A	16.5	20.8
	Voltage		V	230	230
	Compressor frequency		Hz	65	82
LEV opening	Indoor unit		Pulse	264	312
Pressure	High pressure/Low pressure		psi [MPa]	411/103 [2.83/0.71]	449/94 [3.09/0.65]
Temp. of each section	Outdoor unit	Discharge	°F [°C]	162 [72]	183 [84]
		Heat exchanger outlet		36 [2]	37 [3]
		Accumulator inlet		34 [1]	36 [2]
		Compressor inlet		37 [3]	39 [4]
		Compressor shell bottom		167 [75]	189 [87]
	Indoor unit	LEV inlet		108 [42]	108 [42]
		Heat exchanger inlet		147 [64]	158 [70]

### 5-3. STANDARD CAPACITY DIAGRAM

Before calculating the sum of total capacity of indoor units, please convert the value following the formula on "5-1-1. Method for Obtaining System Cooling and Heating Capacity".

#### 5-3-1. PUMY-P36NHMU(-BS)

#### PUMY-P36NHMUR1(-BS)

#### PUMY-P36NHMUR4(-BS)

Total capacity of indoor units	Capacity(BTU/h)		Power consumption(kW)		Current(A)/230V		Current(A)/208V	
	Cooling	Heating	Cooling	Heating	Cooling	Heating	Cooling	Heating
18	18,000	20,200	1.38	1.45	6.1	6.4	6.8	7.1
19	19,000	21,300	1.45	1.52	6.4	6.7	7.1	7.4
20	20,000	22,400	1.52	1.60	6.7	7.0	7.4	7.8
21	21,000	23,500	1.60	1.67	7.1	7.4	7.8	8.1
22	22,000	24,700	1.68	1.75	7.4	7.7	8.2	8.5
23	23,000	25,800	1.76	1.83	7.8	8.0	8.6	8.9
24	24,000	26,900	1.85	1.91	8.2	8.4	9.0	9.3
25	25,000	28,000	1.94	1.98	8.6	8.7	9.5	9.6
26	26,000	29,200	2.04	2.06	9.0	9.1	9.9	10.0
27	27,000	30,300	2.14	2.15	9.4	9.4	10.4	10.4
28	28,000	31,400	2.24	2.23	9.9	9.8	10.9	10.8
29	29,000	32,500	2.35	2.31	10.4	10.2	11.5	11.2
30	30,000	33,700	2.46	2.40	10.9	10.5	12.0	11.7
31	31,000	34,800	2.58	2.48	11.4	10.9	12.6	12.1
32	32,000	35,900	2.70	2.57	11.9	11.3	13.2	12.5
33	33,000	37,000	2.82	2.66	12.5	11.7	13.8	12.9
34	34,000	38,200	2.95	2.75	13.0	12.1	14.4	13.4
35	35,000	39,300	3.08	2.84	13.6	12.5	15.1	13.8
36	36,000	40,000	3.22	2.93	14.2	12.9	15.7	14.2
37	36,200	40,200	3.23	2.92	14.3	12.9	15.8	14.2
38	36,400	40,400	3.25	2.89	14.3	12.7	15.9	14.1
39	36,600	40,700	3.26	2.86	14.4	12.6	15.9	13.9
40	36,900	40,900	3.27	2.84	14.5	12.5	16.0	13.8
41	37,100	41,100	3.28	2.81	14.5	12.3	16.0	13.6
42	37,300	41,300	3.30	2.78	14.6	12.2	16.1	13.5
43	37,500	41,600	3.31	2.75	14.6	12.1	16.2	13.4
44	37,700	41,800	3.32	2.72	14.7	11.9	16.2	13.2
45	37,900	42,000	3.34	2.69	14.7	11.8	16.3	13.1
46	38,100	42,200	3.35	2.66	14.8	11.7	16.4	12.9

Note: In some combination patterns, numerical value of the heating data may differ slightly.  
(CAPACITY: about several hundred BTU/h)

**5-3-2. PUMY-P48NHMU(-BS)  
PUMY-P48NHMUR3(-BS)**

**PUMY-P48NHMU<sub>1</sub>(-BS)  
PUMY-P48NHMUR4(-BS)**

**PUMY-P48NHMU<sub>2</sub>(-BS)**

Total capacity of indoor units	Capacity(Btu/h)		Power consumption(kW)		Current(A)/230V		Current(A)/208V	
	Cooling	Heating	Cooling	Heating	Cooling	Heating	Cooling	Heating
24	24,000	26,900	2.11	2.32	9.2	10.2	10.2	11.2
25	25,000	28,000	2.20	2.41	9.6	10.5	10.6	11.6
26	26,000	29,200	2.29	2.50	10.0	10.9	11.1	12.1
27	27,000	30,300	2.38	2.59	10.4	11.3	11.5	12.5
28	28,000	31,400	2.48	2.68	10.8	11.7	12.0	13.0
29	29,000	32,500	2.58	2.78	11.3	12.1	12.4	13.4
30	30,000	33,700	2.68	2.87	11.7	12.6	12.9	13.9
31	31,000	34,800	2.78	2.97	12.2	13.0	13.4	14.4
32	32,000	35,900	2.89	3.07	12.6	13.4	14.0	14.8
33	33,000	37,000	3.00	3.17	13.1	13.9	14.5	15.3
34	34,000	38,200	3.11	3.28	13.6	14.3	15.0	15.8
35	35,000	39,300	3.23	3.38	14.1	14.8	15.6	16.3
36	36,000	40,400	3.35	3.49	14.6	15.2	16.2	16.9
37	37,000	41,500	3.47	3.60	15.2	15.7	16.8	17.4
38	38,000	42,700	3.60	3.71	15.7	16.2	17.4	17.9
39	39,000	43,800	3.72	3.82	16.3	16.7	18.0	18.5
40	40,000	44,900	3.85	3.93	16.8	17.2	18.6	19.0
41	41,000	46,000	3.99	4.05	17.4	17.7	19.3	19.6
42	42,000	47,200	4.12	4.17	18.0	18.2	19.9	20.1
43	43,000	48,300	4.26	4.28	18.6	18.7	20.6	20.7
44	44,000	49,400	4.41	4.41	19.3	19.3	21.3	21.3
45	45,000	50,500	4.55	4.53	19.9	19.8	22.0	21.9
46	46,000	51,700	4.70	4.65	20.5	20.3	22.7	22.5
47	47,000	52,800	4.85	4.78	21.2	20.9	23.4	23.1
48	48,000	54,000	4.97	4.88	21.7	21.3	24.0	23.6
49	48,300	54,200	4.98	4.83	21.8	21.1	24.1	23.3
50	48,500	54,300	4.99	4.79	21.8	20.9	24.1	23.2
51	48,700	54,400	5.00	4.75	21.8	20.8	24.1	23.0
52	48,900	54,500	5.01	4.71	21.9	20.6	24.2	22.8
53	49,100	54,600	5.01	4.67	21.9	20.4	24.2	22.6
54	49,300	54,800	5.02	4.63	21.9	20.2	24.3	22.4
55	49,600	54,900	5.03	4.59	22.0	20.1	24.3	22.2
56	49,800	55,000	5.04	4.55	22.0	19.9	24.3	22.0
57	50,000	55,100	5.04	4.51	22.0	19.7	24.4	21.8
58	50,200	55,200	5.05	4.47	22.1	19.5	24.4	21.6
59	50,400	55,300	5.06	4.43	22.1	19.4	24.4	21.4
60	50,600	55,500	5.07	4.39	22.1	19.2	24.5	21.2
61	50,800	55,600	5.07	4.35	22.2	19.0	24.5	21.0
62	51,100	55,700	5.08	4.31	22.2	18.8	24.6	20.8

Note: In some combination patterns, numerical value of the heating data may differ slightly.  
(CAPACITY: about several hundred BTU/h)

## 5-4. CORRECTING COOLING AND HEATING CAPACITY

### 5-4-1. Correcting Changes in Air Conditions

(1) The performance curve charts (Figure 1, 2) show the ratio by the temperature condition change when the rated capacity (total capacity) and the rated input are presumed 1, under standard length (7.6 m [25 ft]) and standard temperature condition.

- Standard conditions:

Rated cooling capacity	Indoor D.B. 80°F/ W.B.67°F [D.B. 26.7°C/ W.B. 19.4°C] Outdoor D.B. 95°F [D.B. 35°C]
Rated heating capacity	Indoor D.B. 70°F [D.B. 21.1°C] Outdoor D.B. 47°F/ W.B.43°F [D.B. 8.3°C/ W.B. 6.1°C]

- Use the rated input and rated power values given in the characteristics table for each indoor unit.
- The input is the single value of the outdoor unit; the input of each indoor unit must be added to obtain the total input.

(2) The capacity of each indoor unit may be obtained by multiplying the total capacity obtained in (1) by the ratio between the individual capacity at the rated time and the total capacity at the rated time.

$$\text{Individual capacity under stated conditions} = \text{total capacity under the stated conditions} \times \frac{\text{individual capacity at the rated time}}{\text{total capacity at the rated time}}$$

(3) Capacity correction factor curve

**Figure 1. Cooling performance curve**

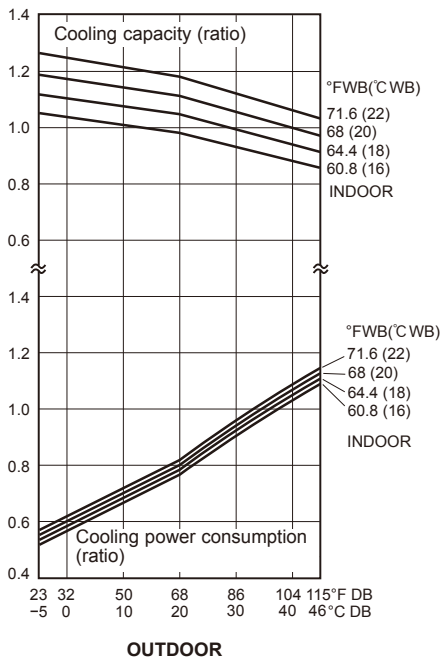

**Figure 2. Heating performance curve**

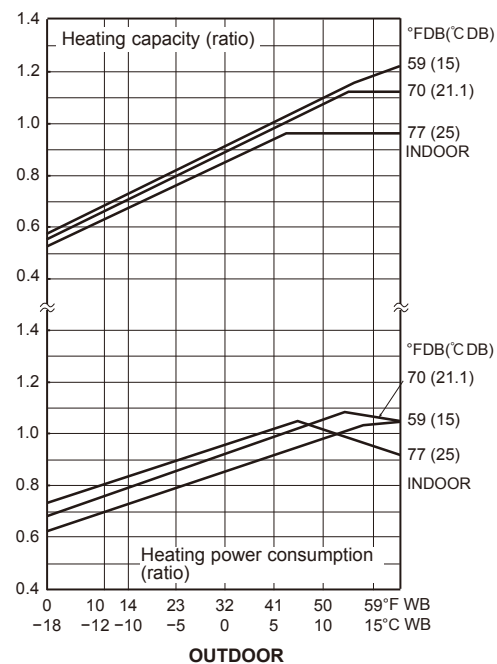

### 5-4-2. Correcting Capacity for Changes in the Length of Refrigerant Piping

- During cooling, to obtain the ratio (and the equivalent piping length) of the outdoor units rated capacity and the total in-use indoor capacity, first find the capacity ratio corresponding to the standard piping length from Figure 3 at first, and then multiply by the cooling capacity from Figure 1 to obtain the actual capacity.
- During heating, to find the equivalent piping length, first find the capacity ratio corresponding to standard piping length from Figure 3, and then multiply by the heating capacity from Figure 2 to obtain the actual capacity.

**(1) Capacity CORRECTION CURVE (Figure 3)**

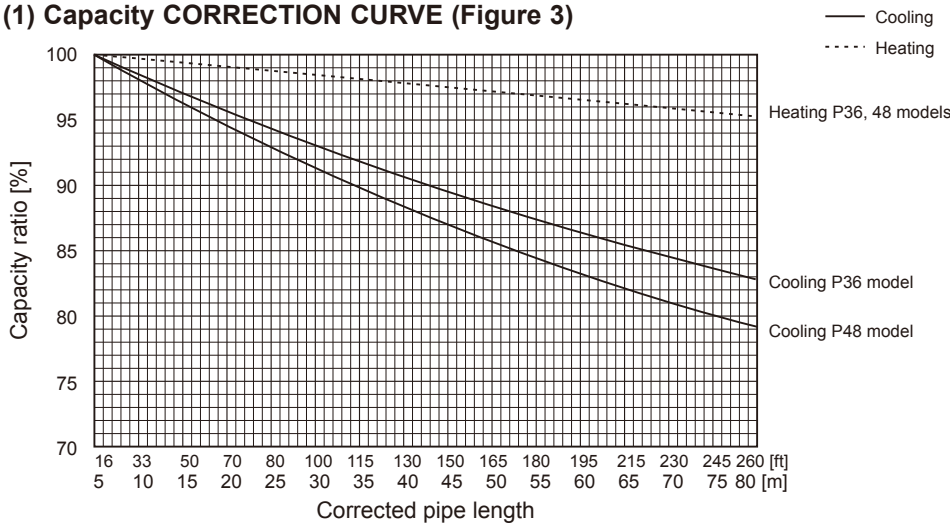

**(2) Method for Obtaining the Equivalent Piping Length**

Equivalent length for type P48 = (length of piping to farthest indoor unit) + (0.3 × number of bends in the piping) (m)  
 Length of piping to farthest indoor unit: 262 ft [80 m]

**5-4-3. Correction of Heating Capacity for Frost and Defrosting**

If heating capacity has been reduced due to frost formation or defrosting, multiply the capacity by the appropriate correction factor from the following table to obtain the actual heating capacity.

**Correction factor diagram**

Outdoor Intake temperature (W.B. °F)	43	39	36	32	28	25	21	18	14
Outdoor Intake temperature (W.B. °C)	6	4	2	0	-2	-4	-6	-8	-10
Correction factor	1.0	0.98	0.89	0.88	0.89	0.9	0.95	0.95	0.95

**5-5. NOISE CRITERION CURVES**

	MODE	SPL(dB)	LINE
PUMY-P36NHMU(-BS)	COOLING	49	○—○
PUMY-P36NHMUR1(-BS)	HEATING	51	●—●
PUMY-P36NHMUR4(-BS)			

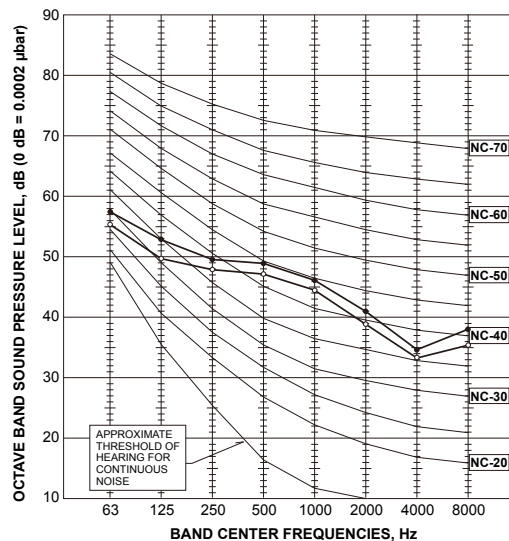

	MODE	SPL(dB)	LINE
PUMY-P48NHMU(-BS)	COOLING	50	○—○
PUMY-P48NHMU <sub>1</sub> (-BS)	HEATING	52	●—●
PUMY-P48NHMU <sub>2</sub> (-BS)			
PUMY-P48NHMUR3(-BS)			
PUMY-P48NHMUR4(-BS)			

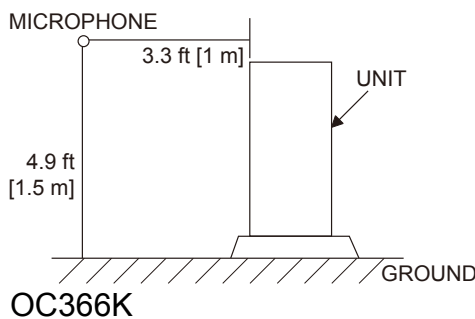
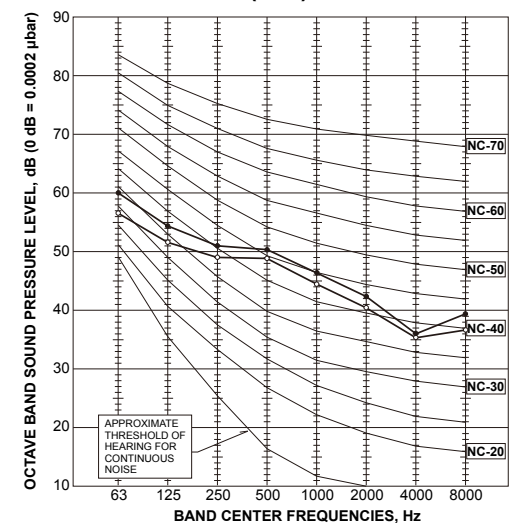





PUMY-P48NHMU PUMY-P48NHMU-BS PUMY-P48NHMU<sub>1</sub> PUMY-P48NHMU<sub>1</sub>-BS

SYMBOL	NAME	SYMBOL	NAME	SYMBOL	NAME
TB1	Terminal Block <Power Supply>	MULTI.B.	Multi Controller Board	N.F.	Noise Filter Circuit Board
TB3	Terminal Block <Transmission>	F1,F2	Fuse<6.3A>	LI/LO	Connection Lead<L-Phase>
TB7	Terminal Block <Centralized Control>	F500	Fuse<3A>	NI/NO	Connection Lead<N-Phase>
MC	Motor for Compressor	SW1	Switch<Display Selection>	EI	Connection Terminal<Ground>
MF1,MF2	Fan Motor	SW2	Switch<Function Selection>	CNAC1/2	Connector
21S4	Solenoid Valve<Four way valve>	SW3	Switch<Test Run>	CN5	Connector
SV1	Solenoid Valve<Bypass valve>	SW4	Switch<Model Selection>	M-P.B.	Transmission Power Board
TH3	Thermistor<Outdoor Pipe Temperature>	SW5	Switch<Function Selection>	CN1	Connector<To Noise Filter Circuit Board>
TH4	Thermistor<Discharge Temperature>	SW6	Switch<Function Selection>	CN2	Connector<To Multi Controller Board>
TH6	Thermistor<Low Pressure Saturated Temperature>	SW7	Switch<Function Selection>		
TH7	Thermistor<Outdoor Temperature>	SW8	Switch<Function Selection>		
TH8	Thermistor<Heatsink>	SWU1	Switch<Unit Address Selection, 1s digit>		
63HS	High Pressure Sensor<Discharge Pressure>	SWU2	Switch<Unit Address Selection, 10ths digit>		
63H	High Pressure Switch	TRANS	Transformer		
63L	Low Pressure Switch	LED1,2	Digital Indicator<Operation Inspection Display>		
CB	Main Smoothing Capacitor	LED3	LED<Power Supply to Main Microcomputer>		
ACTM	Active filter Module	CNS1	Connector<Multi System>		
RS	Rush Current Protect Resistor	CNS2	Connector<Centralized Control>		
DCL	Reactor	CNAC	Connector<To Noise Filter Circuit Board>		
P.B.	Power Circuit Board	CNDC	Connector<Power circuit board>		
U/V/W	Connection Terminal<U/V/W-Phase>	CN2	Connector<To Power Circuit Board>		
TAB-S/T	Terminal<L/N-Phase>	CN4	Connector<To Power Circuit Board>		
TAB-P/P1/P2	Terminal<DCVoltage>	CN40	Connector<Centralized Control Power Supply>		
TAB-N/N1/N2	Terminal<DCVoltage>	CN41	Connector<For storing Jumper Connector>		
CN2~5	Connector	TH3	Connector<Thermistor>		
CNDC	Connector	TH4	Connector<Thermistor>		
CNAF	Connector	TH7/6	Connector<Thermistor>		
IPM	Inverter	63HS	Connector<High Pressure Sensor>		
LED1	Light Emitting Diodes <Inverter Control Status>	63H	Connector<High Pressure Switch>		
		63L	Connector<Low Pressure Switch>		
		CNF1,CNF2	Connector<Fan Motor>		
		21S4	Connector<Four-way Valve>		
		SV1	Connector<Bypass Valve>		
		SS	Connector<For Option>		
		CN3D	Connector<For Option>		
		CN3S	Connector<For Option>		
		CN3N	Connector<For Option>		
		CN51	Connector<For Option>		
		X501~505	Relay		

## Caution for electrical work

Use copper supply wires.

## Cautions when Servicing

- ⚠ WARNING: When the main supply is turned off, the voltage [340 V] in the main capacitor will drop to 20 V in approx. 2 minutes (input voltage: 240 V).  
 When servicing, make sure that LED1, LED2 on the outdoor circuit board goes out, and then wait for at least 1 minute.  
 Components other than the outdoor board may be faulty: Check and take corrective action, referring to the service manual.  
 Do not replace the outdoor board without checking.

## NOTES:

- 1.Refer to the wiring diagrams of the indoor units for details on wiring of each indoor unit.  
 Self-diagnosis function  
 The indoor and outdoor units can be diagnosed automatically using the self-diagnosis switch (SW1) and LED1, LED2 (LED indication) found on the multi-controller of the outdoor unit.  
 LED indication : Set all contacts of SW1 to OFF.

During normal operation

The LED indicates the drive state of the controller in the outdoor unit.

Bit	1	2	3	4	5	6	7	8
Indication	Compressor operated	52C	21S4	SV1	(SV2)	-	-	Always lit

When faults requiring inspection occurs

The LED alternately indicates the inspection code and the location of the unit in which the fault has occurred.

[Example]  
 When the compressor and SV1 are turned during cooling operation.

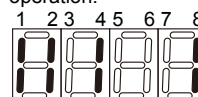

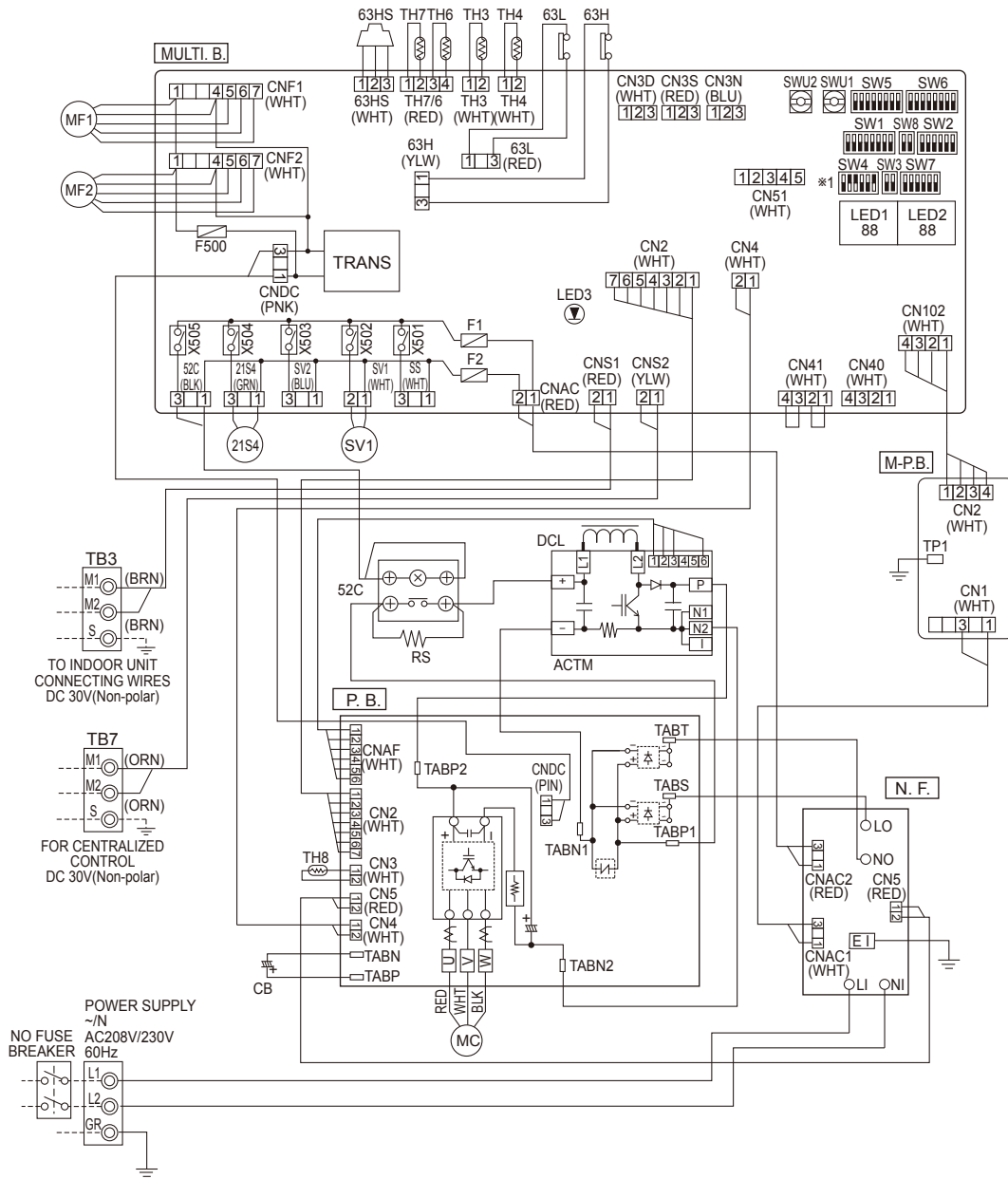

<※1 MODEL SELECT>

MODELS	SW4
PUMY-P48NHMU	<div style="display: flex; align-items: center;"> <span style="font-size: 8px; margin-right: 2px;">ON</span> </div> <div style="display: flex; align-items: center;"> <span style="font-size: 8px; margin-right: 2px;">OFF</span> </div>

The black square (■) indicates a switch position.

(Note : Only PUMY-P48NHMU<sub>1</sub> and PUMY-P48NHMU<sub>1</sub>-BS)

DIP SW4-4 for primary heating control : Set DIP SW4-4 when power is turned off at unit.

DIP SW4-4 OFF : Disable primary heating function (Initial setting)

DIP SW4-4 ON : Enable primary heating function

**PUMY-P36NHMU(-BS)    PUMY-P36NHMUR1(-BS)    PUMY-P36NHMUR4(-BS)**  
**PUMY-P48NHMU<sub>2</sub>(-BS)    PUMY-P48NHMUR3(-BS)    PUMY-P48NHMUR4(-BS)**

SYMBOL	NAME	SYMBOL	NAME	SYMBOL	NAME
TB1	Terminal Block <Power Supply>	P.B.	Power Circuit Board	SW6	Switch<Function Selection>
TB3	Terminal Block <Communication Line>	TABU/V/W	Connection Terminal<U/V/W-Phase>	SW7	Switch<Function Selection>
TB7	Terminal Block <Centralized Control Line>	TABS/T	Connection Terminal<L/N-Phase>	SW8	Switch<Function Selection>
MC	Motor For Compressor	TABP1/P2/P	Connection Terminal<DC Voltage>	SWU1	Switch<Unit Address Selection, 1st digit>
MF1,MF2	Fan Motor	TABN1/N2/N	Connection Terminal<DC Voltage>	SWU2	Switch<Unit Address Selection, 2nd digit>
21S4	Solenoid Valve<Four-Way Valve>	DS2,DS3	Diode Bridge	CNLVB	Connector<To N.F. Board CN52C> (Symbol of Board is CNLVB)
63H	High Pressure Switch	IPM	Power Module	SS	Connector<Connection For Option>
63L	Low Pressure Switch	N.F.	Noise Filter Circuit Board	CN3D	Connector<Connection For Option>
63HS	High Pressure Sensor	LI/L0	Connection Terminal<L-Phase>	CN3S	Connector<Connection For Option>
SV1	Solenoid Valve<Bypass valve>	NI/NO	Connection Terminal<N-Phase>	CN3N	Connector<Connection For Option>
TH3	Thermistor<Outdoor Pipe>	E1,E2	Connection Terminal<Ground>	CN51	Connector<Connection For Option>
TH4	Thermistor<Discharge/Compressor>	52C	52C Relay	LED1,LED2	LED<Operation Inspection Display>
TH6	Thermistor<Low Pressure Saturated>	C.B.	Controller Circuit Board	LED3	LED<Power Supply to Main Microprocessor>
TH7	Thermistor<Outdoor>	SW1	Switch<Display Selection>	F1,F2	Fuse<T6,3AL250V>
TH8	Thermistor<Heatsink>	SW2	Switch<Function Selection>	X501~505	Relay
DCL	Reactor	SW3	Switch<Test Run>	M-NET P.B.	M-NET Power Circuit Board
ACTM	Active Filter Module	SW4	Switch<Model Selection>	TP1	ConnectionTerminal<Ground>
CE	Main Smoothing Capacitor	SW5	Switch<Function Selection>		

**Caution for electrical work**

- Use copper supply wires.

**Cautions when Servicing**

- ⚠ **WARNING:** When the main supply is turned off, the voltage [340 V] in the main capacitor will drop to 20 V in approx. 2 minutes (input voltage: 230 V). When servicing, make sure that LED1, LED2 on the outdoor circuit board goes out, and then wait for at least 1 minute.
- Components other than the outdoor board may be faulty: Check and take corrective action, referring to the service manual. Do not replace the outdoor board without checking.

**NOTES:**

1.Refer to the wiring diagrams of the indoor units for details on wiring of each indoor unit.

**Self-diagnosis function**

The indoor and outdoor units can be diagnosed automatically using the self-diagnosis switch (SW1) and LED1, LED2 (LED indication) found on the multi-controller of the outdoor unit.

LED indication : Set all contacts of SW1 to OFF.

- During normal operation
- The LED indicates the drive state of the controller in the outdoor unit.

Bit	1	2	3	4	5	6	7	8
Indication	Compressor operated	52C	21S4	SV1	(SV2)	-	-	Always lit

- When faults requiring inspection occurs  
The LED alternately indicates the inspection code and the location of the unit in which the fault has occurred.

**[Example]**

When the compressor and SV1 are turned during cooling operation.



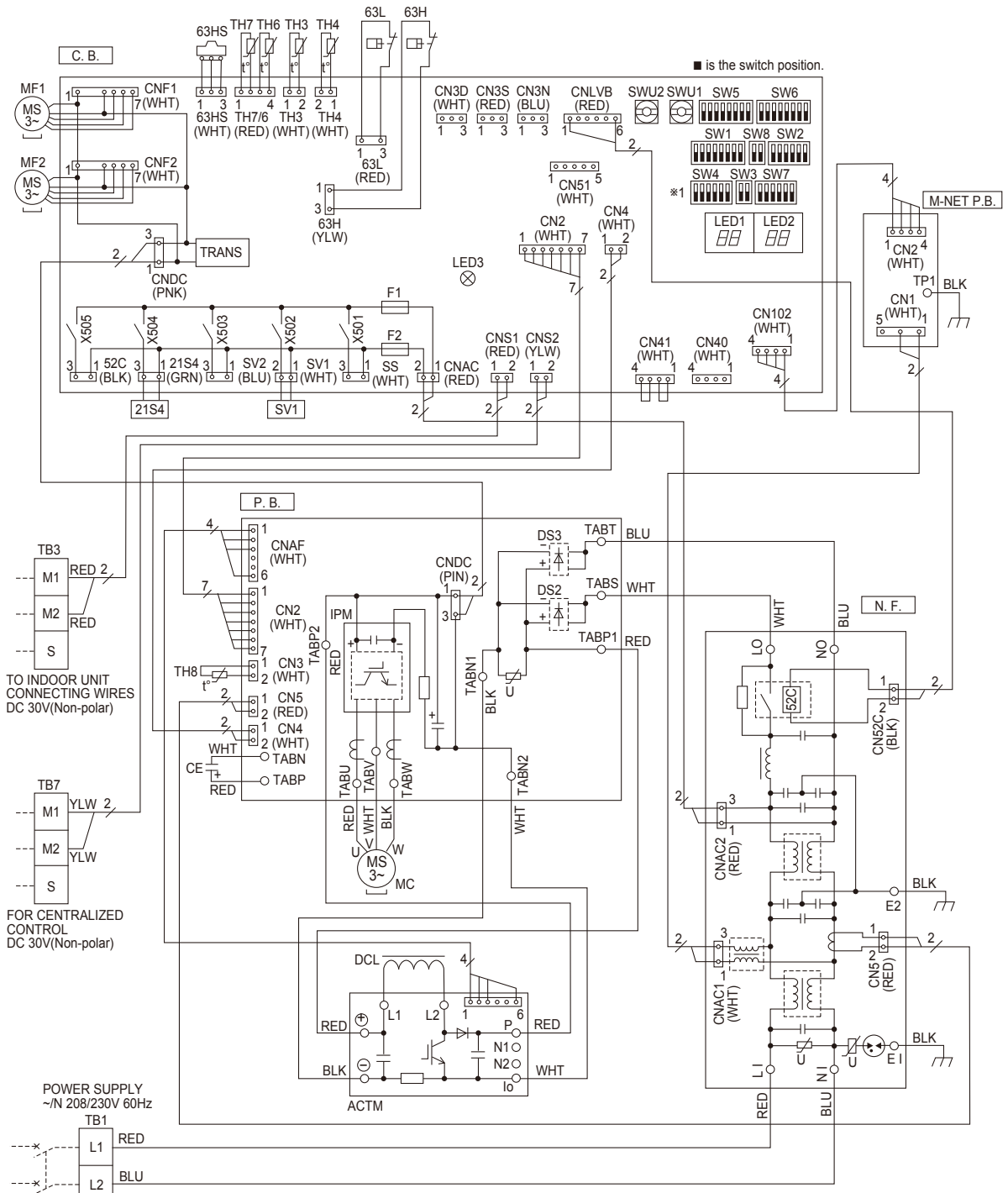

※1 MODEL SELECT 1:ON 0:OFF

MODELS	SW4					
	1	2	3	4	5	6
PUMY-P36NHMU	0	1	1	0	1	0
PUMY-P48NHMU	0	1	1	0	0	1

8-1. TRANSMISSION SYSTEM SETUP

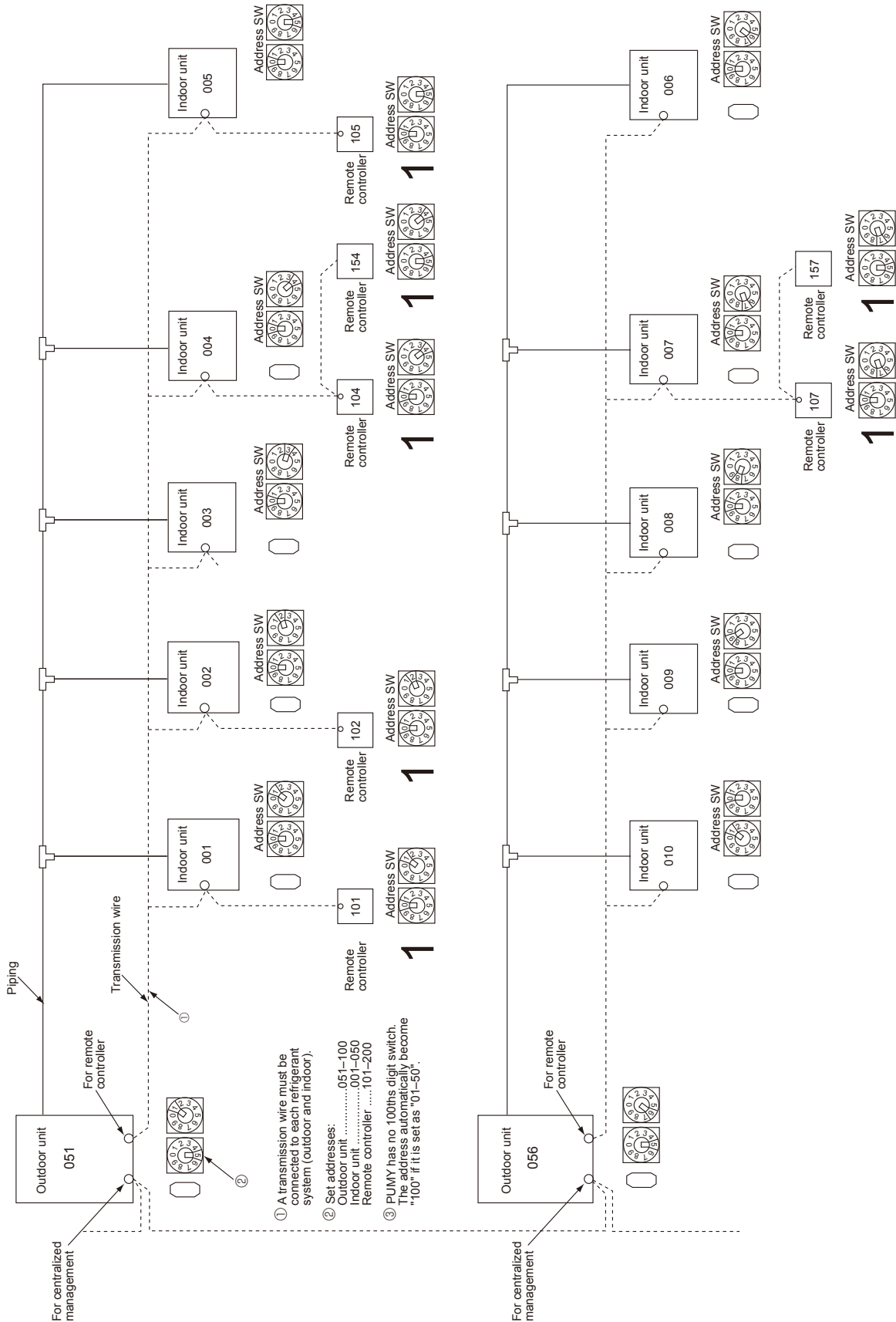

## 8-2. REFRIGERANT SYSTEM DIAGRAM

PUMY-P36NHMU(-BS)

PUMY-P48NHMU(-BS)

PUMY-P48NHMUR3(-BS)

PUMY-P36NHMUR1(-BS)

PUMY-P48NHMU<sub>1</sub>(-BS)

PUMY-P48NHMUR4(-BS)

PUMY-P36NHMUR4(-BS)

PUMY-P48NHMU<sub>2</sub>(-BS)

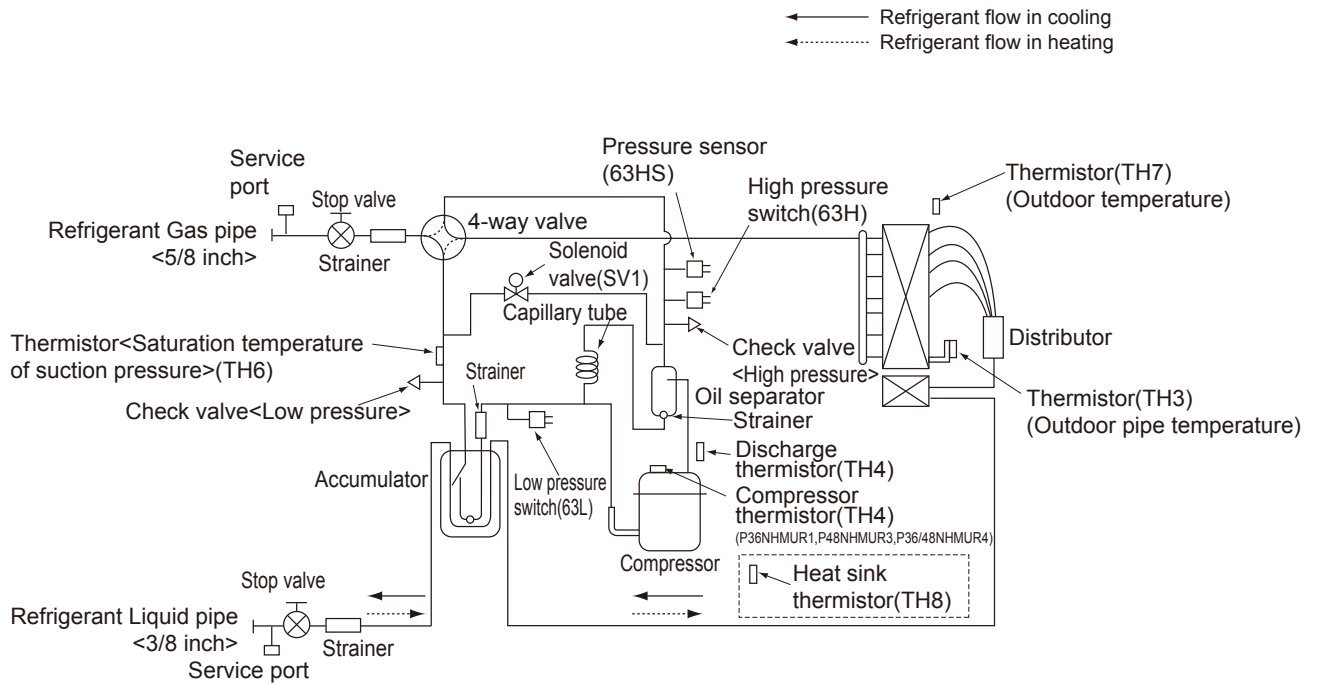

Capillary tube (for oil separator) :  $\phi(3/32) \times \phi(1/32) \times L(39-1/2)$  (in) [ $\phi 2.5 \times \phi 0.8 \times L1000$  (mm) ]

Refrigerant piping specifications <dimensions of flared connector>

Unit: in<mm>

Capacity		Item	Liquid piping	Gas piping
Indoor unit	P06, P08, P12, P15, P18		$\phi 1/4$ <6.35>	$\phi 1/2$ <12.7>
	P24, P30, P36, P48, P54		$\phi 3/8$ <9.52>	$\phi 5/8$ <15.88>
Outdoor unit	P36, P48		$\phi 3/8$ <9.52>	$\phi 5/8$ <15.88>

## 8-3. SYSTEM CONTROL

- Example for wiring control cables, wiring method and address setting, permissible lengths, and the prohibited items are listed in the standard system with detailed explanation.

The explanation for the system in this section : Use 1 single outdoor unit and multiple outdoor units for M-NET remote control system.

Use 1 single outdoor unit and multiple indoor units in the multiple outdoor units for the M-NET remote control system.

### A. Example of a M-NET remote controller system (address setting is necessary.)

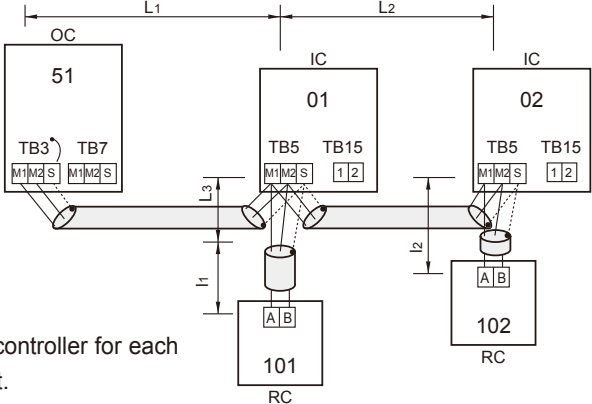
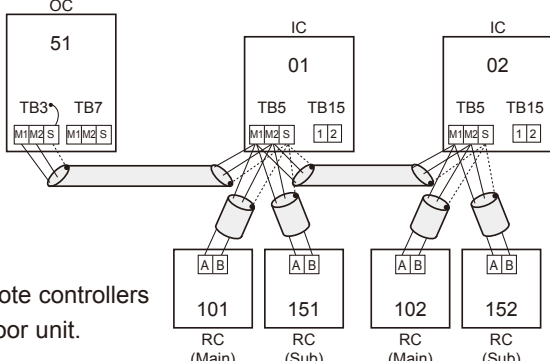
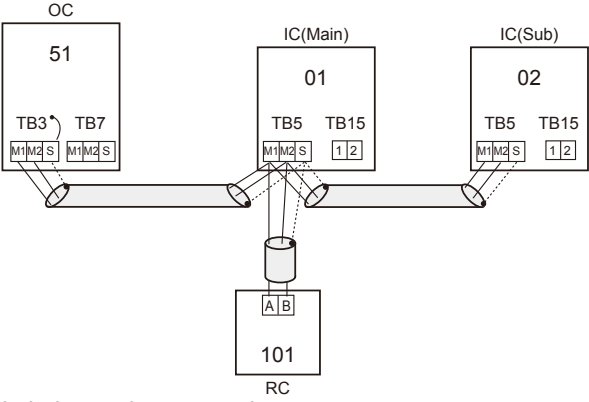
Example of wiring control cables	Wiring Method and Address Setting																				
<p>1. Standard operation</p>  <ul style="list-style-type: none"> <li>• 1 remote controller for each indoor unit.</li> <li>• There is no need for setting the 100 position on the remote controller.</li> </ul>	<p>a. Use feed wiring to connect terminals M1 and M2 on transmission cable block (TB3) for the outdoor unit (OC) to terminals M1 and M2 on the transmission cable block (TB5) of each indoor unit (IC). Use non-polarized 2-core wire.</p> <p>b. Connect terminals M1 and M2 on transmission cable terminal block (TB5) for each indoor unit with the terminal block (TB6) for the remote controller (RC).</p> <p>c. Set the address setting switch (on outdoor unit P.C.B) as shown below.</p> <table border="1" data-bbox="837 744 1439 959"> <thead> <tr> <th>Unit</th> <th>Range</th> <th>Setting Method</th> </tr> </thead> <tbody> <tr> <td>Indoor unit (IC)</td> <td>001 to 050</td> <td>—</td> </tr> <tr> <td>Outdoor unit (OC)</td> <td>051 to 100</td> <td>Use the smallest address of all the indoor unit plus 50.</td> </tr> <tr> <td>Remote controller (RC)</td> <td>101 to 150</td> <td>Indoor unit address plus 100.</td> </tr> </tbody> </table>			Unit	Range	Setting Method	Indoor unit (IC)	001 to 050	—	Outdoor unit (OC)	051 to 100	Use the smallest address of all the indoor unit plus 50.	Remote controller (RC)	101 to 150	Indoor unit address plus 100.						
Unit	Range	Setting Method																			
Indoor unit (IC)	001 to 050	—																			
Outdoor unit (OC)	051 to 100	Use the smallest address of all the indoor unit plus 50.																			
Remote controller (RC)	101 to 150	Indoor unit address plus 100.																			
<p>2. Operation using 2 remote controllers</p>  <ul style="list-style-type: none"> <li>• Using 2 remote controllers for each indoor unit.</li> </ul>	<p>a. Same as above a</p> <p>b. Same as above b</p> <p>c. Set address switch (on outdoor unit P.C.B) as shown below.</p> <table border="1" data-bbox="837 1085 1439 1372"> <thead> <tr> <th>Unit</th> <th>Range</th> <th>Setting Method</th> </tr> </thead> <tbody> <tr> <td>Indoor Unit (IC)</td> <td>001 to 050</td> <td>—</td> </tr> <tr> <td>Outdoor unit (OC)</td> <td>051 to 100</td> <td>Use the smallest address of all the indoor units plus 50.</td> </tr> <tr> <td>Main Remote Controller (RC)</td> <td>101 to 150</td> <td>Indoor unit address plus 100.</td> </tr> <tr> <td>Sub Remote Controller (RC)</td> <td>151 to 200</td> <td>Indoor unit address plus 150.</td> </tr> </tbody> </table>			Unit	Range	Setting Method	Indoor Unit (IC)	001 to 050	—	Outdoor unit (OC)	051 to 100	Use the smallest address of all the indoor units plus 50.	Main Remote Controller (RC)	101 to 150	Indoor unit address plus 100.	Sub Remote Controller (RC)	151 to 200	Indoor unit address plus 150.			
Unit	Range	Setting Method																			
Indoor Unit (IC)	001 to 050	—																			
Outdoor unit (OC)	051 to 100	Use the smallest address of all the indoor units plus 50.																			
Main Remote Controller (RC)	101 to 150	Indoor unit address plus 100.																			
Sub Remote Controller (RC)	151 to 200	Indoor unit address plus 150.																			
<p>3. Group operation</p>  <ul style="list-style-type: none"> <li>• Multiple indoor units operated together by 1 remote controller</li> </ul>	<p>a. Same as above</p> <p>b. Connect terminals M1 and M2 on transmission cable terminal block (TB5) of the IC main unit with the most recent address within the same indoor unit (IC) group to terminal block (TB6) on the remote controller.</p> <p>c. Set the address setting switch (on outdoor unit P.C.B) as shown below.</p> <table border="1" data-bbox="837 1585 1439 1893"> <thead> <tr> <th>Unit</th> <th>Range</th> <th>Setting Method</th> </tr> </thead> <tbody> <tr> <td>IC (Main)</td> <td>001 to 050</td> <td>Use the smallest address within the same group of indoor units.</td> </tr> <tr> <td>IC (Sub)</td> <td>001 to 050</td> <td>Use an address, other than that of the IC (Main) from among the units within the same group of indoor units. This must be in sequence with the IC (Main).</td> </tr> <tr> <td>Outdoor Unit</td> <td>051 to 100</td> <td>Use the smallest address of all the indoor units plus 50.</td> </tr> <tr> <td>Main Remote Controller</td> <td>101 to 150</td> <td>Set at an IC (Main) address within the same group plus 100.</td> </tr> <tr> <td>Sub Remote Controller</td> <td>151 to 200</td> <td>Set at an IC (Main) address within the same group plus 150.</td> </tr> </tbody> </table> <p>d. Use the indoor unit (IC) within the group with the most functions as the IC (Main) unit.</p>			Unit	Range	Setting Method	IC (Main)	001 to 050	Use the smallest address within the same group of indoor units.	IC (Sub)	001 to 050	Use an address, other than that of the IC (Main) from among the units within the same group of indoor units. This must be in sequence with the IC (Main).	Outdoor Unit	051 to 100	Use the smallest address of all the indoor units plus 50.	Main Remote Controller	101 to 150	Set at an IC (Main) address within the same group plus 100.	Sub Remote Controller	151 to 200	Set at an IC (Main) address within the same group plus 150.
Unit	Range	Setting Method																			
IC (Main)	001 to 050	Use the smallest address within the same group of indoor units.																			
IC (Sub)	001 to 050	Use an address, other than that of the IC (Main) from among the units within the same group of indoor units. This must be in sequence with the IC (Main).																			
Outdoor Unit	051 to 100	Use the smallest address of all the indoor units plus 50.																			
Main Remote Controller	101 to 150	Set at an IC (Main) address within the same group plus 100.																			
Sub Remote Controller	151 to 200	Set at an IC (Main) address within the same group plus 150.																			
<p>Combinations of 1 through 3 above are possible.</p>																					

• Name, Symbol and the Maximum Remote controller Units for Connection

Name	Symbol	Maximum units for connection
Outdoor unit	OC	—
Indoor unit	IC	1 OC unit can be connected to 1 to 6 (P36)/1 to 8 (P48) IC units
M-NET remote controller	RC	Maximum 2 RC for 1 indoor unit, Maximum 12 RC for 1 OC

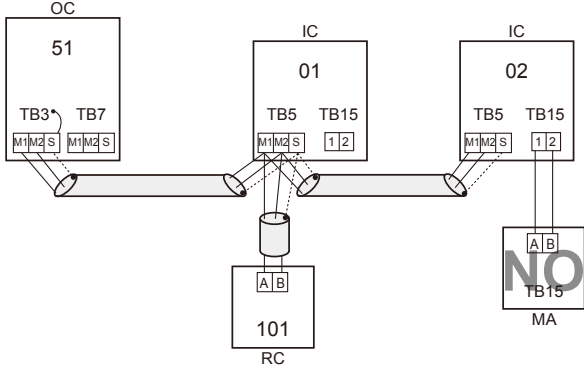
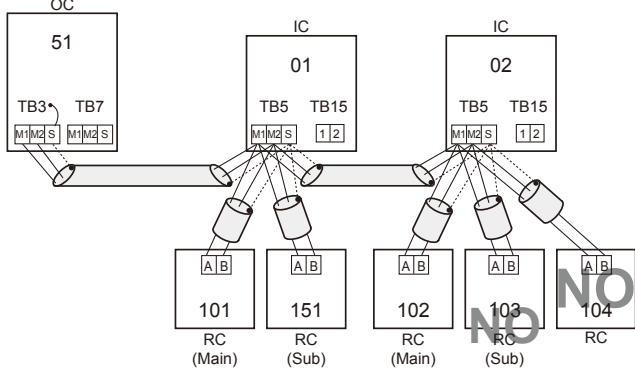
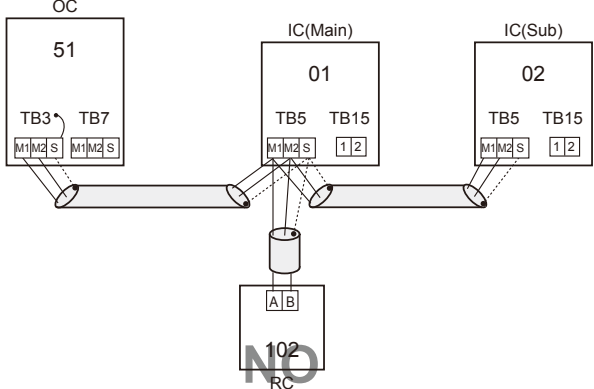
Permissible Lengths	Prohibited items
<p>Longest transmission cable length (1.25 mm<sup>2</sup>)  <math>L_1 + L_2, L_2 + L_3, L_3 + L_1 \leq 200</math> m                      Remote controller cable length                      1. If 0.5 to 1.25 mm<sup>2</sup>  <math>l_1, l_2 \leq 10</math> m                      2. If the length exceeds 10 m, the exceeding section should be 1.25 mm<sup>2</sup> and that section should be a value within the total extension length of the transmission cable and maximum transmission cable length. (L3)</p>	<ul style="list-style-type: none"> <li>M-NET remote controller (RC) and MA remote controller (MA) cannot be used together.</li> <li>Do not connect anything with TB15 of indoor unit (IC).</li> </ul> 
Same as above	 <ul style="list-style-type: none"> <li>Use the indoor unit (IC) address plus 150 as the sub remote controller address. In this case, it should be 152.</li> <li>3 or more remote controllers (RC) cannot be connected to 1 indoor unit.</li> </ul>
Same as above	 <ul style="list-style-type: none"> <li>The remote controller address is the indoor unit main address plus 100. In this case, it should be 101.</li> </ul>

B. Example of a group operation system with 2 or more outdoor units and a M-NET remote controller.  
 (Address settings are necessary.)

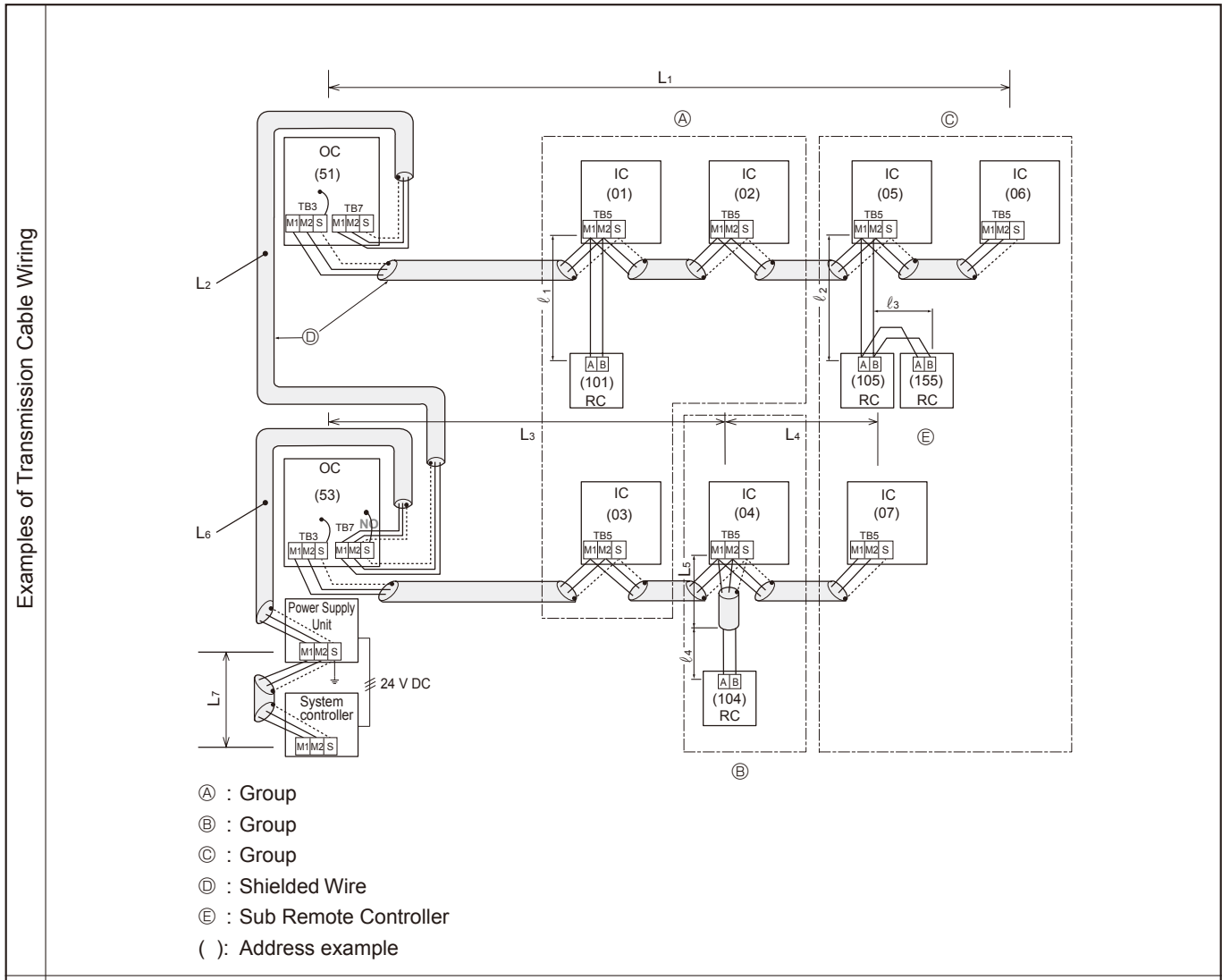

- Wiring Method Address Settings
- Always use shielded wire when making connections between the outdoor unit (OC) and the indoor unit (IC), as well for all OC-OC, and IC-IC wiring intervals.
  - Use feed wiring to connect terminals M1 and M2 and the ground terminal on the transmission cable terminal block (TB3) of each outdoor unit (OC) to terminals M1 and M2 on the terminal S on the transmission cable block of the indoor unit (IC).
  - Connect terminals M1 and M2 on the transmission cable terminal block of the indoor unit (IC) that has the most recent address within the same group to the terminal block on the remote controller (RC).
  - Connect together terminals M1, M2 and terminal S on the terminal block for centralized control (TB7) for the outdoor unit (OC).
  - DO NOT change the jumper connector CN41 on MULTI controller board.
  - The earth processing of S terminal for the centralized control terminal block (TB7) is unnecessary. Connect the terminal S on the power supply unit with the earth.
  - Set the address setting switch as follows.
- | Unit                   | Range      | Setting Method                                                                                                             |
|------------------------|------------|----------------------------------------------------------------------------------------------------------------------------|
| IC (Main)              | 01 to 00   | Use the smallest address within the same group of indoor units.                                                            |
| IC (Sub)               | 01 to 50   | Use an address, other than the IC (Main) in the same group of indoor units. This must be in sequence with the IC (Main).   |
| Outdoor Unit           | 51 to 100  | Use the smallest address of all the indoor units plus 50. The address automatically becomes "100" if it is set as "01-50". |
| Main Remote Controller | 101 to 150 | Set at an IC (Main) address within the same group plus 100.                                                                |
| Sub Remote Controller  | 151 to 200 | Set at an IC (Main) address within the same group plus 150.                                                                |
| MA Remote Controller   | —          | Address setting is not necessary. (Main/sub setting is necessary.)                                                         |
- The group setting operations among the multiple indoor units is done by the remote controller (RC) after the electrical power has been turned on.

• Name, Symbol, and the Maximum Units for Connection

**Permissible Length**

- Longest length via outdoor units :  $L_1+L_2+L_3+L_4, L_1+L_2+L_3+L_5, L_1+L_2+L_6+L_7 \leq 500 \text{ m}$  ( $1.25 \text{ mm}^2$ )
- Longest transmission cable length :  $L_1, L_3+L_4, L_3+L_5, L_6, L_2+L_6, L_7 \leq 200 \text{ m}$  ( $1.25 \text{ mm}^2$ )
- Remote controller cable length :  $l_1, l_2, l_2+l_3, l_4 \leq 10 \text{ m}$  ( $0.5 \text{ to } 1.25 \text{ mm}^2$ )

If the length exceeds 10 m, use a  $1.25 \text{ mm}^2$  shielded wire. The length of this section ( $L_8$ ) should be included in the calculation of the maximum length and overall length.

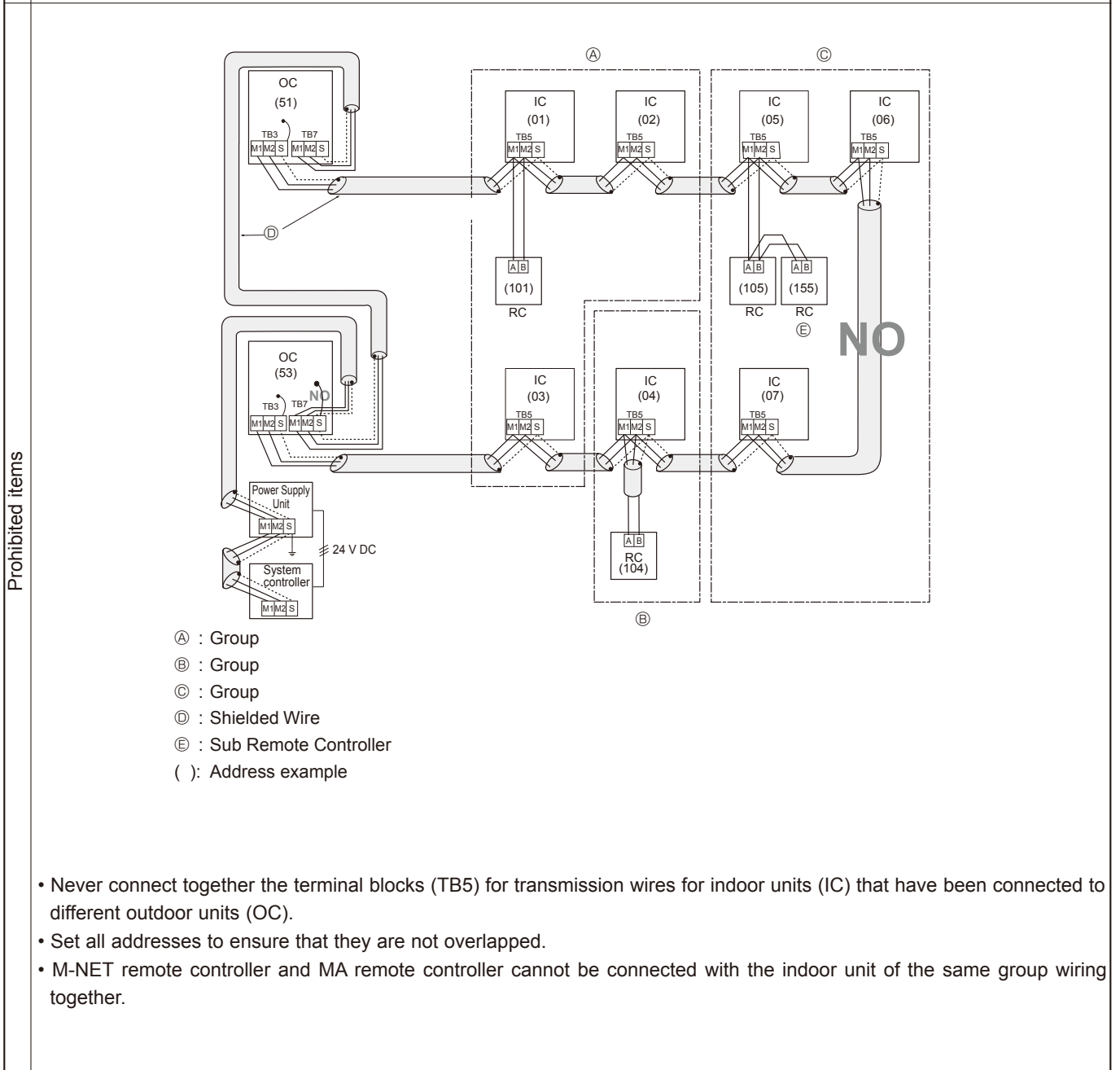

C. Example of a MA remote controller system (address setting is not necessary.)

NOTE : In the case of same group operation, need to set the address that is only main indoor unit.

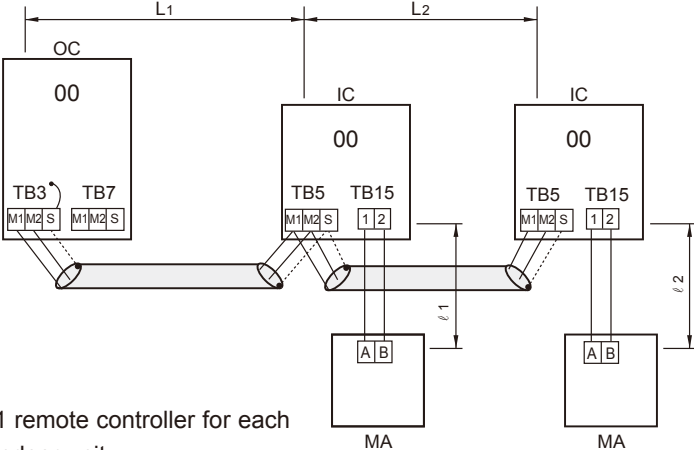
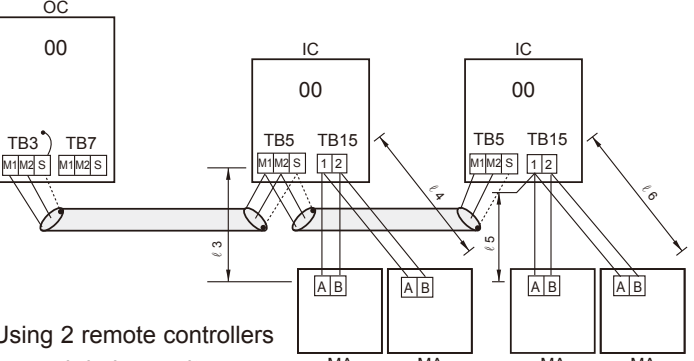
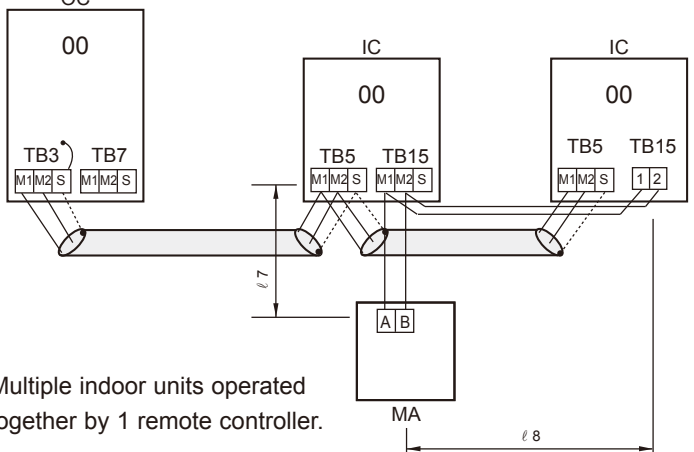
Example of wiring control cables	Wiring Method and Address Setting
<p>1. Standard operation</p>  <p>• 1 remote controller for each indoor unit.</p>	<p>a. Use feed wiring to connect terminals M1 and M2 on transmission cable block (TB3) for the outdoor unit (OC) to terminals M1 and M2 on the transmission cable block (TB5) of each indoor unit (IC). Use non-polarized 2-core wire.</p> <p>b. Connect terminals 1 and 2 on transmission cable terminal block (TB15) for each indoor unit with the terminal block for the MA remote controller (MA).</p>
<p>2. Operation using two remote controllers</p>  <p>• Using 2 remote controllers for each indoor unit.</p>	<p>a. The same as above a</p> <p>b. The same as above b</p> <p>c. In the case of using 2 remote controllers, connect terminals 1 and 2 on transmission cable terminal block (TB15) for each indoor unit with the terminal block for 2 remote controllers.</p> <p>· Set either one of the MA remote controllers to "sub remote controller"</p> <p>Refer to the installation manual of MA remote controller.</p>
<p>3. Group operation</p>  <p>• Multiple indoor units operated together by 1 remote controller.</p>	<p>a. The same as above a</p> <p>b. The same as above b</p> <p>c. Connect terminals 1 and 2 on transmission cable terminal block (TB15) of each indoor unit, which is doing group operation with the terminal block the MA remote controller. Use non-polarized 2-core wire.</p> <p>d. In the case of same group operation, need to set the address that is only main indoor unit. Please set the smallest address within number 01–50 of the indoor unit with the most functions in the same group.</p>
<p>Combinations of 1 through 3 above are possible.</p>	

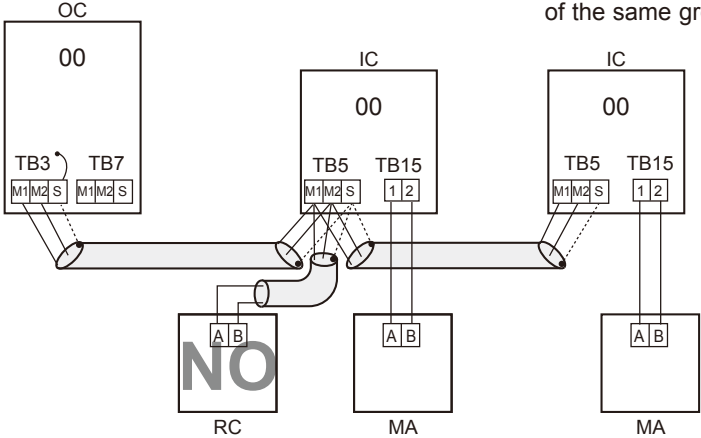
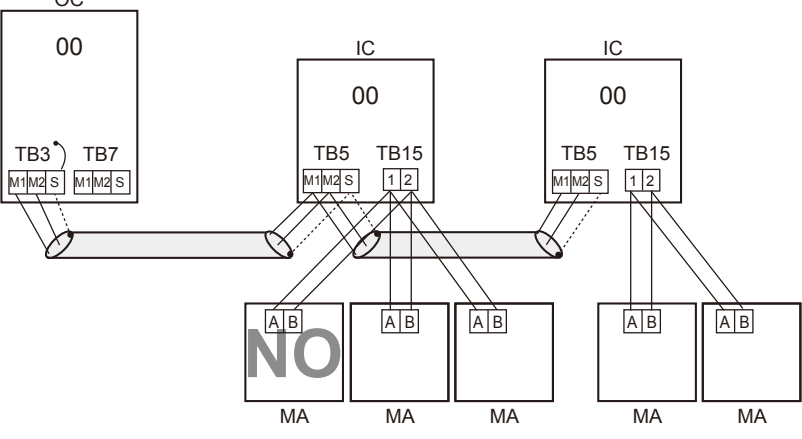
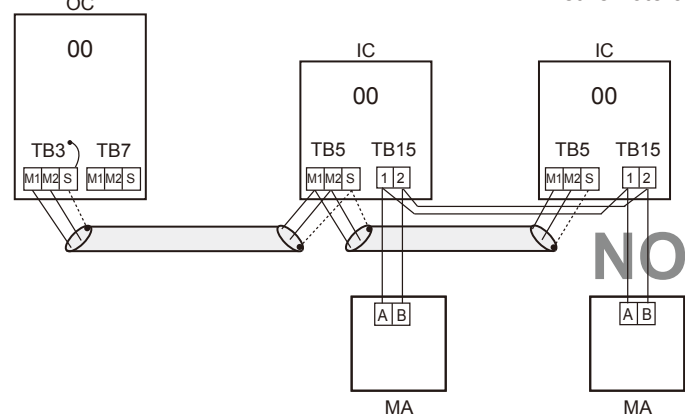
Permissible Lengths	Prohibited items
<p>Longest transmission cable length:  <math>L_1 + L_2 \leq 200 \text{ m}</math> (1.25 mm<sup>2</sup>)</p> <p>MA remote controller cable length:  <math>l_1, l_2 \leq 200 \text{ m}</math> (0.3 to 1.25 mm<sup>2</sup>)</p>	<p>The MA remote controller and the M-NET remote controller cannot be used together with the indoor unit of the same group.</p> 
<p>Longest transmission cable length:  <math>L_1 + L_2 \leq 200 \text{ m}</math> (1.25 mm<sup>2</sup>)</p> <p>MA remote controller cable length:  <math>l_3 + l_4, l_5 + l_6 \leq 200 \text{ m}</math>  (0.3 to 1.25 mm<sup>2</sup>)</p>	<p>3 MA remote controllers or more cannot be connected with the indoor unit of the same group.</p> 
<p>Longest transmission cable length:  <math>L_1 + L_2 \leq 200 \text{ m}</math> (1.25 mm<sup>2</sup>)</p> <p>MA remote controller cable length:  <math>l_7 + l_8 \leq 200 \text{ m}</math> (0.3 to 1.25 mm<sup>2</sup>)</p>	<p>The second MA remote controller is connected with the terminal block (TB15) for the MA remote controller of the same indoor unit (IC) as the first remote control.</p> 

D. Example of a group operation with 2 or more outdoor units and a MA remote controller.  
 (Address settings are necessary.)

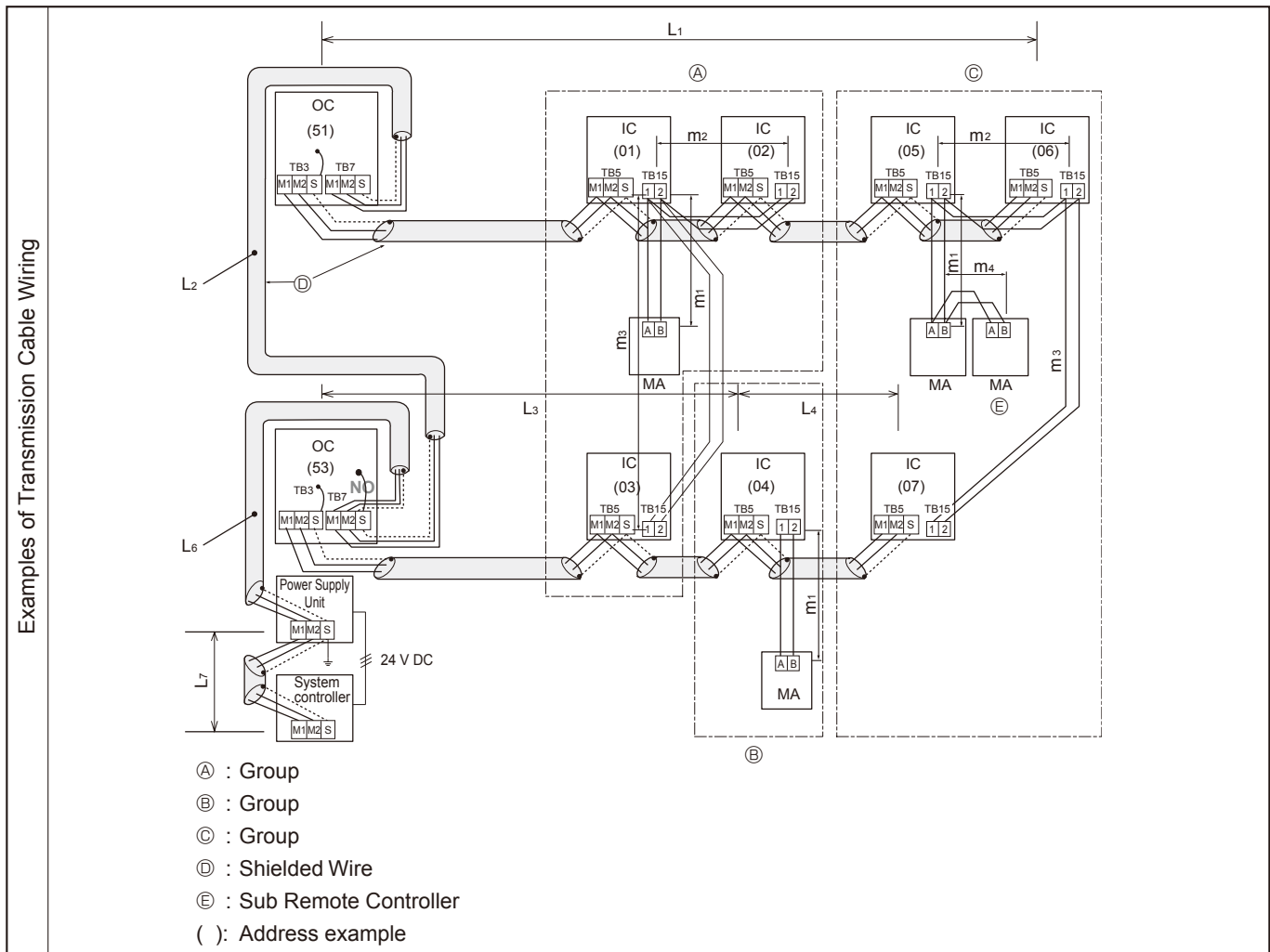

- Wiring Method Address Settings
- Always use shielded wire when making connections between the outdoor unit (OC) and the indoor unit (IC), as well for all OC-OC, and IC-IC wiring intervals.
  - Use feed wiring to connect terminals M1 and M2 and the ground terminal on the transmission cable terminal block (TB3) of each outdoor unit (OC) to terminals M1 and M2 on the terminal S on the transmission cable block of the indoor unit (IC).
  - Connect terminals M1 and M2 on the transmission cable terminal block of the indoor unit (IC) that has the most recent address within the same group to the terminal block on the remote controller (RC).
  - Connect together terminals M1, M2 and terminal S on the terminal block for centralized control (TB7) for the outdoor unit (OC).
  - DO NOT change the jumper connector CN41 on MULTI controller board.
  - The earth processing of S terminal for the centralized control terminal block (TB7) is unnecessary. Connect the terminal S on the power supply unit with the earth.
  - Set the address setting switch as follows.
- | Unit                   | Range      | Setting Method                                                                                                             |
|------------------------|------------|----------------------------------------------------------------------------------------------------------------------------|
| IC (Main)              | 01 to 00   | Use the smallest address within the same group of indoor units.                                                            |
| IC (Sub)               | 01 to 50   | Use an address, other than the IC (Main) in the same group of indoor units. This must be in sequence with the IC (Main).   |
| Outdoor Unit           | 51 to 100  | Use the smallest address of all the indoor units plus 50. The address automatically becomes "100" if it is set as "01-50". |
| Main Remote Controller | 101 to 150 | Set at an IC (Main) address within the same group plus 100.                                                                |
| Sub Remote Controller  | 151 to 200 | Set at an IC (Main) address within the same group plus 150.                                                                |
| MA Remote Controller   | —          | Address setting is not necessary. (Main/sub setting is necessary.)                                                         |
- The group setting operations among the multiple indoor units is done by the remote controller (RC) after the electrical power has been turned on.
  - When connecting PWFY unit
    - For PWFY series, do not set up group connection with other indoor units.
    - LOSSNAY is not available for use with PWFY series.
    - Use a WMA remote controller for operation of PWFY series.
- For more details, refer to the service manual for PWFY series.

• Name, Symbol, and the Maximum Units for Connection

Permissible Length

Longest length via outdoor unit (M-NET cable):  $L_1+L_2+L_3+L_4$  and  $L_1+L_2+L_6+L_7 \leq 500$  m (1.25 mm<sup>2</sup> more)  
 Longest transmission cable length (M-NET cable):  $L_1$  and  $L_3+L_4$  and  $L_6$  and  $L_2+L_6$  and  $L_7 \leq 200$  m (1.25 mm<sup>2</sup> or more)  
 Remote controller cable length:  $m_1$  and  $m_1+m_2+m_3$  and  $m_1+m_2+m_3+m_4 \leq 200$  m (0.3 to 1.25 mm<sup>2</sup>)

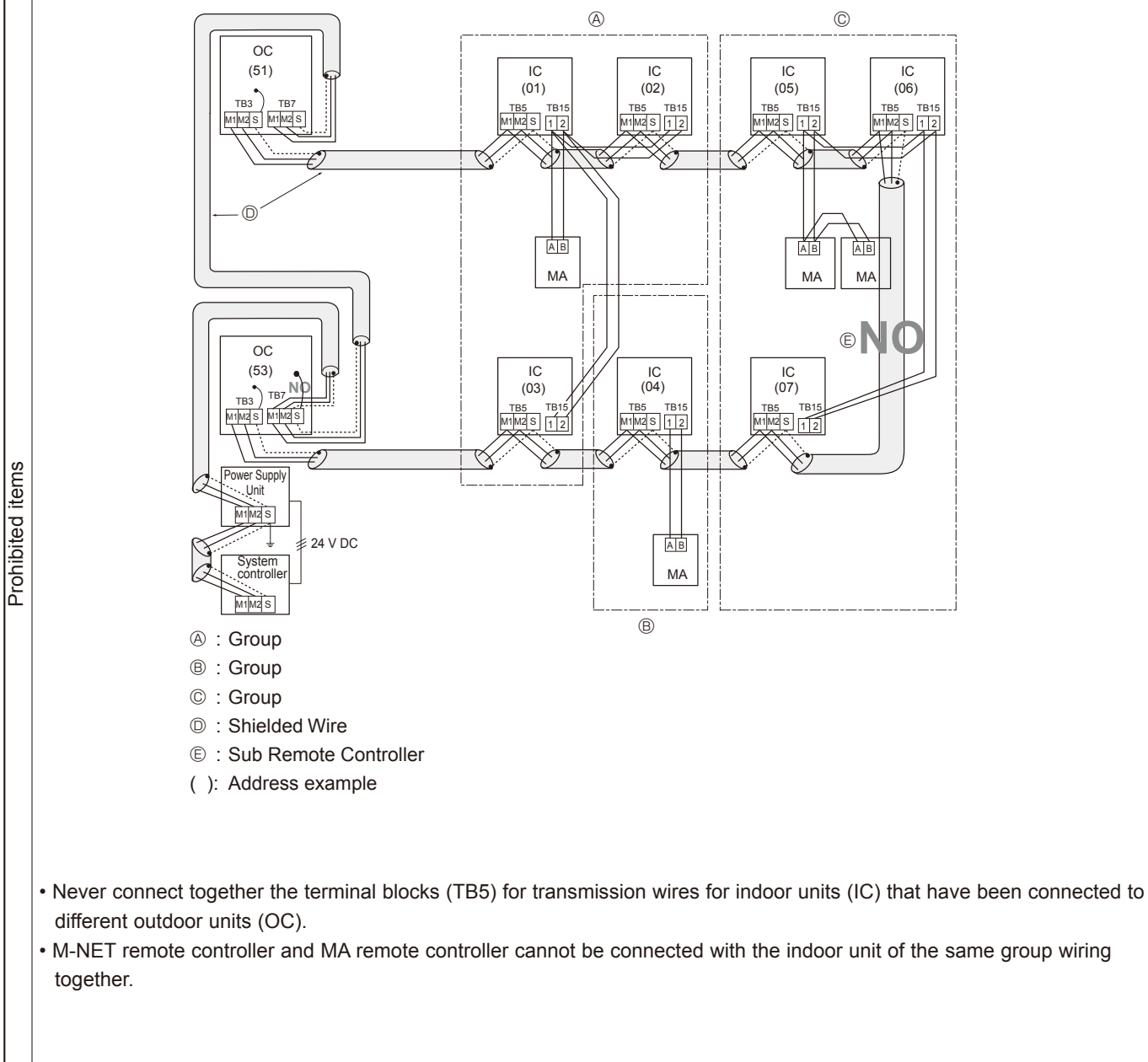

## 9-1. CHECK POINTS FOR TEST RUN

### 9-1-1. Procedures before test run

- (1) Before a test run, make sure that the following work is completed.
  - Installation related :  
Make sure that the panel of cassette type and electrical wiring are done.  
Otherwise electrical functions like auto vane will not operate normally.
  - Piping related :  
Perform leakage test of refrigerant and drain piping.  
Make sure that all joints are perfectly insulated.  
Check stop valves on both liquid and gas side for full open.
  - Electrical wiring related :  
Check ground wire, transmission cable, remote controller cable, and power supply cable for secure connection.  
Make sure that all switch settings of address or adjustments for special specification systems are correctly settled.
- (2) Safety check :  
With the insulation tester of 500V, inspect the insulation resistance.  
Do not touch the transmission cable and remote controller cable with the tester.  
The resistance should be over 1.0 MΩ. Do not proceed inspection if the resistance is under 1.0 MΩ.  
Inspect between the outdoor unit power supply terminal block and ground first, metallic parts like refrigerant pipes or the electrical box next, then inspect all electrical wiring of outdoor unit, indoor unit, and all linked equipment .
- (3) Before operation :
  - a) Turn the power supply switch of the outdoor unit to on for compressor protection. For a test run, wait at least 12 hours from this point.
  - b) Register control systems into remote controller(s). Never touch the on/off switch of the remote controller(s). Refer to “9-1-2. Special Function Operation and Settings (for M-NET Remote Controller)” as for settings. In MA remote controller(s), this registration is unnecessary.
- (4) More than 12 hours later from power supply to the outdoor unit, turn all power switch to on for the test run. Perform test run according to the “Operation procedure” table of the bottom of this page. While test running, make test run reports .

#### 9-1-1-1. Test run for M-NET Remote controller

When you deliver the unit after the test run, instruct the end user for proper usage of the system using owners' manual and the test run report you made to certificate normal operation. If abnormalities are detected during test run, refer to “9-1-3 Countermeasures for Error During Test Run”. As for DIP switch setting of outdoor unit, refer to “9-5. INTERNAL SWITCH FUNCTION TABLE”.

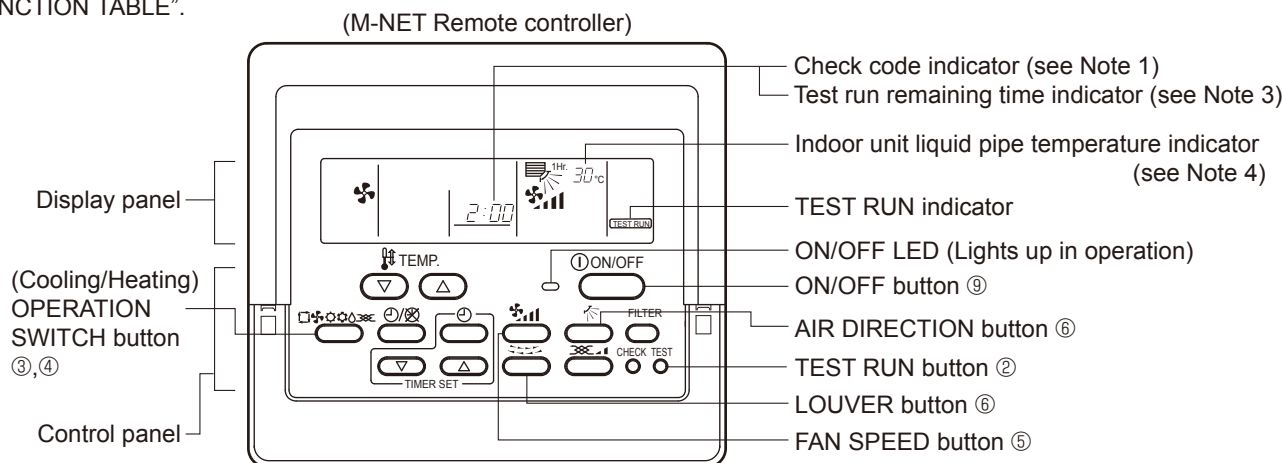

#### Operation procedure

①	Turn on the main power supply of all units at least 12 hours before test run. "HO" appears on display panel for 3 minutes.
②	12 hours later, press TEST RUN button twice to perform test run. "TEST RUN " appears on display panel.
③	Press OPERATION SWITCH button to make sure that air blows out.
④	Select Cooling (or Heating) by OPERATION SWITCH button to make sure that cool (or warm) air blows out.
⑤	Press Fan speed button to make sure that fan speed is changed by the button.
⑥	Press AIR DIRECTION button or LOUVER button to make sure that air direction is adjustable (horizontal, downward, upward, and each angle).
⑦	Check outdoor fans for normal operation.
⑧	Check interlocked devices (like ventilator) for normal operation, if any. This is the end of test run operation.
⑨	Press ON/OFF button to stop and cancel test run.

#### Notes:

1. If check code appears on remote controller or remote controller malfunctions, refer to “9-1-3 Countermeasures for Error During Run”.
2. During test run operation, 2-hour off timer activates automatically and remaining time is on remote controller and test run stops 2 hours later.
3. During test run, the indoor liquid pipe temperature is displayed on remote controller instead of room temperature.
4. Depending on a model, “This function is not available” appears when air direction button is pressed. However, this is not malfunction.

## 9-1-1-2. Test run for wired remote controller <PAR-31MAA>

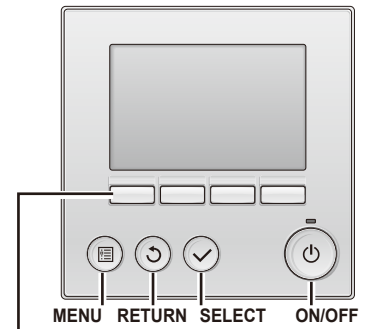

① Select "Service" from the Main menu, and press the button.



Select "Test run" with the **F1** or **F2** button, and press the button.

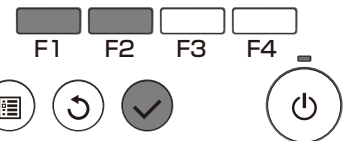
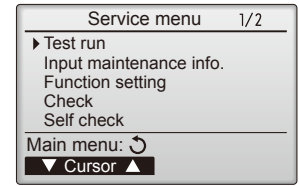

② Select "Test run" with the **F1** or **F2** button, and press the button.

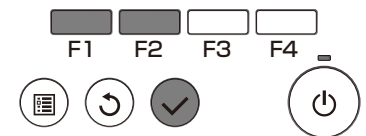
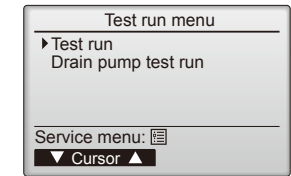

### Test run operation

Press the **F1** button to go through the operation modes in the order of "Cool and Heat".

**Cool mode:** Check the cold air blow off.

**Heat mode:** Check the heat blow off.



Press the button and open the Vane setting screen.

### Auto vane check\*

Check the auto vane with the **F1** **F2** buttons.

Check the operation of the outdoor unit fan, also.



Press the button to return to "Test run operation".



Press the button.

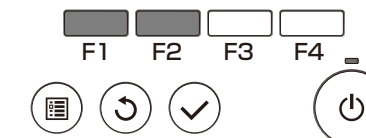
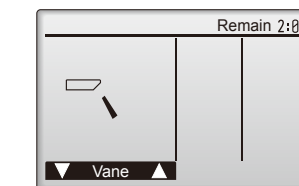
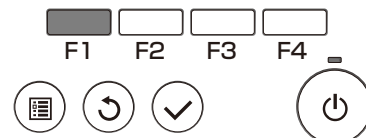
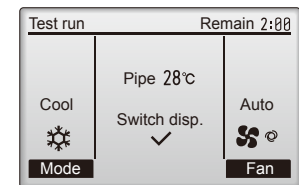

When the test run is completed, the "Test run menu" screen will appear. The test run will automatically stop after two hours.

\*The function is available only for the model with vanes.

## 9-1-2. Special Function Operation and Settings (for M-NET Remote Controller)

- It is necessary to perform “group settings” and “paired settings” at making group settings of different refrigerant systems (multiple outdoor unit).

(A) Group settings: Enter the indoor unit controlled by the remote controller, check the content of entries, and clear entries, etc.

(B) Paired settings: Used to set the linked operation of a Lossnay unit.

(1) Entering address: Follow the steps below to enter the addresses of the indoor unit using the remote controller.

### a) Group settings



- Turning off the remote controller: Press the ON/OFF button to stop operation (the indicator light will go off).
- Changing to indoor unit address display mode: If the FILTER and  buttons on the remote controller are pressed simultaneously and held for 2 seconds, the display shown in Figure 1 will appear.
- Changing address: Press the temperature adjustment  buttons to change the displayed address to the address to be entered.
- Entering the displayed address: Press the TEST RUN button to enter the indoor unit with the displayed address. The type of the unit will be displayed as shown in Figure 2 if entry is completed normally. If a selected indoor unit does not exist, an error signal will be displayed as shown in Figure 3. When this happens, check whether the indoor unit actually exists and perform entry again.
- Returning to the normal mode after completing entry: Press the FILTER and  buttons simultaneously and hold for 2 seconds to return to the normal mode.

Figure 1. (A) Group setting display

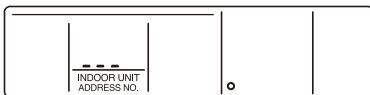

Figure 2. Normal completion of entry



Type of unit is displayed.

Figure 3. Entry error signal



Flashing “88” indicates entry error.



### b) Paired Settings

- Turn off the remote controller: Press the remote controller’s ON/OFF button to turn it off (the indicator light will go off).
- Put in indoor unit address display mode: Press the FILTER and  buttons on the remote controller simultaneously and hold for 2 seconds.

Note: The above steps are the same as when making group settings (A).

- Changing to the linked operation unit address display state: The display shown in Figure 4 will appear when the  button on the remote control is pressed.
- Displaying the address of the Lossnay unit and linked indoor unit: In this situation, the indoor unit number will be the lowest address of the group. The Lossnay unit will not operate if this setting is incorrect.

Notes:

- If the temperature adjustment  buttons are pressed, the address may be changed to the indoor unit that is to be linked.
- If the time setting  buttons are pressed, the address of the linked units may be changed to the address where it is desired to enter the Lossnay.

- Linking the Lossnay and the indoor unit: The display shown in Figure 5 will appear when the TEST RUN button is pressed. The indoor unit whose address is displayed and the Lossnay unit with a linked address will operate in a linked manner.

Notes:

- If it is desired to display the address of the Lossnay in the indoor unit address, display the indoor unit address in the linked unit address, and the above content will also be recorded.
- Apart from the indoor unit with the lowest address in the group, display and enter the addresses of the other indoor unit that are to be linked with the Lossnay unit.

- Returning to the normal mode after completing entry: Press the FILTER and  buttons on the remote controller simultaneously and hold for 2 seconds to return to the normal mode.

Figure 4. (B) Making paired settings



The addresses of indoor unit and linked units are displayed simultaneously.

Figure 5. Completing normal entry

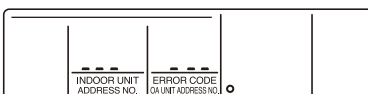
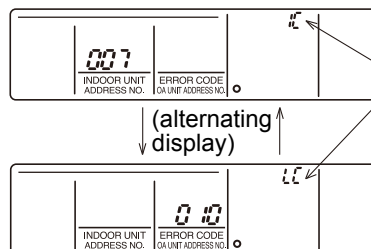



These alternating IC or LC displays will appear when entry is completed normally.







A flashing “88” will appear if there is a problem with the entry (indicating that the unit does not exist).

(2) Address check: Refer to section (1) regarding address entry.

**a) In making group settings:**

- Turn off the remote controller: Press the remote controller's ON/OFF button to stop operation (the indicator light will go off).
- Locate the indoor unit address display mode: Press the FILTER and  buttons on the remote controller simultaneously and hold for 2 seconds.
- Display indoor unit address: The entered indoor units address and type will be displayed each time the button is pressed.
  - \* When 1 entry is made, only 1 address will be displayed no matter how many times the  button is pressed.
- Returning to the normal mode after completing check: Simultaneously press the FILTER and  buttons on the remote controller and hold for 2 seconds to return to the normal mode.

**b) In making paired settings:**

- Turn off the remote controller: Press the remote controller's ON/OFF button to stop operation (the indicator light will go off).
- Put in indoor unit address display mode: Press the FILTER and  buttons on the remote controller simultaneously and hold for 2 seconds.
- Changing to the linked operation unit address display state: Press the  button on the remote control.
- Displaying the address of the indoor unit to be checked: Change the address to that of the indoor unit to be checked by pressing the temperature adjustment buttons .
- Displaying the address of the linked Lossnay unit: Press the  button to display the addresses of the linked Lossnay and indoor unit in alternation.
- Displaying the addresses of other entered units: The addresses of the other entered units will be displayed in alternating fashion after resting the  button again.
- Returning to the normal mode after completing the check: Simultaneously press the FILTER and  buttons on the remote controller and hold for 2 seconds to return to the normal mode.

(3) Clearing an address: Refer to section (1) regarding the address entry and section (2) regarding checking addresses.

**a) In making group settings:**

- Turn off the remote controller: The procedure is the same as described in **a)** under (2) Address check.
- Put in the indoor unit address display mode: The procedure is the same as described in **a)** under (2) Address check.
- Displaying the indoor unit address to be cleared: The procedure is the same as described in **a)** under (2) Address check.
- Clearing indoor unit address : Pressing the  button on the remote controller twice will clear the address entry of the displayed indoor unit, resulting in the display shown in Figure 6.

The display shown in Figure 7 will appear if an abnormality occurs and the entry is not cleared. Please repeat the clearing procedure.

- Returning to the normal mode after clearing an address: The procedure is the same as described in **a)** under (2) Address check.

Figure 6. Display after address has been cleared normally

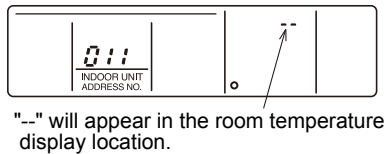
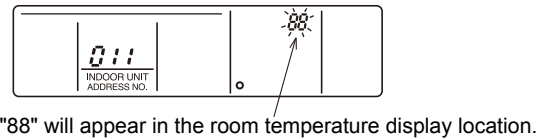

Figure 7. Display when an abnormality has occurred during clearing



**b) In making paired settings:**

- Turn off the remote controller: The procedure is the same as described in **b)** under (2) Address check.
- Put into the indoor unit address display mode: The procedure is the same as described in **b)** under (2) Address check.
- Put into the linked unit address display mode: The procedure is the same as described in **b)** under (2) Address check.
- Display the address of the Lossnay unit or the indoor unit to be cleared.
- Deleting the address of a linked indoor unit: Pressing the  button on the remote controller twice will clear the address entry of the displayed indoor unit, resulting in the display shown in Figure 8.
- Returning to the normal mode after clearing an address: The procedure is the same as described in **b)** under (2) Address check.

Figure 8. Display after address has been cleared normally



### 9-1-3. Countermeasures for Error During Test Run

- If a problem occurs during test run, a code number will appear on the remote controller (or LED on the outdoor unit), and the air conditioning system will automatically cease operating.

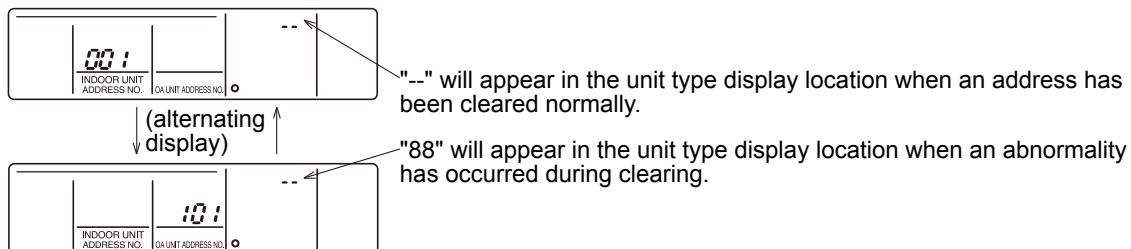
Determine the nature of the abnormality and apply corrective measures.

Check code	Trouble	Detected Unit			Remarks
		Indoor	Outdoor	Remote Controller	
0403	Serial communication error		○		Outdoor unit Multi controller board ~ Power circuit board communication trouble
1102	Compressor temperature		○		Check delay code 1202
1300	Low pressure		○		
1302	High pressure		○		Check delay code 1402
1500	Superheat due to low discharge temperature		○		Check delay code 1600
1501	Refrigerant shortage		○		Check delay code 1601
2500	Water leakage	○			
2502	Drain over flow protection	○			
2503	Drain sensor abnormality	○			
4100	Compressor current interruption (locked compressor)		○		Check delay code 4350
4210	Compressor overcurrent interruption		○		
4220	Voltage shortage/overvoltage/PAM error/L1open phase/power synchronization signal error		○		Check delay code 4320
4230	Heat sink temperature		○		Check delay code 4330
4250	Power module		○		Check delay code 4350
4400	Rotational frequency of outdoor fan motor		○		Check delay code 4500
5101	Air inlet thermistor trouble (TH21) or Compressor temperature thermistor (TH4) open/short	○			Check delay code 1202
5102	Liquid pipe temperature thermistor trouble (TH22) Suction pipe temperature thermistor (TH6) open/short	○			Check delay code 1211
5103	Gas pipe temperature thermistor trouble (TH23)	○			
5105	Outdoor pipe temperature thermistor (TH3) open/short		○		Check delay code 1205
5106	Outdoor thermistor (TH7) open/short		○		Check delay code 1221
5110	Heat sink temperature thermistor (TH8) open/short		○		Check delay code 1214
5201	High pressure sensor (63HS)		○		Check delay code 1402
5300	Primary current		○		Check delay code 4310
5701	Contact failure of drain float switch	○			
6600	Duplex address error	○	○	○	Only M-NET Remote controller is detected.
6602	Transmission processor hardware error	○	○	○	Only M-NET Remote controller is detected.
6603	Transmission bus BUSY error	○	○	○	Only M-NET Remote controller is detected.
6606	Signal communication error with transmission processor	○	○	○	Only M-NET Remote controller is detected.
6607	No ACK error	○		○	Only M-NET Remote controller is detected. *
6608	No response frame error	○		○	Only M-NET Remote controller is detected. *
6831	MA communication receive error (no receive signal)	○		○	Only MA Remote controller is detected.
6832	MA communication send error	○		○	Only MA Remote controller is detected.
6833	MA communication send error	○		○	Only MA Remote controller is detected.
6834	MA communication receive error	○		○	Only MA Remote controller is detected.
7100	Total capacity error		○		
7101	Capacity code error	○	○		
7102	Connecting excessive number of units		○		
7105	Address setting error		○		

**Note:**  
**When the outdoor unit detects No ACK error/No response error, an object indoor unit is treated as a stop, and not assumed to be abnormal.**  
 \*Abnormality for PWFY series

#### Self-diagnosis function

The indoor and outdoor units can be diagnosed automatically using the self-diagnosis switch (SW1) and LED1, LED2 (LED indication) found on the multi-controller of the outdoor unit.  
 LED indication : Set all contacts of SW1 to OFF.

During normal operation

The LED indicates the drive state of the controller in the outdoor unit.

[Example]

When the compressor and SV1 are turned during cooling operation.

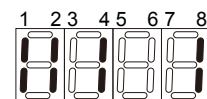

Bit	1	2	3	4	5	6	7	8
Indication	Compressor operated	52C	21S4	SV1	(SV2)	—	—	Always lit

## Serial communication error

Abnormal points and detection methods	Causes and check points
Abnormal if serial communication between the outdoor controller board and outdoor power circuit board is defective.	① Wire breakage or contact failure of connector CN2 or CN4 ② Malfunction of power circuit board communication circuit on outdoor controller board ③ Malfunction of communication circuit on outdoor power circuit board

●Diagnosis of defectives

Make sure to turn the power OFF before connecting/disconnecting any connectors, or replacing boards.

Diagnosis	Remedy
<p>Check the connection of the communication line (CN2 and CN4) between the outdoor controller board and power circuit board.</p> <p>Are they connected normally?</p> <p>No</p> <p>Yes</p>	<p>Connect the CN2 and CN4 properly. Replace them in case of a breakage.</p> <p>The communication circuit of either the outdoor controller board or power circuit board is defective. If unable to identify the defective circuit;</p> <p>① Replace the outdoor controller board if it does not recover. ② Replace the outdoor power circuit board</p>

## Compressor temperature trouble

Abnormal points and detection methods	Causes and check points
<p>(1) Abnormal if TH4 falls into following temperature conditions;</p> <ul style="list-style-type: none"> <li>●exceeds 230°F [110°C] continuously for 5 minutes</li> <li>●exceeds 257°F [125°C]</li> </ul> <p>(2) Abnormal if a pressure detected by the high-pressure sensor and converted to saturation temperature exceeds 104°F [40°C] during defrosting, and TH4 exceeds 230°F [110°C].</p> <p>TH4: Thermistor &lt;Discharge/compressor&gt; LEV: Electronic expansion valve</p>	<ul style="list-style-type: none"> <li>① Malfunction of stop valve</li> <li>② Over-heated compressor operation caused by shortage of refrigerant</li> <li>③ Defective thermistor</li> <li>④ Defective outdoor controller board</li> <li>⑤ LEV performance failure</li> <li>⑥ Defective indoor controller board</li> <li>⑦ Clogged refrigerant system caused by foreign object</li> <li>⑧ Refrigerant shortage while in heating operation (Refrigerant liquid accumulation in compressor while indoor unit is OFF/thermo-OFF.)</li> </ul>

## ●Diagnosis of defectives

Make sure to turn the power OFF before connecting/disconnecting any connectors, or replacing boards.

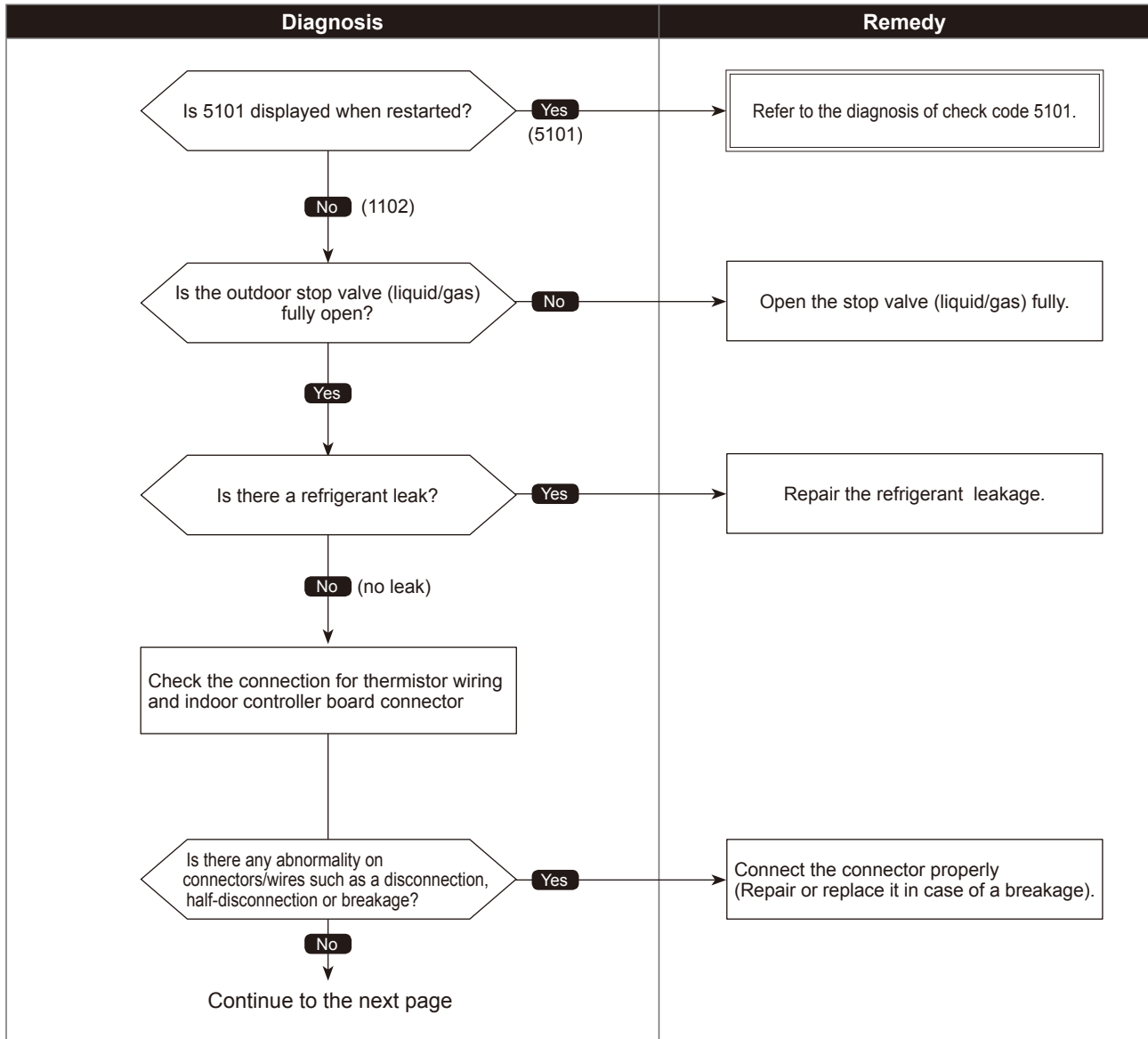

# Compressor temperature trouble

•Diagnosis of defectives

Make sure to turn the power OFF before connecting/disconnecting any connectors, or replacing boards.

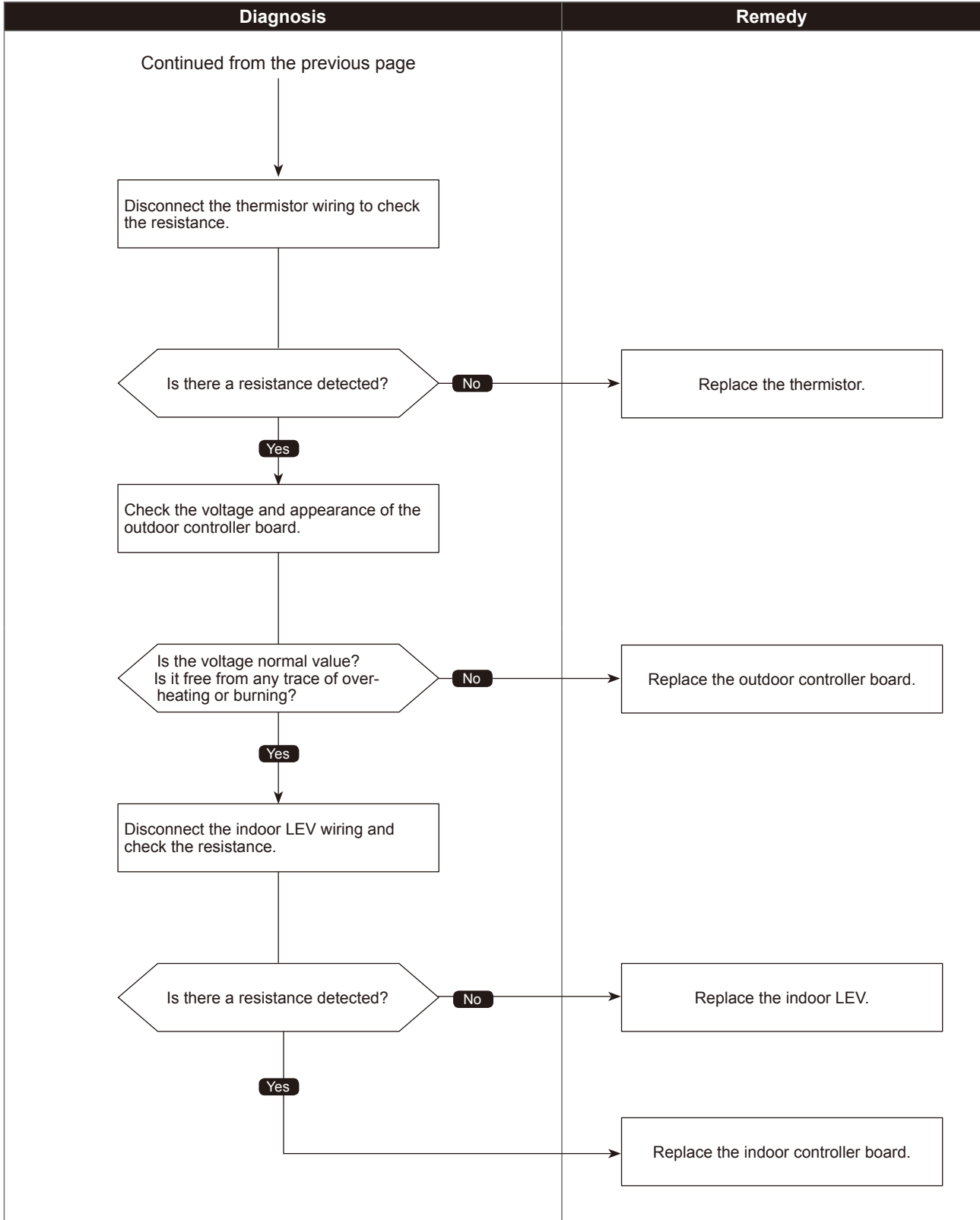

# Low pressure trouble

Abnormal points and detection methods	Causes and check points
<p>&lt;63L equipped model&gt;                      (1) Low pressure (63L is in operation)                      Abnormal if 63L operates (under -4 PSIG) during compressor operation.</p> <p>63L : Low pressure switch                      LEV : Electronic expansion valve                      SV1 : Solenoid valve                      TH7 : Thermistor &lt;Outdoor&gt;</p>	<ul style="list-style-type: none"> <li>① Defective operation of stop valve (not fully open)</li> <li>② Clogged or broken pipe</li> <li>③ Malfunction or locked outdoor fan motor</li> <li>④ Short-cycle of outdoor unit</li> <li>⑤ Dirt of outdoor heat exchanger</li> <li>⑥ Remote controller transmitting error caused by noise interference</li> <li>⑦ Contact failure of outdoor controller board connector</li> <li>⑧ Defective outdoor controller board</li> <li>⑨ Short-cycle of indoor unit</li> <li>⑩ Decreased airflow, clogged filter, or dirt on indoor unit.</li> <li>⑪ Malfunction or locked indoor fan motor</li> <li>⑫ Decreased airflow caused by defective inspection of outdoor temperature thermistor (It detects lower temperature than actual temperature.)</li> <li>⑬ Indoor LEV performance failure</li> <li>⑭ Malfunction of fan driving circuit</li> <li>⑮ SV1 performance failure</li> <li>⑯ Defective low-pressure sensor</li> <li>⑰ Malfunction of low-pressure sensor input circuit on outdoor controller board</li> </ul>

●Diagnosis of defectives

Make sure to turn the power OFF before connecting/disconnecting any connectors, or replacing boards.

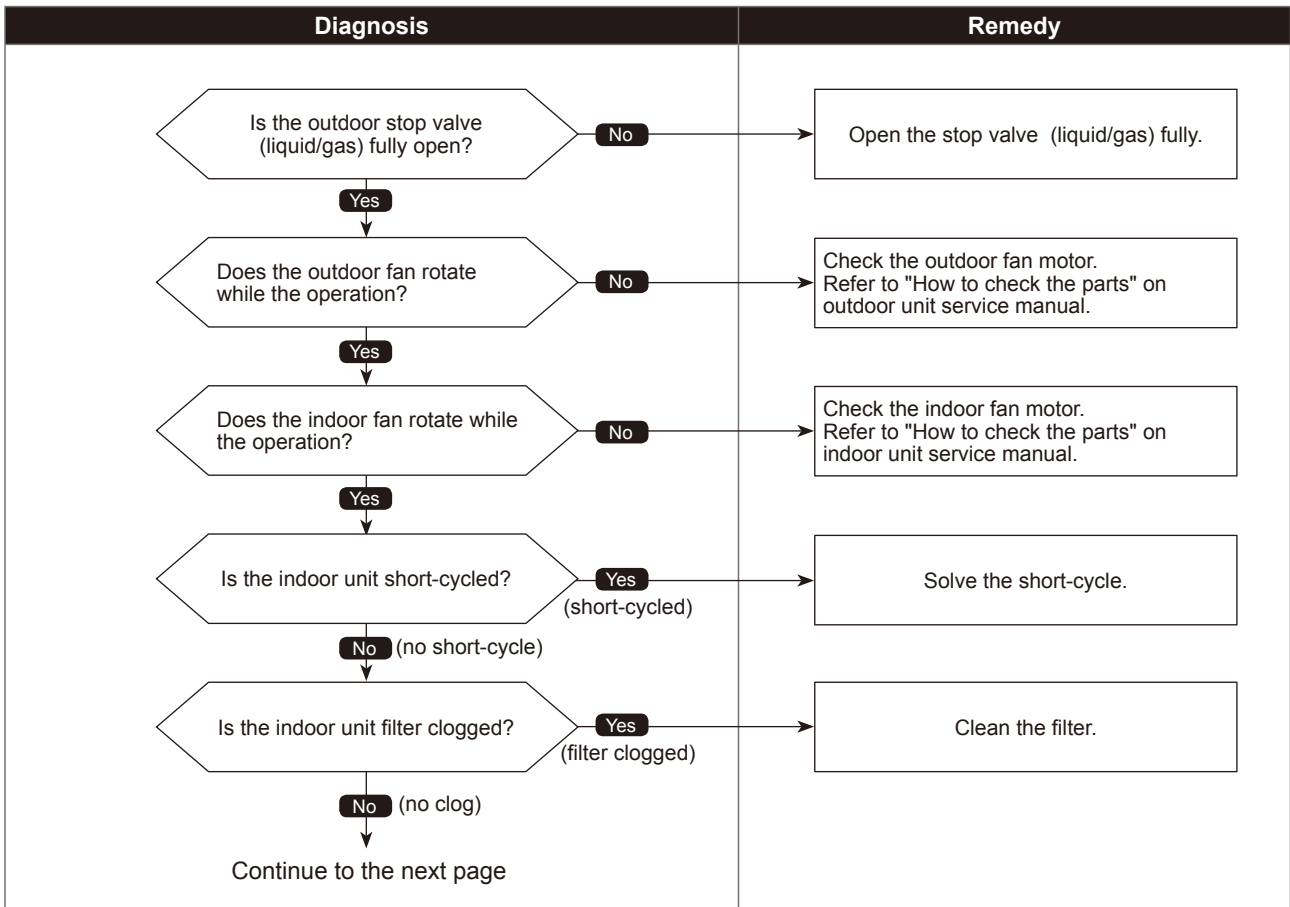

●Diagnosis of defectives

Make sure to turn the power OFF before connecting/disconnecting any connectors, or replacing boards.

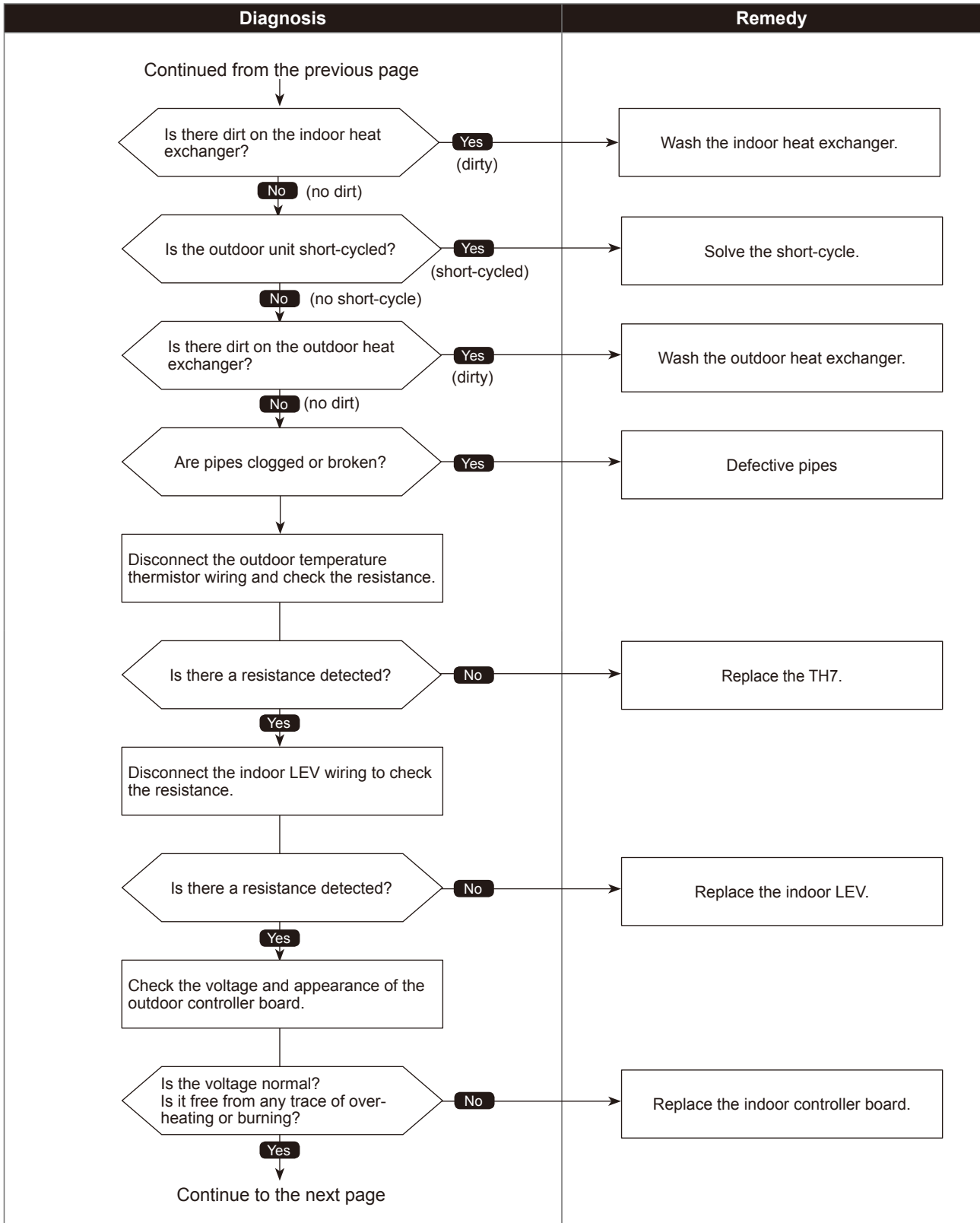

●Diagnosis of defectives

Make sure to turn the power OFF before connecting/disconnecting any connectors, or replacing boards.

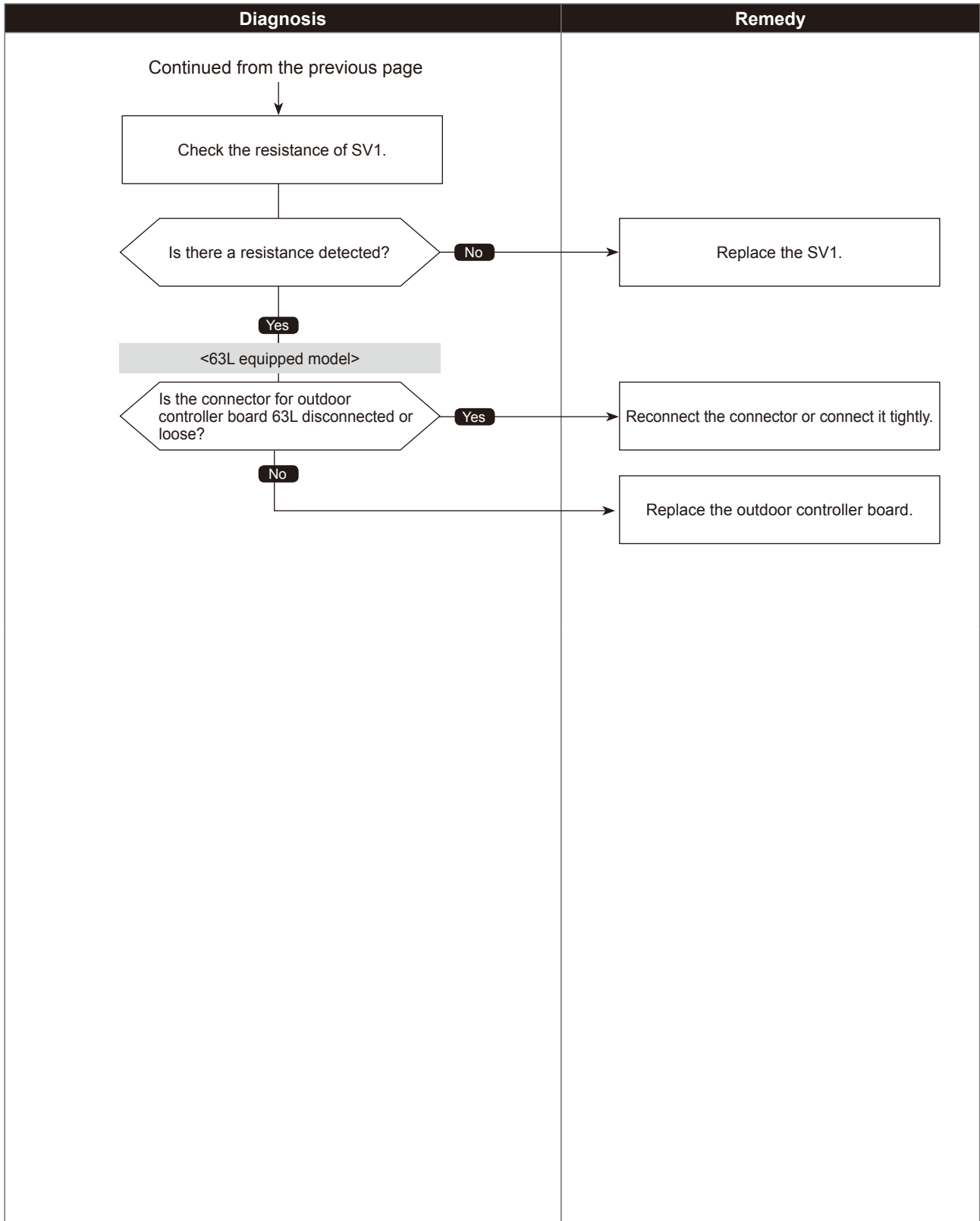

# High pressure trouble

Abnormal points and detection methods	Causes and check points
<p>&lt;63H equipped model (63HS non-equipped)&gt;                      (1) High pressure abnormality (63H operation)                      Abnormal if 63H operates(*) during compressor operation. (* 602 PSIG)</p> <p>&lt;63HS equipped model (63H non-equipped)&gt;                      (2) High pressure abnormality (63HS detected)                      Abnormal if a pressure detected by 63HS exceeds 602 PSIG during compressor operation.</p> <p>63H : High-pressure switch                      63HS: High-pressure sensor                      LEV : Electronic expansion valve                      SV1 : Solenoid valve                      TH7 : Thermistor &lt;Outdoor&gt;</p>	<ul style="list-style-type: none"> <li>① Defective operation of stop valve (not fully open)</li> <li>② Clogged or broken pipe</li> <li>③ Malfunction or locked outdoor fan motor</li> <li>④ Short-cycle of outdoor unit</li> <li>⑤ Dirt of outdoor heat exchanger</li> <li>⑥ Remote controller transmitting error caused by noise interference</li> <li>⑦ Contact failure of the outdoor controller board connector</li> <li>⑧ Defective outdoor controller board</li> <li>⑨ Short-cycle of indoor unit</li> <li>⑩ Decreased airflow, clogged filter, or dirt on indoor unit.</li> <li>⑪ Malfunction or locked indoor fan motor</li> <li>⑫ Decreased airflow caused by defective inspection of outdoor temperature thermistor (It detects lower temperature than actual temperature.)</li> <li>⑬ Indoor LEV performance failure</li> <li>⑭ Malfunction of fan driving circuit</li> <li>⑮ SV1 performance failure</li> <li>⑯ Defective high-pressure sensor</li> <li>⑰ Defective high-pressure sensor input circuit on outdoor controller board</li> </ul>

●Diagnosis of defectives

Make sure to turn the power OFF before connecting/disconnecting any connectors, or replacing boards.

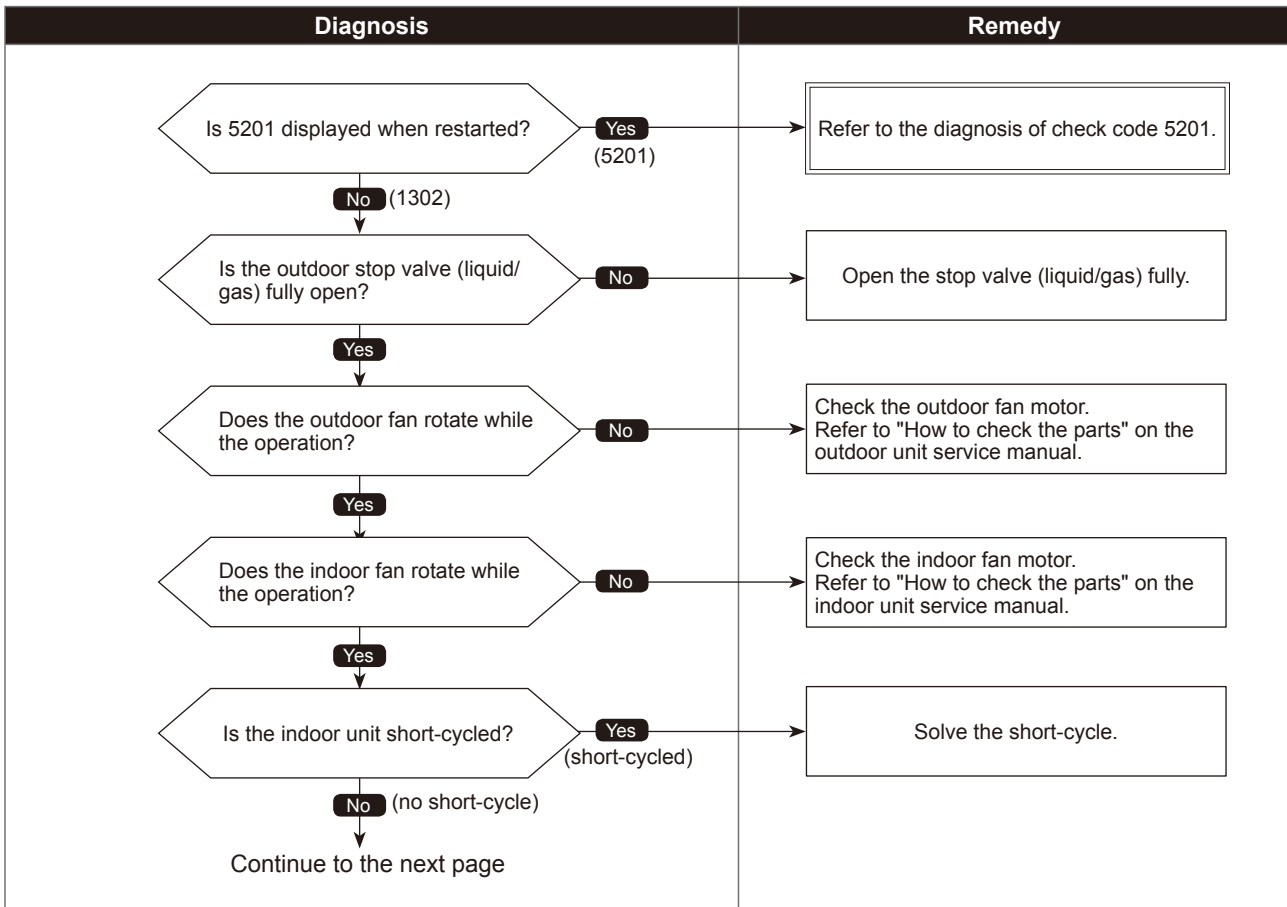

# High pressure trouble

●Diagnosis of defectives

Make sure to turn the power OFF before connecting/disconnecting any connectors, or replacing boards.

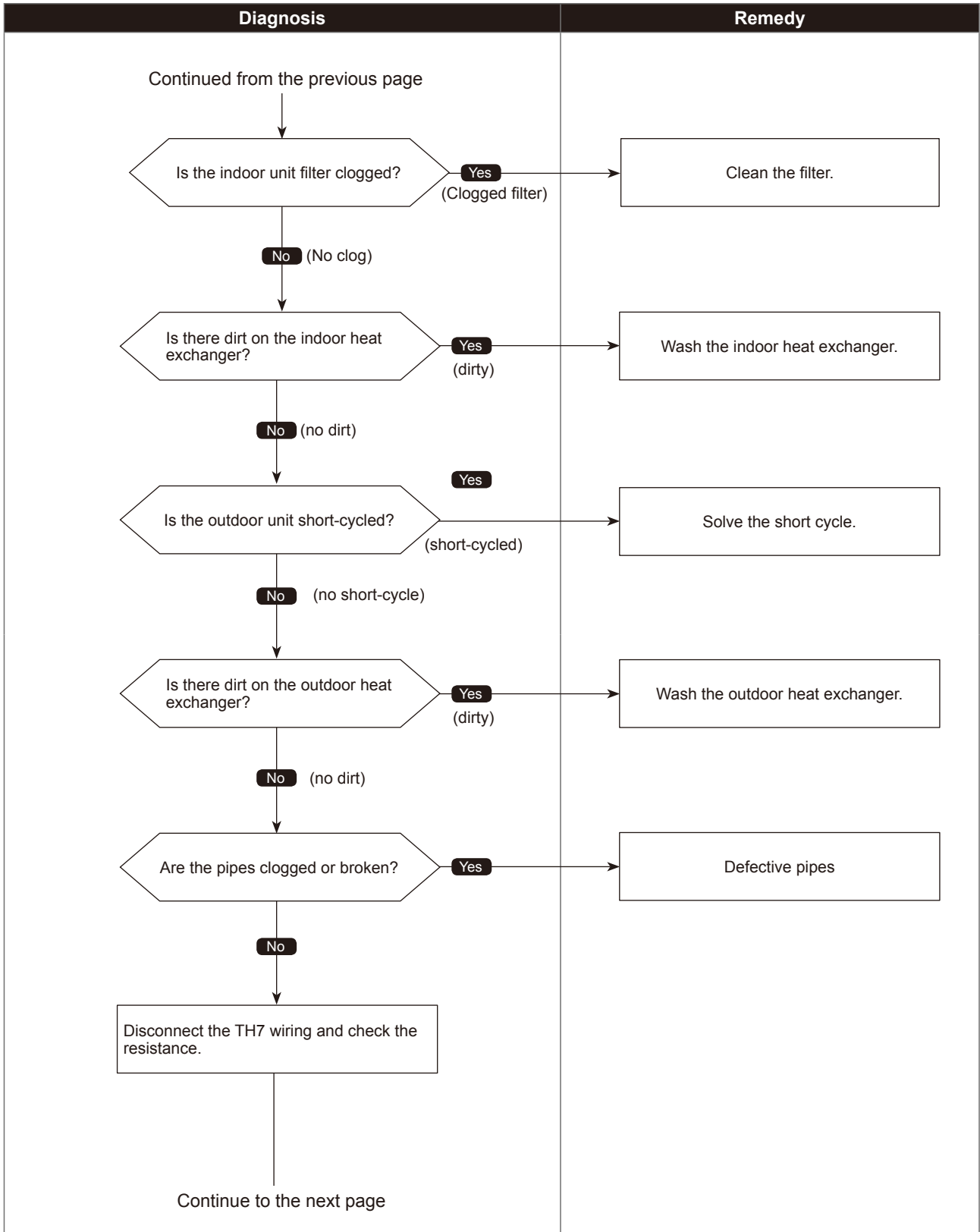

•Diagnosis of defectives

Make sure to turn the power OFF before connecting/disconnecting any connectors, or replacing boards.

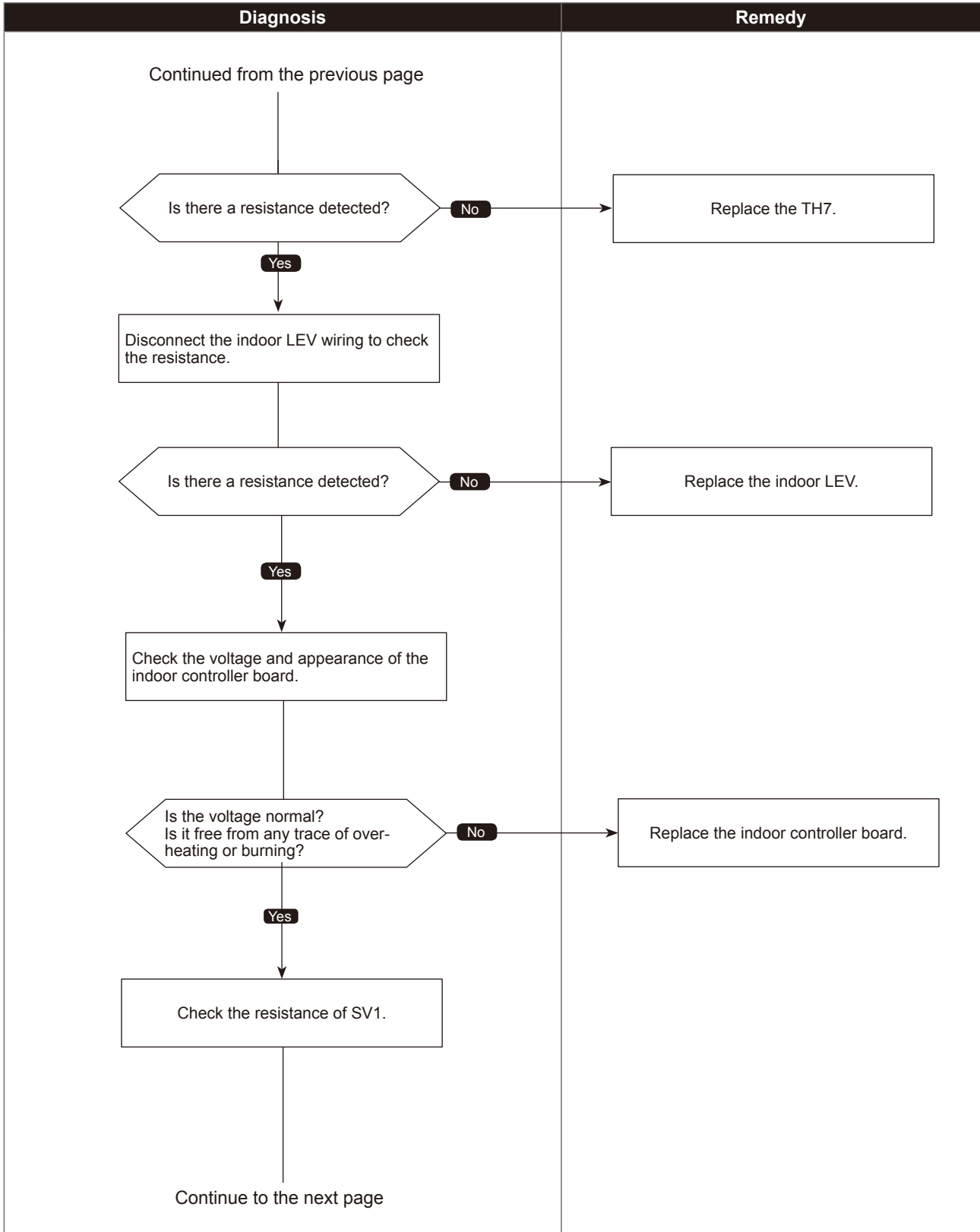

●Diagnosis of defectives

Make sure to turn the power OFF before connecting/disconnecting any connectors, or replacing boards.

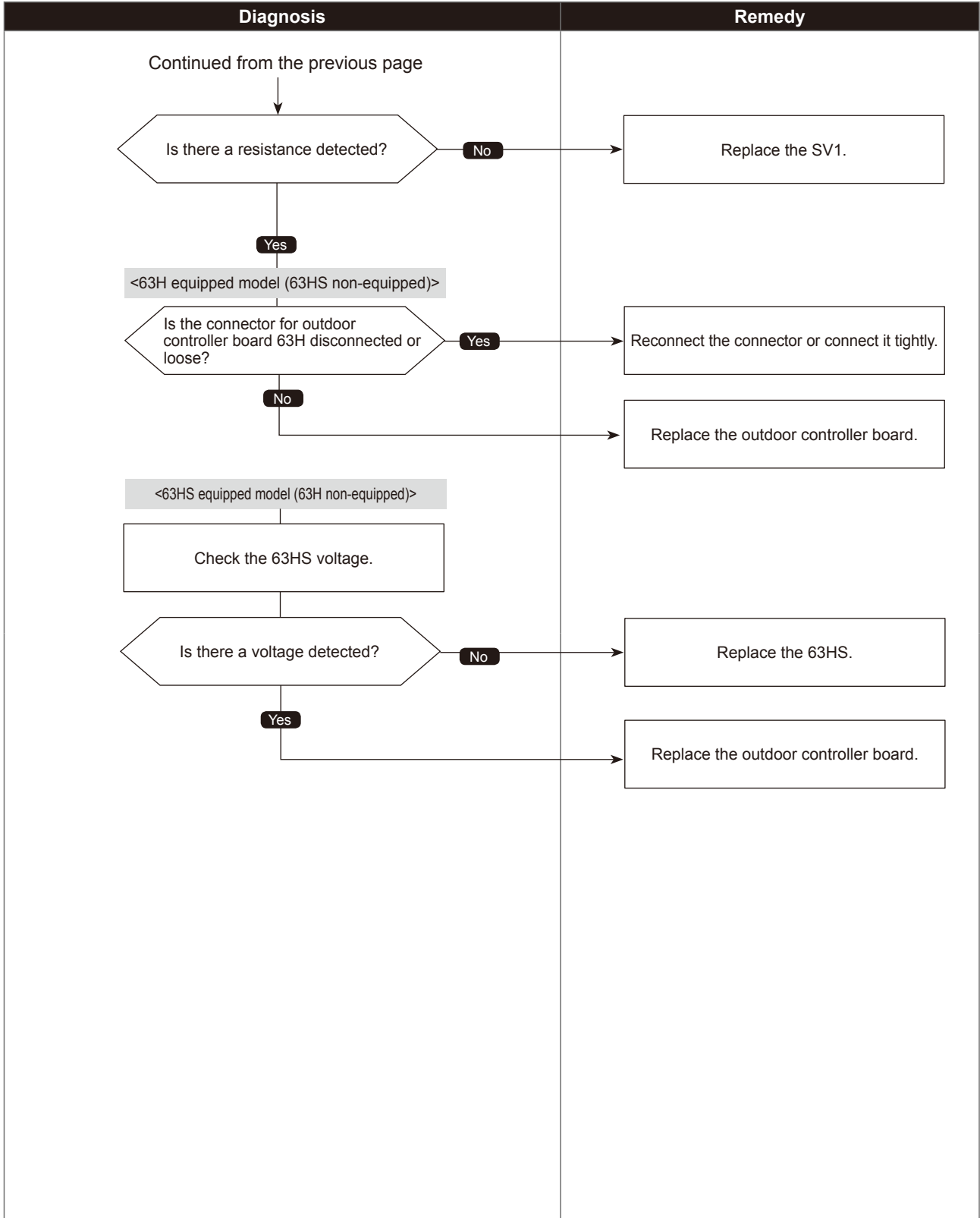

Abnormal points and detection methods	Causes and check points
<p>Abnormal if the discharge superheat is continuously detected less than or equal to 5°F [-15°C]* for 5 minutes even though the indoor LEV has minimum open pulse after the compressor starts operating for 10 minutes.</p> <p>LEV : Electronic expansion valve            TH4 : Thermistor &lt;Discharge/compressor&gt;            63HS: High-pressure sensor</p> <p>*At this temperature, conditions for the abnormality detection will not be satisfied if no abnormality is detected on either TH4 or 63HS.</p>	<p>① Disconnection or loose connection of TH4            ② Defective holder of TH4            ③ Disconnection of LEV coil            ④ Disconnection of LEV connector            ⑤ LEV performance failure</p>

●Diagnosis of defectives

Make sure to turn the power OFF before connecting/disconnecting any connectors, or replacing boards.

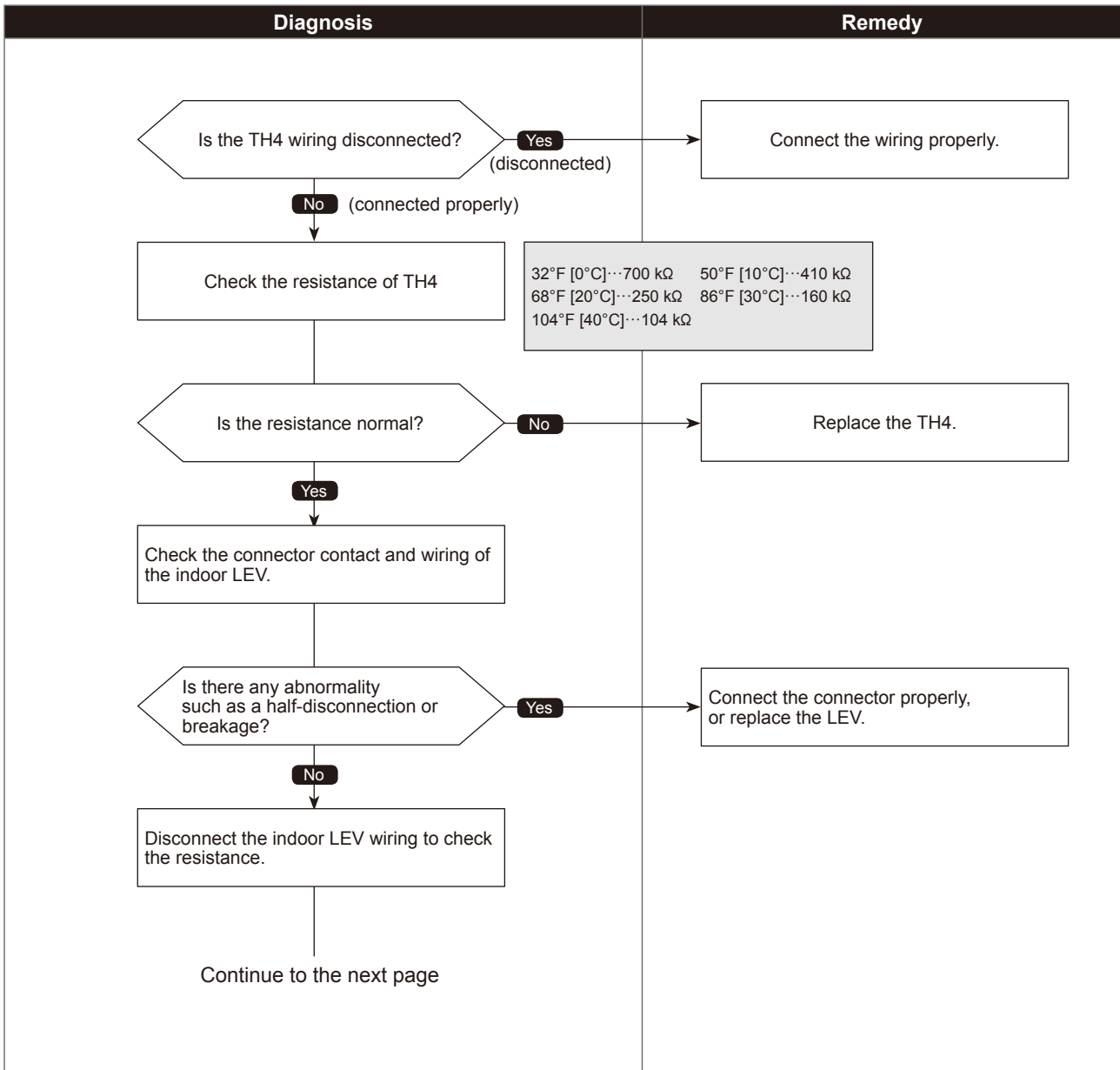

## ●Diagnosis of defectives

Make sure to turn the power OFF before connecting/disconnecting any connectors, or replacing boards.

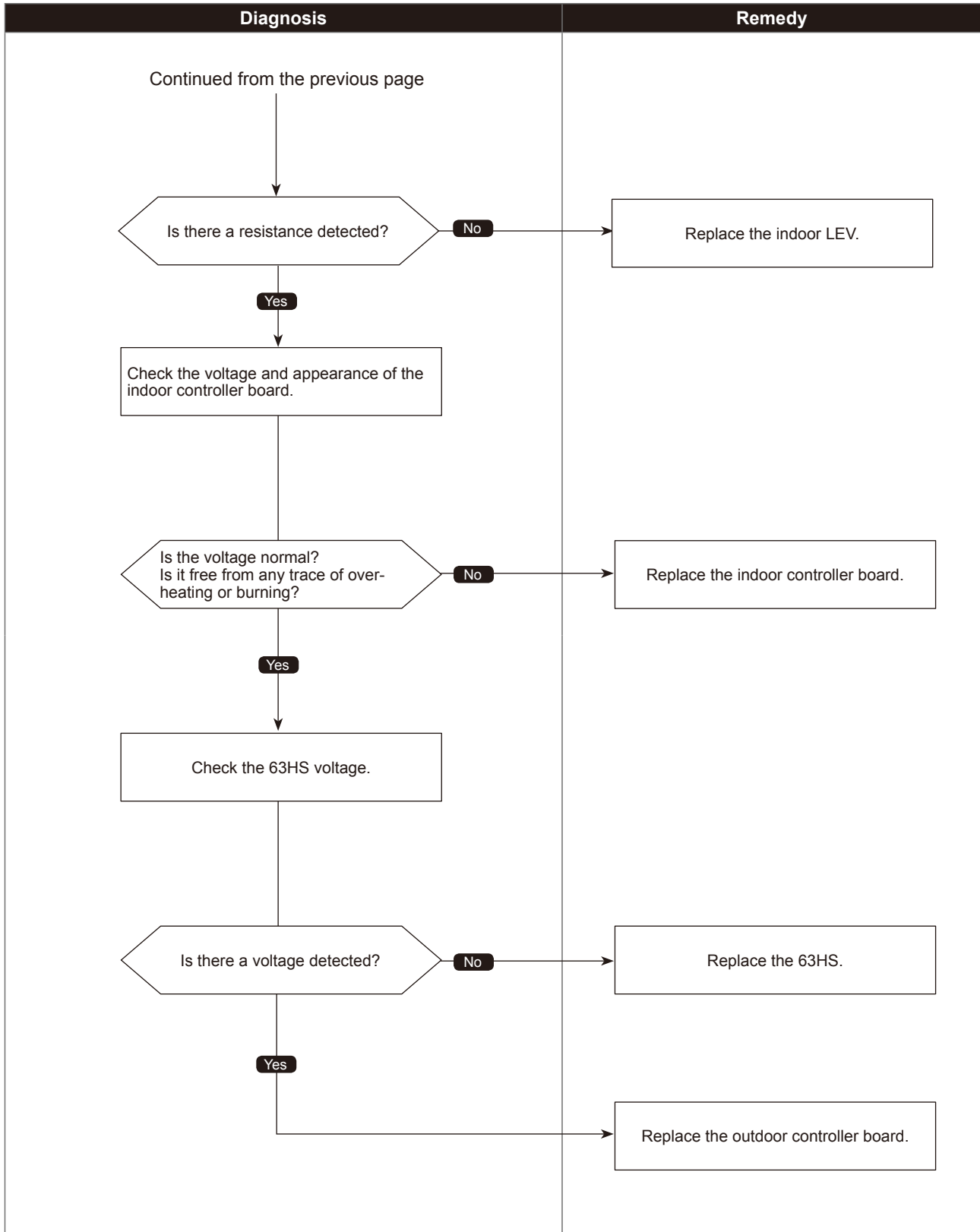

# Refrigerant shortage trouble

Abnormal points and detection methods	Causes and check points
<p>(1) Abnormal when all of the following conditions are satisfied:</p> <ol style="list-style-type: none"> <li>1.The compressor is operating in HEAT mode</li> <li>2.Discharge super heat is 176°F [80°C] or more.</li> <li>3.Difference between TH7 and the TH3 applies to the formula of (TH7-TH3 &lt; 41°F [5°C])</li> <li>4.The 63HS detects below 296 PSIG.</li> </ol> <p>(2) Abnormal when all of the following conditions are satisfied:</p> <ol style="list-style-type: none"> <li>1.The compressor is in operation.</li> <li>2.When cooling, discharge superheat is 176°F [80°C] or more. When heating, discharge superheat is 194°F [90°C] or more. The High-pressure sensor detects below 336 PSIG.</li> </ol>	<ol style="list-style-type: none"> <li>① Defective operation of stop valve (not fully open)</li> <li>② Defective thermistor</li> <li>③ Defective outdoor controller board</li> <li>④ Indoor LEV performance failure</li> <li>⑤ Gas leakage or shortage</li> <li>⑥ Defective 63HS</li> </ol> <p>TH3 : Thermistor &lt;Outdoor pipe&gt; TH7 : Thermistor &lt;Outdoor&gt; LEV : Electronic expansion valve 63HS: High-pressure sensor</p>

●Diagnosis of defectives

Make sure to turn the power OFF before connecting/disconnecting any connectors, or replacing boards.

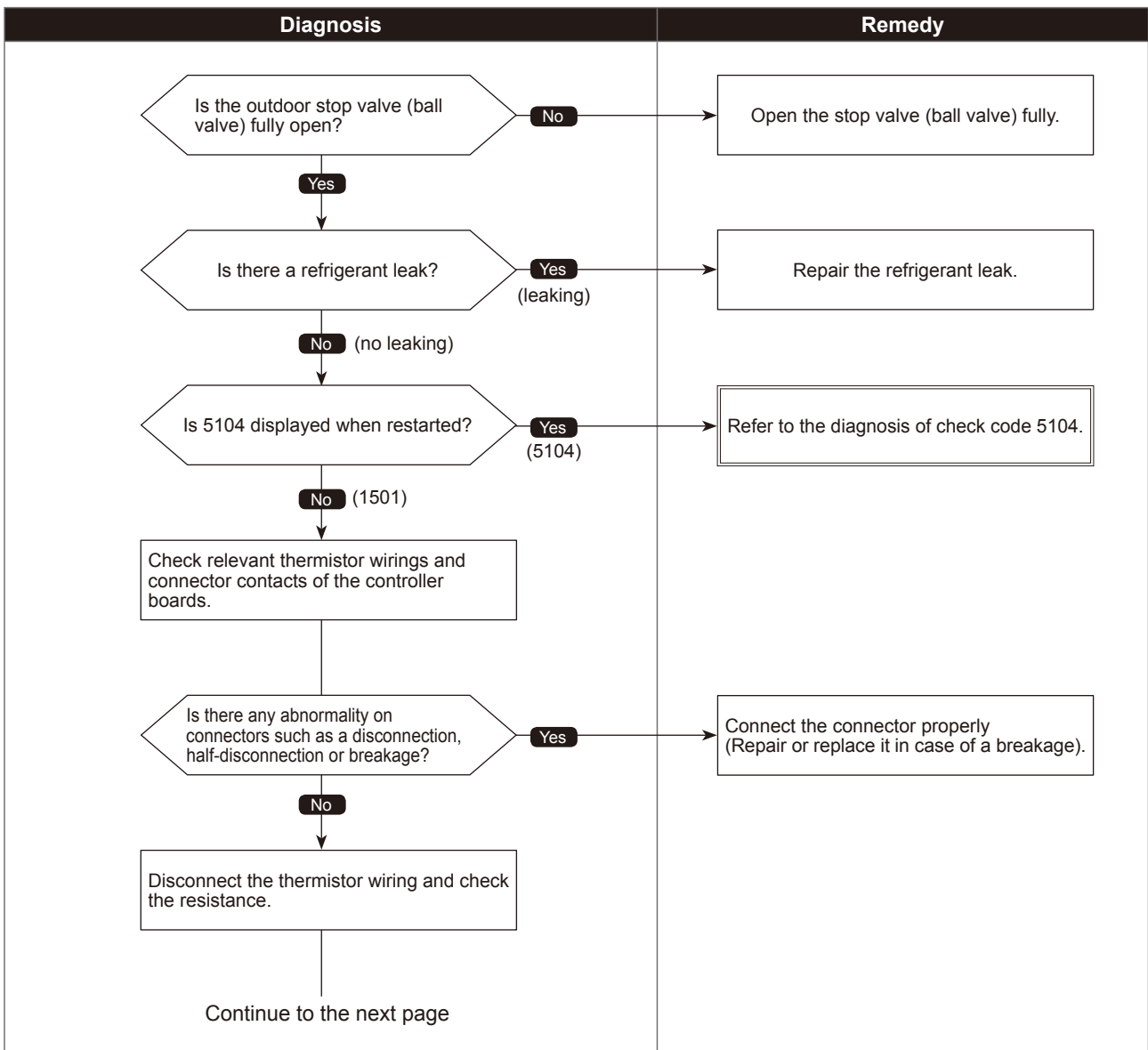

## Refrigerant shortage trouble

## ●Diagnosis of defectives

Make sure to turn the power OFF before connecting/disconnecting any connectors, or replacing boards.

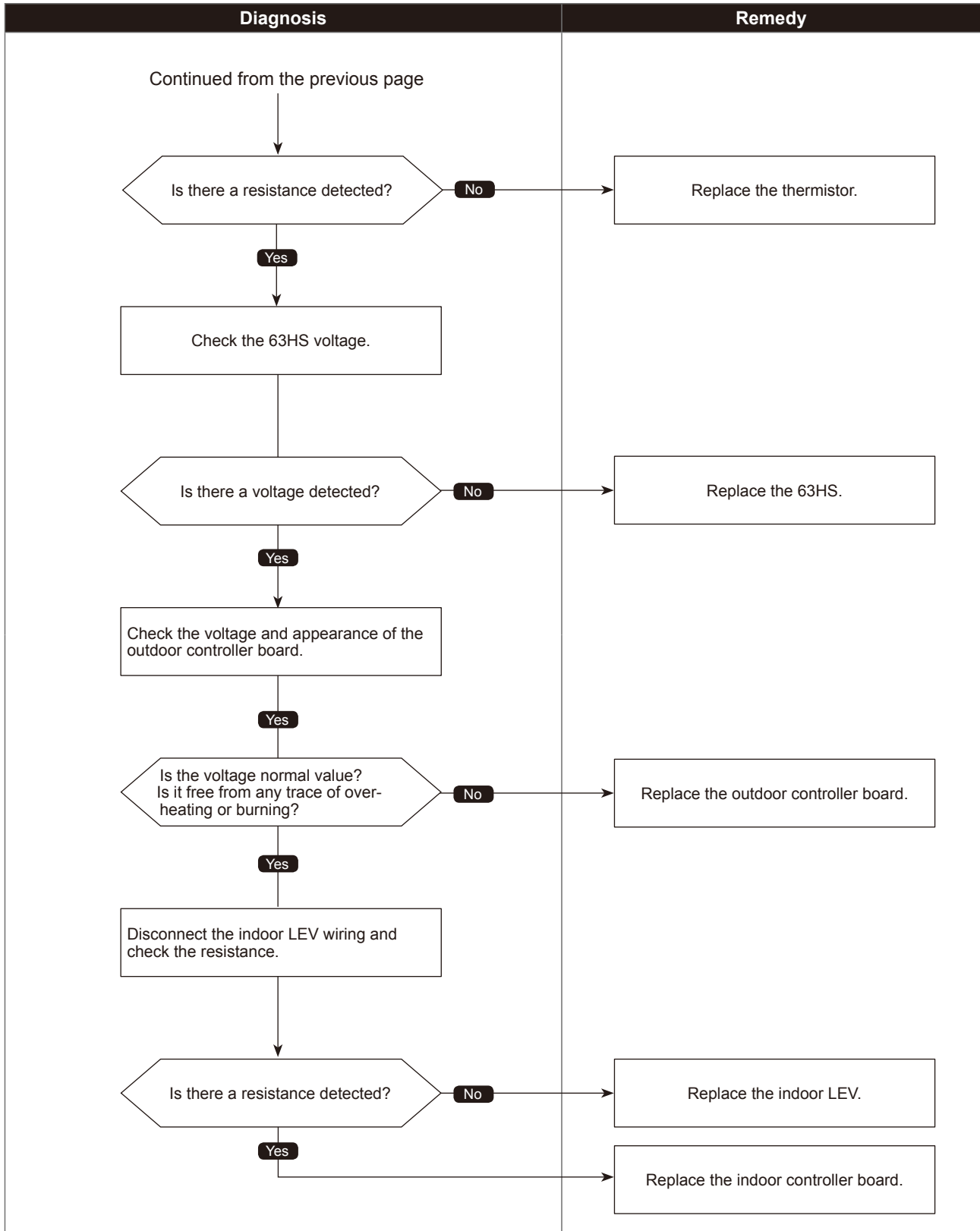

Abnormal points and detection methods	Causes and check points
<p>Abnormal if drain sensor or float switch detects to be in the water during cooling or dry operation.</p> <p><b>To release this abnormality, reset the power (turn OFF and ON).</b></p> <p>TH21: Indoor intake temperature thermistor                      TH22: Indoor liquid pipe temperature thermistor                      TH23: Indoor gas pipe temperature thermistor</p>	<ul style="list-style-type: none"> <li>① Reverse connection of extended piping (when connecting multiple units)</li> <li>② Reverse connection of indoor/outdoor connector</li> <li>③ Defective thermistor of TH21 or TH22/23</li> <li>④ Defective drain sensor or float switch</li> <li>⑤ Defective drain pump                             <ul style="list-style-type: none"> <li>· Clogged drain pump</li> <li>· Clogged drain pipe</li> </ul> </li> <li>⑥ Poor drainage</li> </ul>

●Diagnosis of defectives

Make sure to turn the power OFF before connecting/disconnecting any connectors, or replacing boards.

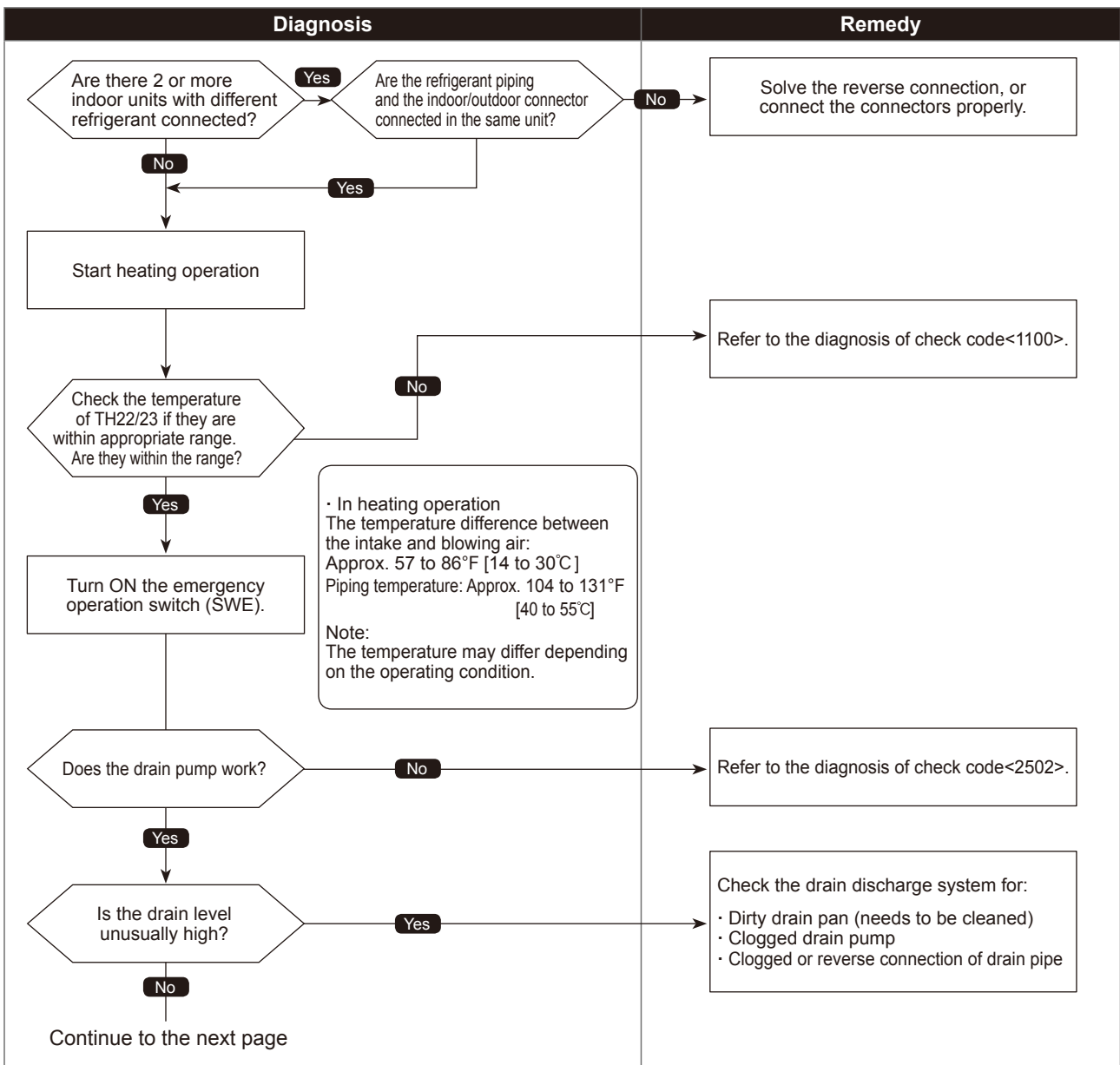

●Diagnosis of defectives

Make sure to turn the power OFF before connecting/disconnecting any connectors, or replacing boards

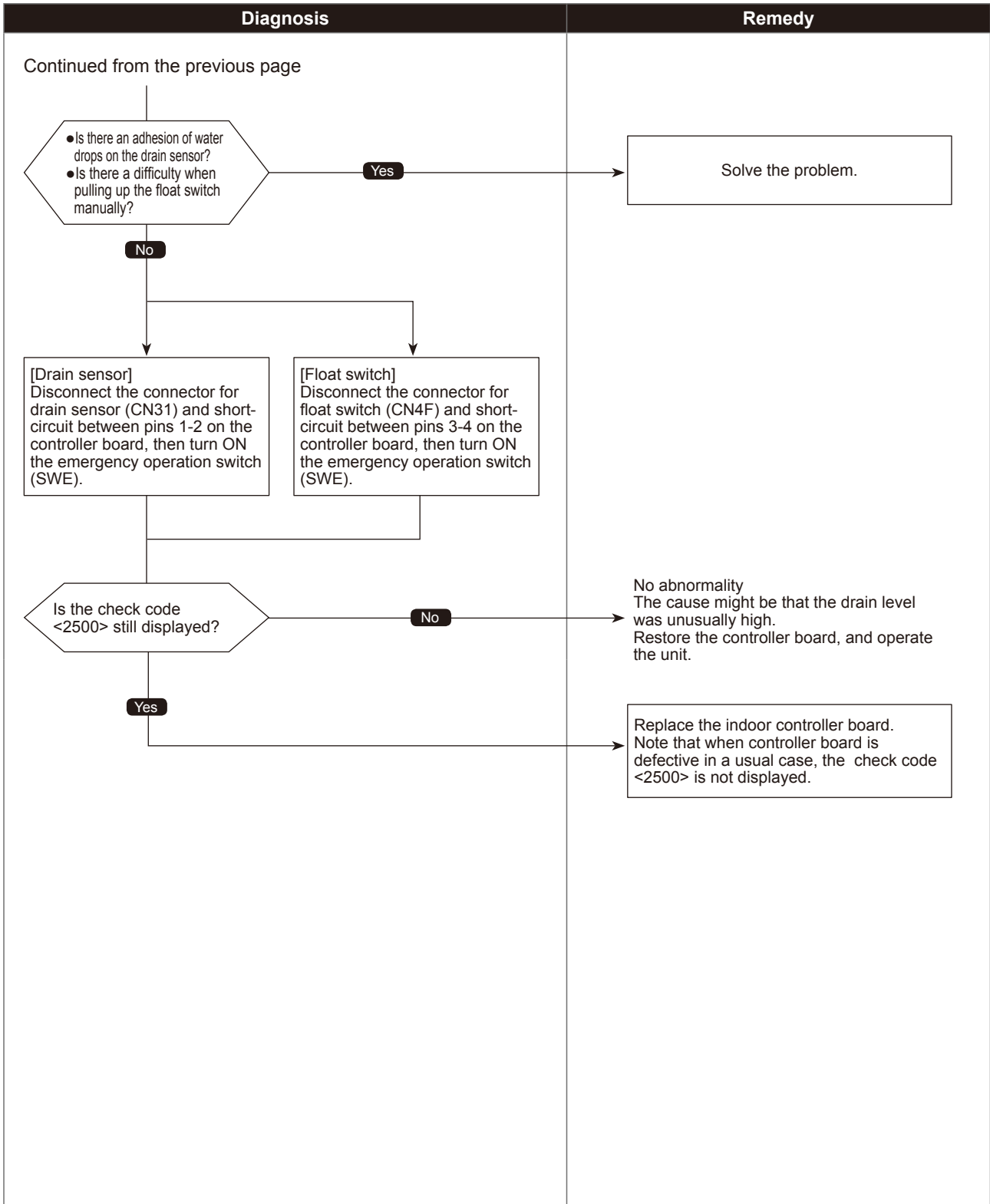

# Drain overflow protection

Abnormal points and detection methods	Causes and check points
<p><b>Drain pump (DP)</b></p> <p>① Let drain sensor self-heated, and if temperature rises slightly, as suspensive abnormality operation stops and changes to protect mode of restarting in 3 minutes.</p> <p>② Drain pump is abnormal if the condition above is detected during suspensive abnormality. &lt;2502&gt; is displayed.</p> <p>③ Malfunction of drain pipe is constantly detected during drain pump operation.</p> <p>④ The unit enters to forced outdoor unit stop when following conditions, ㉔ and ㉕, are satisfied (while the above mentioned detection is performed).</p> <p>㉔ The drain sensor detects to be soaked in the water 10 times in a row.</p> <p>㉕ Detected that [liquid pipe temperature - room temperature] ≤ -18°F [-10°C] for 30 minutes constantly.</p> <p><b>Notes:</b></p> <ol style="list-style-type: none"> <li>When the drain sensor detects to be NOT soaked in the water, the detection record of ㉔ and ㉕ will be cleared.</li> <li>Drain pump abnormality (above ①-③ is detected before it becomes an outdoor unit forced stop condition).</li> </ol> <p>⑤ When indoor unit detects above ④ condition, outdoor unit in the same refrigerant system stops. Also, indoor unit except for Fan or OFF mode unit stop. &lt;2502&gt; is displayed on stopped unit.</p> <p>⑥ Detection timing of forced outdoor unit stop Constantly detected during unit operation and stop</p> <p>⑦ Releasing of forced outdoor unit stop Reset power supply of both abnormal indoor unit and its outdoor unit in same refrigerant system. Forced outdoor unit stop cannot be released by remote controller OFF.</p> <p>Note: Above-mentioned ①-③ and ④-⑦ are detected independently.</p>	<p>① Malfunction of drain pump</p> <p>② Defective drain Clogged drain pump Clogged drain pipe</p> <p>③ Water drops on drain sensor Drops of drain trickles from lead wire Clogged filter is causing wave of drain</p> <p>④ Defective indoor controller board</p> <p>⑤ Both of above mentioned ①-④ and the indoor linear expansion valve full-closed failures (leakage) happen synchronistically</p> <p><b>Note:</b> Address/Attribute displayed on the remote controller shows the indoor unit which is the cause of trouble.</p>

● **Diagnosis of defectives**

Make sure to turn the power OFF before connecting/disconnecting any connectors, or replacing boards.

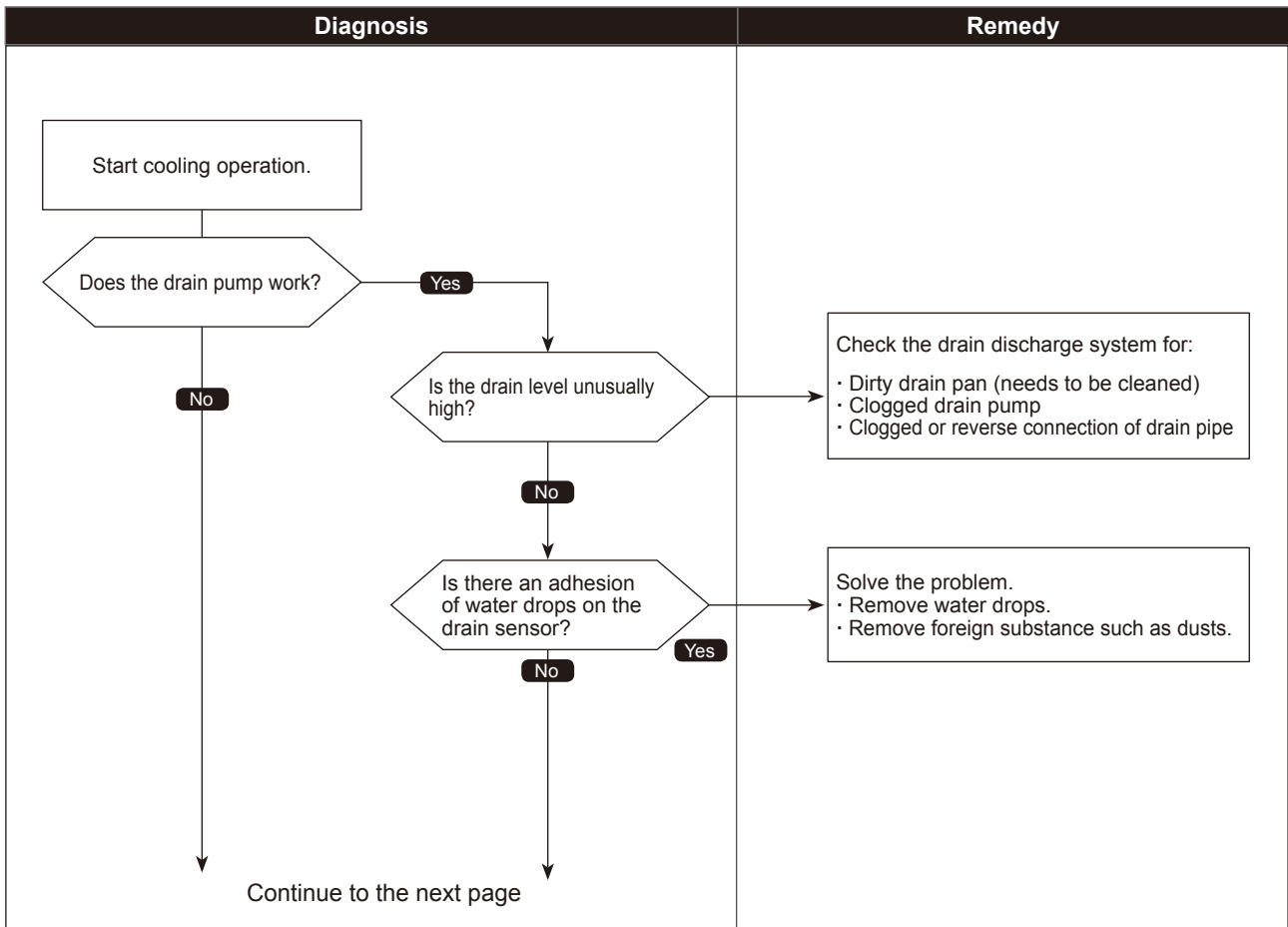

# Drain overflow protection

●Diagnosis of defectives

Make sure to turn the power OFF before connecting/disconnecting any connectors, or replacing boards.

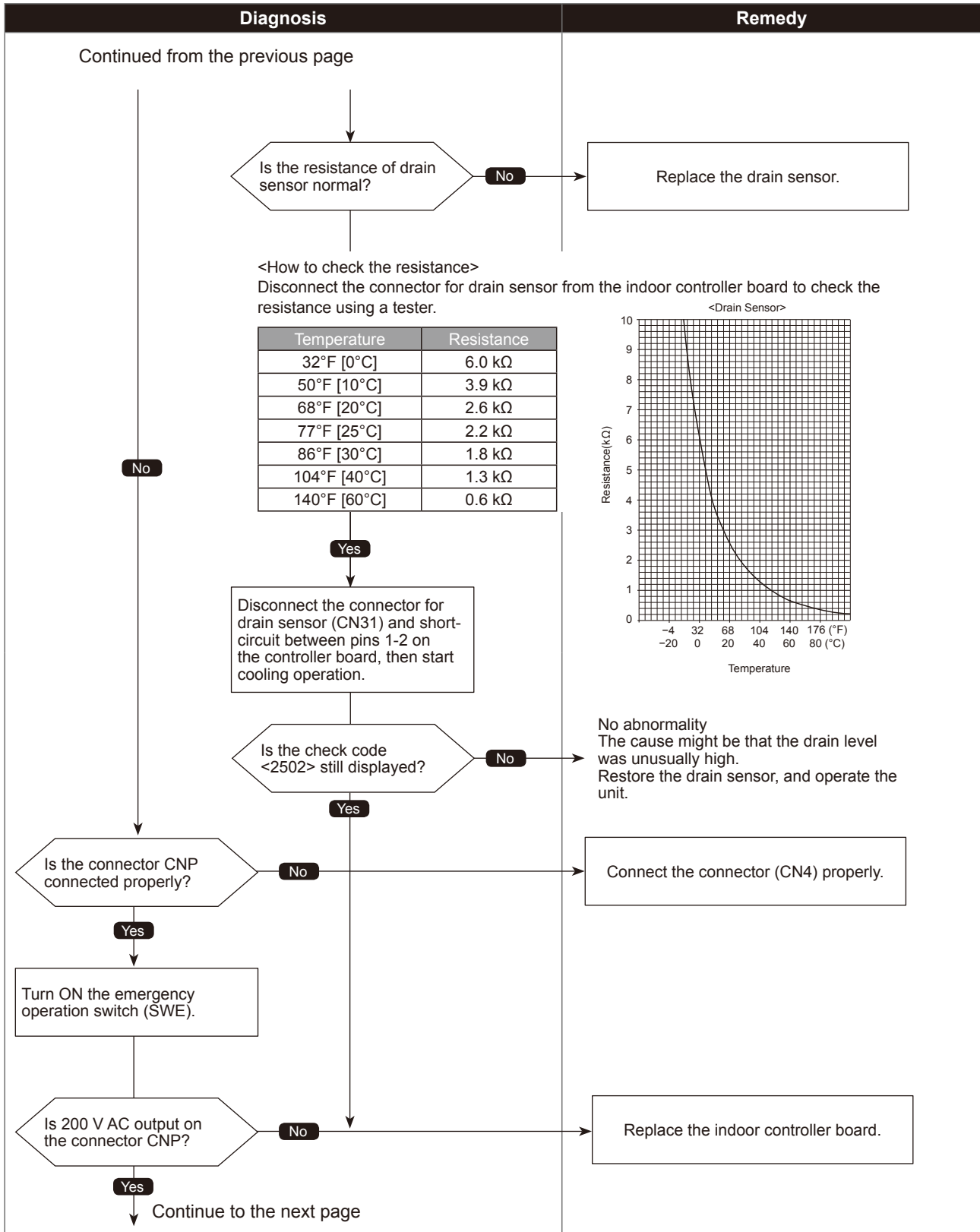

<Drain sensor models>  
Drain overflow protection

## ●Diagnosis of defectives

Make sure to turn the power OFF before connecting/disconnecting any connectors, or replacing boards.

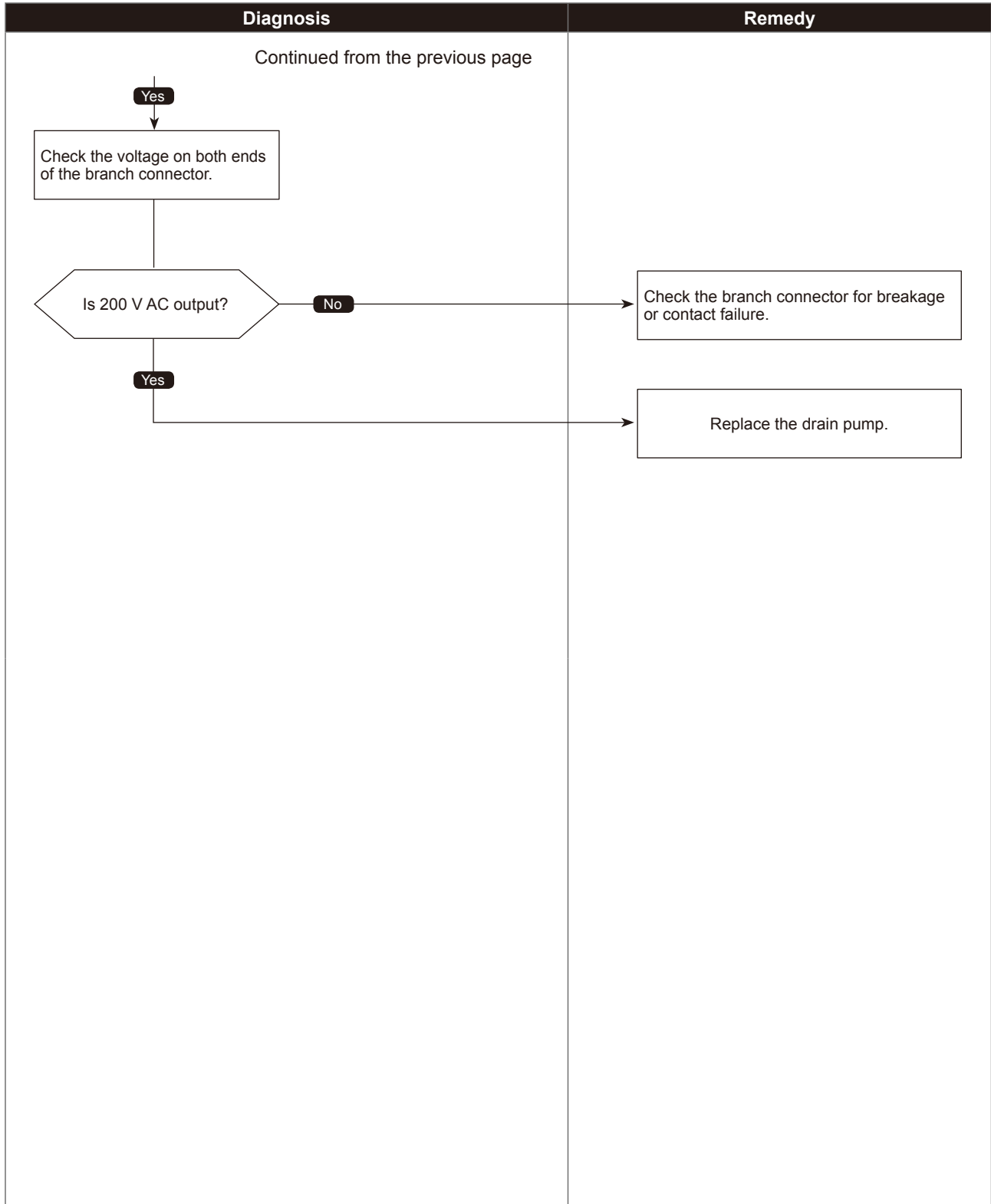

## <Float switch models> Drain overflow protection

Chart 1 of 2

Abnormal points and detection methods	Causes and check points
<p><b>Drain pump (DP)</b></p> <p>① Judge whether the sensor is in the water or in the air by turning the float switch ON/OFF. In the water: Detected that the float switch is ON for 15 seconds. In the air: Detected that the float switch is OFF for 15 seconds.</p> <p>② When the float switch remains to be turned ON for 3 minutes after detected to be in the water, the drain pump is judged to be abnormal and &lt;2502&gt; will be displayed. Note: It takes 3 minutes and 15 seconds to detect abnormality including the time to judge to be in the water.</p> <p>③ The unit continues to detect abnormality while turned off.</p> <p>④ When the conditions below 1, 2 and forced outdoor unit stop condition are met; 1. Detected that [liquid pipe temperature–room temperature] <math>\leq -18^{\circ}\text{F}</math> [<math>-10^{\circ}\text{C}</math>] for 30 minutes constantly. 2. Float switch detects to be in the water for 15 minutes constantly. Note: Before Forced outdoor unit stop condition is met, the unit always detects ①–③ above.</p> <p>⑤ The indoor unit detecting ④ above stops due to detecting abnormality the outdoor unit in same refrigerant system compressor is inhibited to operate). The unit which stops due to detecting abnormality displays &lt;2502&gt;.</p> <p>⑥ Detection timing of forced outdoor unit stop Constantly detected during unit operation and stop</p> <p>⑦ Releasing of forced outdoor unit stop Reset power supply of both abnormal indoor unit and its outdoor unit in same refrigerant system. Forced outdoor unit stop cannot be released by remote controller OFF.</p> <p>Note: Above-mentioned ①–③ and ④–⑦ are detected independently.</p>	<p>① Malfunction of drain pump</p> <p>② Defective drain Clogged drain pump Clogged drain pipe</p> <p>③ Defective moving part of float switch Foreign matter on the moving part of float switch (ex. sludge, etc.)</p> <p>④ Defective float switch</p> <p>⑤ Defective indoor controller board Defective driving circuit of drain pump Defective input circuit of float switch</p> <p>⑥ Both of above mentioned ① to ⑤ and the indoor linear expansion valve full-closed failures (leakage) happen synchronistically.</p> <p>Note: Address/Attribute displayed on the remote controller shows the indoor unit which is the cause of trouble.</p>

### ●Diagnosis of defectives

Make sure to turn the power OFF before connecting/disconnecting any connectors, or replacing boards

Diagnosis	Remedy
<pre> graph TD     Start[Start cooling operation.] --&gt; Q1{Does the drain pump work?}     Q1 -- No --&gt; Next[Continue to the next page]     Q1 -- Yes --&gt; Q2{Is the drain level unusually high?}     Q2 -- No --&gt; Next     Q2 -- Yes --&gt; Remedy[Check the drain discharge system for: · Dirty drain pan (needs to be cleaned) · Clogged drain pump · Clogged or reverse connection of drain pipe]           </pre>	<p>Check the drain discharge system for:</p> <ul style="list-style-type: none"> <li>· Dirty drain pan (needs to be cleaned)</li> <li>· Clogged drain pump</li> <li>· Clogged or reverse connection of drain pipe</li> </ul>

# <Float switch models> Drain overflow protection

●Diagnosis of defectives

Make sure to turn the power OFF before connecting/disconnecting any connectors, or replacing boards.

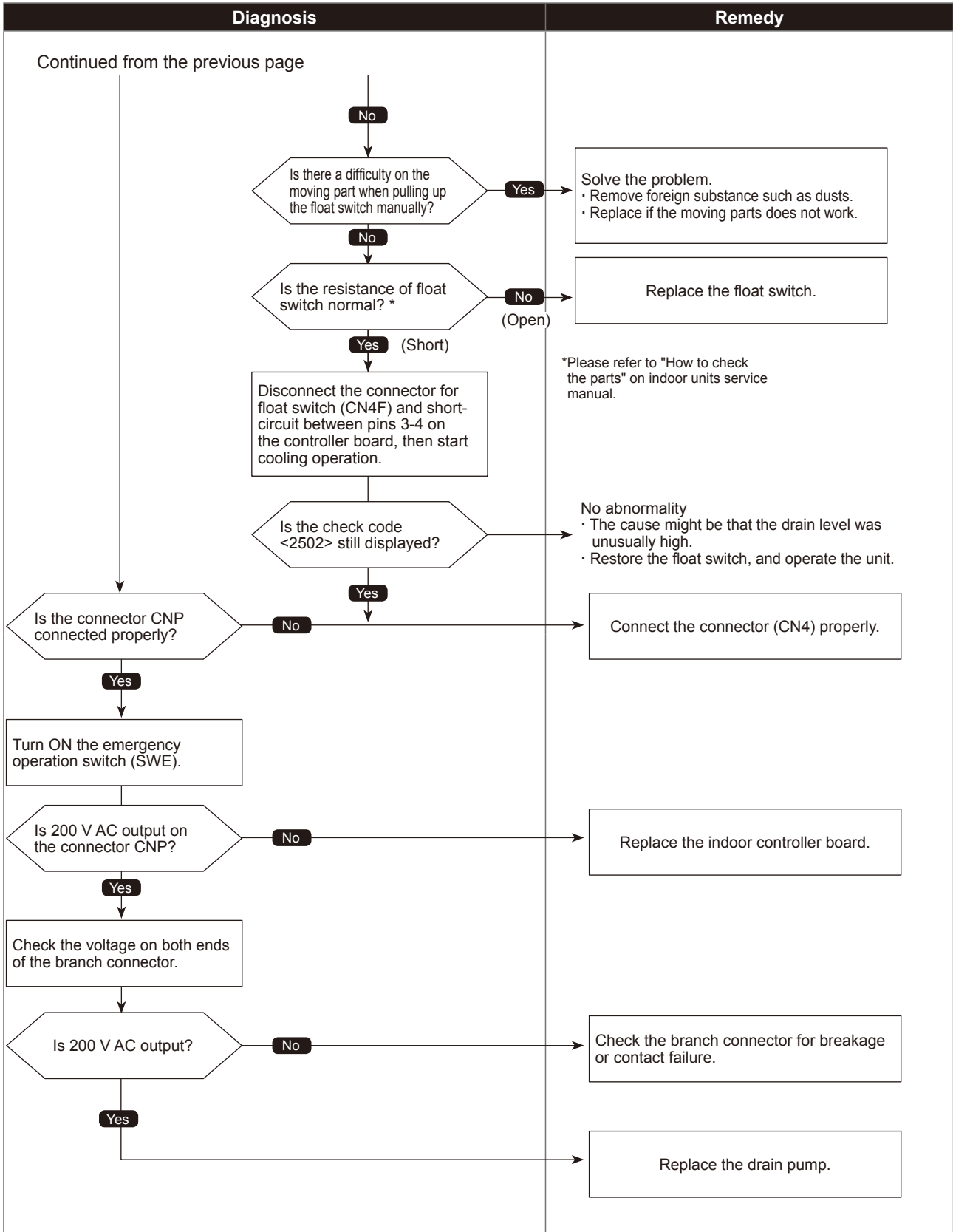

## <Drain sensor models> Drain sensor abnormality

Abnormal points and detection methods	Causes and check points
<Drain sensor models> Abnormal if drain sensor detects to be short/open.	① Contact failure of connector CN31 ② Characteristic defect of thermistor ③ Breakage or contact failure of drain sensor wiring ④ Replace the indoor controller board.

●Diagnosis of defectives

Make sure to turn the power OFF before connecting/disconnecting any connectors, or replacing boards

Diagnosis	Remedy																
<p style="text-align: center;">[Drain sensor models]</p> <div style="border: 1px solid black; padding: 5px; margin-bottom: 10px; text-align: center;">                     Check the drain sensor connector (CN31) for disconnection or looseness.                 </div> <div style="text-align: center;"> <div style="border: 1px solid black; width: 150px; height: 40px; margin: 0 auto; display: flex; align-items: center; justify-content: center;">                     Is it connected normally?                 </div> <div style="display: flex; justify-content: space-around; margin-top: 5px;"> <div style="border: 1px solid black; padding: 2px 5px;">No</div> <div style="border: 1px solid black; padding: 2px 5px;">Yes</div> </div> </div> <div style="margin-top: 20px;"> <div style="border: 1px solid black; width: 150px; height: 40px; margin: 0 auto; display: flex; align-items: center; justify-content: center;">                     Is the resistance of thermistor normal?                 </div> <div style="display: flex; justify-content: space-around; margin-top: 5px;"> <div style="border: 1px solid black; padding: 2px 5px;">No</div> <div style="border: 1px solid black; padding: 2px 5px;">Yes</div> </div> </div>	<div style="border: 1px solid black; padding: 5px; margin-bottom: 20px; text-align: center;">                     Connect it properly.                      Turn the power back ON, then check the operation.                 </div> <div style="border: 1px solid black; padding: 5px; margin-bottom: 20px; text-align: center;">                     Replace the drain sensor.                 </div> <div style="border: 1px solid black; padding: 5px; text-align: center;">                     Replace the indoor controller board.                 </div>																
<p>&lt;How to check the resistance&gt;                      Disconnect the connector for drain sensor from the indoor controller board to check the resistance using a tester.</p> <table border="1" style="width: 100%; border-collapse: collapse; margin-bottom: 10px;"> <thead> <tr style="background-color: #ccc;"> <th style="text-align: center;">Temperature</th> <th style="text-align: center;">Resistance</th> </tr> </thead> <tbody> <tr><td style="text-align: center;">32°F [0°C]</td><td style="text-align: center;">6.0 kΩ</td></tr> <tr><td style="text-align: center;">50°F [10°C]</td><td style="text-align: center;">3.9 kΩ</td></tr> <tr><td style="text-align: center;">68°F [20°C]</td><td style="text-align: center;">2.6 kΩ</td></tr> <tr><td style="text-align: center;">77°F [25°C]</td><td style="text-align: center;">2.2 kΩ</td></tr> <tr><td style="text-align: center;">86°F [30°C]</td><td style="text-align: center;">1.8 kΩ</td></tr> <tr><td style="text-align: center;">104°F [40°C]</td><td style="text-align: center;">1.3 kΩ</td></tr> <tr><td style="text-align: center;">140°F [60°C]</td><td style="text-align: center;">0.6 kΩ</td></tr> </tbody> </table> <div style="text-align: right;"> <p style="text-align: center; font-size: small;">&lt;Drain Sensor&gt;</p> </div>		Temperature	Resistance	32°F [0°C]	6.0 kΩ	50°F [10°C]	3.9 kΩ	68°F [20°C]	2.6 kΩ	77°F [25°C]	2.2 kΩ	86°F [30°C]	1.8 kΩ	104°F [40°C]	1.3 kΩ	140°F [60°C]	0.6 kΩ
Temperature	Resistance																
32°F [0°C]	6.0 kΩ																
50°F [10°C]	3.9 kΩ																
68°F [20°C]	2.6 kΩ																
77°F [25°C]	2.2 kΩ																
86°F [30°C]	1.8 kΩ																
104°F [40°C]	1.3 kΩ																
140°F [60°C]	0.6 kΩ																

# Compressor current interruption (Locked compressor)

Abnormal points and detection methods	Causes and check points
Abnormal if overcurrent of DC bus or compressor is detected 30 seconds after the compressor starts operating.	<ul style="list-style-type: none"> <li>① Closed stop valve</li> <li>② Decrease of power supply voltage</li> <li>③ Looseness, disconnection or converse of compressor wiring connection</li> <li>④ Model selection error upon replacement of indoor controller board</li> <li>⑤ Defective compressor</li> <li>⑥ Defective outdoor power circuit board</li> </ul>

●Diagnosis of defectives

Make sure to turn the power OFF before connecting/disconnecting any connectors, or replacing boards.

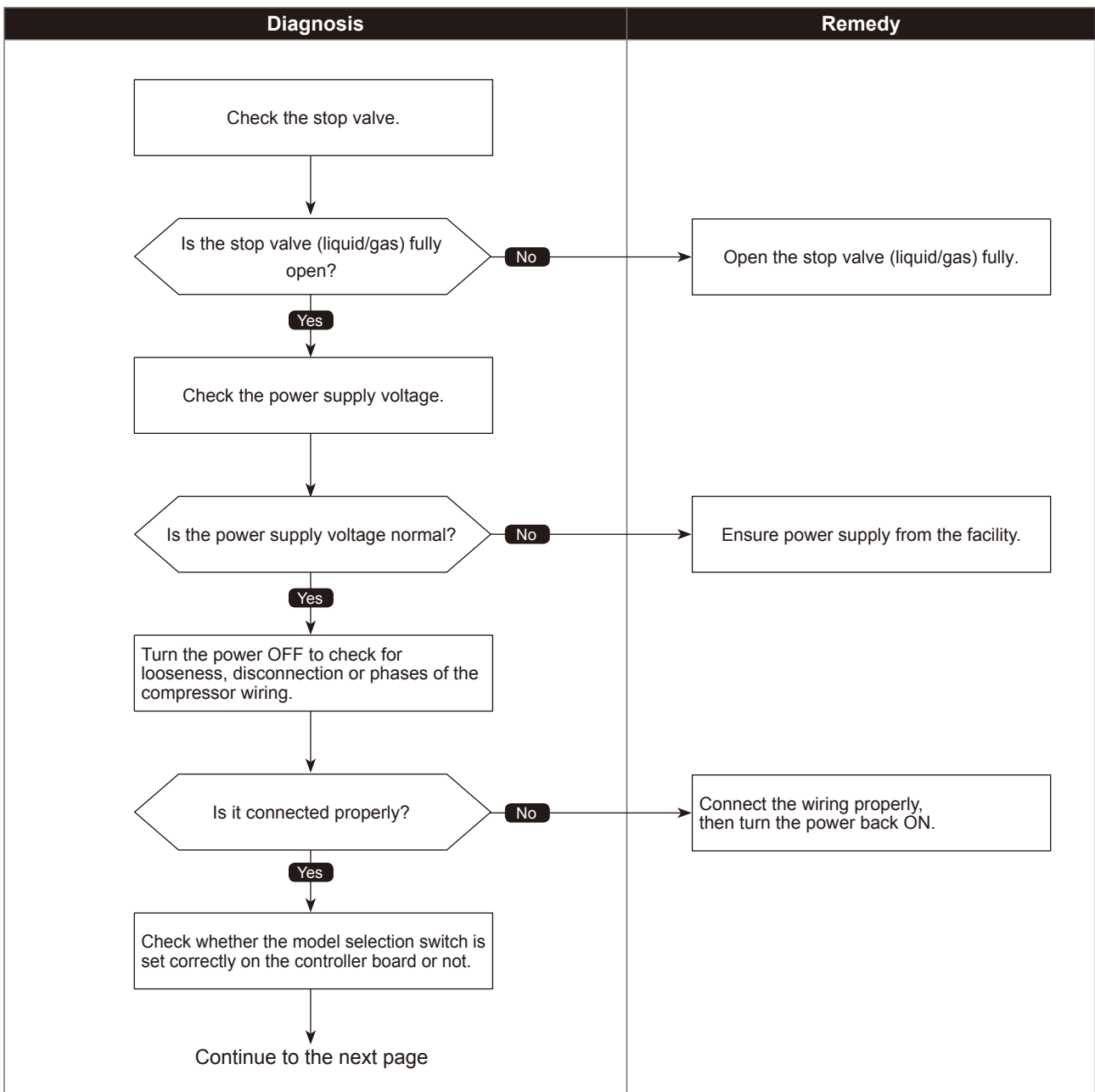

## ●Diagnosis of defectives

Make sure to turn the power OFF before connecting/disconnecting any connectors, or replacing boards.

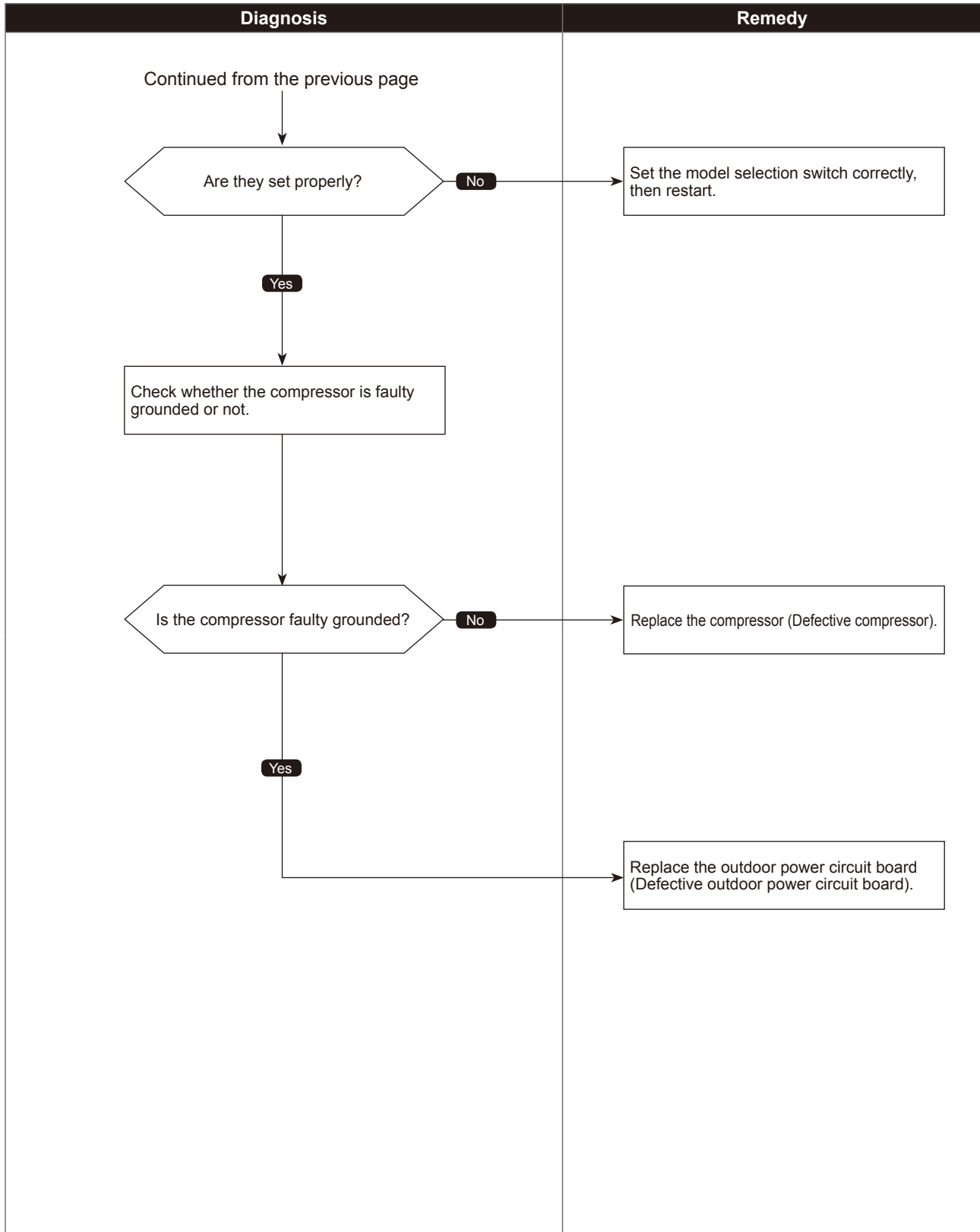

## Compressor overcurrent interruption

Abnormal points and detection methods	Causes and check points
Abnormal if overcurrent of DC or the compressor is detected within 30 seconds after the compressor starts operating.	<ul style="list-style-type: none"> <li>① Closed outdoor stop valve</li> <li>② Decrease of power supply voltage</li> <li>③ Looseness, disconnection or reverse phase of compressor wiring connection</li> <li>④ Malfunction of indoor/outdoor fan</li> <li>⑤ Short-cycle of indoor/outdoor unit</li> <li>⑥ Model selection error upon replacement of outdoor controller board</li> <li>⑦ Malfunction of input circuit on outdoor controller board</li> <li>⑧ Defective compressor</li> <li>⑨ Defective outdoor power circuit board</li> </ul>

## ●Diagnosis of defectives

Make sure to turn the power OFF before connecting/disconnecting any connectors, or replacing boards.

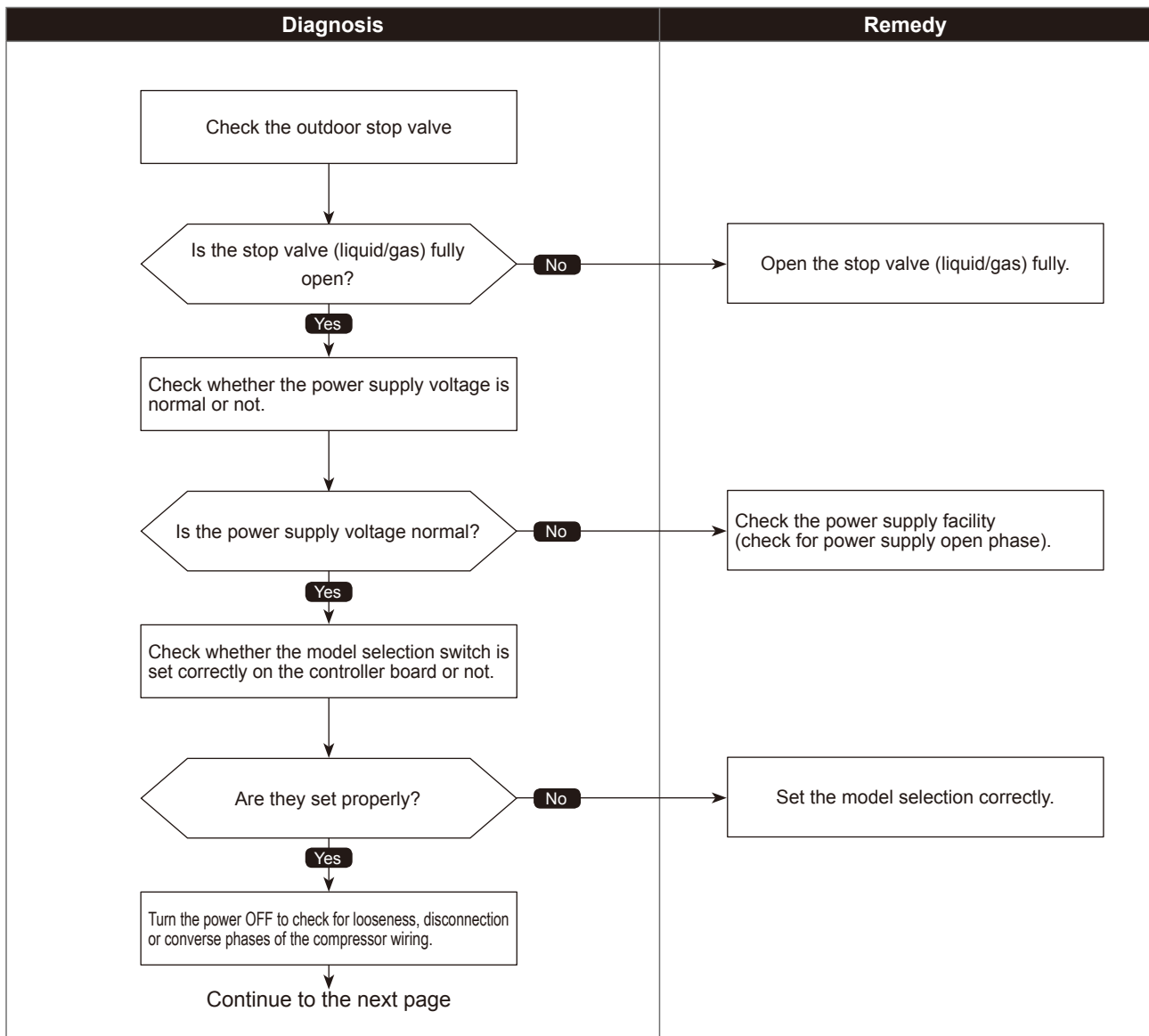

# Compressor overcurrent interruption

●Diagnosis of defectives

Make sure to turn the power OFF before connecting/disconnecting any connectors, or replacing boards.

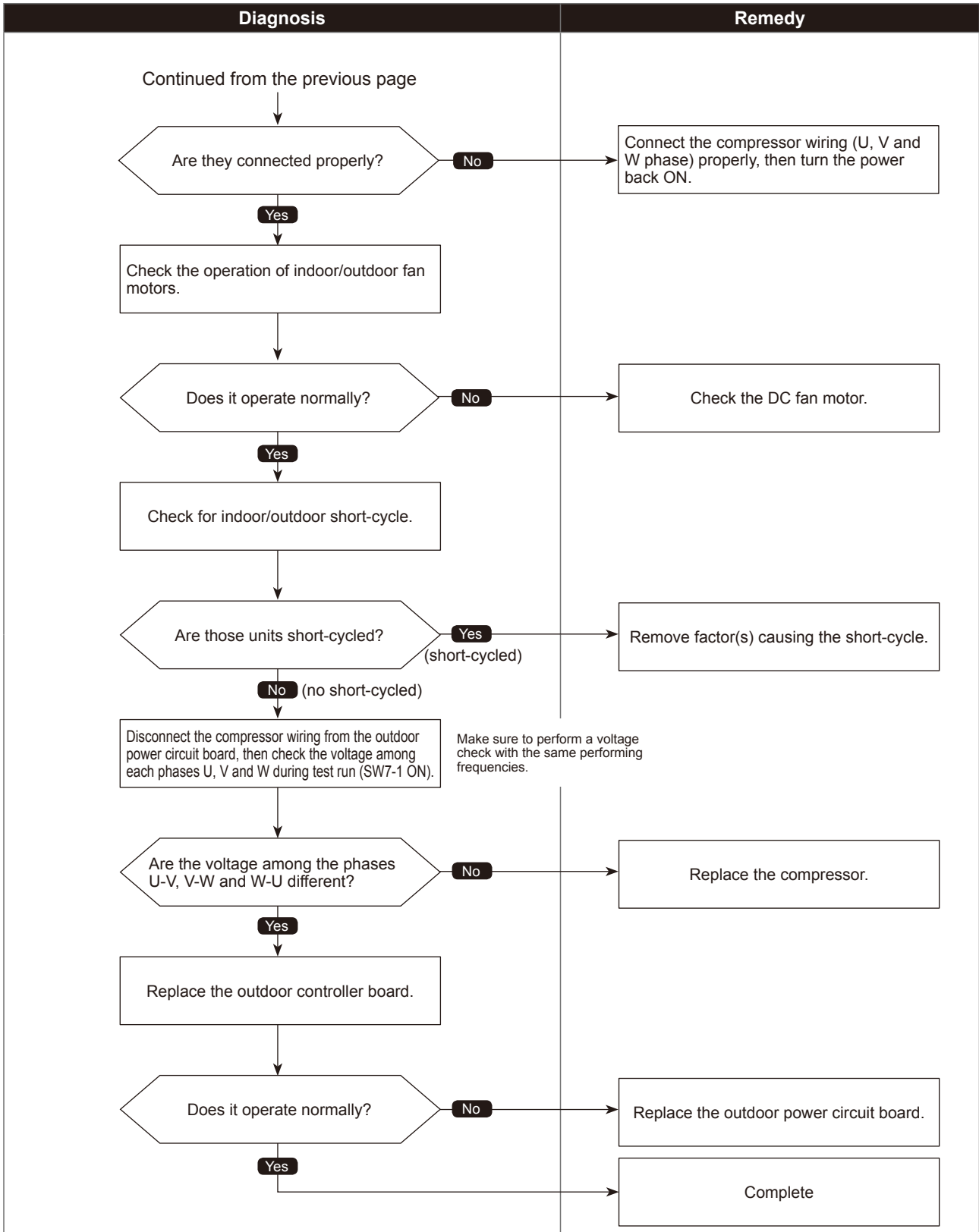

# Undervoltage/Overvoltage/PAM error/L1 open-phase/ Primary current sensor error/Power synchronization signal error

Abnormal points and detection methods	Causes and check points
<p>Abnormal if any of following symptoms are detected;</p> <ul style="list-style-type: none"> <li>● Decrease of DC bus voltage to 200 V (V,N model), 350 V (Y model)</li> <li>● Increase of DC bus voltage to 400 V (V,N model), 760 V (Y model)</li> <li>● DC bus voltage stays at 310 V or lower for consecutive 10 seconds</li> <li>● When any of the following conditions is satisfied while the detection value of primary current is 0.1 A or less.                             <ol style="list-style-type: none"> <li>1. The operational frequency is 40 Hz or more.</li> <li>2. The compressor current is 6 A or more.</li> </ol> </li> </ul> <p>Note: V,N model is single phase power supply model. Y model is three phase power supply model.</p>	<ol style="list-style-type: none"> <li>① Decrease/increase of power supply voltage,</li> <li>② LI open-phase (Y model only)</li> <li>③ Primary current sensor failure</li> <li>④ Disconnection of compressor wiring</li> <li>⑤ Malfunction of 52C</li> <li>⑥ Disconnection or contact failure of CN52C</li> <li>⑦ Defective outdoor power circuit board</li> <li>⑧ Malfunction of 52C driving circuit on outdoor multi controller circuit board</li> <li>⑨ Disconnection of CN5</li> <li>⑩ Disconnection of CN2</li> <li>⑪ Malfunction of primary current detecting circuit on outdoor power circuit board</li> </ol>

● Diagnosis of defectives

Make sure to turn the power OFF before connecting/disconnecting any connectors, or replacing boards.

The black square (■) indicates a switch position.

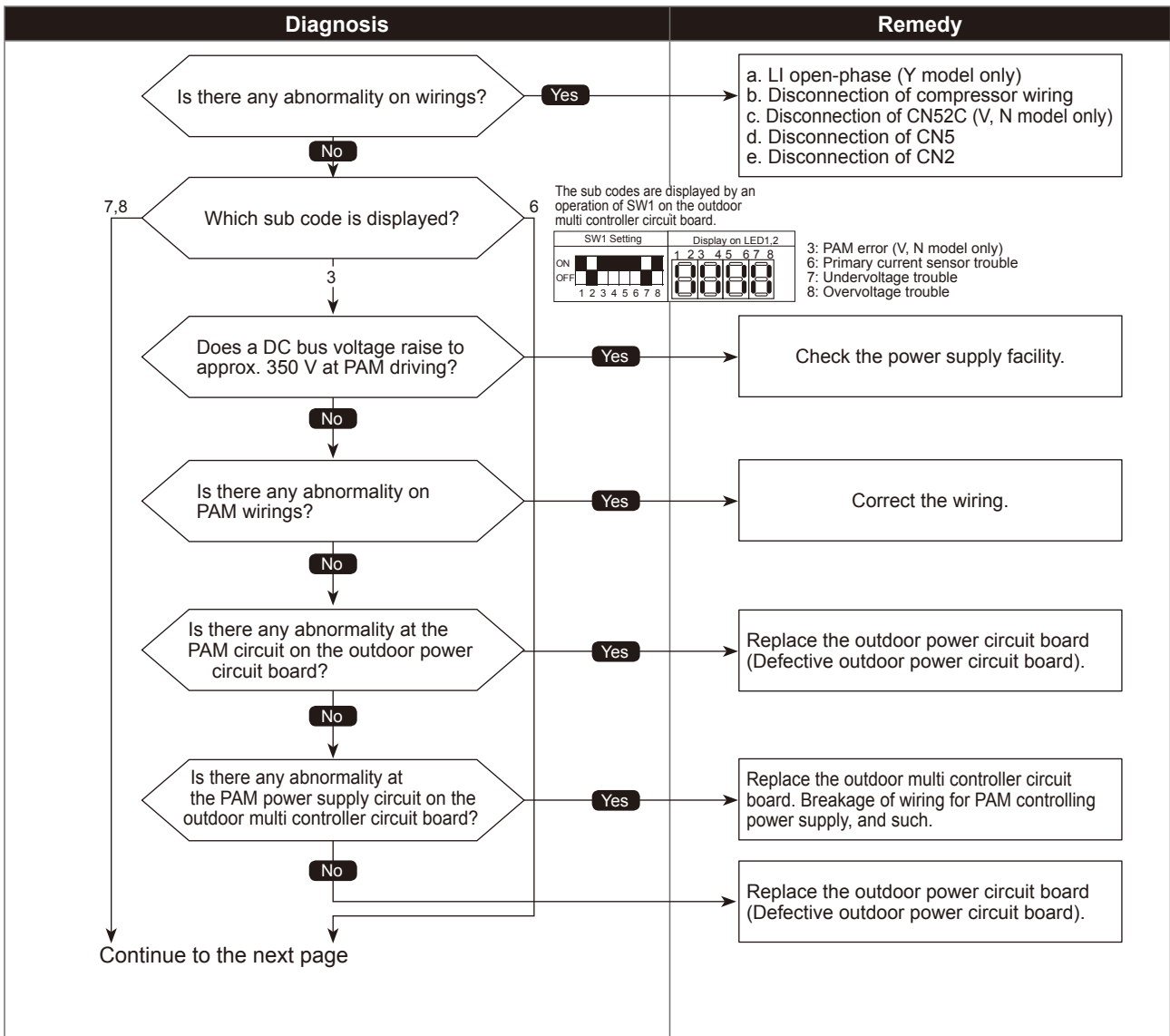

# Undervoltage/Overvoltage/PAM error/L1 open-phase/ Primary current sensor error/Power synchronization signal error

●Diagnosis of defectives

Make sure to turn the power OFF before connecting/disconnecting any connectors, or replacing boards.

The black square (■) indicates a switch position.

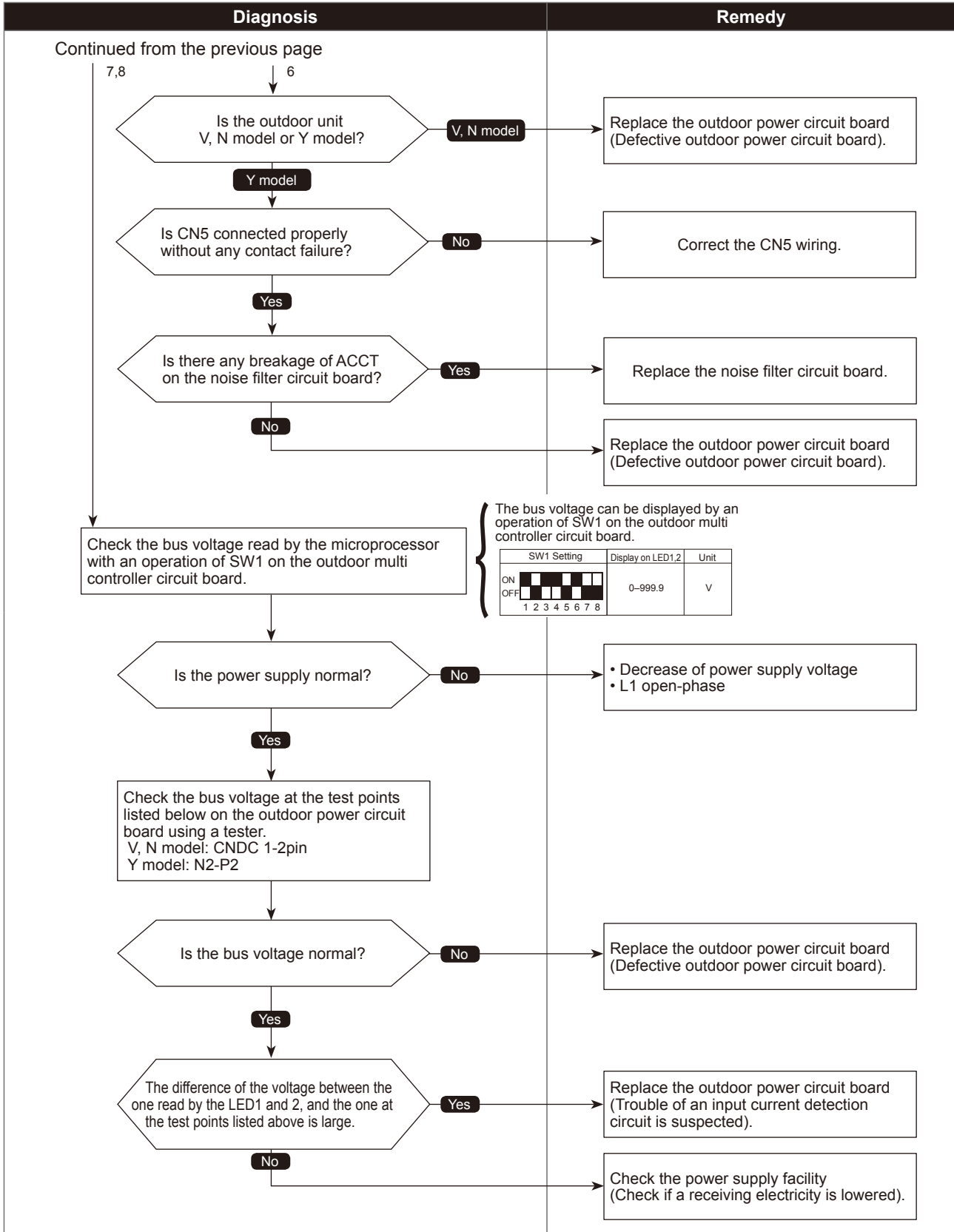

## Heat sink temperature trouble

Abnormal points and detection methods	Causes and check points
<p>Abnormal if TH8 detects a temperature outside the specified range during compressor operation.</p> <p>TH8: Thermistor &lt;Heat sink&gt;</p>	<ul style="list-style-type: none"> <li>① Blocked outdoor fan</li> <li>② Malfunction of outdoor fan motor</li> <li>③ Blocked airflow path</li> <li>④ Rise of ambient temperature</li> <li>⑤ Characteristic defect of thermistor</li> <li>⑥ Malfunction of input circuit on outdoor power circuit board</li> <li>⑦ Malfunction of outdoor fan driving circuit</li> </ul>

## ●Diagnosis of defectives

Make sure to turn the power OFF before connecting/disconnecting any connectors, or replacing boards.

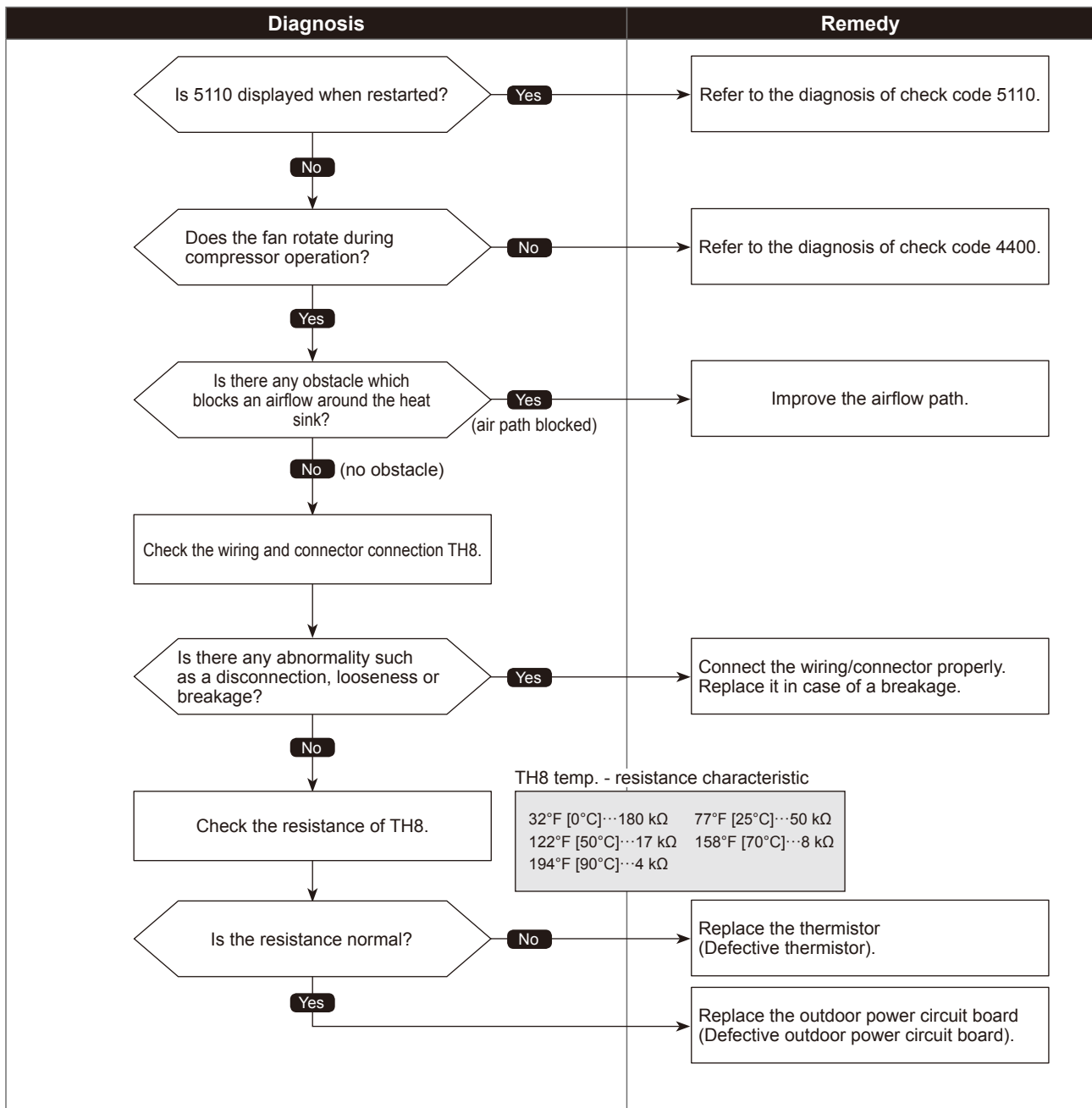

## Power module trouble

Abnormal points and detection methods	Causes and check points
Abnormal if overcurrent of DC bus or compressor is detected 30 seconds after the compressor starts operating. To determine the source of abnormality, either the compressor or the power module, drive the power module forcibly.	<ul style="list-style-type: none"> <li>① Closed outdoor stop valve</li> <li>② Decrease of power supply voltage</li> <li>③ Disconnection, looseness or conversed connection of compressor wiring</li> <li>④ Defective compressor</li> <li>⑤ Defective outdoor power circuit board</li> </ul>

## ●Diagnosis of defectives

Make sure to turn the power OFF before connecting/disconnecting any connectors, or replacing boards.

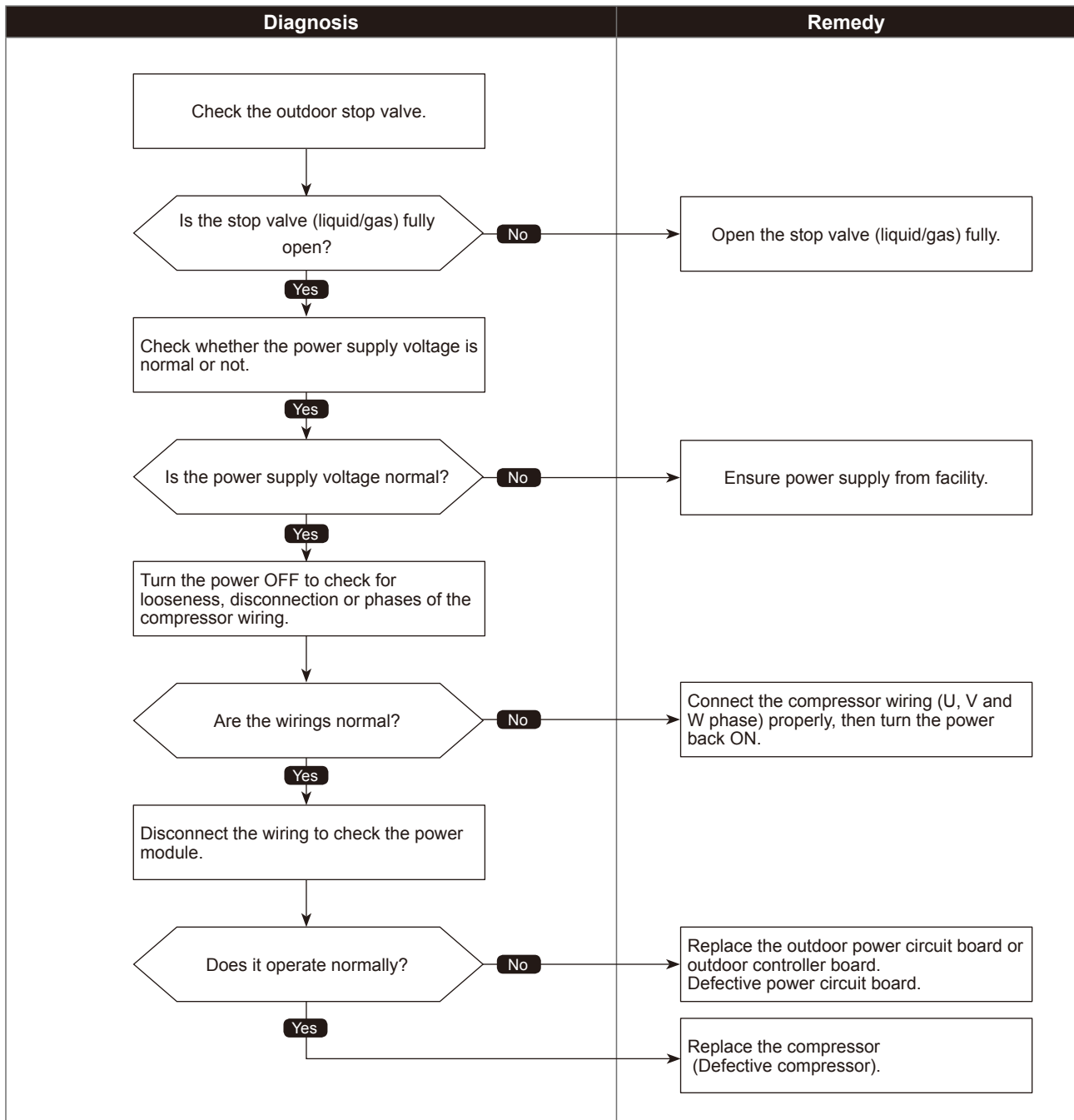

## Rotational frequency of outdoor fan motor trouble

Abnormal points and detection methods	Causes and check points
Abnormal if no rotational frequency is detected, or detected a value outside the specified range during fan motor operation.	① Malfunction of fan motor ② Disconnection of CNF connector ③ Defective outdoor controller board

## ●Diagnosis of defectives

Make sure to turn the power OFF before connecting/disconnecting any connectors, or replacing boards.

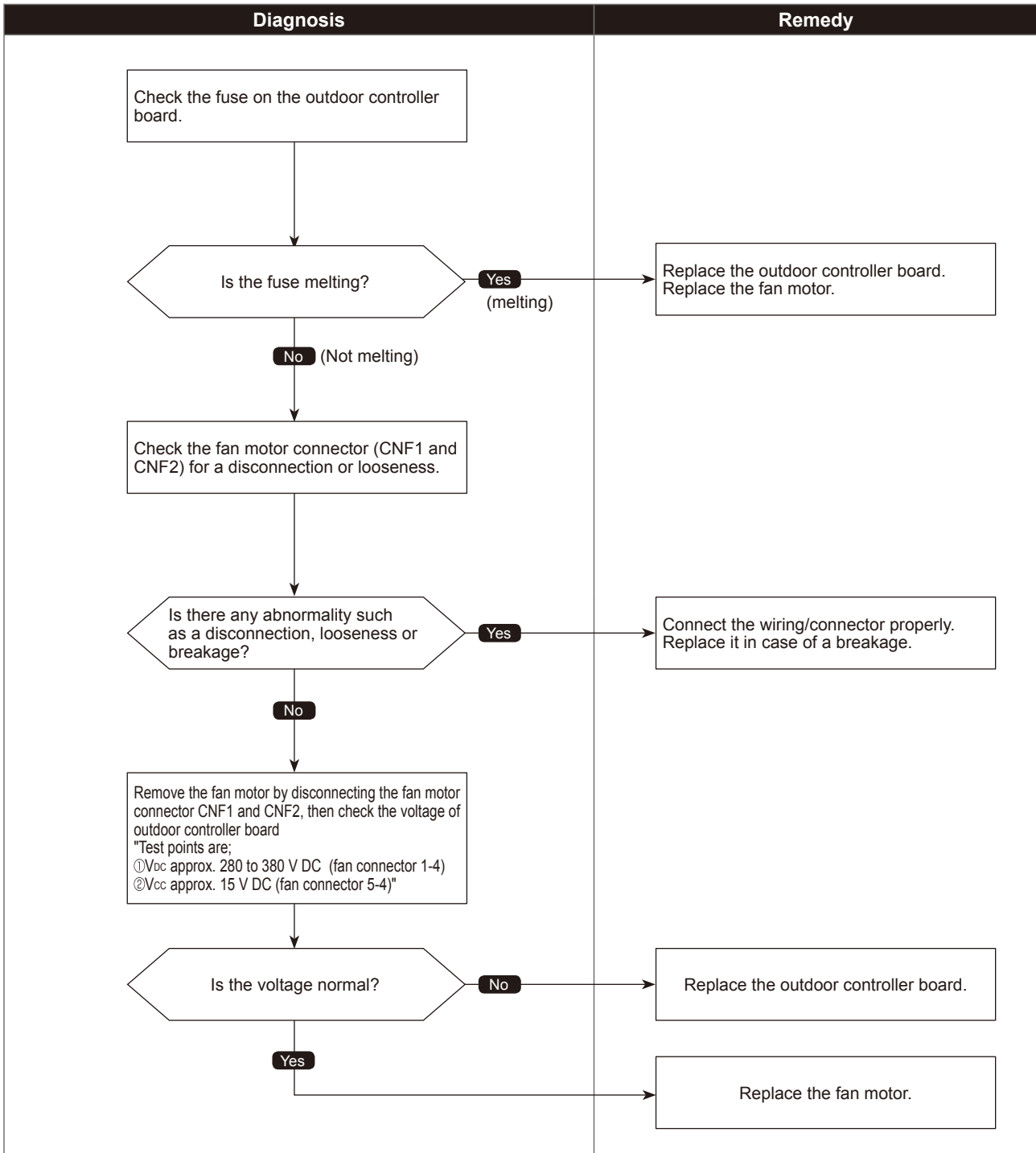

# Compressor temperature thermistor (TH4) open/short

<Detected in outdoor unit>

Abnormal points and detection methods	Causes and check points
Abnormal if TH4 detects to be open/short. (The open/short detection is disabled for 10 minutes after compressor starts, during defrosting operation, or for 10 minutes after returning from the defrosting operation.) Open: 37.4°F [3°C] or less Short: 422.6°F [217°C] or more TH4: Thermistor <Discharge/compressor>	① Disconnection or contact failure of connectors ② Characteristic defect of thermistor ③ Defective outdoor controller board

● Diagnosis of defectives

Make sure to turn the power OFF before connecting/disconnecting any connectors, or replacing boards.

The black square (■) indicates a switch position.

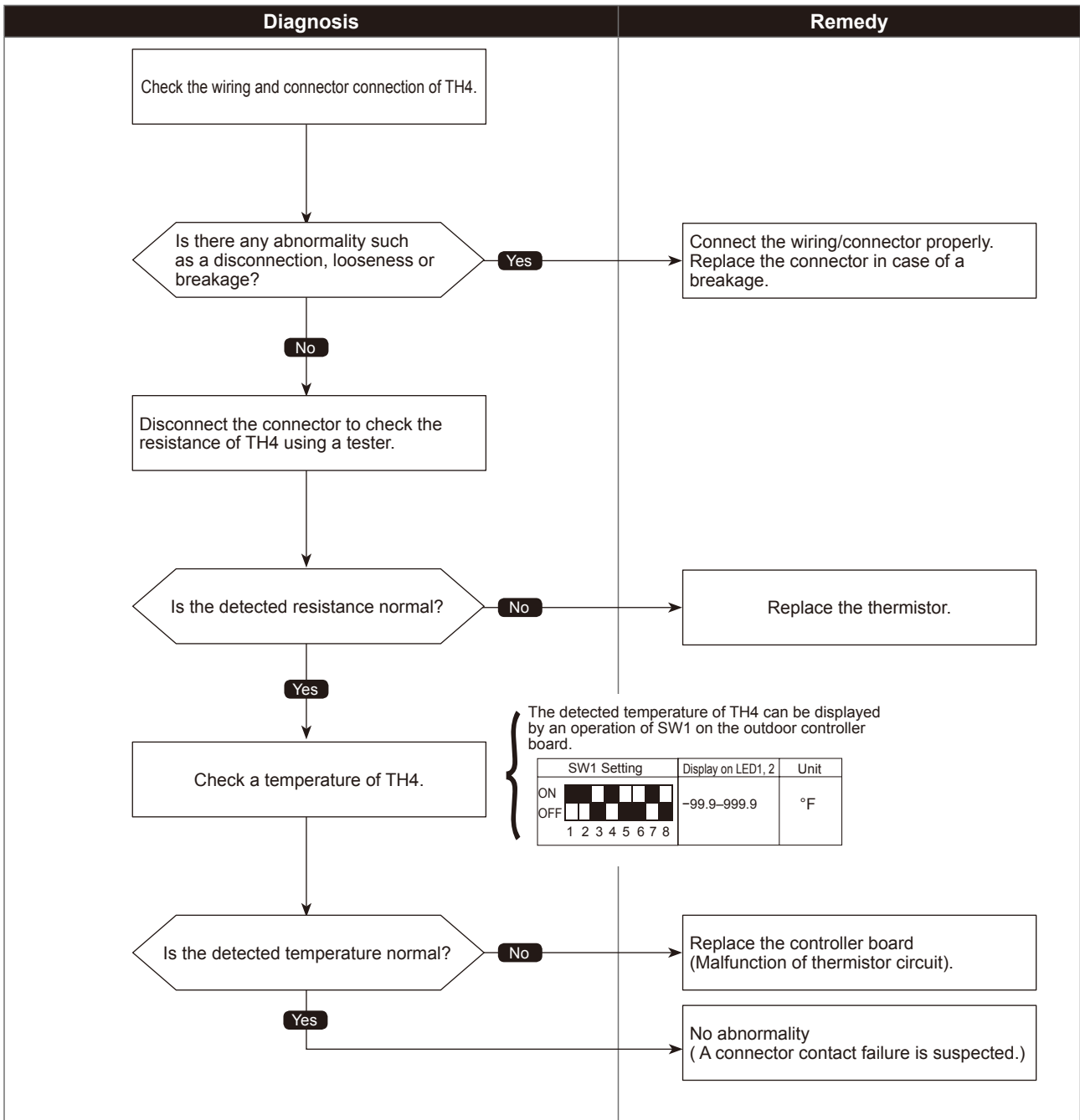

# Suction pipe temperature thermistor (TH6) open/short

<Detected in outdoor unit>

Abnormal points and detection methods	Causes and check points
Abnormal if TH6 detects to be open/short. (The open/short detection is disabled during 10 seconds to 10 minutes after compressor starts, during defrosting operation, or for 10 minutes after returning from the defrosting operation.) Open: -40°C [-40°F] or less Short: 194°F [90°C] or more TH6: Thermistor <Low Pressure Saturated>	① Disconnection or contact failure of connectors ② Characteristic defect of thermistor ③ Defective outdoor controller board

●Diagnosis of defectives

Make sure to turn the power OFF before connecting/disconnecting any connectors, or replacing boards.

The black square (■) indicates a switch position.

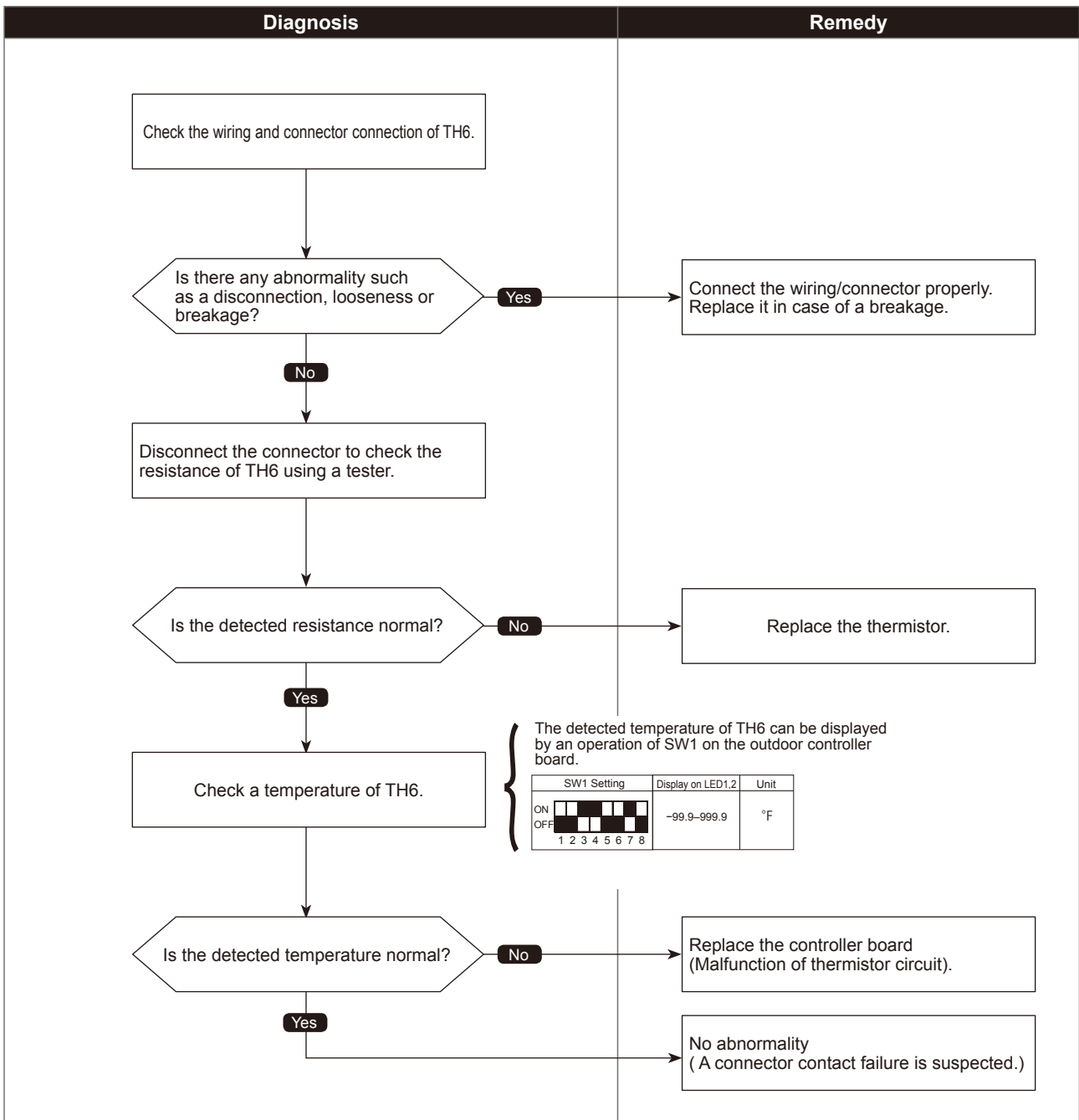

Check code

5101, 5102, 5103

## Air inlet thermistor trouble (TH21) Liquid pipe temperature thermistor trouble (TH22) Gas pipe temperature thermistor trouble (TH23)

<Detected in indoor unit>

Abnormal points and detection methods	Causes and check points
<p>Abnormal if any of the following thermistor detected to be open/short.</p> <p>TH21: Air inlet thermistor TH22: Liquid pipe temperature thermistor TH23: Gas pipe temperature thermistor</p>	<p>① Contact failure of connectors ② Characteristic defect of thermistor ③ Disconnection or contact failure of thermistor ④ Defective indoor controller board</p>

●Diagnosis of defectives

Make sure to turn the power OFF before connecting/disconnecting any connectors, or replacing boards.

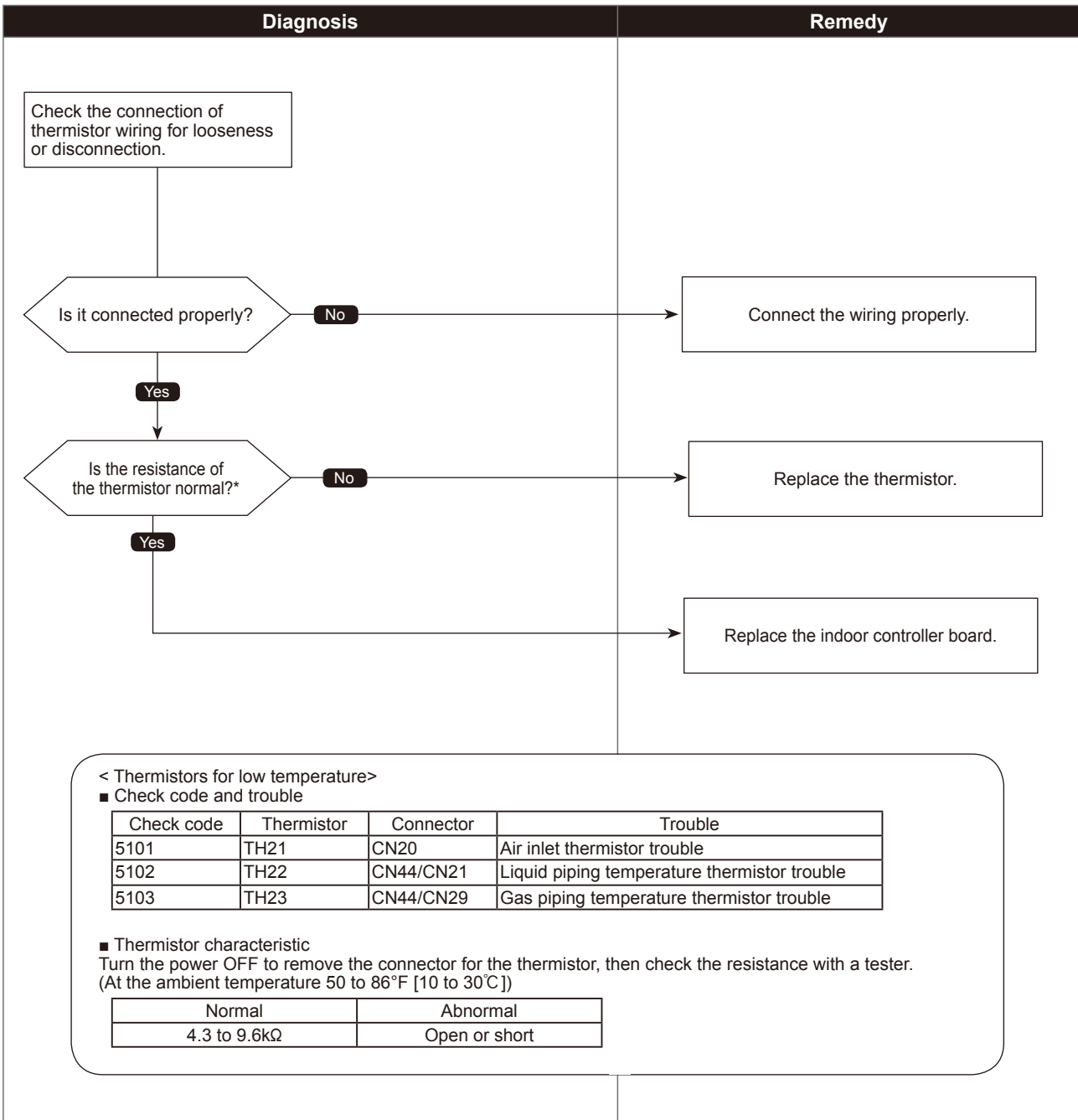

\* Symbols for thermistors and connectors may be different depending on the model. Please refer to its wiring diagram.

# Outdoor pipe temperature thermistor (TH3) open/short

Abnormal points and detection methods	Causes and check points
Abnormal if TH3 detects to be open/short. (The open/short detection is disabled during 10 seconds to 10 minutes after compressor starts, during defrosting operation, or for 10 minutes after returning from the defrosting operation.) Open: -40°F [-40°C] or less Short: 194°F [90°C] or more      TH3: Thermistor <Outdoor pipe>	① Disconnection or contact failure of connectors ② Characteristic defect of thermistor ③ Defective outdoor controller board

●Diagnosis of defectives

Make sure to turn the power OFF before connecting/disconnecting any connectors, or replacing boards.

The black square (■) indicates a switch position.

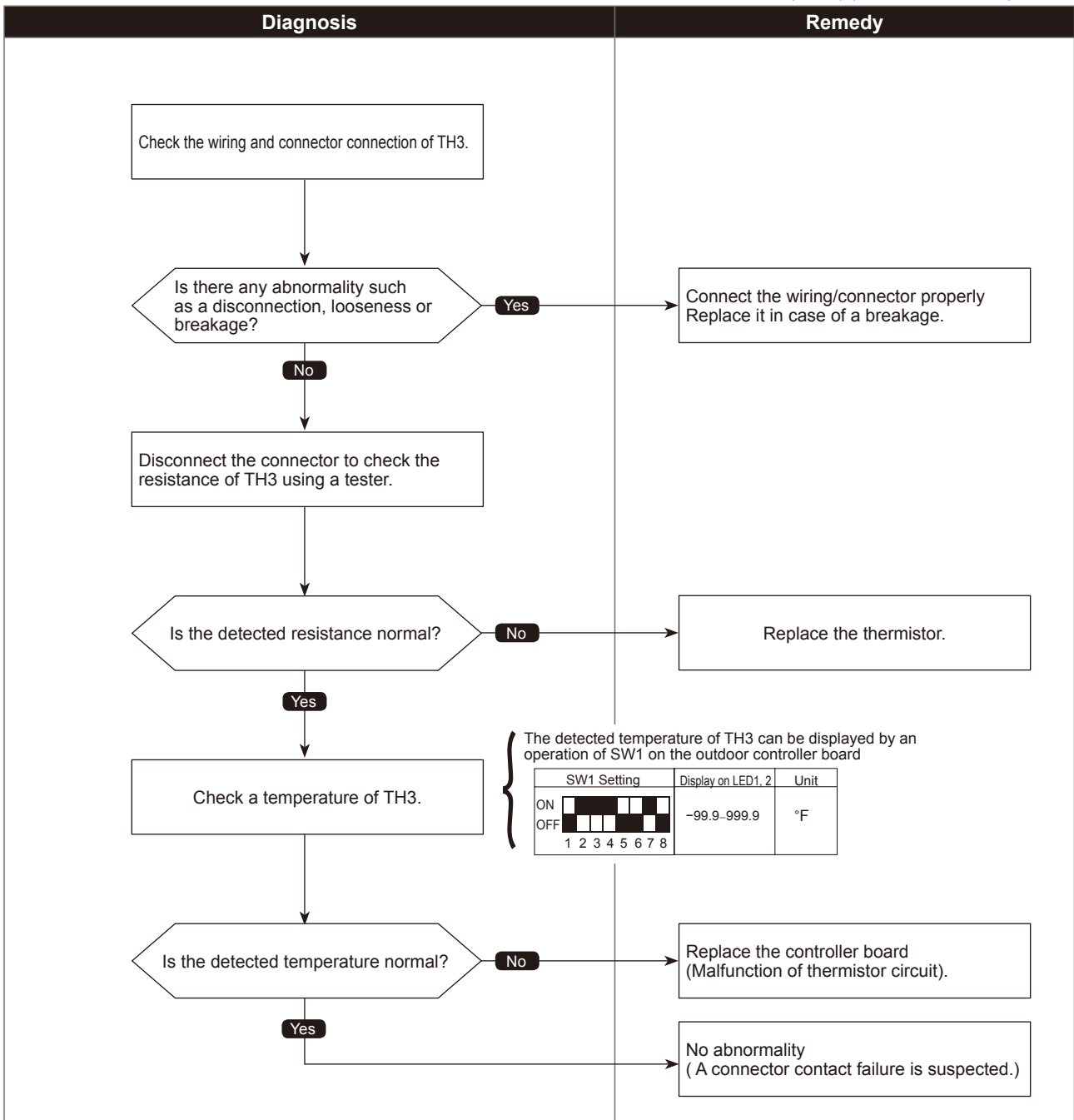

# Outdoor thermistor (TH7) open/short

Abnormal points and detection methods	Causes and check points
Abnormal if TH7 detects to be open/short. Open: -40°F [-40°C] or less Short: 194°F [90°C] or more      TH7: Thermistor <Outdoor>	① Disconnection or contact failure of connectors ② Characteristic defect of thermistor ③ Defective outdoor controller board

●Diagnosis of defectives

Make sure to turn the power OFF before connecting/disconnecting any connectors, or replacing boards.

The black square (■) indicates a switch position.

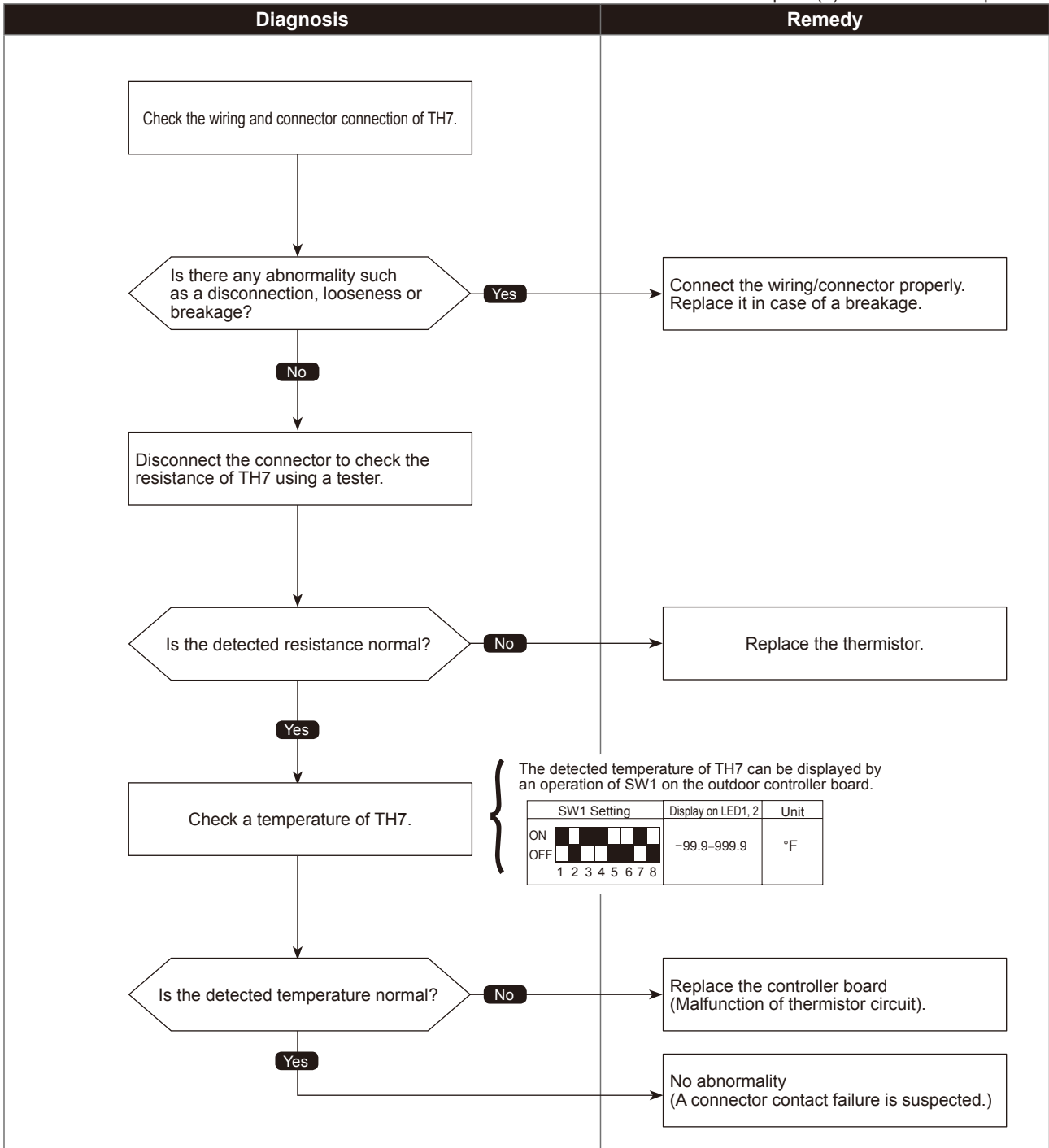

# Heat sink temperature thermistor(TH8) open/short

Abnormal points and detection methods	Causes and check points
Abnormal if TH8 detects to be open/short. Open: -16.7°F [-27°C] or less Short: 215.6°F [102°C] or more  TH8: Thermistor <Heat sink>	① Disconnection or contact failure of connectors ② Characteristic defect of thermistor ③ Defective outdoor controller board

●Diagnosis of defectives

Make sure to turn the power OFF before connecting/disconnecting any connectors, or replacing boards.

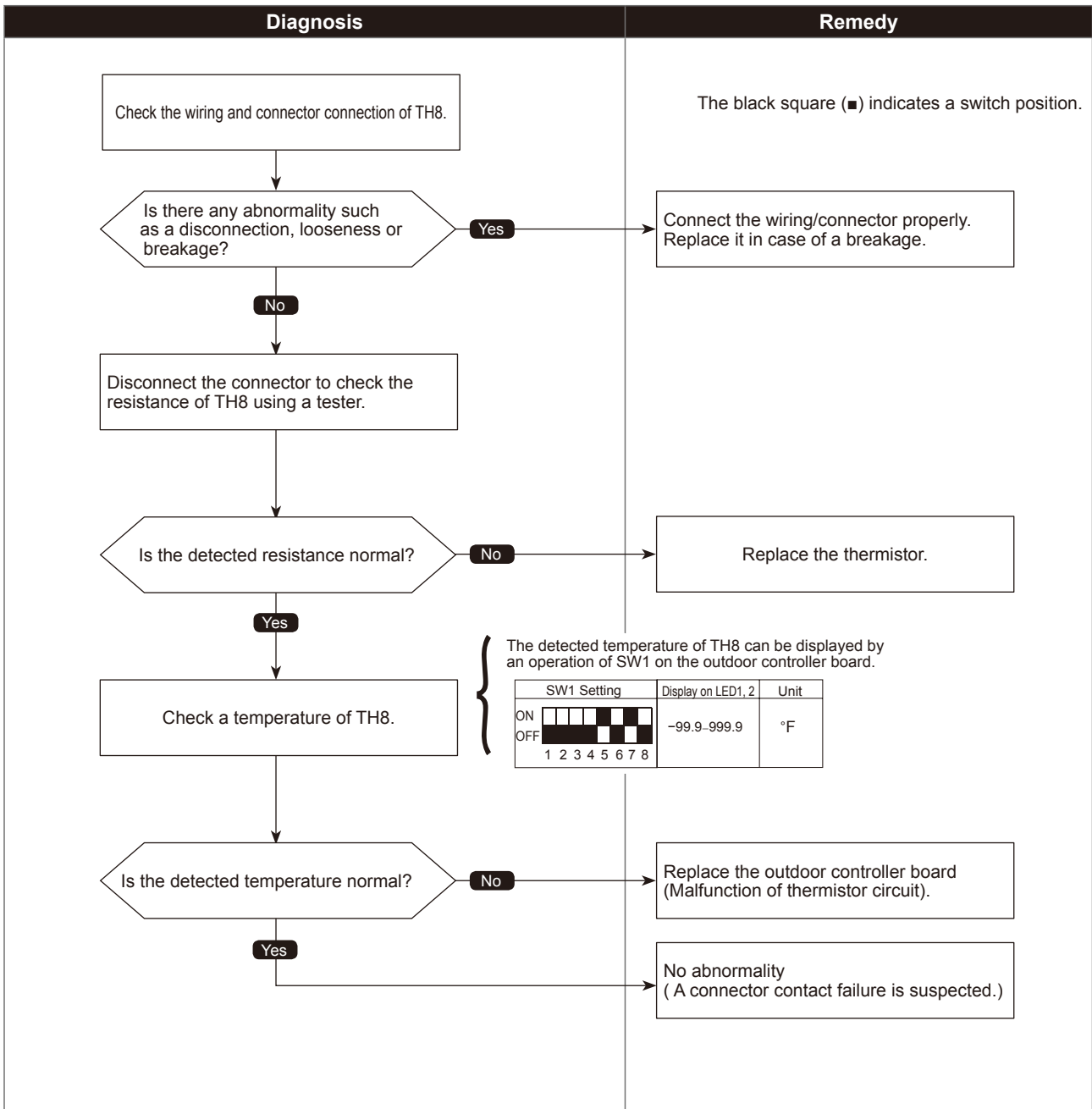

# High-pressure sensor (63HS) trouble

Abnormal points and detection methods	Causes and check points
<p>① When the detected pressure in the high-pressure sensor is 14 PSIG or less during operation, the compressor stops operation and enters into an anti-restart mode for 3 minutes.</p> <p>② When the detected pressure is 14 PSIG immediately before restarting, the compressor falls into an abnormal stop with a check code &lt;5201&gt;.</p> <p>③ For 3 minutes after compressor restarting, during defrosting operation, and for 3 minutes after returning from defrosting operation, above mentioned symptoms are not determined as abnormal.</p>	<p>① Defective high-pressure sensor</p> <p>② Decrease of internal pressure caused by gas leakage</p> <p>③ Disconnection or contact failure of connector</p> <p>④ Malfunction of input circuit on outdoor controller board</p>

●Diagnosis of defectives

Make sure to turn the power OFF before connecting/disconnecting any connectors, or replacing boards.

The black square (■) indicates a switch position.

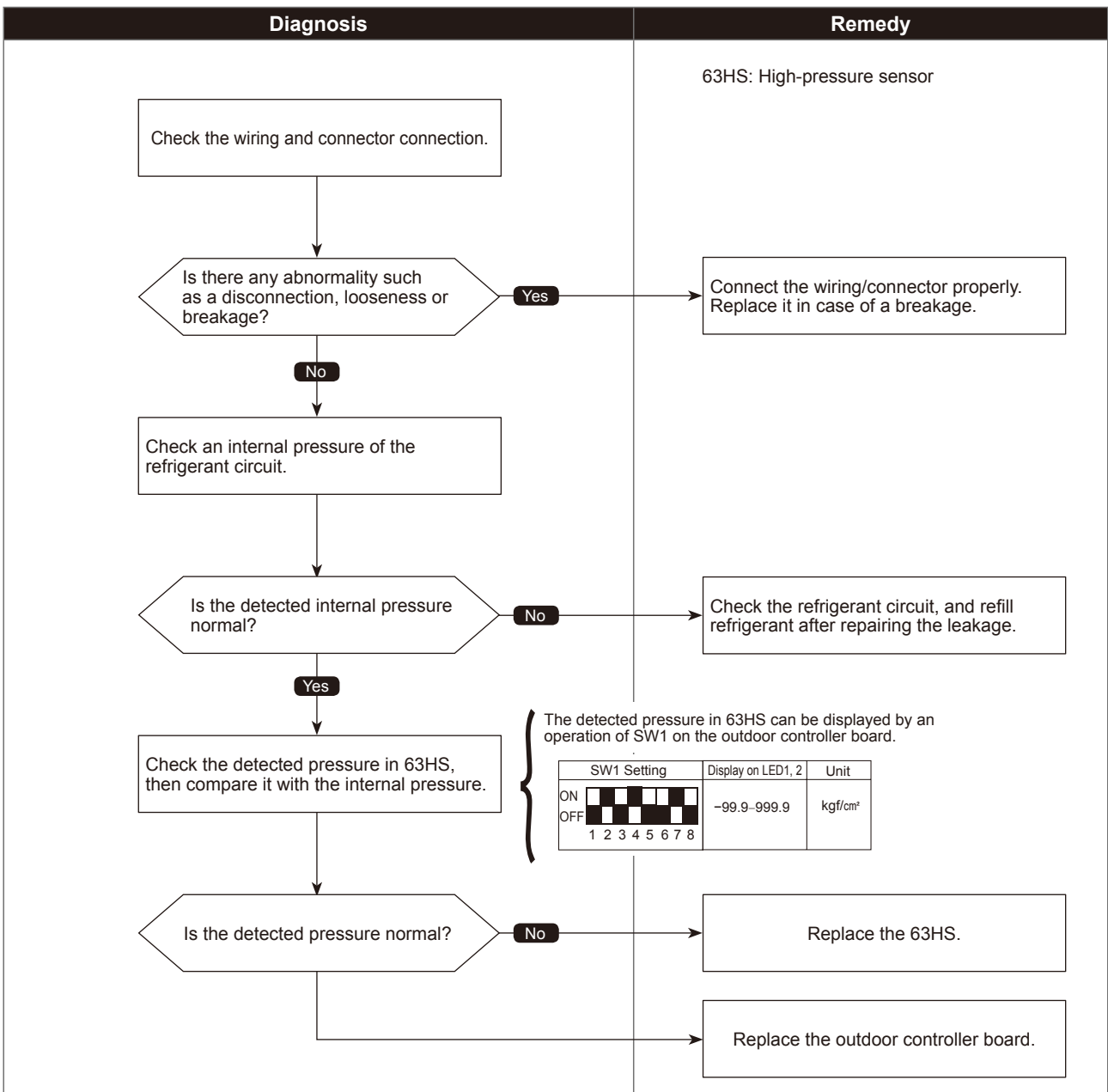

# Low-pressure sensor (63LS) trouble

Abnormal points and detection methods	Causes and check points
<p>① When the detected pressure in the low-pressure sensor is <math>-33</math> PSIG or less, or 329 PSIG or more during operation, the compressor stops operation with a check code &lt;5202&gt;.</p> <p>② For 3 minutes after compressor restarting, during defrosting operation, and for 3 minutes after returning from defrosting operation, above mentioned symptoms are not determined as abnormal.</p>	<p>① Defective low-pressure sensor</p> <p>② Decrease of internal pressure caused by gas leakage</p> <p>③ Disconnection or contact failure of connector</p> <p>④ Malfunction of input circuit on outdoor controller board</p>

● Diagnosis of defectives

Make sure to turn the power OFF before connecting/disconnecting any connectors, or replacing boards.

The black square (■) indicates a switch position.

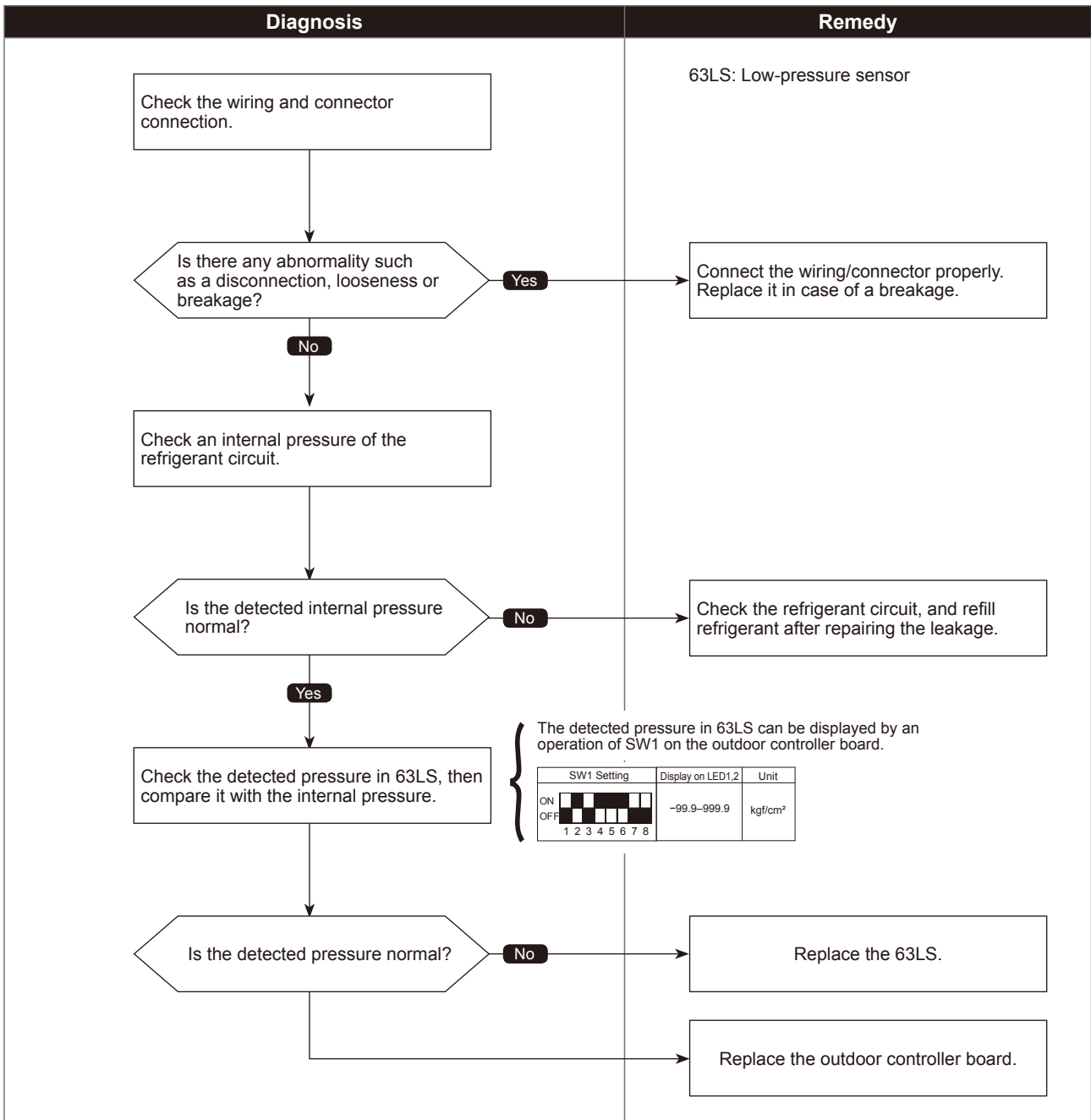

# Primary current error

Abnormal points and detection methods	Causes and check points
Abnormal if the detected current sensor input value (primary current) during compressor operation is outside the specified range.	① Decrease/trouble of power supply voltage ② Disconnection of compressor wiring ③ Input sensor trouble on outdoor power circuit board

●Diagnosis of defectives

Make sure to turn the power OFF before connecting/disconnecting any connectors, or replacing boards.

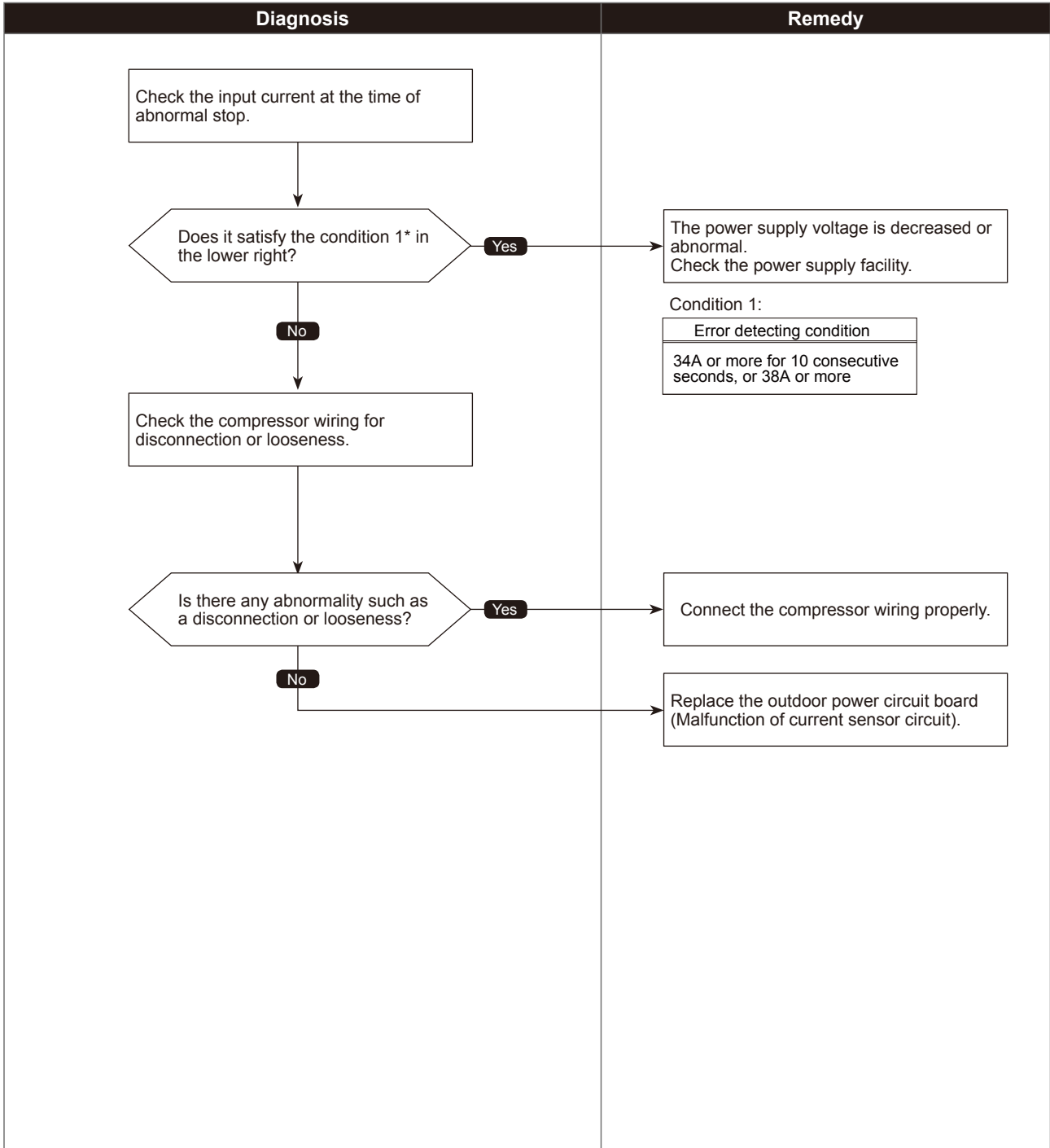

## Models equipped with the float switch

# Contact failure of drain float switch

Abnormal points and detection methods	Causes and check points
<p>&lt;Models equipped with the float switch&gt; Abnormal if the connector on the drain float switch side CN4F is detected to be disconnected.</p>	<p>① Contact failure of connector CN4F ② Defective indoor controller board</p>

● **Diagnosis of defectives**

Make sure to turn the power OFF before connecting/disconnecting any connectors, or replacing boards

Diagnosis	Remedy
<p>&lt;Models equipped with the float switch&gt;</p> <div style="border: 1px solid black; padding: 5px; margin-bottom: 10px;">           Disconnect and reconnect the connector for float switch on the indoor controller board side, then turn the power back ON.         </div> <div style="margin-bottom: 10px;"> <p style="text-align: center;">Is the check code &lt;5701&gt; still displayed?</p> <div style="display: flex; justify-content: space-around;"> <span style="border: 1px solid black; padding: 2px;">No</span> <span style="border: 1px solid black; padding: 2px;">Yes</span> </div> </div> <div style="margin-bottom: 10px;"> <div style="border: 1px solid black; padding: 5px;">             Check if it is short-circuited between pins 3-4 of the connector (CN4F) on the float switch side.           </div> </div> <div style="margin-bottom: 10px;"> <p style="text-align: center;">Is it short-circuited?</p> <div style="display: flex; justify-content: space-around;"> <span style="border: 1px solid black; padding: 2px;">No</span> <span style="border: 1px solid black; padding: 2px;">Yes</span> </div> </div>	<div style="border: 1px solid black; padding: 10px; margin-bottom: 20px;"> <p>No abnormality A connector or wiring contact failure is suspected.</p> </div> <div style="border: 1px solid black; padding: 10px; margin-bottom: 20px;"> <p>Replace the connector for float switch.</p> </div> <div style="border: 1px solid black; padding: 10px;"> <p>Replace the indoor controller board.</p> </div>

## Duplex address error

Abnormal points and detection methods	Causes and check points
Abnormal if 2 or more units with the same address are existing.	① There are 2 units or more with the same address in their controller among outdoor unit, indoor unit, Fresh Master, Lossnay or remote controller. ② Noise interference on indoor/outdoor connectors

●Diagnosis of defectives

Make sure to turn the power OFF before connecting/disconnecting any connectors, or replacing boards.

Diagnosis	Remedy
<p>Search for a unit with the same address as the source of abnormality.</p> <p>Is there any unit with the same address?</p> <p>Yes</p> <p>No</p> <p>Turn the power back ON.</p> <p>Does it operate normally?</p> <p>No</p> <p>Yes</p>	<p>Correct the address, and turn the power OFF of indoor/outdoor unit, Fresh Master or Lossnay simultaneously for 2 minutes or more, then turn the power back ON.</p> <p>Malfunction of sending/receiving circuit on indoor/outdoor unit is suspected.</p> <p>There is no abnormality on the AC unit It might be caused by an external noise, so check the transmission line to remove the factor(s).</p>

## Transmission processor H/W error

Abnormal points and detection methods	Causes and check points
Abnormal if the transmission line shows "1" although the transmission processor transmitted "0".	<ul style="list-style-type: none"> <li>① A transmitting data collision occurred because of a wiring work or polarity change has performed while the power is ON on either of the indoor/outdoor unit, Fresh Master or Lossnay.</li> <li>② Malfunction of transmitting circuit on transmission processor</li> <li>③ Noise interference on indoor/outdoor connectors</li> </ul>

## ●Diagnosis of defectives

Make sure to turn the power OFF before connecting/disconnecting any connectors, or replacing boards.

Diagnosis	Remedy
<pre> graph TD     Q1{{A wiring work was performed while the power OFF}}     Q1 -- No --&gt; R1[If the wiring work was performed while the power ON, turn the power OFF of indoor/outdoor unit, Fresh Master or Lossnay simultaneously for 2 minutes or more, then turn the power back ON.]     Q1 -- Yes --&gt; P1[Turn the power back ON.]     P1 --&gt; Q2{{Does it operate normally?}}     Q2 -- No --&gt; R2[Replace the indoor/outdoor controller board.]     Q2 -- Yes --&gt; R3[There is no abnormality on the AC unit. It might be caused by an external noise, so check the transmission line to remove the factor(s).]   </pre>	<div data-bbox="967 725 1391 861" style="border: 1px solid black; padding: 5px; margin-bottom: 10px;">       If the wiring work was performed while the power ON, turn the power OFF of indoor/outdoor unit, Fresh Master or Lossnay simultaneously for 2 minutes or more, then turn the power back ON.     </div> <div data-bbox="967 1198 1391 1287" style="border: 1px solid black; padding: 5px; margin-bottom: 10px;">       Replace the indoor/outdoor controller board.     </div> <div data-bbox="967 1334 1391 1470" style="border: 1px solid black; padding: 5px;">       There is no abnormality on the AC unit. It might be caused by an external noise, so check the transmission line to remove the factor(s).     </div>

## Transmission bus BUSY error

Abnormal points and detection methods	Causes and check points
<p>① Over error by collision Abnormal if no-transmission status caused by a transmitting data collision is consecutive for 8 to 10 minutes.</p> <p>② Abnormal if a status, that data is not allowed on the transmission line because of noise and such, is consecutive for 8 to 10 minutes</p>	<p>① The transmission processor is unable to transmit due to a short-cycle voltage such as noise is mixed on the transmission line.</p> <p>② The transmission processor is unable to transmit due to an increase of transmission data amount caused by a miswiring of the terminal block (transmission line) (TB3) and the terminal block (centralized control line) (TB7) on the outdoor unit.</p> <p>③ The share on transmission line becomes high due to a mixed transmission caused by a malfunction of repeater on the outdoor unit, which is a function to connect/disconnect transmission from/to control system and centralized control system.</p>

## ●Diagnosis of defectives

Make sure to turn the power OFF before connecting/disconnecting any connectors, or replacing boards.

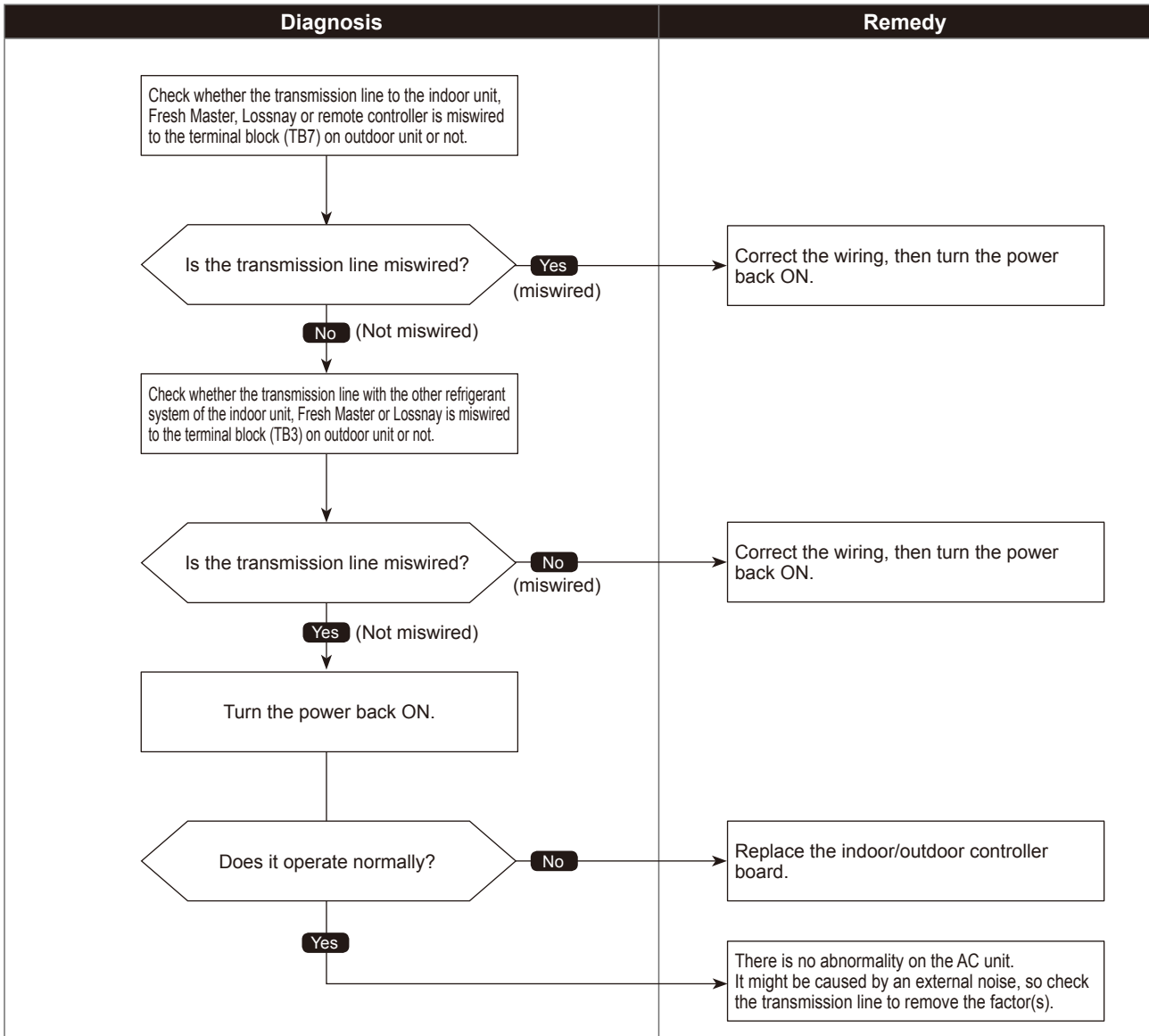

# Signal communication error with transmission processor

Abnormal points and detection methods	Causes and check points
① Abnormal if the data of unit/transmission processor were not normally transmitted. ② Abnormal if the address transmission from the unit processor was not normally transmitted.	① Accidental disturbance such as noise or lightning surge ② Hardware malfunction of transmission processor

● Diagnosis of defectives

Make sure to turn the power OFF before connecting/disconnecting any connectors, or replacing boards.

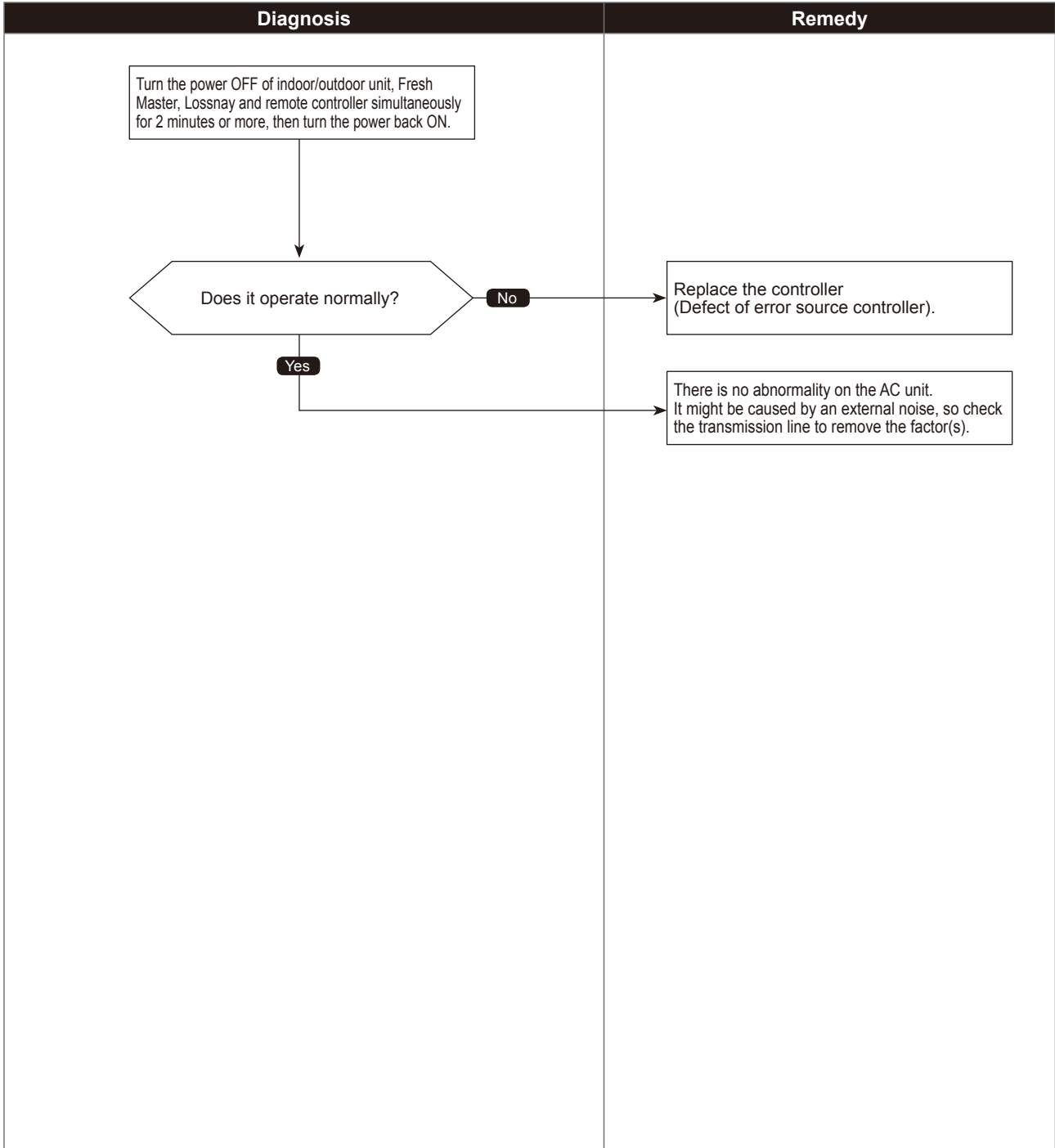

## No ACK error

Abnormal points and detection methods	Causes and check points
<p>① Represents a common error detection An abnormality detected by the sending side controller when receiving no ACK from the receiving side, though signal was once sent. The sending side searches the error in 30 seconds interval for 6 times continuously.</p>	<p>① The previous address unit does not exist since the address switch was changed while in electric continuity status. ② Decline of transmission voltage/signal caused by tolerance over on transmission line ·At the furthest end: 656 ft [200 m] ·On remote controller line: 39 ft [12 m] ③ Decline of transmission voltage/signal due to unmatched transmission line types ·Types for shield line: CVVS, CPEVS ·Line diameter: AWG16 [1.25 mm<sup>2</sup>] or more ④ Decline of transmission voltage/signal due to excessive number of connected units ⑤ Malfunction due to accidental disturbance such as noise or lightning surge ⑥ Defect of error source controller</p>
<p>② The cause of displayed address and attribute is on the outdoor unit side. An abnormality detected by the indoor unit if receiving no ACK when transmitting signal from the indoor unit to the outdoor unit.</p>	<p>① Contact failure of indoor/outdoor unit transmission line ② Disconnection of transmission connector (CN2M) on indoor unit ③ Malfunction of sending/receiving circuit on indoor/outdoor unit</p>
<p>③ The cause of displayed address and attribute is on the indoor unit side. An abnormality detected by the remote controller if receiving no ACK when sending data from the remote controller to the indoor unit.</p>	<p>① While operating with multi refrigerant system indoor units, an abnormality is detected when the indoor unit transmit signal to the remote controller during the other refrigerant-system outdoor unit is turned OFF, or within 2 minutes after it turned back ON. ② Contact failure of indoor unit or remote controller transmission line ③ Disconnection of transmission connector (CN2M) on indoor unit ④ Malfunction of sending/receiving circuit on indoor unit or remote controller</p>
<p>④ The cause of the displayed address and attribute is on the remote controller side. An abnormality detected by the indoor unit if receiving no ACK when transmitting signal from the indoor unit to the remote controller.</p>	<p>① While operating with multi refrigerant system indoor units, an abnormality is detected when the indoor unit transmit signal to the remote controller during the other refrigerant-system outdoor unit is turned OFF, or within 2 minutes after it turned back ON. ② Contact failure of indoor unit or remote controller transmission line ③ Disconnection of transmission connector (CN2M) on indoor unit ④ Malfunction of sending/receiving circuit on indoor unit or remote controller</p>

Abnormal points and detection methods	Causes and check points
<p>⑤ The cause of displayed address and attribute is on the Fresh Master side. An abnormality detected by the indoor unit if receiving no ACK when transmitting signal from the indoor unit to the Fresh Master.</p>	<p>① While the indoor unit is operating with multi refrigerant system Fresh Master, an abnormality is detected when the indoor unit transmits signal to the remote controller while the outdoor unit with the same refrigerant system as the Fresh Master is turned OFF, or within 2 minutes after it turned back ON.</p> <p>② Contact failure of indoor unit or Fresh Master transmission line</p> <p>③ Disconnection of transmission connector (CN2M) on indoor unit or Fresh Master</p> <p>④ Malfunction of sending/receiving circuit on indoor unit or Fresh Master</p>
<p>⑥ The cause of displayed address and attribute is on Lossnay side. An abnormality detected by the indoor unit if receiving no ACK when the indoor unit transmit signal to the Lossnay.</p>	<p>① An abnormality is detected when the indoor unit transmits signal to Lossnay while the Lossnay is turned OFF.</p> <p>② While the indoor unit is operating with the other refrigerant Lossnay, an abnormality is detected when the indoor unit transmits signal to the Lossnay while the outdoor unit with the same refrigerant system as the Lossnay is turned OFF, or within 2 minutes after it turned back ON.</p> <p>③ Contact failure of indoor unit or Lossnay transmission line</p> <p>④ Disconnection of transmission connector (CN2M) on indoor unit</p> <p>⑤ Malfunction of sending/receiving circuit on indoor unit or Lossnay</p>
<p>⑦ The controller of displayed address and attribute is not recognized.</p>	<p>① The previous address unit does not exist since the address switch was changed while in electric continuity status.</p> <p>② An abnormality detected at transmitting from the indoor unit since the Fresh Master/Lossnay address are changed after synchronized setting of Fresh Master/Lossnay by the remote controller.</p>

## ●Diagnosis of defectives

Make sure to turn the power OFF before connecting/disconnecting any connectors, or replacing boards.

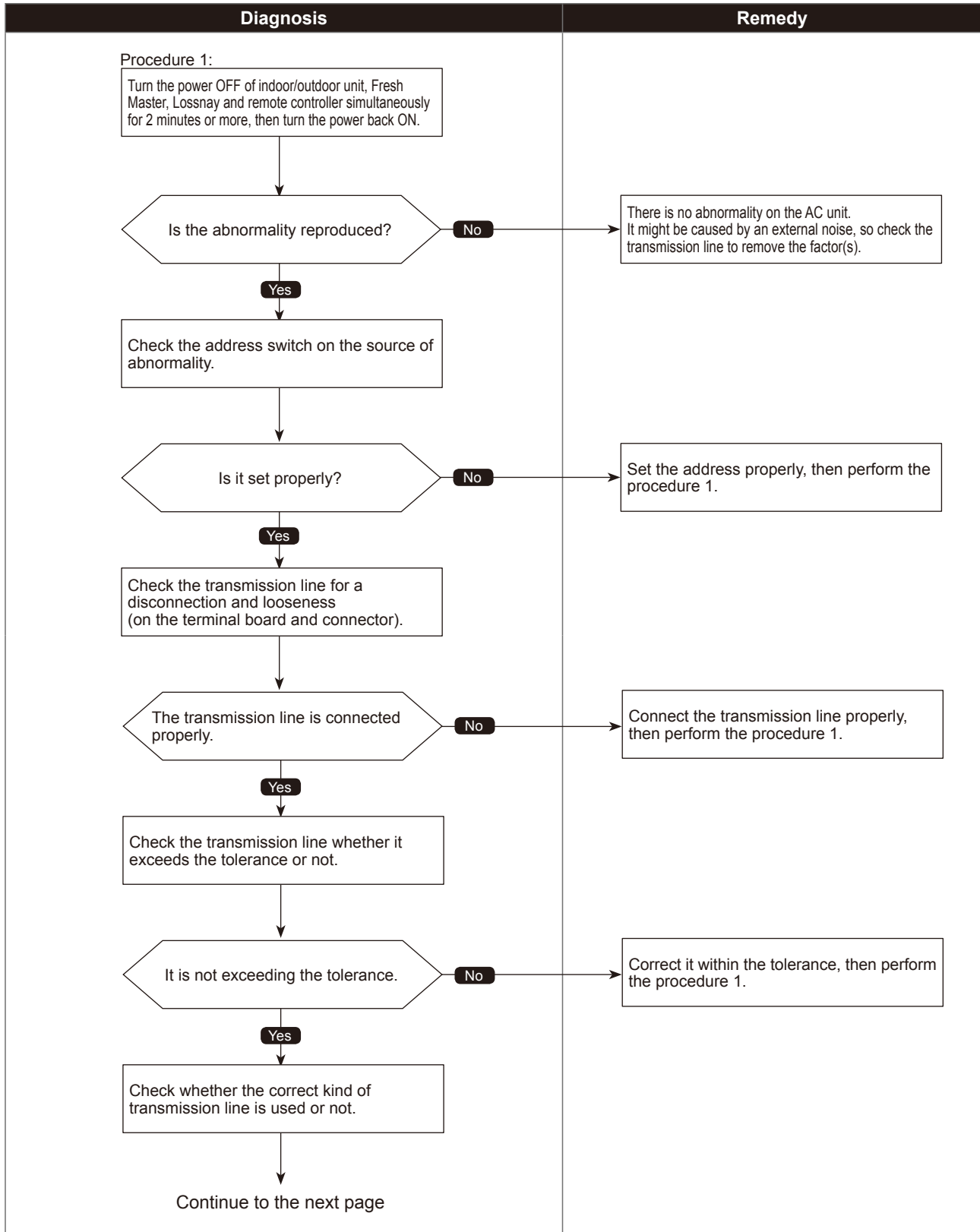

●Diagnosis of defectives

Make sure to turn the power OFF before connecting/disconnecting any connectors, or replacing boards.

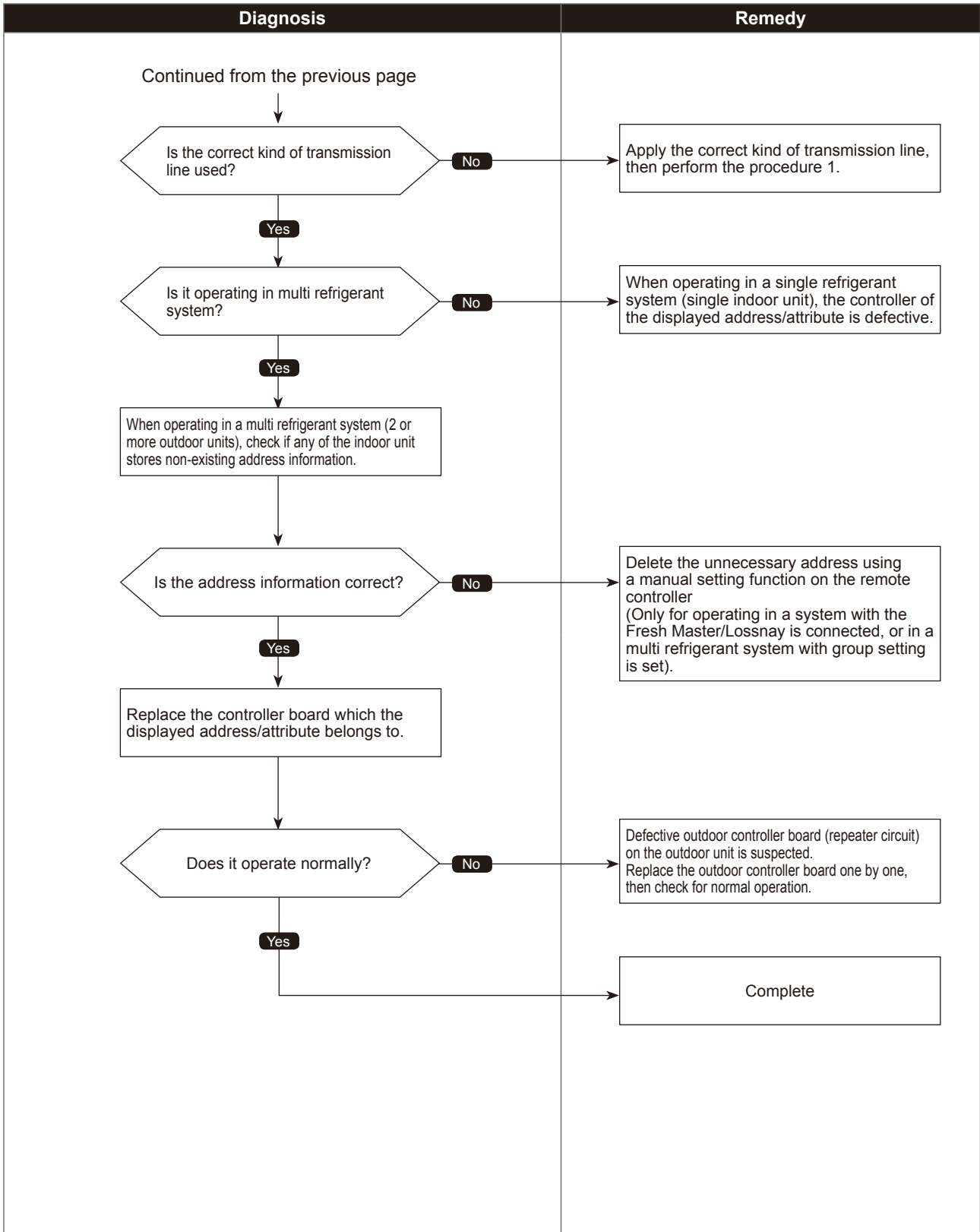

## No response frame error

Abnormal points and detection methods	Causes and check points
<p>Abnormal if receiving no response command while already received ACK. The sending side searches the error in 30 seconds interval for 6 times continuously.</p>	<ul style="list-style-type: none"> <li>① Continuous failure of transmission due to noise etc</li> <li>② Decline of transmission voltage/signal caused by tolerance over on transmission line <ul style="list-style-type: none"> <li>·At the furthest end: 656 ft [200 m]</li> <li>·On remote controller line: 39 ft [12 m]</li> </ul> </li> <li>③ Decline of transmission voltage/signal due to unmatched transmission line types <ul style="list-style-type: none"> <li>·Types for shield line: CVVS, CPEVS</li> <li>·Line diameter: AWG16 [1.25 mm<sup>2</sup>] or more</li> </ul> </li> <li>④ Accidental malfunction of error source controller</li> </ul>

## ●Diagnosis of defectives

Make sure to turn the power OFF before connecting/disconnecting any connectors, or replacing boards.

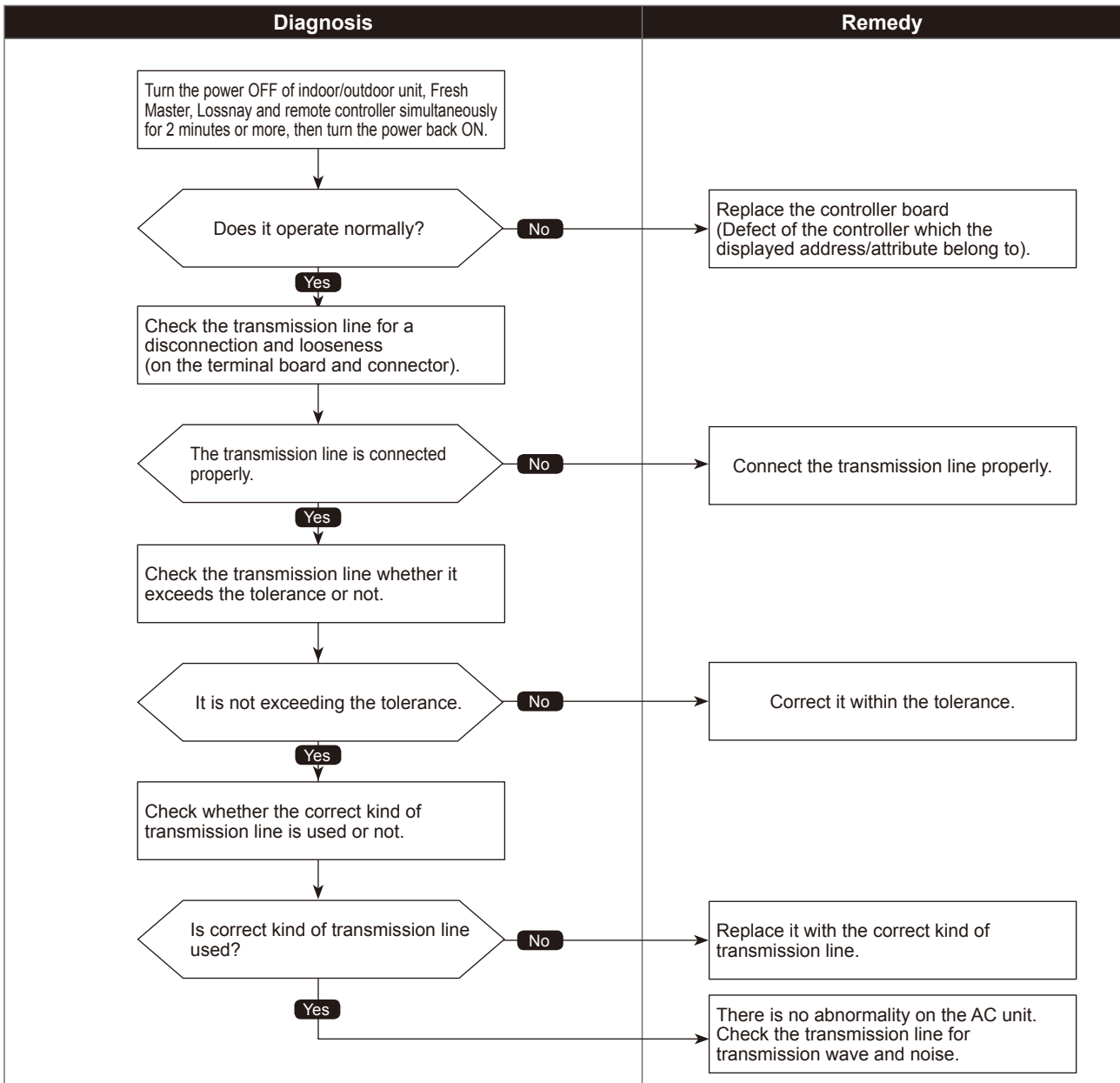

# MA communication receive error

Abnormal points and detection methods	Causes and check points
<p>Detected in remote controller or indoor unit:</p> <ul style="list-style-type: none"> <li>① When the main or sub remote controller cannot receive signal from indoor unit which has the "0" address.</li> <li>② When the sub remote controller cannot receive signal.</li> <li>③ When the indoor controller board cannot receive signal from remote controller or another indoor unit.</li> <li>④ When the indoor controller board cannot receive signal.</li> </ul>	<ul style="list-style-type: none"> <li>① Contact failure of remote controller wirings</li> <li>② Irregular Wiring (A wiring length, number of connecting remote controllers or indoor units, or a wiring thickness does not meet the conditions specified in the chapter "Electrical Work" in the indoor unit Installation Manual.)</li> <li>③ Malfunction of the remote controller sending/receiving circuit on indoor unit with the LED2 is blinking.</li> <li>④ Malfunction of the remote controller sending/receiving circuit</li> <li>⑤ Remote controller transmitting error caused by noise interference</li> </ul>

●Diagnosis of defectives

Make sure to turn the power OFF before connecting/disconnecting any connectors, or replacing boards

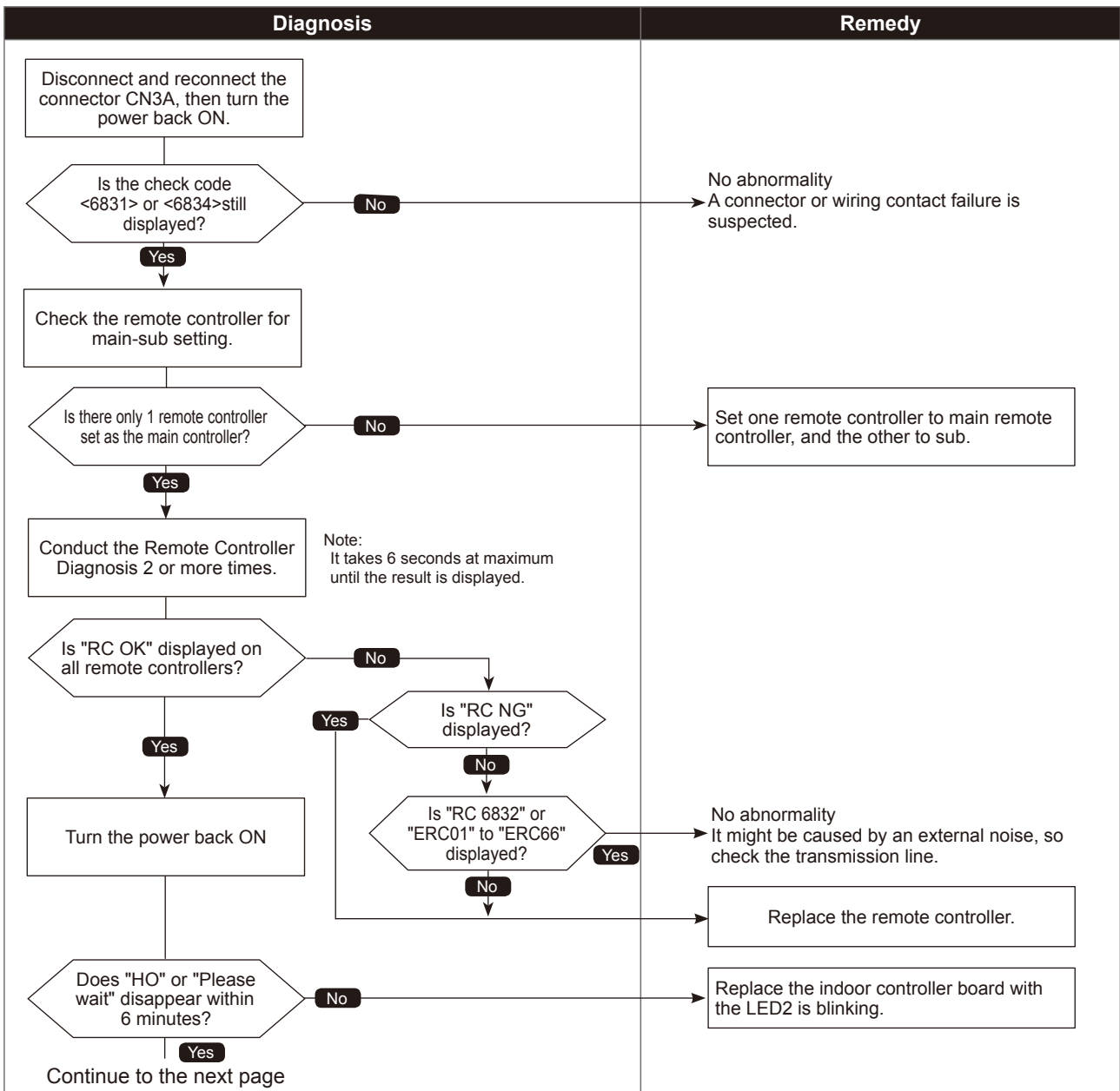

# MA communication receive error

•Diagnosis of defectives

Make sure to turn the power OFF before connecting/disconnecting any connectors, or replacing boards

Diagnosis	Remedy
<p>Continued from the previous page</p> <pre> graph TD     Start[Continued from the previous page] --&gt; Step1[Refer to the chapter "Electrical Work".]     Step1 --&gt; Decision{Is the wiring connected properly, meeting the condition?}     Decision -- No --&gt; RemedyBox[Connect the wiring properly as specified in the chapter "Electrical Work" in the indoor unit Installation Manual.]     Decision -- Yes --&gt; RemedyText[No abnormality It might be caused by an external noise, so check the transmission line to remove the factor(s).]                     </pre>	<div data-bbox="970 740 1393 832" data-label="Text"> <p>Connect the wiring properly as specified in the chapter "Electrical Work" in the indoor unit Installation Manual.</p> </div> <div data-bbox="970 853 1382 949" data-label="Text"> <p>No abnormality It might be caused by an external noise, so check the transmission line to remove the factor(s).</p> </div>

# MA communication send error

Abnormal points and detection methods	Causes and check points
Detected in remote controller or indoor unit.	① There are 2 remote controllers set as main. ② Malfunction of remote controller sending/receiving circuit ③ Malfunction of sending/receiving circuit on indoor controller board ④ Remote controller transmitting error caused by noise interference

●Diagnosis of defectives

Make sure to turn the power OFF before connecting/disconnecting any connectors, or replacing boards

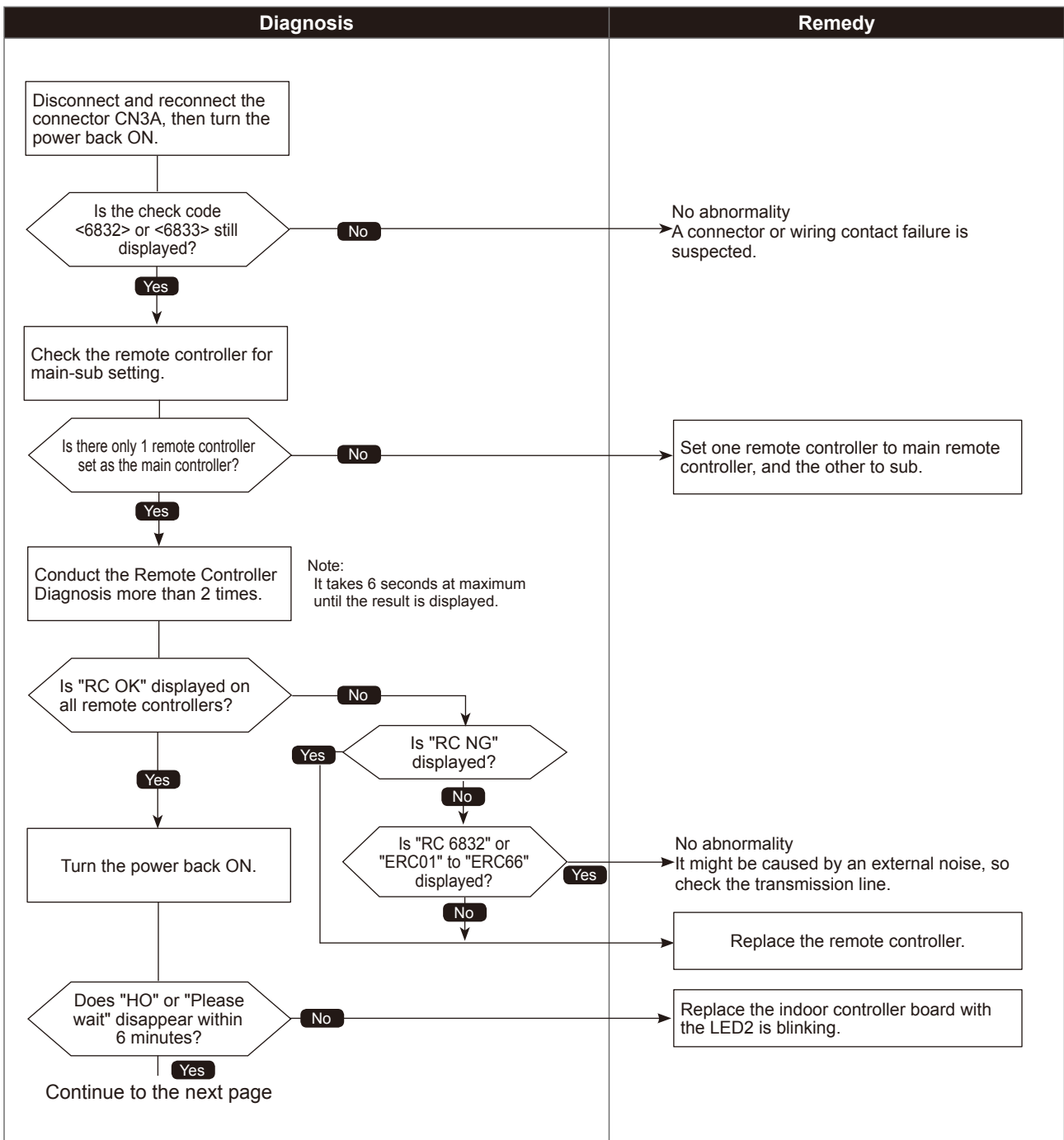

## ●Diagnosis of defectives

Make sure to turn the power OFF before connecting/disconnecting any connectors, or replacing boards

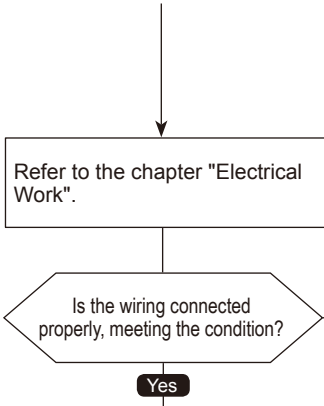
Diagnosis	Remedy
<p>Continued from the previous page</p>  <pre> graph TD     Start[Continued from the previous page] --&gt; Step1[Refer to the chapter "Electrical Work".]     Step1 --&gt; Decision{Is the wiring connected properly, meeting the condition?}     Decision -- No --&gt; Remedy1[Connect the wiring properly as specified in the chapter "Electrical Work" in the indoor unit Installation Manual.]     Decision -- Yes --&gt; Remedy2[No abnormality. It might be caused by an external noise, so check the transmission line to remove the factor(s).]   </pre>	<p>Connect the wiring properly as specified in the chapter "Electrical Work" in the indoor unit Installation Manual.</p> <p>No abnormality It might be caused by an external noise, so check the transmission line to remove the factor(s).</p>

# Total capacity error

Abnormal points and detection methods	Causes and check points
<p>When the total capacity of connected indoor units exceeds the specified capacity (130% of the outdoor unit capacity), a check code &lt;7100&gt; is displayed.</p>	<p>① The total capacity of connected indoor units exceeds the specified capacity.                      ·P36 model: up to code 26                      ·P48 model: up to code 35</p> <p>② The model name code of the outdoor unit is registered wrongly.</p>

●Diagnosis of defectives

Make sure to turn the power OFF before connecting/disconnecting any connectors, or replacing boards.

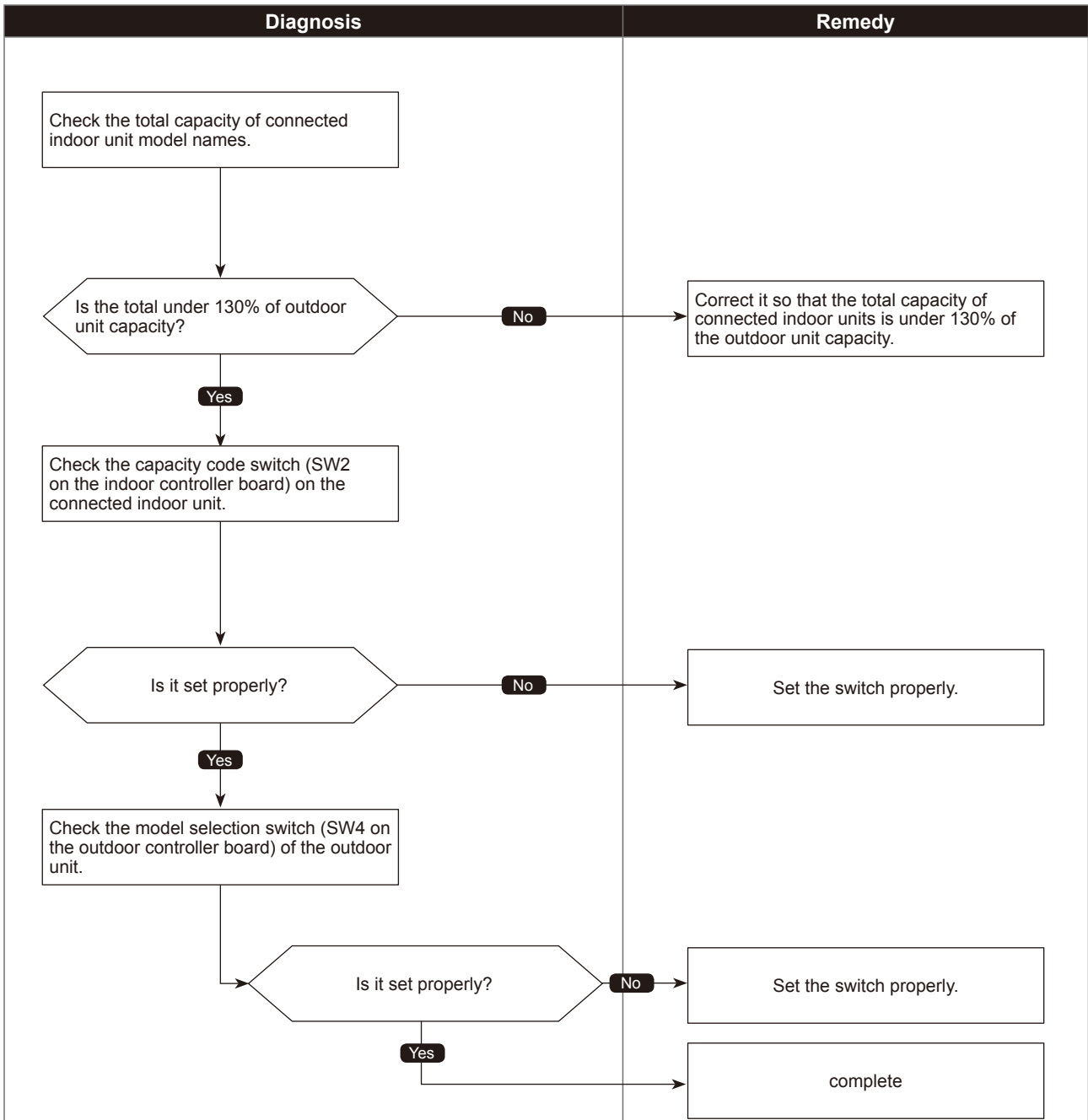

Check code

7101

# Capacity code error

Abnormal points and detection methods	Causes and check points
When a connected indoor unit is incompatible, a check code <7101> is displayed.	The model name of connected indoor unit (model code) is read as incompatible. The connectable indoor units are: ·P36 to P48 model: P06 to P54 model (code 4 to 28)

●Diagnosis of defectives

Make sure to turn the power OFF before connecting/disconnecting any connectors, or replacing boards.

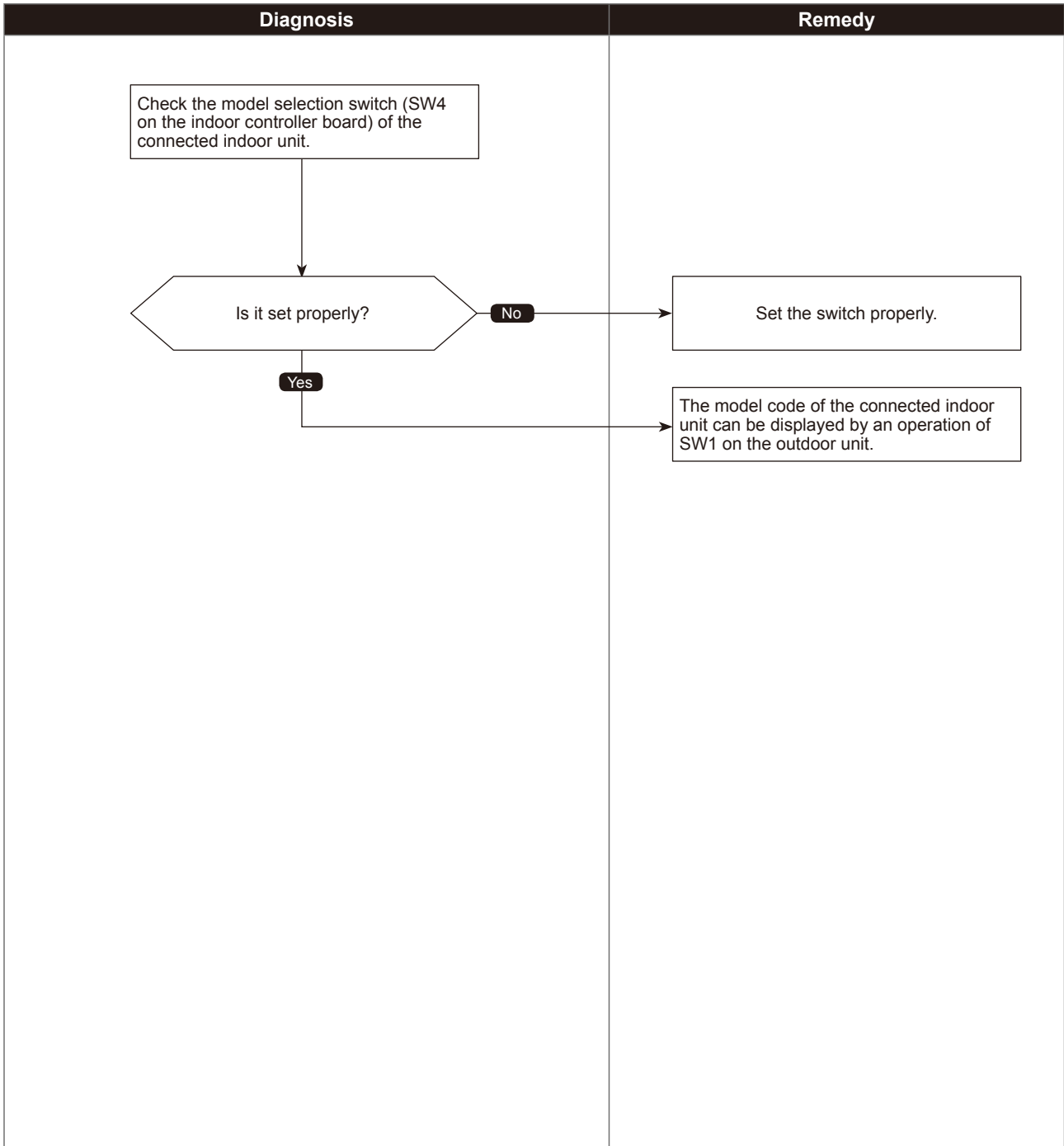

# Connecting excessive number of units

Abnormal points and detection methods	Causes and check points
<p>When the connected AC unit exceeds the limit, a check code &lt;7102&gt; is displayed.</p>	<p>Connecting more AC units than the limit Abnormal if connecting status does not comply with the following limit;</p> <ul style="list-style-type: none"> <li>① Connectable up to 12 indoor units</li> <li>② Connect at least 1 indoor unit (Abnormal if connected none)</li> <li>③ Connectable only 1 ventilation unit</li> </ul>

●Diagnosis of defectives

Make sure to turn the power OFF before connecting/disconnecting any connectors, or replacing boards.

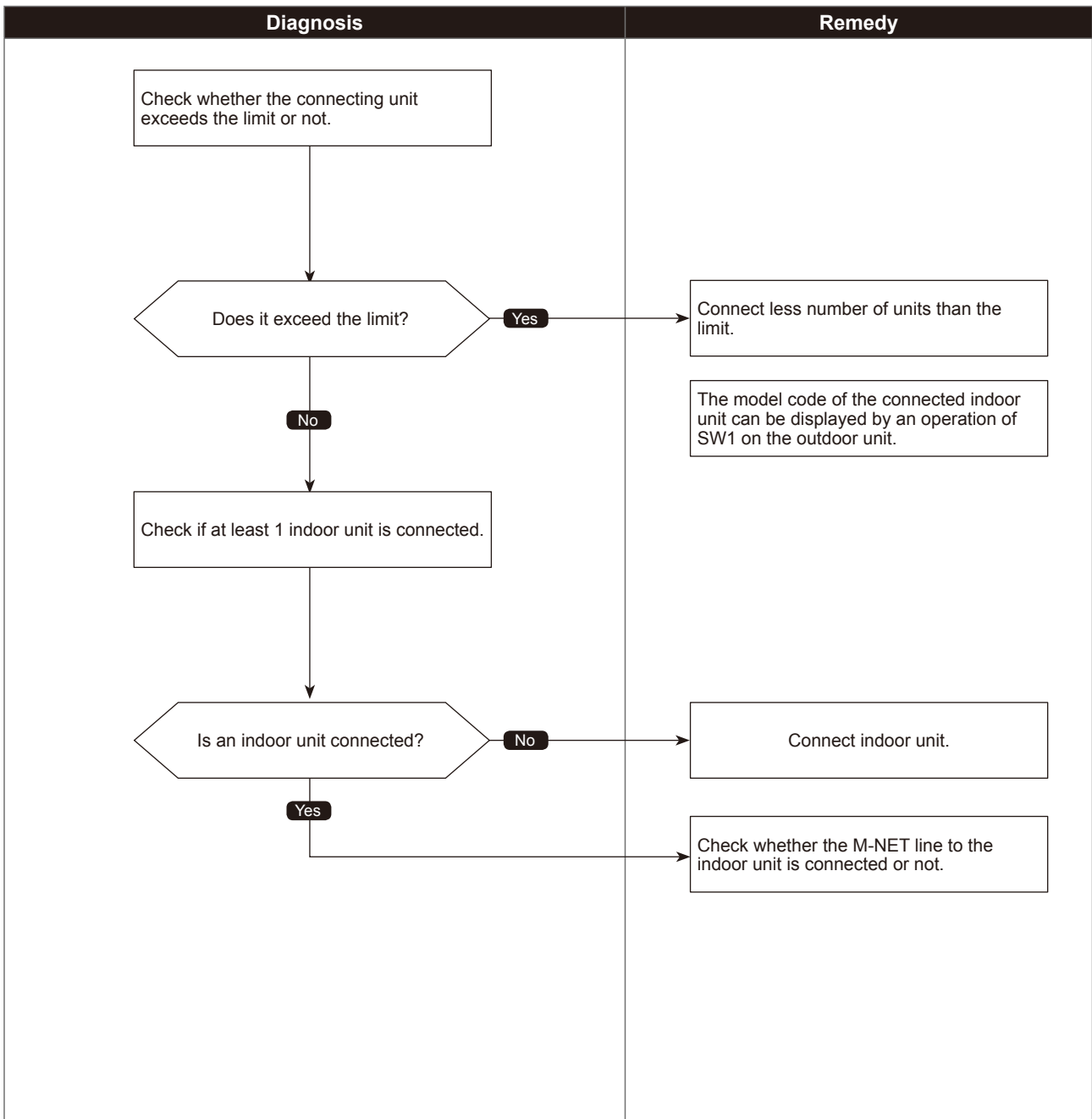

Check code

7105

# Address setting error

Abnormal points and detection methods	Causes and check points
The address setting of outdoor unit is wrong.	Wrongly set address of indoor unit The outdoor unit is not set in 000, or in the range of 51 to 100.

●Diagnosis of defectives

Make sure to turn the power OFF before connecting/disconnecting any connectors, or replacing boards.

Diagnosis	Remedy
<pre>graph TD; A[Check whether the outdoor unit address is set in 000, or in the range of 51 to 100.] --&gt; B{Is the address setting correct?}; B -- No --&gt; C[Set the address properly, then turn the power OFF of indoor/outdoor unit, Fresh Master, Lossnay and remote controller simultaneously for 2 minutes or more, and turn the power back ON.]; B -- Yes --&gt; D[Replace the outdoor controller board.];</pre>	<p>Set the address properly, then turn the power OFF of indoor/outdoor unit, Fresh Master, Lossnay and remote controller simultaneously for 2 minutes or more, and turn the power back ON.</p> <p>Replace the outdoor controller board.</p>

## 9-2. REMOTE CONTROLLER DIAGNOSIS

### · MA remote controller is equipped with the diagnosis function

If the air conditioner cannot be operated from the remote controller, diagnose the remote controller as explained below.

- ① First, check that the power-on indicator is lit.  
If the correct voltage (12 V DC) is not supplied to the remote controller, the indicator will not light.  
If this occurs, check the remote controller's wiring and the indoor unit.

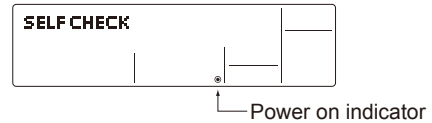

- ② Switch to the remote controller self-diagnosis mode.  
Press the **CHECK** button for 5 seconds or more. The display content will change as shown below.

Press the **FILTER** button to start self-diagnosis.

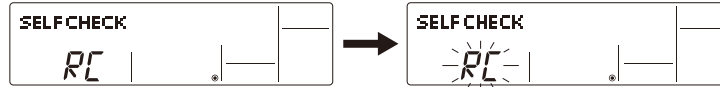

- ③ Remote controller self-diagnosis result

[When the remote controller is functioning correctly]



Check for other possible causes, as there is no problem with the remote controller.

[When the remote controller malfunctions]  
(Error display 1) "NG" blinks. → The remote controller's transmitting-receiving circuit is defective.



The remote controller must be replaced with a new one.

[Where the remote controller is not defective, but cannot be operated.]  
(Error display 2) [E3], [6833] or [6832] blinks. → Transmission is not possible.



There might be noise or interference on the transmission path, or the indoor unit or other remote controllers are defective. Check the transmission path and other controllers.

(Error display 3) "ERC" and the number of data errors are displayed.  
→ Data error has occurred.

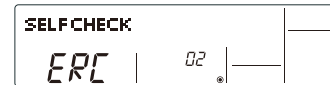

The number of data errors is the difference between the number of bits sent from the remote controller and the number actually transmitted through the transmission path. If such a problem is occurring, the transmitted data is affected by noise, etc. Check the transmission path.

🔍 When the number of data errors is "02":  
Transmission data from remote controller   
Transmission data on transmission path

- ④ To cancel remote controller diagnosis

Press the **CHECK** button for 5 seconds or more. Remote controller diagnosis will be cancelled, "PLEASE WAIT" and operation lamp will blink. After approximately 30 seconds, the state in effect before the diagnosis will be restored.

## 9-3. REMOTE CONTROLLER TROUBLE

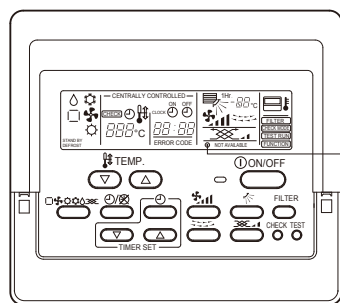

“●” indicator: Appears when current is carried.

(M-NET Remote controller)

### (1) For M-NET remote controller systems

Symptom or inspection code	Cause	Inspection method and solution
Though the content of operation is displayed on the remote controller, some indoor units do not operate.	<ul style="list-style-type: none"> <li>The power supply of the indoor unit is not on.</li> <li>The address of the indoor units in same group or the remote controller is not set correctly.</li> <li>The group setting between outdoor units is not registered to the remote controller.</li> <li>The fuse on the indoor unit controller board is blown.</li> </ul>	<ul style="list-style-type: none"> <li>Check the part where the abnormality occurs.</li> <li>① The entire system</li> <li>② In the entire refrigerant system</li> <li>③ In same group only</li> <li>④ 1 indoor unit only</li> </ul>
Though the indoor unit operates, the display of the remote controller goes out soon.	<ul style="list-style-type: none"> <li>The power supply of the indoor unit is not on.</li> <li>The fuse on the indoor unit controller board is blown.</li> </ul>	<p>&lt;In case of the entire system or in the entire refrigerant system&gt;</p> <ul style="list-style-type: none"> <li>Check the self-diagnosis LED of the outdoor unit.</li> <li>Check the items shown in the left that are related to the outdoor unit.</li> </ul>
(●) is not displayed on the remote controller. (M-NET remote controller is not fed.)	<ul style="list-style-type: none"> <li>The power supply of the outdoor unit is not on.</li> <li>The connector of transmission outdoor power board is not connected.</li> <li>The number of connected indoor unit in the refrigeration system is over the limit or the number of connected remote controller is over the limit.</li> <li>M-NET remote controller is connected to MA remote controller cable.</li> <li>The transmission line of the indoor/outdoor unit is shorted or down.</li> <li>M-NET remote controller cable is shorted or down.</li> <li>Transmission outdoor power board failure</li> </ul>	<p>&lt;In case of in same group only or 1 indoor unit only&gt;</p> <ul style="list-style-type: none"> <li>Check the items shown in the left that are related to the indoor unit.</li> </ul>
"HO" keeps being displayed or it is displayed periodically. ("HO" is usually displayed about 3 minutes after the power supply of the outdoor unit is on.)	<ul style="list-style-type: none"> <li>The power supply for the feeding expansion unit for the transmission line is not on.</li> <li>The address of the outdoor unit remains "00".</li> <li>The address of the indoor unit or the remote controller is not set correctly.</li> <li>MA remote controller is connected to the transmission line of the indoor/outdoor unit.</li> </ul>	
The remote controller does not operate though (●) is displayed.	<ul style="list-style-type: none"> <li>The transmission line of the indoor/outdoor unit is connected to TB15.</li> <li>The transmission line of the indoor/outdoor unit is shorted, down or badly contacted.</li> </ul>	

### (2) For MA remote controller systems

Symptom or inspection code	Cause	Inspection method and solution
Though the content of operation is displayed on the remote controller, some indoor units do not operate.	<ul style="list-style-type: none"> <li>The power supply of the indoor unit is not on.</li> <li>Wiring between indoor units in same group is not finished.</li> <li>The indoor unit and Slim model are connected to same group.</li> <li>The fuse on the indoor unit controller board is blown.</li> </ul>	<ul style="list-style-type: none"> <li>Check the part where the abnormality occurs.</li> <li>① The entire system</li> <li>② In the entire refrigerant system</li> <li>③ In same group only</li> <li>④ 1 indoor unit only</li> </ul>
Though the indoor unit operates, the display of the remote controller goes out soon.	<ul style="list-style-type: none"> <li>The power supply of the indoor unit (Master) is not on.</li> <li>In case of connecting the system controller, the setting of the system controller does not correspond to that of MA remote controller.</li> <li>The fuse on the indoor unit (Master) controller board is blown.</li> </ul>	<p>&lt;In case of the entire system or in the entire refrigerant system&gt;</p> <ul style="list-style-type: none"> <li>Check the self-diagnosis LED of the outdoor unit.</li> <li>Check the items shown in the left that are related to the outdoor unit.</li> </ul>
(●) is not displayed on the remote controller. (MA remote controller is not fed.)	<p>The remote controller is not fed until the power supply of both indoor unit and outdoor unit is on and the start-up of both units is finished normally.</p> <ul style="list-style-type: none"> <li>The power supply of the indoor unit is not on.</li> <li>The power supply of the outdoor unit is not on.</li> <li>The number of connected remote controller is over the limit (Maximum: 2 units) or the number of connected indoor unit that is over the limit (Maximum: 16 units).</li> <li>The address of the indoor unit is "00" and the address for the outdoor unit is the one other than "00".</li> <li>The transmission line of the indoor/outdoor unit is connected to TB15.</li> <li>MA remote controller is connected to the transmission line of the indoor/outdoor unit.</li> <li>The remote controller cable is shorted or down.</li> <li>The power supply cable or the transmission line is shorted or down.</li> <li>The fuse on the indoor unit controller board is blown.</li> </ul>	<p>&lt;In case of in same group only or 1 indoor unit only&gt;</p> <ul style="list-style-type: none"> <li>Check the items shown in the left that are related to the indoor unit.</li> </ul>
"PLEASE WAIT" keeps being displayed or it is displayed periodically. ("PLEASE WAIT" is usually displayed about 3 minutes after the power supply of the outdoor unit is on.)	<ul style="list-style-type: none"> <li>The power supply of the outdoor unit is not on.</li> <li>The power supply of the feeding expansion unit for the transmission line is not on.</li> <li>The setting of MA remote controller is not main remote controller, but sub-remote controller.</li> <li>MA remote controller is connected to the transmission line of the indoor/outdoor unit.</li> </ul>	
The remote controller does not operate though (●) is displayed.	<ul style="list-style-type: none"> <li>The power supply of the indoor unit (Master) is not on.</li> <li>The transmission line of the indoor/outdoor unit is connected to TB15.</li> <li>The transmission line of the indoor/outdoor unit is shorted, down or badly contacted.</li> <li>The fuse on the indoor unit controller board is blown.</li> </ul>	

#### 9-4. THE FOLLOWING SYMPTOM DO NOT REPRESENT TROUBLE (EMERGENCY)

Symptom	Display of remote controller	CAUSE
Even the cooling (heating) operation selection button is pressed, the indoor unit cannot be operated.	"Cooling (Heating)" blinks	The indoor unit cannot cool (heat) if other indoor units are heating (cooling).
The auto vane runs freely.	Normal display	Because of the control operation of auto vane, it may change over to horizontal blow automatically from the downward blow in cooling in cause the downward blow operation has been continued for one hour. At defrosting in heating, hot adjusting and thermostat OFF, it automatically changes over to horizontal blow.
Fan setting changes during heating.	Normal display	Ultra-low speed operation is commenced at thermostat OFF. Light air automatically change over to set value by time or piping temperature at thermostat ON.
Fan stops during heating operation.	"Defrost ☆"	The fan is to stop during defrosting.
Fan does not stop while operation has been stopped.	Light out	Fan is to run for 1 minute after stopping to exhaust residual heat (only in heating).
No setting of fan while start SW has been turned on.	STAND BY ☆	Ultra-low speed operation for 5 minutes after SW ON or until piping temperature becomes 35°C. There low speed operate for 2 minutes, and then set notch is commenced. (Hot adjust control)
Indoor unit remote controller shows "HO" or "PLEASE WAIT" indicator for about 2 minutes when turning ON power supply.	"HO" blinks "PLEASE WAIT" blinks	System is being driven. Operate remote controller again after "HO" or "PLEASE WAIT" disappears.
Drain pump does not stop while unit has been stopped.	Light out	After a stop of cooling operation, unit continues to operate drain pump for 3 minutes and then stops it.
Drain pump continues to operate while unit has been stopped.	—	Unit continues to operate drain pump if drainage is generated, even during a stop.
The compressor that is running soon after powered on is slow to speed up.	—	The rate of speed-up is kept at 2 Hz/min. during 4 hours after powered on.  This can prevent a compressor failure that occurs when a non-energized compressor speeds up rapidly with refrigerant collected in the compressor.























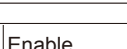

## 9-5. INTERNAL SWITCH FUNCTION TABLE

PUMY-P36NHMU(-BS)  
PUMY-P48NHMU(-BS)  
PUMY-P48NHMU<sub>2</sub>(-BS)

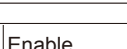
PUMY-P36NHMUR1(-BS)  
PUMY-P48NHMU<sub>1</sub>(-BS)  
PUMY-P48NHMUR3(-BS)

PUMY-P36NHMUR4(-BS)  
PUMY-P48NHMUR4(-BS)

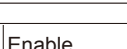
The black square (■) indicates a switch position.

Switch	Step	Function	Operation in Each Switch Setting			Remarks						
			ON	OFF	When to Set							
SW U1 1s digit  SW U2 10s digit	Rotary switch	 SWU2 (10s digit)  SWU1 (1s digit)			Before turning the power on	<Initial settings>  SWU2 (10s digit)  SWU1 (1s digit)						
SW1 Digital Display Switch	1-8	ON  OFF 			Can be set either during operation or not	<Initial settings> ON  OFF 						
SW2 Function Switch	1	Selects operating system startup*1	With centralized controller	Without centralized controller	Before turning the power on	<Initial settings> ON  OFF 						
	2	Connection Information Clear Switch	Clear	Do not clear								
	3	Abnormal data clear switch input	Clear abnormal data	Normal	OFF to ON any time after the power is turned on							
	4	Pump down	Run adjustment mode	Normal	During compressor running							
	5	Auto change over from Remote controller	Enable	Disable	Before turning the power on							
	6	—	—	—	—							
SW3 Test run	1	ON/OFF from outdoor unit	ON	OFF	Always	<Initial settings> ON  OFF 						
	2	Mode setting	Heating	Cooling								
SW4 Model Switch	1-6	<MODEL SELECT>*2 <table border="1" data-bbox="453 1029 794 1193"> <thead> <tr> <th>MODELS</th> <th>SW4</th> </tr> </thead> <tbody> <tr> <td>PUMY-P36NHMU</td> <td>ON  OFF </td> </tr> <tr> <td>PUMY-P48NHMU</td> <td>ON  OFF </td> </tr> </tbody> </table>		MODELS	SW4	PUMY-P36NHMU	ON  OFF 	PUMY-P48NHMU	ON  OFF 		Before the power is turned on	<Initial settings> Set for each capacity.
MODELS	SW4											
PUMY-P36NHMU	ON  OFF 											
PUMY-P48NHMU	ON  OFF 											
SW5 Function switch	1	Pressure limitation value change	Enable	Normal	Can be set when off or during operation  OFF to ON during compressor running  Can be set when off or during operation	<Initial settings> ON  OFF						
	2	Change the indoor unit's LEV opening at start	Enable	Normal								
	3	Fixing the indoor units linear expansion valve opening	Fix	Normal								
	4	Fix the operation frequency	Fix	Normal								
	5	Change the indoor unit's LEV opening at defrost	Enable	Normal								
	6	Switching the target sub cool	Enable	Normal								
	7	During the FAN or COOL mode, and thermo-OFF or OFF in heating operation, set the opening of linear expansion valve on indoor unit *3	Active	Inactive								
	8	During the FAN or COOL mode, and thermo-OFF in heating operation, set the opening of linear expansion valve on indoor unit *4	Active	Inactive								

\*1 SW2-1 must be turned ON if a central controller is connected to the system. An example of this would be a TC-24, EW-50A, AG150, AE50 or AE200. If SW2-1 is not turned on, while using a central controller, in rare circumstances problems may be encountered such as indoor units not responding to group commands. Therefore, turning SW2-1 ON is recommended if a central controller is used.

\*2 This model switching is not available for PUMY-P48NHMU(-BS) since it does not have the auxiliary heating function.

DIP SW4-4 for auxiliary heating control : Set DIP SW4-4 always.

DIP SW4-4 OFF : Auxiliary heating function (Initial setting) is disabled.

DIP SW4-4 ON : Auxiliary heating function is enabled.

\*3 SW5-7 Refrigerant shortage amount is measured during heating operation.(Refrigerant piping is long, etc.)

\*4 SW5-8 Countermeasure against room temperature rise for indoor unit in FAN, COOL, and thermo-OFF (heating) mode.

The black square (■) indicates a switch position.

	Switch	Step	Function	Operation in Each Switch Setting			Remarks																
				ON	OFF	When to Set																	
Outdoor unit	SW6 Function switch	1	—	—	—	—	<Initial settings>  ON <table border="1" style="display: inline-table; vertical-align: middle;"><tr><td> </td><td> </td><td> </td><td> </td><td> </td><td> </td><td> </td><td> </td></tr></table> OFF <table border="1" style="display: inline-table; vertical-align: middle;"><tr><td> </td><td> </td><td> </td><td> </td><td> </td><td> </td><td> </td><td> </td></tr></table> 1 2 3 4 5 6 7 8																
		2	Switch of current limitation reading in a different way	Enable	Normal	Before turning the power on																	
		3	—	—	—	—																	
		4	Restriction of maximum frequency	Enable	Normal	Can be set when off or during operation																	
		5	Ignore refrigerant filling abnormality	Enable	Normal																		
		6	Switching the target discharge pressure (Pdm)	Enable	Normal																		
	7	Switching (1) the target evaporation temperature (ETm)	Enable	Normal																			
	8	Switching (2) the target evaporation temperature (ETm)	Enable	Normal																			
	SW7 Function switch	1	Ignore current sensor abnormality	Enable	Normal	After turning the power on	<Initial settings>  ON <table border="1" style="display: inline-table; vertical-align: middle;"><tr><td> </td><td> </td><td> </td><td> </td><td> </td><td> </td></tr></table> OFF <table border="1" style="display: inline-table; vertical-align: middle;"><tr><td> </td><td> </td><td> </td><td> </td><td> </td><td> </td></tr></table> 1 2 3 4 5 6																
		2	—	—	—	—																	
		3	—	—	—																		
		4	—	—	—																		
	5	Simultaneous operation for cooling and heating *5	Enable	Disable	Always																		
	6	Forced defrost	Forced defrost	Normal	During compressor running in heating mode																		
	SW8 Function switch	1	Silent mode/Demand Control Selection (see "9-6. OUTDOOR UNIT INPUT/OUTPUT CONNECTOR". )	Demand Control	Silent mode	Can be set when off or during operation	<Initial settings> ON <table border="1" style="display: inline-table; vertical-align: middle;"><tr><td> </td><td> </td></tr></table> OFF <table border="1" style="display: inline-table; vertical-align: middle;"><tr><td> </td><td> </td></tr></table> 1 2																
	2	Change of defrosting control	Enable (For high humidity)	Normal																			

\*5 This function is available only for PUMY-P36/48NHMUR4 models.

## 9-6. OUTDOOR UNIT INPUT/OUTPUT CONNECTOR

### • State (CN51)

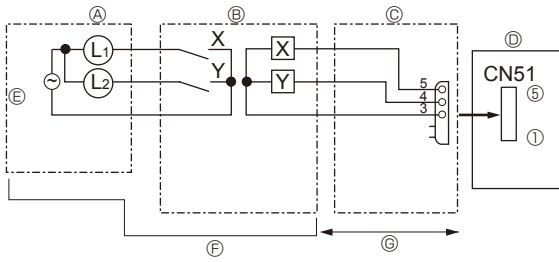

- Ⓐ Distant control board
- Ⓑ Relay circuit
- Ⓒ External output adapter (PAC-SA88HA-E)
- Ⓓ Outdoor unit control board
- Ⓔ Lamp power supply
- Ⓕ Procure locally
- Ⓖ Maximum 33 ft [10 m]

L<sub>1</sub> : Error display lamp  
 L<sub>2</sub> : Compressor operation lamp  
 X, Y : Relay (Coil standard of 0.9W or less for 12 V DC)  
 X, Y : Relay (DC1mA)

### • Auto change over (CN3N)

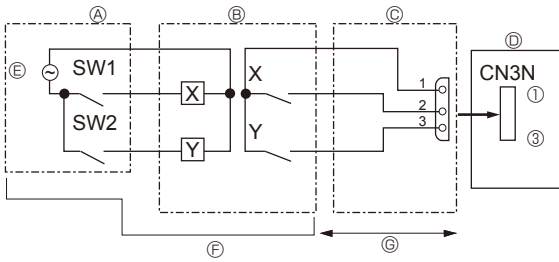

- Ⓐ Remote control panel
- Ⓑ Relay circuit
- Ⓒ External input adapter (PAC-SC36NA)
- Ⓓ Outdoor unit control board
- Ⓔ Relay power supply
- Ⓕ Procure locally
- Ⓖ Maximum 33 ft [10 m]

	ON	OFF
SW1	Heating	Cooling
SW2	Validity of SW1	Invalidity of SW1

### • Silent Mode/Demand Control (CN3D)

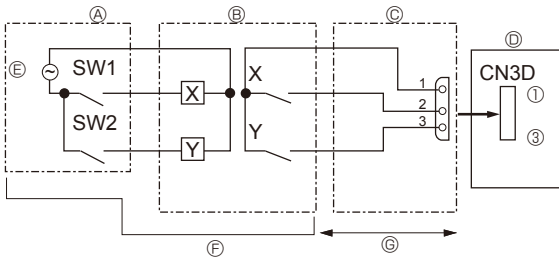

- Ⓐ Remote control panel
- Ⓑ Relay circuit
- Ⓒ External input adapter (PAC-SC36NA)
- Ⓓ Outdoor unit control board
- Ⓔ Relay power supply
- Ⓕ Procure locally
- Ⓖ Maximum 33 ft [10 m]

The silent mode and the demand control are selected by switching the DIP switch 8-1 on outdoor controller board. It is possible to set it to the following power consumption (compared with ratings) by setting SW1,2

	Outdoor controller board DIP SW8-1	SW1	SW2	Function
Silent mode	OFF	ON	—	Silent mode operation
Demand control	ON	OFF	OFF	100% (Normal)
		ON	OFF	75%
		ON	ON	50%
		OFF	ON	0% (Stop)

## 9-7. HOW TO CHECK THE PARTS

PUMY-P36NHMU(-BS)

PUMY-P36NHMUR1(-BS)

PUMY-P36NHMUR4(-BS)



PUMY-P48NHMU(-BS)

PUMY-P48NHMU<sub>1</sub>(-BS)

PUMY-P48NHMU<sub>2</sub>(-BS)

PUMY-P48NHMUR3(-BS)

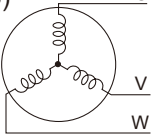
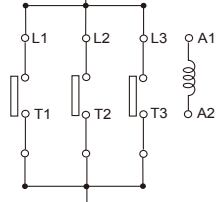
PUMY-P48NHMUR4(-BS)

Parts name	Check points														
Thermistor (TH3) <Outdoor pipe> Thermistor (TH4) <Discharge/Compressor> Thermistor (TH6) <Low pressure saturated temperature> Thermistor (TH7) <Outdoor> Thermistor (TH8) <Heat sink>	Disconnect the connector then measure the resistance with a tester. (At the ambient temperature 50 to 86°F [10 to 30°C]) <table border="1" style="margin-top: 10px;"> <thead> <tr> <th></th> <th>Normal</th> <th>Abnormal</th> </tr> </thead> <tbody> <tr> <td>TH4</td> <td>160 to 410 kΩ</td> <td rowspan="4">Open or short</td> </tr> <tr> <td>TH3</td> <td rowspan="2">4.3 to 9.6 kΩ</td> </tr> <tr> <td>TH6</td> </tr> <tr> <td>TH7</td> </tr> <tr> <td>TH8</td> <td>39 to 105 kΩ</td> <td></td> </tr> </tbody> </table>			Normal	Abnormal	TH4	160 to 410 kΩ	Open or short	TH3	4.3 to 9.6 kΩ	TH6	TH7	TH8	39 to 105 kΩ	
	Normal	Abnormal													
TH4	160 to 410 kΩ	Open or short													
TH3	4.3 to 9.6 kΩ														
TH6															
TH7															
TH8	39 to 105 kΩ														
Fan motor(MF1,MF2)	Refer to the next page.														
Solenoid valve coil <4-way valve> (21S4)	Measure the resistance between the terminals with a tester. (At the ambient temperature 68°F [20°C]) <table border="1" style="margin-top: 10px;"> <thead> <tr> <th>Normal</th> <th>Abnormal</th> </tr> </thead> <tbody> <tr> <td>1190 ± 100 Ω</td> <td>Open or short</td> </tr> </tbody> </table>		Normal	Abnormal	1190 ± 100 Ω	Open or short									
Normal	Abnormal														
1190 ± 100 Ω	Open or short														
Motor for compressor (MC) 	Measure the resistance between the terminals with a tester. (Winding temperature 68°F [20°C]) <table border="1" style="margin-top: 10px;"> <thead> <tr> <th>Normal</th> <th>Abnormal</th> </tr> </thead> <tbody> <tr> <td>0.188 Ω</td> <td>Open or short</td> </tr> </tbody> </table>		Normal	Abnormal	0.188 Ω	Open or short									
Normal	Abnormal														
0.188 Ω	Open or short														
Solenoid valve coil <Bypass valve> (SV1)	Measure the resistance between the terminals with a tester. (Surrounding temperature 68°F [20°C]) <table border="1" style="margin-top: 10px;"> <thead> <tr> <th>Normal</th> <th>Abnormal</th> </tr> </thead> <tbody> <tr> <td>1183 ± 100 Ω</td> <td>Open or short</td> </tr> </tbody> </table>		Normal	Abnormal	1183 ± 100 Ω	Open or short									
Normal	Abnormal														
1183 ± 100 Ω	Open or short														
Rush current protect resistor (RS) only PUMY-P48NHMU <sub>1</sub> (-BS)	Measure the resistance between the terminals with a tester. <table border="1" style="margin-top: 10px;"> <thead> <tr> <th>Normal</th> <th>Abnormal</th> </tr> </thead> <tbody> <tr> <td>5.6 Ω ± 5%</td> <td>Open* or short</td> </tr> </tbody> </table> <p>*In case of open failure, check ACTM with a tester as well.            (Refer to 9-9. Test point ; the item of ACTM)</p>		Normal	Abnormal	5.6 Ω ± 5%	Open* or short									
Normal	Abnormal														
5.6 Ω ± 5%	Open* or short														
52C relay (52C)  only PUMY-P48NHMU <sub>1</sub> (-BS)	Measure the resistance between the terminals with a tester. <table border="1" style="margin-top: 10px;"> <thead> <tr> <th>Normal</th> <th>Abnormal</th> </tr> </thead> <tbody> <tr> <td>Coil (A1-A2) Reference value : 1.45 kΩ</td> <td>Open or short</td> </tr> </tbody> </table>		Normal	Abnormal	Coil (A1-A2) Reference value : 1.45 kΩ	Open or short									
Normal	Abnormal														
Coil (A1-A2) Reference value : 1.45 kΩ	Open or short														
Reactor (DCL) 	Measure the resistance between the terminals with a tester. <table border="1" style="margin-top: 10px;"> <thead> <tr> <th>Normal</th> <th>Abnormal</th> </tr> </thead> <tbody> <tr> <td>Reference value : 0.04 Ω</td> <td>Open or short*</td> </tr> </tbody> </table> <p>*Because the resistor of the reactor is little, it is difficult to determine if it is short or normal with an ordinary tester.</p>		Normal	Abnormal	Reference value : 0.04 Ω	Open or short*									
Normal	Abnormal														
Reference value : 0.04 Ω	Open or short*														

## Check method of DC fan motor (fan motor/outdoor controller circuit board)

### ① Notes

- High voltage is applied to the connector (CNF1, 2) for the fan motor. Pay attention to the service.
- Do not pull out the connector (CNF1, 2) for the motor with the power supply on.  
(It causes trouble of the outdoor controller circuit board and fan motor.)

### ② Self check

Symptom : The outdoor fan cannot rotate.

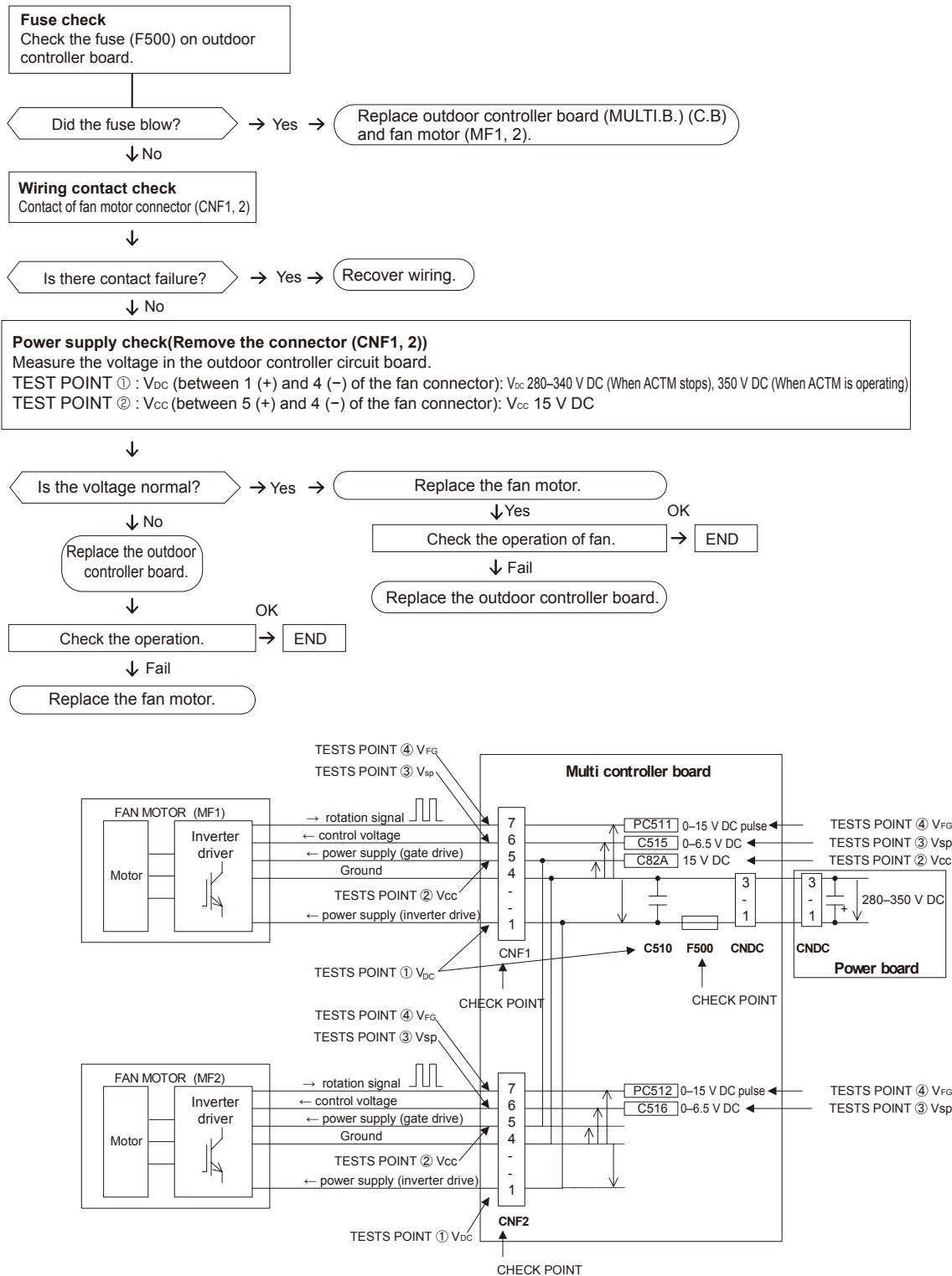

- The inverter control P.C. board is built in the fan motor of this outdoor unit.
- When F500 that is on controller board is blown, change the fan motor and multi controller board at the same time (F500 is impossible to change).
- For outdoor unit, there are 2 fan motors (up and down; MF1/MF2), it is possible to connect to either CNF1 or CNF2 on the board.
- It is abnormal when the abnormality is detected from either both fan motors or only one side.

## Check method of multi controller board

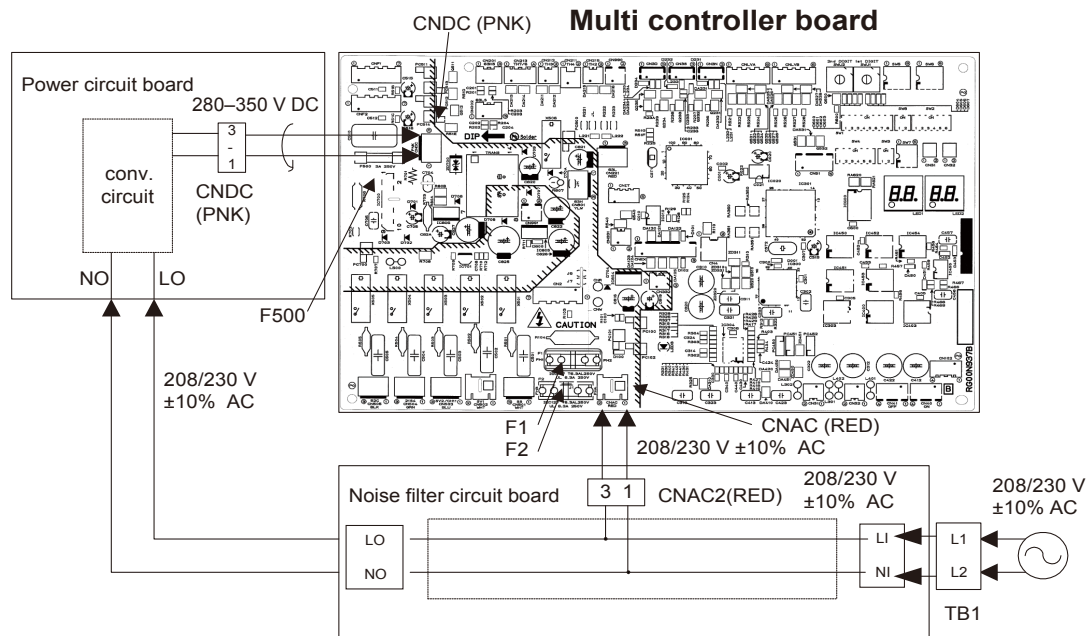
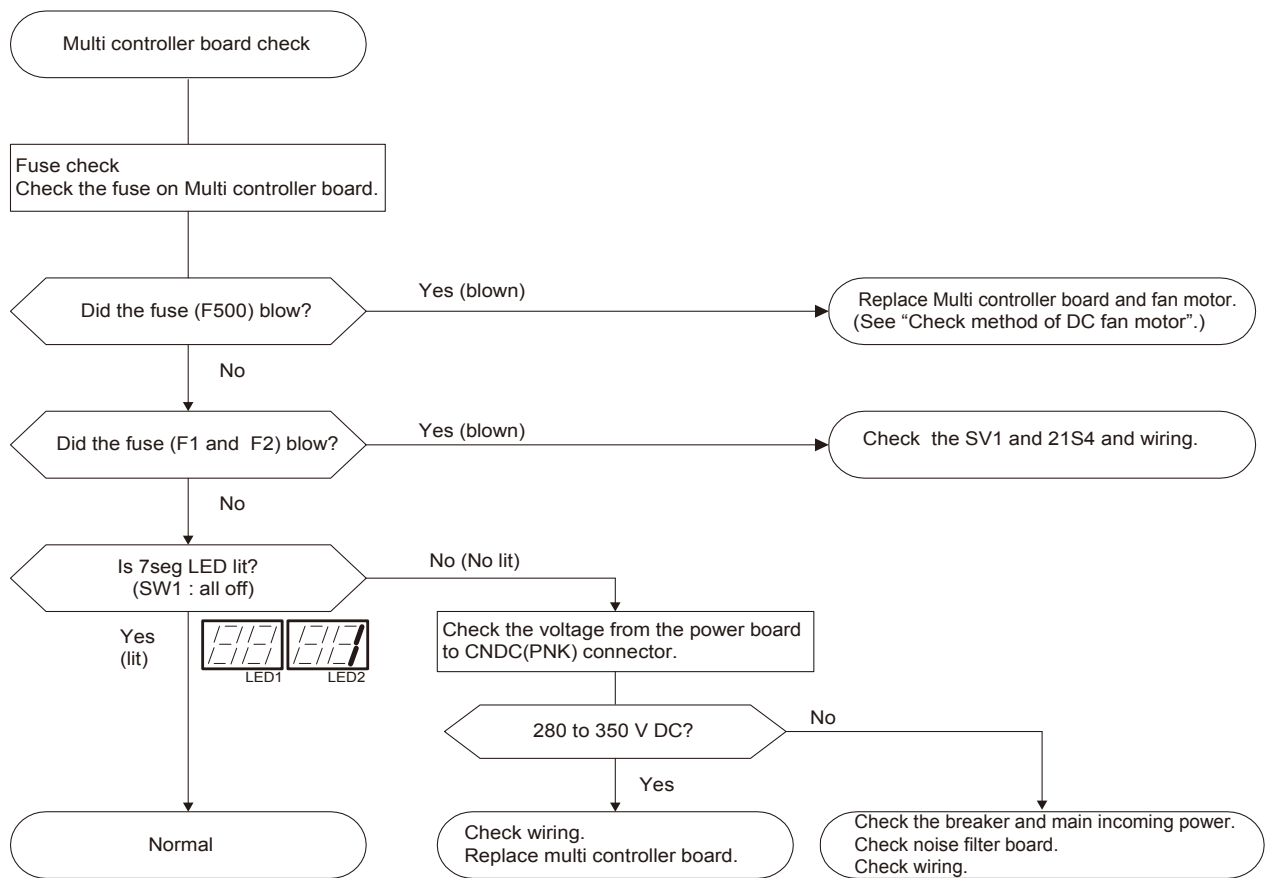

# Check method of power board

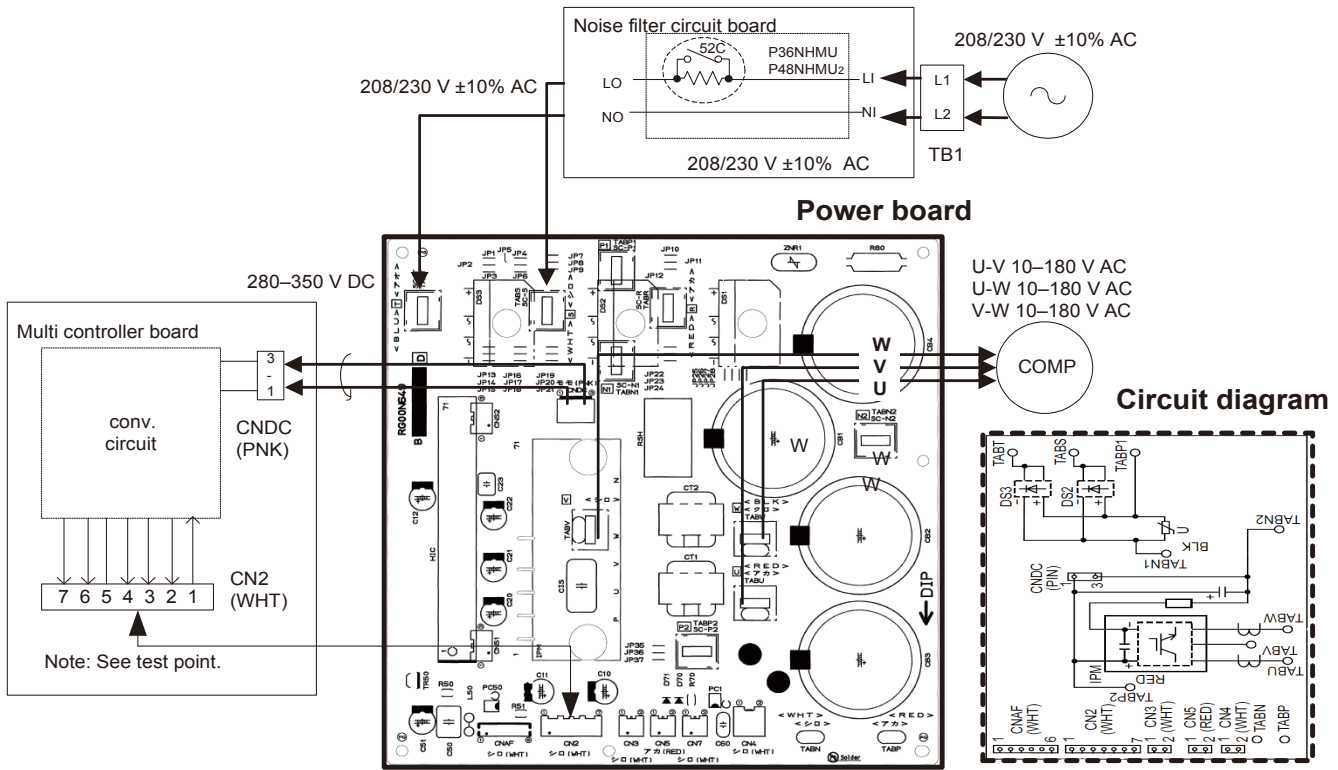
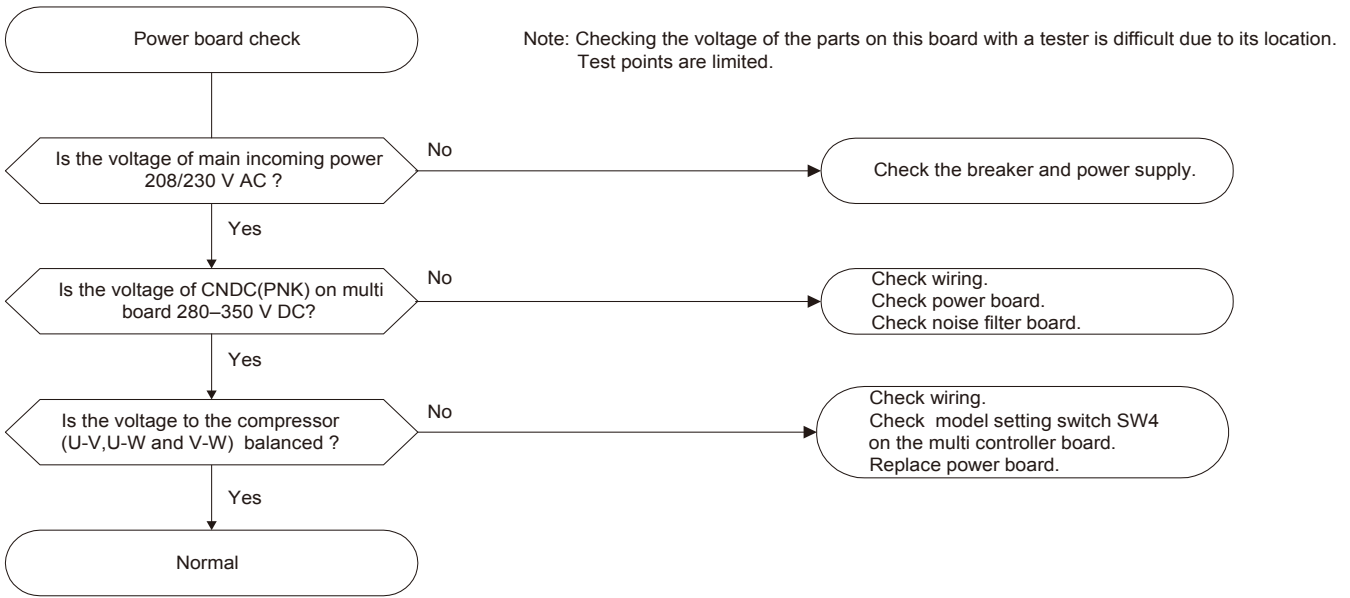

# Check method of noise filter circuit board

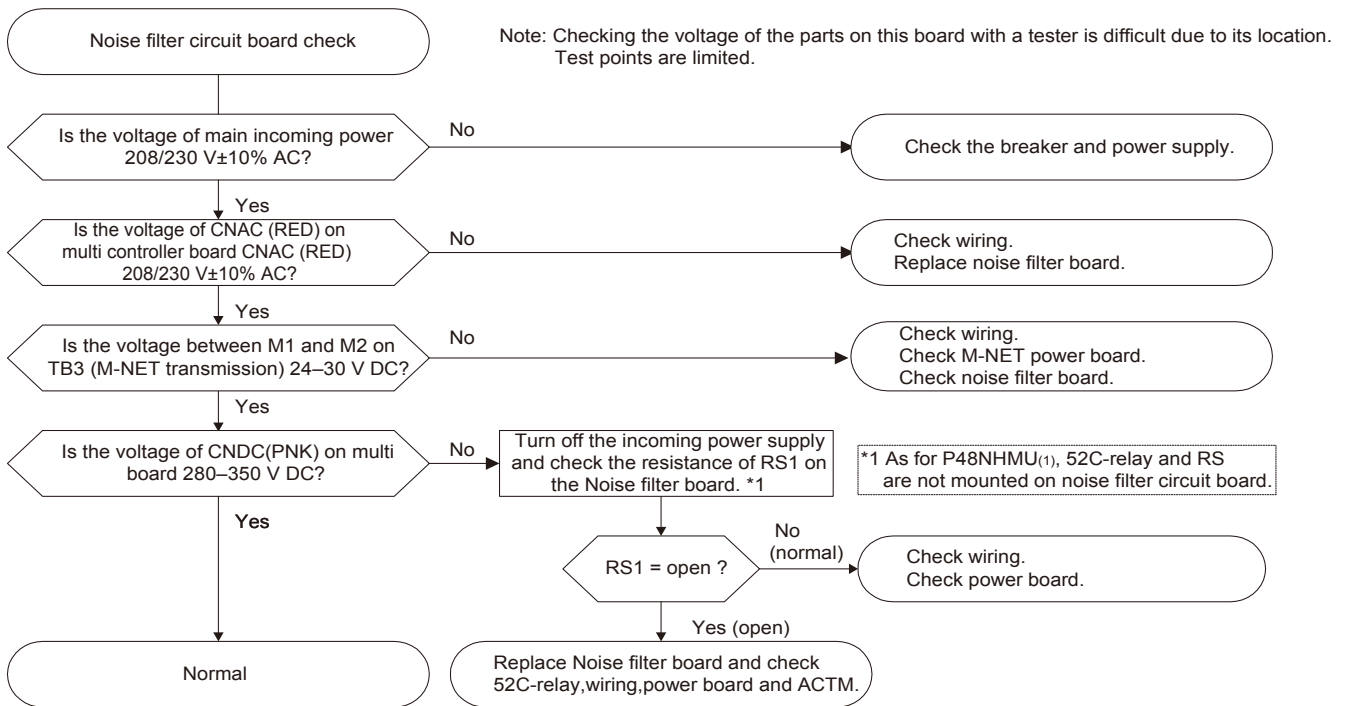

## Circuit diagram

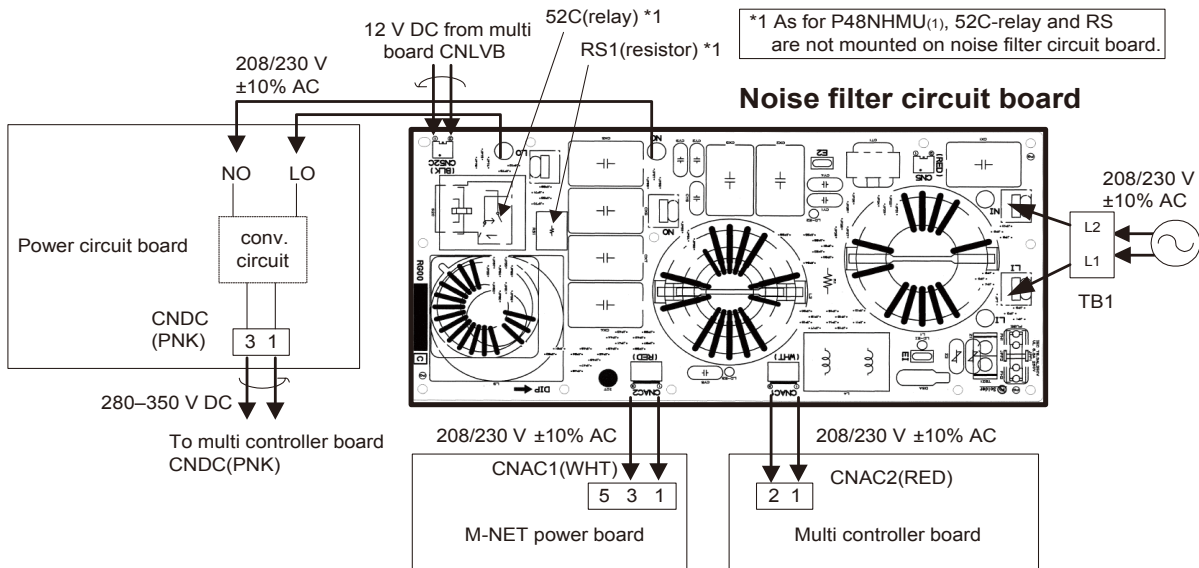
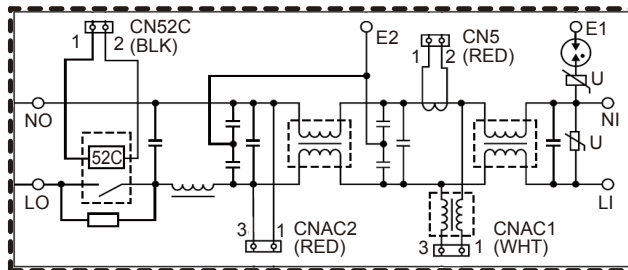

# Check method of ACTM

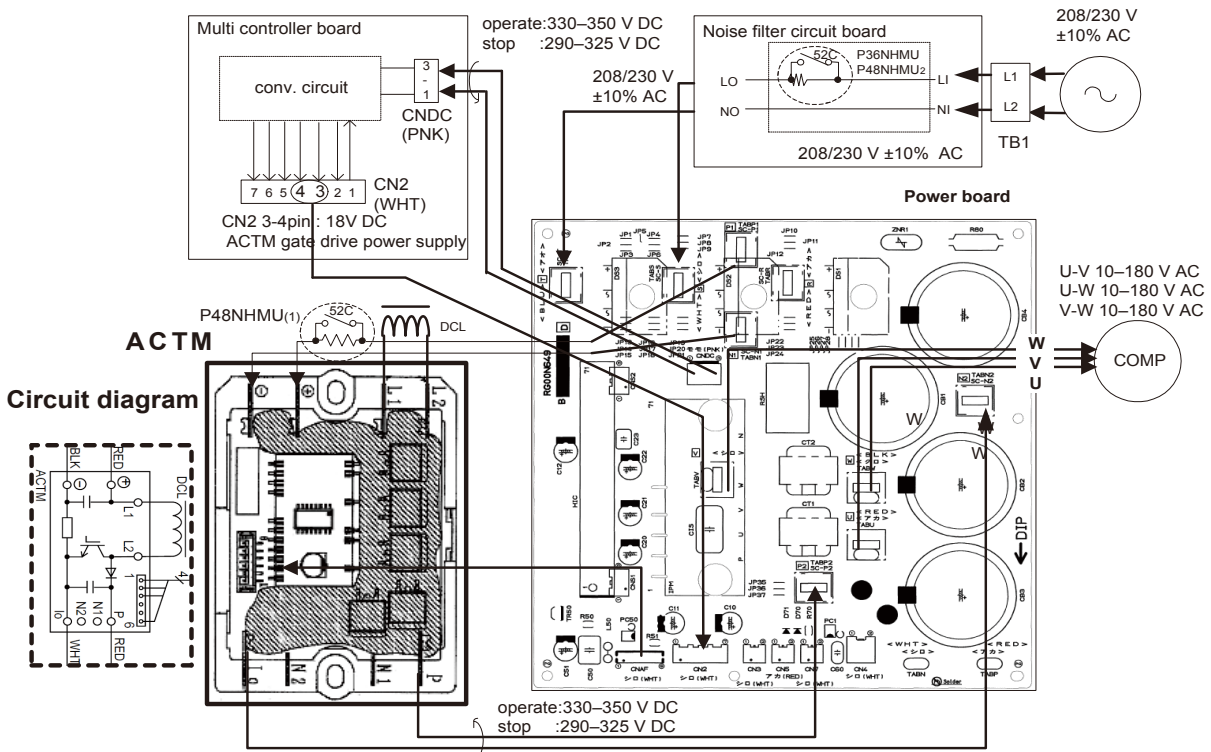
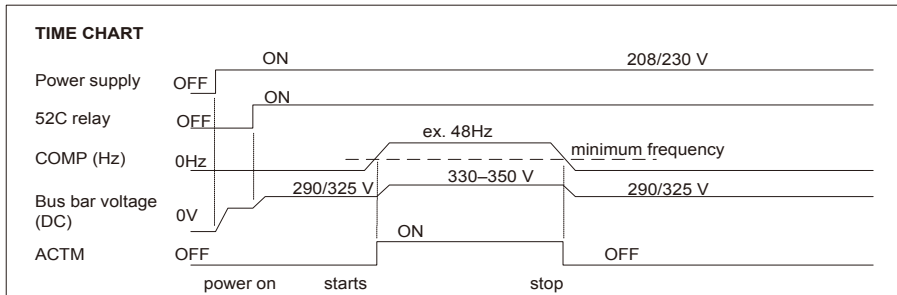
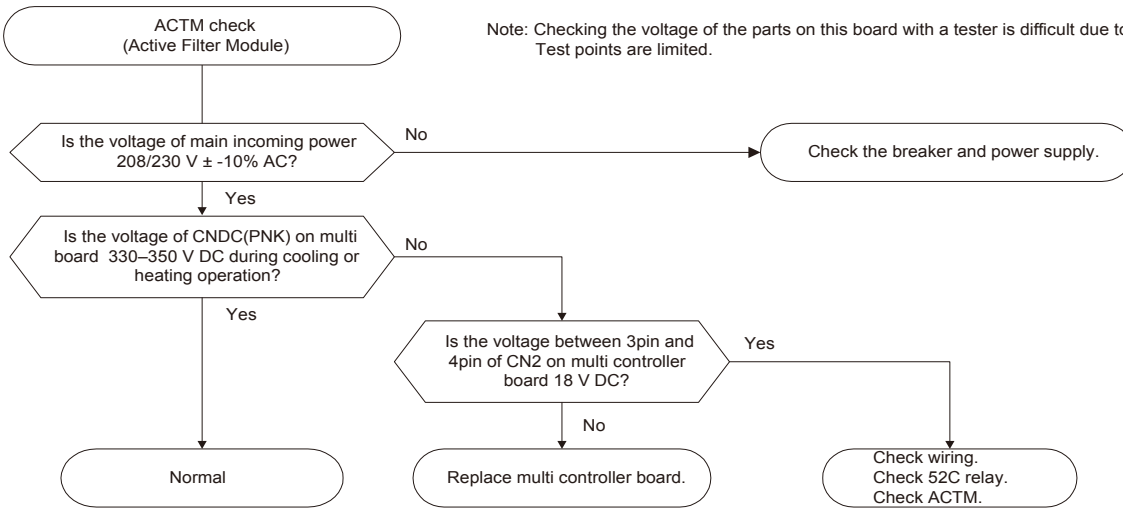

# Check method of M-NET transmission power board

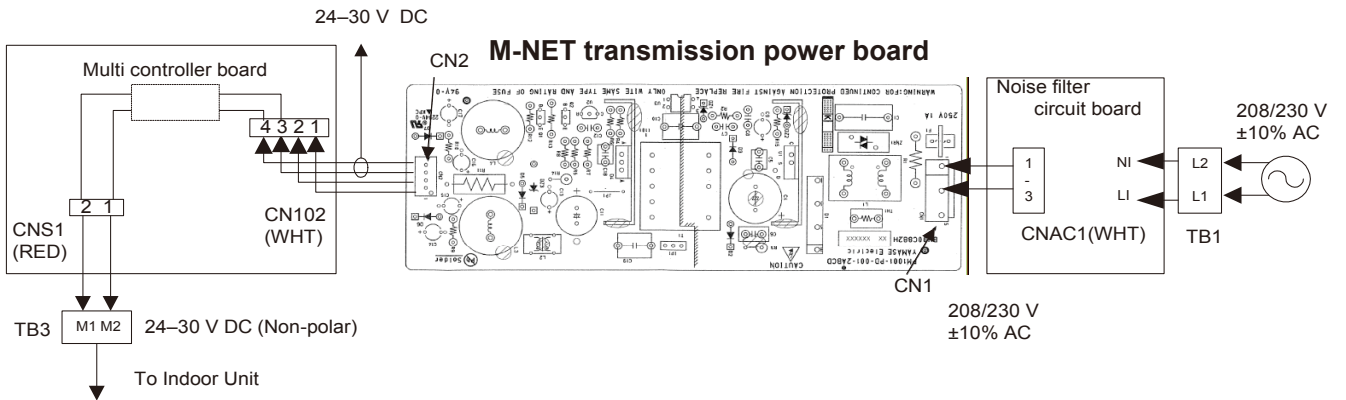
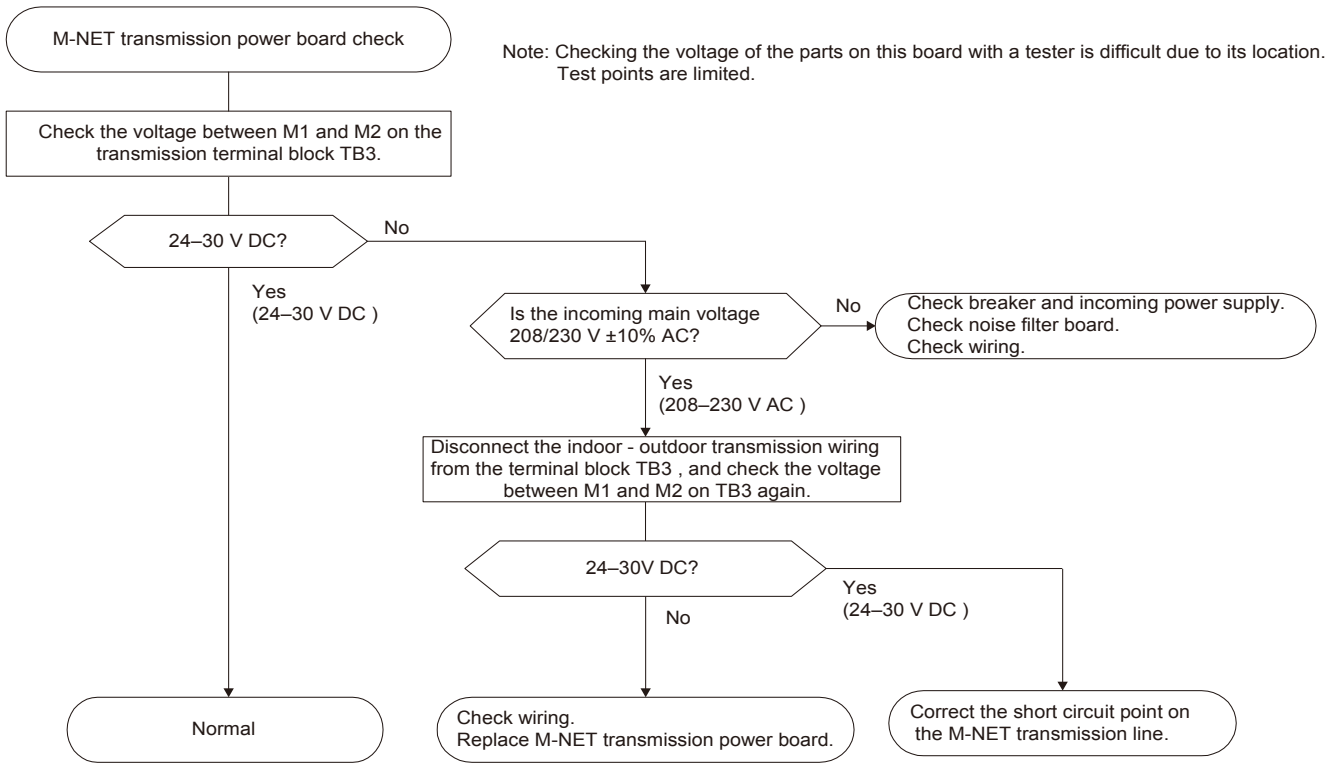

## 9-8. HOW TO CHECK THE COMPONENTS

### <HIGH PRESSURE SENSOR>

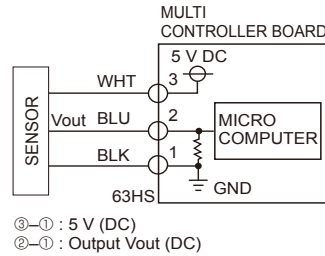
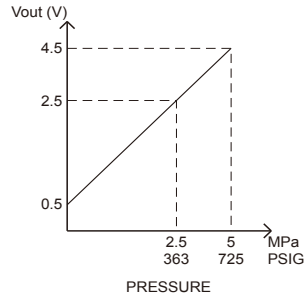

### <Thermistor feature chart>

#### Low temperature thermistors

- Thermistor <Outdoor pipe> (TH3)
- Thermistor <Low pressure saturated temperature> (TH6)
- Thermistor <Outdoor> (TH7)

Thermistor R0 = 15 kΩ ± 3%

B constant = 3480 ± 2%

$$R_t = 15 \exp\left\{3480\left(\frac{1}{273+t} - \frac{1}{273}\right)\right\} \quad t: ^\circ\text{C} = (^\circ\text{F}-32)/1.8$$

32°F [0°C]	15 kΩ
50°F [10°C]	9.6 kΩ
68°F [20°C]	6.3 kΩ
77°F [25°C]	5.2 kΩ
86°F [30°C]	4.3 kΩ
104°F [40°C]	3.0 kΩ

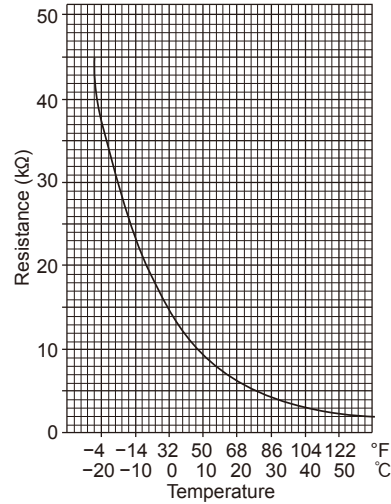

#### Medium temperature thermistor

Heat sink temperature thermistor (TH8)

Thermistor R50 = 17 kΩ ± 2%

B constant = 4170 ± 3%

$$R_t = 17 \exp\left\{4170\left(\frac{1}{273+t} - \frac{1}{323}\right)\right\} \quad t: ^\circ\text{C} = (^\circ\text{F}-32)/1.8$$

32°F [0°C]	180 kΩ
77°F [25°C]	50 kΩ
122°F [50°C]	17 kΩ
158°F [70°C]	8 kΩ
194°F [90°C]	4 kΩ

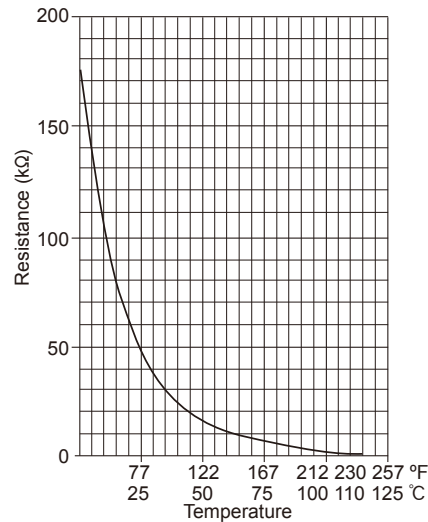

#### High temperature thermistor

- Thermistor <Discharge/Compressor> (TH4)

Thermistor R120 = 7.465 kΩ ± 2%

B constant = 4057 ± 2%

$$R_t = 7.465 \exp\left\{4057\left(\frac{1}{273+t} - \frac{1}{393}\right)\right\} \quad t: ^\circ\text{C} = (^\circ\text{F}-32)/1.8$$

68°F [20°C]	250 kΩ	158°F [70°C]	34 kΩ
86°F [30°C]	160 kΩ	176°F [80°C]	24 kΩ
104°F [40°C]	104 kΩ	194°F [90°C]	17.5 kΩ
122°F [50°C]	70 kΩ	212°F [100°C]	13.0 kΩ
140°F [60°C]	48 kΩ	230°F [110°C]	9.8 kΩ

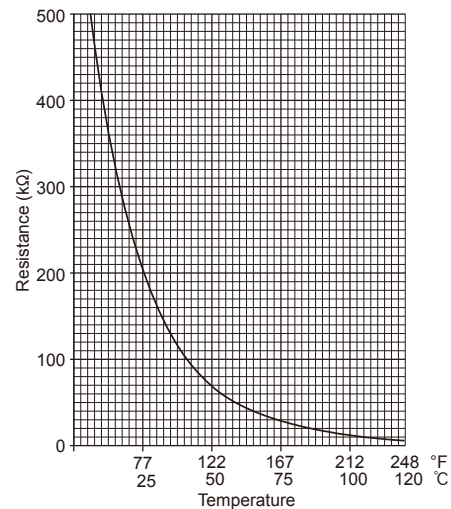

# 9-9. TEST POINT DIAGRAM

## Outdoor multi controller board

PUMY-P36NHMU(-BS)

PUMY-P48NHMU(-BS)

PUMY-P48NHMUR3(-BS)

PUMY-P36NHMUR1(-BS)

PUMY-P48NHMU<sub>1</sub>(-BS)

PUMY-P48NHMUR4(-BS)

PUMY-P36NHMUR4(-BS)

PUMY-P48NHMU<sub>2</sub>(-BS)

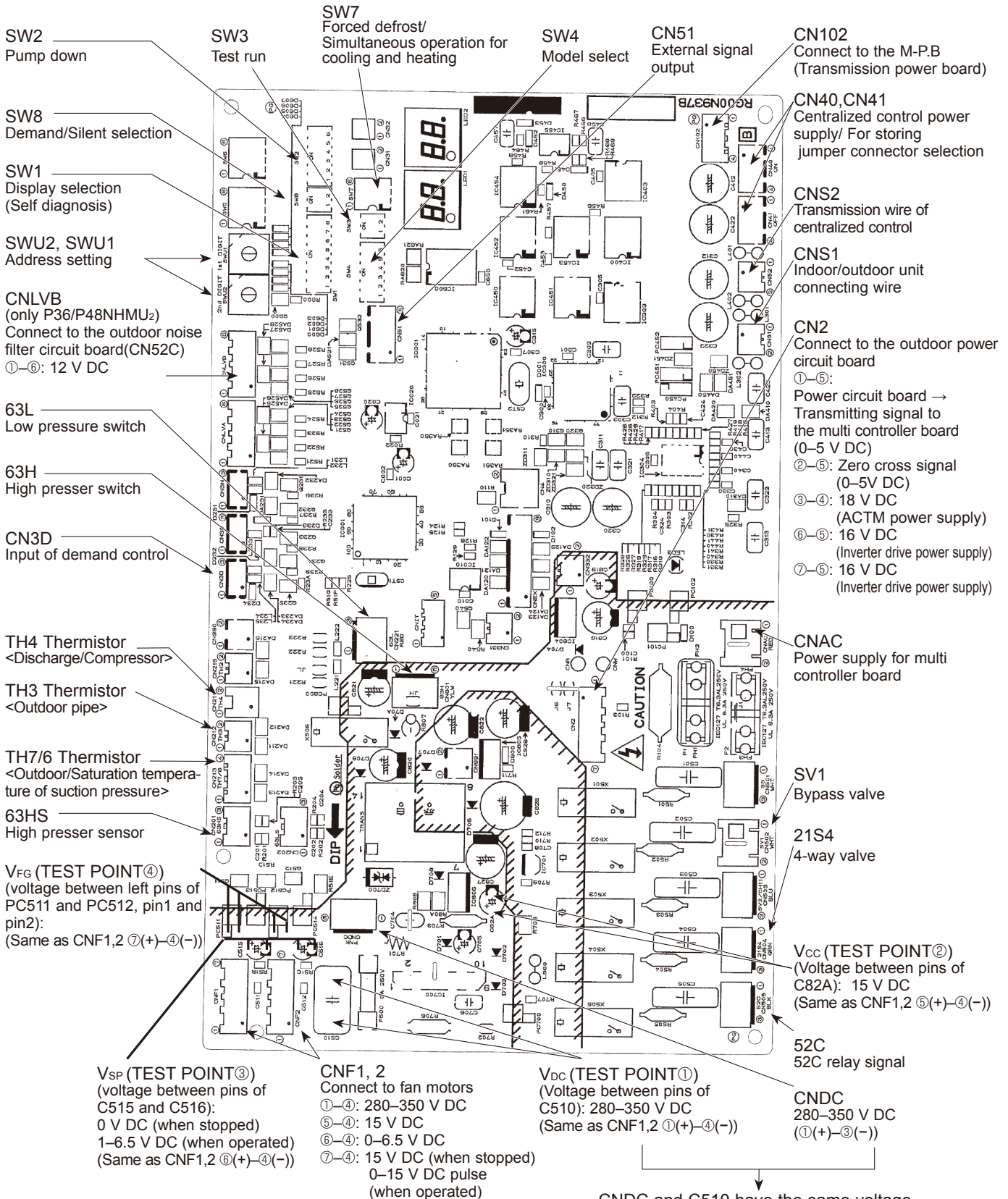

CNDC and C510 have the same voltage.  
Also possible to check at self check No. 45  
SW1: 10110100



**Outdoor noise filter circuit board**  
**PUMY-P48NHMU**  
**PUMY-P48NHMU-BS**  
**PUMY-P48NHMU<sub>1</sub>**  
**PUMY-P48NHMU<sub>1</sub>-BS**

LO, NO  
 Voltage of 208–230 V AC is output  
 (Connect to the outdoor power  
 circuit board)

TABS

TABT

CNAC2  
 208/230 V AC  
 (Connect to the  
 outdoor control-  
 ler circuit board  
 (CNAC))

CNAC1  
 208/230 V AC  
 (Connect to the  
 M-NET power cir-  
 cuit board  
 (M-P.B.))

EI  
 Connect to  
 the earth

CN5  
 Primary current  
 (Connect to the  
 outdoor power  
 circuit board  
 (CN5))

Current  
 transformer  
 (Primary current)

LI, NI  
 Voltage of 208/230 V AC is input  
 (Connect to the terminal block (TB1))

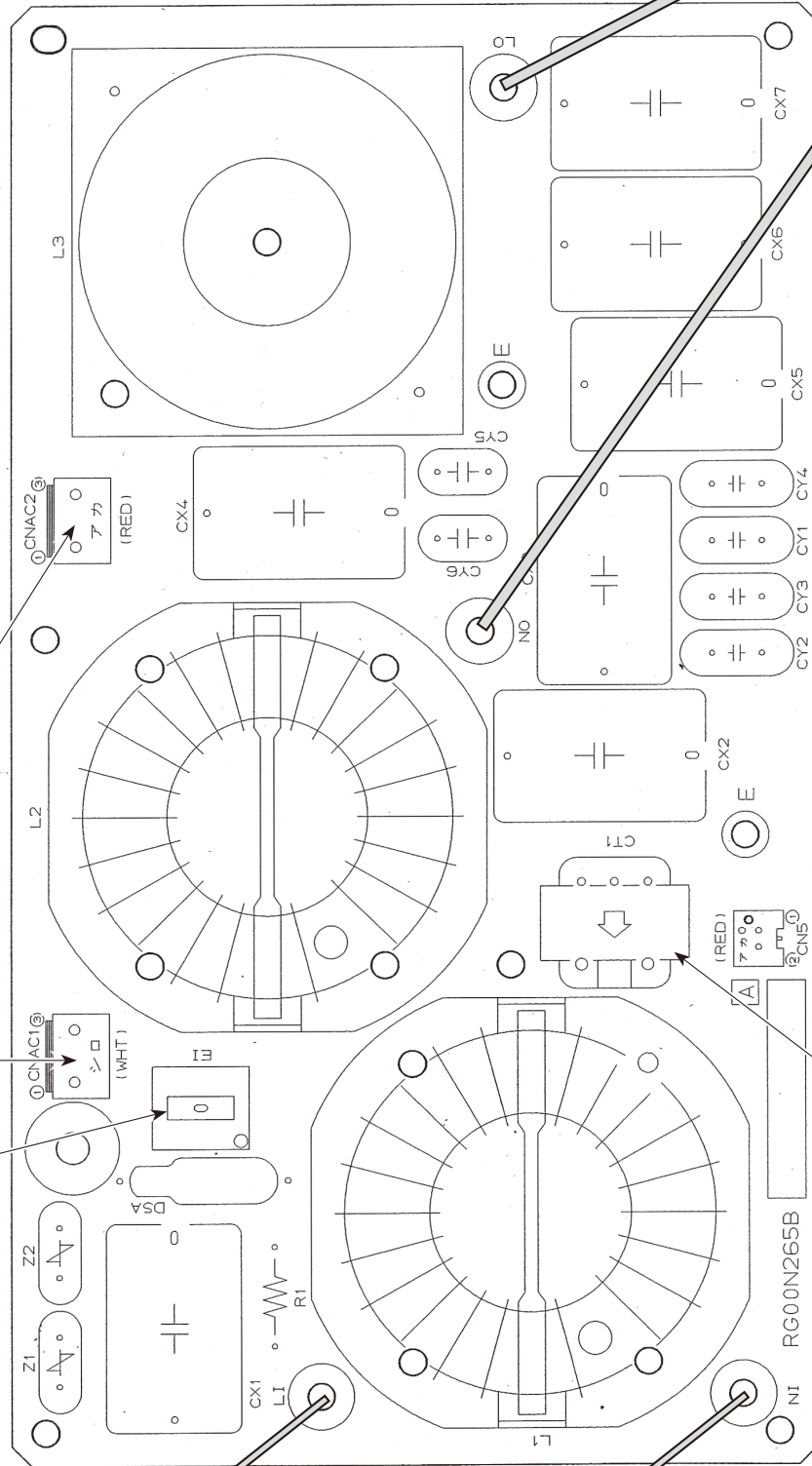

**Outdoor noise filter circuit board**  
**PUMY-P36NHMU(-BS)**  
**PUMY-P36NHMUR1(-BS)**  
**PUMY-P36NHMUR4(-BS)**  
**PUMY-P48NHMU<sub>2</sub>(-BS)**  
**PUMY-P48NHMUR3(-BS)**  
**PUMY-P48NHMUR4(-BS)**

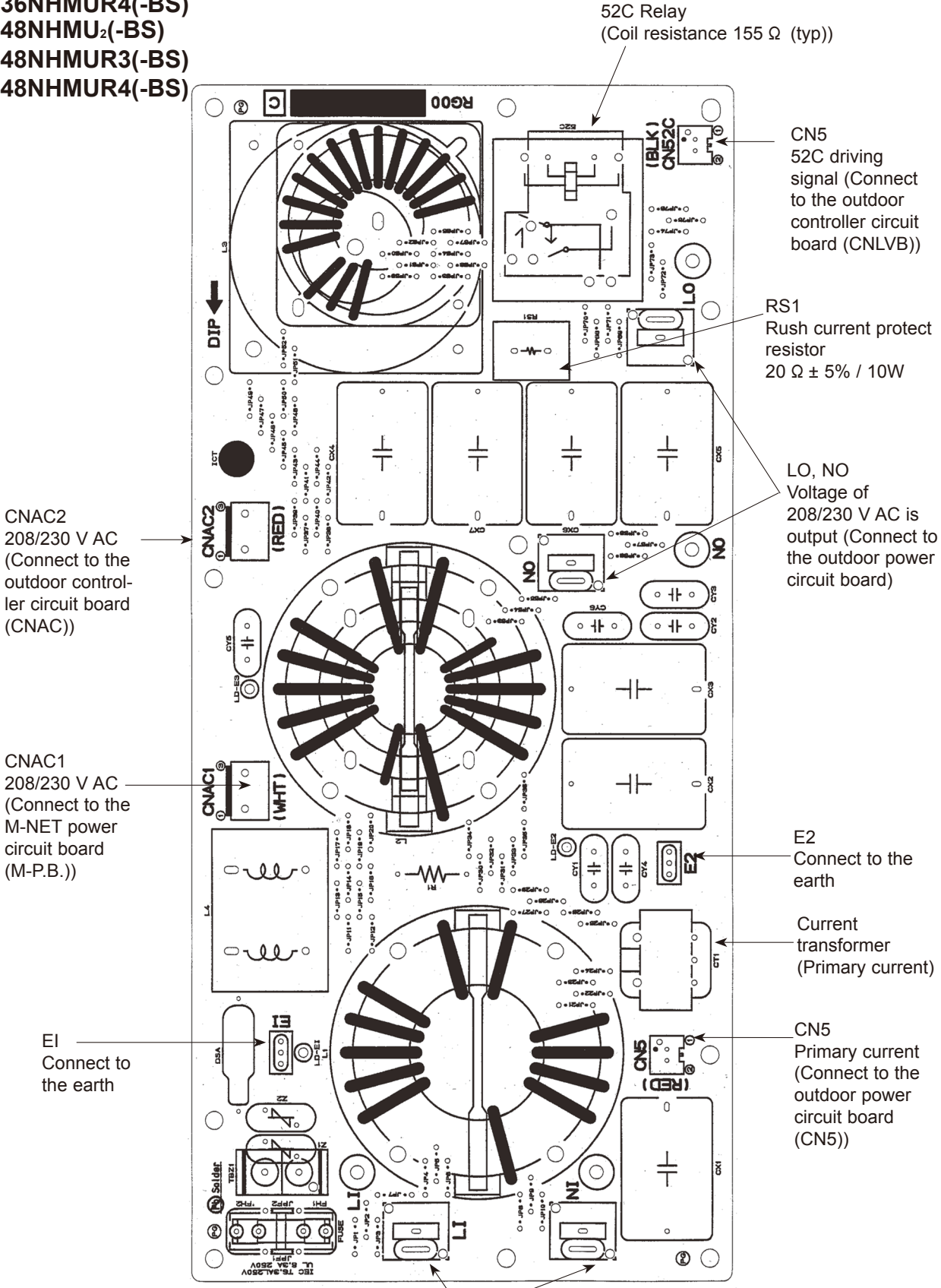

52C Relay  
 (Coil resistance 155 Ω (typ))

CN5  
 52C driving  
 signal (Connect  
 to the outdoor  
 controller circuit  
 board (CNLVB))

RS1  
 Rush current protect  
 resistor  
 20 Ω ± 5% / 10W

LO, NO  
 Voltage of  
 208/230 V AC is  
 output (Connect to  
 the outdoor power  
 circuit board)

CNAC2  
 208/230 V AC  
 (Connect to the  
 outdoor controller  
 circuit board  
 (CNAC))

CNAC1  
 208/230 V AC  
 (Connect to the  
 M-NET power  
 circuit board  
 (M-P.B.))

E2  
 Connect to the  
 earth

Current  
 transformer  
 (Primary current)

E1  
 Connect to  
 the earth

CN5  
 Primary current  
 (Connect to the  
 outdoor power  
 circuit board  
 (CN5))

LI, NI  
 Voltage of 208/230 V AC is input  
 (Connect to the terminal block (TB1))

Transmission power board

PUMY-P36NHMU(-BS)  
 PUMY-P48NHMU(-BS)  
 PUMY-P48NHMUR3(-BS)

PUMY-P36NHMUR1(-BS)  
 PUMY-P48NHMU<sub>1</sub>(-BS)  
 PUMY-P48NHMUR4(-BS)

PUMY-P36NHMUR4(-BS)  
 PUMY-P48NHMU<sub>2</sub>(-BS)

CN1  
 Connect to the outdoor  
 noise filter circuit board  
 ①-③: 208/230 V AC

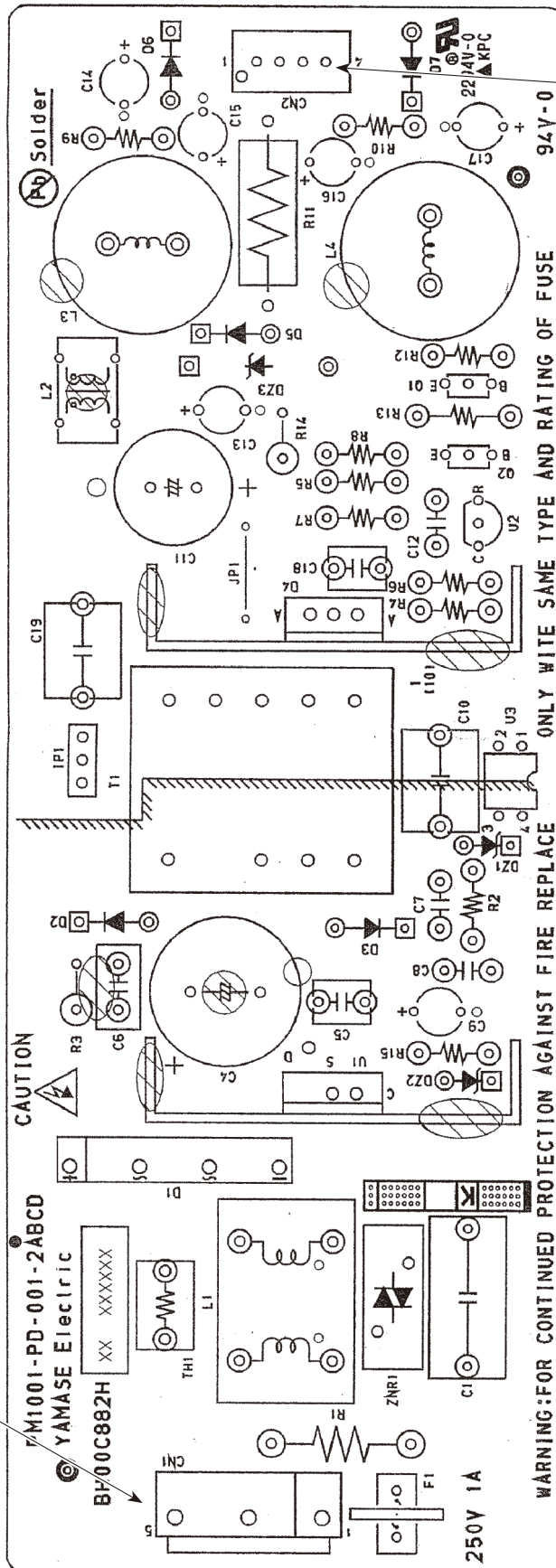

CN2  
 Connect to the outdoor multi  
 controller board  
 ①-②: 24-30 V DC  
 ③-④: 24-30 V DC



### Active filter module

PUMY-P36NHMU(-BS)

PUMY-P36NHMUR1(-BS)

PUMY-P36NHMUR4(-BS)

PUMY-P48NHMUR3(-BS)

PUMY-P48NHMU<sub>2</sub>(-BS)

PUMY-P48NHMUR4(-BS)

P  
Connect to the outdoor power circuit board (TABP2)

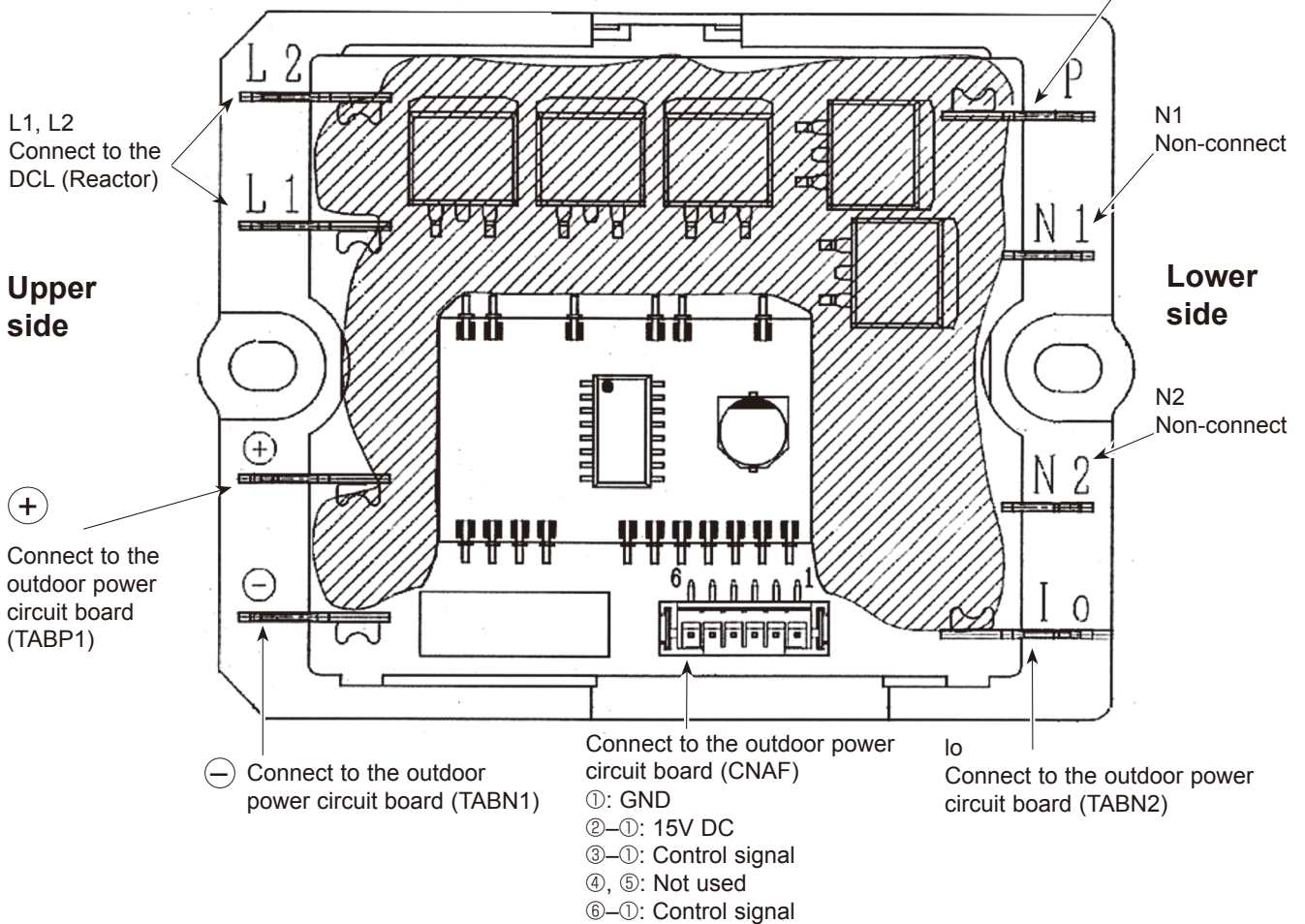

### Connection and internal circuit diagram

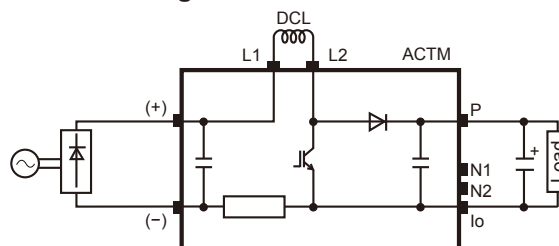

### Tester check points of Active filter module

	Error condition	Normal value (reference)	Symptom when the unit is in trouble
(-) and I <sub>o</sub>	open	less than 1 Ω	① The unit does not operate (cannot be switched ON)
(-) and L <sub>2</sub>	short	100 kΩ to 1 MΩ	① The breaker operates
	open	*	① The unit does not operate (cannot be switched ON) ②4220 Abnormal stop (9-10. No.189 "ACTM error" display)
P and L <sub>2</sub>	short	100 kΩ to 1 MΩ	① The breaker operates
	open	*	① The unit does not operate (cannot be switched ON) ②4220 Abnormal stop (9-10. No.189 "ACTM error" display)
P and I <sub>o</sub>	short	100 kΩ to 1 MΩ	① The breaker operates
	open	*	① The unit does not operate (cannot be switched ON) ②4220 Abnormal stop (9-10. No.189 "ACTM error" display)
L <sub>2</sub> and I <sub>o</sub>	short	100 kΩ to 1 MΩ	① The breaker operates
	open	*	① The unit does not operate (cannot be switched ON) ②4220 Abnormal stop (9-10. No.189 "ACTM error" display)

\* The symptom when the unit is in open error condition is described to determine open error by tester check.

# 9-10. OUTDOOR UNIT FUNCTIONS

SW:setting  
0...OFF  
1...ON

No.	SW1 setting	Display mode	Display on the LED1, 2 (display data)							Notes
0	12345678	Relay output display	1	2	4	5	6	7	8	Lighting always ON: light on OFF: light off
0	00000000	Check display	Compressor operation	52C	SV1	(SV2)				•When abnormality occurs, check display.
1	10000000	Indoor unit check status	No.1 unit check	No.2 unit check	No.4 unit check	No.5 unit check	No.6 unit check	No.7 unit check	No.8 unit check	Check: light on Normal: light off
2	01000000	Protection input	High-pressure abnormality	SH(low discharge temperature) abnormality	Discharge/Comp. temperature abnormality	TH4 abnormality	Outdoor fan rotational frequency abnormality	TH7 abnormality	TH8 abnormality	Display input microprocessor protection (abnormality)
3	11000000	Protection input	Heat Sink overheating	Overcurrent interception	Voltage abnormality	Insufficient refrigerant amount abnormality	Low-pressure abnormality	63HS abnormality	start over current interception abnormality	Display all abnormalities remaining in abnormality delay
4	00100000	Protection input	Abnormality in the number of indoor units setting	Address double	Indoor unit capacity error	Over capacity	Outdoor unit address error	Current sensor open/short	serial communication abnormality	
5	10100000	Abnormality delay display 1	High-pressure abnormality delay	SH(low discharge temperature) abnormality delay	Discharge/Comp. temperature abnormality delay	TH4 abnormality delay	Outdoor fan rotational frequency abnormality delay	TH7 abnormality delay	TH8 abnormality delay	Display all abnormalities remaining in abnormality delay
6	01100000	Abnormality delay display 2	Heat Sink overheating delay	Over current interception delay	Voltage abnormality delay	Insufficient refrigerant amount abnormality delay	Low-pressure abnormality delay	63HS abnormality delay	start over current interception abnormality delay	
7	11100000	Abnormality delay display 3				Frozen protection delay	TH6 abnormality delay	Current sensor open/short delay	communication/POWER BOARD abnormality delay	Display all abnormalities remaining in abnormality delay
8	00010000	Abnormality delay history 1	High-pressure abnormality delay	SH(low discharge temperature) abnormality delay	Discharge/Comp. temperature abnormality delay	TH4 abnormality delay	Outdoor fan rotational frequency abnormality delay	TH7 abnormality delay	TH8 abnormality delay	
9	10010000	Abnormality delay history 2	Heat Sink overheating delay	Overcurrent interception delay	Voltage abnormality delay	Insufficient refrigerant amount abnormality delay	Low-pressure abnormality delay	63HS abnormality delay	start over current interception abnormality delay	Display all abnormalities remaining in abnormality delay history
10	01010000	Abnormality delay history 3				Frozen protection delay	TH6 abnormality delay	Current sensor open/short delay	communication/POWER BOARD abnormality delay	
11	11010000	Abnormality code history 1 (the latest)								<ul style="list-style-type: none"> <li>•Display abnormalities up to present (including abnormality terminals)</li> <li>•History record in 1 is the latest; records become older in sequence; history record in 10 is the oldest.</li> </ul>
12	00110000	Abnormality code history 2								
13	10110000	Abnormality code history 3								
14	01110000	Abnormality code history 4								
15	11110000	Abnormality code history 5								
16	00001000	Abnormality code history 6								
17	10001000	Abnormality code history 7								
18	01001000	Abnormality code history 8								
19	11001000	Abnormality code history 9								
20	00101000	Abnormality code history 10 (the oldest)								
21	10101000	Cumulative time	0-9999 (unit: 1-hour)							Display of cumulative compressor operating time
22	01101000	Cumulative time	0-9999 (unit: 10-hour)							
23	11101000	Outdoor unit operation display	Excitation Current	Restart after: 3 minutes	Compressor operation	Abnormality(detection)				Cooling : light on Heating: light blinking Stop fan: light off
24	00011000	Indoor unit operation mode	No.1 unit mode	No.2 unit mode	No.3 unit mode	No.4 unit mode	No.5 unit mode	No.6 unit mode	No.8 unit mode	Thermo ON : light on Thermo OFF : light off
25	10011000	Indoor unit operation display	No.1 unit operation	No.2 unit operation	No.3 unit operation	No.4 unit operation	No.5 unit operation	No.6 unit operation	No.7 unit operation	•Display of indoor unit capacity code
26	01011000	Capacity code (No. 1 indoor unit)	0-255							<ul style="list-style-type: none"> <li>•The No. 1 unit will start from the address with the lowest number</li> </ul>
27	11011000	Capacity code (No. 2 indoor unit)								
28	00111000	Capacity code (No. 3 indoor unit)								
29	10111000	Capacity code (No. 4 indoor unit)								
30	01111000	Capacity code (No. 5 indoor unit)								

Abnormality delay	Delay code	Abnormality delay	Delay code
Discharge/Comp. temperature abnormality	1202	High-pressure abnormality	1402
Discharge/Comp. temperature sensor (TH4) abnormality	1205	Pressure sensor (63HS) abnormality	1600
Outdoor pipe temperature sensor (TH3) abnormality	1211	Over charge refrigerant abnormality	1601
Saturation temperature of suction pressure sensor (TH6) abnormality	1214	Insufficient refrigerant abnormality	4320
Radiator panel thermistor (TH8) abnormality	1221	Frequency converter insufficient wiring voltage abnormality	4330
Outdoor temperature sensor (TH7) abnormality		Heat Sink temperature abnormality	4350
		Power module abnormality	

No.	SW1 setting	Display mode	Display on the LED1, 2 (display data)								Notes		
			1	2	3	4	5	6	7	8			
31	11111000	IC1 operation mode	OFF	Fan	Cooling thermo ON	Cooling thermo OFF	Heating thermo ON	Heating thermo OFF					•Display of indoor unit operating mode
32	00000100	IC2 operation mode											
33	10000100	IC3 operation mode											
34	01000100	IC4 operation mode											
35	11000100	IC5 operation mode											
36	00100100	OC operation mode	ON/OFF	Heating/Cooling	Abnormal/Normal	DEFROST/NO	P94:Demand	Refrigerant pull back/no	Excitation current/no	3-min.delay/no			Light on/light off
37	10100100	External connection status	P97:Autochange over permission CN3N1-3 input	P96:Autochange over fixed mode CN3N1-2 input	P95:Undefined CN3S1-2 input	P94:Demand CN3D1-3 input	P93:Silent CN3D1-2 input						Input: light off No input: light on
38	01100100	Communication demand capacity	0-255										Display of communication demand capacity
39	11100100	Number of compressor ON/OFF	0000-9999 (unit : x10)										
40	00010100	Compressor operating current	0-999.9 (A)										
41	10010100	Input current of outdoor unit	0-999.9 (A)										
42	01010100	Thermo ON operating time	0000-9999 (unit : x10)										
43	11010100	Total capacity of thermo on	0-255										
44	00110100	Number of indoor units	0-255										
45	10110100	DC bus voltage	0-999.9 (V)										
46	01110100	State of LEV control	Td over heat prevention	SHd decrease prevention	Min-Sj correction depends on Td	LEV opening correction depends on Pd	LEV opening correction depends on Td	LEV opening correction depends on Td	Correction of high compression ratio prevention				Freeze prevention control
47	11110100	State of compressor frequency control 1	Discharge pressure control	Discharge/Comp. temperature control				Pd abnormality control (heating)	Discharge pressure (heating) Backup				
48	00001100	State of compressor frequency control 2	Heatsink over heat prevention control	Secondary current control	Input current control			Frequency restrain of receipt voltage change					
49	10001100	Protection input					Frozen protection	TH6 abnormality	Power module abnormality				
50	01001100	The second current value when microprocessor of POWER BOARD abnormality is detected	0-999.9[Arms]										
51	11001100	The radiator panel temperature when microprocessor of POWER BOARD abnormality is detected	-99.9-999.9 (Short/Open: -99.9 or 999.9)										
State of compressor frequency(Hz) control (Words)			Content										
Discharge pressure control			Hz control by pressure limitation										
Discharge/Comp. temperature control			Hz control by discharge temperature limitation										
Max.Hz control			Max.Hz limitation when power supply on										
SV control			Hz control by bypass valve										
Abnormal rise of Pd control			Control that restrains abnormal rise of discharge pressure										
Heat sink overheat prevention control			Heatsink over heat prevention control										
Secondary current control			Secondary current control										
Input current control			Input current control										
Hz correction of receipt voltage decrease prevention			Max.Hz correction control due to voltage decrease										
Hz restrain of receipt voltage change			Max.Hz correction control due to receipt voltage change										

No.	SW1 setting 12345678	Display mode	Display on the LED1, 2 (display data)								Notes
			1	2	3	4	5	6	7	8	
64	00000010	Operational frequency	0-FF(hexadecimal number)								Display of actual operating frequency
65	10000010	Target frequency	0-255								Display of target frequency
66	01000010	Outdoor fan control step number	0-15								Display of number of outdoor fan control steps (target)
67	11000010	EER fan control step number (cooling)									
69	10100010	IC1 LEV Opening pulse	0-2000								Display of opening pulse of outdoor SLEV and indoor LEV
70	01100010	IC2 LEV Opening pulse									
71	11100010	IC3 LEV Opening pulse									
72	00010010	IC4 LEV Opening pulse									
73	10010010	IC5 LEV Opening pulse									
74	01010010	High-pressure sensor (Pd) kgf/cm <sup>2</sup>									
75	11010010	TH4(Td) °C	-99.9-999.9								Display of outdoor subcool (SC) data and detection data from high-pressure sensor and each thermistor
76	00110010	TH6(ET) °C									
77	10110010	TH7(Outdoor-temp.) °C									
78	01110010	TH3(Outdoor pipe) °C									
80	00001010	TH8(Power module) °C									
81	10001010	IC1 TH23(Gas) °C	-99.9-999.9								
82	01001010	IC2 TH23(Gas) °C	(When the indoor unit is not connected, it is displayed as"0".)								
83	11001010	IC3 TH23(Gas) °C									
84	00101010	IC4 TH23(Gas) °C									
85	10101010	IC5 TH23(Gas) °C									
86	01101010	IC1 TH22(Liquid) °C									
87	11101010	IC2 TH22(Liquid) °C									
88	00011010	IC3 TH22(Liquid) °C									
89	10011010	IC4 TH22 (Liquid) °C									
90	01011010	IC5 TH22 (Liquid) °C									
91	11011010	IC1 TH21(Intake) °C									
92	00111010	IC2 TH21 (Intake) °C									
93	10111010	IC3 TH21 (Intake) °C									
94	01111010	IC4 TH21 (Intake) °C									
95	11111010	IC5 TH21 (Intake) °C									
96	00000110	Outdoor SC (cooling) °C	-99.9-999.9								



No.	SW1 setting 12345678	Display mode	Display on the LED1, 2 (display data)								Notes		
			1	2	3	4	5	6	7	8			
136	00010001	High-pressure sensor data at time of abnormality delay kgf/cm <sup>2</sup>										Display of data from high-pressure sensor, all thermistors, and SC/SH at time of abnormality delay	
137	10010001	TH4 sensor data at time of abnormality delay °C											
138	01010001	TH6 sensor data at time of abnormality delay °C											
139	11010001	TH3 sensor data at time of abnormality delay °C											
140	00110001	TH8 sensor data at time of abnormality delay °C											
141	10110001	OC SC (cooling) at time of abnormality delay °C											
142	01110001	IC1 SC/SH at time of abnormality delay °C											
143	11110001	IC2 SC/SH at time of abnormality delay °C											
144	00001001	IC3 SC/SH at time of abnormality delay °C											
145	10001001	IC4 SC/SH at time of abnormality delay °C											
146	01001001	IC5 SC/SH at time of abnormality delay °C											
147	11001001	IC1 TH21 Intake °F											
148	00101001	IC2 TH21 Intake °F											
149	10101001	IC3 TH21 Intake °F											
150	01101001	IC4 TH21 Intake °F											
151	11101001	IC5 TH21 Intake °F											
152	00011001	IC6 TH21 Intake °F											
153	10011001	IC7 TH21 Intake °F											
154	01011001	IC8 TH21 Intake °F											
155	11011001	IC1 TH23 Gas °F											
156	00111001	IC2 TH23 Gas °F											
157	10111001	IC3 TH23 Gas °F											
158	01111001	IC4 TH23 Gas °F											
159	11111001	IC5 TH23 Gas °F											
160	00000101	IC6 TH23 Gas °F											
161	10000101	IC7 TH23 Gas °F											
162	01000101	IC8 TH23 Gas °F											
170	01010101	ROM version monitor										Display of version data of ROM	
171	11010101	ROM type											Display of ROM type
172	00110101	Check Sum code											
173	10110101	IC1 TH22 Liquid °F											Display of detection data from each indoor liquid pipe thermistor
174	01110101	IC2 TH22 Liquid °F											

No.	SW1 setting 12345678	Display mode	Display on the LED1, 2 (display data)								Notes
			1	2	3	4	5	6	7	8	
175	11110101	IC3 TH22 Liquid °F	-99.9-999.9 [°F] (When the indoor unit is not connected, it is displayed as "32".)								Display of detection data from each indoor liquid pipe thermistor
176	00001101	IC4 TH22 Liquid °F									
177	10001101	IC5 TH22 Liquid °F									
178	01001101	IC6 TH22 Liquid °F									
179	11001101	IC7 TH22 Liquid °F									
180	00101101	IC8 TH22 Liquid °F									
181	10101101	Auxiliary heating control setting temp. a°C	-12°C ≤ a < b < c < d ≤ 40°C or a = c and b = d, -12°C ≤ a < d ≤ 40°C Initial value a = -12°C, b = 0°C, c = 10°C, d = 20°C								
182	01101101	Auxiliary heating control setting temp. b°C									
183	11101101	Auxiliary heating control setting temp. c°C									
184	00011101	Auxiliary heating control setting temp. d°C									
185	10011101	Auxiliary heating control setting temp. a°F	10.4°F ≤ a < b < c < d ≤ 104°F or a = c and b = d, 10.4°F ≤ a < d ≤ 104°F Initial value a = 10.4°F, b = 32°F, c = 50.0°F, d = 68.0°F								
186	01011101	Auxiliary heating control setting temp. b°F									
187	11011101	Auxiliary heating control setting temp. c°F									
188	00111101	Auxiliary heating control setting temp. d°F									
189	10111101	4220 Error history	—	—	—	—	—	—	—	—	Over voltage
192	00000011	Actual frequency at time of abnormality	Display of actual frequency at time of abnormality								
193	10000011	Fan step number at time of abnormality	0-FF(16 progressive)								
195	11000011	IC1 LEV opening pulse at time of abnormality	0-20								
196	00100011	IC2 LEV opening pulse at time of abnormality	0-2000								
197	10100011	IC3 LEV opening pulse at time of abnormality									
198	01100011	IC4 LEV opening pulse at time of abnormality									
199	11100011	IC5 LEV opening pulse at time of abnormality									
200	00010011	High-pressure sensor data at abnormality kgf/cm²	Display of data from high-pressure sensor and all thermistors at time of abnormality								
201	10010011	TH4 sensor data at time of abnormality °C									
202	01010011	TH6 sensor data at time of abnormality °C									
203	11010011	TH3 sensor data at time of abnormality °C									
204	00110011	TH8 sensor data at time of abnormality °C									
206	01110011	IC1 SC/SH at time of abnormality °C	-99.9-999.9								
207	11110011	IC2 SC/SH at time of abnormality °C									
208	00001011	IC3 SC/SH at time of abnormality °C									
209	10001011	IC4 SC/SH at time of abnormality °C									
210	01001011	IC5 SC/SH at time of abnormality °C									

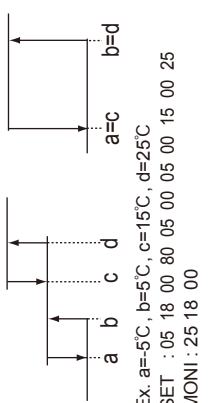

No.	SW1 setting 12345678	Display mode	Display on the LED1, 2 (display data)								Notes
			1	2	3	4	5	6	7	8	
211	11001011	IC6 Capacity code	0-255								Display of indoor unit capacity mode
212	00101011	IC7 Capacity code									
213	10101011	IC8 Capacity code									
214	01101011	IC6 operation mode									
215	11101011	IC7 operation mode									
216	00011011	IC8 operation mode									
217	10011011	IC6 LEV opening pulse	0-2000								Display of opening pulse of outdoor SLEV and indoor LEV
218	01011011	IC7 LEV opening pulse									
219	11011011	IC8 LEV opening pulse									
220	00111011	IC6 TH23(Gas) °C									
221	10111011	IC7 TH23(Gas) °C									
222	01111011	IC8 TH23(Gas) °C									
223	11111011	IC6 TH22(Liquid) °C									
224	00001111	IC7 TH22(Liquid) °C									
225	10001111	IC8 TH22(Liquid) °C									
226	01001111	IC6 TH21(Intake) °C									
227	11001111	IC7 TH21(Intake) °C									
228	00100111	IC8 TH21(Intake) °C									
229	10100111	IC6 SC/SH °C									
230	01100111	IC7 SC/SH °C									
231	11100111	IC8 SC/SH °C									
232	00010111	IC6 target SC/SH °C									
233	10010111	IC7 target SC/SH °C									
234	01010111	IC8 target SC/SH °C	SCm/SHm (0.0-14.0)								Display of all control target data
235	11010111	IC6 LEV opening pulse at abnormality delay									
236	00110111	IC7 LEV opening pulse at abnormality delay	0-2000								Display of opening pulse of indoor LEV at time of abnormality
237	10110111	IC8 LEV opening pulse at abnormality delay									
238	01110111	IC6 SC/SH at abnormality delay °C									
239	11110111	IC7 SC/SH at abnormality delay °C									
240	00001111	IC8 SC/SH at abnormality delay °C									
241	10001111	IC6 LEV opening pulse at time of abnormality									
242	01001111	IC7 LEV opening pulse at time of abnormality	0-2000								Display of opening pulse of indoor LEV at time of abnormality
243	11001111	IC8 LEV opening pulse at time of abnormality									
244	00101111	IC6 SC/SH at abnormality °C									
245	10101111	IC7 SC/SH at abnormality °C									
246	01101111	IC8 SC/SH at abnormality °C									

This chapter provides an introduction to electrical wiring for the CITY MULTI-S series, together with notes concerning power wiring, wiring for control (transmission wires and remote controller wires), and the frequency converter.

**10-1. OVERVIEW OF POWER WIRING**

- (1) Use a separate power supply for the outdoor unit and indoor unit.
- (2) Bear in mind ambient conditions (ambient temperature, direct sunlight, rain water, etc.) when proceeding with the wiring and connections.
- (3) The wire size is the minimum value for metal conduit wiring. The power cord size should be 1 rank thicker consideration of voltage drops. Make sure the power-supply voltage does not drop more than 10%.
- (4) Specific wiring requirements should adhere to the wiring regulations of the region.
- (5) Power supply cords of parts of appliances for outdoor use shall not be lighter than polychloroprene sheathed flexible cord. For example, use wiring such as YZW.
- (6) Install an earth longer than other cables.
- (7) Use copper supply wires. Use electric wires over the rating voltage 300 V.

**⚠ Warning:**

- Be sure to use specified wires to connect so that no external force is imparted to terminal connections. If connections are not fixed firmly, it may cause heating or fire.
- Be sure to use the appropriate type of overcurrent protection switch. Note that generated overcurrent may include some amount of direct current.

**⚠ Caution:**

- Some installation site may require attachment of an earth leakage breaker. If no earth leakage breaker is installed, it may cause an electric shock.
- Do not use anything other than breaker and fuse with correct capacity. Using fuse and wire or copper wire with too large capacity may cause a malfunction of unit or fire.

**10-2. WIRE DIAMETER AND MAIN POWER SWITCH CAPACITY**

**10-2-1. Wiring diagram for main power supply**

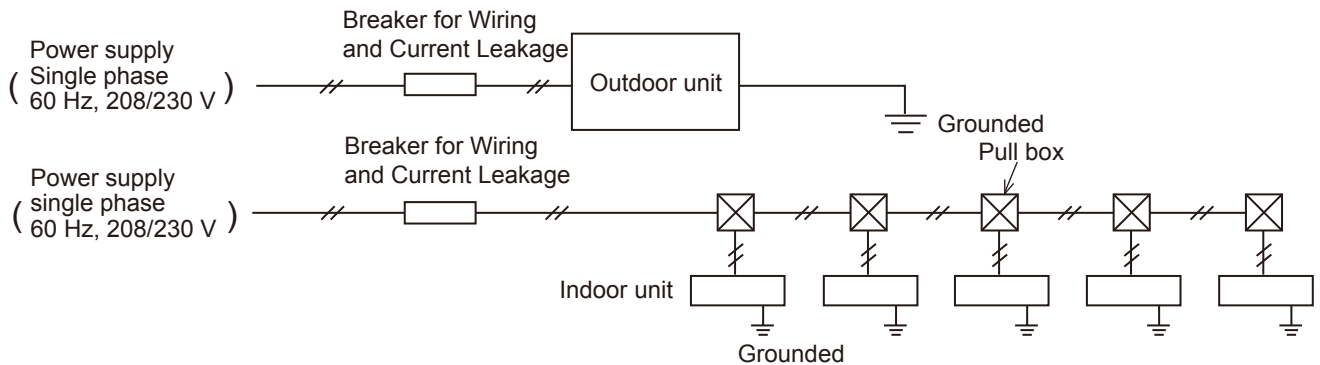

**10-2-2. Power supply wire diameter and capacity**

Model	Power Supply	Minimum Wire Thickness (AWG[mm <sup>2</sup> ])		Breaker for Wiring*1	Breaker for Current Leakage	Minimum circuit ampacity	Maximum rating of over current protector device
		Main Cable*2	Ground				
Outdoor Unit P36/48	~N (single), 60 Hz, 208/230 V	AWG10 [5.3]	AWG10 [5.3]	30 A	30 A 30 mA 0.1 s or less	26 A	40 A
Indoor Unit	~N (single), 60 Hz, 208/230 V	Refer to installation manual of indoor unit.					

\*1 A breaker with at least 3.0 mm contact separation in each pole shall be provided. Use earth leakage breaker (NV).

\*2 Use copper supply wires. Use the electric wires over the rating voltage 300V.

### 10-3. DESIGN FOR CONTROL WIRING

Please note that the types and numbers of control wires needed by the CITY MULTI-S series will depend on the remote controllers and whether they are linked with the system.

#### 10-3-1. Selection number of control wires

		M-NET remote controller
Use		Remote controller used in system control operations. • Group operation involving different refrigerant systems. • Linked operation with upper control system.
Remote controller → indoor unit		2-core wires (non-polar)
Transmission wires	Wires connecting → indoor units	
	Wires connecting → indoor units with outdoor unit	
	Wires connecting → outdoor units	

#### 10-3-2. Control signal wires

##### • Transmission wires

- Types of transmission cables: Shielding wire (2-core) CVVS, CPEVS or MVVS.
- Cable diameter: More than AWG16 [1.25 mm<sup>2</sup>]
- Maximum wiring length: Within 656 ft [200 m]

#### 10-3-3. M-NET Remote controller wiring

Kind of remote control cable	Shielding wire (2-core) CVVS, CPEVS or MVVS.
Cable diameter	AWG 20 to AWG [160.5 to 1.25 mm <sup>2</sup> ]
Remarks	When 33 ft [10 m] is exceeded, use cable with the same specifications as "10-3-2. Control signal wires".

#### 10-3-4. MA Remote control cables

Kind of remote control cable	2-core cable (unshielded)
Cable diameter	AWG 22 to AWG 16 [0.3 to 1.25 mm <sup>2</sup> ]

### 10-4. SYSTEM SWITCH SETTING

In order to identify the destinations of signals to the outdoor units, indoor units, and remote controller of the MULTI-S series, each microprocessor must be assigned an identification number (address). The addresses of outdoor units, indoor units, and remote controller must be set using their settings switches. Please consult the installation manual that comes with each unit for detailed information on setting procedures.

### 10-5. EXAMPLE EXTERNAL WIRING DIAGRAM FOR A BASIC SYSTEM

Example using a M-NET remote controller

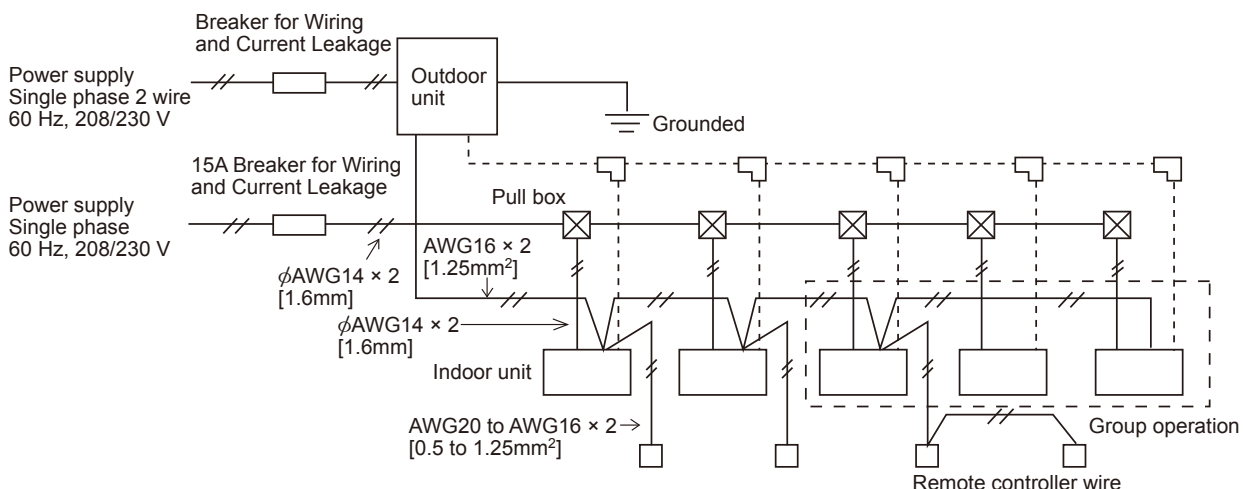

## 10-6. METHOD FOR OBTAINING ELECTRICAL CHARACTERISTICS WHEN A CAPACITY AGREEMENT IS TO BE SIGNED WITH AN ELECTRIC POWER COMPANY

The electrical characteristics of connected indoor unit system for air conditioning systems, including the MULTI-S series, will depend on the arrangement of the indoor and outdoor units.

First read the data on the selected indoor and outdoor units and then use the following formulas to calculate the electrical characteristics before applying for a capacity agreement with the local electric power company.

### 10-6-1. Obtaining the electrical characteristics of a CITY MULTI-S series system

#### (1) Procedure for obtaining total power consumption

	Page numbers in this technical manual	Power consumption
Total power consumption of each indoor unit	See the technical manual of each indoor unit	①
Power consumption of outdoor unit *1	Standard capacity table— Refer to 5-3.	②
Total power consumption of system	See the technical manual of each indoor unit	①+② <kW>

\*1 Please note that the power consumption of the outdoor unit will vary depending on the total capacity of the selected indoor units.

#### (2) Method of obtaining total current

	Page numbers in this technical manual	Subtotal
Total current through each indoor unit	See the technical manual of each indoor unit	①
Current through outdoor unit	Standard capacity table— Refer to 5-3.	②
Total current through system	See the technical manual of each indoor unit	①+② <A>

\*2 Please note that the current through the outdoor unit will vary depending on the total capacity of the selected indoor units.

#### (3) Method of obtaining system power factor

Use the following formula and the total power and current obtained in parts ① and ② in the above table to calculate the system power factor.

$$\text{System power factor} = \frac{(\text{Total system power consumption})}{(\text{Total system current} \times \text{voltage})} \times 100\%$$

### 10-6-2. Applying to an electric power company for power and total current

Calculations should be performed separately for heating and cooling employing the same methods; use the largest resulting value in your application to the electric power company.

## 11-1. REFRIGERANT PIPING SYSTEM

**Line-Branch Method**  
 Connection Examples  
 (Connecting to 4 Indoor Units)

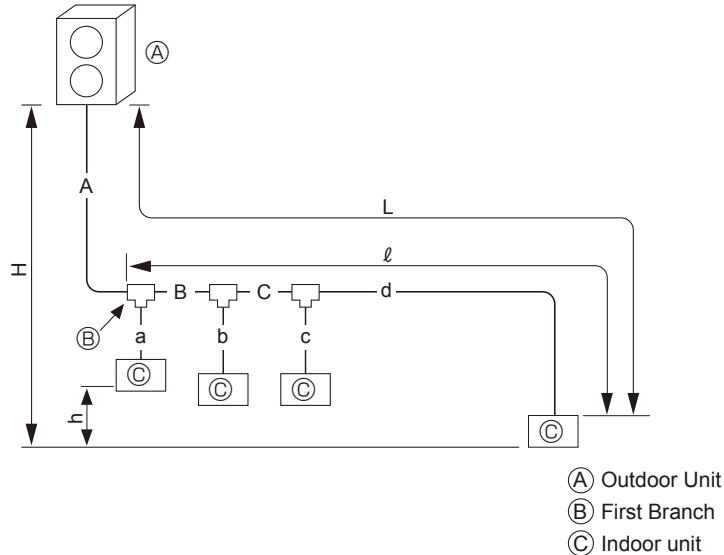

Permissible Length	Total Piping Length	$A+B+C+a+b+c+d \leq 394 \text{ ft} [120 \text{ m}]$
	Farthest Piping Length (L)	$A+B+C+d \leq 262 \text{ ft} [80 \text{ m}]$
	Farthest Piping Length After First Branch ( $\ell$ )	$B+C+d \leq 100 \text{ ft} [30 \text{ m}]$
Permissible High/Low Difference	High/Low Difference in Indoor/Outdoor Section (H)	164 ft [50 m] or less (If the outdoor unit is lower, 70 ft [20 m] or less)
	High/Low Difference in Indoor/Indoor Section (h)	39 ft [12 m] or less

■ **Selecting the Refrigerant Branch Kit** Use an optional branch piping kit ([CMY-Y62-G-E](#)).

■ <b>Select Each Section of Refrigerant Piping</b>  (1) Section From Outdoor Unit to First Branch (A) (2) Sections From Branch to Indoor Unit (a,b,c,d) (3) Section From Branch to Branch (B,C)  <b>Select the size from the right table.</b>	(1) Refrigerant Piping Diameter In Section From Outdoor Unit to First Branch (Outdoor Unit Piping Diameter)	(2) Refrigerant Piping Diameter In Section From Branch to Indoor Unit (Indoor Unit Piping Diameter)																					
	<table border="1"> <thead> <tr> <th>Model</th> <th colspan="2">Piping Diameter (in[mm])</th> </tr> </thead> <tbody> <tr> <td rowspan="2">PUMY-P36,48</td> <td>Liquid Line</td> <td><math>\phi 3/8 [9.52]</math></td> </tr> <tr> <td>Gas Line</td> <td><math>\phi 5/8 [15.88]</math></td> </tr> </tbody> </table>	Model	Piping Diameter (in[mm])		PUMY-P36,48	Liquid Line	$\phi 3/8 [9.52]$	Gas Line	$\phi 5/8 [15.88]$	<table border="1"> <thead> <tr> <th>Model number</th> <th colspan="2">Piping Diameter (in [mm])</th> </tr> </thead> <tbody> <tr> <td rowspan="2">18 or lower</td> <td>Liquid Line</td> <td><math>\phi 1/4 [6.35]</math></td> </tr> <tr> <td>Gas Line</td> <td><math>\phi 1/2 [12.7]</math></td> </tr> <tr> <td rowspan="2">24 to 54</td> <td>Liquid Line</td> <td><math>\phi 3/8 [9.52]</math></td> </tr> <tr> <td>Gas Line</td> <td><math>\phi 5/8 [15.88]</math></td> </tr> </tbody> </table>	Model number	Piping Diameter (in [mm])		18 or lower	Liquid Line	$\phi 1/4 [6.35]$	Gas Line	$\phi 1/2 [12.7]$	24 to 54	Liquid Line	$\phi 3/8 [9.52]$	Gas Line	$\phi 5/8 [15.88]$
	Model	Piping Diameter (in[mm])																					
PUMY-P36,48	Liquid Line	$\phi 3/8 [9.52]$																					
	Gas Line	$\phi 5/8 [15.88]$																					
Model number	Piping Diameter (in [mm])																						
18 or lower	Liquid Line	$\phi 1/4 [6.35]$																					
	Gas Line	$\phi 1/2 [12.7]$																					
24 to 54	Liquid Line	$\phi 3/8 [9.52]$																					
	Gas Line	$\phi 5/8 [15.88]$																					
(3) Refrigerant Piping Diameter In Section From Branch to Branch	<table border="1"> <thead> <tr> <th>Liquid Line (in [mm])</th> <th>Gas Line (in [mm])</th> </tr> </thead> <tbody> <tr> <td><math>\phi 3/8 [9.52]</math></td> <td><math>\phi 5/8 [15.88]</math></td> </tr> </tbody> </table>		Liquid Line (in [mm])	Gas Line (in [mm])	$\phi 3/8 [9.52]$	$\phi 5/8 [15.88]$																	
Liquid Line (in [mm])	Gas Line (in [mm])																						
$\phi 3/8 [9.52]$	$\phi 5/8 [15.88]$																						

■ <b>Additional refrigerant charge</b> <ul style="list-style-type: none"> <li>Refrigerant of 6.6 lbs [3 kg] equivalent to 165 ft [50 m] total extended piping length is already included when the outdoor unit is shipped. Thus, if the total extended piping length is 165 ft [50 m] or less, there is no need to charge with additional refrigerant.</li> <li>If the total extended piping length exceeds 165 ft [50 m], calculate the required additional refrigerant charge using the procedure shown on the right.</li> <li>If the calculated additional refrigerant charge is a negative amount, do not charge with any refrigerant.</li> </ul>	<Additional Charge>													
	<table border="1"> <tr> <td>Additional refrigerant charge</td> <td>=</td> <td>Liquid pipe size Total length of <math>\phi 3/8 \times 0.041 \text{ lbs} [9.52 \times 0.06 \text{ kg}]</math></td> <td>+</td> <td>Liquid pipe size Total length of <math>\phi 1/4 \times 0.016 \text{ lbs} [6.35 \times 0.024 \text{ kg}]</math></td> <td>-</td> <td>Refrigerant amount for outdoor unit</td> </tr> <tr> <td>(lb) [kg]</td> <td></td> <td>(ft) <math>\times 0.041</math> (lb/ft), [m] <math>\times 0.06</math> [kg/m]</td> <td></td> <td>(ft) <math>\times 0.016</math> (lb/ft), [m] <math>\times 0.024</math> [kg/m]</td> <td></td> <td>6.6 lbs [3.0 kg]</td> </tr> </table> <p>&lt;Example&gt;                  Outdoor model : P48                  Indoor                  1 : P24 A : <math>\phi 3/8</math> [9.52] 33 ft [10 m] a : <math>\phi 3/8</math> [9.52] 49 ft [15 m]                  2 : P15 B : <math>\phi 3/8</math> [9.52] 33 ft [10 m] b : <math>\phi 1/4</math> [6.35] 33 ft [10 m]                  3 : P08 C : <math>\phi 3/8</math> [9.52] 33 ft [10 m] c : <math>\phi 1/4</math> [6.35] 33 ft [10 m]                  4 : P06 d : <math>\phi 1/4</math> [6.35] 66 ft [20 m]</p> <p>The total length of each liquid line is as follows;  <math>\phi 3/8</math> [9.52] : <math>A + B + C + a = 33 \text{ ft} + 33 \text{ ft} + 33 \text{ ft} + 49 \text{ ft} = 148 \text{ ft} [10 \text{ m} + 10 \text{ m} + 10 \text{ m} + 15 \text{ m} = 45 \text{ m}]</math>  <math>\phi 1/4</math> [6.35] : <math>b + c + d = 33 \text{ ft} + 33 \text{ ft} + 66 \text{ ft} = 132 \text{ ft} [10 \text{ m} + 10 \text{ m} + 20 \text{ m} = 40 \text{ m}]</math></p> <Calculation example> Additional refrigerant charge = $148 \text{ ft} \times 0.041 \text{ lbs} + 132 \text{ ft} \times 0.016 \text{ lbs} - 6.6 \text{ lbs} = 1.58 \text{ lbs}$ = $[45 \text{ m} \times 0.06 \text{ kg} + 40 \text{ m} \times 0.024 \text{ kg} - 3.0 \text{ kg} = 0.7 \text{ kg} \text{ (rounded up)}]$	Additional refrigerant charge	=	Liquid pipe size Total length of $\phi 3/8 \times 0.041 \text{ lbs} [9.52 \times 0.06 \text{ kg}]$	+	Liquid pipe size Total length of $\phi 1/4 \times 0.016 \text{ lbs} [6.35 \times 0.024 \text{ kg}]$	-	Refrigerant amount for outdoor unit	(lb) [kg]		(ft) $\times 0.041$ (lb/ft), [m] $\times 0.06$ [kg/m]		(ft) $\times 0.016$ (lb/ft), [m] $\times 0.024$ [kg/m]	
Additional refrigerant charge	=	Liquid pipe size Total length of $\phi 3/8 \times 0.041 \text{ lbs} [9.52 \times 0.06 \text{ kg}]$	+	Liquid pipe size Total length of $\phi 1/4 \times 0.016 \text{ lbs} [6.35 \times 0.024 \text{ kg}]$	-	Refrigerant amount for outdoor unit								
(lb) [kg]		(ft) $\times 0.041$ (lb/ft), [m] $\times 0.06$ [kg/m]		(ft) $\times 0.016$ (lb/ft), [m] $\times 0.024$ [kg/m]		6.6 lbs [3.0 kg]								

**Header-Branch Method**  
Connection Examples  
(Connecting to 4 Indoor Units)

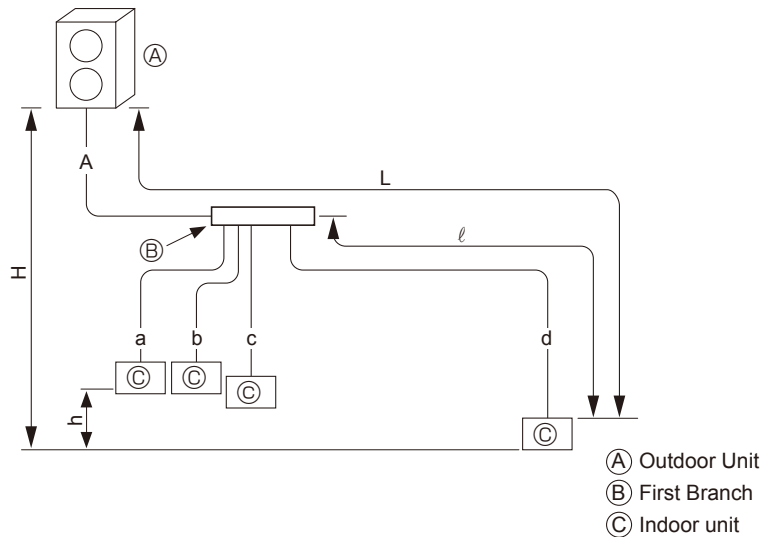

Permissible Length	Total Piping Length	$A+a+b+c+d \leq 394 \text{ ft [120 m]}$
	Farthest Piping Length (L)	$A+d \leq 262 \text{ ft [80 m]}$
	Farthest Piping Length After First Branch ( $\ell$ )	d is 100 ft [30 m] or less
Permissible High/Low Difference	High/Low Difference in Indoor/Outdoor Section (H)	164 ft [50 m] or less (If the outdoor unit is lower, 70 ft [20 m] or less)
	High/Low Difference in Indoor/Indoor Section (h)	39 ft [12 m] or less

■ **Selecting the Refrigerant Branch Kit**

Please select branching kit, which is sold separately, from the table below. (The kit comprises sets for use with liquid pipes and for use with gas pipes.)

Branch header (4 branches)	Branch header (8 branches)
CMY-Y64-G-E	CMY-Y68-G-E

■ **Select Each Section of Refrigerant Piping**

- (1) Section From Outdoor Unit to First Branch (A)  
(2) Sections From Branch to Indoor Unit (a,b,c,d)

Select the size from the right table.

(1) Refrigerant Piping Diameter In Section From Outdoor Unit to First Branch (Outdoor Unit Piping Diameter)

Model	Piping Diameter (in [mm])
PUMY-P36,48	Liquid Line $\phi 3/8$ [9.52]
	Gas Line $\phi 5/8$ [15.88]

(2) Refrigerant Piping Diameter In Section From Branch to Indoor Unit (Indoor Unit Piping Diameter)

Model number	Piping Diameter (in [mm])
18 or lower	Liquid Line $\phi 1/4$ [6.35]
	Gas Line $\phi 1/2$ [12.7]
24 to 54	Liquid Line $\phi 3/8$ [9.52]
	Gas Line $\phi 5/8$ [15.88]

■ **Additional refrigerant charge**

- Refrigerant of 6.6 lbs [3 kg] equivalent to 165 ft [50 m] total extended piping length is already included when the outdoor unit is shipped. Thus, if the total extended piping length is 165 ft [50 m] or less, there is no need to charge with additional refrigerant.
- If the total extended piping length exceeds 165 ft [50 m], calculate the required additional refrigerant charge using the procedure shown on the right.
- If the calculated additional refrigerant charge is a negative amount, do not charge with any refrigerant.

<Additional Charge>

Additional refrigerant charge	=	Liquid pipe size Total length of $\phi 3/8" \times 0.041 \text{ lbs}$ [9.52 $\times$ 0.06 kg]	+	Liquid pipe size Total length of $\phi 1/4" \times 0.016 \text{ lbs}$ [6.35 $\times$ 0.024 kg]	-	Refrigerant amount for outdoor unit
(lb) [kg]		(ft) $\times$ 0.041 (lb/ft), [m] $\times$ 0.06 [kg/m]		(ft) $\times$ 0.016 (lb/ft), [m] $\times$ 0.024 [kg/m]		6.6 lbs [3.0kg]

<Example>

Outdoor model : P48

Indoor

1 : P24	A : $\phi 3/8"$ [9.52]	98 ft [30 m]	a : $\phi 3/8"$ [9.52]	49 ft [15 m]	} At the conditions below:
2 : P15			b : $\phi 1/4"$ [6.35]	33 ft [10 m]	
3 : P08			c : $\phi 1/4"$ [6.35]	33 ft [10 m]	
4 : P06			d : $\phi 1/4"$ [6.35]	66 ft [20 m]	

The total length of each liquid line is as follows;

$\phi 9.52$  :  $A + a = 98 \text{ ft} + 49 \text{ ft} = 147 \text{ ft}$  [30 m + 15 m = 45 m]

$\phi 6.35$  :  $b + c + d = 33 \text{ ft} + 33 \text{ ft} + 66 \text{ ft} = 132 \text{ ft}$  [10 m + 10 m + 20 m = 40 m]

<Calculation example>

Additional

refrigerant charge =  $147 \text{ ft} \times 0.041 \text{ lbs} + 132 \text{ ft} \times 0.016 \text{ lbs} - 6.6 \text{ lbs} = 1.54 \text{ lbs}$

=  $[45 \text{ m} \times 0.06 \text{ kg} + 40 \text{ m} \times 0.024 \text{ kg} - 3.0 \text{ kg} = 0.7 \text{ kg}$  (rounded up)]

**Method of Combined Branching of Lines and Headers**  
 Connection Examples  
 (Connecting to 5 Indoor Units)

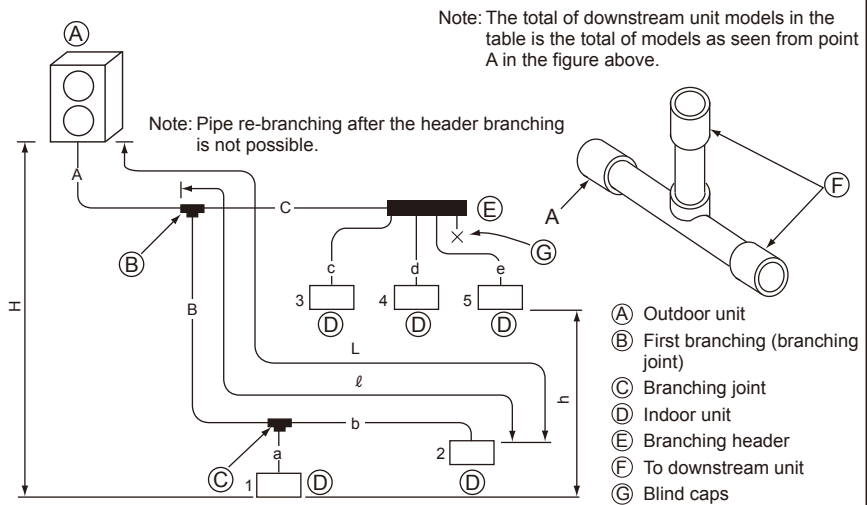

Permissible Length	Total Piping Length	A+B+C+a+b+c+d+e is 394 ft [120 m] or less
	Farthest Piping Length (L)	A+B+b is 262 ft [80 m] or less
	Farthest Piping Length After First Branch (ℓ)	B+b is 100 ft [30 m] or less
Permissible High/Low Difference	High/Low Difference in Indoor/Outdoor Section (H)	164 ft [50 m] or less (If the outdoor unit is lower, 70 ft [20 m] or less)
	High/Low Difference in Indoor/Indoor Section (h)	39 ft [12 m] or less

■ **Selecting the Refrigerant Branch Kit**

Please select branching kit, which is sold separately, from the table below.  
 (The kit comprises sets for use with liquid pipes and for use with gas pipes.)

Branch Joint	Branch Header (4 branches)	Branch Header (8 branches)
CMY-Y62-G-E	CMY-Y64-G-E	CMY-Y68-G-E

■ **Select Each Section of Refrigerant Piping**

- (1) Section From Outdoor Unit to First Branch (A)
- (2) Sections From Branch to Indoor Unit (a,b,c,d,e)
- (3) Section From Branch to Branch (B,C)

Select the size from the right table.

(1) Refrigerant Piping Diameter In Section From Outdoor Unit to First Branch (Outdoor Unit Piping Diameter)	(2) Refrigerant Piping Diameter In Section From Branch to Indoor Unit (Indoor Unit Piping Diameter)													
<table border="1"> <thead> <tr> <th>Model</th> <th>Piping Diameter (in [mm])</th> </tr> </thead> <tbody> <tr> <td rowspan="2">PUMY-P36, 48</td> <td>Liquid Line φ3/8 [9.52]</td> </tr> <tr> <td>Gas Line φ5/8 [15.88]</td> </tr> </tbody> </table>	Model	Piping Diameter (in [mm])	PUMY-P36, 48	Liquid Line φ3/8 [9.52]	Gas Line φ5/8 [15.88]	<table border="1"> <thead> <tr> <th>Model number</th> <th>Piping Diameter (in [mm])</th> </tr> </thead> <tbody> <tr> <td rowspan="2">18 or lower</td> <td>Liquid Line φ1/4 [6.35]</td> </tr> <tr> <td>Gas Line φ1/2 [12.7]</td> </tr> <tr> <td rowspan="2">24 to 54</td> <td>Liquid Line φ3/8 [9.52]</td> </tr> <tr> <td>Gas Line φ5/8 [15.88]</td> </tr> </tbody> </table>	Model number	Piping Diameter (in [mm])	18 or lower	Liquid Line φ1/4 [6.35]	Gas Line φ1/2 [12.7]	24 to 54	Liquid Line φ3/8 [9.52]	Gas Line φ5/8 [15.88]
Model	Piping Diameter (in [mm])													
PUMY-P36, 48	Liquid Line φ3/8 [9.52]													
	Gas Line φ5/8 [15.88]													
Model number	Piping Diameter (in [mm])													
18 or lower	Liquid Line φ1/4 [6.35]													
	Gas Line φ1/2 [12.7]													
24 to 54	Liquid Line φ3/8 [9.52]													
	Gas Line φ5/8 [15.88]													
(3) Refrigerant Piping Diameter In Section From Branch to Branch														
<table border="1"> <thead> <tr> <th>Liquid Line (in [mm])</th> <th>Gas Line (in [mm])</th> </tr> </thead> <tbody> <tr> <td>φ3/8 [9.52]</td> <td>φ5/8 [15.88]</td> </tr> </tbody> </table>	Liquid Line (in [mm])	Gas Line (in [mm])	φ3/8 [9.52]	φ5/8 [15.88]										
Liquid Line (in [mm])	Gas Line (in [mm])													
φ3/8 [9.52]	φ5/8 [15.88]													

■ **Additional refrigerant charge**

- Refrigerant of 6.6 lbs [3 kg] equivalent to 165 ft [50 m] total extended piping length is already included when the outdoor unit is shipped. Thus, if the total extended piping length is 165 ft [50 m] or less, there is no need to charge with additional refrigerant.
- If the total extended piping length exceeds 165 ft [50 m], calculate the required additional refrigerant charge using the procedure shown on the right.
- If the calculated additional refrigerant charge is a negative amount, do not charge with any refrigerant.

<Additional Charge>

Additional refrigerant charge	=	Liquid pipe size Total length of φ3/8" × 0.041 lbs [9.52 × 0.06 kg]	+	Liquid pipe size Total length of φ1/4" × 0.016 lbs [6.35 × 0.024 kg]	-	Refrigerant amount for outdoor unit
(lb) [kg]		(ft) × 0.041 (lb/ft), [m] × 0.06 [kg/m]		(ft) × 0.016 (lb/ft), [m] × 0.024 [kg/m]		6.6 lbs [3.0kg]

<Example>  
 Outdoor model : P48  
 Indoor

1 : P24	A : φ3/8" [9.52]	33 ft [10 m]	a : φ3/8" [9.52]	49 ft [15 m]	} At the conditions below:
2 : P15	B : φ3/8" [9.52]	33 ft [10 m]	b : φ1/4" [6.35]	33 ft [10 m]	
3 : P08	C : φ3/8" [9.52]	33 ft [10 m]	c : φ1/4" [6.35]	33 ft [10 m]	
4 : P06			d : φ1/4" [6.35]	33 ft [10 m]	
5 : P06			e : φ1/4" [6.35]	33 ft [10 m]	

The total length of each liquid line is as follows;  
 φ9.52 : A + B + C + a = 33 ft + 33 ft + 33 ft + 49 ft = 148 ft [10 m + 10 m + 10 m + 15 m = 45 m]  
 φ6.35 : b + c + d + e = 33 ft + 33 ft + 33 ft + 33 ft = 132 ft [10 m + 10 m + 10 m + 10 m = 40 m]

<Calculation example>  
 Additional refrigerant charge = 148 ft × 0.041 lbs + 132 ft × 0.016 lbs – 6.6 lbs = 1.58 lbs  
 = [45 m × 0.06 kg + 40 m × 0.024 kg – 3.0 kg = 0.7kg (rounded up)]

## 11-2. REFRIGERANT PIPE AIRTIGHT TESTING METHOD

- (1) Connect the testing tools.
  - Make sure the stop valves ① ② are closed and do not open them.
  - Add pressure to the refrigerant lines through the service port ③ of the liquid stop valve ① and the stop valve ②.
- (2) Do not add pressure to the specified pressure all at once; add pressure little by little.
  - ① Pressurize to 0.5 MPa (5 kgf/cm<sup>2</sup>G), wait 5 minutes, and make sure the pressure does not decrease.
  - ② Pressurize to 1.5 MPa (15 kgf/cm<sup>2</sup>G), wait 5 minutes, and make sure the pressure does not decrease.
  - ③ Pressurize to 4.15 MPa (41.5 kgf/cm<sup>2</sup>G) and measure the surrounding temperature and refrigerant pressure.
- (3) If the specified pressure holds for about one day and does not decrease, the pipes have passed the test and there are no leaks.
  - If the surrounding temperature changes by 1°C, the pressure will change by about 0.01 MPa (0.1 kgf/cm<sup>2</sup>G). Make the necessary corrections.
- (4) If the pressure decreases in steps (2) or (3), there is a gas leak. Look for the source of the gas leak.

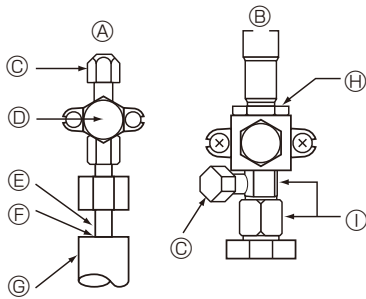

- ① Stop valve <Liquid side>
- ② Stop valve <Gas side>
- ③ Service port
- ④ Open/Close section
- ⑤ Local pipe
- ⑥ Sealed, same way for gas side
- ⑦ Pipe cover
- ⑧ Do not use a wrench here.  
Refrigerant leakage may result.
- ⑨ Use 2 wrenches here.

### 11-3. PRECAUTIONS AGAINST REFRIGERANT LEAKAGE

The installer and system specialist shall secure safety against leakage according to local regulations or standards. The following standards may be applicable if local regulations are not available.

#### 11-3-1. Introduction

R410A refrigerant of this air conditioner is non-toxic and non-flammable but leaking of large amount from an indoor unit into the room where the unit is installed may be deleterious. To prevent possible injury, the rooms should be large enough to keep the R410A concentration specified by ISO 5149-1 as follows.

Maximum concentration  
 Maximum refrigerant concentration of R410A of a room is 0.44 kg/m<sup>3</sup> accordance with ISO 5149-1.  
 To facilitate calculation, the maximum concentration is expressed in units of kg/m<sup>3</sup> ( kg of R410A per m<sup>3</sup>)

Maximum concentration of R410A: 0.027 lb/ft<sup>3</sup> [0.44 kg/m<sup>3</sup>]

(ISO 5149-1)

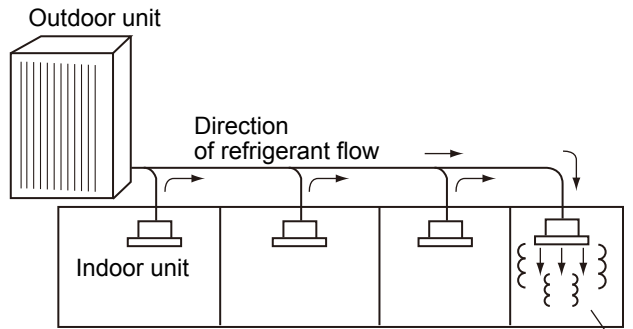

All refrigerant of this system will leak out to this room if there is leakage at this indoor unit.

#### 11-3-2. Confirming procedure of R410A concentration

Follow (1) to (3) to confirm the R410A concentration and take appropriate treatment, if necessary.

##### (1) Calculate total refrigerant amount by each refrigerant system.

**Total refrigerant amount is precharged refrigerant amount at ex-factory plus additional charged amount at field installation.**

Note:  
 When a single refrigeration system consists of several independent refrigeration circuit, figure out the total refrigerant amount by adding each independent refrigerant circuit.

##### (2) Calculate room volumes (ft<sup>3</sup>[m<sup>3</sup>]) and find the room with the smallest volume

The part with  represents the room with the smallest volume.

##### (a) Situation in which there are no partitions

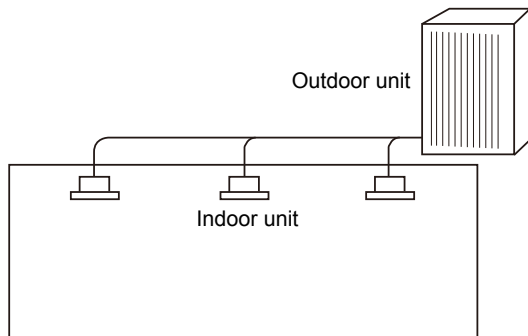

##### (b) There are partitions, but there are openings that allow the effective mixing of air.

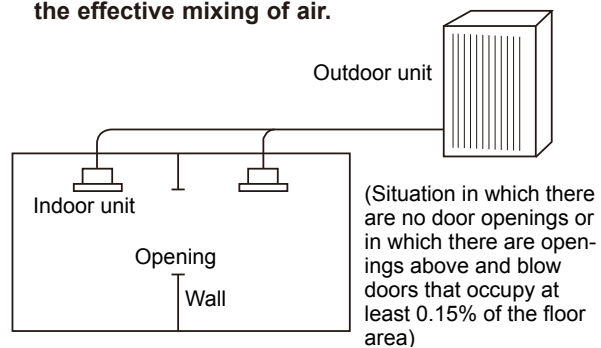

##### (c) If the smallest room has mechanical ventilation

**apparatus that is linked to a household gas detection and alarm device, the calculations should be performed for the second smallest room.**

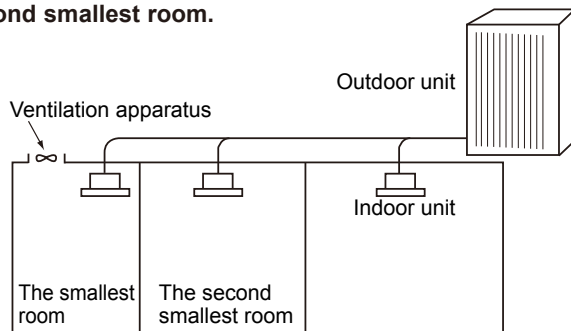

##### (3) Use the results of calculations (1) and (2) to calculate the refrigerant concentration:

$$\frac{\text{Total refrigerant in the refrigerating unit (lb [kg])}}{\text{The smallest room in which an indoor unit has been installed (ft}^3 \text{ [m}^3\text{])}} \leq \text{maximum concentration (lb/ft}^3 \text{ [kg/m}^3\text{])}$$

Maximum concentration of R410A: 0.027 lb/ft<sup>3</sup> [0.44 kg/m<sup>3</sup>]

If the calculation results do not exceed the maximum concentration, perform the same calculations for the larger second and third room, etc., until it has been determined that nowhere will the maximum concentration be exceeded.

## 11-4. REFRIGERANT COLLECTING (PUMP DOWN)

Perform the following procedures to collect the refrigerant when moving the indoor unit or the outdoor unit.

- ① Turn off the circuit breaker.
- ② Connect the low pressure side of the gauge manifold to the service port of the gas side stop valve.
- ③ Close the liquid stop valve.
- ④ Supply power (circuit breaker).
  - Start-up of the indoor-outdoor communication takes about 3 minutes after the power (circuit breaker) is turned on. Start the pump-down operation 3 to 4 minutes after the power (circuit breaker) is turned ON.
- ⑤ Perform the test run for cooling operation (SW3-1: ON and SW3-2: OFF). The compressor (outdoor unit) and ventilators (indoor and outdoor units) start operating and test run for cooling operation begins. After the cooling operation has been carried out for approximately 5 minutes, set the outdoor service switch SW2-4 (pump down switch) from OFF to ON.
  - Do not continue to operate for a long time with the switch SW2-4 set to ON. Make sure to switch it to OFF after pump down is completed.
  - Only set the SW3-1 and SW3-2 to ON if the unit is stopped. However, even if the unit is stopped and the SW3-1 and SW3-2 are set to ON less than 3 minutes after the compressor stops, the refrigerant collecting operation cannot be performed. Wait until compressor has been stopped for 3 minutes and then set the SW3-1 and SW3-2 to ON again.
- ⑥ Fully close the gas stop valve when the pressure reading on the gauge drops 0.05–0.00 MPa (approx. 0.5–0.0 kgf/cm<sup>2</sup>).
- ⑦ Stop the air conditioner operation (SW3-1: OFF and SW3-2: OFF). Set the outdoor service switch SW2-4 from ON to OFF.
- ⑧ Turn off the power supply (circuit breaker).
  - If too much refrigerant has been added to the air conditioner system, the pressure may not drop to 0.5 kgf/cm<sup>2</sup>. If this occurs, use a refrigerant collecting device to collect all of the refrigerant in the system, and then recharge the system with the correct amount of refrigerant after the indoor and outdoor units have been relocated.

### **⚠Warning:**

**When pumping down the refrigerant, stop the compressor before disconnecting the refrigerant pipes.**

**The compressor may burst and cause injury if any foreign substance, such as air, etc. enters the system.**

**OUTDOOR UNIT:**

**PUMY-P36NHMU(-BS)**

**PUMY-P36NHMUR1(-BS)**

**PUMY-P36NHMUR4(-BS)**

**PUMY-P48NHMU(-BS)**

**PUMY-P48NHMU<sub>1</sub>(-BS)**

**PUMY-P48NHMU<sub>2</sub>(-BS)**

**PUMY-P48NHMUR3(-BS)**

**PUMY-P48NHMUR4(-BS)**

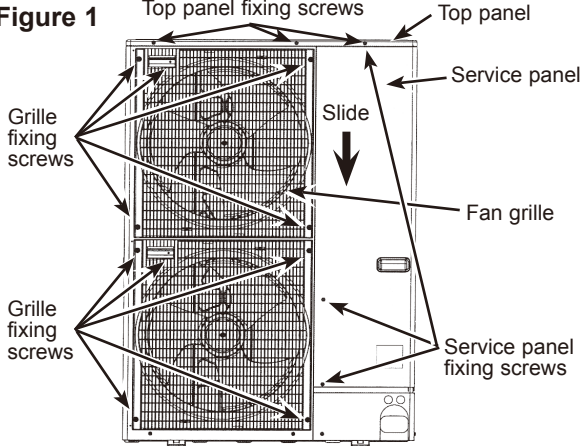
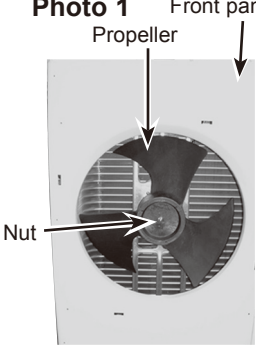
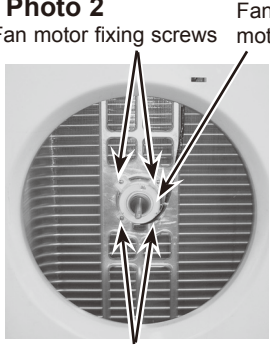
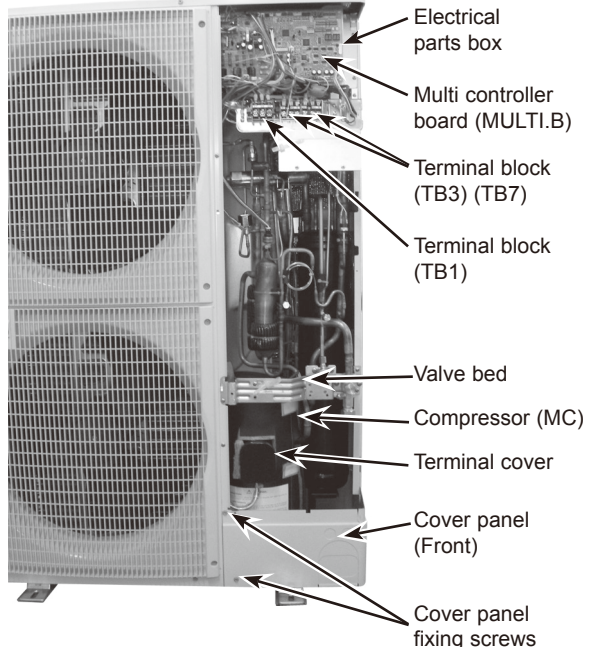
OPERATING PROCEDURE	PHOTOS & ILLUSTRATION
<p><b>1. Removing the service panel and top panel</b></p> <p>(1) Remove 3 service panel fixing screws (5 × 12) and slide the hook on the right downward to remove the service panel.</p> <p>(2) Remove screws (3 for front, 3 for rear/5 × 12) of the top panel and remove it.</p>	<p><b>Figure 1</b></p> 
<p><b>2. Removing the fan motor (MF1, MF2)</b></p> <p>(1) Remove the service panel. (See Figure 1)</p> <p>(2) Remove the top panel. (See Figure 1)</p> <p>(3) Remove 5 fan grille fixing screws (5 × 12) to detach the fan grille. (See Figure 1)</p> <p>(4) Remove a nut (for right handed screw of M6) to detach the propeller. (See Photo 1.)</p> <p>(5) Disconnect the connectors, CNF1 and CNF2 on Multi controller board in electrical parts box.</p> <p>(6) Remove 4 fan motor fixing screws (5 × 25) to detach the fan motor. (See Photo 2)</p>	<p><b>Photo 1</b></p>  <p><b>Photo 2</b></p> 
<p><b>3. Removing the electrical parts box</b></p> <p>(1) Remove the service panel. (See Figure 1)</p> <p>(2) Remove the top panel. (See Figure 1)</p> <p>(3) Disconnect the connecting wire from terminal block.</p> <p>(4) Remove all the following connectors from Multi controller board; fan motor, thermistor &lt;Outdoor pipe&gt;, thermistor &lt;Discharge/Compressor&gt;, thermistor &lt;Low pressure saturated temp&gt;, thermistor &lt;Outdoor&gt;, high pressure switch, high pressure sensor, low pressure switch, 4-way valve coil and bypass valve coil.</p> <p>Pull out the disconnected wire from the electrical parts box.</p> <p>&lt;Diagram symbol in the connector housing&gt;</p> <ul style="list-style-type: none"> <li>• Fan motor (CNF1, CNF2)</li> <li>• Thermistor &lt;Outdoor pipe&gt; (TH3)</li> <li>• Thermistor &lt;Discharge/Compressor&gt; (TH4)</li> <li>• Thermistor &lt;Low pressure saturated temp, Outdoor&gt; (TH6/7)</li> <li>• High pressure switch (63H)</li> <li>• High pressure sensor (63HS)</li> <li>• Low pressure switch (63L)</li> <li>• Solenoid valve coil &lt;Four-way valve&gt; (21S4)</li> <li>• Solenoid valve coil &lt;Bypass valve&gt; (SV1)</li> </ul> <p>(5) Remove the terminal cover and disconnect the compressor lead wire.</p>	<p><b>Photo 3</b></p> 

From the previous page.

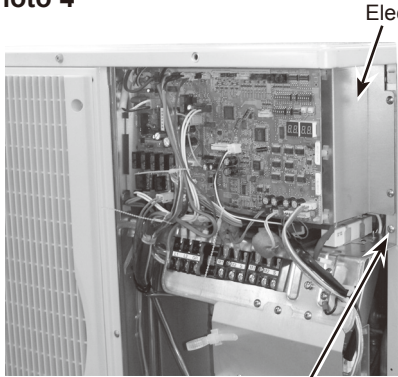
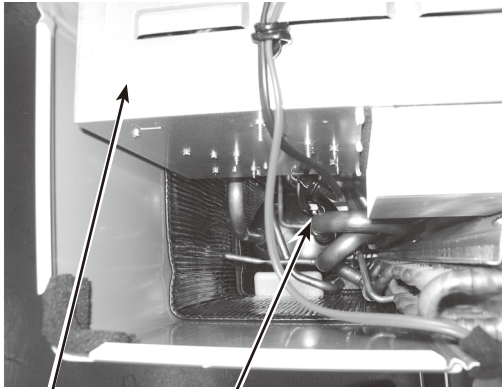
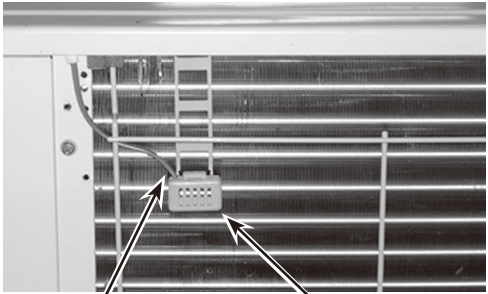
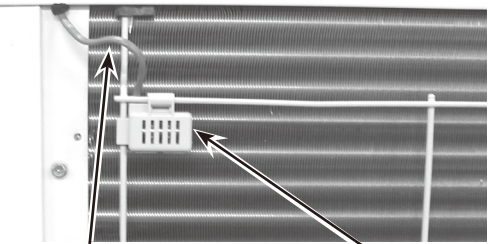
OPERATING PROCEDURE	PHOTOS
<p>(6) Remove electrical parts box fixing screw (4 × 10) and detach the electrical parts box by pulling it upward. The electrical parts box is fixed with 2 hooks on the left and 1 hook on the right.</p>	<p><b>Photo 4</b></p>  <p>Electrical parts box</p> <p>Electrical parts box fixing screw</p>
<p><b>4. Removing the thermistor &lt;Low pressure saturated temp.&gt; (TH6)</b></p> <ol style="list-style-type: none"> <li>(1) Remove the service panel. (See Figure 1)</li> <li>(2) Remove the top panel. (See Figure 1)</li> <li>(3) Disconnect the connector, TH6 and TH7 (red), on the Multi controller board in the electrical parts box.</li> <li>(4) Loosen the wire clamps on top of the electrical parts box.</li> <li>(5) Pull out the thermistor &lt;Low pressure saturated temp.&gt; (TH6) from the sensor holder.</li> </ol> <p><b>Note:</b> In case of replacing thermistor &lt;Low pressure saturated temp.&gt; (TH6), replace it together with thermistor &lt;Outdoor&gt; (TH7) since they are combined together. Refer to No.5 below to remove thermistor &lt;Outdoor&gt;.</p>	<p><b>Photo 5</b></p>  <p>Electrical parts box</p> <p>Thermistor &lt;TH6&gt;</p>
<p><b>5. Removing the thermistor &lt;Outdoor&gt; (TH7)</b></p> <ol style="list-style-type: none"> <li>(1) Remove the service panel. (See Figure 1)</li> <li>(2) Remove the top panel. (See Figure 1)</li> <li>(3) Disconnect the connector TH6 and TH7 (red) on the Multi controller board in the electrical parts box.</li> <li>(4) Loosen the wire clamps on top of the electrical parts box. (See Photo 4)</li> <li>(5) Pull out the thermistor &lt;Outdoor&gt; (TH7) from the sensor holder.</li> </ol> <p><b>Note:</b> In case of replacing thermistor &lt;Outdoor&gt; (TH7), replace it together with thermistor &lt;Low pressure saturated temp.&gt; (TH6), since they are combined together. Refer to No.4 above to remove thermistor &lt;Low pressure saturated temp.&gt;.</p>	<p><b>Photo 6</b></p> <p><b>PUMY-P48NHMU<sup>(1)</sup></b></p>  <p>Lead wire of thermistor &lt;Outdoor&gt; (TH7)</p> <p>Sensor holder &lt;Outdoor&gt; (TH7)</p> <p><b>PUMY-P36NHMU(R1/R4)/P48NHMU<sup>(2)</sup>, (R3/R4)</b></p>  <p>Lead wire of thermistor &lt;Outdoor&gt; (TH7)</p> <p>Sensor holder</p>

## OPERATING PROCEDURE

### 6. Removing the thermistor <Outdoor pipe> (TH3) and thermistor <Discharge/Compressor> (TH4)

- (1) Remove the service panel. (See Figure 1)
- (2) Disconnect the connectors, TH3 (white) and TH4 (white), on the Multi controller board in the electrical parts box.
- (3) Loosen the clamp for the lead wire in the rear of the electrical parts box.
- (4) Pull out the thermistor <Outdoor pipe> (TH3) and thermistor <Discharge/Compressor> (TH4) from the sensor holder.

## PHOTOS

Photo 7

Thermistor  
<Outdoor pipe>  
(TH3)

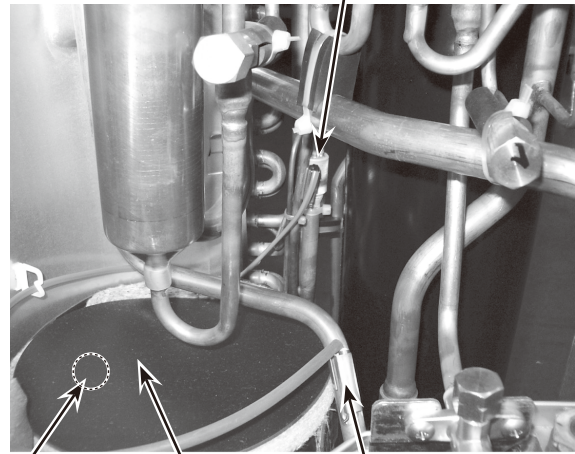

Thermistor  
<Compressor>  
(TH4)

Compressor  
(MC)

Thermistor  
<Discharge>  
(TH4)

### 7. Removing the 4-way valve coil (21S4)

- (1) Remove the service panel. (See Figure 1)
- (2) Remove the top panel. (See Figure 1)

#### [Removing the 4-way valve coil]

- (3) Remove 4-way valve solenoid coil fixing screw (M4 × 6).
- (4) Remove the 4-way valve coil by sliding the coil toward you.
- (5) Disconnect the connector 21S4 (green) on the Multi controller board in the electrical parts box.

Photo 8

4-way valve coil  
(21S4)

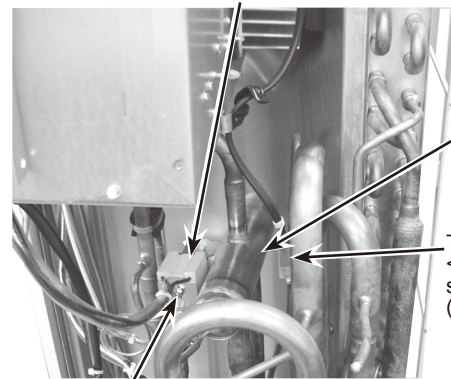

4-way  
valve

Thermistor  
<Low pressure  
saturated temp.>  
(TH6)

4-way valve coil  
fixing screw

### 8. Removing the 4-way valve

- (1) Remove the service panel. (See Figure 1)
- (2) Remove the top panel. (See Figure 1)
- (3) Remove 3 valve bed fixing screws (4 × 10) and 4 ball valve and stop valve fixing screws (5 × 16) and then remove the valve bed.
- (4) Remove 5 right side panel fixing screws (5 × 12) in the rear of the unit and then remove the right side panel.
- (5) Remove the 4-way valve coil. (See Photo 8)
- (6) Recover refrigerant.
- (7) Remove the welded part of 4-way valve.

**Note 1:** Recover refrigerant without spreading it in the air.

**Note 2:** The welded part can be removed easily by removing the right side panel.

**Note 3:** When installing the 4-way valve, cover it with a wet cloth to prevent it from heating ([248°F] 120°C or more), then braze the pipes so that the inside of pipes are not oxidized.

## OPERATING PROCEDURE

### 9. Removing bypass valve coil (SV1) and bypass valve

- (1) Remove the service panel. (See Figure 1)
- (2) Remove the top panel. (See Figure 1)
- (3) Remove 5 right side panel fixing screws (5 × 12) in the rear of the unit and remove the right side panel.
- (4) Remove the bypass valve coil fixing screw (M4 × 6).
- (5) Remove the bypass valve coil by sliding the coil upward.
- (6) Disconnect the connector SV1 (white) on the Multi controller circuit board in the electrical parts box.
- (7) Recover refrigerant.
- (8) Remove the welded part of bypass valve.

**Note 1:** Recover refrigerant without spreading it in the air.

**Note 2:** The welded part can be removed easily by removing the right side panel.

### 10. Removing the high pressure switch (63H) and low pressure switch (63L)

- (1) Remove the service panel. (See Figure 1)
- (2) Remove the top panel. (See Figure 1)
- (3) Remove the electrical parts box. (See Photo 4)
- (4) Remove 5 right side panel fixing screws (5 × 12) in the rear of the unit and remove the right side panel.
- (5) Pull out the lead wire of high pressure switch and low pressure switch.
- (6) Recover refrigerant.
- (7) Remove the welded part of high pressure switch and low pressure switch.

**Note 1:** Recover refrigerant without spreading it in the air.

**Note 2:** The welded part can be removed easily by removing the right side panel.

**Note 3:** When installing the high pressure switch and low pressure switch, cover them with a wet cloth to prevent them from heating ([212°F] 100°C or more), then braze the pipes so that the inside of pipes are not oxidized.

### 11. Removing the high pressure sensor (63HS)

- (1) Remove the service panel. (See Figure 1)
- (2) Remove the top panel. (See Figure 1)
- (3) Remove the electrical parts box. (See Photo 4)
- (4) Remove 5 right side panel fixing screws (5 × 12) in the rear of the unit and remove the right side panel.
- (5) Pull out the lead wire of high pressure sensor.
- (6) Recover refrigerant.
- (7) Remove the welded part of high pressure sensor.

**Note 1:** Recover refrigerant without spreading it in the air.

**Note 2:** The welded part can be removed easily by removing the right side panel.

**Note 3:** When installing the high pressure sensor, cover it with a wet cloth to prevent it from heating ([212°F] 100°C or more), then braze the pipes so that the inside of pipes are not oxidized.

## PHOTOS

Photo 9

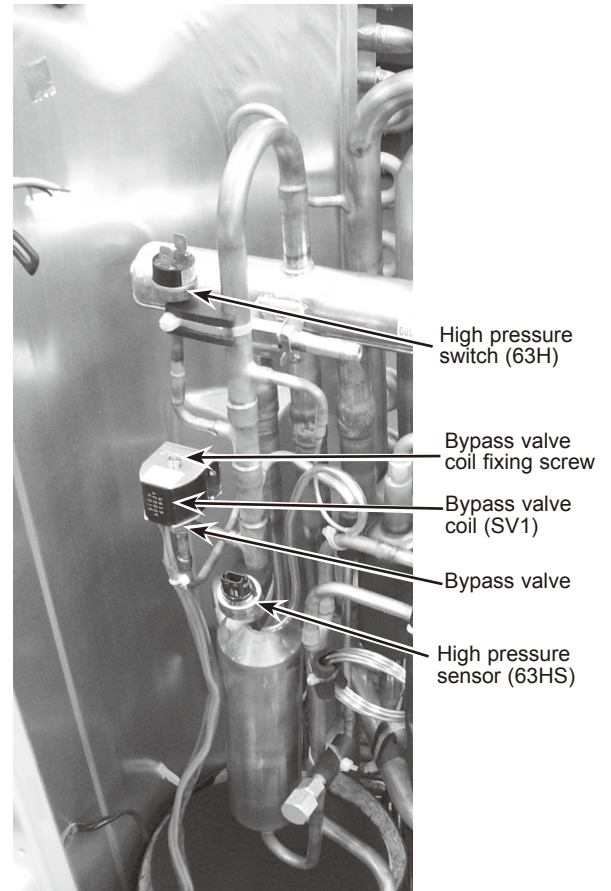

Photo 10



## OPERATING PROCEDURE

### 12. Removing the compressor (MC)

- (1) Remove the service panel. (See Figure 1)
- (2) Remove the top panel. (See Figure 1)
- (3) Remove 2 front cover panel fixing screws (5 × 12) and remove the front cover panel. (See Photo 3)
- (4) Remove 2 back cover panel fixing screws (5 × 12) and remove the back cover panel.
- (5) Remove the electrical parts box. (See Photo 3)
- (6) Remove 3 valve bed fixing screws (4 × 10) and 4 ball valve and stop valve fixing screws (5 × 16) and then remove the valve bed.
- (7) Remove 4 right side panel fixing screws (5 × 12) in the rear of the unit and then remove the right side panel.
- (8) Remove 3 separator fixing screws (4 × 10) and remove the separator.
- (9) Recover refrigerant.
- (10) Remove the 3 points of the motor for compressor fixing nut using a spanner or a monkey wrench.
- (11) Remove the welded pipe of motor for compressor inlet and outlet and then remove the compressor.

**Note: Recover refrigerant without spreading it in the air.**

## PHOTOS

Photo 11

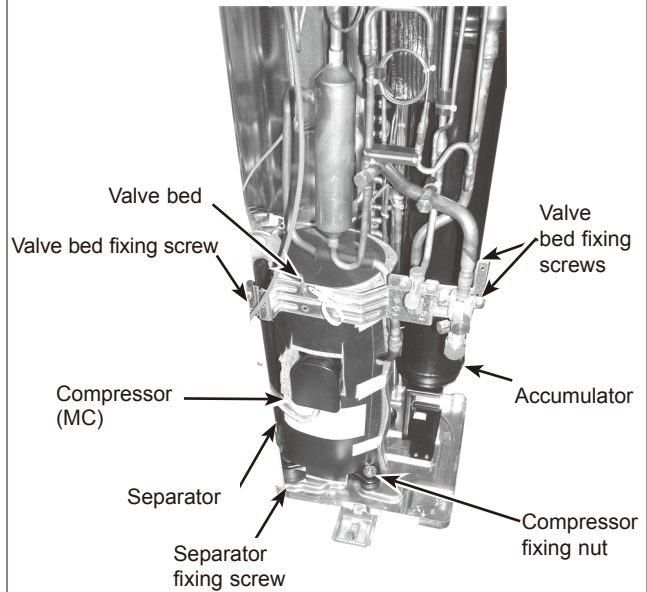

### 13. Removing the accumulator

- (1) Remove the service panel. (See Figure 1)
- (2) Remove the top panel. (See Figure 1)
- (3) Remove 2 front cover panel fixing screws (5 × 12) and remove the front cover panel. (See Photo 3)
- (4) Remove 2 back cover panel fixing screws (5 × 12) and remove the back cover panel.
- (5) Remove the electrical parts box. (See Photo 3)
- (6) Remove 3 valve bed fixing screws (4 × 10) and 4 ball valve and stop valve fixing screws (5 × 16) and then remove the valve bed.
- (7) Remove 4 right side panel fixing screws (5 × 12) in the rear of the unit and then remove the right side panel.
- (8) Recover refrigerant.
- (9) Remove 4 welded pipes of power receiver inlet and outlet.
- (10) Remove 2 receiver leg fixing screws (4 × 10). (See Photo 13)

**Note: Recover refrigerant without spreading it in the air.**

Photo 12

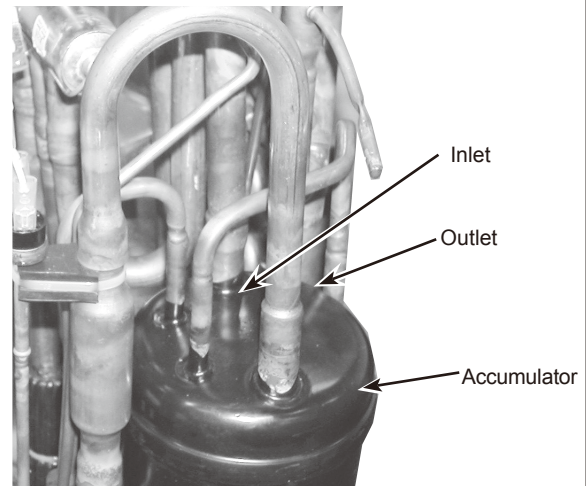
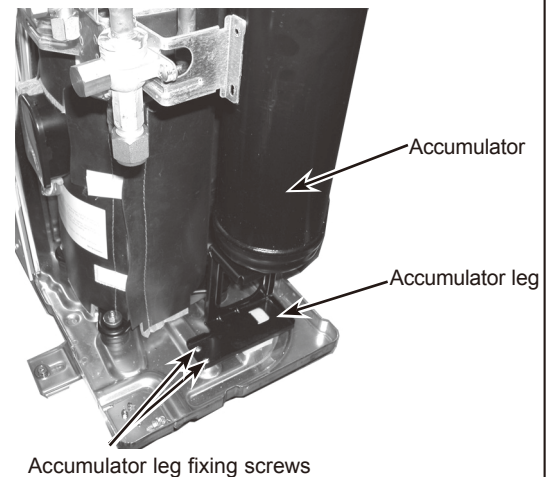

Photo 13



# 13

## PARTS LIST (non-RoHS compliant)

### 13-1. STRUCTURAL PARTS

PUMY-P48NHMU

PUMY-P48NHMU-BS

PUMY-P48NHMU<sub>1</sub>

PUMY-P48NHMU<sub>1</sub>-BS

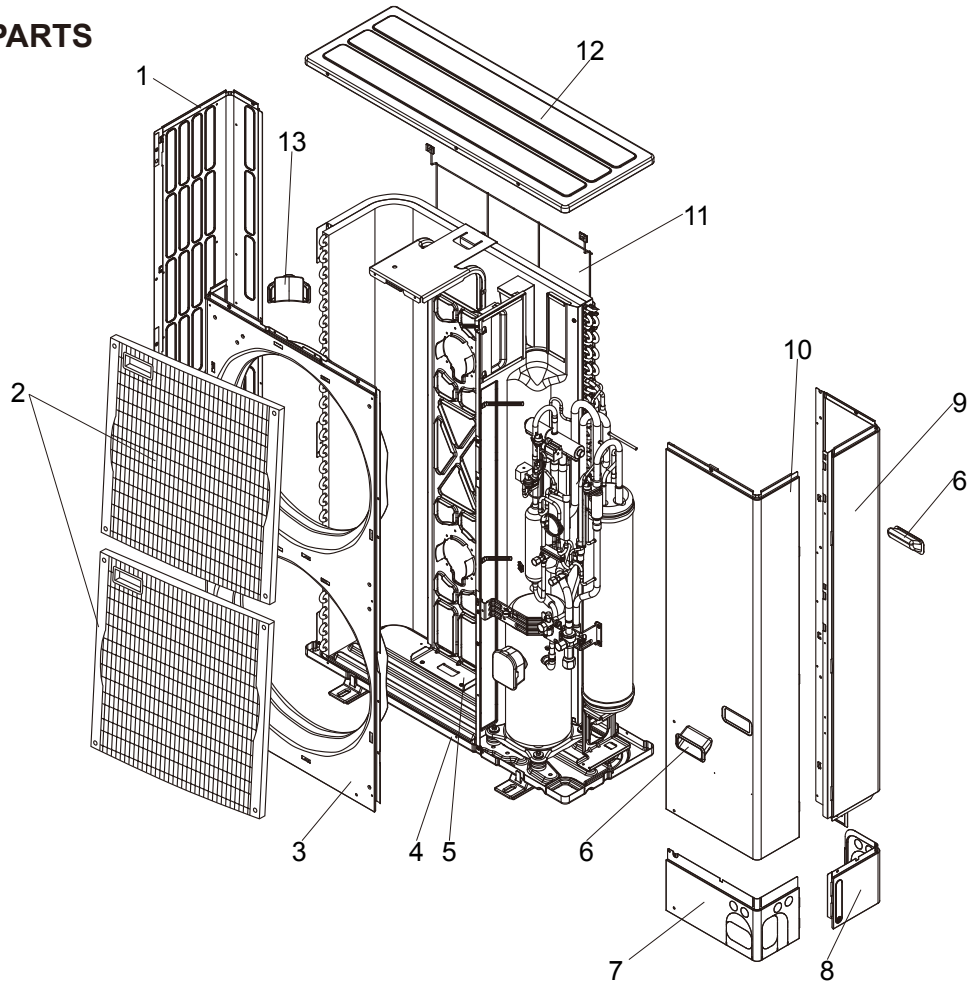

Note: Parts of PUMY-P48NHMU are set as the same service parts as PUMY-P48NHMU-BS.

No.	Parts No.	Parts Name	Specification	Q'ty/unit		Remarks (Drawing No.)	Wiring Diagram Symbol	Recom- mended Q'ty
				PUMY-P48 NHMU(-BS)	PUMY-P48 NHMU <sub>1</sub> (-BS)			
1	R01 E04 662	SIDE PANEL (L)		1	1			
2	T7W E02 691	FAN GRILLE		2	2			
3	T7W E04 667	FRONT PANEL		1	1			
4	R01 E18 686	BASE ASSY		1				
	R01 E26 686	BASE ASSY			1			
5	R01 E19 130	MOTOR SUPPORT		1	1			
6	R01 30L 655	HANDLE		2	2			
7	T7W E01 658	COVER PANEL (FRONT)		1		Including CONDUIT PLATE		
	R01 E14 658	COVER PANEL (FRONT)			1	Including CONDUIT PLATE		
8	T7W E00 658	COVER PANEL (REAR)		1		Including CONDUIT PLATE		
	R01 E05 658	COVER PANEL (REAR)			1	Including CONDUIT PLATE		
9	T7W E16 661	SIDE PANEL (R)		1	1			
10	T7W E06 668	SERVICE PANEL		1	1			
11	R01 E01 698	REAR GUARD		1	1			
12	R01 E06 641	TOP PANEL		1	1			
13	R01 E00 655	HANDLE		1	1			

# PARTS LIST (non-RoHS compliant)

## 13-2. FUNCTIONAL PARTS

PUMY-P48NHMU      PUMY-P48NHMU<sub>1</sub>  
PUMY-P48NHMU-BS   PUMY-P48NHMU<sub>1</sub>-BS

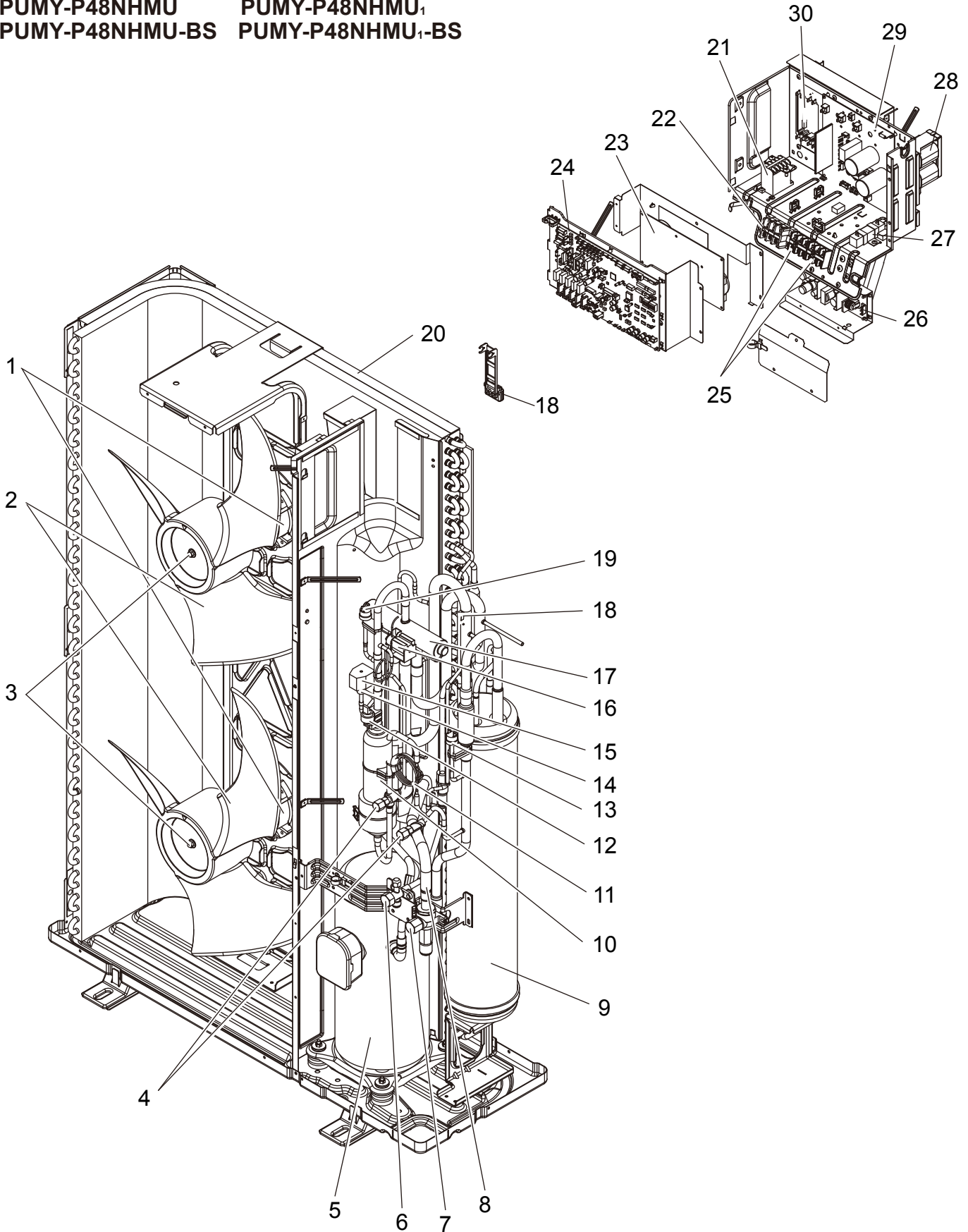

# PARTS LIST (non-RoHS compliant)

Parts numbers that are circled are not shown in the figure.

No.	Parts No.	Parts Name	Specification	Q'ty/unit	Remarks (Drawing No.)	Wining Diagram Symbol	Recom- mended Q'ty
				PUMY-P48NHMU <sup>(1)</sup> PUMY-P48NHMU <sup>(1)</sup> -BS			
1	R01 E44 221	FAN MOTOR		2		MF1,2	
2	R01 E01 115	PROPELLER FAN		2			
3	R01 E02 097	NUT		2			
4	T7W E07 413	CHARGE PLUG		2			
5	T97 410 742	COMPRESSOR	ANB33FDCMT Including RUBBER MOUNT	1		MC	
6	T7W E04 410	STOP VALVE	3/8	1			
7	T7W E06 411	BALL VALVE	5/8	1			
8	R01 E03 450	STRAINER		1			
9	R01 E35 440	ACCUMULATOR		1			
10	T7W E02 490	OIL SEPARATOR		1			
11	R01 E22 425	CAPILLARY TUBE	$\phi 2.5 \times \phi 0.8 \times 1000\text{mm}$ [ $\phi(3/32) \times \phi(1/32) \times L(39-1/2)$ ]inch	1			
12	T7W E04 208	H.P SENSOR		1		63HS	
13	R01 25T 209	LOW PRESSURE SWITCH		1		63L	
14	T7W E03 428	BYPASS VALVE		1			
15	T7W E17 242	SOLENOID COIL <BYPASS VALVE>		1		SV1	
16	T7W E18 242	SOLENOID COIL <4-WAY VALVE>		1		21S4	
17	T7W E05 403	4-WAY VALVE		1			
18	R01 E75 202	THERMISTOR (LOW PRESSURE SATURATED, OUTDOOR)		1		TH6,7	
19	T7W E05 208	HIGH PRESSURE SWITCH		1		63H	
20	T7W E29 408	HEAT EXCHANGER		1			
21	T7W E02 259	CONTACTOR		1		52C	
22	T7W 850 716	TERMINAL BLOCK	3P (L1,L2,GR)	1		TB1	
23	T7W E14 346	NOISE FILTER CIRCUIT BOARD		1		N.F.	
24	R01 H76 310	MULTI CONTROLLER CIRCUIT BOARD		1		MULTI.B.	
25	T7W E17 716	TERMINAL BLOCK	3P (M1, M2, S)	2		TB3, TB7	
26	R01 E01 311	TRANSMISSION POWER BOARD		1		M-P.B.	
27	T7W E01 234	RESISTOR		1		RS	
28	T7W E09 259	REACTOR		1		DCL	
29	T7W E26 313	POWER CIRCUIT BOARD		1		P.B.	
30	T7W E01 233	ACT MODULE		1		ACTM	
31	T7W E09 254	MAIN SMOOTHING CAPACITOR		1		CB	
32	R01 E66 202	THERMISTOR (OUTDOOR PIPE)		1		TH3	
33	R01 E00 201	THERMISTOR (DISCHARGE)		1		TH4	
34	R01 E65 202	THERMISTOR (Heat sink)		1		TH8	

14-1. FUNCTIONAL PARTS

- PUMY-P36NHMU(-BS)
- PUMY-P36NHMUR1(-BS)
- PUMY-P36NHMUR4(-BS)
- PUMY-P48NHMU<sub>2</sub>(-BS)
- PUMY-P48NHMUR3(-BS)
- PUMY-P48NHMUR4(-BS)

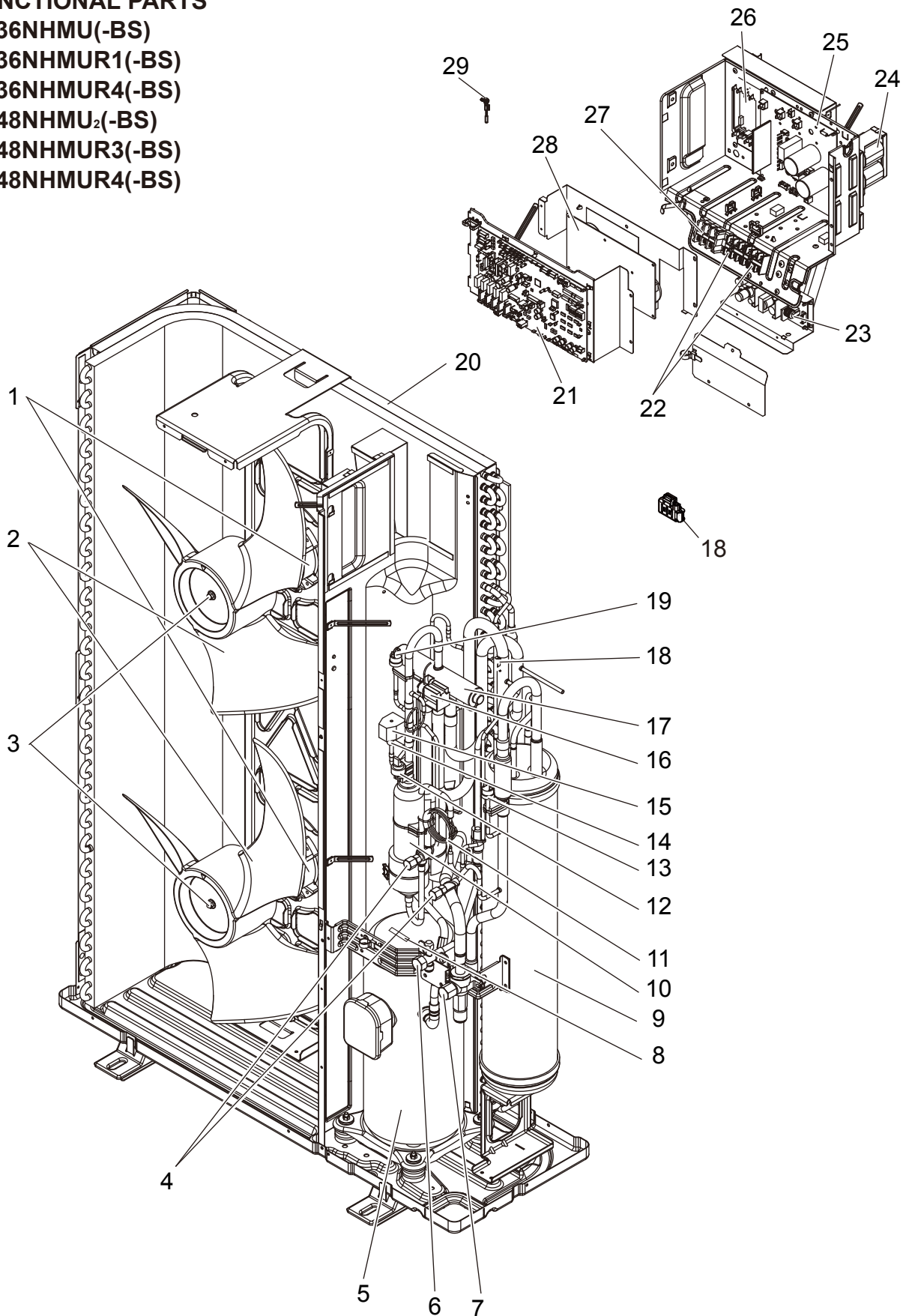

# RoHS PARTS LIST

Parts numbers that are circled are not shown in the figure.

No.	RoHS	Parts No.	Part Name	Specification	Q'ty/unit			Remarks (Drawing No.)	Wiring Diagram Symbol	Recom- mended Q'ty
					PUMY-P·(-BS)					
					36NHMU 48NHMU <sub>2</sub>	36NHMUR1 48NHMUR3	36NHMUR4 48NHMUR4			
1	G	T7W E27 763	FAN MOTOR		2	2			MF1,2	
	G	R01 E57 221	FAN MOTOR				2		MF1,2	
2	G	R01 E12 115	PROPELLER FAN		2	2	2			
3	G	R01 E09 097	NUT		2	2	2			
4	G	T7W E07 413	CHARGE PLUG		2					
	G	T7W E12 413	CHARGE PLUG			2	2			
5	G	T97 415 755	COMPRESSOR	ANB33FDHMT Including RUBBER MOUNT	1				MC	
	G	T97 415 779	COMPRESSOR	ANB33FDSMT Including RUBBER MOUNT		1	1		MC	
6	G	T7W E04 410	STOP VALVE	3/8	1	1	1			
7	G	T7W E06 411	BALL VALVE	5/8	1	1	1			
8	G	R01 E28 201	THERMISTOR (COMPRESSOR)			1	1		TH4	
9	G	R01 E44 440	ACCUMULATOR		1	1	1			
10	G	T7W E02 490	OIL SEPARATOR		1	1	1			
11	G	R01 E26 425	CAPILLARY TUBE	$\phi 2.5 \times \phi 0.8 \times 1000 \text{mm}$ [ $\phi(3/32) \times \phi(1/32) \times L(39-1/2)$ ]inch	1	1	1			
12	G	R01 E07 208	H.P SENSOR		1	1	1		63HS	
13	G	R01 E00 209	LOW PRESSURE SWITCH		1	1	1		63L	
14	G	T7W E03 428	BYPASS VALVE		1	1	1			
15	G	T7W E17 242	SOLENOID COIL <BYPASS VALVE>		1	1	1		SV1	
16	G	T7W E18 242	SOLENOID COIL <4-WAY VALVE>		1	1	1		21S4	
17	G	T7W E05 403	4-WAY VALVE		1	1	1			
18	G	R01 H01 202	THERMISTOR (LOW PRESSURE SATURATED, OUTDOOR)		1	1	1		TH6, 7	
19	G	T7W E07 208	HIGH PRESSURE SWITCH		1	1	1		63H	
20	G	T7W E41 408	HEAT EXCHANGER		1	1	1			
21	G	R01 V03 310	CONTROLLER CIRCUIT BOARD		1				C.B.	
	G	R01 V14 310	CONTROLLER CIRCUIT BOARD			1			C.B.	
	G	T7W F24 315	CONTROLLER CIRCUIT BOARD				1		C.B.	
22	G	R01 E27 246	TERMINAL BLOCK	3P (M1,M2,S)	2	2	2		TB3,TB7	
23	G	R01 E02 311	M-POWER BOARD		1				M-NET.P.B.	
	G	R01 E04 311	M-POWER BOARD			1	1		M-NET.P.B.	
24	G	R01 E20 259	REACTOR		1				DCL	
	G	T7W E17 259	REACTOR			1			DCL	
	G	R01 E44 259	REACTOR				1		DCL	
25	G	R01 E64 313	POWER CIRCUIT BOARD		1				P.B.	
	G	R01 E65 313	POWER CIRCUIT BOARD			1	1		P.B.	
26	G	R01 E07 233	ACT MODULE		1	1	1		ACTM	
27	G	T7W E45 716	TERMINAL BLOCK	3P (L1,L2,GR)	1	1	1		TB1	
28	G	R01 E18 346	NOISE FILTER CIRCUIT BOARD	6P	1	1	1		N.F.	
29	G	R01 E99 202	THERMISTOR (Heat sink)		1	1	1		TH8	
(30)	G	R01 E22 255	MAIN SMOOTHING CAPACITOR		1	1	1		CE	
(31)	G	R01 H00 202	THERMISTOR (OUTDOOR PIPE)		1	1	1		TH3	
(32)	G	R01 E12 201	THERMISTOR (DISCHARGE)		1				TH4	
(32)	G	R01 E06 239	FUSE	250 V 6.3 A	2	2	2		F1,2	

# RoHS PARTS LIST

## 14-2. STRUCTURAL PARTS

PUMY-P36NHMU(-BS)  
 PUMY-P36NHMUR1(-BS)  
 PUMY-P36NHMUR4(-BS)  
 PUMY-P48NHMU<sub>2</sub>(-BS)  
 PUMY-P48NHMUR3(-BS)  
 PUMY-P48NHMUR4(-BS)

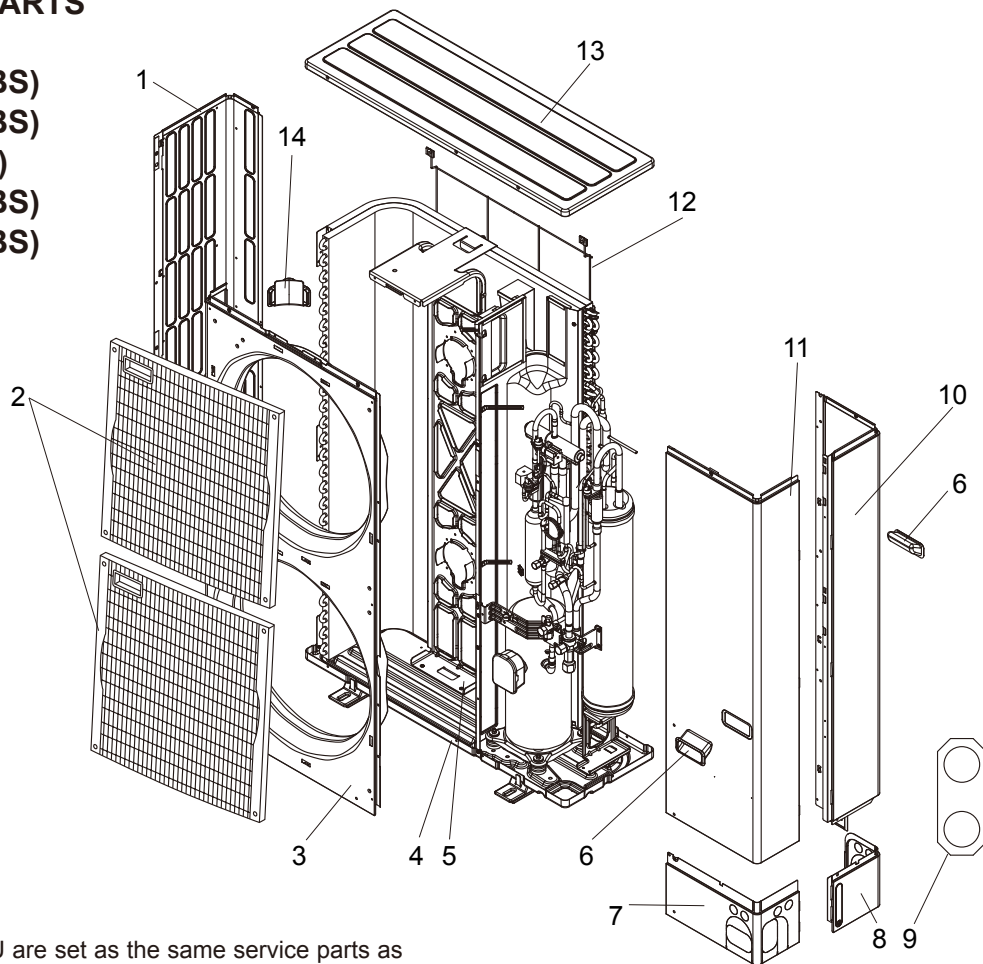

Note:

Parts of PUMY-P36/48NHMU are set as the same service parts as PUMY-P36/48NHMU-BS.

No.	RoHS	Parts No.	Part Name	Speci- fication	Q'ty/unit			Remarks (Drawing No.)	Wiring Diagram Symbol	Recom- mended Q'ty
					PUMY-P·(-BS)					
					36NHMU 36NHMUR1	48NHMU <sub>2</sub> 48NHMUR3	36NHMUR4 48NHMUR4			
1	G	R01 E33 662	SIDE PANEL (L)		1	1	1			
2	G	T7W E03 691	FAN GRILLE		2	2	2			
3	G	T7W E06 667	FRONT PANEL		1	1	1			
4	G	R01 E26 686	BASE ASSY		1	1	1			
5	G	R01 E19 130	MOTOR SUPPORT		1	1	1			
6	G	R01 E01 655	HANDLE		2	2	2			
7	G	R01 E14 658	COVER PANEL (FRONT)		1	1	1			
8	G	R01 E24 658	COVER PANEL (REAR)		1	1	1			
9	G	T7W E01 617	CONDUIT PLATE		1	1	1			
10	G	R01 E57 661	SIDE PANEL (R)		1	1	1			
11	G	T7W E06 668	SERVICE PANEL		1	1	1			
12	G	R01 E07 698	REAR GUARD		1	1	1			
13	G	R01 E29 641	TOP PANEL		1	1	1			
14	G	R01 E02 655	HANDLE		1	1	1			

**DRAIN SOCKET**

Parts No.	PAC-SG61DS-E
-----------	--------------

**AIR OUTLET GUIDE**

Parts No.	PAC-SG59SG-E
-----------	--------------

Note: Need 2 pieces.

**AIR GUIDE**

Parts No.	PAC-SH63AG-E
-----------	--------------

Note: Need 2 pieces.

**DRAIN PAN**

Parts No.	PAC-SG64DP-E
-----------	--------------

**BRANCH PIPE (Joint)**

Parts No.	NUMBER OF BRANCHING POINTS
CMY-Y62-G-E	2
CMY-Y64-G-E	4
CMY-Y68-G-E	8

# CITY MULTI™

## MITSUBISHI ELECTRIC CORPORATION

HEAD OFFICE: TOKYO BLDG., 2-7-3, MARUNOUCHI, CHIYODA-KU, TOKYO100-8310, JAPAN

©Copyright 2006 MITSUBISHI ELECTRIC CORPORATION  
Distributed in Jun. 2015 No. OC366 REVISED EDITION-K  
Distributed in Mar. 2014 No. OC366 REVISED EDITION-J  
Distributed in Sep. 2012 No. OC366 REVISED EDITION-H  
Distributed in Sep. 2011 No. OC366 REVISED EDITION-G  
Distributed in Dec. 2010 No. OC366 REVISED EDITION-F  
Distributed in Sep. 2010 No. OC366 REVISED EDITION-E PDF 5  
Distributed in Nov. 2009 No. OC366 REVISED EDITION-D PDF 7  
Distributed in Jul. 2008 No. OC366 REVISED EDITION-C PDF 7  
Distributed in Dec. 2007 No. OC366 REVISED EDITION-B PDF 9  
Distributed in Apr. 2006 No. OC366 REVISED EDITION-A PDF 10  
Distributed in Jan. 2006 No. OC366 PDF 10  
Made in Japan

New publication, effective Jun. 2015  
Specifications are subject to change without notice.