

# SERVICE PARTS LIST FOR MITSUBISHI ELECTRIC PACKAGED AIR-CONDITIONERS

**Series : PUHY-HP·THMU-A(-BS)**

**For use with the R410A**

**REVISED**

**Nov. 2007**

**BWE0722A**

## INDEX

**PUHY-HP72THMU-A**

**PUHY-HP72THMU-A-BS**

**PUHY-HP96THMU-A**

**PUHY-HP96THMU-A-BS**

## The Package name list

**PUHY-HP144TSHMU-A(-BS)** [PUHY-HP72THMU-A(-BS) + PUHY-HP72THMU-A(-BS)]

**PUHY-HP192TSHMU-A(-BS)** [PUHY-HP96THMU-A(-BS) + PUHY-HP96THMU-A(-BS)]



PUHY-HP72THMU-A (-BS)  
PUHY-HP96THMU-A (-BS)

EXTERNAL PARTS & BLOWER PARTS

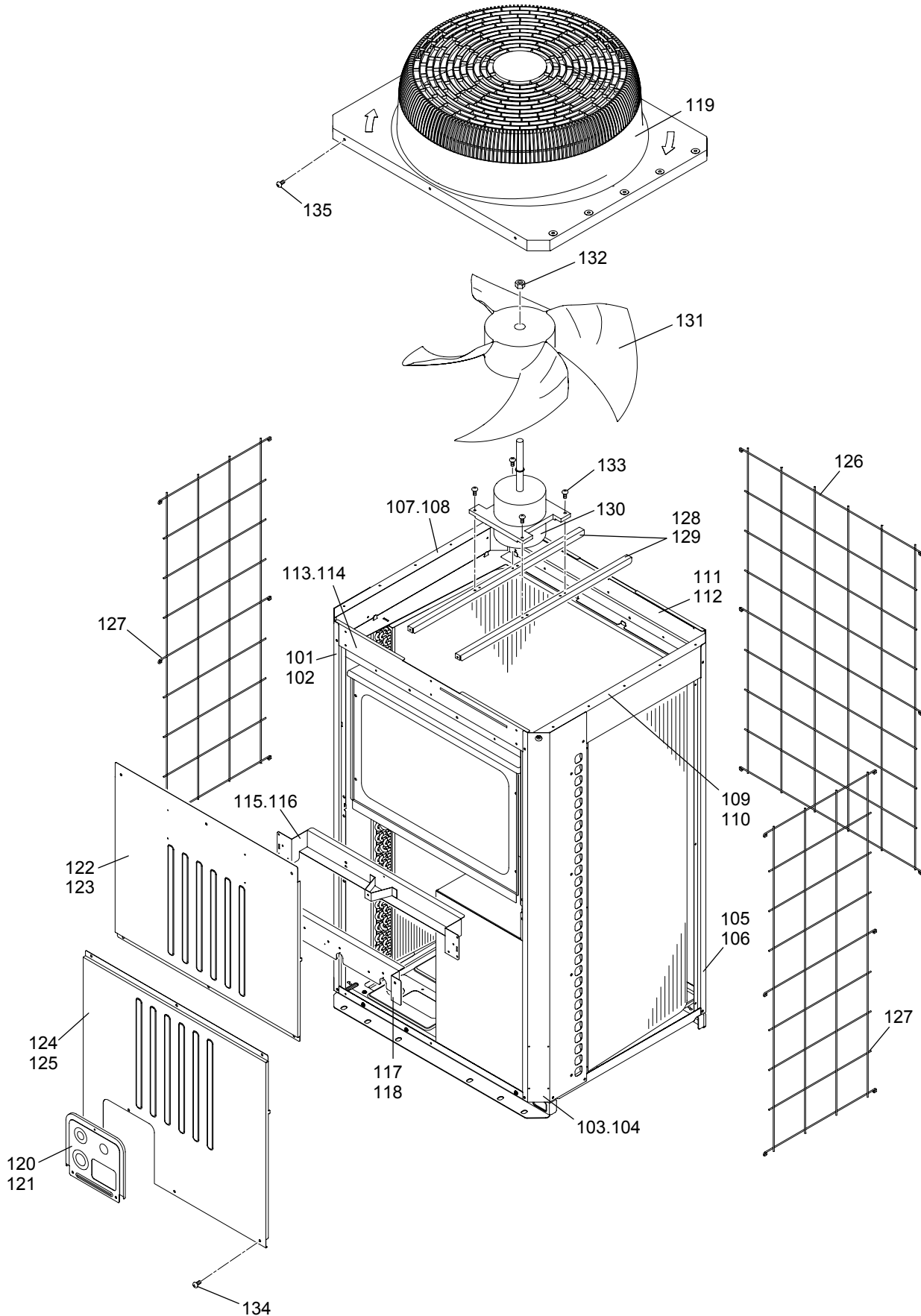



PUHY-HP72THMU-A (-BS)  
PUHY-HP96THMU-A (-BS)

FUNCTIONAL PARTS

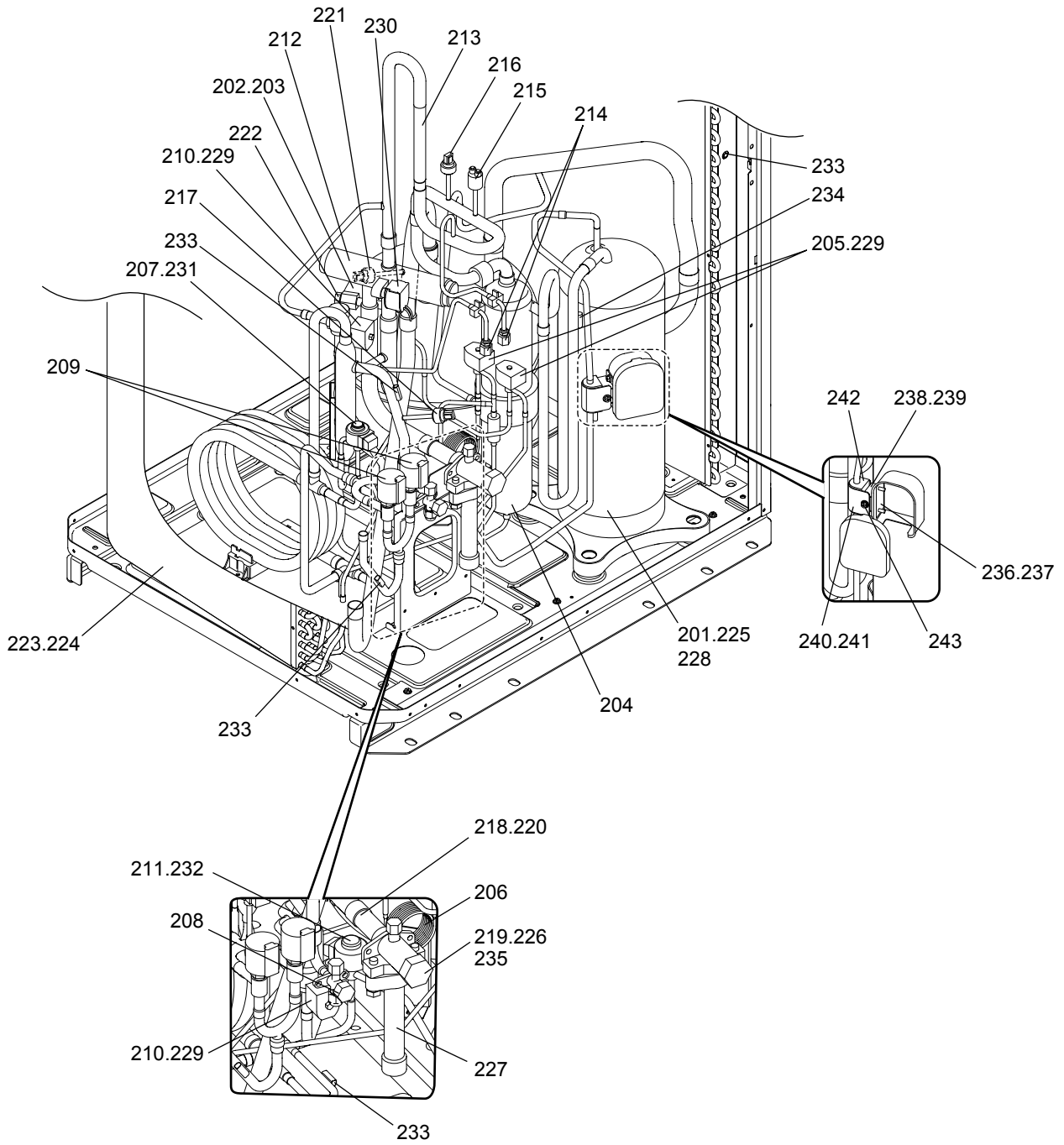

PUHY-HP72THMU-A (-BS)  
 PUHY-HP96THMU-A (-BS)

FUNCTIONAL PARTS

No.	Part No.	G : RoHS Apply Only W : RoHS Apply by Running Change		Spec.	PUHY-HP72THMU-A	PUHY-HP72THMU-A-BS	PUHY-HP96THMU-A	PUHY-HP96THMU-A-BS	Dwg. No.	Price	Revision History
			Part Name								
201	R69 021 478	W	Scroll compressor	HNK78FA(S)	1	1	1	1	EP10113B01		A
202	R61 022 484		Accumulator assy		1	1			KB54B626G01		
203	R61 023 484		Accumulator assy	BS		1	1		KB54B626G02		
204	R61 005 487	G	Oil separator assy		1	1	1	1	KB00G667G01		
205	R61 034 232	G	Solenoid valve	VPV U	2	2	2	2	P631294X01		
206	R61 4H6 425	W	Capillary tube assy		1	1	1	1	KB49D217G01		
207	R63 S84 401	G	Expansion valve	CAM-B50	1	1	1	1	P632418X01		
208	R61 4H6 538	W	Service valve	3/8	1	1	1	1	P636319X01		
209	R63 4H7 401	G	Linearexpansion valve	EBM-A XA <LEV2a,LEV2b>	2	2	2	2	P632445X01		
210	R13 851 921	W	Solenoid valve	VPV	2	2	2	2	P631822X01		
211	R61 7F3 402	W	Expansion valve	HAM-BDMD	1	1	1	1	P632402X02		
212	R63 Y05 154	G	Four way valve	STF-07	1	1	1	1	P633119X01		
213	R63 R43 418	G	Check valve	BCV-1005	1	1	1	1	P639165X01		
214	R63 R34 413	G	Check joint L	R410A	2	2	2	2	P666001X01		
215	R63 Y11 208	G	Pressure switch	ACB1UB28W <63H1>	1	1	1	1	P426320X01		
216	R61 006 288	G	Pressure sensor	HP <63HS1>	1	1	1	1	KB00H904G03		
217	R61 008 288		Pressure sensor	HP <63HS2>	1	1	1	1	KB00F899G05		
218	R63 4H6 454	G	Strainer	19.05D	1	1			P641128X01		
219	R61 004 410	W	Valve	VSAMH8SFCM			1	1	P636336X01		
220	R63 5H4 454	G	Strainer	25.4D			1	1	P641125X01		
221	R61 007 288	G	Pressure sensor	LP <63LS>	1	1	1	1	KB00H904G04		
222	R11 707 890	W	Fusible plug		1	1	1	1	P649019X01		
223	R61 145 480	G	Heat exchanger assy	THMU-A	1		1		KB01C181G10		
224	R61 146 480	G	Heat exchanger assy	THMU-A BS		1		1	KB01C181G11		
225	R61 Y10 236	W	Crank case heater	<CH11>	1	1	1	1	P497020X01		
226	R61 5H4 635	W	Gasket		1	1	1	1	P646012X01		
227	R61 030 494		Pipe assy	ID22.2			1	1	KB00L280G02		
228	R63 852 860	G	Rubber mount		4	4	4	4	W897574H01		
229	R61 011 243	G	Solenoid coil	VPV UL <SV1a,SV2,SV6,SV9>	4	4	4	4	P472047X01		
230	R61 Y21 243	W	Solenoid coil	STF-01 <21S4a>	1	1	1	1	P472028X01		
231	R63 4H6 402	G	Solenoid coil	CAM <LEV1>	1	1	1	1	P472035X02		
232	R61 4H8 402	W	Solenoid coil	HAM <LEV4>	1	1	1	1	P472034X02		
233	R63 670 202	G	Thermistor	MDW103H <TH2,TH3,TH6,TH7>	4	4	4	4	P425496X01		
234	R63 911 202	G	Thermistor	<TH4>	1	1	1	1	P425416X02		
235	R61 003 410	W	Valve	VSAMH6SF-CM	1	1			P636335X01		
236	R61 001 132		Attachment plate		1		1		KB02K008H01		
237	R61 002 132		Attachment plate	BS		1		1	KB02K008H02		
238	R61 001 609		Attachment saddle		1		1		KB02H227H01		
239	R61 002 609		Attachment saddle	BS		1		1	KB02H227H02		
240	R61 001 456		Saddle		1		1		KB02H226H01		
241	R61 002 456		Saddle	BS		1		1	KB02H226H02		
242	R11 935 905	W	Packing		2	2	2	2	W483653G05		
243	R61 010 087	G	Upset screw	M5×12	3	3	3	3	S516322H01		

PUHY-HP72THMU-A (-BS)  
PUHY-HP96THMU-A (-BS)

CONTROL BOX PARTS

