

TECHNICAL & SERVICE MANUAL

CITY MULTI Series Ceiling Cassettes R410A

Indoor unit [Model Name]	[Service Ref.]
PLFY-P08NEMU-E	PLFY-P08NEMU-E
PLFY-P12NEMU-E	PLFY-P12NEMU-E
PLFY-P15NEMU-E	PLFY-P15NEMU-E
PLFY-P18NEMU-E	PLFY-P18NEMU-E
PLFY-P24NEMU-E	PLFY-P24NEMU-E
PLFY-P30NEMU-E	PLFY-P30NEMU-E
PLFY-P36NEMU-E	PLFY-P36NEMU-E
PLFY-P48NEMU-E	PLFY-P48NEMU-E

Revision:
• DISASSEMBLY PROCEDURE
has been modified in
REVISED EDITION-D.
• Some descriptions have been
modified.

OCH611 REVISED EDITION-C
is void.

CONTENTS

1. SAFETY PRECAUTION.....	2
2. PARTS NAMES AND FUNCTIONS.....	4
3. SPECIFICATIONS.....	11
4. 4-WAY AIRFLOW SYSTEM.....	16
5. OUTLINES AND DIMENSIONS.....	19
6. WIRING DIAGRAM.....	20
7. REFRIGERANT SYSTEM DIAGRAM.....	21
8. MICROPROCESSOR CONTROL.....	22
9. TROUBLESHOOTING.....	29
10. DISASSEMBLY PROCEDURE.....	37

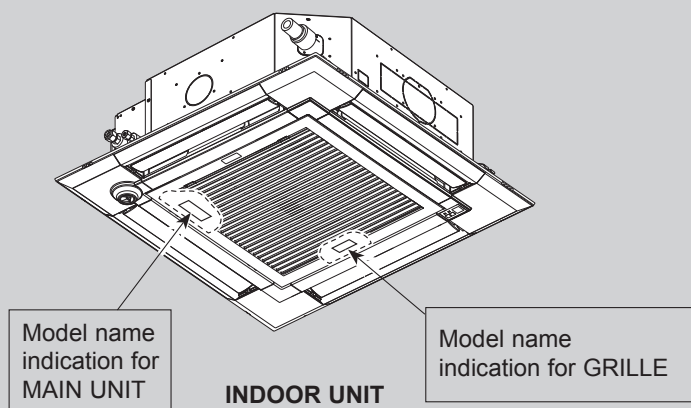

PARTS CATALOG (OCB611)

CITY MULTI

CAUTIONS RELATED TO NEW REFRIGERANT

Cautions for units utilizing refrigerant R410A

Do not use the existing refrigerant piping.

The old refrigerant and lubricant in the existing piping contains a large amount of chlorine which may cause the lubricant deterioration of the new unit.

Use “low residual oil piping”

If there is a large amount of residual oil (hydraulic oil, etc.) inside the piping and joints, deterioration of the lubricant will result.

Store the piping indoors, and keep both ends of the piping sealed until just before brazing. (Leave elbow joints, etc. in their packaging.)

If dirt, dust or moisture enters into refrigerant cycle, that can cause deterioration of refrigerant oil or malfunction of compressor.

The refrigerant oil applied to flare and flange connections must be ester oil, ether oil or alkylbenzene oil in a small amount.

If large amount of mineral oil enters, that can cause deterioration of refrigerant oil, etc.

Charge refrigerant from liquid phase of gas cylinder.

If the refrigerant is charged from gas phase, composition change may occur in refrigerant and the efficiency will be lowered.

Do not use refrigerant other than R410A.

If other refrigerant (R22, etc.) is used, chlorine in refrigerant can cause deterioration of refrigerant oil, etc.

Use a vacuum pump with a reverse flow check valve.

Vacuum pump oil may flow back into refrigerant cycle and that can cause deterioration of refrigerant oil, etc.

Use the following tools specifically designed for use with R410A refrigerant.

The following tools are necessary to use R410A refrigerant.

Tools for R410A	
Gauge manifold	Flare tool
Charge hose	Size adjustment gauge
Gas leak detector	Vacuum pump adaptor
Torque wrench	Electronic refrigerant charging scale

Handle tools with care.

If dirt, dust or moisture enters into refrigerant cycle, that can cause deterioration of refrigerant oil or malfunction of compressor.

Do not use a charging cylinder.

If a charging cylinder is used, the composition of refrigerant will change and the efficiency will be lowered.

Use the specified refrigerant only.**Never use any refrigerant other than that specified.**

Doing so may cause a burst, an explosion, or fire when the unit is being used, serviced, or disposed of.

Correct refrigerant is specified in the manuals and on the spec labels provided with our products.

We will not be held responsible for mechanical failure, system malfunction, unit breakdown or accidents caused by failure to follow the instructions.

Ventilate the room if refrigerant leaks during operation. If refrigerant comes into contact with a flame, poisonous gases will be released.

[1] Cautions for service

- (1) Perform service after recovering the refrigerant left in unit completely.
- (2) Do not release refrigerant in the air.
- (3) After completing service, charge the cycle with specified amount of refrigerant.
- (4) When performing service, install a filter drier simultaneously.
Be sure to use a filter drier for new refrigerant.

[2] Additional refrigerant charge

When charging directly from cylinder

- Check that cylinder for R410A on the market is a syphon type.
- Charging should be performed with the cylinder of syphon standing vertically. (Refrigerant is charged from liquid phase.)

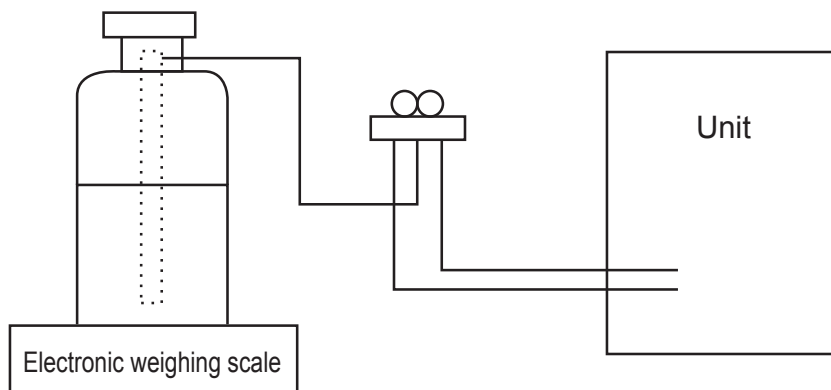

[3] Service tools

Use the below service tools as exclusive tools for R410A refrigerant.

No.	Tool name	Specifications
①	Gauge manifold	<ul style="list-style-type: none"> · Only for R410A · Use the existing fitting specifications. (UNF1/2) · Use high-tension side pressure of 768.7 PSIG [5.3M Pa.G] or over.
②	Charge hose	<ul style="list-style-type: none"> · Only for R410A · Use pressure performance of 738.2 PSIG [5.09M Pa.G] or over.
③	Electronic weighing scale	—
④	Gas leak detector	· Use the detector for R134a, R407C or R410A.
⑤	Adaptor for reverse flow check	· Attach on vacuum pump.
⑥	Refrigerant charge base	—
⑦	Refrigerant cylinder	<ul style="list-style-type: none"> · Only for R410A · Top of cylinder (Pink) · Cylinder with syphon
⑧	Refrigerant recovery equipment	—

2

PARTS NAMES AND FUNCTIONS

2-1. Indoor Unit

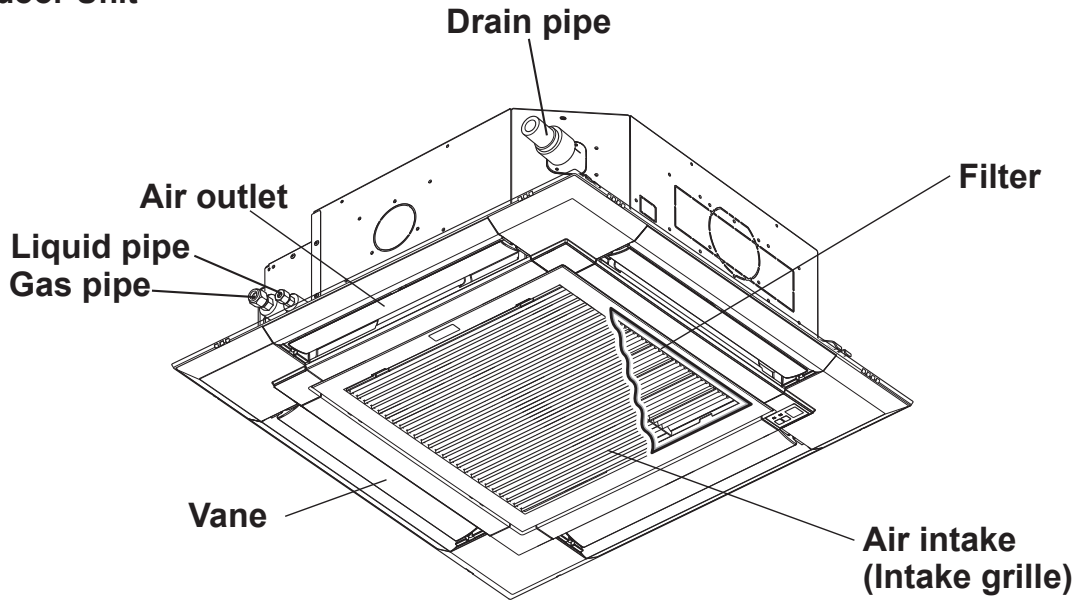

2-2. Wired Remote Controller <PAR-33MAA> <PAC-YT53CRAU>

Wired remote controller function

The functions which can be used are restricted according to each model.

○ : Supported × : Unsupported

	Function	PAR-33MAA		PAC-YT53CRAU
		Slim	City multi	
Body	Product size H × W × D (mm)	120 × 120 × 19		120 × 70 × 14.5
	LCD	Full Dot LCD		Partial Dot LCD
	Backlight	○		○
Energy-saving	Energy-saving operation schedule	○	×	×
	Automatic return to the preset temperature	○		×
Restriction	Setting the temperature range restriction	○		○
Function*	Operation lock function	○		○
	Weekly timer	○		×
	ON/OFF timer	○		×
	High Power	○	×	×
	Manual vane angle	○		×

*Some functions may not be available depending on model types.

2-2-1. Wired Remote Controller <Option>

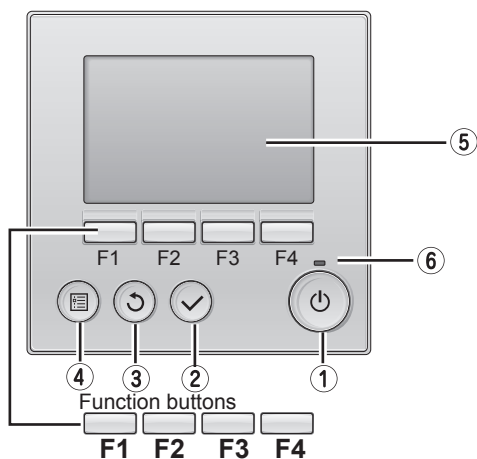

① ON/OFF button

Press to turn ON/OFF the indoor unit.

② SELECT button

Press to save the setting.

③ RETURN button

Press to return to the previous screen.

④ MENU button

Press to bring up the Main menu.

⑤ Backlit LCD

Operation settings will appear.
When the backlight is off, pressing any button turns the backlight on and it will stay lit for a certain period of time depending on the screen.

When the backlight is off, pressing any button turns the backlight on and does not perform its function. (except for the  (ON/OFF) button)

The functions of the function buttons change depending on the screen. Refer to the button function guide that appears at the bottom of the LCD for the functions they serve on a given screen.

When the system is centrally controlled, the button function guide that corresponds to the locked button will not appear.

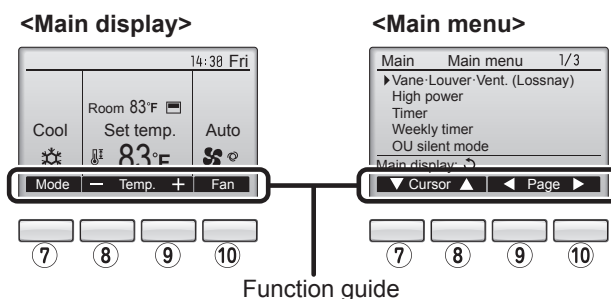

⑥ ON/OFF lamp

This lamp lights up in green while the unit is in operation. It blinks while the remote controller is starting up or when there is an error.

⑦ Function button **F1**

Main display : Press to change the operation mode.
Main menu : Press to move the cursor down.

⑧ Function button **F2**

Main display : Press to decrease temperature.
Main menu : Press to move the cursor up.

⑨ Function button **F3**

Main display : Press to increase temperature.
Main menu : Press to go to the previous page.

⑩ Function button **F4**

Main display : Press to change the fan speed.
Main menu : Press to go to the next page.

The main display can be displayed in 2 different modes: "Full" and "Basic".

The initial setting is "Full". To switch to the "Basic" mode, change the setting on the Main display setting.

<Full mode>

All icons are displayed for explanation.

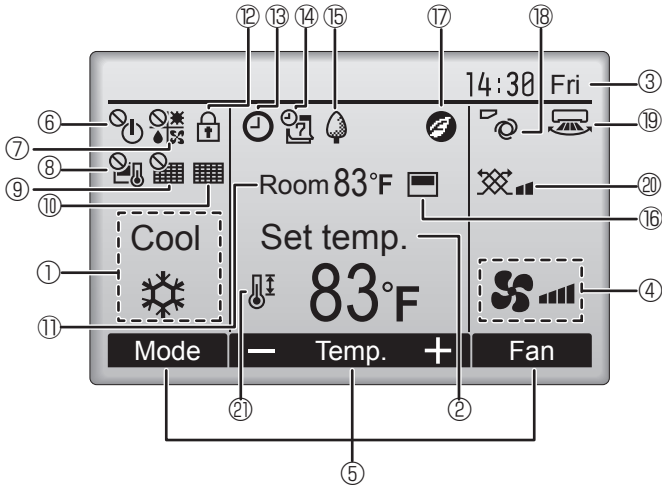

<Basic mode>

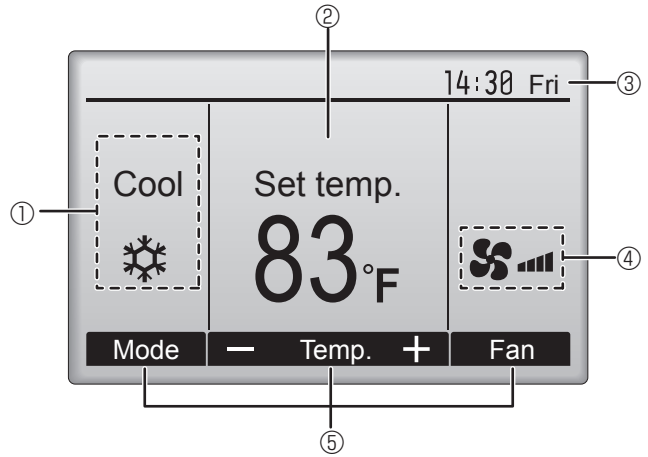

① Operation mode

Indoor unit operation mode appears here.

② Preset temperature

Preset temperature appears here.

③ Clock (See the Installation Manual.)

Current time appears here.

④ Fan speed

Fan speed setting appears here.

⑤ Button function guide

Functions of the corresponding buttons appear here.



Appears when the ON/OFF operation is centrally controlled.



Appears when the operation mode is centrally controlled.



Appears when the preset temperature is centrally controlled.



Appears when the filter reset function is centrally controlled.



Indicates when filter needs maintenance.

⑪ Room temperature (See the Installation Manual.)

Current room temperature appears here.



Appears when the buttons are locked.



Appears when the On/Off timer or Night setback function is enabled.



Appears when the Weekly timer is enabled.



Appears while the units are operated in the energy-saving mode.



Appears when the built-in thermistor on the remote controller is activated to monitor the room temperature.

appears when the thermistor on the indoor unit is activated to monitor the room temperature.



Appears when the units are operated in the energy-save mode with 3D i-see Sensor. (This function is not available on this unit.)



Indicates the vane setting.



Indicates the louver setting. (This function is not available on this unit.)



Indicates the ventilation setting.



Appears when the preset temperature range is restricted.

Most settings (except ON/OFF, mode, fan speed, temperature) can be made from the Menu screen.

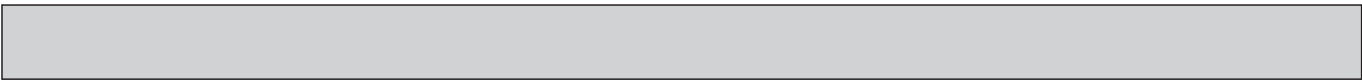

Main menu

Press the **MENU** button.
Move the cursor to the desired item with the **F1** and **F2** buttons, and press the **SELECT** button.

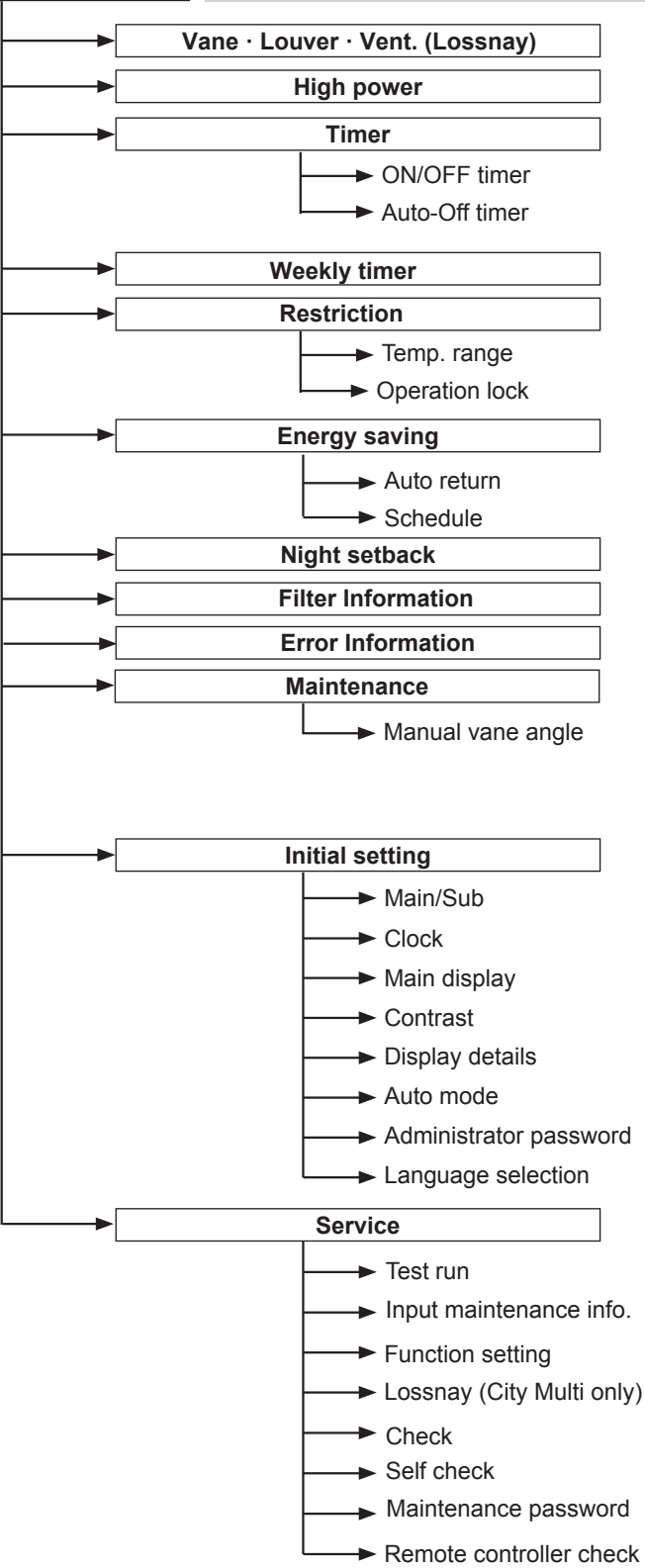

Not all functions are available on all models of indoor units.

Main menu list

Setting and display items		Setting details
Vane · Louver · Vent. (Lossnay)		<p>Use to set the vane angle.</p> <ul style="list-style-type: none"> • Select a desired vane setting from 5 different settings. <p>Use to turn ON/OFF the louver.</p> <ul style="list-style-type: none"> • Select a desired setting from "ON" and "OFF." <p>Use to set the amount of ventilation.</p> <ul style="list-style-type: none"> • Select a desired setting from "Off," "Low," and "High."
High power		<p>Use to reach the comfortable room temperature quickly.</p> <ul style="list-style-type: none"> • Units can be operated in the High-power mode for up to 30 minutes.
Timer	ON/OFF timer*	<p>Use to set the operation ON/OFF times.</p> <ul style="list-style-type: none"> • Time can be set in 5-minute increments.
	Auto-Off timer	<p>Use to set the Auto-Off time.</p> <ul style="list-style-type: none"> • Time can be set to a value from 30 to 240 in 10-minute increments.
Weekly timer*		<p>Use to set the weekly operation ON/OFF times.</p> <ul style="list-style-type: none"> • Up to 8 operation patterns can be set for each day. (Not valid when the ON/OFF timer is enabled.)
Restriction	Temp. range	<p>Use to restrict the preset temperature range.</p> <ul style="list-style-type: none"> • Different temperature ranges can be set for different operation modes.
	Operation lock	<p>Use to lock selected functions.</p> <ul style="list-style-type: none"> • The locked functions cannot be operated.
Energy saving	Auto return	<p>Use to get the units to operate at the preset temperature after performing energy-save operation for a specified time period.</p> <ul style="list-style-type: none"> • Time can be set to a value from 30 and 120 in 10-minute increments. (This function will not be valid when the preset temperature ranges are restricted.)
	Schedule*	<p>Set the start/stop times to operate the units in the energy-save mode for each day of the week, and set the energy-saving rate.</p> <ul style="list-style-type: none"> • Up to 4 energy-save operation patterns can be set for each day. • Time can be set in 5-minute increments. • Energy-saving rate can be set to a value from 0% or 50 to 90% in 10% increments.
Night setback*		<p>Use to make Night setback settings.</p> <ul style="list-style-type: none"> • Select "Yes" to enable the setting, and "No" to disable the setting. The temperature range and the start/stop times can be set.
Filter information		<p>Use to check the filter status.</p> <ul style="list-style-type: none"> • The filter sign can be reset.
Error information		<p>Use to check error information when an error occurs.</p> <ul style="list-style-type: none"> • Check code, error source, refrigerant address, unit model, manufacturing number, contact information (dealer's phone number) can be displayed. (The unit model, manufacturing number, and contact information need to be registered in advance to be displayed.)
Maintenance	Manual vane angle	<p>Use to set the vane angle for each vane to a fixed position.</p>
Initial setting	Clock	<p>Use to set the current time.</p>
	Main display	<p>Use to switch between "Full" and "Basic" modes for the Main display.</p> <ul style="list-style-type: none"> • The initial setting is "Full."
	Contrast	<p>Use to adjust screen contrast.</p>
	Language selection	<p>Use to select the desired language.</p>

*Clock setting is required.

Continue to the next page

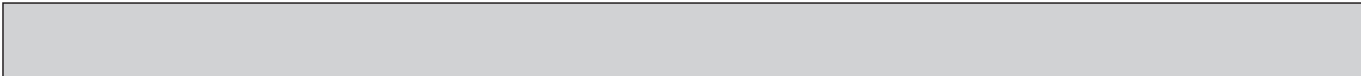

Setting and display items		Setting details
	Input maintenance	Select "Input maintenance Info." from the Service menu to bring up the Maintenance information screen. The following settings can be made from the Maintenance Information screen. • Model name input • Serial No. input • Dealer information input
	LOSSNAY setting	This setting is required only when the operation of City Multi units is interlocked with LOSSNAY units.
	Check	Error history: Display the error history and execute delete error history.
	Self check	Error history of each unit can be checked via the remote controller.
	Maintenance password	Use to change the maintenance password.
	Remote controller check	When the remote controller does not work properly, use the remote controller checking function to troubleshoot the problem.

2-2-2. Wired Remote Controller <PAC-YT53CRAU>

Note:

The phrase "Wired remote controller" in this manual refers only to the **PAC-YT53CRAU**.

If you need any information for the other remote controller, please refer to either the installation manual or initial setting manual which are included in remote controller's box.

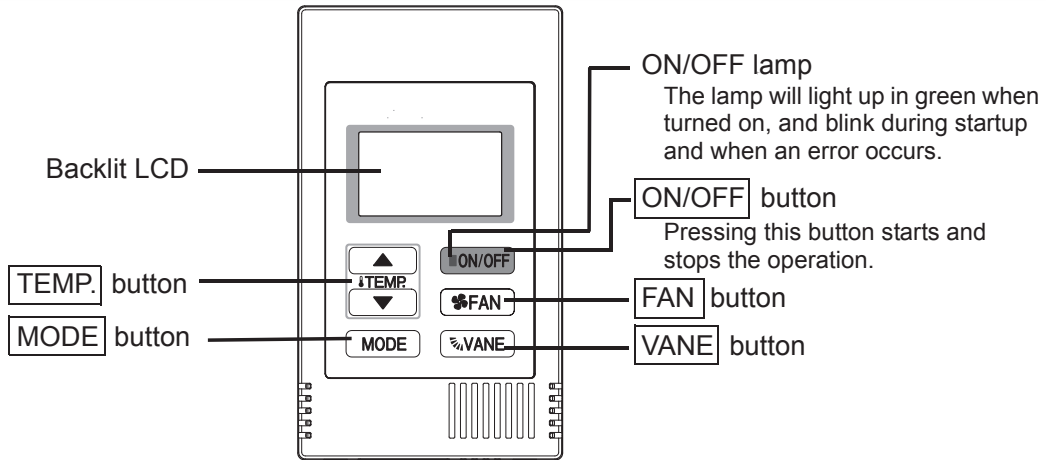

Note: To set the functions that are not available on this controller (**PAC-YT53CRAU**) such as Louver, use the centralized controller.

Display section

Note: All icons are displayed for explanation purpose

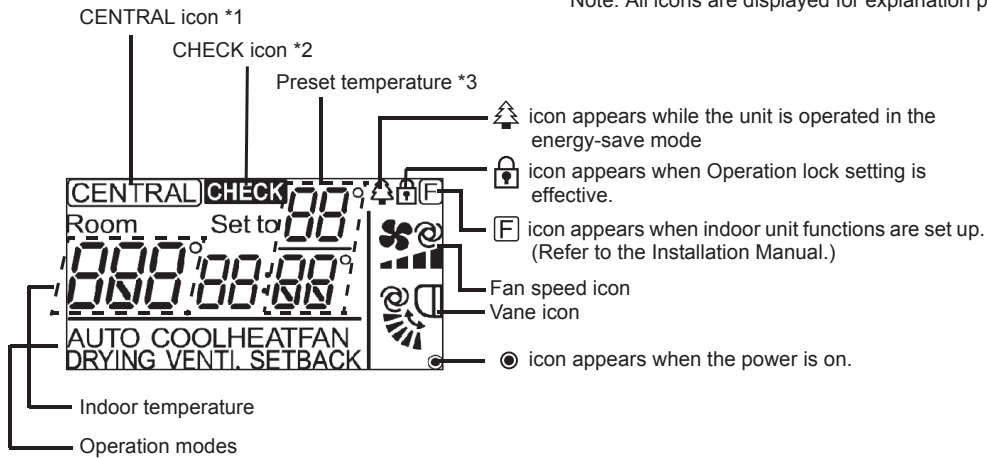

*1 **CENTRAL** icon

Appears when one of the following local operations is prohibited: ON/OFF; operation mode; preset temperature; fan speed; vane.

*2 **CHECK** icon

For City Multi, when an error occurs, power indicator will blink, and unit address (3 digits) and check code (4 digits) will blink.

Check the error status, stop the operation, and consult your dealer.

*3 Preset temperature

* Centigrade or Fahrenheit is selectable. Refer to the Installation Manual for details.

In COOL, DRYING, HEAT, or AUTO (single set point) modes

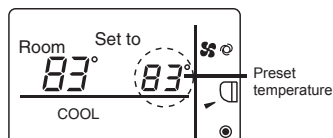

In AUTO (dual set point) or SETBACK modes

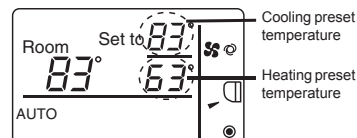

3

SPECIFICATIONS

3-1. SPECIFICATIONS

Service Ref.	PLFY-P08NEMU-E		PLFY-P12NEMU-E		PLFY-P15NEMU-E		PLFY-P18NEMU-E		
Power source	1-Phase 208–230 V, 60 HZ								
Cooling capacity (Nominal)	*1 BTU/h	8,000	12,000	15,000	18,000				
	*1 kW	2.4	3.5	4.4	5.3				
	Power input kW	0.02	0.02	0.02	0.02				
	Current input A	0.25	0.26	0.29	0.29				
Heating capacity (Nominal)	*2 BTU/h	9,000	13,500	17,000	20,000				
	*2 kW	2.7	4.0	5.0	5.9				
	Power input kW	0.02	0.02	0.02	0.02				
	Current input A	0.20	0.21	0.24	0.24				
External finish	Galvanized steel sheet								
External dimension H × W × D	in	10-3/16 × 33-3/32 × 33-3/32	10-3/16 × 33-3/32 × 33-3/32	10-3/16 × 33-3/32 × 33-3/32	10-3/16 × 33-3/32 × 33-3/32				
	mm	258 × 840 × 840	258 × 840 × 840	258 × 840 × 840	258 × 840 × 840				
Net weight	lb [kg]	42 [19]	42 [19]	42 [19]	42 [19]				
Grille	Model	PLP-40EAU		PLP-40EAU		PLP-40EAU		PLP-40EAU	
	External finish	MUNSELL (6.4Y 8.9/0.4)							
	Dimension H × W × D	in	1-9/16 × 37-3/8 × 37-3/8	1-9/16 × 37-3/8 × 37-3/8	1-9/16 × 37-3/8 × 37-3/8	1-9/16 × 37-3/8 × 37-3/8			
		mm	40 × 950 × 950	40 × 950 × 950	40 × 950 × 950	40 × 950 × 950			
	Net weight	lb [kg]	11 [5]	11 [5]	11 [5]	11 [5]			
Heat exchanger	Cross fin								
FAN	Type × Quantity	Turbo fan × 1		Turbo fan × 1		Turbo fan × 1		Turbo fan × 1	
	External static press.	in. WG	0.000 (208 V)	0.000 (208 V)	0.000 (208 V)	0.000 (208 V)			
		Pa	0	0	0	0			
		in. WG	0.000 (230 V)	0.000 (230 V)	0.000 (230 V)	0.000 (230 V)			
	Pa	0	0	0	0				
	Motor type	DC motor							
	Motor output	kW	0.050	0.050	0.050	0.050			
	Driving mechanism	Direct drive							
	Airflow rate (Low-Mid2-Mid1-High)	cfm	424-459-494-530	459-494-530-565	459-494-530-600	459-494-565-636			
		m ³ /min	12.0-13.0-14.0-15.0	13.0-14.0-15.0-16.0	13.0-14.0-15.0-17.0	13.0-14.0-16.0-18.0			
L/s		200-217-233-250	217-233-250-267	217-233-250-283	217-233-267-300				
Sound pressure level (Low-Mid2-Mid1-High) (measure in anechoic room)	dB <A>	27-29-30-31 (208–230 V)	27-29-30-31 (208–230 V)	28-29-30-31 (208–230 V)	28-30-31-32 (208–230 V)				
	dB <A>	—	—	—	—				
	dB <A>	—	—	—	—				
Insulation material	PS								
Air filter	PP honeycomb (long life filter, anti-bacterial type)								
Protection device	Fuse								
Refrigerant control device	LEV								
Connectable outdoor unit	R410, CITY MULTI								
Diameter of refrigerant pipe (O.D.)	Liquid	in [mm]	1/4 [6.35] Flare	1/4 [6.35] Flare	1/4 [6.35] Flare	1/4 [6.35] Flare			
	Gas	in [mm]	1/2 [12.7] Flare	1/2 [12.7] Flare	1/2 [12.7] Flare	1/2 [12.7] Flare			
Field drain pipe size	in [mm]		O.D 1-1/4 [32]	O.D 1-1/4 [32]	O.D 1-1/4 [32]	O.D 1-1/4 [32]			
Standard attachment	Document, accessory								
Optional parts	Air outlet shutter plate		PAC-SJ37SP-E	PAC-SJ37SP-E	PAC-SJ37SP-E	PAC-SJ37SP-E			
	High efficiency filter element		PAC-SH59KF-E	PAC-SH59KF-E	PAC-SH59KF-E	PAC-SH59KF-E			
	Multi-function casement		PAC-SJ41TM-E	PAC-SJ41TM-E	PAC-SJ41TM-E	PAC-SJ41TM-E			
Remarks	Installation		Details on foundation work, duct work, insulation work, electrical wiring, power source switch, and other items shall be referred to the Installation Manual.						
	*1 Nominal cooling conditions Indoor: 80°F D.B./67°F W.B [26.7°C D.B./19.4°C W.B] Outdoor: 95°F D.B. [35°C D.B.] Pipe length: 25 ft [7.6m] Level difference: 0 ft [0 m]		*2 Nominal heating conditions 70°F D.B. [21.1°C D.B.] 47°F D.B./43°F W.B [8.3°C D.B./6.1°C W.B] 25 ft [7.6m] 0 ft [0 m]					Unit converter kcal/h = kW × 860 BTU/h = kW × 3,412 cfm = m ³ /min × 35.31 lb = kg/0.4536	
Note: Due to continuing improvement, above specification may be subject to change without notice.								Above specification data is subject to rounding variation.	



Service Ref.		PLFY-P24NEMU-E	PLFY-P30NEMU-E	PLFY-P36NEMU-E	PLFY-P48NEMU-E	
Power source		1-Phase 208–230 V, 60 HZ				
Cooling capacity (Nominal)	*1 BTU/h	24,000	30,000	36,000	48,000	
	*1 kW	7.0	8.8	10.5	14.1	
	Power input kW	0.04	0.05	0.08	0.10	
	Current input A	0.41	0.56	0.90	0.99	
Heating capacity (Nominal)	*2 BTU/h	27,000	34,000	40,000	54,000	
	*2 kW	7.9	10.0	11.7	15.8	
	Power input kW	0.04	0.05	0.08	0.10	
	Current input A	0.36	0.51	0.85	0.94	
External finish		Galvanized steel sheet				
External dimension H × W × D	in	10-3/16 × 33-3/32 × 33-3/32	10-3/16 × 33-3/32 × 33-3/32	11-3/4 × 33-3/32 × 33-3/32	11-3/4 × 33-3/32 × 33-3/32	
	mm	258 × 840 × 840	258 × 840 × 840	298 × 840 × 840	298 × 840 × 840	
Net weight	lb [kg]	46 [21]	46 [21]	51 [23]	55 [25]	
Grille	Model	PLP-40EAU	PLP-40EAU	PLP-40EAU	PLP-40EAU	
	External finish	MUNSELL (6.4Y 8.9/0.4)				
	Dimension H × W × D	in	1-9/16 × 37-3/8 × 37-3/8	1-9/16 × 37-3/8 × 37-3/8	1-9/16 × 37-3/8 × 37-3/8	1-9/16 × 37-3/8 × 37-3/8
		mm	40 × 950 × 950	40 × 950 × 950	40 × 950 × 950	40 × 950 × 950
	Net weight	lb [kg]	11 [5]	11 [5]	11 [5]	11 [5]
Heat exchanger		Cross fin				
FAN	Type × Quantity	Turbo fan × 1	Turbo fan × 1	Turbo fan × 1	Turbo fan × 1	
	External static press.	in. WG	0.000 (208 V)	0.000 (208 V)	0.000 (208 V)	0.000 (208 V)
		Pa	0	0	0	0
		in. WG	0.000 (230 V)	0.000 (230 V)	0.000 (230 V)	0.000 (230 V)
	Pa	0	0	0	0	
	Motor type	DC motor				
	Motor output kW	0.050	0.050	0.120	0.120	
	Driving mechanism	Direct drive				
Airflow rate (Low-Mid2-Mid1-High)	cfm	494-565-671-777	494-600-742-883	706-883-1,060-1,201	742-918-1,060-1,236	
	m ³ /min	14.0-16.0-19.0-22.0	14.0-17.0-21.0-25.0	20.0-25.0-30.0-34.0	21.0-26.0-30.0-35.0	
	L/s	233-267-317-367	233-283-350-417	333-417-500-567	350-433-500-583	
Sound pressure level (Low-Mid2-Mid1-High) (measure in anechoic room)	dB <A>	28-31-34-37 (208–230 V)	28-32-35-38 (208–230 V)	35-38-41-44 (208–230 V)	36-39-42-45 (208–230 V)	
	dB <A>	—	—	—	—	
	dB <A>	—	—	—	—	
Insulation material		PS				
Air filter		PP honeycomb (long life filter, anti-bacterial type)				
Protection device		Fuse				
Refrigerant control device		LEV				
Connectable outdoor unit		R410, CITY MULTI				
Diameter of refrigerant pipe (O.D.)	Liquid	in [mm]	3/8 [9.52] Flare	3/8 [9.52] Flare	3/8 [9.52] Flare	
	Gas	in [mm]	5/8 [15.88] Flare	5/8 [15.88] Flare	5/8 [15.88] Flare	
Field drain pipe size	in [mm]	O.D 1-1/4 [32]	O.D 1-1/4 [32]	O.D 1-1/4 [32]	O.D 1-1/4 [32]	
Standard attachment	Document, accessory	Installation Manual, Instruction Book				
Optional parts	Air outlet shutter plate	PAC-SJ37SP-E	PAC-SJ37SP-E	PAC-SJ37SP-E	PAC-SJ37SP-E	
	High efficiency filter element	PAC-SH59KF-E	PAC-SH59KF-E	PAC-SH59KF-E	PAC-SH59KF-E	
	Multi-function casement	PAC-SJ41TM-E	PAC-SJ41TM-E	PAC-SJ41TM-E	PAC-SJ41TM-E	
Remarks	Installation	Details on foundation work, duct work, insulation work, electrical wiring, power source switch, and other items shall be referred to the Installation Manual.				
*1 Nominal cooling conditions Indoor: 80°F D.B./67°F W.B [26.7°C D.B./19.4°C W.B] Outdoor: 95°F D.B. [35°C D.B.] Pipe length: 25 ft [7.6m] Level difference: 0 ft [0 m]		*2 Nominal heating conditions 70°F D.B. [21.1°C D.B.] 47°F D.B./43°F W.B [8.3°C D.B./6.1°C W.B] 25 ft [7.6m] 0 ft [0 m]		Unit converter kcal/h = kW × 860 BTU/h = kW × 3,412 cfm = m ³ /min × 35.31 lb = kg/0.4536		
Note: Due to continuing improvement, above specification may be subject to change without notice.					Above specification data is subject to rounding variation.	

3-2. SOUND PRESSURE LEVEL

PLFY-P•NEMU-E

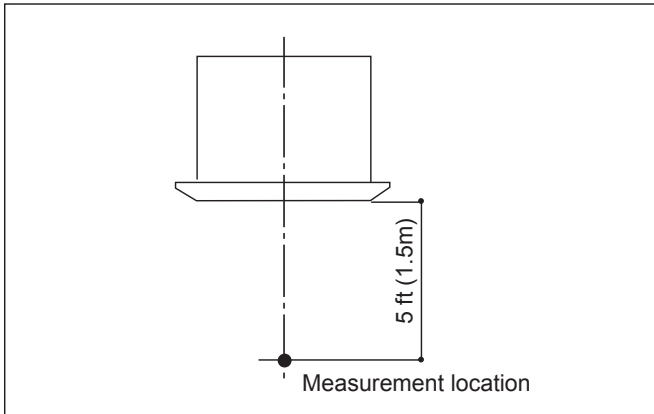

Note: Measured in anechoic room.

Sound pressure level in anechoic room: Low-Mid2-Mid1-High

	Sound pressure level dB (A)
PLFY-P08NEMU-E	27-29-30-31
PLFY-P12NEMU-E	27-29-30-31
PLFY-P15NEMU-E	28-29-30-31
PLFY-P18NEMU-E	28-30-31-32
PLFY-P24NEMU-E	28-31-34-37
PLFY-P30NEMU-E	28-32-35-38
PLFY-P36NEMU-E	35-38-41-44
PLFY-P48NEMU-E	36-39-42-45

3-3. NC CURVES

PLFY-P08NEMU-E

External Static Pressure: 0Pa [0.00in.WG]
Power Source: 208-230V 60Hz

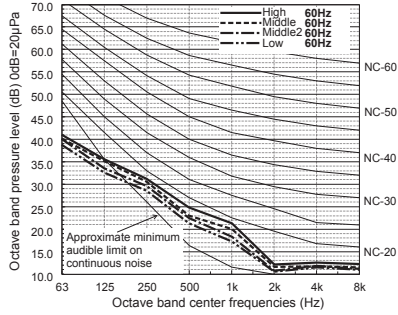

PLFY-P12NEMU-E

External Static Pressure: 0Pa [0.00in.WG]
Power Source: 208-230V 60Hz

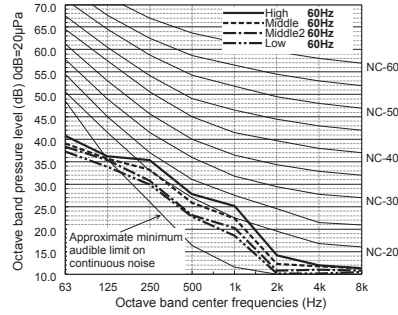

PLFY-P15NEMU-E

External Static Pressure: 0Pa [0.00in.WG]
Power Source: 208-230V 60Hz

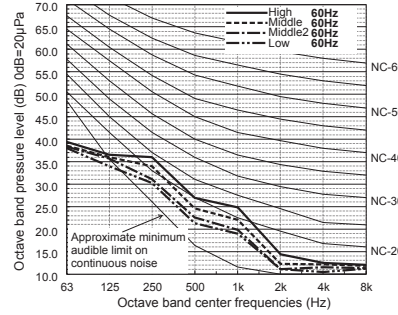

PLFY-P18NEMU-E

External Static Pressure: 0Pa [0.00in.WG]
Power Source: 208-230V 60Hz

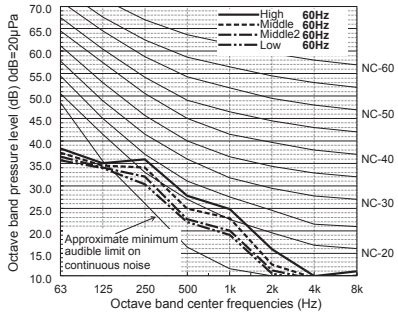

PLFY-P24NEMU-E

External Static Pressure: 0Pa [0.00in.WG]
Power Source: 208-230V 60Hz

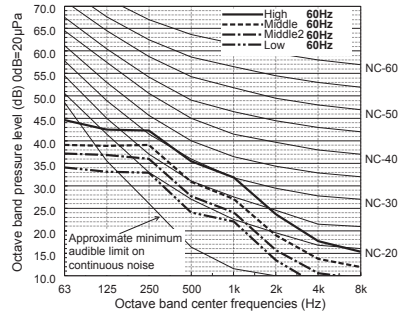

PLFY-P30NEMU-E

External Static Pressure: 0Pa [0.00in.WG]
Power Source: 208-230V 60Hz

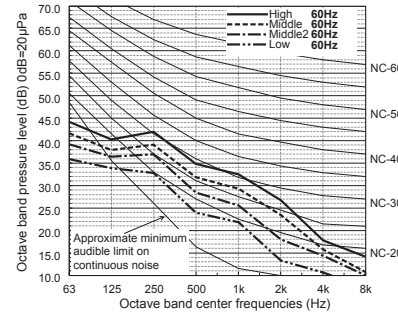

PLFY-P36NEMU-E

External Static Pressure: 0Pa [0.00in.WG]
Power Source: 208-230V 60Hz

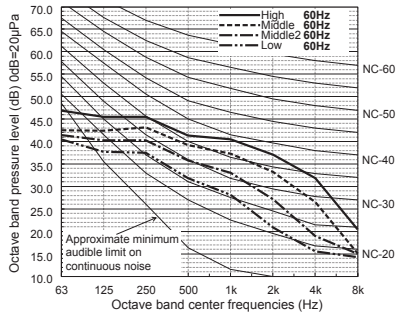

PLFY-P48NEMU-E

External Static Pressure: 0Pa [0.00in.WG]
Power Source: 208-230V 60Hz

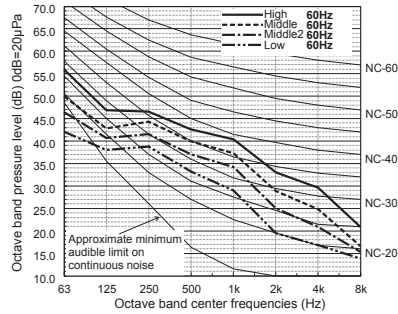

3-4. ELECTRICAL PARTS SPECIFICATIONS

Service Ref. Parts name	Symbol	PLFY-P08NEMU-E PLFY-P12NEMU-E	PLFY-P15NEMU-E	PLFY-P18NEMU-E	PLFY-P24NEMU-E	PLFY-P30NEMU-E	PLFY-P36NEMU-E PLFY-P48NEMU-E
Room temperature thermistor	TH21	Resistance 30°F/15.8 kΩ, 50°F/9.6 kΩ, 70°F/6.0 kΩ, 80°F/4.8 kΩ, 90°F/3.9 kΩ, 100°F/3.2 kΩ					
Liquid pipe thermistor	TH22	Resistance 30°F/15.8 kΩ, 50°F/9.6 kΩ, 70°F/6.0 kΩ, 80°F/4.8 kΩ, 90°F/3.9 kΩ, 100°F/3.2 kΩ					
Gas pipe thermistor	TH23	Resistance 30°F/15.8 kΩ, 50°F/9.6 kΩ, 70°F/6.0 kΩ, 80°F/4.8 kΩ, 90°F/3.9 kΩ, 100°F/3.2 kΩ					
Fuse (Indoor controller board)	FUSE	UL 6.3A 250 V AC					
Fan motor	MF	8-pole OUTPUT 50W					8-pole OUTPUT, 120W
Vane motor	MV	MSBPC20M04 12 V DC, 300Ω/phase					
Drain pump	DP	PLD-12230ME-1 INPUT 12/10.8W 24 ℓ /Hr					
Drain float switch	FS	Open/short detection					
Linear expansion valve	LEV	12 V DC Stepping motor drive port dimension ϕ 3.2 (0–2000pulse) EDM-40YGME				12 V DC Stepping motor drive port dimension ϕ 5.2 (0–2000pulse) EDM-80YGME	
Power supply terminal block	TB2	(L1, L2, GR) 330 V, 30 A					
Transmission terminal block	TB5	(M1, M2, S) 250 V, 20 A					
MA remote controller terminal block	TB15	(1, 2) 250 V, 10 A					

4-1. PLACEMENT OF THE AIR OUTLETS

• For this grille, the blowout direction comes in 11 patterns.

Also, by setting the remote controller to the appropriate settings, you can adjust the airflow and speed. Select the settings from Table1 according to the location in which you want to install the unit.

1) Decide on the pattern of the airflow direction.

<Table 1>

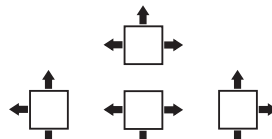
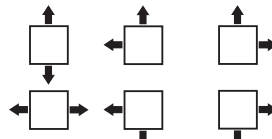
	4-direction	3-direction	2-direction
Blowout direction pattern	Pattern 1 Initial setting 	Pattern 4 One air outlet fully closed 	Pattern 6 2 air outlet fully closed 

Note: For 3 and 2-direction settings, please use the air outlet shutter plate (option).

2) According to the number of air outlets and height of the ceiling to install the unit, be sure to set up the switch (SW21) on the indoor controller board to the appropriate setting.

• Correspondence of ceiling heights to numbers of air outlets

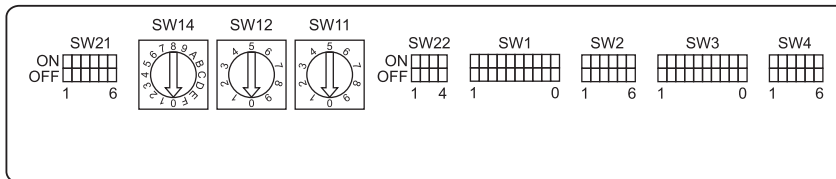

			PLFY-P08/12/15/18/24/30NEMU-E						PLFY-P36/48NEMU-E					
			Silent		Standard		High ceiling		Silent		Standard		High ceiling	
			SW21-1	SW21-2	SW21-1	SW21-2	SW21-1	SW21-2	SW21-1	SW21-2	SW21-1	SW21-2	SW21-1	SW21-2
			OFF	ON	OFF	OFF	ON	OFF	OFF	ON	OFF	OFF	ON	OFF
4 direction	SW21-3	OFF	8.2 ft [2.5 m]		8.9 ft [2.7 m]		11.5 ft [3.5 m]		8.9 ft [2.7 m]		10.5 ft [3.2 m]		14.8 ft [4.5 m]	
	SW21-4	ON	8.9 ft [2.7 m]		9.8 ft [3.0 m]		11.5 ft [3.5 m]		9.8 ft [3.0 m]		11.8 ft [3.6 m]		14.8 ft [4.5 m]	
3 direction	SW21-3	OFF	8.9 ft [2.7 m]		9.8 ft [3.0 m]		11.5 ft [3.5 m]		9.8 ft [3.0 m]		11.8 ft [3.6 m]		14.8 ft [4.5 m]	
	SW21-4	OFF	9.8 ft [3.0 m]		10.8 ft [3.3 m]		11.5 ft [3.5 m]		10.8 ft [3.3 m]		13.1 ft [4.0 m]		14.8 ft [4.5 m]	
2 direction	SW21-3	ON	9.8 ft [3.0 m]		10.8 ft [3.3 m]		11.5 ft [3.5 m]		10.8 ft [3.3 m]		13.1 ft [4.0 m]		14.8 ft [4.5 m]	
	SW21-4	OFF	10.8 ft [3.3 m]		11.5 ft [3.5 m]		11.5 ft [3.5 m]		10.8 ft [3.3 m]		13.1 ft [4.0 m]		14.8 ft [4.5 m]	

4-2. BRANCH DUCT HOLE AND FRESH AIR INTAKE HOLE

At the time of installation, use the duct holes (cut out) located at the positions shown in following diagram, as and when required.
 • A fresh air intake hole for the optional multi function casement can also be made.

Note:

The figures marked with * in the drawing below represent the dimensions of the main unit excluding those of the optional multi function casement.

When installing the optional multi function casement, add 5-5/16" (135 mm) to the dimensions marked on the figure.

When installing the branch ducts, be sure to insulate adequately.

Otherwise, condensation and dripping may occur.

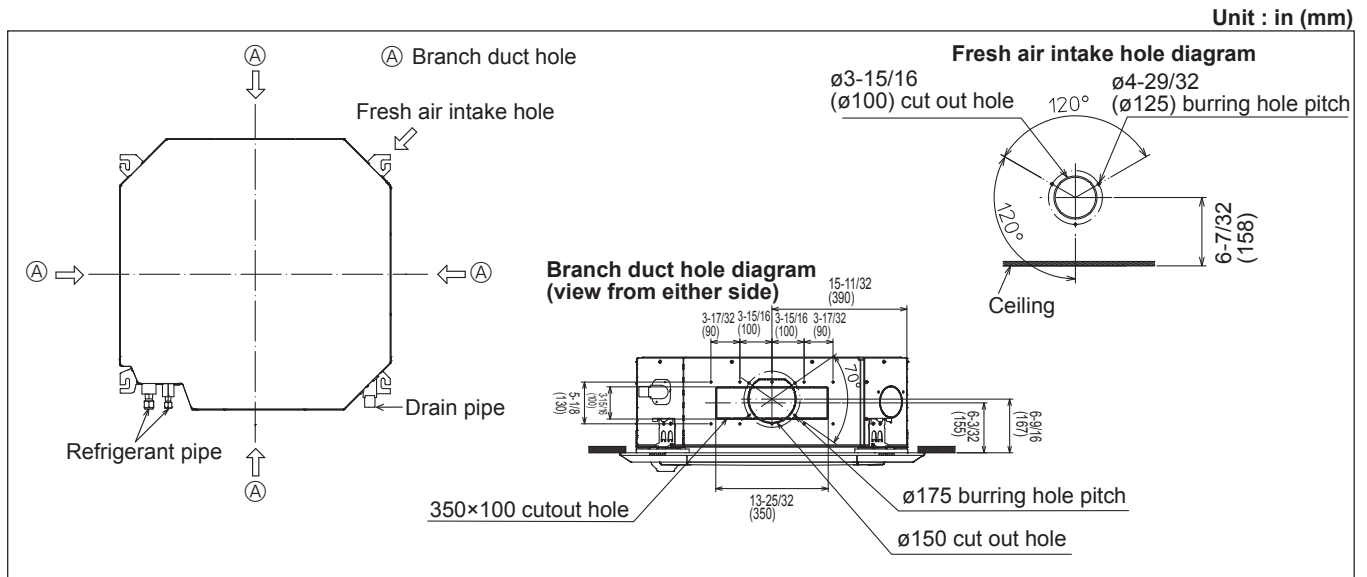

4-3. OPERATION IN CONJUNCTION WITH DUCT FAN (Booster fan)

• Whenever the indoor unit is operating, the duct fan also operates.

(1) Connect the optional multiple remote controller adapter (PAC-SA88HA-E) to the connector CN51 on the indoor controller board.

(2) Drive the relay after connecting the 12 V DC relay between the Yellow and Orange connector lines.

MB: Electromagnetic switch power relay for duct fan.

X: Auxiliary relay (For 12 V DC, coil rating: 1.0W or smaller)

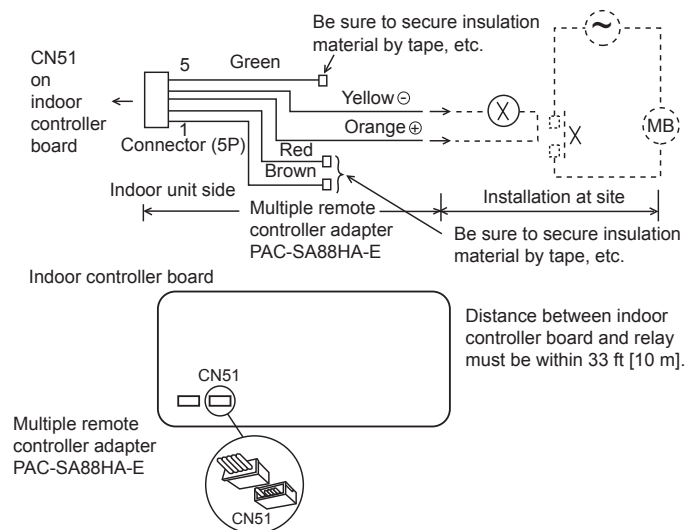

4-4. FRESH AIR INTAKE AMOUNT & STATIC PRESSURE CHARACTERISTICS

1 PLFY-P08/12/15/18/24/30NEMU-E

Taking air into the unit

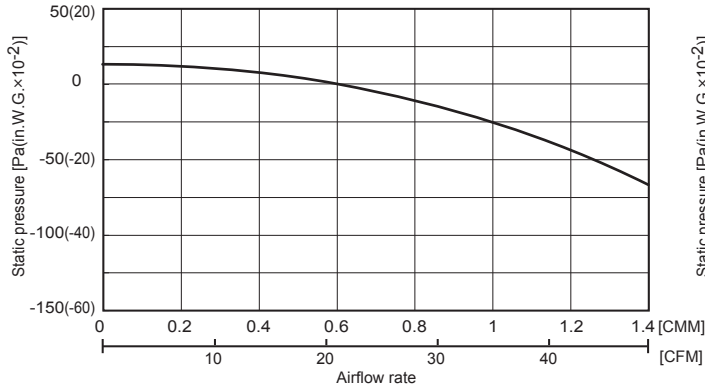

Multifunction casement + Standard filter

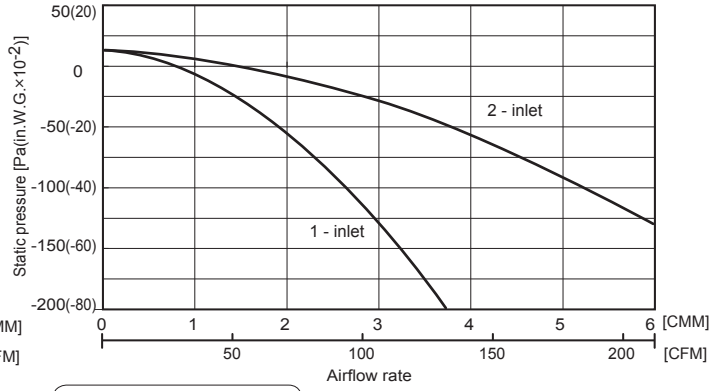

Multifunction casement + High efficiency filter

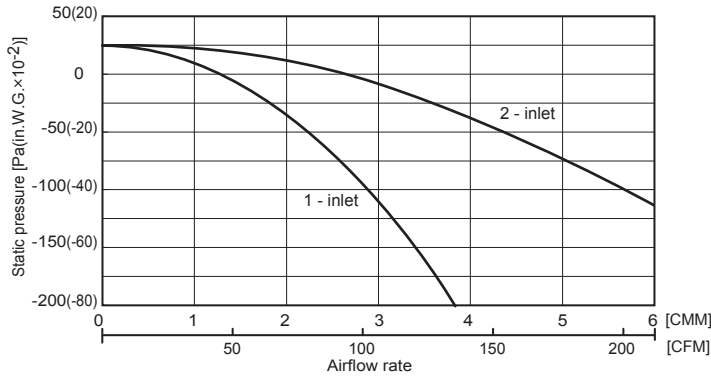

How to read curves

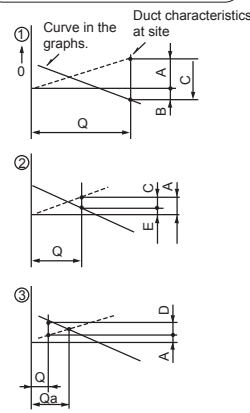

- Q...Designed amount of fresh air intake <CMM (CFM)>
- A...Static pressure loss of fresh air intake duct system with airflow amount Q <Pa (in.W.G. $\times 10^{-2}$)>
- B...Forced static pressure at air conditioner inlet with airflow amount Q <Pa (in.W.G. $\times 10^{-2}$)>
- C...Static pressure of booster fan with airflow amount Q <Pa (in.W.G. $\times 10^{-2}$)>
- D...Static pressure loss increase amount of fresh air intake duct system for airflow amount Q <Pa (in.W.G. $\times 10^{-2}$)>
- E...Static pressure of indoor unit with airflow amount Q <Pa (in.W.G. $\times 10^{-2}$)>
- Qa...Estimated amount of fresh air intake without D <CMM (CFM)>

2 PLFY-P36/48NEMU-E

Taking air into the unit

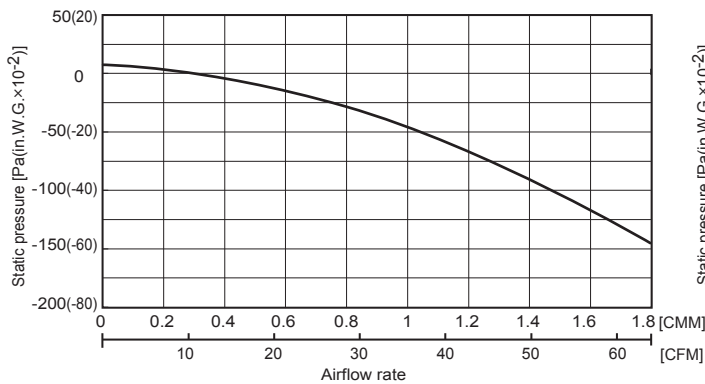

Multifunction casement + Standard filter

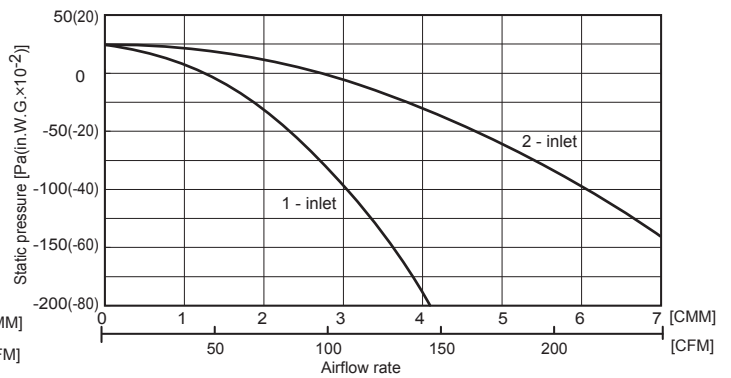

Multifunction casement + High efficiency filter

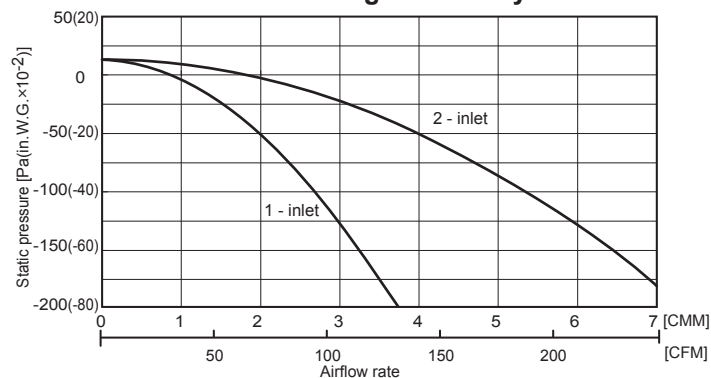

PLFY-P08NEMU-E
PLFY-P24NEMU-E

PLFY-P12NEMU-E
PLFY-P30NEMU-E

PLFY-P15NEMU-E
PLFY-P36NEMU-E

PLFY-P18NEMU-E
PLFY-P48NEMU-E

Unit: in (mm)

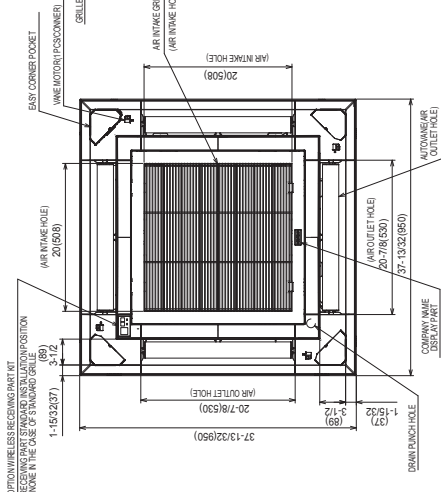
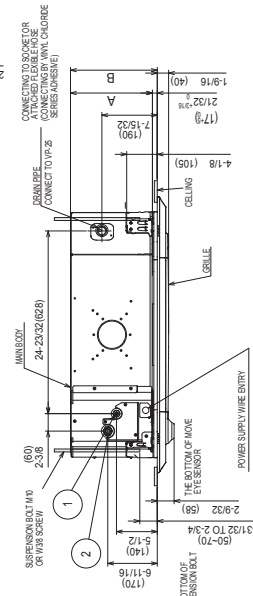
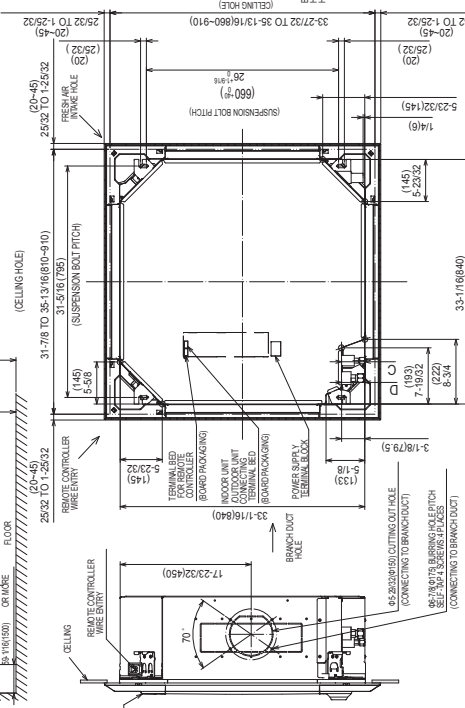
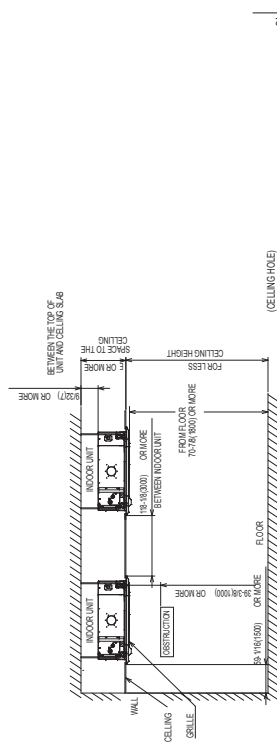
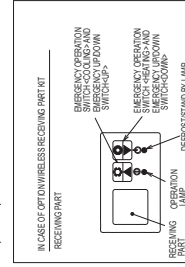
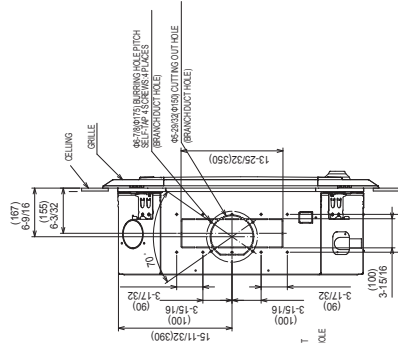
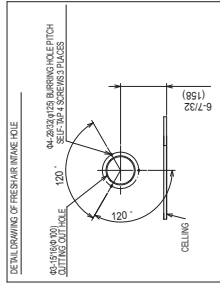

*IN CASE OF STANDARD GRILLE WITHOUT FAN MOTOR SENSOR EXCEPT IN THE CORNER OF THE ROOM, THE CONNECTION BY REMOTE CONTROLLER.

NOTE: PLEASE CHOOSE THE GRILLE FROM STANDARD GRILLE AUTO-GRILLE. REMEMBER THE SUSPENSION HOLE BY BARRING HOLE PITCH. SUPPORT MATERIAL WHICH RESISTS TO SPLITTING IN THE CASE WITHOUT CEILING MATERIAL. CONFIRM THE BARRING HOLE PITCH. (SEE THE DIMENSIONS OF THE GRILLE IN THE TECHNICAL DATA SHEET).
 1. CHECK THE POSITION OF THE SUSPENSION HOLE.
 2. CHECK THE POSITION OF THE SUSPENSION HOLE.
 3. CHECK THE POSITION OF THE SUSPENSION HOLE.
 4. CHECK THE POSITION OF THE SUSPENSION HOLE.
 5. CHECK THE POSITION OF THE SUSPENSION HOLE.
 6. CHECK THE POSITION OF THE SUSPENSION HOLE.
 7. CHECK THE POSITION OF THE SUSPENSION HOLE.
 8. CHECK THE POSITION OF THE SUSPENSION HOLE.
 9. CHECK THE POSITION OF THE SUSPENSION HOLE.
 10. CHECK THE POSITION OF THE SUSPENSION HOLE.
 11. CHECK THE POSITION OF THE SUSPENSION HOLE.
 12. CHECK THE POSITION OF THE SUSPENSION HOLE.
 13. CHECK THE POSITION OF THE SUSPENSION HOLE.
 14. CHECK THE POSITION OF THE SUSPENSION HOLE.
 15. CHECK THE POSITION OF THE SUSPENSION HOLE.
 16. CHECK THE POSITION OF THE SUSPENSION HOLE.
 17. CHECK THE POSITION OF THE SUSPENSION HOLE.
 18. CHECK THE POSITION OF THE SUSPENSION HOLE.
 19. CHECK THE POSITION OF THE SUSPENSION HOLE.
 20. CHECK THE POSITION OF THE SUSPENSION HOLE.
 21. CHECK THE POSITION OF THE SUSPENSION HOLE.
 22. CHECK THE POSITION OF THE SUSPENSION HOLE.
 23. CHECK THE POSITION OF THE SUSPENSION HOLE.
 24. CHECK THE POSITION OF THE SUSPENSION HOLE.
 25. CHECK THE POSITION OF THE SUSPENSION HOLE.
 26. CHECK THE POSITION OF THE SUSPENSION HOLE.
 27. CHECK THE POSITION OF THE SUSPENSION HOLE.
 28. CHECK THE POSITION OF THE SUSPENSION HOLE.
 29. CHECK THE POSITION OF THE SUSPENSION HOLE.
 30. CHECK THE POSITION OF THE SUSPENSION HOLE.
 31. CHECK THE POSITION OF THE SUSPENSION HOLE.
 32. CHECK THE POSITION OF THE SUSPENSION HOLE.
 33. CHECK THE POSITION OF THE SUSPENSION HOLE.
 34. CHECK THE POSITION OF THE SUSPENSION HOLE.
 35. CHECK THE POSITION OF THE SUSPENSION HOLE.
 36. CHECK THE POSITION OF THE SUSPENSION HOLE.
 37. CHECK THE POSITION OF THE SUSPENSION HOLE.
 38. CHECK THE POSITION OF THE SUSPENSION HOLE.
 39. CHECK THE POSITION OF THE SUSPENSION HOLE.
 40. CHECK THE POSITION OF THE SUSPENSION HOLE.
 41. CHECK THE POSITION OF THE SUSPENSION HOLE.
 42. CHECK THE POSITION OF THE SUSPENSION HOLE.
 43. CHECK THE POSITION OF THE SUSPENSION HOLE.
 44. CHECK THE POSITION OF THE SUSPENSION HOLE.
 45. CHECK THE POSITION OF THE SUSPENSION HOLE.
 46. CHECK THE POSITION OF THE SUSPENSION HOLE.
 47. CHECK THE POSITION OF THE SUSPENSION HOLE.
 48. CHECK THE POSITION OF THE SUSPENSION HOLE.
 49. CHECK THE POSITION OF THE SUSPENSION HOLE.
 50. CHECK THE POSITION OF THE SUSPENSION HOLE.
 51. CHECK THE POSITION OF THE SUSPENSION HOLE.
 52. CHECK THE POSITION OF THE SUSPENSION HOLE.
 53. CHECK THE POSITION OF THE SUSPENSION HOLE.
 54. CHECK THE POSITION OF THE SUSPENSION HOLE.
 55. CHECK THE POSITION OF THE SUSPENSION HOLE.
 56. CHECK THE POSITION OF THE SUSPENSION HOLE.
 57. CHECK THE POSITION OF THE SUSPENSION HOLE.
 58. CHECK THE POSITION OF THE SUSPENSION HOLE.
 59. CHECK THE POSITION OF THE SUSPENSION HOLE.
 60. CHECK THE POSITION OF THE SUSPENSION HOLE.
 61. CHECK THE POSITION OF THE SUSPENSION HOLE.
 62. CHECK THE POSITION OF THE SUSPENSION HOLE.
 63. CHECK THE POSITION OF THE SUSPENSION HOLE.
 64. CHECK THE POSITION OF THE SUSPENSION HOLE.
 65. CHECK THE POSITION OF THE SUSPENSION HOLE.
 66. CHECK THE POSITION OF THE SUSPENSION HOLE.
 67. CHECK THE POSITION OF THE SUSPENSION HOLE.
 68. CHECK THE POSITION OF THE SUSPENSION HOLE.
 69. CHECK THE POSITION OF THE SUSPENSION HOLE.
 70. CHECK THE POSITION OF THE SUSPENSION HOLE.
 71. CHECK THE POSITION OF THE SUSPENSION HOLE.
 72. CHECK THE POSITION OF THE SUSPENSION HOLE.
 73. CHECK THE POSITION OF THE SUSPENSION HOLE.
 74. CHECK THE POSITION OF THE SUSPENSION HOLE.
 75. CHECK THE POSITION OF THE SUSPENSION HOLE.
 76. CHECK THE POSITION OF THE SUSPENSION HOLE.
 77. CHECK THE POSITION OF THE SUSPENSION HOLE.
 78. CHECK THE POSITION OF THE SUSPENSION HOLE.
 79. CHECK THE POSITION OF THE SUSPENSION HOLE.
 80. CHECK THE POSITION OF THE SUSPENSION HOLE.
 81. CHECK THE POSITION OF THE SUSPENSION HOLE.
 82. CHECK THE POSITION OF THE SUSPENSION HOLE.
 83. CHECK THE POSITION OF THE SUSPENSION HOLE.
 84. CHECK THE POSITION OF THE SUSPENSION HOLE.
 85. CHECK THE POSITION OF THE SUSPENSION HOLE.
 86. CHECK THE POSITION OF THE SUSPENSION HOLE.
 87. CHECK THE POSITION OF THE SUSPENSION HOLE.
 88. CHECK THE POSITION OF THE SUSPENSION HOLE.
 89. CHECK THE POSITION OF THE SUSPENSION HOLE.
 90. CHECK THE POSITION OF THE SUSPENSION HOLE.
 91. CHECK THE POSITION OF THE SUSPENSION HOLE.
 92. CHECK THE POSITION OF THE SUSPENSION HOLE.
 93. CHECK THE POSITION OF THE SUSPENSION HOLE.
 94. CHECK THE POSITION OF THE SUSPENSION HOLE.
 95. CHECK THE POSITION OF THE SUSPENSION HOLE.
 96. CHECK THE POSITION OF THE SUSPENSION HOLE.
 97. CHECK THE POSITION OF THE SUSPENSION HOLE.
 98. CHECK THE POSITION OF THE SUSPENSION HOLE.
 99. CHECK THE POSITION OF THE SUSPENSION HOLE.
 100. CHECK THE POSITION OF THE SUSPENSION HOLE.

*CHARACTERISTICS OF EACH MODEL AS FOLLOWS
 P L F Y P A B C D E F

PANEL	(1)	(2)	(3)	A	B	C	D	E	F
0p-16	REFRIGERANT PIPING FLARED CONNECTION 1/4"	REFRIGERANT PIPING FLARED CONNECTION 1/4"	REFRIGERANT PIPING FLARED CONNECTION 1/4"	9-1/2 (241)	10-5/32 (270-5)	3-7/8 (97-5)	16-7/16 (420)	17-1/2 (442)	17-1/2 (442)
2400	REFRIGERANT PIPING FLARED CONNECTION 1/2"	REFRIGERANT PIPING FLARED CONNECTION 1/2"	REFRIGERANT PIPING FLARED CONNECTION 1/2"	11-1/8 (291)	11-3/32 (293)	3-1/8 (78)	17-1/2 (442)	17-1/2 (442)	17-1/2 (442)
3048	REFRIGERANT PIPING FLARED CONNECTION 3/8"	REFRIGERANT PIPING FLARED CONNECTION 3/8"	REFRIGERANT PIPING FLARED CONNECTION 3/8"	11-1/8 (291)	11-3/32 (293)	3-1/8 (78)	17-1/2 (442)	17-1/2 (442)	17-1/2 (442)

7

REFRIGERANT SYSTEM DIAGRAM

PLFY-P08NEMU-E
PLFY-P24NEMU-E

PLFY-P12NEMU-E
PLFY-P30NEMU-E

PLFY-P15NEMU-E
PLFY-P36NEMU-E

PLFY-P18NEMU-E
PLFY-P48NEMU-E

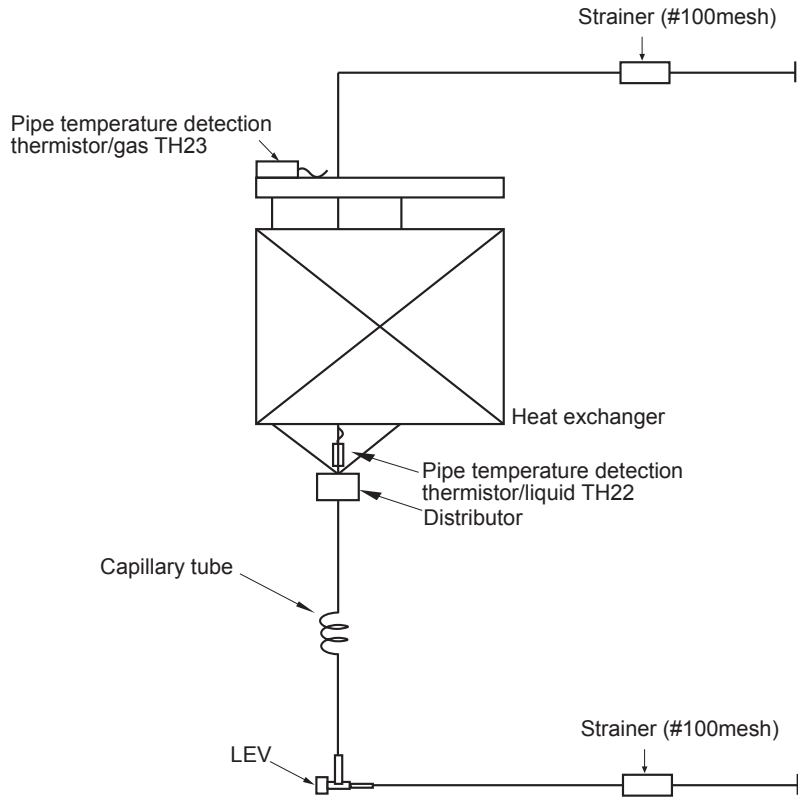

Unit: in [mm]

Model	PLFY-P08/12/15/18NEMU-E	PLFY-P24/30/36/48NEMU-E
Gas pipe	$\phi 1/2$ [12.7]	$\phi 5/8$ [15.88]
Liquid pipe	$\phi 1/4$ [6.35]	$\phi 3/8$ [9.52]

INDOOR UNIT CONTROL

8-1. COOL OPERATION

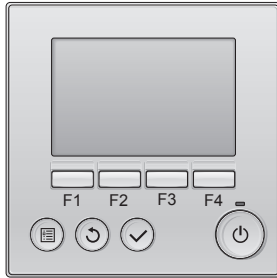

<How to operate>

- ① Press [POWER] button.
- ② Press [F1] button to display COOL.
- ③ Press [F2] [F3] button to set the set temperature.

NOTE: The settable temperature range varies with the model of outdoor units and remote controller.

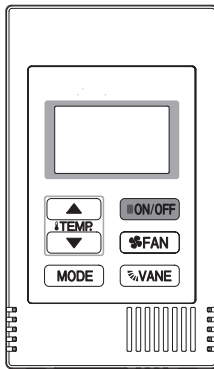

<How to operate>

- ① Press POWER ON/OFF button.
- ② Press the operation MODE button to display COOL.
- ③ Press the TEMP. button to set the set temperature.

NOTE: The set temperature changes 1°F when the [DOWN] or [UP] button is pressed one time. Cooling 67 to 87°F

Control Mode	Control Details	Remarks																
1. Temperature adjustment function	<p>1-1. Determining temperature adjustment function (Function to prevent restarting for 3 minutes)</p> <ul style="list-style-type: none"> • Room temperature \geq Set temperature + 2°F ...Thermo-ON • Room temperature \leq Set temperature ...Thermo-OFF <p>1-2. Anti-freeze control</p> <ul style="list-style-type: none"> ■ Condition to detect When the pipe temperature detection thermistor/liquid (TH22) detects 32°F or less in 16 minutes from thermo-ON, the anti-freeze control initiates, and the unit enters to the thermo-OFF. ■ Condition to release The timer which prevents reactivating is set for 3 minutes, and anti-freeze control is cancelled when any one of the following conditions has been satisfied: <ol style="list-style-type: none"> ① Pipe temperature detection thermistor/liquid (TH22) reaches 50°F or above. ② The condition of thermo-OFF has been completed by the thermostat. ③ The operation has changed to a mode other than COOLING. 	<ul style="list-style-type: none"> • The ON/OFF commands by the indoor unit thermostatic control are not an ON/OFF commands to the compressor but an open/close commands to the linear expansion valve. (The compressor stops only when the thermostatic control for all the indoor units connected to the same outdoor unit turns OFF.) 																
2. Fan	<p>By the remote controller setting (switch of 4 speeds+Auto)</p> <table border="1" style="width: 100%;"> <thead> <tr> <th>Type</th> <th>Fan speed notch</th> </tr> </thead> <tbody> <tr> <td>4 speeds + Auto type</td> <td> </td> </tr> </tbody> </table> <p>When [Auto] is set, fan speed is changed depending on the value of: $\Delta T = \text{Room temperature} - \text{Set temperature}$</p> <table border="1" style="width: 100%;"> <thead> <tr> <th>High</th> <th>Med2</th> <th>Med1</th> <th>Low</th> </tr> </thead> <tbody> <tr> <td colspan="4" style="text-align: center;"> </td> </tr> <tr> <td colspan="4" style="text-align: center;">ΔT</td> </tr> </tbody> </table>	Type	Fan speed notch	4 speeds + Auto type		High	Med2	Med1	Low					ΔT				
Type	Fan speed notch																	
4 speeds + Auto type																		
High	Med2	Med1	Low															
ΔT																		

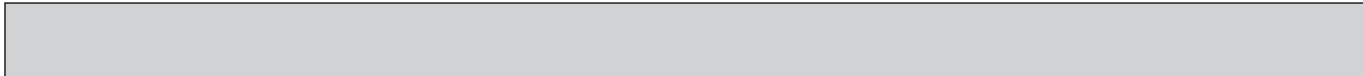

Control Mode	Control Details	Remarks
3. Drain pump	<p>3-1. Drain pump control</p> <ul style="list-style-type: none"> The drain pump will always run when the unit is in COOL or DRY mode. (Regardless of the thermo ON/OFF) Whenever the operation is changed over to the other modes (including Stop), the drain pump will stop pumping after approximately 3 minutes. <p>Float switch control</p> <ul style="list-style-type: none"> Float switch control judges whether the sensor is in the air or in the water by turning the float switch ON/OFF. In the water: Detected that the float switch is ON for 15 seconds. In the air: Detected that the float switch is OFF for 15 seconds 	
4. Vane (up/down vane change)	<p>(1) The initial vane setting for COOL mode will be the horizontal position.</p> <p>(2) Vane position: Horizontal → Downward A → Downward B → Downward C → Downward D → Swing → Auto</p> <p>(3) Restriction of the downward vane setting If the vane position is set to Downward A/B/C/D in [Med1], [Med2], or [Low], the vane will return to the horizontal position after 1 hour has passed.</p>	<ul style="list-style-type: none"> "ONLY 1 Hr" appears on the wired remote controller.

8-2. DRY OPERATION

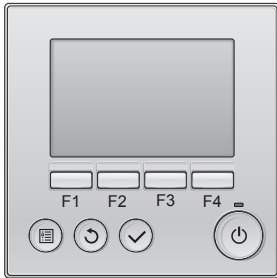

<How to operate>

- ① Press button.
- ② Press [F1] button to display DRY.
- ③ Press [F2] [F3] button to set the set temperature.

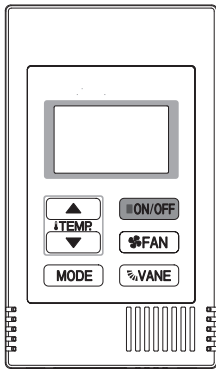

<How to operate>

- ① Press POWER ON/OFF button.
- ② Press the operation MODE button to display DRY.
- ③ Press the TEMP. button to set the set temperature.

NOTE: The set temperature changes 1°F when the or button is pressed one time. Dry 67 to 87°F

Control Mode	Control Details	Remarks																														
1. Temperature adjustment function	1-1. Determining temperature adjustment function (Function to prevent restarting for 3 minutes) Setting the Dry thermo by the thermostat signal and the room temperature (TH21). Dry thermo-ON Room temperature \geq Set temperature + 2°F Dry thermo-OFF Room temperature \leq Set temperature																															
	<table border="1"> <thead> <tr> <th rowspan="2">Room temperature</th> <th colspan="2">3 minutes passed since starting operation</th> <th rowspan="2">Dry thermo-ON time (min)</th> <th rowspan="2">Dry thermo-OFF time (min)</th> </tr> <tr> <th>Thermostat signal</th> <th>Room temperature (T1)</th> </tr> </thead> <tbody> <tr> <td rowspan="4">Over 64°F</td> <td rowspan="4">ON</td> <td>T1 \geq 83°F</td> <td>9</td> <td>3</td> </tr> <tr> <td>83°F > T1 \geq 79°F</td> <td>7</td> <td>3</td> </tr> <tr> <td>79°F > T1 \geq 75°F</td> <td>5</td> <td>3</td> </tr> <tr> <td>75°F > T1</td> <td>3</td> <td>3</td> </tr> <tr> <td>Below 64°F</td> <td>OFF</td> <td>Unconditional</td> <td>3</td> <td>10</td> </tr> <tr> <td colspan="5" style="text-align: center;">Dry thermo OFF</td> </tr> </tbody> </table>	Room temperature	3 minutes passed since starting operation		Dry thermo-ON time (min)	Dry thermo-OFF time (min)	Thermostat signal	Room temperature (T1)	Over 64°F	ON	T1 \geq 83°F	9	3	83°F > T1 \geq 79°F	7	3	79°F > T1 \geq 75°F	5	3	75°F > T1	3	3	Below 64°F	OFF	Unconditional	3	10	Dry thermo OFF				
Room temperature	3 minutes passed since starting operation		Dry thermo-ON time (min)	Dry thermo-OFF time (min)																												
	Thermostat signal	Room temperature (T1)																														
Over 64°F	ON	T1 \geq 83°F	9	3																												
		83°F > T1 \geq 79°F	7	3																												
		79°F > T1 \geq 75°F	5	3																												
		75°F > T1	3	3																												
Below 64°F	OFF	Unconditional	3	10																												
Dry thermo OFF																																
	1-2. Anti-freeze prevention control No control function																															
2. Fan	Indoor fan operation controlled depends on the compressor conditions. <table border="1"> <thead> <tr> <th>Dry thermo</th> <th colspan="2">Fan speed notch</th> </tr> </thead> <tbody> <tr> <td>ON</td> <td colspan="2">[Low]</td> </tr> <tr> <td rowspan="2">OFF</td> <td>Excluding the following</td> <td>Stop</td> </tr> <tr> <td>Room temp. < 64°F</td> <td>[Low]</td> </tr> </tbody> </table> Note: Fan speed change is not allowed during DRY operation.	Dry thermo	Fan speed notch		ON	[Low]		OFF	Excluding the following	Stop	Room temp. < 64°F	[Low]																				
Dry thermo	Fan speed notch																															
ON	[Low]																															
OFF	Excluding the following	Stop																														
	Room temp. < 64°F	[Low]																														
3. Drain pump	Operates as it would in COOLING operation.																															
4. Vane (up/down vane change)	Settings are the same in DRY operation as they are in COOL operation.																															

8-3. FAN OPERATION

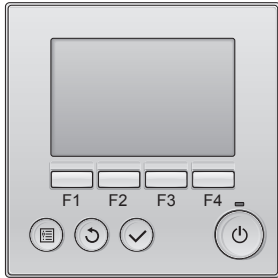

<How to operate>

- ① Press button.
- ② Press [F1] button to display FAN.

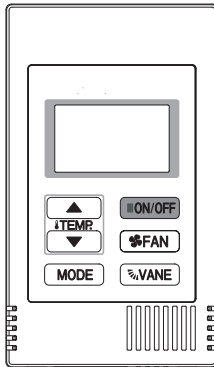

<How to operate>

- ① Press POWER ON/OFF button.
- ② Press the operation MODE button to display FAN.

Control Mode	Control Details	Remarks				
1. Temperature adjustment function	<p>Set by remote controller.</p> <table border="1" style="width: 100%;"> <thead> <tr> <th>Type</th> <th>Fan speed notch</th> </tr> </thead> <tbody> <tr> <td>4 speeds + Auto type</td> <td> </td> </tr> </tbody> </table> <p>When [Auto] is set, fan speed becomes [Low].</p>	Type	Fan speed notch	4 speeds + Auto type		
Type	Fan speed notch					
4 speeds + Auto type						
2. Drain pump	<p>2-1. Drain pump control The drain pump turns ON for the specified amount of time when any of the following conditions has been satisfied:</p> <ul style="list-style-type: none"> ① ON for 3 minutes after the operation mode is switched from COOL or DRY to another operation mode (FAN). ② ON for 6 minutes after the float switch is submerged in the water when the float switch control judges the sensor is in the water. <hr/> <p>2-2. Float switch control</p> <ul style="list-style-type: none"> • Float switch control judges whether the sensor is in the air or in the water by turning the float switch ON/OFF. In the water : Detected that the float switch is ON for 15 seconds. In the air : Detected that the float switch is OFF for 15 seconds. 	<ul style="list-style-type: none"> • Operates as it would in COOL operation. 				
3. Vane (up/down vane change)	Same as the control performed during the COOL operation, but with no restriction on the vane's downward blow setting					

8-4. HEAT OPERATION

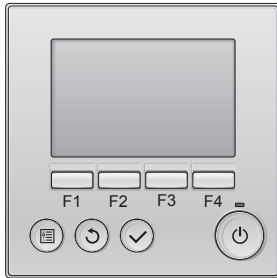

<How to operate>

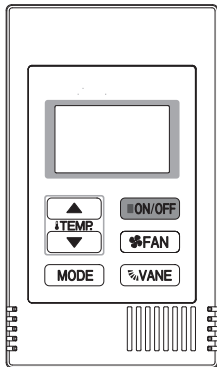

- ① Press [POWER] button.
- ② Press [F1] button to display HEAT.
- ③ Press [F2] [F3] button to set the set temperature.

NOTE: The settable temperature range varies with the model of outdoor units and remote controller.



<How to operate>

- ① Press POWER ON/OFF button.
- ② Press the operation MODE button to display HEAT.
- ③ Press the TEMP. button to set the set temperature.

NOTE: The set temperature changes 1°F when the  or  button is pressed one time. Heating 63 to 83°F

Control Mode	Control Details	Remarks				
1. Temperature adjustment function	1-1. Determining temperature adjustment function (Function to prevent restarting for 3 minutes) <ul style="list-style-type: none"> • Room temperature \leq Set temperature -2°F ...Thermo-ON • Room temperature \geq Set temperature ...Thermo-OFF 					
2. Fan	<p>By the remote controller setting (switch of 4 speeds+Auto)</p> <table border="1" style="width: 100%;"> <thead> <tr> <th>Type</th> <th>Fan speed notch</th> </tr> </thead> <tbody> <tr> <td>4 speeds + Auto type</td> <td> </td> </tr> </tbody> </table> <p>When [Auto] is set, fan speed is changed depending on the value of: $\Delta T = \text{Set temperature} - \text{Room temperature}$</p> <p>Give priority to under-mentioned controlled mode</p> <p>2-1. Hot adjust mode 2-2. Residual heat exclusion mode 2-3. Thermo-OFF mode (When the compressor off by the temperature adjustment function) 2-4. Cool air prevention mode (Defrosting mode)</p>	Type	Fan speed notch	4 speeds + Auto type		
Type	Fan speed notch					
4 speeds + Auto type						

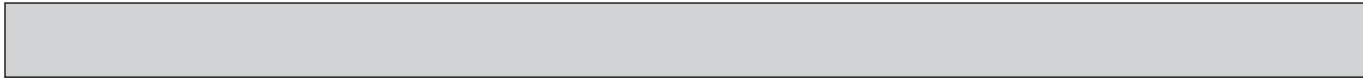

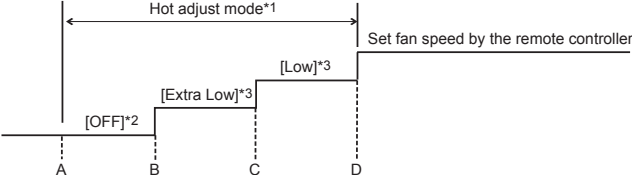
Control Mode	Control Details	Remarks															
<p>2. Fan</p>	<p>2-1. Hot adjust mode The fan controller becomes the hot adjust mode for the any of the following conditions.</p> <ol style="list-style-type: none"> ① When starting the HEAT operation ② When the temperature adjustment function changes from OFF to ON. ③ When release the HEAT defrosting operation  <p>A: Hot adjust mode starts. B: 5 minutes have passed since the condition A or the indoor liquid pipe temperature reached 86°F or more. C: 5 minutes have passed since the condition A or the indoor liquid pipe temperature reached 95°F or more. D: 2minutes have passed since the condition C. (Terminating the hot adjust mode)</p> <table border="1" data-bbox="1034 740 1513 878"> <thead> <tr> <th colspan="2"></th> <th colspan="2">DIP SW 1-8</th> </tr> <tr> <th colspan="2"></th> <th>ON</th> <th>OFF</th> </tr> </thead> <tbody> <tr> <td rowspan="2">DIP SW 1-7</td> <td>ON</td> <td>B to C [Extra Low] C to D [Low]</td> <td>B to C [Low] C to D [Low]</td> </tr> <tr> <td>OFF</td> <td>B to C [Setting airflow] C to D [Setting airflow]</td> <td>B to C [Extra Low] C to D [Low] Note: Initial setting</td> </tr> </tbody> </table> <p>2-2. Residual heat exclusion mode When the condition changes the auxiliary heater ON to OFF (temperature adjustment function, or operation stop, etc), the indoor fan operates in [Low] mode for 1 minute.</p> <p>2-3. Thermo-OFF mode When the temperature adjustment function changes to OFF, the indoor fan operates in [Extra low].</p> <p>2-4. Heat defrosting mode The indoor fan stops.</p>			DIP SW 1-8				ON	OFF	DIP SW 1-7	ON	B to C [Extra Low] C to D [Low]	B to C [Low] C to D [Low]	OFF	B to C [Setting airflow] C to D [Setting airflow]	B to C [Extra Low] C to D [Low] Note: Initial setting	<p>*1 "STAND BY" will be displayed during the hot adjust mode.</p> <p>*2 The step change of A to B will not be performed at the first thermo-ON mode since the HEAT operation has started.</p> <p>*3 The fan speed varies according to the setting of DIP SW1-7 and 1-8 as shown in the table below.</p> <p>• This control is same for the model without auxiliary heater.</p>
		DIP SW 1-8															
		ON	OFF														
DIP SW 1-7	ON	B to C [Extra Low] C to D [Low]	B to C [Low] C to D [Low]														
	OFF	B to C [Setting airflow] C to D [Setting airflow]	B to C [Extra Low] C to D [Low] Note: Initial setting														
<p>3. Drain pump</p>	<p>3-1. Drain pump control The drain pump turns ON for the specified amount of time when any of the following conditions has been satisfied:</p> <ol style="list-style-type: none"> ① ON for 3 minutes after the operation mode is switched from COOL or DRY to another operation mode (FAN). ② ON for 6 minutes after the float switch is submerged in the water when the float switch control judges the sensor is in the water. <p>3-2. Float switch control</p> <ul style="list-style-type: none"> • Float switch control judges whether the sensor is in the air or in the water by turning the float switch ON/OFF. <p>In the water: Detected that the float switch is ON for 15 seconds. In the air : Detected that the float switch is OFF for 15 seconds.</p>	<p>• Operates as it would in COOL operation.</p>															
<p>4. Vane control (Up/down vane change)</p>	<p>(1) Initial setting: OFF → HEAT…[last setting] When the last setting is [Swing] … [Downward D] When changing the mode from exception of HEAT to HEAT operation …[Downward D]</p> <p>(2) Vane position: Horizontal →Downward A →Downward B →Downward C→Downward D→Swing→Auto</p> <p>(3) Restriction of vane position</p> <ol style="list-style-type: none"> ① The vane is horizontally fixed for the following modes. (The control by the remote controller is temporally invalidated and control by the unit.) <ul style="list-style-type: none"> • Thermo-OFF • Hot adjust [Extra low] mode • Heat defrost mode 																

8-5. AUTO OPERATION [AUTOMATIC COOL/HEAT CHANGE OVER OPERATION]

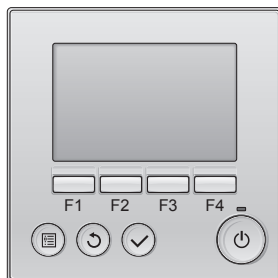

<How to operate>

- ① Press button.
 - ② Press [F1] button to display AUTO.
 - ③ Press [F2] [F3] button to set the set temperature.
- NOTE:** The settable temperature range varies with the model of outdoor units and remote controller.

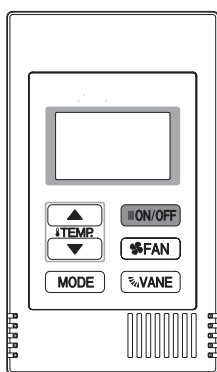

<How to operate>

- ① Press POWER ON/OFF button.
 - ② Press the operation MODE button to display AUTO.
 - ③ Press the TEMP. button to set the set temperature.
- NOTE:** The set temperature changes 1°F when the or button is pressed one time. Automatic 67 to 83°F

Control Mode	Control Details	Remarks
1. Initial value of operation mode	HEAT mode for room temperature < Set temperature COOL mode for room temperature ≥ Set temperature	
2. Mode change	(1) HEAT mode → COOL mode Room temperature ≥ Set temperature + 3°F or 3 minutes have passed. (2) COOL mode → HEAT mode Room temperature ≤ Set temperature - 3°F or 3 minutes have passed.	
3. COOL mode	Operates as it would in COOL operation.	
4. HEAT mode	Operates as it would in HEAT operation.	

8-6. WHEN UNIT IS STOPPED CONTROL MODE

Control Mode	Control Details	Remarks
1. Drain pump	1-1. Drain pump control The drain pump turns ON for the specified amount of time when any of the following conditions has been satisfied: ① ON for 3 minutes after the operation mode is switched from COOL or DRY to another operation mode (FAN). ② ON for 6 minutes after the float switch is submerged in the water when the float switch control judges the sensor is in the water.	
	1-2. Float switch control • Float switch control judges whether the sensor is in the air or in the water by turning the float switch ON/OFF. In the water : Detected that the float switch is ON for 15 seconds. In the air : Detected that the float switch is OFF for 15 seconds.	• Operates as it would in COOL operation.

9

TROUBLESHOOTING

9-1. HOW TO CHECK THE PARTS

PLFY-P08NEMU-E

PLFY-P12NEMU-E

PLFY-P15NEMU-E

PLFY-P18NEMU-E

PLFY-P24NEMU-E

PLFY-P30NEMU-E

PLFY-P36NEMU-E

PLFY-P48NEMU-E

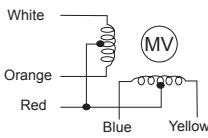
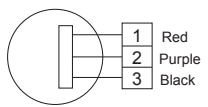
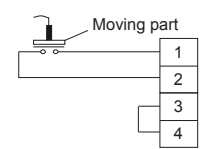
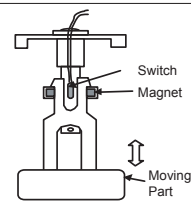
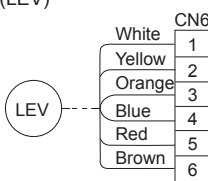
Parts name	Check points												
Room temperature detection thermistor (TH21) Pipe temperature detection thermistor/liquid (TH22) Pipe temperature detection thermistor/gas (TH23)	Disconnect the connector then measure the resistance with a tester. (At the ambient temperature 50 to 86°F) <table border="1" style="margin-left: 20px;"> <thead> <tr> <th>Normal</th> <th>Abnormal</th> </tr> </thead> <tbody> <tr> <td>4.3 to 9.6 kΩ</td> <td>Open or short</td> </tr> </tbody> </table> Refer to "9-1-1. Thermistor".			Normal	Abnormal	4.3 to 9.6 kΩ	Open or short						
Normal	Abnormal												
4.3 to 9.6 kΩ	Open or short												
Fan motor (MF)	Refer to "9-1-3. DC Fan motor (fan motor/indoor controller board)".												
Vane motor (MV) 	Measure the resistance between the terminals with a tester. (At the ambient temperature of 68 to 86°F) <table border="1" style="margin-left: 20px;"> <thead> <tr> <th>Connector</th> <th>Normal</th> <th>Abnormal</th> </tr> </thead> <tbody> <tr> <td>Red–Yellow (⑤–③, ⑩–⑥, ⑮–⑬, ⑳–⑱)</td> <td rowspan="5" style="text-align: center;">300 Ω</td> <td rowspan="5" style="text-align: center;">Open or short</td> </tr> <tr> <td>Red–Blue (⑤–①, ⑩–⑥, ⑮–⑪, ⑳–⑱)</td> </tr> <tr> <td>Red–Orange (⑤–④, ⑩–⑨, ⑮–⑭, ⑳–⑱)</td> </tr> <tr> <td>Red–White (⑤–②, ⑩–⑦, ⑮–⑲, ⑳–⑱)</td> </tr> <tr> <td>Red–White (⑤–②, ⑩–⑦, ⑮–⑲, ⑳–⑱)</td> </tr> </tbody> </table>			Connector	Normal	Abnormal	Red–Yellow (⑤–③, ⑩–⑥, ⑮–⑬, ⑳–⑱)	300 Ω	Open or short	Red–Blue (⑤–①, ⑩–⑥, ⑮–⑪, ⑳–⑱)	Red–Orange (⑤–④, ⑩–⑨, ⑮–⑭, ⑳–⑱)	Red–White (⑤–②, ⑩–⑦, ⑮–⑲, ⑳–⑱)	Red–White (⑤–②, ⑩–⑦, ⑮–⑲, ⑳–⑱)
Connector	Normal	Abnormal											
Red–Yellow (⑤–③, ⑩–⑥, ⑮–⑬, ⑳–⑱)	300 Ω	Open or short											
Red–Blue (⑤–①, ⑩–⑥, ⑮–⑪, ⑳–⑱)													
Red–Orange (⑤–④, ⑩–⑨, ⑮–⑭, ⑳–⑱)													
Red–White (⑤–②, ⑩–⑦, ⑮–⑲, ⑳–⑱)													
Red–White (⑤–②, ⑩–⑦, ⑮–⑲, ⑳–⑱)													
Drain pump (DP) 	<ol style="list-style-type: none"> ① Check if the drain float switch works properly. ② Check if the drain pump works and drains water properly in cooling operation. ③ If no water drains, confirm that the check code 2502 will not be displayed 10 minutes after the operation starts. Note: The drain pump for this model is driven by the internal DC motor of controller board, so it is not possible to measure the resistance between the terminals. Normal Red–Black: Input 13 V DC → The fan starts to rotate. Purple–Black: Abnormal (check code 2502) if it outputs 0–13 V square wave (5 pulses/rotation), and the number of rotation is not normal.												
Drain float switch (FS) 	Measure the resistance between the terminals using a tester. <table border="1" style="margin-left: 20px;"> <thead> <tr> <th>State of moving part</th> <th>Normal</th> <th>Abnormal</th> </tr> </thead> <tbody> <tr> <td>UP</td> <td>Short</td> <td>Other than short</td> </tr> <tr> <td>DOWN</td> <td>Open</td> <td>Other than open</td> </tr> </tbody> </table> 			State of moving part	Normal	Abnormal	UP	Short	Other than short	DOWN	Open	Other than open	
State of moving part	Normal	Abnormal											
UP	Short	Other than short											
DOWN	Open	Other than open											
Linear expansion valve (LEV) 	Disconnect the connector then measure the resistance with a tester. (At the coil temperature 50 to 86°F) <table border="1" style="margin-left: 20px;"> <thead> <tr> <th>Connector</th> <th>Normal</th> <th>Abnormal</th> </tr> </thead> <tbody> <tr> <td>White–Red</td> <td rowspan="4" style="text-align: center;">200 Ω ± 10%</td> <td rowspan="4" style="text-align: center;">Open or short</td> </tr> <tr> <td>Yellow–Brown</td> </tr> <tr> <td>Orange–Red</td> </tr> <tr> <td>Blue–Brown</td> </tr> </tbody> </table> Refer to "9-1-2. Linear expansion valve".			Connector	Normal	Abnormal	White–Red	200 Ω ± 10%	Open or short	Yellow–Brown	Orange–Red	Blue–Brown	
Connector	Normal	Abnormal											
White–Red	200 Ω ± 10%	Open or short											
Yellow–Brown													
Orange–Red													
Blue–Brown													

9-1-1. Thermistor

<Thermistor characteristic graph>

Thermistor for lower temperature

Room temperature detection thermistor (TH21)
 Pipe temperature detection thermistor/liquid (TH22)
 Pipe temperature detection thermistor/gas (TH23)

Thermistor $R_0=15 \text{ k}\Omega \pm 3\%$
 Fixed number of $B=3480 \pm 2\%$

$$R_t = 15 \exp \left\{ 3480 \left(\frac{1}{273 + (t-32)/1.8} - \frac{1}{273} \right) \right\}$$

30°F	15.8 kΩ
50°F	9.6 kΩ
70°F	6.0 kΩ
80°F	4.8 kΩ
90°F	3.9 kΩ
100°F	3.2 kΩ

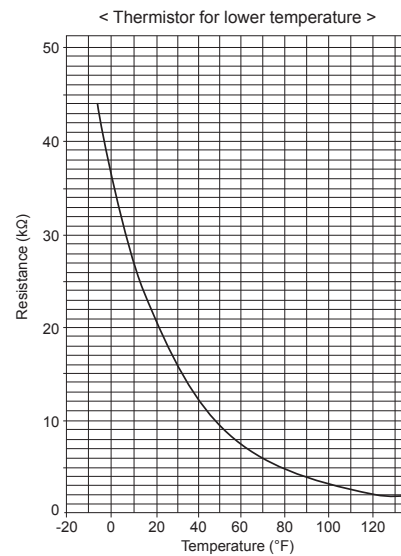

9-1-2. Linear expansion valve

① Operation summary of the linear expansion valve

- Linear expansion valve opens/closes through stepping motor after receiving the pulse signal from the indoor controller board.
- Valve position can be changed in proportion to the number of pulse signals.

<Connection between the indoor controller board and the linear expansion valve>

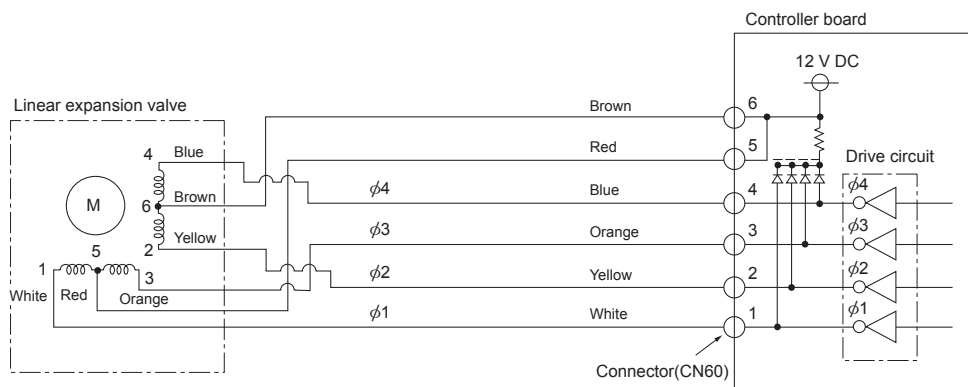

Note : Since the number of the connector at the controller board side and the relay connector are different, follow the color of the lead wire.

<Output pulse signal and the valve operation>

Output (Phase)	Output			
	1	2	3	4
φ1	ON	OFF	OFF	ON
φ2	ON	ON	OFF	OFF
φ3	OFF	ON	ON	OFF
φ4	OFF	OFF	ON	ON

The output pulse shifts in below order.
 Closing a valve : 1 → 2 → 3 → 4 → 1
 Opening a valve : 4 → 3 → 2 → 1 → 4

Note:

- When linear expansion valve operation stops, all output phases become OFF.
- At phase interruption or when phase does not shift in order, motor does not rotate smoothly and motor will lock and vibrate.
- When the power is turned on, 2200 pulse closing valve signal will be sent till it goes to point ① in order to define the valve position.
- When the valve moves smoothly, there is no sound or vibration occurring from the linear expansion valves, however, when the pulse number moves from ③ to ② or when the valve is locked, more sound can be heard than in a normal situation.
- Sound can be detected by placing the ear against the screw driver handle while putting the screw driver tip to the linear expansion valve.

② Linear expansion valve operation

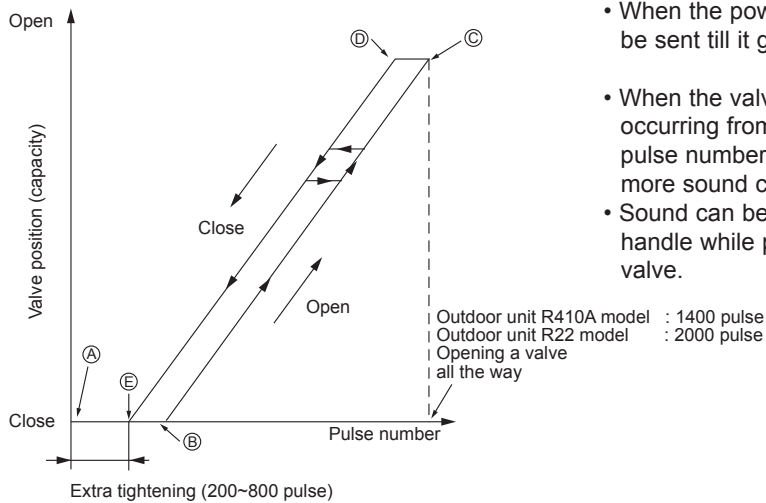

③ Troubleshooting

Symptom	Checkpoints	Countermeasures
Operation circuit failure of the micro processor	Disconnect the connector on the controller board, then connect LED for checking. 1kΩ LED	Exchange the indoor controller board at drive circuit failure.
Linear expansion valve mechanism is locked.	Motor will idle and make a ticking noise when the motor is operated while the linear expansion valve is locked. This ticking sound is the sign of the abnormality.	Exchange the linear expansion valve.
Short or breakage of the motor coil of the linear expansion valve	Measure the resistance between each coil (white-red, yellow-brown, orange-red, blue-brown) with a tester. It is normal if the resistance is in the range of 200Ω ±10%.	Exchange the linear expansion valve.
Valve does not close completely.	To check the linear expansion valve, operate the indoor unit in fan mode and at the same time operate other indoor units in cool mode, then check the pipe temperature <liquid pipe temperature> of the indoor unit by the outdoor multi controller board operation monitor. During fan operation, linear expansion valve is closed completely and if there is any leaking, detecting temperature of the thermistor will go lower. If the detected temperature is much lower than the temperature indicated in the remote controller, it means the valve is not closed all the way. Thermistor (Liquid pipe) Linear expansion valve	If large amount of refrigerant is leaked, exchange the linear expansion valve.
Wrong connection of the connector or contact failure	Check the color of lead wire and missing terminal of the connector.	Disconnect the connector at the controller board, then check the continuity.

9-1-3. DC Fan motor (fan motor/indoor controller board)

Check method of indoor fan motor (fan motor/indoor controller board)

① Notes

- High voltage is applied to the connector (CNMF) for the fan motor. Pay attention to the service.
- Do not pull out the connector (CNMF) for the motor with the power supply on.
(It causes trouble of the indoor controller board and fan motor)





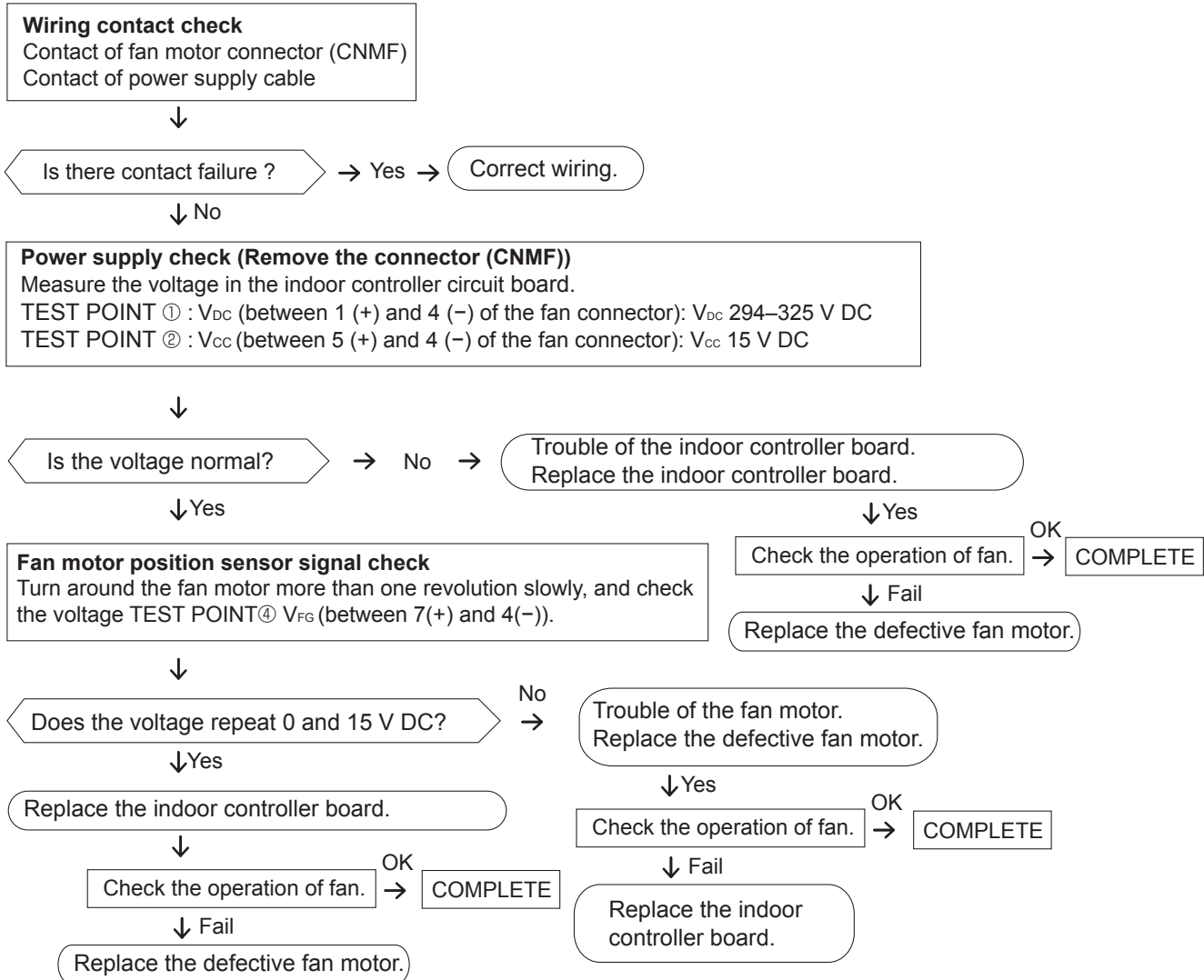





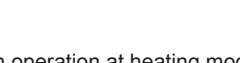







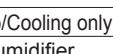
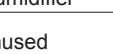
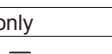
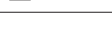
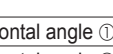
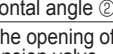
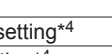
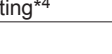







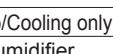
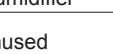
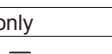
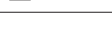
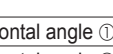
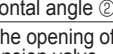
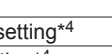
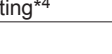

② Self check

Conditions : The indoor fan cannot rotate.

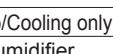
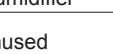
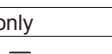
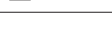
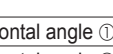
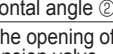
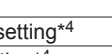
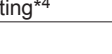

9-2. FUNCTION OF DIP SWITCH

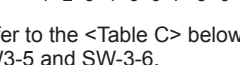
The black square (■) indicates a switch position.

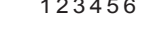
Switch	Pole	Function	Operation by switch		Effective timing	Remarks																				
			ON	OFF																						
SW1 Function Selection	1	Thermistor <Room temperature detection> position	Built-in remote controller	Indoor unit	Under suspension	<div style="border: 1px solid black; padding: 2px; display: inline-block;">Indoor controller board</div> <Initial setting> ON  OFF  1 2 3 4 5 6 7 8 9 0																				
	2	Filter clogging detection	Provided	Not provided																						
	3	Filter cleaning	2,500h	100h																						
	4	Fresh air intake	Effective	Not effective																						
	5	Switching remote indication	Thermo-ON signal display	Indicating fan operation ON/OFF																						
	6	Humidifier control	Always operated while the heat in ON*1	Operated depends on the condition*2																						
	7	Airflow set in case of heat thermo-OFF	Low*3	Extra low*3																						
	8		Setting airflow*3	Depends on SW1-7																						
	9	Auto restart function	Effective	Not effective																						
	0	Power ON/OFF by breaker	Effective	Not effective																						
SW2 Capacity code setting	1-6	<table border="1" style="width: 100%; text-align: center;"> <thead> <tr> <th>Capacity</th> <th>SW2</th> <th>Capacity</th> <th>SW2</th> </tr> </thead> <tbody> <tr> <td>P08</td> <td>ON  OFF  1 2 3 4 5 6</td> <td>P24</td> <td>ON  OFF  1 2 3 4 5 6</td> </tr> <tr> <td>P12</td> <td>ON  OFF  1 2 3 4 5 6</td> <td>P30</td> <td>ON  OFF  1 2 3 4 5 6</td> </tr> <tr> <td>P15</td> <td>ON  OFF  1 2 3 4 5 6</td> <td>P36</td> <td>ON  OFF  1 2 3 4 5 6</td> </tr> <tr> <td>P18</td> <td>ON  OFF  1 2 3 4 5 6</td> <td>P48</td> <td>ON  OFF  1 2 3 4 5 6</td> </tr> </tbody> </table>	Capacity	SW2	Capacity	SW2	P08	ON  OFF  1 2 3 4 5 6	P24	ON  OFF  1 2 3 4 5 6	P12	ON  OFF  1 2 3 4 5 6	P30	ON  OFF  1 2 3 4 5 6	P15	ON  OFF  1 2 3 4 5 6	P36	ON  OFF  1 2 3 4 5 6	P18	ON  OFF  1 2 3 4 5 6	P48	ON  OFF  1 2 3 4 5 6				<div style="border: 1px solid black; padding: 2px; display: inline-block;">Indoor controller board</div> <Initial setting> Set for each capacity.
		Capacity	SW2	Capacity	SW2																					
		P08	ON  OFF  1 2 3 4 5 6	P24	ON  OFF  1 2 3 4 5 6																					
		P12	ON  OFF  1 2 3 4 5 6	P30	ON  OFF  1 2 3 4 5 6																					
		P15	ON  OFF  1 2 3 4 5 6	P36	ON  OFF  1 2 3 4 5 6																					
P18	ON  OFF  1 2 3 4 5 6	P48	ON  OFF  1 2 3 4 5 6																							
SW3 Function setting	1	Heat pump/Cooling only	Cooling only	Heat pump	Under suspension	<div style="border: 1px solid black; padding: 2px; display: inline-block;">Indoor controller board</div> <Initial setting> Set for each capacity. ON  OFF  1 2 3 4 5 6 7 8 9 0																				
	2	Louver/Humidifier	—	—	Before power supply ON																					
	3	Unused	—		Under suspension																					
	4																									
	5	Vane horizontal angle ①	Second setting*4	First setting*4																						
	6	Vane horizontal angle ②	Third setting*4	Depends on SW3-5																						
	7	Changing the opening of linear expansion valve	Effective	Not effective																						
	8	Sensible temperature correction	Not effective	Effective																						
	9	Unused	—																							
	0																									
SW4 Model selection	1-6		ON  OFF  1 2 3 4 5 6		Before power supply ON	<div style="border: 1px solid black; padding: 2px; display: inline-block;">Indoor controller board</div> Service controller board only																				

<Table A>





SW1-7	SW1-8	
OFF	OFF	Extra low
ON	OFF	Low
OFF	ON	Setting airflow
ON	ON	stop

<Table C>

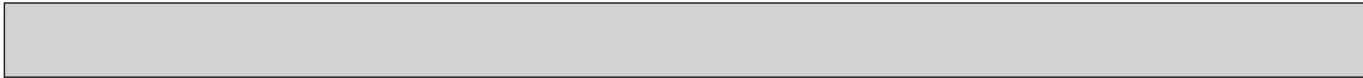
SW3-5	SW3-6	Vane setting	Initial setting	Setting	Vane position
OFF	OFF	Setting ①	●	Standard	Standard
ON	OFF	Setting ②		Less draft*5	Upward position than the standard
OFF	ON	Setting ③		Less smudging	Downward position than the standard
ON	ON	Unused		—	—

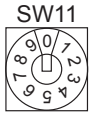
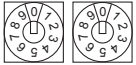
*5 Be careful of the smudge on ceiling.



Switch	Pole	Function	Operation by switch		Effective timing	Remarks
			ON	OFF		
SW11 1s digit address setting SW12 10s digit address setting	Rotary switch	  10 1	Address setting should be done when M-NET remote controller is being used.		Before power supply ON	<div style="border: 1px solid black; padding: 2px; display: inline-block;">Indoor controller board</div> <Initial setting> 
SW14 Connection No. setting	Rotary switch	 SW14	This is the switch to be used when the indoor unit is operated with R2 series outdoor unit as a set.			<div style="border: 1px solid black; padding: 2px; display: inline-block;">Indoor controller board</div> <Initial setting> 
SW21 Function Selection	1	Setting the ceiling height	Depending on the combination of SW21-1 and SW21-2.		Under suspension	<div style="border: 1px solid black; padding: 2px; display: inline-block;">Indoor controller board</div> <Initial setting> 
	2	Setting the ceiling height	Refer to the <Table E> below.			
	3	Setting the number of air outlet	Depending on the combination of SW21-3 and SW21-4.			
	4	Setting the number of air outlet	Refer to the <Table E> below.			
	5	Setting for optional parts	Option	Standard		
	6	Not used	Not used	Not used		

<Table E>

			PLFY-P08/12/15/18/24/30NEMU-E						PLFY-P36/48NEMU-E					
			Silent		Standard		High ceiling		Silent		Standard		High ceiling	
			SW21-1	SW21-2	SW21-1	SW21-2	SW21-1	SW21-2	SW21-1	SW21-2	SW21-1	SW21-2	SW21-1	SW21-2
			OFF	ON	OFF	OFF	ON	OFF	OFF	ON	OFF	OFF	ON	OFF
4 direction	SW21-3	OFF	8.2 ft [2.5 m]		8.9 ft [2.7 m]		11.5 ft [3.5 m]		8.9 ft [2.7 m]		10.5 ft [3.2 m]		14.8 ft [4.5 m]	
3 direction	SW21-4	ON	8.2 ft [2.5 m]		8.9 ft [2.7 m]		11.5 ft [3.5 m]		8.9 ft [2.7 m]		10.5 ft [3.2 m]		14.8 ft [4.5 m]	
	SW21-3	OFF	8.9 ft [2.7 m]		9.8 ft [3.0 m]		11.5 ft [3.5 m]		9.8 ft [3.0 m]		11.8 ft [3.6 m]		14.8 ft [4.5 m]	
2 direction	SW21-4	OFF	8.9 ft [2.7 m]		9.8 ft [3.0 m]		11.5 ft [3.5 m]		9.8 ft [3.0 m]		11.8 ft [3.6 m]		14.8 ft [4.5 m]	
	SW21-3	ON	9.8 ft [3.0 m]		10.8 ft [3.3 m]		11.5 ft [3.5 m]		10.8 ft [3.3 m]		13.1 ft [4.0 m]		14.8 ft [4.5 m]	

Note: The setting with indicates the initial setting; To change it to other than , switch setting is necessary.

Continue to the next page

The black square (■) indicates a switch position.

Switch	Pole	Operation by switch	Effective timing	Remarks																																					
SW22 Wireless remote controller pair No.	Jumper	<table border="1"> <thead> <tr> <th>Function</th> <th>ON</th> <th>OFF</th> </tr> </thead> <tbody> <tr> <td>1</td> <td>—</td> <td>—</td> </tr> <tr> <td>2</td> <td>—</td> <td>—</td> </tr> <tr> <td>3 Pair No. of wireless remote controller</td> <td colspan="2">Depends on the combination of SW22-3 and 22-4</td> </tr> <tr> <td>4 Pair No. of wireless remote controller</td> <td colspan="2"></td> </tr> </tbody> </table> <p>• To operate each indoor unit by each remote controller when installed 2 indoor units or more are near, Pair No. setting is necessary.</p> <p>① Pair No. setting is available with the 4 patterns (Setting patterns A to D).</p> <p>② Make setting for J41, J42 of indoor controller board and the Pair No. of wireless remote controller.</p> <p>• You may not set it when operating it by one remote controller.</p> <p>① Setting for indoor unit</p> <p>Cut jumper wire J41, J42 on the indoor controller board according to the table below.</p> <p>② Wireless remote controller pair No.:</p> <p>• Setting operation</p> <ol style="list-style-type: none"> 1. Press the SET button (using a pointed implement). Check that the remote controller's display has stopped before continuing. MODEL SELECT blinks, and the model No. (3 digits) appears (steadily-lit). 2. Press the MINUTE button twice. The pair No. appears flashing. 3. Press the TEMP ⓄⓄ buttons to select the pair No. to set. 4. Press the SET button (using a pointed implement). The set pair is displayed (steadily-lit) for 3 seconds, then disappears. <table border="1"> <thead> <tr> <th colspan="2">Indoor unit SW22</th> <th rowspan="2">Pair No. of wireless remote controller</th> <th rowspan="2"></th> </tr> <tr> <th>SW22-3</th> <th>SW22-4</th> </tr> </thead> <tbody> <tr> <td>ON</td> <td>ON</td> <td>0</td> <td>Initial setting</td> </tr> <tr> <td>OFF</td> <td>ON</td> <td>1</td> <td>—</td> </tr> <tr> <td>ON</td> <td>OFF</td> <td>2</td> <td>—</td> </tr> <tr> <td>OFF</td> <td>OFF</td> <td>3-9</td> <td>—</td> </tr> </tbody> </table>	Function	ON	OFF	1	—	—	2	—	—	3 Pair No. of wireless remote controller	Depends on the combination of SW22-3 and 22-4		4 Pair No. of wireless remote controller			Indoor unit SW22		Pair No. of wireless remote controller		SW22-3	SW22-4	ON	ON	0	Initial setting	OFF	ON	1	—	ON	OFF	2	—	OFF	OFF	3-9	—	Under operation or suspension	<p><Initial setting></p>
		Function	ON	OFF																																					
1	—	—																																							
2	—	—																																							
3 Pair No. of wireless remote controller	Depends on the combination of SW22-3 and 22-4																																								
4 Pair No. of wireless remote controller																																									
Indoor unit SW22		Pair No. of wireless remote controller																																							
SW22-3	SW22-4																																								
ON	ON	0	Initial setting																																						
OFF	ON	1	—																																						
ON	OFF	2	—																																						
OFF	OFF	3-9	—																																						
SWE Test run for Drain pump and Indoor fan motor	Connector	<p>Drain pump and indoor fan motor are activated simultaneously after the connector SWE is set to ON and turn on the power.</p> <p>The connector SWE is set to OFF after test run.</p>	Under operation	<p><Initial setting></p>																																					

9-3. TEST POINT DIAGRAM

9-3-1. Indoor controller board

PLFY-P08NEMU-E
PLFY-P24NEMU-E

PLFY-P12NEMU-E
PLFY-P30NEMU-E

PLFY-P15NEMU-E
PLFY-P36NEMU-E

PLFY-P18NEMU-E
PLFY-P48NEMU-E

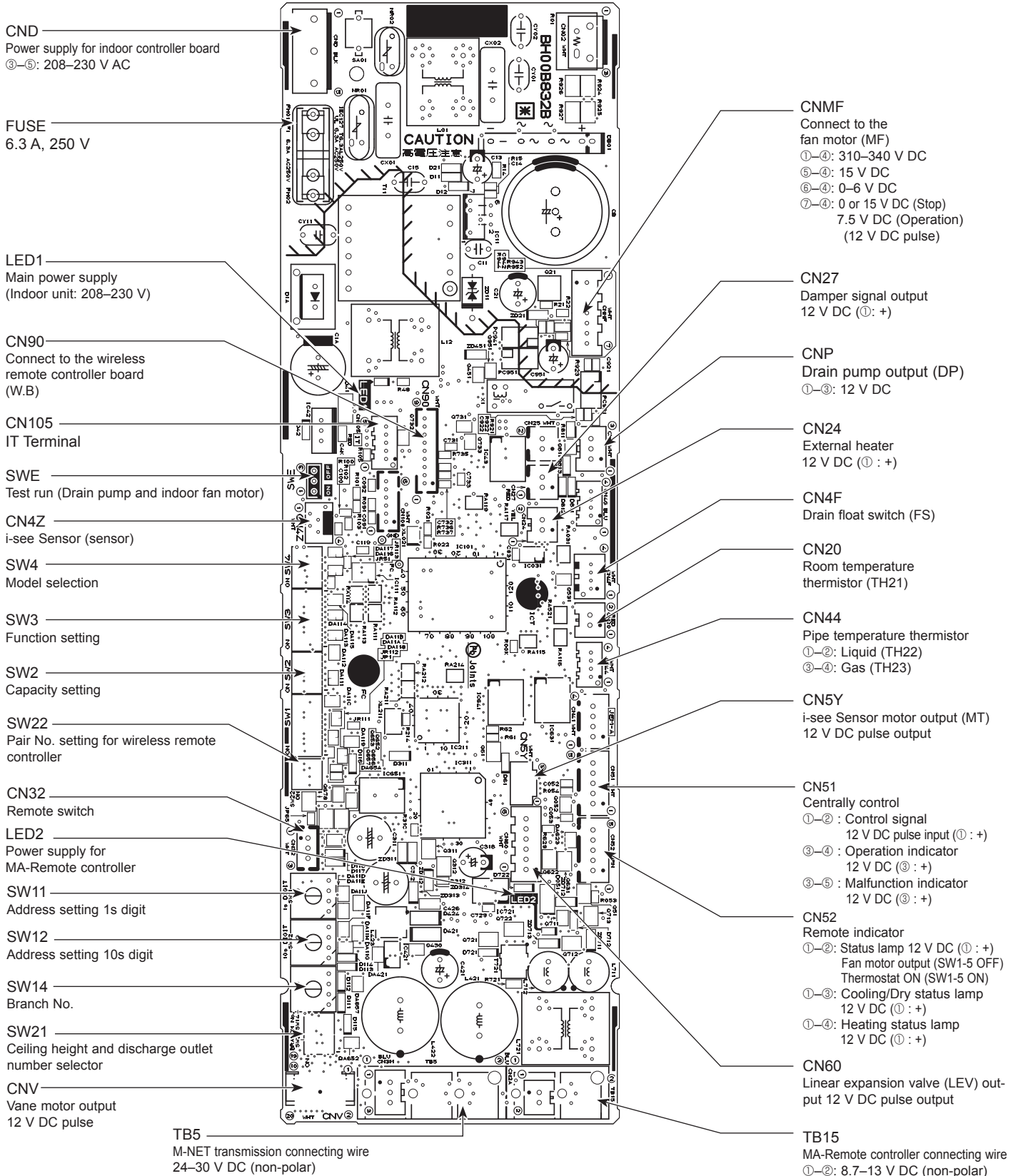

Note: The voltage range of 12 V DC in this page is between 11.5 to 13.7 V DC.

PLFY-P08NEMU-E
PLFY-P24NEMU-E

PLFY-P12NEMU-E
PLFY-P30NEMU-E

PLFY-P15NEMU-E
PLFY-P36NEMU-E

PLFY-P18NEMU-E
PLFY-P48NEMU-E

Be careful when removing heavy parts.

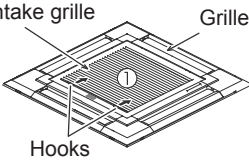
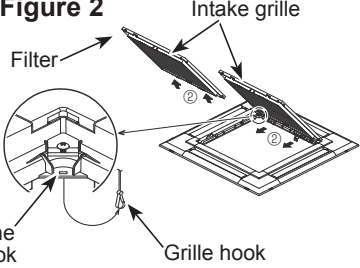
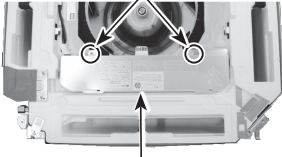
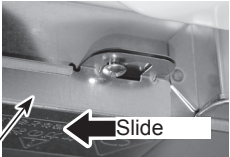
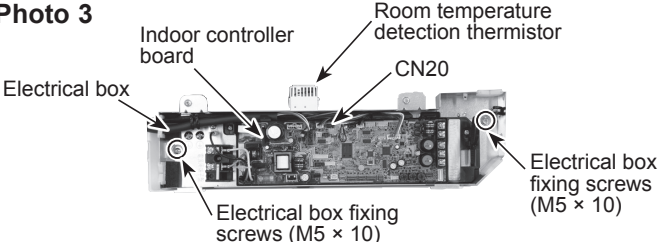
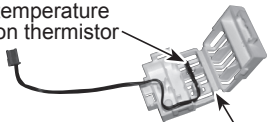
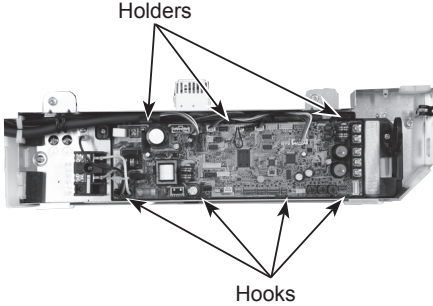
OPERATING PROCEDURE	PHOTOS/FIGURES
<p>1. Removing the intake grille and the filter</p> <ol style="list-style-type: none"> Slide the levers in the direction indicated by the arrows ① to open the intake grille. (See Figure 1.) Unlatch the hook that secures the grille, and pull out the filter to remove. With the intake grille in the "open" position, remove the hinge of the intake grille from the grille as indicated by the arrows ②. (See Figure 2.) 	<p>Figure 1</p>  <p>Figure 2</p> 
<p>2. Removing the electrical box cover</p> <ol style="list-style-type: none"> Remove the intake grille and the filter. (See Procedure 1.) Loosen the 2 electrical box cover fixing screws (M4 × 8) approximately 2 to 3 mm. (See Photo 1.) Slide the electrical box cover towards the arrow to remove. (See Photo 2.) 	<p>Photo 1</p>  <p>Photo 2</p> 
<p>3. Removing the room temperature detection thermistor (TH21)</p> <ol style="list-style-type: none"> Remove the intake grille and the filter. (See Procedure 1.) Remove the electrical box cover. (See Procedure 2.) Disconnect the connector CN20 (RD) from the indoor controller board. Remove the room temperature detection thermistor with its holder. (See Photo 4.) 	<p>Photo 3</p>  <p>Photo 4</p> 
<p>4. Removing the indoor controller board (I.B)</p> <ol style="list-style-type: none"> Remove the intake grille and the filter. (See Procedure 1.) Remove the electrical box cover. (See Procedure 2.) Disconnect the connectors: <ul style="list-style-type: none"> CNMF (WH) for fan motor CNV (WH) for vane motor CN5Y (WH) for i-see Sensor motor CN4Z (WH) for i-see Sensor (sensor) CN90 (WH) for wireless remote controller board CNP (WH) for drain pump CN4F (WH) for float switch CN44 (WH) for pipe temperature detection thermistor/liquid CND (BK) for indoor controller board power supply Disconnect the connectors for optional parts, if any. Disconnect the lead wire connected to the TB5 on the indoor controller board. TB5: M-NET transmission connecting wire For the unit controlled with the wireless remote controller, disconnect the lead wire connected to the TB15 on the indoor controller board. TB15: MA remote controller connecting wire Remove the indoor controller board by removing it from 3 holders and 4 hooks. (See Photo 5.) 	<p>Photo 5</p> 

OPERATING PROCEDURE

PHOTOS/FIGURES

5. Removing the electrical box

- (1) Remove the intake grille and the filter. (See Procedure 1.)
- (2) Remove the electrical box cover. (See Procedure 2.)
- (3) Disconnect the connectors. (Refer to procedure 4.)
- (4) Remove the 2 electrical box fixing screws (M5 × 10). (See Photo 3.)
 <Electrical parts contained in the electrical box>
 - Terminal block for power supply (TB2)
 - Indoor controller board
 - Room temperature detection thermistor (TH21)
- (5) Pull the electrical box to remove by removing it from 2 holders.

Photo 6

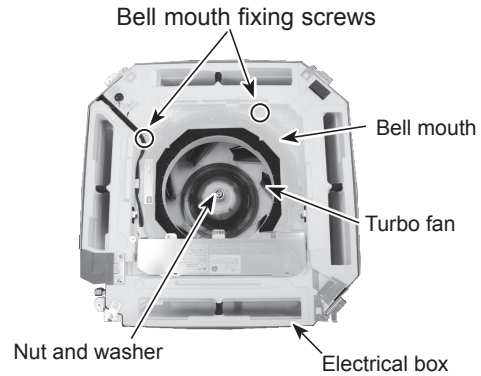

6. Removing the turbo fan

- (1) Remove the electrical box. (See Photo 3 and refer to 5.)
- (2) Remove the bell mouth (tapping screw 4×10: 2 screws). (See Photo 6.)

< With nut and square washer >

- (3) Remove the nut (M8 × 1) and a square washer. (See Photo 7 and 8.)
- (4) Remove the turbo fan.

< With nut and washer >

- (3) Remove the nut (M8 × 1) and a washer. (See Photo 7 and 8.)
- (4) Remove the turbo fan.

Note 1: When assembling the turbo fan, attach it so that its tabs fit the holes of washer.

Note 2: Nut tightening torque: 4.5 ± 0.5 Nm.

Photo 7

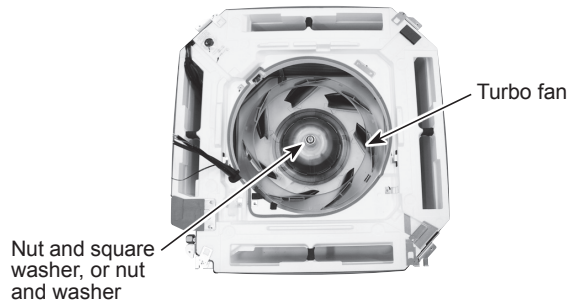

Turbo fan

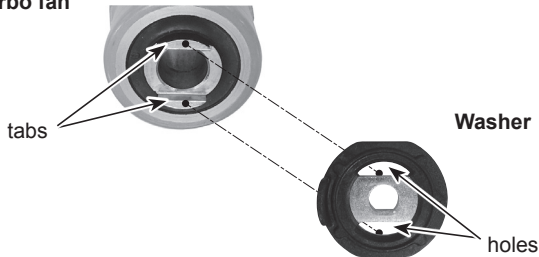

< Nut and square washer >



< Nut and washer >



Photo 8



Turn this way to tighten. Turn this way to loosen.
 (The same directions as the fan rotation.)

Photo 9



OPERATING PROCEDURE

7. Removing the turbo fan motor

- (1) Remove the intake grille and the filter. (See Procedure 1.)
- (2) Remove the electrical box cover. (See Procedure 2.)
- (3) Disconnect the connectors. (Refer to procedure 4.)
- (4) Remove the electrical box. (See Procedure 5.)
- (5) Remove the turbo fan. (See Procedure 6.)
- (6) Remove the 2 lead wire cover fixing screws (tapping screw: 4 × 10) to remove the lead wire cover. (See Photo 10.)
- (7) Loosen the 2 clamps.
- (8) Remove the 3 nuts and washers.
- (9) Remove the turbo fan from the motor shaft.
- (10) Remove the 3 rubber mounts.

Figure 3: Partial cross section

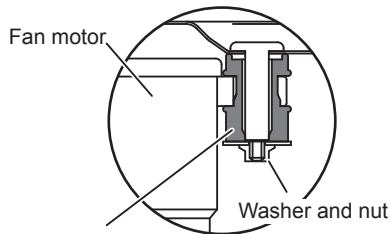

Note: When re-attaching the motor mount, make sure that the thicker end faces the motor shaft.

PHOTOS/FIGURES

Photo 10

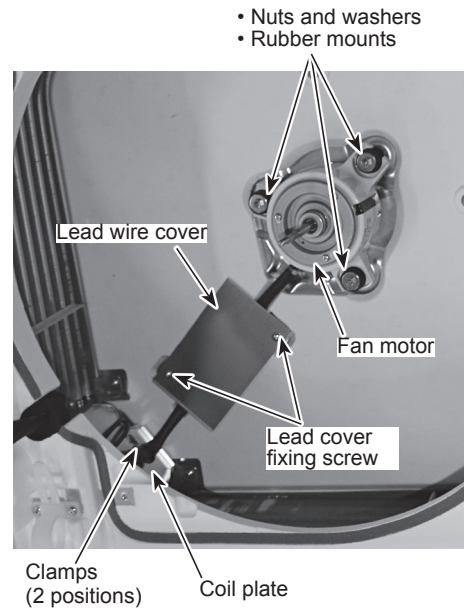

8. Removing the grille

- (1) Remove the intake grille and the filter. (See Procedure 1.)
- (2) Remove the electrical box cover. (See Procedure 2.)
- (3) Disconnect the connector CNV (WH).
- (4) Loosen the 4 corner panel fixing screw (tapping: 4 × 16). (see Figure 4.)
- (5) Slide the corner panel to the direction of the arrow ①, and remove the corner panel.
- (6) Remove the 4 installation screws (M5 × 28). (See Photo 11.)
- (7) Release the 2 temporary hanging hooks to remove the panel. (See Photo 12.)

Figure 4

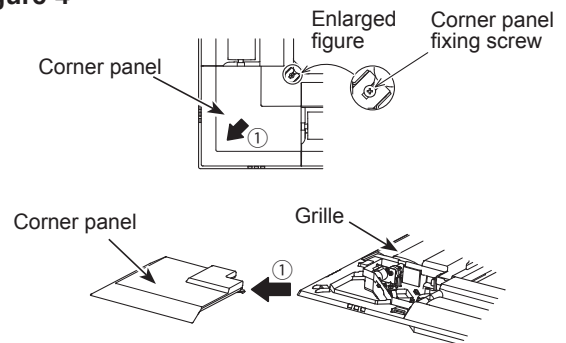

Photo 11

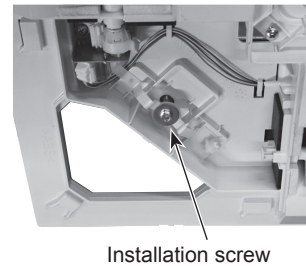
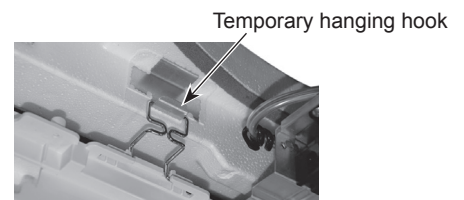
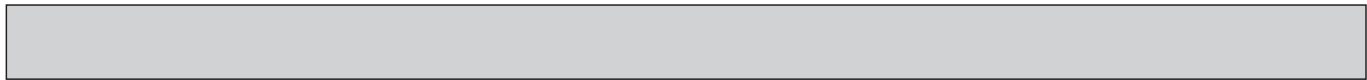

Photo 12





OPERATING PROCEDURE

PHOTOS/FIGURES

- 9. Removing the drain pan**
- (1) Remove the intake grille and the filter. (See Procedure 1.)
 - (2) Remove the electrical box cover. (See Procedure 2.)
 - (3) Disconnect the connectors. (Refer to Procedure 4.)
 - (4) Remove the grille. (See Procedure 8.)
 - (5) Remove the electrical box. (See Procedure 5.)
 - (6) Remove the 2 bell mouth fixing screws (tapping screw: 4 × 10) to remove the bell mouth. (See Photo 6.)
 - (7) Remove the 4 drain pan fixing screws (M5 × 10) and pull out the drain pan.

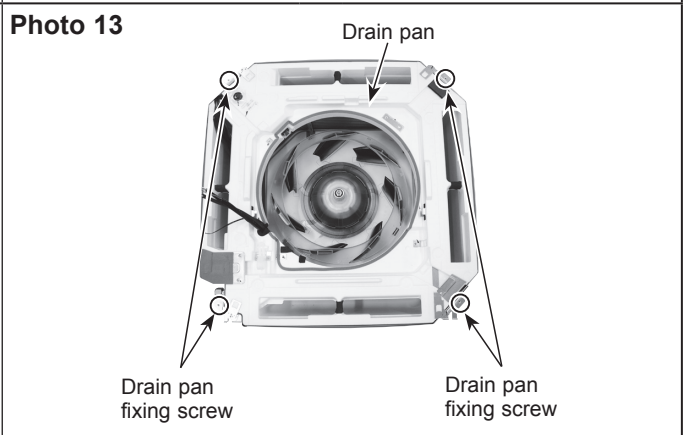

- 10. Removing the pipe temperature detection thermistor/liquid (TH22) and pipe temperature detection thermistor/gas (TH23)**
- (1) Remove the intake grille and the filter. (See Procedure 1.)
 - (2) Remove the electrical box cover. (See Procedure 2.)
 - (3) Disconnect the connectors. (Refer to Procedure 4.)
 - (4) Remove the grille. (See Procedure 8.)
 - (5) Remove the electrical box. (See Procedure 5.)
 - (6) Remove the 2 bell mouth fixing screws (tapping screw: 4 × 10) to remove the bell mouth. (See Photo 6.)
 - (7) Remove the drain pan. (See Procedure 9.)
 - (8) Remove the thermistors which are inserted into the holders installed to the thin copper pipe.

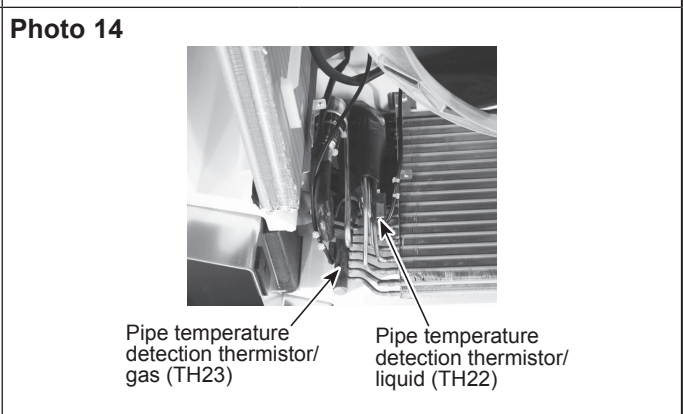

- 11. Removing the drain pump (DP) and float switch (FS)**
- (1) Remove the intake grille and the filter. (See Procedure 1.)
 - (2) Remove the electrical box cover. (See Procedure 2.)
 - (3) Disconnect the connectors. (Refer to Procedure 4.)
 - (4) Remove the grille. (See Procedure 8.)
 - (5) Remove the electrical box. (See Procedure 5.)
 - (6) Remove the 2 bell mouth fixing screws (tapping screw: 4 × 10) to remove the bell mouth. (See Photo 6.)
 - (7) Remove the drain pan. (See Procedure 9.)

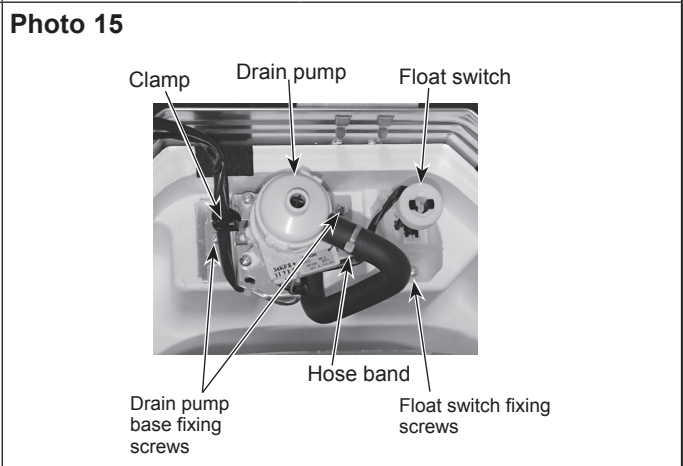

- Drain pump (DP)**
- (8) Cut the hose band and remove the hose. (See Photo 15.)
 - (9) Loosen the clamp for the drain pump. (See Photo 15.)
 - (10) Remove the 2 drain pump base fixing screws (tapping screw: 4 × 10), and loosen the 2 hooks to remove the drain pump assembly.
- Float switch (FS)**
- (8) Loosen the clamp for the drain pump. (See Photo 15.)
 - (9) Remove the float switch fixing screw (tapping screw: 4 × 10), and loosen the hook to remove the float switch. (See Photo 15,16.)

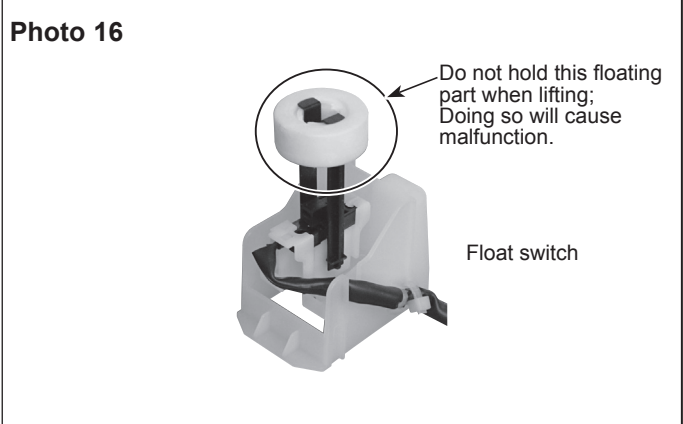

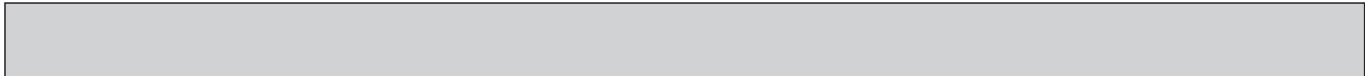

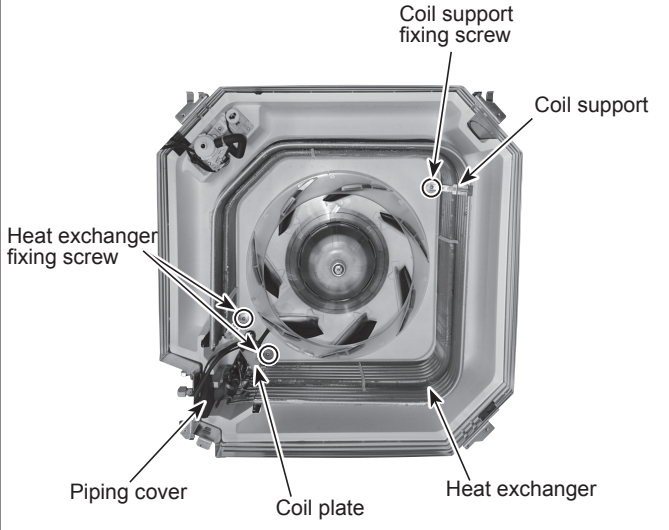
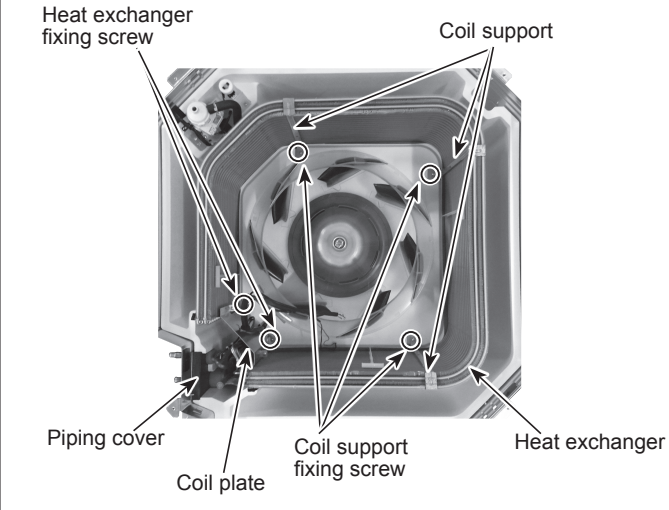
OPERATING PROCEDURE	PHOTOS/FIGURES
<p>12. Removing the heat exchanger</p> <ol style="list-style-type: none">(1) Remove the intake grille and the filter. (See Procedure 1.)(2) Remove the electrical box cover. (See Procedure 2.)(3) Disconnect the connectors. (Refer to Procedure 4.)(4) Remove the grille. (See Procedure 8.)(5) Remove the electrical box. (See Procedure 5.)(6) Remove the 2 bell mouth fixing screws (tapping screw: 4 × 10) to remove the bell mouth. (See Photo 6.)(7) Remove the drain pan. (See Procedure 9.)(8) Remove the 3 piping cover fixing screws (tapping screw: 4 × 10) to remove the piping cover. (See Photo 17.)(9) Remove the 2 coil plate fixing screws (tapping screw: 4 × 10) to remove the coil plate. (See Photo 17.)(10) Remove the heat exchanger fixing screws (tapping screw: 4 × 10). (See Photo 17.)(11) Remove the coil support fixing screws (tapping screw: 4 × 10) to remove the coil support(*1). (See Photo 17.)<ul style="list-style-type: none">• PLFY-P08/12/15/18/24/30NEMU-E: 1 coil support• PLFY-P36/48NEMU-E: 3 coil supports(12) Remove the heat exchanger. (See Photo 17.)	<p>Photo 17</p> <p>■ PLFY-P08/12/15/18/24/30NEMU-E</p>  <p>■ PLFY-P36/48NEMU-E</p> 

CITY MULTI

MITSUBISHI ELECTRIC CORPORATION

HEAD OFFICE : TOKYO BUILDING, 2-7-3, MARUNOUCHI, CHIYODA-KU TOKYO 100-8310, JAPAN

©Copyright 2016 MITSUBISHI ELECTRIC CORPORATION
Issued: Mar.2018 No. OCH611 REVISED EDITION-D
Issued: Aug.2017 No. OCH611 REVISED EDITION-C
Issued: Jun.2017 No. OCH611 REVISED EDITION-B
Issued: Jun.2016 No. OCH611 REVISED EDITION-A
Published: Mar. 2016 No. OCH611
Made in Japan

Specifications are subject to change without notice.