



Changes for the Better

SPLIT-TYPE, HEAT PUMP AIR CONDITIONERS

No. OC291

CITY MULTI Indoor Unit TECHNICAL & SERVICE MANUAL

CITY MULTI Series Wall Mounted Type

- [Models]
- PKFY-08NAMU-A**
 - PKFY-12NGMU-A**
 - PKFY-20NFMU-A**
 - PKFY-32NFMU-A**

CITY MULTI Series Ceiling Cassettes Type

- [Models]
- PLFY-12NAMU-A**
 - PLFY-20NAMU-A**
 - PLFY-24NAMU-A**
 - PLFY-32NAMU-A**
 - PLFY-40NAMU-A**

CONTENTS

- 1. PKFY-•MU-A TypeOC292-1
- 2. PLFY-•NAMU-A TypeOC290-1

• Connected outdoor unit is
PURY-80TMU or **PURY-100TMU**.



CITY MULTI

**PKFY-08NAMU-A
PKFY-12NGMU-A
PKFY-20NFMU-A
PKFY-32NFMU-A**

CONTENTS

1. DIFFERENCES	OC292- 3
2. FEATURES	OC292- 4
3. PART NAMES AND FUNCTIONS	OC292- 7
4. SPECIFICATIONS	OC292-10
5. OUTLINES AND DIMENSIONS.....	OC292-17
6. WIRING DIAGRAM.....	OC292-21
7. REFRIGERANT SYSTEM DIAGRAM	OC292-24
8. MICROPROCESSOR CONTROL	OC292-25
9. TROUBLESHOOTING.....	OC292-33
10. DISASSEMBLY PROCEDURE	OC292-42
11. PARTS LIST.....	OC292-51

1

DIFFERENCES

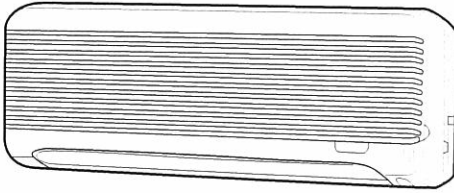

PKFY-08NAMU-A
Indoor Unit

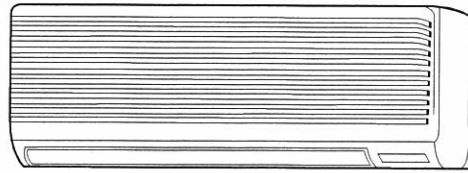

PKFY-12NGMU-A
Indoor Unit

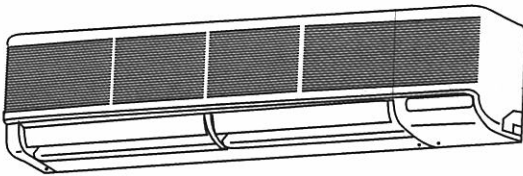

PKFY-20NFMU-A
Indoor Unit

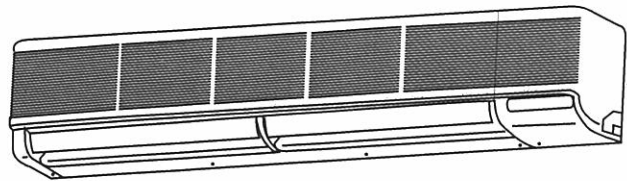

PKFY-32NFMU-A
Indoor Unit

Differences among the models of PKFY series.

Item	Model		PKFY-												
			08NAMU-A			12NGMU-A			20NFMU-A			32NFMU-A			
Fan	—		Lineflow fan × 1			Lineflow fan × 1			Lineflow fan × 2						
Fan speed	—		4 speeds type			4 speeds type			2 speeds type			2 speeds type			
Air flow	High	CFM	D R Y	210	190	D R Y	410	370	D R Y	640	570	D R Y	990	890	
	Medium 1	CFM		200	180		370	330		—	—		—	—	
	Medium 2	CFM		180	170		340	300		—	—		—	—	
	Low	CFM		170	160		280	250		490	440		780	700	
Noise level	High	dB	36			42			45			49			
	Medium 1	dB	35			40			—			—			
	Medium 2	dB	33			36			—			—			
	Low	dB	32			32			39			46			
Out dimension	Height	in.	11-5/8			13-3/8			13-3/8						
	Width	in.	32-3/32			39			55-1/8			66-1/8			
	Depth	in.	6-7/32			9-1/4			9-1/4						
Controller board	SW2	1	—	OFF			OFF			OFF			OFF		
		2	—	OFF			ON			ON			OFF		
		3	—	ON			ON			OFF			OFF		
		4	—	OFF			OFF			ON			OFF		
		5	—	—			OFF			OFF			ON		
		6	—	—			OFF			OFF			OFF		
Pipe dimension	Gas side	in.	1/2"			1/2"			5/8"						
	Liquid side	in.	1/4"			1/4"			3/8"						
	Drain(unit side)	in.	O.D. 5/8"			O.D. 13/16"			O.D. 13/16"						

2

FEATURES

PKFY-08NAMU-A

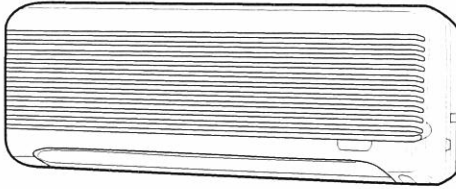

Indoor Unit

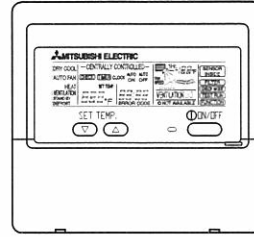

Microprocessor
Remote controller

Model

PKFY-08NAMU-A

Cooling capacity / Heating capacity

8,000/9,000 Btu/h

2-1. New Compact Design

- Compact 11-5/8 inch (29.5cm) high body fits snugly in even limited spaces.
- Light weight 19lbs (8.5kg) unit easy to transport and install.

2-2. Auto-flap shutter Enhances good Looks

With a simple flick of the OFF switch the air outlet can be closed off with a shutter. The shutter also functions as a flap during operation to adjust the air flow angle, with "Auto Angle" securing a comfortable air flow.

2-3. Front power supply box for easier wiring even after installation

The front power supply box allows electrical wiring work to be done after the indoor unit has been installed. For easier installation, all the screws required for securing the indoor unit to the wall are accessible from the front of the unit.

2-4. 4-way piping provides more flexibility in selecting installation sites

All piping including drainage can be connected from the rear, right, base, and left of the unit, providing much greater flexibility out piping and selecting installation site.

PKFY-12NGMU-A

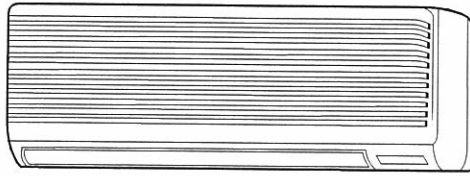

Indoor Unit

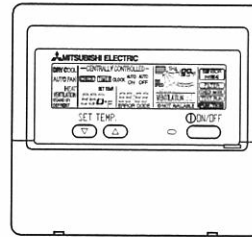

Microprocessor
Remote controller

Model

PKFY-12NGMU-A

Cooling capacity / Heating capacity

12,000 / 12,500 Btu/h

2-1. New Compact Design

Units have now been downsized to require minimal wall space.

A 20% reduction in width 38-31/32 inch (990mm) compared to previous models means that installation is possible in very narrow spaces.

2-2. Auto-flap shutter Enhances Good Looks

With a simple flick of the OFF switch the air outlet can be closed off with a with a shutter. The shutter also functions as a flap during operation to adjust the air flow angle, with "Auto Angle" securing a comfortable air flow.

2-3. The Intake Grille Filter Can be Completely Removed Allowing Easy Cleaning (Can be washed in water)

- Front grille opens out

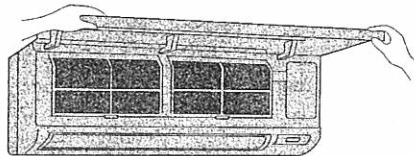

2-4. Quiet Operation

•Airflow passage configuration that assures quiet operation

- ① The unit incorporates a randompitch cycling fan. By changing fan intervals, quiet operation is achieved without reduction in airflow. Optimal design of the airflow passage gives a shortened fan diameter and allows a highly compact installation.
- ② Thanks to a highly practical casing configuration, airflow generated by the fan is distributed uniformly.
- ③ Due to careful positioning of the vertical vane axis, air is blown evenly from the outlet. This prevents mixing with secondary air and also suppresses condensation.

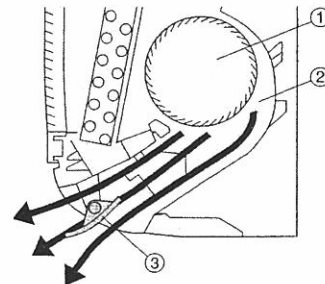

2-5. 4-way Piping Provides more Flexibility in Selecting Installation Sites

PKFY-20NFMU-A
PKFY-32NFMU-A

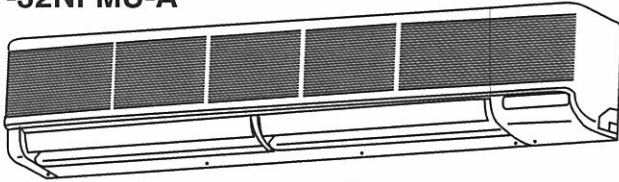

Indoor Unit

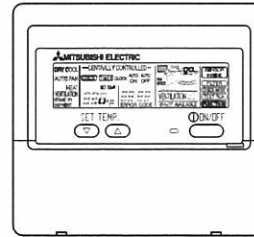

Microprocessor
Remote controller

Models

PKFY-20NFMU-A
PKFY-32NFMU-A

Cooling capacity / Heating capacity

20,000 / 22,500 Btu/h
32,000 / 35,500 Btu/h

2-1. COMPACT DESIGN

The PKFY series models have been downsized and now require such minimal wall space that they can even be installed above windows. For the PKFY series models, 14-9/16 inch (37 cm) of wall space between the ceiling and the window allows "above window" installation.

2-2. A FURTHER REFINEMENT OF COMFORT WITH NISE SUPPRESSION

Remarkably low-noise operation has been achieved through the development of a "near -silent" fan and the design which minimises air flow resistance.

2-3. AUTO FLAP SHUTTER

With a simple flick of the OFF switch the air outlet can be closed off with a shutter. The shutter also functions as a flap during operation to adjust the air flow angle, with "Auto Angle" securing a comfortable air flow.

2-4. INSTALLATION : FAST AND ENDLESSLY ADAPTABLE

(1) Multi-directional piping

Multi directional drain and refrigerant piping radically improves flexibility in selecting installation layouts. PKFY- • NFMU-A models boast refrigerant piping in 4 directions and drain piping 2 directions.

(2) Back plate installation guide

The back plate installation guide gives clear instructions on installation positions. The enlarged back plate secures the unit firmly to the wall, while the support piece which lifts the unit makes left side piping work much easier.

(3) Easily removable filter

The presence of thumbscrews on the filters means that the filters can be quickly and smoothly removed.

3

PART NAMES AND FUNCTIONS

● Indoor Unit
[PKFY-08NAMU-A]

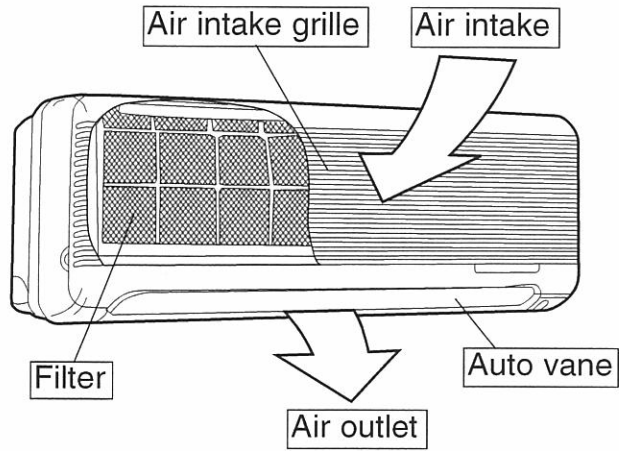

[PKFY-12NGMU-A]

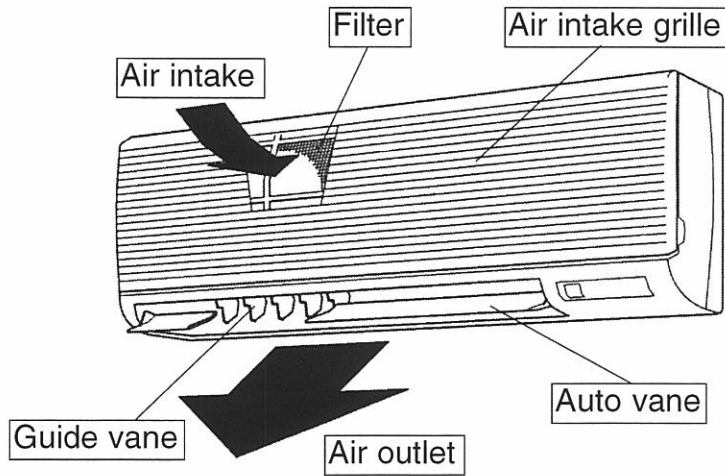

[PKFY-20NFMU-A]
[PKFY-32NFMU-A]

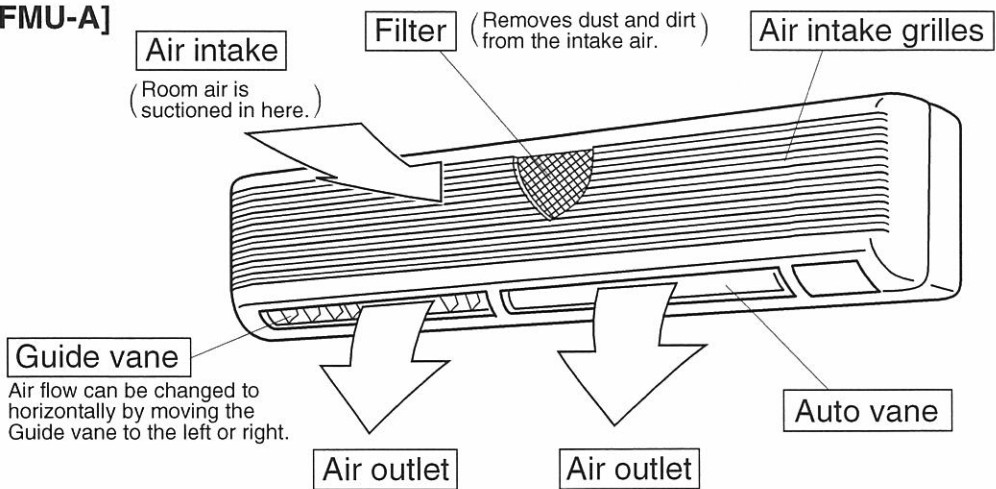

● **Remote controller**

- Once the operation of the unit is set, subsequent operations can only be performed by pressing the ON/OFF button repeatedly.

● **Operation buttons**

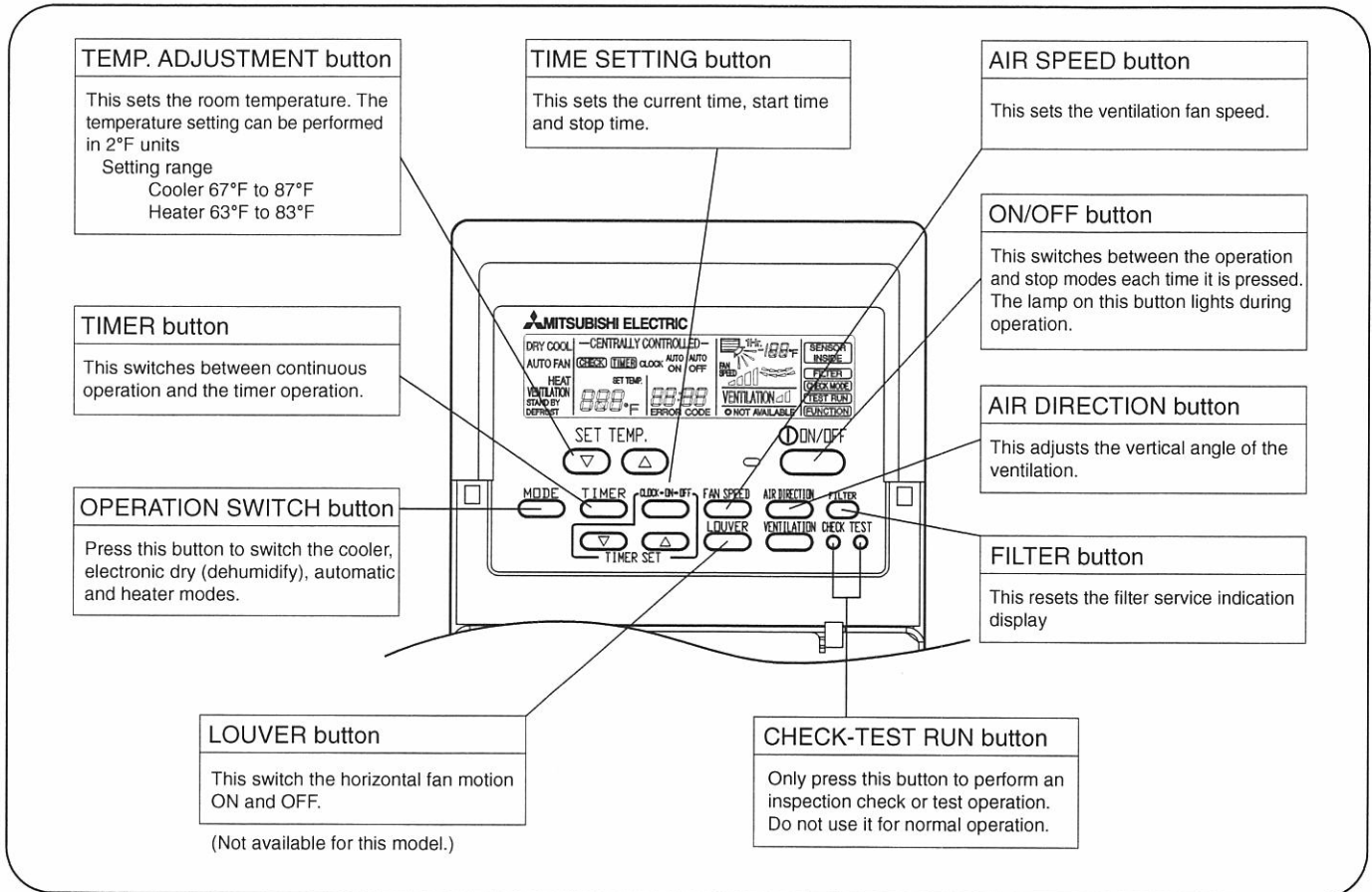

● Display

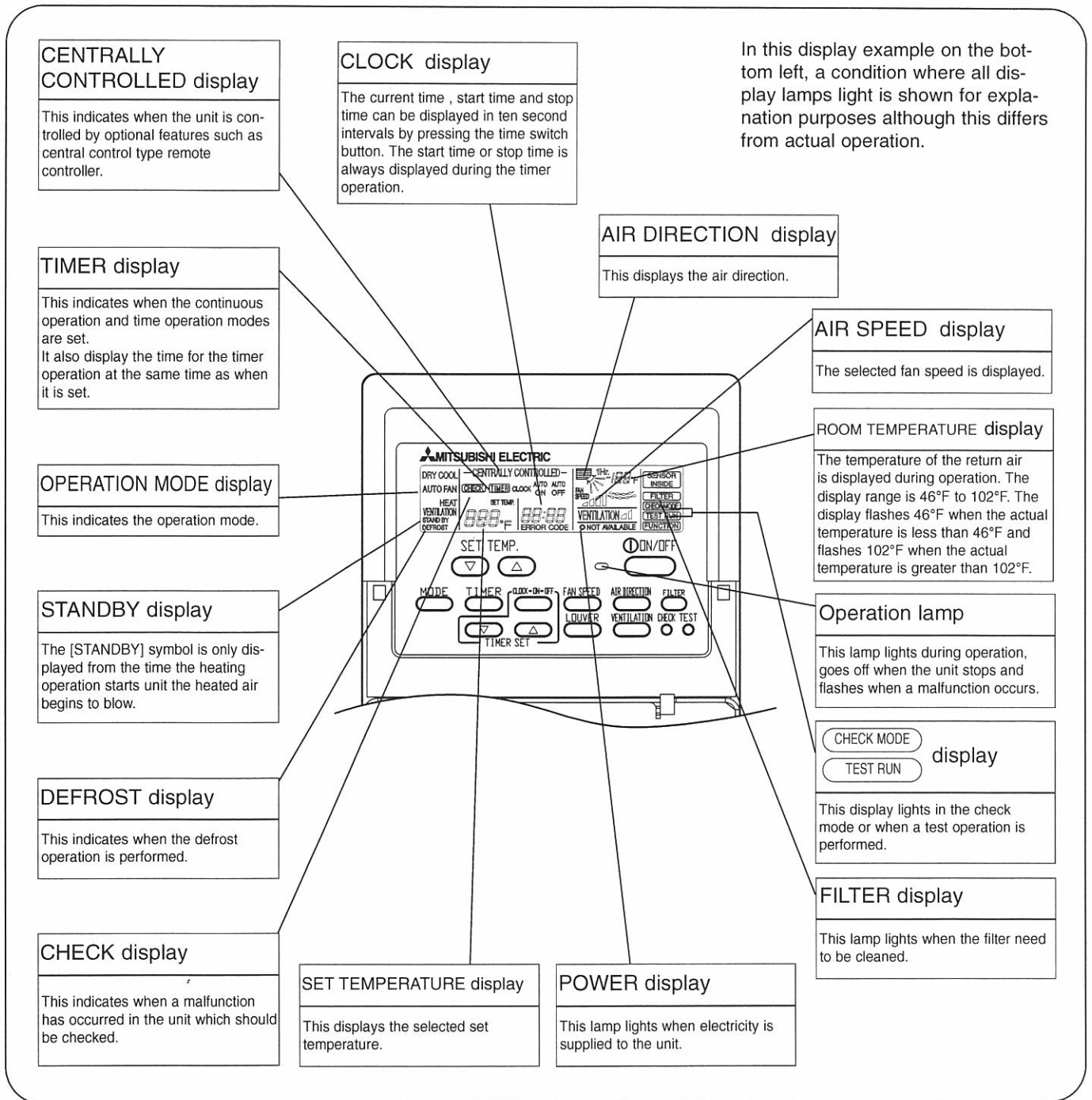

Caution

- Only the Power display lights when the unit is stopped and power supplied to the unit.
- When the central control remote control unit, which is sold separately, is used the ON-OFF button, operation switch button and TEMP. adjustment button do not operate.
- "NOT AVAILABLE" is displayed when the Air speed button is pressed. This indicates that this room unit is not equipped with the fan direction adjustment function and the louver function.
- When power is turned ON for the first time, it is normal that "H0" is displayed on the room temperature indication (For max. 2minutes). Please wait until this "H0" indication disappears then start the operation.

4

SPECIFICATIONS

4-1. Specifications

PKFY-08NAMU-A

Item		Unit	PKFY-08NAMU-A	
Power		ϕ ,V,Hz	Single phase, 208/230V, 60Hz	
Cooling capacity		Btu/h	8,000	
Heating capacity		Btu/h	9,000	
Electric characteristic	Power Supply	Cooling	kW	0.03
		Heating	kW	0.03
	Starting Current	Cooling	A	0.15
		Heating	A	0.15
Exterior <munsell symbol>		—	Plastic munsell : <2.60Y 8.66/0.69>	
Out dimensions	Height	in.	11-5/8	
	Width	in.	32-3/32	
	Depth	in.	6-7/32	
Heat exchanger		—	Cross fin	
Fan	Fan × No.		—	Lineflow fan × 1
	Air flow ※ 2	DRY	CFM	170-180-200-210
		WET	CFM	160-170-180-190
	External static pressure		Pa	0
	Fan motor output		kW	0.008
Insulator		—	Polyethylene sheet	
Air filter		—	PP honey comb	
Pipe dimensions	Gas side	in.	1/2"	
	Liquid side	in.	1/4"	
Unit drain pipe size		in.	PVC pipe with O.D. 5/8"	
Noise level ※ 2		dB	32-33-35-36	
Product weight		lbs	19	

Note 1. Rating conditions

Cooling : Indoor	D.B. 80°F	W.B. 67°F
Outdoor	D.B. 95°F	W.B. 75°F
Heating : Indoor	D.B. 70°F	
Outdoor	D.B. 47°F	W.B. 43°F

※ 2. Air flow and the noise level are indicated as Low - Medium2 - Medium1 - High.

• Connected outdoor unit is PURY-80TMU or PURY-100TMU.

PKFY-12NGMU-A

Item		Unit	PKFY-12NGMU-A	
Power		ϕ, V, Hz	Single phase, 208/230V, 60Hz	
Cooling capacity		Btu/h	12,000	
Heating capacity		Btu/h	12,500	
Electric characteristic	Input	Cooling	kW	0.07
		Heating	kW	0.07
	Current	Cooling	A	0.34
		Heating	A	0.34
Exterior <munsell symbol>		—	Plastic , white : <0.70Y 8.59/0.97>	
Out dimensions		Height	in.	13-3/8
		Width	in.	39
		Depth	in.	9-1/4
Heat exchanger		—	Cross fin (Aluminum plate fin and copper tube)	
Fan	Fan × No.		—	Lineflow fan × 1
	Air flow ※ 2	DRY	CFM	280-340-370-410
		WET	CFM	250-300-330-370
	External static pressure		Pa	0
	Fan motor output		kW	0.03
Insulator		—	Polyethylene sheet	
Air filter		—	PP honey comb	
Pipe dimensions		Gas side	in.	1/2"
		Liquid side	in.	1/4"
Unit drain pipe size		in.	PVC pipe with O.D. 13/16"	
Noise level ※ 2		dB	32-36-40-42	
Product weight		lbs	35	

Note 1. Rating conditions

Cooling : Indoor : D.B. 80°F W.B. 67°F
 outdoor : D.B. 95°F W.B. 75°F
 Heating : Indoor : D.B. 70°F
 outdoor : D.B. 47°F W.B. 43°F

※ 2. Air flow and the noise level are indicated as Low - Medium2 - Medium1 - High.

• Connected outdoor unit is PURY-80TMU or PURY-100TMU.

PKFY-20NFMU-A
PKFY-30NFMU-A

Item		Unit	PKFY-20NFMU-A	PKFY-32NFMU-A	
Power source		ϕ, V, Hz	Single phase, 208V-220V, 60Hz		
Cooling capacity		Btu/h	20,000	32,000	
Heating capacity		Btu/h	22,500	35,500	
Electric characteristic	Input	Cooling	kW	0.09	0.12
		Heating	kW	0.09	0.12
	Current	Cooling	A	0.44	0.58
		Heating	A	0.44	0.58
Exterior <munsell symbol>		—	Plastic , white : <3.4Y 7.7/0.8>		
Dimensions	Height	in.	13-3/8		
	Width	in.	55-1/8	66-1/8	
	Depth	in.	9-1/4		
Heat exchanger		—	Cross fin(Aluminum plate fin and copper tube)		
Fan	Type × No.		—	Lineflow fan × 2	
	Air flow Low - High	DRY	CFM	490 - 640	780 - 990
		WET	CFM	440 - 570	700 - 890
	External static pressure		Pa	0	
	Fan motor output		kW	0.045	0.070
Insulator		—	Polyethylene sheet		
Air filter		—	PP Honeycomb fabric		
Pipe dimensions	Gas side	in.	5/8"		
	Liquid side	in.	3/8"		
Unit drain pipe dimension		in.	PVC pipe with O.D. 13/16"		
Noise level Low - High		dB	39 - 45	46 - 49	
Product weight		lbs	53	62	

Note 1. Rating conditions
Cooling : Indoor : D.B. 80°F W.B. 67°F
 outdoor : D.B. 95°F W.B. 75°F
Heating : Indoor : D.B. 70°F
 outdoor : D.B. 47°F W.B. 43°F

• Connected outdoor unit is PURY-80TMU or PURY-100TMU.

4-2. Electrical parts specifications

PKFY-08NAMU-A

Model Parts name	Symbol	PKFY-08NAMU-A
Room temperature thermistor	TH21	Resistance 30°F/15.8kΩ, 50°F/9.6kΩ, 70°F/6.0kΩ, 80°F/4.8kΩ, 90°F/3.9kΩ, 100°F/3.2kΩ
Liquid pipe thermistor	TH22	Resistance 30°F/15.8kΩ, 50°F/9.6kΩ, 70°F/6.0kΩ, 80°F/4.8kΩ, 90°F/3.9kΩ, 100°F/3.2kΩ
Gas pipe thermistor	TH23	Resistance 30°F/15.8kΩ, 50°F/9.6kΩ, 70°F/6.0kΩ, 80°F/4.8kΩ, 90°F/3.9kΩ, 100°F/3.2kΩ
Fuse (Indoor power board)	FUSE	250V 6A
Fan motor (with thermal fuse)	MF	4-Pole Output 8W / PS4N8
Fan motor capacitor	C	1.2μF × 440V
Vane motor (with limit switch)	MV	MSFBC20A03 DC12V
Linear expansion valve	LEV	DC12V Stepping motor drive Port φ3.2 (0~2000pulse) EDM-402ME
Power supply terminal block	TB2	(L1, L2,GR) 250V 20A
Transmission terminal block	TB5	(M1, M2) 250V 10A

PKFY-12NGMU-A

Parts name	Model	Symbol	PKFY-12NGMU-A
Room temperature thermistor		TH21	Resistance 30°F/15.8kΩ, 50°F/9.6kΩ, 70°F/6.0kΩ, 80°F/4.8kΩ, 90°F/3.9kΩ, 100°F/3.2kΩ
Liquid pipe temperature thermistor		TH22	Resistance 30°F/15.8kΩ, 50°F/9.6kΩ, 70°F/6.0kΩ, 80°F/4.8kΩ, 90°F/3.9kΩ, 100°F/3.2kΩ
Gas pipe temperature thermistor		TH23	Resistance 30°F/15.8kΩ, 50°F/9.6kΩ, 70°F/6.0kΩ, 80°F/4.8kΩ, 90°F/3.9kΩ, 100°F/3.2kΩ
Fuse (Indoor controller board)		FUSE	250V 6A
Fan motor (with inner-thermostat)		MF	PM4N30-KA 208V/230V 60Hz 4 pole Output 30W
			Inner-thermostat
Fan motor capacitor		C	2.0μF 440V
Vane motor		MV	MP 35 EA DC12V
Linear expansion valve		LEV	DC12V Stepping motor drive Port dimension φ3.2 (0 ~ 2000pulse)
Power supply terminal block		TB2	(L1, L2, GR) 330V 30A
Transmission terminal block		TB5	(M1, M2, S) 250V 20A
MA remote controller terminal block		TB15	(1,2) 250V 10A

PKFY-20NFMU-A
PKFY-30NFMU-A

Parts name	Model	Symbol	PKFY-20NFMU-A	PKFY-32NFMU-A
Room temperature thermistor	TH21		Resistance 30°F/15.8kΩ, 50°F/9.6kΩ, 70°F/6.0kΩ, 80°F/4.8kΩ, 90°F/3.9kΩ, 100°F/3.2kΩ	
Liquid pipe temperature thermistor	TH22		Resistance 30°F/15.8kΩ, 50°F/9.6kΩ, 70°F/6.0kΩ, 80°F/4.8kΩ, 90°F/3.9kΩ, 100°F/3.2kΩ	
Gas pipe temperature thermistor	TH23		Resistance 30°F/15.8kΩ, 50°F/9.6kΩ, 70°F/6.0kΩ, 80°F/4.8kΩ, 90°F/3.9kΩ, 100°F/3.2kΩ	
Fuse (Indoor controller board)	FUSE		250V 6A	
Fan motor (with inner-thermostat)	MF		D094P45MS 208-230V 60Hz 4pole Output 45w	D10B4P70MS 208-230V 60Hz 4pole Output 70w
			Inner-thermostat	OPEN 266±9°F
Fan motor capacitor	C		2.5μF 440V	
Vane motor	MV		MP 35 EA DC12V	
Linear expansion valve	LEV		DC12V Stepping motor drive Port dimension φ3.2 (0 ~ 2,000pulse)	DC12V Stepping motor drive Port dimension φ5.2 (0 ~ 2,000pulse)
Power supply terminal block	TB2		(L1, L2, GR) 330V 30A	
Transmission terminal block	TB5		(M1, M2, S) 250V 20A	
MA remote controller terminal block	TB15		(1,2) 250V 10A	

4-3. Noise criterion curves

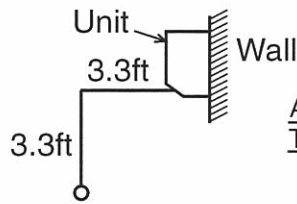

Ambient temperature 80°F
Test conditions are based on JIS Z8731

PKFY-08NAMU-A

NOTCH	SPL(dB)	LINE
Hi	36	○—○
Med1	35	△—△
Med2	33	●—●
Lo	32	▲—▲

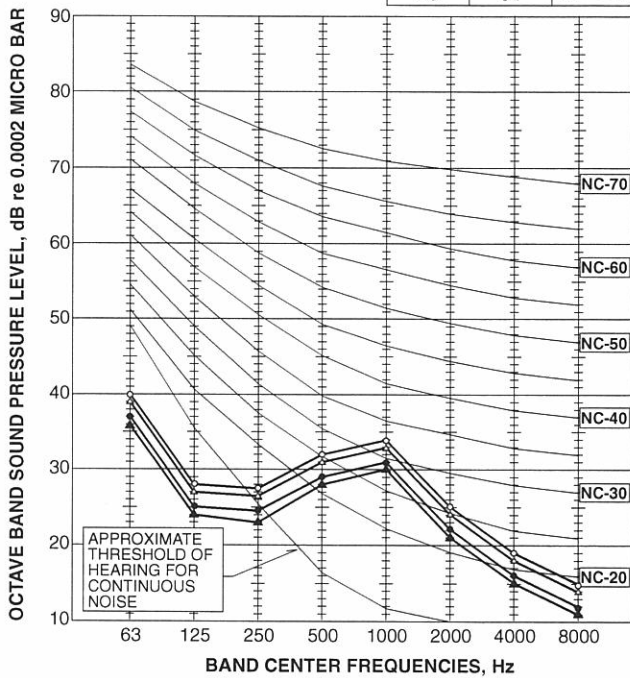

PKFY-12NGMU-A

NOTCH	SPL(dB)	LINE
Hi	42	○—○
Med1	40	△—△
Med2	36	●—●
Lo	32	▲—▲

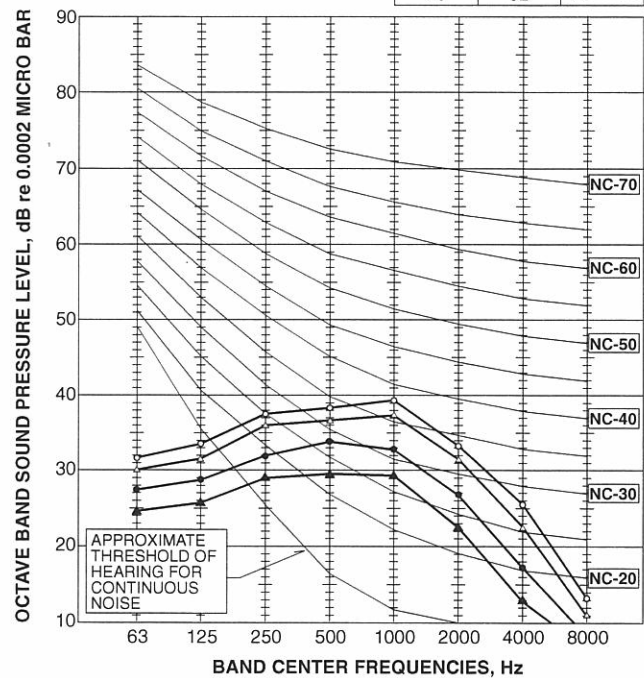

PKFY-20NFMU-A

NOTCH	SPL(dB)	LINE
Hi	45	○—○
Lo	39	●—●

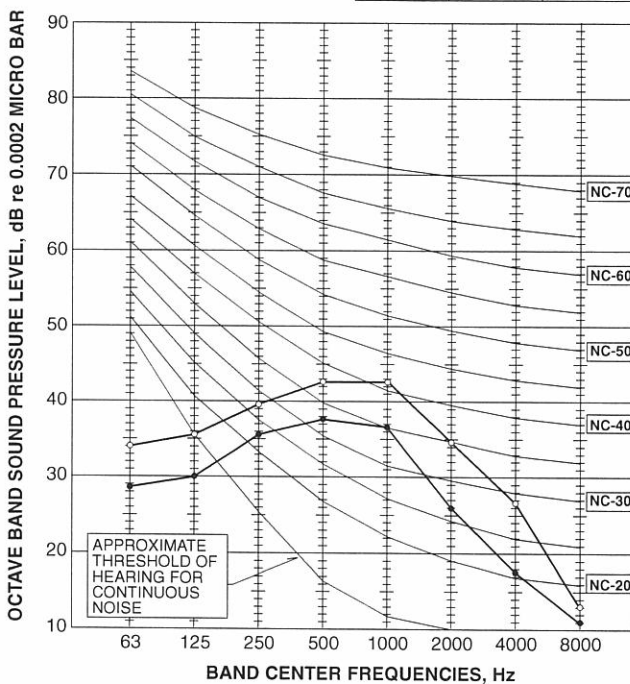

PKFY-32NFMU-A

NOTCH	SPL(dB)	LINE
Hi	49	○—○
Lo	46	●—●

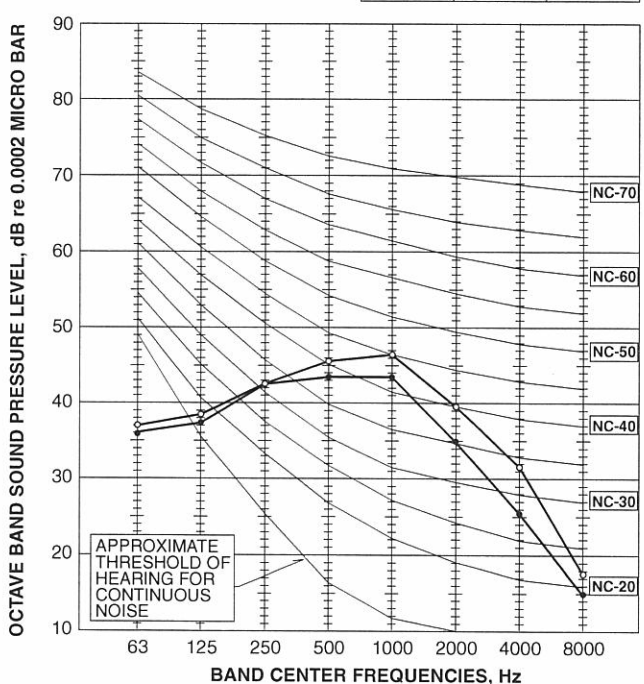

PKFY-08NAMU-A

Unit : inch(mm)

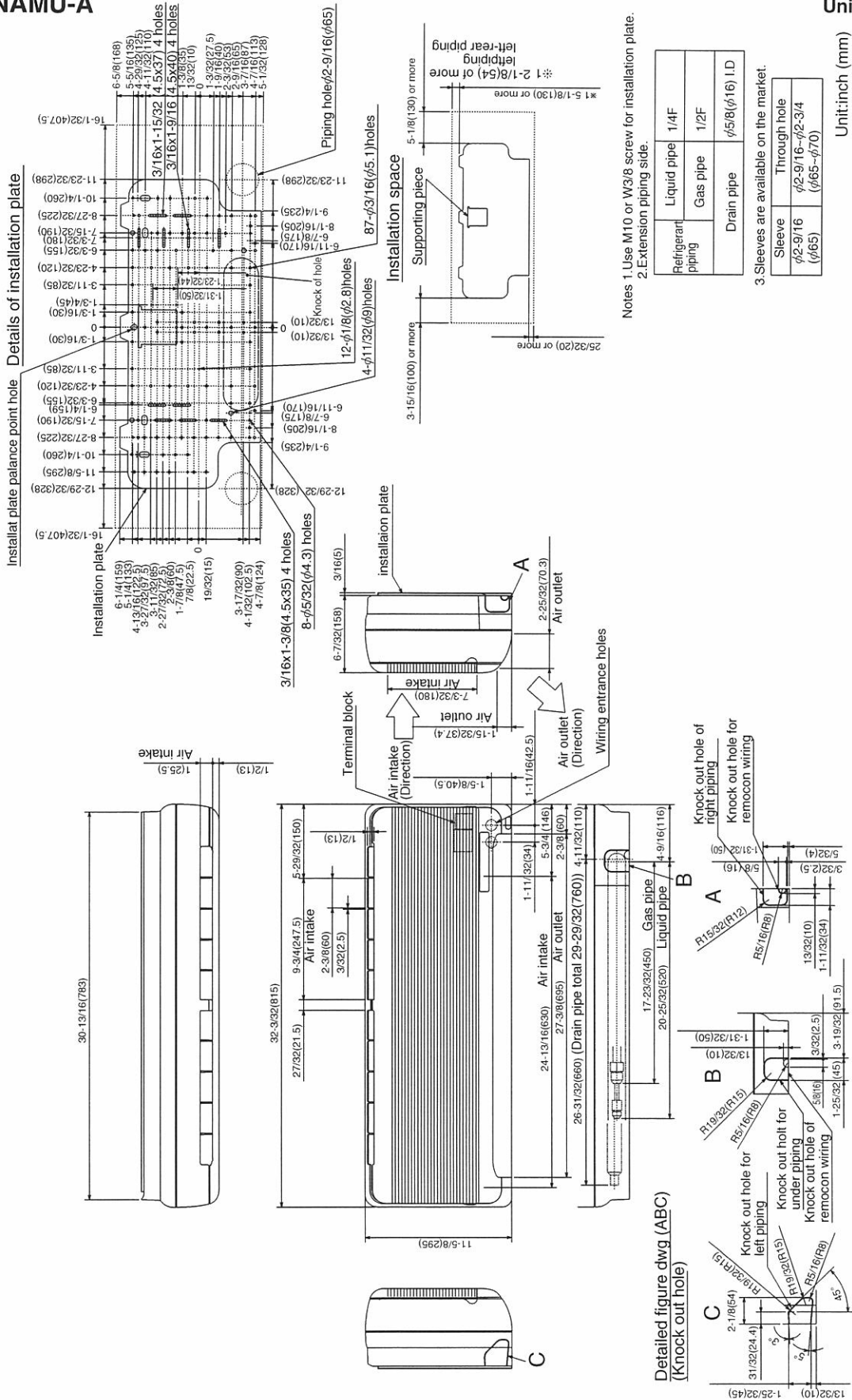

6

WIRING DIAGRAM

PKFY-08NAMU-A

[LEGEND]

SYMBOL	NAME	SYMBOL	NAME	SYMBOL	NAME	
A.B	CIRCUIT BOARD (ADDRESS)	P.B	INDOOR POWER BOARD	LEV	LINEAR EXPANSION VALVE	
SW1	SWITCH	MODE SELECTION	C	CAPACITOR (FAN MOTOR)	MF	FAN MOTOR
SW5		VOLTAGE SELECTION	F.C	FAN PHASE CONTROL	MV	VANE MOTOR
SW11		ADDRESS SETTING 1ST DIGIT	FUSE	FUSE (6A/250V)	TB2	TERMINAL BLOCK
SW12		ADDRESS SETTING 2ND DIGIT	ZNR	VARISTOR	TB5	TERMINAL BLOCK
SW14		CONNECTION No.			TH21	THERMISTOR
M.B	INDOOR CONTROLLER BOARD				TH22	ROOM TEMPERATURE DETECTION (32°F/15kΩ, 77°F/5.4kΩ)
CN32	CONNECTOR	REMOTE SWITCH			TH23	PIPE TEMPERATURE DETECTION /LIQUID (32°F/15kΩ, 77°F/5.4kΩ)
CN41		HA TERMINAL-A				PIPE TEMPERATURE DETECTION /GAS (32°F/15kΩ, 77°F/5.4kΩ)
CN51		CENTRALLY CONTROL				
CN52		REMOTE INDICATION				
SW2	SWITCH	CAPACITY CODE				
SW3		MODE SELECTION				

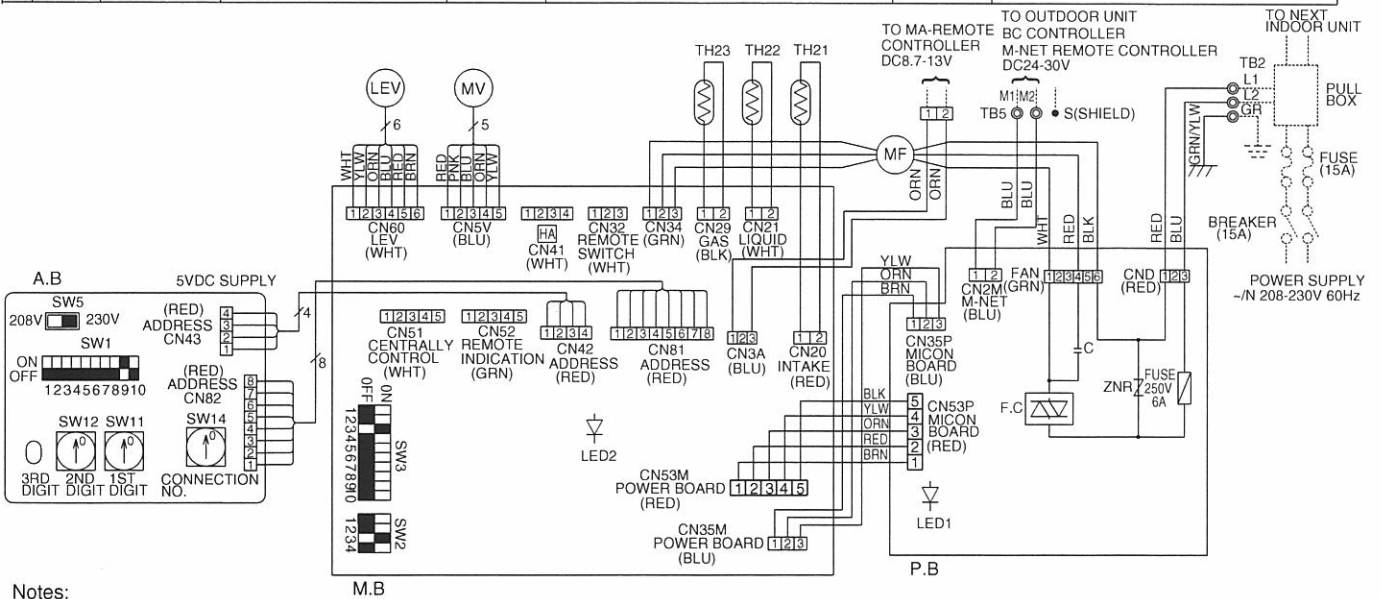

Notes:

- At servicing for outdoor unit, always follow the wiring diagram of outdoor unit.
- In case of connecting MA-Remote controller, please connect MA remote controller cable in an accessory to the connector [1][2]. (Remote controller wire is non-polar.)
- In case of using M-NET, please connect to TB5. (Transmission line is non-polar.)
- Symbols used in wiring diagram above are, ⊙: terminal block, □: connector, ●: direct wire connection.
- Please set the switch SW5 according to the power supply voltage.
Set SW5 to 230V side when the power supply is 230 volts.
When the power supply is 208 volts, set SW5 to 208V side.

LED on indoor board for service

Mark	Meaning	Function
LED1	Main power supply	Main power supply (Indoor unit: 208-230V) power on → lamp is lit
LED2	Power supply for MA-Remote controller	Power supply for MA-Remote controller on → lamp is lit

PKFY-12NGMU-A

[LEGEND]

SYMBOL	NAME	SYMBOL	NAME	SYMBOL	NAME
I.B	INDOOR CONTROLLER BOARD	C	CAPACITOR (FAN MOTOR)	TH23	THERMISTOR PIPE TEMPERATURE DETECTION/GAS (32°F/15kΩ, 77°F/5.4kΩ)
CN32	CONNECTOR REMOTE SWITCH	LEV	LINEAR EXPANSION VALVE	A.B	CIRCUIT BOARD (ADDRESS)
CN41	HA TERMINAL-A	MF	FAN MOTOR(WITH INNER THERMOSTAT)	SW1	SWITCH MODE SELECTION
CN51	CENTRALLY CONTROL	MV	VANE MOTOR	SW5	VOLTAGE SELECTION
CN52	REMOTE INDICATION	P.B	INDOOR POWER BOARD	SW11	ADDRESS SETTING 1ST DIGIT
F.C	FAN PHASE CONTROL	TB2	TERMINAL BLOCK	SW12	ADDRESS SETTING 2ND DIGIT
FUSE	FUSE (6A/250V)	TB5	TERMINAL BLOCK	SW14	CONNECTION No.
SW2	SWITCH CAPACITY CODE	TB15	TERMINAL BLOCK	SWC	OPTION SELECTOR
SW3	MODE SELECTION	TH21	THERMISTOR ROOM TEMPERATURE DETECTION (32°F/15kΩ, 77°F/5.4kΩ)		
SW4	MODEL SELECTION	TH22	THERMISTOR PIPE TEMPERATURE DETECTION/LIQUID (32°F/15kΩ, 77°F/5.4kΩ)		
X4	AUX. RELAY (FAN MOTOR)				
ZNR	VARISTOR				

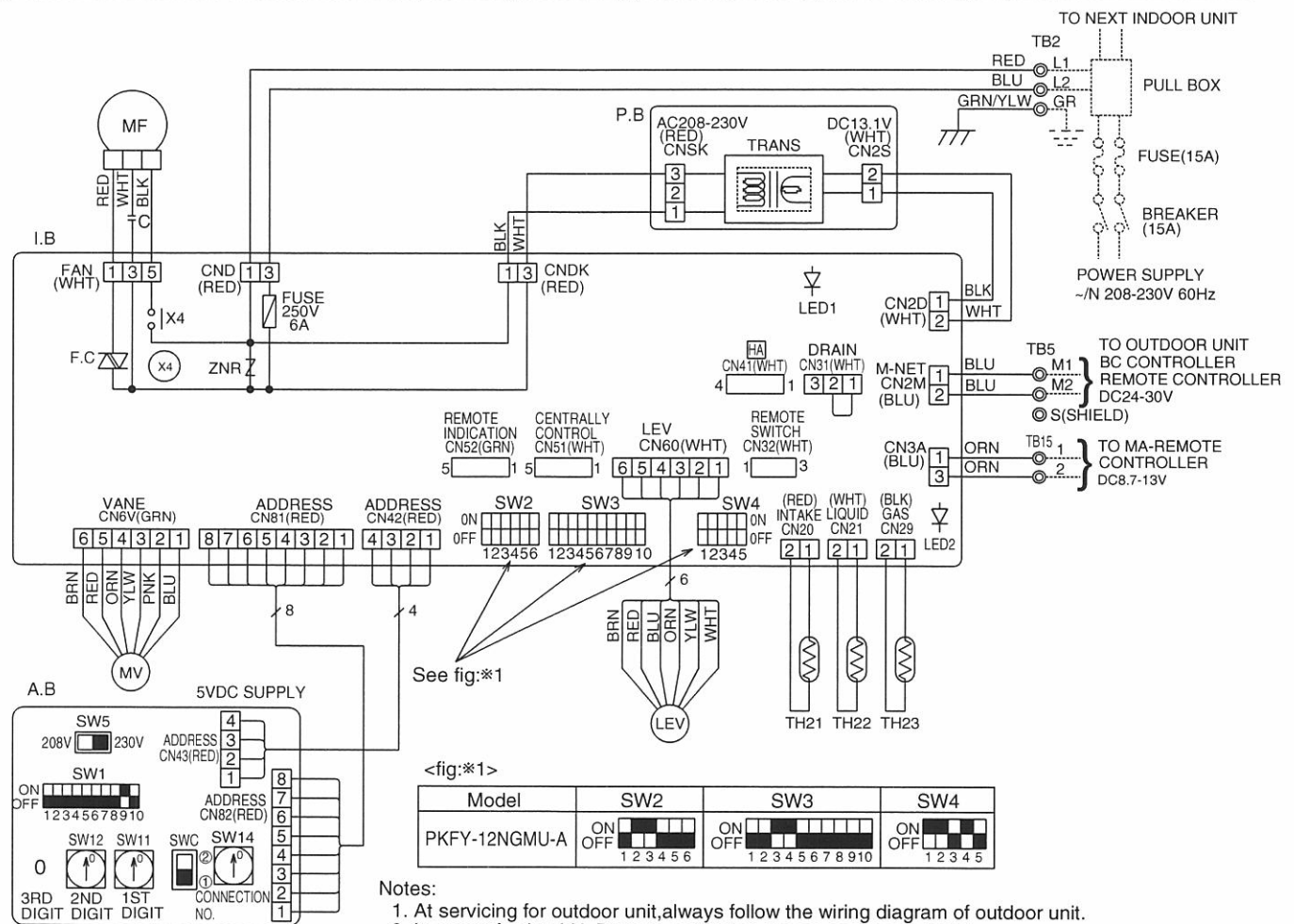

Notes:

- At servicing for outdoor unit, always follow the wiring diagram of outdoor unit.
- In case of using MA-Remote controller, please connect to TB15. (Remote controller wire is non-polar.)
- In case of using M-NET, please connect to TB5. (Transmission line is non-polar.)
- Symbol[S] of TB5 is the shield wire connection.
- Symbols used in wiring diagram above are, ⊙:terminal block, □□□:connector.
- The setting of the SW2/SW3/SW4 dip switches differs in the capacity for the detail, refer to the fig:*1.
- Please set the switch SW5 according to the power supply voltage. Set SW5 to 230V side when the power supply is 230 volts. When the power supply is 208 volts, set SW5 to 208V side.

LED on indoor board for service

Mark	Meaning	Function
LED1	Main power supply	Main power supply(Indoor unit:208-230V) power on → lamp is lit
LED2	Power supply for MA-Remote controller	Power supply for MA-Remote controller on → lamp is lit

PKFY-20NFMU-A PKFY-32NFMU-A

[LEGEND]

SYMBOL	NAME	SYMBOL	NAME	SYMBOL	NAME
I.B	INDOOR CONTROLLER BOARD	C	CAPACITOR (FAN MOTOR)	TH23	THERMISTOR PIPE TEMPERATURE DETECTION/GAS (32°F/15kΩ, 77°F/5.4kΩ)
CN32	CONNECTOR REMOTE SWITCH	LEV	LINEAR EXPANSION VALVE	A.B	CIRCUIT BOARD (ADDRESS)
CN41	HA TERMINAL-A	MF	FAN MOTOR(WITH INNER THERMOSTAT)	SW1	SWITCH MODE SELECTION
CN51	CENTRALLY CONTROL	MV	VANE MOTOR	SW5	VOLTAGE SELECTION
CN52	REMOTE INDICATION	P.B	INDOOR POWER BOARD	SW11	ADDRESS SETTING 1ST DIGIT
F.C	FAN PHASE CONTROL	TB2	TERMINAL BLOCK POWER SUPPLY	SW12	ADDRESS SETTING 2ND DIGIT
FUSE	FUSE (6A/250V)	TB5	BLOCK TRANSMISSION	SW14	CONNECTION No.
SW2	SWITCH CAPACITY CODE	TB15	MA-REMOTE CONTROLLER	SWC	OPTION SELECTOR
SW3	MODE SELECTION	TH21	THERMISTOR ROOM TEMPERATURE DETECTION (32°F/15kΩ, 77°F/5.4kΩ)		
SW4	MODEL SELECTION				
X4	AUX. RELAY (FAN MOTOR)	TH22	THERMISTOR PIPE TEMPERATURE DETECTION/LIQUID (32°F/15kΩ, 77°F/5.4kΩ)		
ZNR	VARISTOR				

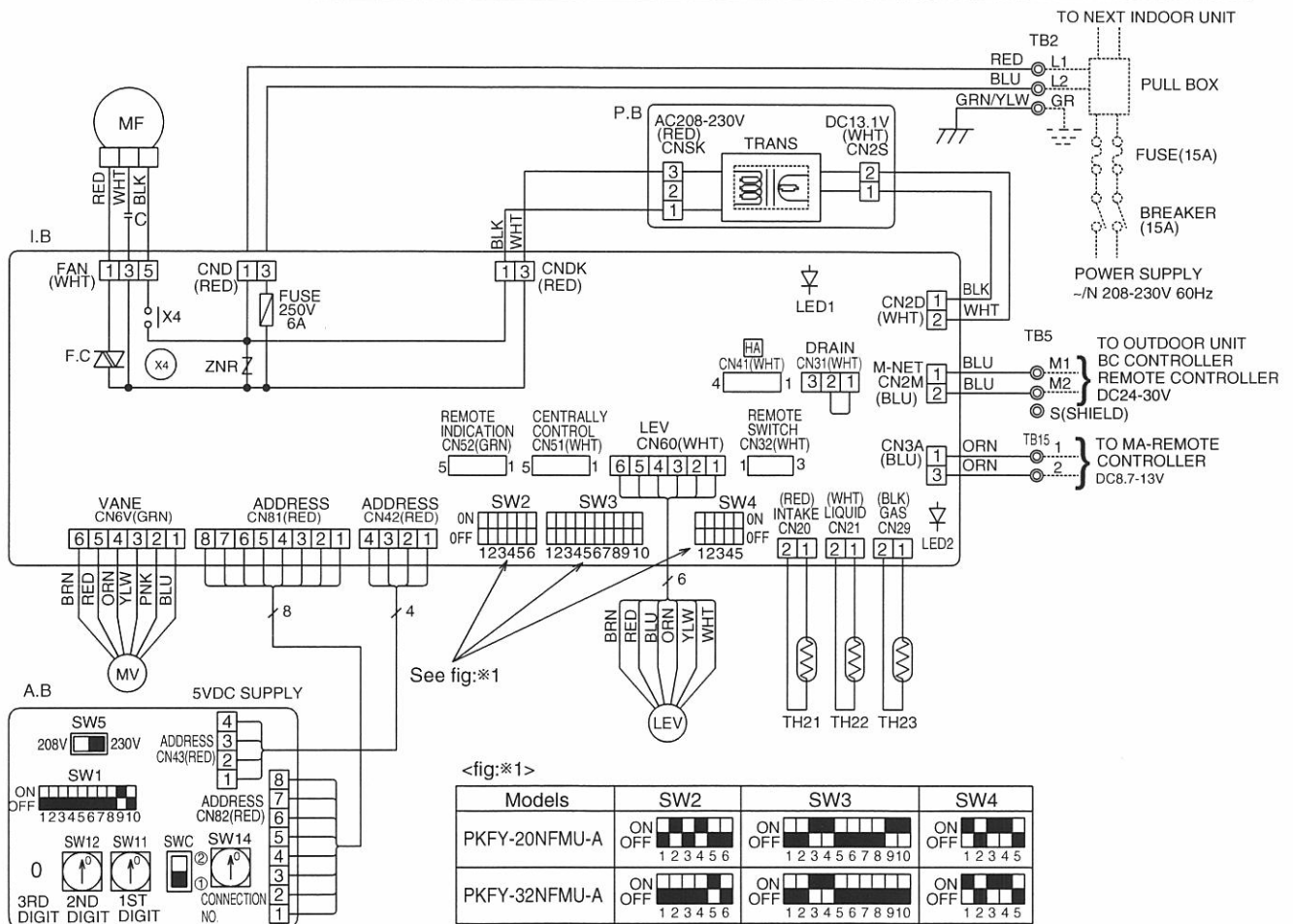

Notes:

- At servicing for outdoor unit, always follow the wiring diagram of outdoor unit.
- In case of using MA-Remote controller, please connect to TB15.
(Remote controller wire is non-polar.)
- In case of using M-NET, please connect to TB5.
(Transmission line is non-polar.)
- Symbol[S] of TB5 is the shield wire connection.
- Symbols used in wiring diagram above are, ⊕:terminal block, □:connector.
- The setting of the SW2 / SW3 / SW4 dip switches differs in the capacity for the detail, refer to the fig:*1.
- Please set the switch SW5 according to the power supply voltage.
Set SW5 to 230V side when the power supply is 230 volts.
When the power supply is 208 volts, set SW5 to 208V side.

LED on indoor board for service

Mark	Meaning	Function
LED1	Main power supply	Main power supply(Indoor unit:208-230V) power on → lamp is lit
LED2	Power supply for MA-Remote controller	Power supply for MA-Remote controller on → lamp is lit

REFRIGERANT SYSTEM DIAGRAM

PKFY-08NAMU-A

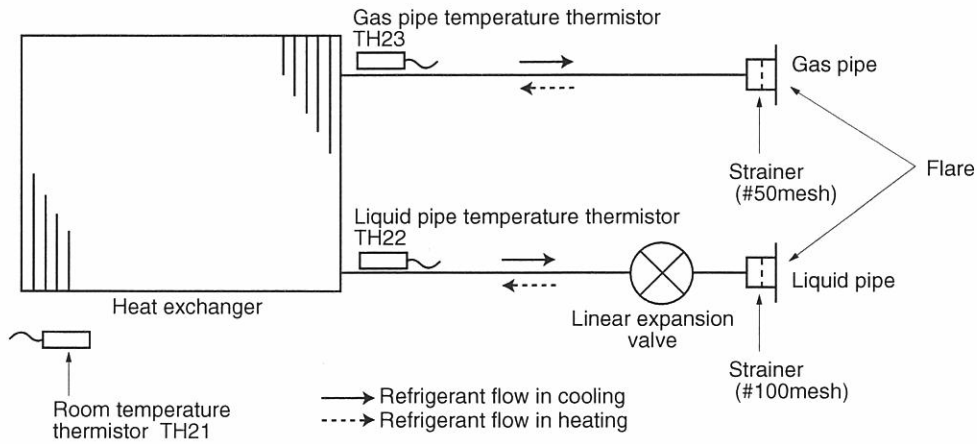

Item	Service Ref.	PKFY-08NAMU-A
Gas pipe		1/2"
Liquid pipe		1/4"

PKFY-12NGMU-A PKFY-20NFMU-A PKFY-32NFMU-A

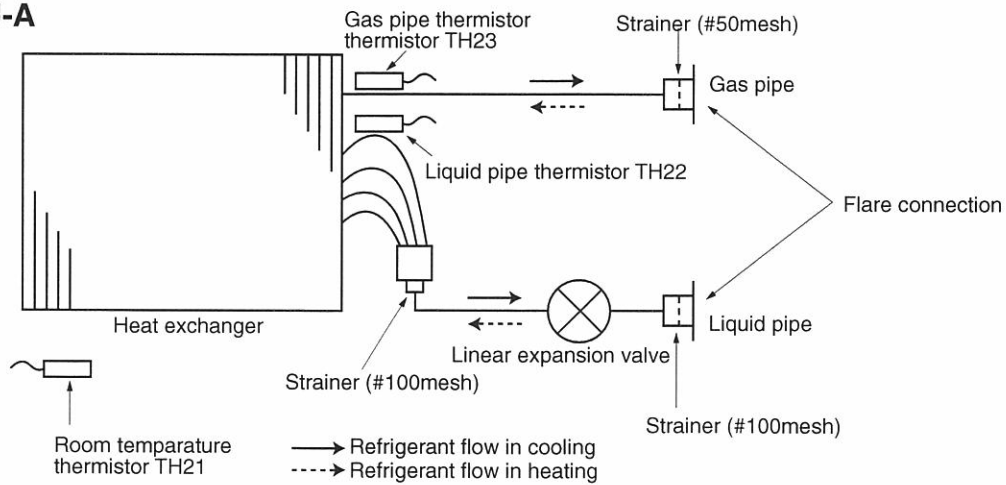

Item	Service Ref.	PKFY-12NGMU-A	PKFY-20NFMU-A PKFY-32NFMU-A
Gas pipe		1/2"	5/8"
Liquid pipe		1/4"	3/8"

INDOOR UNIT CONTROL

8-1. COOL operation

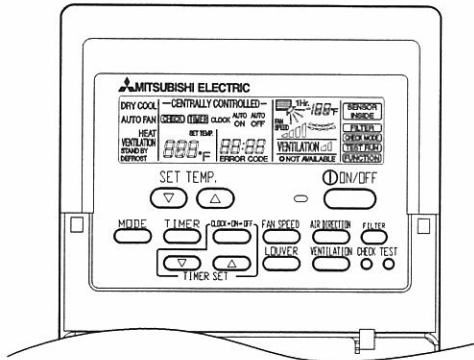

<How to operate>

- ① Press POWER ON/OFF button.
- ② Press the operation MODE button to display COOL.
- ③ Press the SET TEMP. button to set the desired temperature.

NOTE: The set temperature changes 2°F when the ∇ or Δ button is pressed one time Cooling 67 to 87°F.

Control modes	Control details	Remarks						
1. Thermoregulating function	1-1. Thermoregulating function (Function to prevent restarting for 3 minutes) <ul style="list-style-type: none"> • Room temperature \geq desired temperature + 2°F ...Thermo ON • Room temperature \leq desired temperature ...Thermo OFF 							
	1-2. Anti-freezing control <p>Detected condition : When the liquid pipe temp. (TH22) is 36°F or less in 16 minutes from compressors start up, anti-freezing control starts and the thermo OFF.</p> <p>Released condition : The timer which prevents reactivating is set for 3 minutes, and anti- freezing control is cancelled when any one of the following conditions is satisfied.</p> <ol style="list-style-type: none"> ① Liquid pipe temp. (TH22) turn 50°F or above. ② The condition of the thermo OFF has become complete by thermoregulating, etc. ③ The operation modes became mode other than COOL. ④ The operation stopped. 							
2. Fan	By the remote controller setting (switch of 4 speeds or 2 speeds) <table border="1" style="margin-left: auto; margin-right: auto;"> <thead> <tr> <th>Type</th> <th>Fan speed notch</th> </tr> </thead> <tbody> <tr> <td>4 speeds type</td> <td>[Low], [Med2], [Med1], [High]</td> </tr> <tr> <td>2 speeds type</td> <td>[Low], [High]</td> </tr> </tbody> </table>	Type	Fan speed notch	4 speeds type	[Low], [Med2], [Med1], [High]	2 speeds type	[Low], [High]	
Type	Fan speed notch							
4 speeds type	[Low], [Med2], [Med1], [High]							
2 speeds type	[Low], [High]							

To be continued on the next page.

From the preceding page.

Control modes	Control details	Remarks
<p>3. Drain pump Except for PKFY-08NAMU-A.</p>	<p>3-1. Drain pump control</p> <ul style="list-style-type: none"> •Always drain pump ON during the COOL and DRY mode operation. (Regardless of the thermo ON/ OFF) •When the operation mode has changed from the COOL or DRY to the others (including Stop), OFF the control after the drain pump ON for 3 minutes. <p>Drain sensor function</p> <ul style="list-style-type: none"> • Energize drain sensor at a fixed voltage for a fixed duration. After energizing, compare the drain sensor's temperature to the one before energizing, and judge whether the sensor is in the air or in the water. <p>Basic control system</p> <ul style="list-style-type: none"> • While drain pump is turned on, repeat the following control system and judge whether the sensor is in the air or in the water. <ul style="list-style-type: none"> •Drain sensor temperature rise (Δt) •Temperature of drain sensor before current is applied (T_0) •Temperature of drain sensor after current is applied (T_1) <p>[$\Delta t = T_1 - T_0$]</p>	<p>※1 Drain sensor Indoor control p.c. board CN31</p> <p>※2 If the unit is without the drain sensor, install the jumper connector. Indoor control p.c. board CN31</p> <p>When installing the jumper connector, determine to detect compulsorily in the air.</p>
<p>4. Vane (up/ down vane change)</p>	<p>(1) Initial setting : Start at COOL mode and horizontal vane. (2) Vane position : Horizontal →Downward A →Downward B →Downward C →Swing</p> <div style="border: 1px dashed black; padding: 5px; margin: 10px auto; width: fit-content;"> <p>PKFY-08NAMU-A is not equipped with the swing function. : Horizontal →Downward A →Downward B →Downward C</p> </div> <p>(3) In case of PKFY-08NAMU-A and PKFY-12NGMU-A : Restriction of the downward vane setting When setting the downward vane A, B or C in [Med1], [Med2] or [Low] of the fan speed notch, the vane changes to horizontal position after 1 hour have passed.</p> <p>In case of PKFY-20NFMU-A and PKFY-32NFMU-A : Restriction of the downward vane setting When setting the downward vane A, B or C in [Low] of the fan speed notch, the vane changes to horizontal position after 1 hour have passed.</p>	<p>※1 "SET FOR 1 HOUR" appears on the wired remote controller.</p>

8-2. DRY operation

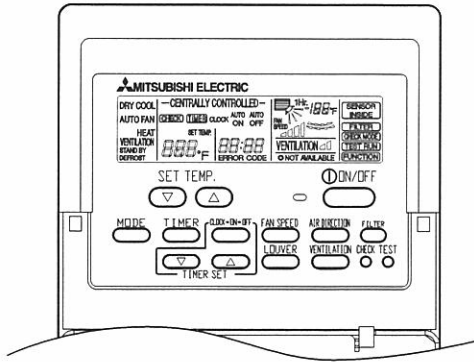

<How to operate>

- ① Press POWER ON/OFF button.
 - ② Press the operation MODE button to display DRY.
 - ③ Press the SET TEMP. button to set the desired temperature.
- NOTE:** The set temperature changes 2°F when the ∇ or Δ button is pressed one time. Dry 67 to 87°F.

Control modes	Control details	Remarks																															
1. Thermoregulating function	<p>1-1. Thermoregulating function (Function to prevent restarting for 3 minutes) Setting the Dry thermo by the thermoregulating signal and the room temperature (TH1). Dry thermo ON Room temperature \geq desired temperature + 2°F Dry thermo OFF Room temperature \leq desired temperature</p> <table border="1"> <thead> <tr> <th rowspan="2">Room temperature</th> <th colspan="2">3 min. passed since starting operation</th> <th rowspan="2">Dry thermo ON time (min)</th> <th rowspan="2">Dry thermo OFF time (min)</th> </tr> <tr> <th>Thermoregulating signal</th> <th>Room temperature (T1)</th> </tr> </thead> <tbody> <tr> <td rowspan="4">Over 64°F</td> <td rowspan="4">ON</td> <td>T1 \geq 82°F</td> <td>9</td> <td>3</td> </tr> <tr> <td>82°F > T1 \geq 79°F</td> <td>7</td> <td>3</td> </tr> <tr> <td>79°F > T1 \geq 75°F</td> <td>5</td> <td>3</td> </tr> <tr> <td>75°F > T1</td> <td>3</td> <td>3</td> </tr> <tr> <td></td> <td>OFF</td> <td>Unconditional</td> <td>3</td> <td>10</td> </tr> <tr> <td>Less than 64°F</td> <td colspan="4">Dry thermo OFF</td> </tr> </tbody> </table>	Room temperature	3 min. passed since starting operation		Dry thermo ON time (min)	Dry thermo OFF time (min)	Thermoregulating signal	Room temperature (T1)	Over 64°F	ON	T1 \geq 82°F	9	3	82°F > T1 \geq 79°F	7	3	79°F > T1 \geq 75°F	5	3	75°F > T1	3	3		OFF	Unconditional	3	10	Less than 64°F	Dry thermo OFF				
	Room temperature		3 min. passed since starting operation				Dry thermo ON time (min)	Dry thermo OFF time (min)																									
Thermoregulating signal		Room temperature (T1)																															
Over 64°F	ON	T1 \geq 82°F	9	3																													
		82°F > T1 \geq 79°F	7	3																													
		79°F > T1 \geq 75°F	5	3																													
		75°F > T1	3	3																													
	OFF	Unconditional	3	10																													
Less than 64°F	Dry thermo OFF																																
	<p>1-2. Frozen prevention control No control function</p>																																
2. Fan	<p>Indoor fan operation controlled depends on the compressor conditions.</p> <table border="1"> <thead> <tr> <th>Dry thermo</th> <th>Fan speed notch</th> </tr> </thead> <tbody> <tr> <td>ON</td> <td>[Low]</td> </tr> <tr> <td>OFF</td> <td>Stop</td> </tr> </tbody> </table> <p>Note: Remote controller setting is not acceptable.</p>	Dry thermo	Fan speed notch	ON	[Low]	OFF	Stop																										
Dry thermo	Fan speed notch																																
ON	[Low]																																
OFF	Stop																																
3. Drain pump Except for PKFY-08NAMU-A.	Same control as COOL operation																																
4. Vane (up/ down vane change)	Same control as COOL operation																																

8-3. FAN operation

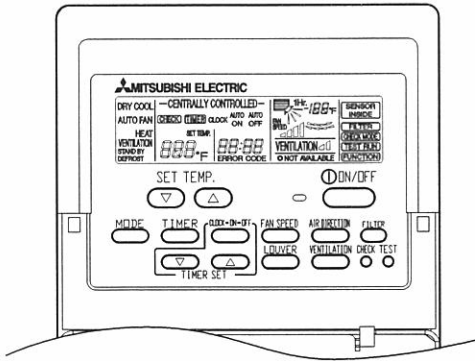

<How to operate>

- ① Press POWER ON/OFF button.
- ② Press the operation MODE button to display FAN.

Control modes	Control details	Remarks						
1. Fan	Set by remote controller. <table border="1" data-bbox="400 884 1010 996" style="margin-left: auto; margin-right: auto;"> <thead> <tr> <th>Type</th> <th>Fan speed notches</th> </tr> </thead> <tbody> <tr> <td>4 speeds type</td> <td>[Low], [Med2], [Med1], [High]</td> </tr> <tr> <td>2 speeds type</td> <td>[Low], [High]</td> </tr> </tbody> </table>	Type	Fan speed notches	4 speeds type	[Low], [Med2], [Med1], [High]	2 speeds type	[Low], [High]	
Type	Fan speed notches							
4 speeds type	[Low], [Med2], [Med1], [High]							
2 speeds type	[Low], [High]							
2. Vane (up/ down vane change)	Same as the control performed during the COOL operation, but with no restriction on the vane's downward blow setting.							

8-4. HEAT operation

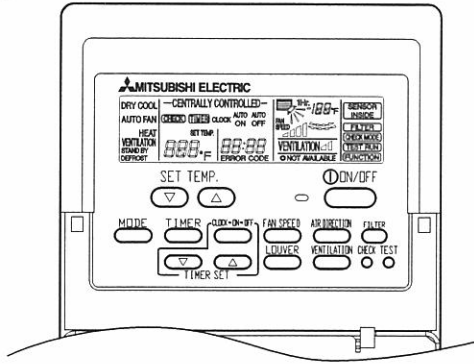

<How to operate>

- ① Press POWER ON/OFF button.
- ② Press the operation MODE button to display HEAT.
- ③ Press the SET TEMP. button to set the desired temperature.

NOTE: The set temperature changes 2°F when the ∇ or Δ button is pressed one time. Heating 63 to 83°F.

<Display in HEAT operation>

[DEFROST]

The [DEFROST] symbol is only displayed during the defrost operation.

[STANDBY]

The [STANDBY] symbol is only displayed from the time the heating operation starts until the heated air begins to blow.

Control modes	Control details	Remarks
1. Thermoregulating function	<p>1-1. Thermoregulating function (Function to prevent restarting for 3 minutes)</p> <ul style="list-style-type: none"> •Room temp. \leq desired temp.30°F ...Thermo ON •Room temp. \geq desired temp. ...Thermo OFF 	
2. Fan	<p>Controlled by the remote controller (4-speed) Give priority to under-mentioned controlled mode</p> <p>2-1. Hot adjuster mode 2-2. Preheating exclusion mode 2-3. Thermo OFF mode (When the compressor off by the thermoregulating) 2-4. Cool air prevention mode (Defrosting mode) 2-5. Capacity increasing mode</p>	<p>*1 Fan speed change notch Refer to the model function table</p>
	<p>2-1. Hot adjuster mode The fan controller becomes the hot adjuster mode for the following conditions.</p> <ol style="list-style-type: none"> ① When starting the HEAT operation ② When starting the compressor by the thermoregulating ③ When release the HEAT defrosting operation <p style="text-align: center;">Hot adjuster mode *1</p> <p>A: HOT adjuster mode start B: 5 min have passed since the condition A or the indoor Condenser/ Evaporator temp. turned 65°F or more C: 2 min have passed since the condition A (Terminating the hot adjuster mode)</p>	<p>*1 "STAND BY" will be displayed during the hot adjuster mode.</p>

To be continued on the next page.

From the preceding page.

Control modes	Control details	Remarks
2. Fan	2-2. Preheating exclusion mode When the condition changes the auxiliary heater ON to OFF (thermoregulating or operation stop, etc), the indoor fan operates in [Low] mode for 1 minute.	*1 This control is same for the model without auxiliary heater.
	2-3. Thermo OFF mode When the thermoregulating function changes to OFF, the indoor fan operates in [Extra low].	
	2-4. Heat defrosting mode The indoor fan stops.	
3. Vane control (Up/ down vane change)	(1) Initial setting : OFF → HEAT...[last setting] When changing the mode from exception of HEAT to HEAT operation. ...[Downward C] (2) Vane position : Horizontal →Downward A →Downward B →Downward C→Swing _____ PKFY-08NAMU-A is not equipped with the swing function. Horizontal →Downward A →Downward B →Downward C _____ (3) Restriction of vane position ① The vane is horizontally fixed for the following modes. (The control by the remote controller is temporally invalidated and control by the unit.) •Thermo OFF •Hot adjuster [Extra low] mode •Heat defrost mode	

8-5. AUTO operation [Automatic COOL/HEAT change over operation]

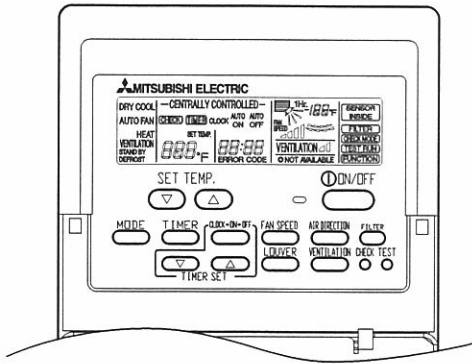

<How to operate>

- ① Press POWER ON/OFF button.
- ② Press the operation MODE button to display AUTO.
- ③ Press the SET TEMP. button to set the desired temperature.

NOTE: The set temperature changes 2°F when the ∇ or \triangle button is pressed one time. Automatic 67 to 83°F.
 "AUTO" works to change by itself the operation mode either to cooling or heating to the room temperature.

Control modes	Control details	Remarks
1. Initial value of operation mode	HEAT mode for room temperature < Desired temperature COOL mode for room temperature \geq Desired temperature	
2. Mode change	(1) HEAT mode \rightarrow COOL mode Room temperature \geq Desired temperature + 4°F. or 15 min. has passed (2) COOL mode \rightarrow HEAT mode Room temperature \leq Desired temperature - 4°F. or 15 min. has passed	
3. COOL mode	Same control as cool operation	
4. HEAT mode	Same control as heat operation	

8-6. TIMER operation

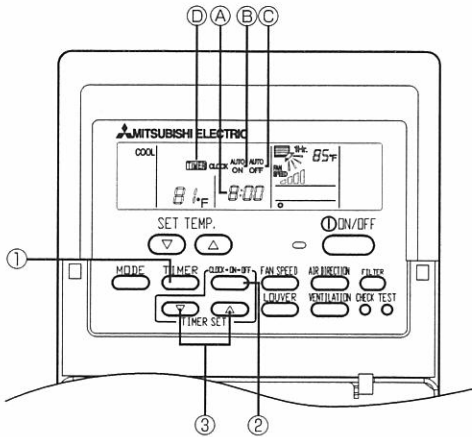
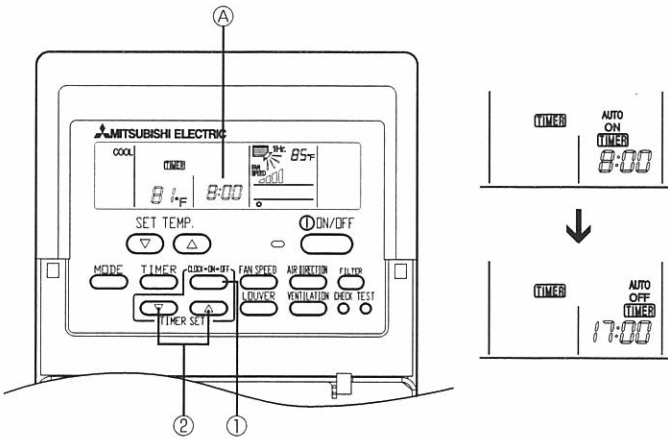

1) Set the current time

- 1) Press CLOCK-ON-OFF button to display the "current time" (A).

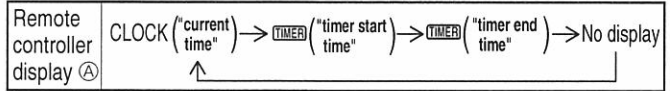

- 2) Each time you press (▲) button, the time increases in increments of one minute. Each time you press (▼) button, the time decreases in increments of one minute.

- Press and hold the button to rapidly change the time.
- The time changes in increments of one minute → ten minutes → in units of hour; in this order.

- Approximately ten seconds after pressing the button, the display on the remote controller will turn off.

The example shows a timer set for operation start at 8:00 and end at 17:00.

2) set the mode to continuous as follows

- 1) Press TIMER button to display (D) (TIMER).

3) Set the time to start the unit as follows

- 2) Press CLOCK-ON-OFF button to display (B) ON.
- 3) Press (▼) (▲) button to set the time that you want the unit to start. The start time is displayed at (A).

4) Set the time to stop the unit as follows

- 2) Press CLOCK-ON-OFF button to display (C) OFF.
- 3) Press (▼) (▲) button to set the time that you want the unit to stop. The stop time is displayed at (A).

5) Set the mode to timer as follows

- 1) Press TIMER button to display (D) (TIMER).

9

TROUBLESHOOTING

9-1. How to check PKFY-08NAMU-A

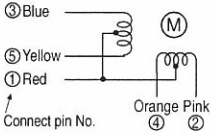
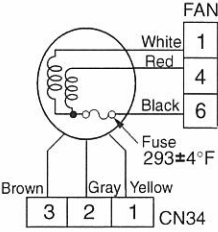
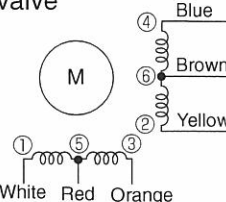
Part Name	Check points														
Room temperature thermistor(TH21) Liquid pipe temperature thermistor(TH22) Gas pipe temperature thermistor(TH23)	Disconnect the connector, then measure the resistance using a tester. (Surrounding temperature 50°F~86°F) <table border="1" data-bbox="411 506 922 584"> <thead> <tr> <th>Normal</th> <th>Abnormal</th> </tr> </thead> <tbody> <tr> <td>4.3kΩ~9.6kΩ</td> <td>Open or short</td> </tr> </tbody> </table> (Refer to page OC292-36 for details.)	Normal	Abnormal	4.3kΩ~9.6kΩ	Open or short										
Normal	Abnormal														
4.3kΩ~9.6kΩ	Open or short														
Vane motor 	①Measure the resistance between the terminals using a tester.(Surrounding temperature 77°F.) <table border="1" data-bbox="411 689 1262 842"> <thead> <tr> <th colspan="4">Normal</th> <th>Abnormal</th> </tr> </thead> <tbody> <tr> <td>①-② Red-Pink</td> <td>①-③ Red-Blue</td> <td>①-④ Red-Orange</td> <td>①-⑤ Red-Yellow</td> <td rowspan="2">Open or short</td> </tr> <tr> <td colspan="4" style="text-align: center;">400Ω ± 7%</td> </tr> </tbody> </table>	Normal				Abnormal	①-② Red-Pink	①-③ Red-Blue	①-④ Red-Orange	①-⑤ Red-Yellow	Open or short	400Ω ± 7%			
Normal				Abnormal											
①-② Red-Pink	①-③ Red-Blue	①-④ Red-Orange	①-⑤ Red-Yellow	Open or short											
400Ω ± 7%															
Fan motor 	①Measure the resistance between the terminals using a tester.(Surrounding temperature 68°F.) <table border="1" data-bbox="411 920 1243 1032"> <thead> <tr> <th></th> <th>Normal</th> <th>Abnormal</th> </tr> </thead> <tbody> <tr> <td>White-Black</td> <td>195Ω</td> <td rowspan="2">Open or short</td> </tr> <tr> <td>Red-Black</td> <td>200Ω</td> </tr> </tbody> </table> ②Without disassembling the parts, measure the electrical pressure of the gray wire(Signal line) and brown wire (GND) while the power is on. <table border="1" data-bbox="411 1160 1390 1379"> <tbody> <tr> <td>Normal</td> <td>(1)At first, check if the electrical pressure is 12V between the brown wire(GND) and yellow wire(VCC). (2)Slowly start running the fan. It is normal if while the fan rotate once, the electrical pressure change from 0V to 12V then go back to 0V.</td> </tr> <tr> <td>Abnormal</td> <td>If the electrical pressure stay at around 0V or 10V, it means the fan motor has the defects.</td> </tr> </tbody> </table>		Normal	Abnormal	White-Black	195Ω	Open or short	Red-Black	200Ω	Normal	(1)At first, check if the electrical pressure is 12V between the brown wire(GND) and yellow wire(VCC). (2)Slowly start running the fan. It is normal if while the fan rotate once, the electrical pressure change from 0V to 12V then go back to 0V.	Abnormal	If the electrical pressure stay at around 0V or 10V, it means the fan motor has the defects.		
	Normal	Abnormal													
White-Black	195Ω	Open or short													
Red-Black	200Ω														
Normal	(1)At first, check if the electrical pressure is 12V between the brown wire(GND) and yellow wire(VCC). (2)Slowly start running the fan. It is normal if while the fan rotate once, the electrical pressure change from 0V to 12V then go back to 0V.														
Abnormal	If the electrical pressure stay at around 0V or 10V, it means the fan motor has the defects.														
Linear expansion valve 	Disconnect the connector then measure the resistance valve using a tester. (Coil temperature 68°F) <table border="1" data-bbox="411 1480 1257 1632"> <thead> <tr> <th colspan="4">Normal</th> <th>Abnormal</th> </tr> </thead> <tbody> <tr> <td>①-⑤ White-Red</td> <td>②-⑥ Yellow-Brown</td> <td>③-⑤ Orange-Red</td> <td>④-⑥ Blue-Brown</td> <td rowspan="2">Open or short</td> </tr> <tr> <td colspan="4" style="text-align: center;">150Ω ±10%</td> </tr> </tbody> </table> (Refer to page OC292-36 for details.)	Normal				Abnormal	①-⑤ White-Red	②-⑥ Yellow-Brown	③-⑤ Orange-Red	④-⑥ Blue-Brown	Open or short	150Ω ±10%			
Normal				Abnormal											
①-⑤ White-Red	②-⑥ Yellow-Brown	③-⑤ Orange-Red	④-⑥ Blue-Brown	Open or short											
150Ω ±10%															

PKFY-12NGMU-A

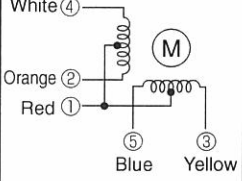
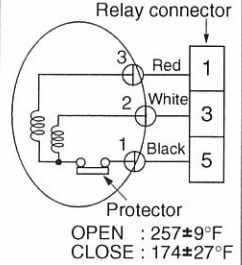
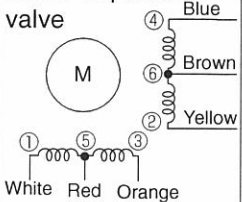
Parts name	Check points																			
Room temperature thermistor (TH21) Liquid pipe thermistor (TH22) Gas pipe thermistor (TH23)	Disconnect the connector then measure the resistance using a tester. (Surrounding temperature 50°F~86°F) <table border="1" data-bbox="352 533 865 607"> <thead> <tr> <th>Normal</th> <th>Abnormal</th> </tr> </thead> <tbody> <tr> <td>4.3kΩ~9.6kΩ</td> <td>Open or short</td> </tr> </tbody> </table> (Refer to page OC292-36 for details.)	Normal	Abnormal	4.3kΩ~9.6kΩ	Open or short															
Normal	Abnormal																			
4.3kΩ~9.6kΩ	Open or short																			
Vane motor 	Measure the resistance between the terminals using a tester. (Surrounding temperature 68°F~86°F) <table border="1" data-bbox="352 734 1093 922"> <thead> <tr> <th>Connector</th> <th>Normal</th> <th>Abnormal</th> </tr> </thead> <tbody> <tr> <td>Red — Yellow</td> <td rowspan="4">186Ω~214Ω</td> <td rowspan="4">Open or short</td> </tr> <tr> <td>Red — Blue</td> </tr> <tr> <td>Red — Orange</td> </tr> <tr> <td>Red — White</td> </tr> </tbody> </table>	Connector	Normal	Abnormal	Red — Yellow	186Ω~214Ω	Open or short	Red — Blue	Red — Orange	Red — White										
Connector	Normal	Abnormal																		
Red — Yellow	186Ω~214Ω	Open or short																		
Red — Blue																				
Red — Orange																				
Red — White																				
Fan motor 	Measure the resistance between the terminals using a tester. (Surrounding temperature 68°F) <table border="1" data-bbox="352 1037 1129 1189"> <thead> <tr> <th>Motor terminal or Relay connector</th> <th>Normal</th> <th>Abnormal</th> </tr> </thead> <tbody> <tr> <td>Red-Black</td> <td>141.2Ω</td> <td rowspan="2">Open or short</td> </tr> <tr> <td>White-Black</td> <td>131.5Ω</td> </tr> </tbody> </table>	Motor terminal or Relay connector	Normal	Abnormal	Red-Black	141.2Ω	Open or short	White-Black	131.5Ω											
Motor terminal or Relay connector	Normal	Abnormal																		
Red-Black	141.2Ω	Open or short																		
White-Black	131.5Ω																			
Linear expansion valve 	Disconnect the connector then measure the resistance with the tester. (Surrounding temperature 68°F) <table border="1" data-bbox="352 1391 1214 1541"> <thead> <tr> <th colspan="4">Normal</th> <th>Abnormal</th> </tr> <tr> <th>① - ⑤</th> <th>② - ⑥</th> <th>③ - ⑤</th> <th>④ - ⑥</th> <th rowspan="2">Open or short</th> </tr> </thead> <tbody> <tr> <td>White-Red</td> <td>Yellow-Brown</td> <td>Orange-Red</td> <td>Blue-Brown</td> </tr> <tr> <td colspan="4" style="text-align: center;">150Ω ±10%</td> <td></td> </tr> </tbody> </table> (Refer to page OC292-36 for details.)	Normal				Abnormal	① - ⑤	② - ⑥	③ - ⑤	④ - ⑥	Open or short	White-Red	Yellow-Brown	Orange-Red	Blue-Brown	150Ω ±10%				
Normal				Abnormal																
① - ⑤	② - ⑥	③ - ⑤	④ - ⑥	Open or short																
White-Red	Yellow-Brown	Orange-Red	Blue-Brown																	
150Ω ±10%																				

PKFY-20NFMU-A
PKFY-32NFMU-A

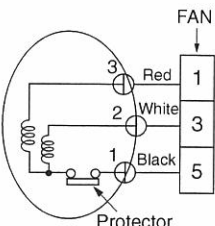
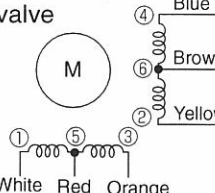
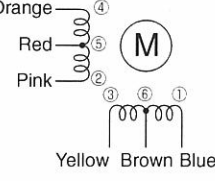
Parts name	Check points																		
Room temperature thermistor (TH21) Liquid pipe temperature thermistor (TH22) Gas pipe temperature thermistor (TH23)	Disconnect the connector then measure the resistance using a tester. (Surrounding temperature 50°F~86°F) <table border="1" data-bbox="416 517 927 595" style="margin-left: 20px;"> <tr> <td>Normal</td> <td>Abnormal</td> </tr> <tr> <td>4.3kΩ~9.6kΩ</td> <td>Open or short</td> </tr> </table> (Refer to page OC292-36 for details.)	Normal	Abnormal	4.3kΩ~9.6kΩ	Open or short														
Normal	Abnormal																		
4.3kΩ~9.6kΩ	Open or short																		
Fan motor  <p>Protector OPEN : 266±9°F CLOSE : 181±27°F</p>	Measure the resistance between the terminals using a tester. (Surrounding temperature 68°F) <table border="1" data-bbox="416 719 1457 875" style="margin-left: 20px;"> <thead> <tr> <th rowspan="2">Motor terminal or Relay connector</th> <th colspan="2">Normal</th> <th rowspan="2">Abnormal</th> </tr> <tr> <th>PKFY-20NFMU-A</th> <th>PKFY-32NFMU-A</th> </tr> </thead> <tbody> <tr> <td>Red-Black</td> <td>99.5Ω ±10%</td> <td>62.6Ω ±10%</td> <td rowspan="2">Open or short</td> </tr> <tr> <td>White-Black</td> <td>103.5Ω ±10%</td> <td>74.0Ω ±10%</td> </tr> </tbody> </table>	Motor terminal or Relay connector	Normal		Abnormal	PKFY-20NFMU-A	PKFY-32NFMU-A	Red-Black	99.5Ω ±10%	62.6Ω ±10%	Open or short	White-Black	103.5Ω ±10%	74.0Ω ±10%					
Motor terminal or Relay connector	Normal		Abnormal																
	PKFY-20NFMU-A	PKFY-32NFMU-A																	
Red-Black	99.5Ω ±10%	62.6Ω ±10%	Open or short																
White-Black	103.5Ω ±10%	74.0Ω ±10%																	
Linear expansion valve 	Disconnect the connector then measure the resistance valve using a tester. (Surrounding temperature 68°F) <table border="1" data-bbox="416 1055 1273 1205" style="margin-left: 20px;"> <thead> <tr> <th colspan="4">Normal</th> <th rowspan="2">Abnormal</th> </tr> <tr> <th>① - ⑤</th> <th>② - ⑥</th> <th>③ - ⑤</th> <th>④ - ⑥</th> </tr> </thead> <tbody> <tr> <td>White-Red</td> <td>Yellow-Brown</td> <td>Orange-Red</td> <td>Blue-Brown</td> <td rowspan="2">Open or short</td> </tr> <tr> <td colspan="4" style="text-align: center;">150Ω ±10%</td> </tr> </tbody> </table> (Refer to page OC292-36 for details.)	Normal				Abnormal	① - ⑤	② - ⑥	③ - ⑤	④ - ⑥	White-Red	Yellow-Brown	Orange-Red	Blue-Brown	Open or short	150Ω ±10%			
Normal				Abnormal															
① - ⑤	② - ⑥	③ - ⑤	④ - ⑥																
White-Red	Yellow-Brown	Orange-Red	Blue-Brown	Open or short															
150Ω ±10%																			
Vane motor 	Measure the resistance between the terminals using a tester. (Surrounding temperature 68°F~86°F) <table border="1" data-bbox="416 1305 1050 1496" style="margin-left: 20px;"> <thead> <tr> <th>Connector</th> <th>Normal</th> <th>Abnormal</th> </tr> </thead> <tbody> <tr> <td>Brown — Yellow</td> <td rowspan="4" style="text-align: center;">186~214Ω</td> <td rowspan="4" style="text-align: center;">Open or short</td> </tr> <tr> <td>Brown — Blue</td> </tr> <tr> <td>Red — Orange</td> </tr> <tr> <td>Red — Pink</td> </tr> </tbody> </table>	Connector	Normal	Abnormal	Brown — Yellow	186~214Ω	Open or short	Brown — Blue	Red — Orange	Red — Pink									
Connector	Normal	Abnormal																	
Brown — Yellow	186~214Ω	Open or short																	
Brown — Blue																			
Red — Orange																			
Red — Pink																			

<Thermistor characteristic graph>

Thermistor for lower temperature

- Room temperature thermistor (TH21)
- Liquid pipe temperature thermistor (TH22)
- Gas pipe temperature thermistor (TH23)

Thermistor $R_0 = 15k\Omega \pm 3\%$
 Fixed number of $B = 3480k\Omega \pm 2\%$

$$R_t = 15 \exp \left\{ 3480 \left(\frac{1}{273 + (t-32)/1.8} - \frac{1}{273} \right) \right\}$$

30°F	15.8kΩ
50°F	9.6kΩ
70°F	6.0kΩ
80°F	4.8kΩ
90°F	3.9kΩ
100°F	3.2kΩ

< Thermistor for lower temperature >

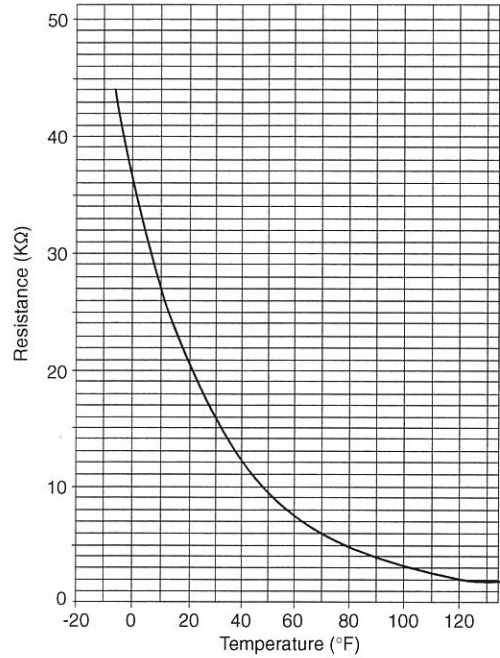

Linear expansion valve

① Operation summary of the linear expansion valve.

- Linear expansion valve open/close through stepping motor after receiving the pulse signal from the indoor controller board.
- Valve position can be changed in proportion to the number of pulse signal.

<Connection between the indoor controller board and the linear expansion valve>

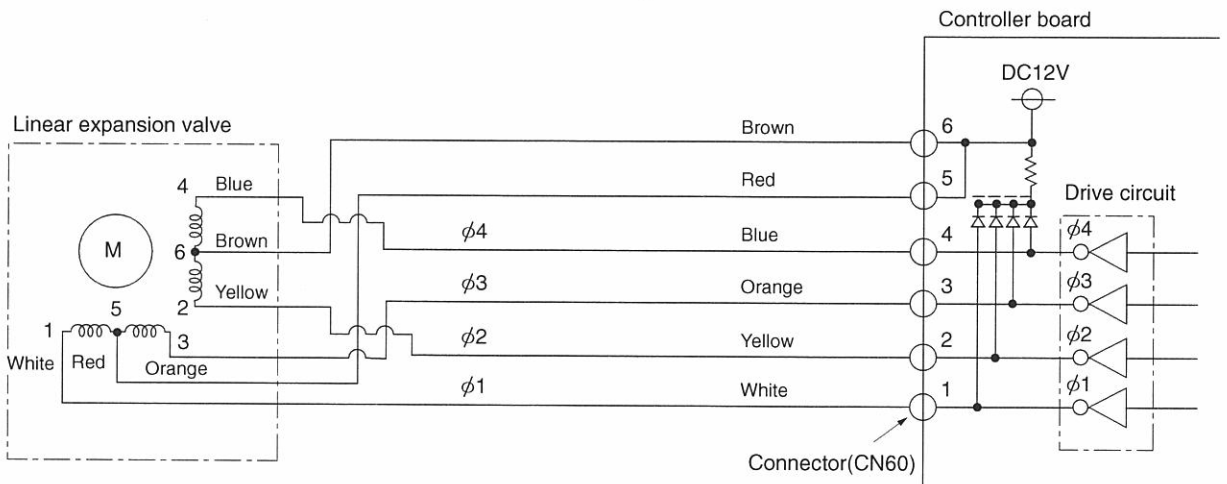

Note : Since the number of the connector at the controller board side and the relay connector are different, follow the color of the lead wire.

<Output pulse signal and the valve operation>

Output (Phase)	Output			
	1	2	3	4
$\phi 1$	ON	OFF	OFF	ON
$\phi 2$	ON	ON	OFF	OFF
$\phi 3$	OFF	ON	ON	OFF
$\phi 4$	OFF	OFF	ON	ON

Closing a valve : 1 → 2 → 3 → 4 → 1
 Opening a valve : 4 → 3 → 2 → 1 → 4

The output pulse shifts in above order.

- * 1. When linear expansion valve operation stops, all output phase become OFF.
- 2. At phase interruption or when phase does not shift in order, motor does not rotate smoothly and motor will lock and vibrates.

② Linear expansion valve operation

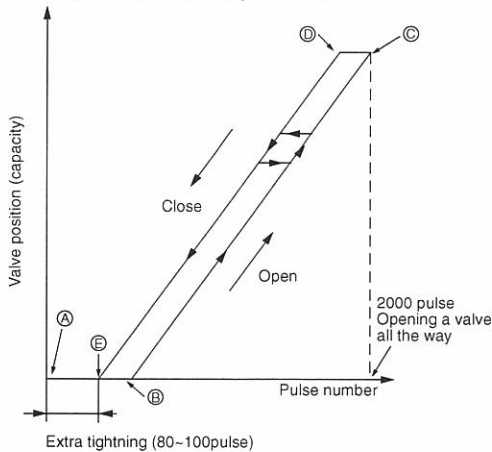

- * When the switch is turned on, 2200 pulse closing valve signal will be send till it goes to A point in order to define the valve position.

When the valve moves smoothly, there is no noise or vibration occurring from the linear expansion valve : however, when the pulse number moves from E to A or when the valve is locked, more noise can be heard than normal situation.

- * Noise can be detected by placing the ear against the screw driver handle while putting the screw driver to the linear expansion valve.

③ Trouble shooting

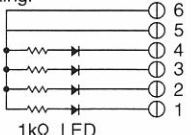
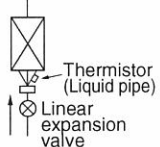
Symptom	Check points	Countermeasures
Operation circuit failure of the micro processor.	Disconnect the connector on the controller board, then connect LED for checking.  Pulse signal will be sent out for 10 seconds as soon as the main switch is turn on. If there is LED with lights on or lights off, it means the operation circuit is abnormal.	Exchange the indoor controller board at drive circuit failure.
Linear expansion valve mechanism is locked.	Motor will idle and make ticking noise when motor is operated while the linear expansion valve is locked. This ticking sound is the sign of the abnormality.	Exchange the linear expansion vale.
Short or breakage of the motor coil of the linear expansion valve.	Measure the resistance between the each coil (red-white, red-orange, brown-yellow, brown-blue) using a tester. It is normal if the resistance is in the range of $150\Omega \pm 10\%$.	Exchange the linear expansion valve.
Valve doesn't close completely (thermistor leaking).	To check the linear expansion valve, operate the indoor unit in fan mode and at the same time operate other indoor units in cooling mode, then check the pipe temperature <liquid pipe temperature> of the indoor unit by the outdoor multi controller board operation monitor. During fan operation, linear expansion valve is closed completely and if there are some leaking, detecting temperature of the thermistor will go lower. If the detected temperature is much lower than the temperature indicated in the remote controller, it means the valve is not closed all the way. It is not necessary to exchange the linear expansion valve, if the leakage is small and not making any trouble. 	If large amount of thermistor is leaked, exchange the linear expansion valve.
Wrong connection of the connector or contact failure.	Check the color of lead wire and missing terminal of the connector.	Disconnect the connector at the controller board, then check the continuity.







9-2. FUNCTION OF DIP SWITCH PKFY-08NAMU-A

Switch	Pole	Function	Operation by switch		Remarks																				
			ON	OFF																					
SW1 Mode Selection	1	Thermistor <intake temperature detection> position	Built-in remote controller	Indoor unit	<div style="border: 1px solid black; padding: 2px; display: inline-block;">Address board</div> <At delivery> ON <table border="1" style="display: inline-table; vertical-align: middle;"><tr><td> </td><td> </td><td> </td><td> </td><td> </td><td> </td><td> </td><td> </td><td> </td><td> </td></tr></table> OFF <table border="1" style="display: inline-table; vertical-align: middle;"><tr><td> </td><td> </td><td> </td><td> </td><td> </td><td> </td><td> </td><td> </td><td> </td><td> </td></tr></table> 1 2 3 4 5 6 7 8 9 10 (Note 1) SW1-7=OFF, SW1-8=ON →Setting air flow. SW1-7=OFF, SW1-8=ON →Indoor fan stop. (Note 2) It is impossible to intake the fresh air.																				
	2	Filter clogging detection	Provided	Not provided																					
	3	Filter sign indication	2,500hr	100hr																					
	4	Air intake (Note 2)	Not effective	Not effective																					
	5	Remote indication switching	Thermostat ON signal indication	Fan output indication																					
	6	Humidifier control	Fan operation at Heating mode	Heat thermostat ON is operating																					
	7	Air flow set in case of Heat thermostat OFF	Low (Note 1)	Extra low (Note 1)																					
	8		Setting air flow (Note 1)	Reset to SW1-7																					
9	Auto restart function	Effective	Not effective																						
10	Power ON/OFF	Effective	Not effective																						
SW2 Capacity code setting	1~4	<table border="1" style="margin: auto;"> <tr> <td>MODELS</td> <td>SW 2</td> </tr> <tr> <td>PKFY-08NAMU-A</td> <td>ON <table border="1" style="display: inline-table; vertical-align: middle;"><tr><td> </td><td> </td><td> </td><td> </td></tr></table> OFF <table border="1" style="display: inline-table; vertical-align: middle;"><tr><td> </td><td> </td><td> </td><td> </td></tr></table> 1 2 3 4</td> </tr> </table>	MODELS	SW 2	PKFY-08NAMU-A	ON <table border="1" style="display: inline-table; vertical-align: middle;"><tr><td> </td><td> </td><td> </td><td> </td></tr></table> OFF <table border="1" style="display: inline-table; vertical-align: middle;"><tr><td> </td><td> </td><td> </td><td> </td></tr></table> 1 2 3 4									<div style="border: 1px solid black; padding: 2px; display: inline-block;">Indoor controller board</div> Set while the unit is off. <At delivery> Set for each capacity.										
MODELS	SW 2																								
PKFY-08NAMU-A	ON <table border="1" style="display: inline-table; vertical-align: middle;"><tr><td> </td><td> </td><td> </td><td> </td></tr></table> OFF <table border="1" style="display: inline-table; vertical-align: middle;"><tr><td> </td><td> </td><td> </td><td> </td></tr></table> 1 2 3 4																								
SW3 Function Selection	1	Heat pump / Cooling only	Cooling only	Heat pump	<div style="border: 1px solid black; padding: 2px; display: inline-block;">Indoor controller board</div> Set while the unit is off. <At delivery> ON <table border="1" style="display: inline-table; vertical-align: middle;"><tr><td> </td><td> </td><td> </td><td> </td><td> </td><td> </td><td> </td><td> </td><td> </td><td> </td></tr></table> OFF <table border="1" style="display: inline-table; vertical-align: middle;"><tr><td> </td><td> </td><td> </td><td> </td><td> </td><td> </td><td> </td><td> </td><td> </td><td> </td></tr></table> 1 2 3 4 5 6 7 8 9 10 (Note 3) At cooling mode, each angle can be used only 1 hour.																				
	2	Capacity save	Available	Not available																					
	3	Vane	Available	Not available																					
	4	Reading change of LEV opening on reversion of after defrosting	Not available	Available																					
	5	Vane horizontal angle	Second setting	First setting																					
	6	Vane cooling limit angle setting (Note 3)	Horizontal angle	Down B, C																					
	7	Indoor linear expansion valve opening	Effective	Not effective																					
	8	Heat 4degrees up	Not effective	Effective																					
9	Target superheat setting temperature	5 degrees	2 degrees																						
10	Target sub cool setting temperature	15 degrees	10 degrees																						

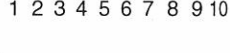
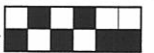
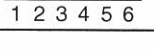
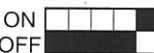
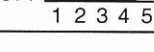
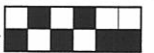
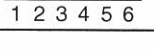
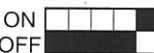
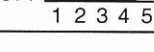
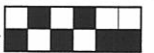
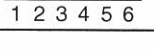
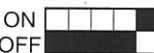
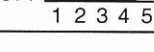

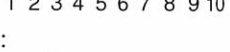

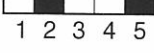
PKFY-12NGMU-A

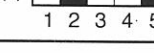
Switch	Pole	Function	Operation by switch		Remarks																																	
			ON	OFF																																		
SW1 Mode Selection	1	Thermistor <intake temperature detection> position	Built-in remote controller	Indoor unit	<div style="border: 1px solid black; padding: 2px; display: inline-block;">Address board</div> <At delivery> ON <table border="1" style="display: inline-table; vertical-align: middle;"><tr><td style="width: 15px; height: 15px;"></td><td></td><td></td><td></td><td></td><td></td><td></td><td></td><td></td><td></td></tr><tr><td style="width: 15px; height: 15px;"></td><td style="background-color: black;"></td><td style="background-color: black;"></td><td style="background-color: black;"></td><td style="background-color: black;"></td><td style="background-color: black;"></td><td style="background-color: black;"></td><td style="background-color: black;"></td><td style="background-color: black;"></td><td style="background-color: black;"></td></tr></table> 1 2 3 4 5 6 7 8 9 10 Note : ※1 At Heating mode, fan operating. ※2 At Heating mode, operating heat thermostat ON. ※3 SW 1-7=OFF, SW 1-8=ON → Setting air flow. SW 1-7=ON, SW 1-8=ON → Indoor fan stop.																																	
	2	Filter clogging detection	Provided	Not provided																																		
	3	Filter cleaning	2,500hr	100hr																																		
	4	Fresh air intake	Effective	Not effective																																		
	5	Remote indication switching	Thermostat ON signal indication	Fan output indication																																		
	6	Humidifier control	Always operated while the heating mode ※1	Operated depends on the condition ※2																																		
	7	Air flow set in case of	Fix to Low ※3	Fix to Extra low ※3																																		
	8	Heat thermostat OFF	Depends on setting remote controller ※3	Depends on SW1-7																																		
9	Auto restart function	Effective	Not effective																																			
10	Power ON/OFF	Effective	Not effective																																			
SW2 Capacity code setting	1~6	<table border="1" style="margin-left: auto; margin-right: auto;"> <tr> <td style="padding: 2px;">MODELS</td> <td style="padding: 2px;">SW 2</td> </tr> <tr> <td style="padding: 2px;">PKFY-12NGMU-A</td> <td style="padding: 2px;"> ON <table border="1" style="display: inline-table; vertical-align: middle;"><tr><td style="width: 15px; height: 15px;"></td><td style="background-color: black;"></td><td style="background-color: black;"></td><td style="background-color: black;"></td><td style="background-color: black;"></td><td style="background-color: black;"></td></tr><tr><td style="width: 15px; height: 15px;"></td><td style="background-color: black;"></td><td style="background-color: black;"></td><td style="background-color: black;"></td><td style="background-color: black;"></td><td style="background-color: black;"></td></tr></table> </td> </tr> <tr> <td></td> <td style="padding: 2px;">1 2 3 4 5 6</td> </tr> </table>		MODELS	SW 2	PKFY-12NGMU-A	ON <table border="1" style="display: inline-table; vertical-align: middle;"><tr><td style="width: 15px; height: 15px;"></td><td style="background-color: black;"></td><td style="background-color: black;"></td><td style="background-color: black;"></td><td style="background-color: black;"></td><td style="background-color: black;"></td></tr><tr><td style="width: 15px; height: 15px;"></td><td style="background-color: black;"></td><td style="background-color: black;"></td><td style="background-color: black;"></td><td style="background-color: black;"></td><td style="background-color: black;"></td></tr></table>														1 2 3 4 5 6	<div style="border: 1px solid black; padding: 2px; display: inline-block;">Indoor controller board</div> Set while the unit is off. <At delivery> Set for each capacity.																
MODELS	SW 2																																					
PKFY-12NGMU-A	ON <table border="1" style="display: inline-table; vertical-align: middle;"><tr><td style="width: 15px; height: 15px;"></td><td style="background-color: black;"></td><td style="background-color: black;"></td><td style="background-color: black;"></td><td style="background-color: black;"></td><td style="background-color: black;"></td></tr><tr><td style="width: 15px; height: 15px;"></td><td style="background-color: black;"></td><td style="background-color: black;"></td><td style="background-color: black;"></td><td style="background-color: black;"></td><td style="background-color: black;"></td></tr></table>																																					
	1 2 3 4 5 6																																					
SW3 Function Selection	1	Heat pump / Cooling only	Cooling only	Heat pump	<div style="border: 1px solid black; padding: 2px; display: inline-block;">Indoor controller board</div> Set while the unit is off. <At delivery> ON <table border="1" style="display: inline-table; vertical-align: middle;"><tr><td style="width: 15px; height: 15px;"></td><td style="background-color: black;"></td><td style="background-color: black;"></td><td style="background-color: black;"></td><td style="background-color: black;"></td><td style="background-color: black;"></td><td style="background-color: black;"></td><td style="background-color: black;"></td><td style="background-color: black;"></td><td style="background-color: black;"></td></tr><tr><td style="width: 15px; height: 15px;"></td><td style="background-color: black;"></td><td style="background-color: black;"></td><td style="background-color: black;"></td><td style="background-color: black;"></td><td style="background-color: black;"></td><td style="background-color: black;"></td><td style="background-color: black;"></td><td style="background-color: black;"></td><td style="background-color: black;"></td></tr></table> 1 2 3 4 5 6 7 8 9 10 Note : ※4 At cooling mode, each angle can be used only 1 hour.																																	
	2	Louver	Available	Not available																																		
	3	Vane	Available	Not available																																		
	4	Vane swing function	Available	Not available																																		
	5	Vane horizontal angle	Second setting	First setting																																		
	6	Vane cooling limit angle setting ※4	Horizontal angle	Down B, C																																		
	7	Indoor linear expansion valve opening	Effective	Not effective																																		
	8	Heat 4degrees up	Not effective	Effective																																		
9	Superheat setting temperature	5 degrees	2 degrees																																			
10	Sub cool setting temperature	15 degrees	10 degrees																																			
SW4 Unit Selection	1~5	<table style="margin-left: auto; margin-right: auto;"> <tr> <td style="padding: 2px;">ON</td> <td style="padding: 2px;"><table border="1" style="display: inline-table; vertical-align: middle;"><tr><td style="width: 15px; height: 15px;"></td><td style="background-color: black;"></td><td style="background-color: black;"></td><td style="background-color: black;"></td><td style="background-color: black;"></td></tr><tr><td style="width: 15px; height: 15px;"></td><td style="background-color: black;"></td><td style="background-color: black;"></td><td style="background-color: black;"></td><td style="background-color: black;"></td></tr></table></td> </tr> <tr> <td style="padding: 2px;">OFF</td> <td style="padding: 2px;">1 2 3 4 5</td> </tr> </table>		ON	<table border="1" style="display: inline-table; vertical-align: middle;"><tr><td style="width: 15px; height: 15px;"></td><td style="background-color: black;"></td><td style="background-color: black;"></td><td style="background-color: black;"></td><td style="background-color: black;"></td></tr><tr><td style="width: 15px; height: 15px;"></td><td style="background-color: black;"></td><td style="background-color: black;"></td><td style="background-color: black;"></td><td style="background-color: black;"></td></tr></table>											OFF	1 2 3 4 5	<div style="border: 1px solid black; padding: 2px; display: inline-block;">Indoor controller board</div> Set while the unit is off. <At delivery> ON <table border="1" style="display: inline-table; vertical-align: middle;"><tr><td style="width: 15px; height: 15px;"></td><td style="background-color: black;"></td><td style="background-color: black;"></td><td style="background-color: black;"></td><td style="background-color: black;"></td></tr><tr><td style="width: 15px; height: 15px;"></td><td style="background-color: black;"></td><td style="background-color: black;"></td><td style="background-color: black;"></td><td style="background-color: black;"></td></tr></table> OFF <table border="1" style="display: inline-table; vertical-align: middle;"><tr><td style="width: 15px; height: 15px;"></td><td style="background-color: black;"></td><td style="background-color: black;"></td><td style="background-color: black;"></td><td style="background-color: black;"></td></tr><tr><td style="width: 15px; height: 15px;"></td><td style="background-color: black;"></td><td style="background-color: black;"></td><td style="background-color: black;"></td><td style="background-color: black;"></td></tr></table> 1 2 3 4 5																				
ON	<table border="1" style="display: inline-table; vertical-align: middle;"><tr><td style="width: 15px; height: 15px;"></td><td style="background-color: black;"></td><td style="background-color: black;"></td><td style="background-color: black;"></td><td style="background-color: black;"></td></tr><tr><td style="width: 15px; height: 15px;"></td><td style="background-color: black;"></td><td style="background-color: black;"></td><td style="background-color: black;"></td><td style="background-color: black;"></td></tr></table>																																					
OFF	1 2 3 4 5																																					

PKFY-20NFMU-A
PKFY-32NFMU-A

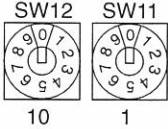
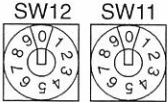
Switch	Pole	Function	Operation by switch		Remarks											
			ON	OFF												
SW1 Mode Selection	1	Thermistor <intake temperature detection> position	Built-in remote controller	Indoor unit	<div style="border: 1px solid black; padding: 2px; display: inline-block;">Address board</div> <At delivery> ON  OFF  1 2 3 4 5 6 7 8 9 10 Note : ※1 At Heating mode, fan operating. ※2 At Heating mode, operating heat thermostat ON. ※3 SW 1-7=OFF, SW 1-8=ON → Setting air flow. SW 1-7=ON, SW 1-8=ON → Indoor fan stop.											
	2	Filter clogging detection	Provided	Not provided												
	3	Filter cleaning	2,500hr	100hr												
	4	Fresh air intake	Effective	Not effective												
	5	Remote indication switching	Thermostat ON signal indication	Fan output indication												
	6	Humidifier control	Always operated while the heating mode ※1	Operated depends on the condition ※2												
	7	Air flow set in case of	Fix to Low ※3	Fix to Extra low ※3												
	8	Heat thermostat OFF	Depends on setting remote controller ※3	Depends on SW1-7												
	9	Auto restart function	Effective	Not effective												
	10	Power ON/OFF	Effective	Not effective												
SW2 Capacity code setting	1~6	<table border="1" style="width: 100%; text-align: center;"> <thead> <tr> <th>MODEL</th> <th>SW 2</th> <th>MODEL</th> <th>SW 2</th> </tr> </thead> <tbody> <tr> <td>PKFY-20NFMU-A</td> <td>ON  OFF </td> <td>PKFY-32NFMU-A</td> <td>ON  OFF </td> </tr> <tr> <td></td> <td>1 2 3 4 5 6</td> <td></td> <td>1 2 3 4 5 6</td> </tr> </tbody> </table>		MODEL	SW 2	MODEL	SW 2	PKFY-20NFMU-A	ON  OFF 	PKFY-32NFMU-A	ON  OFF 		1 2 3 4 5 6		1 2 3 4 5 6	<div style="border: 1px solid black; padding: 2px; display: inline-block;">Indoor controller board</div> Set while the unit is off. <At delivery> Set for each capacity.
MODEL	SW 2	MODEL	SW 2													
PKFY-20NFMU-A	ON  OFF 	PKFY-32NFMU-A	ON  OFF 													
	1 2 3 4 5 6		1 2 3 4 5 6													
SW3 Function Selection	1	Heat pump / Cooling only	Cooling only	Heat pump	<div style="border: 1px solid black; padding: 2px; display: inline-block;">Indoor controller board</div> Set while the unit is off. <At delivery> ON  OFF  1 2 3 4 5 6 7 8 9 10 Note : ※4 At cooling mode, each angle can be used only1 hour. ※5 SW 3-9, 3-10 setting PKFY-20NFMU-A = ON PKFY-32NFMU-A = OFF											
	2	Louver	Available	Not available												
	3	Vane	Available	Not available												
	4	Vane swing function	Available	Not available												
	5	Vane horizontal angle	Second setting	First setting												
	6	Vane cooling limit angle setting ※4	Horizontal angle	Down B, C												
	7	Indoor linear expansion valve opening	Effective	Not effective												
	8	Heat 4degrees up	Not effective	Effective												
	9	Superheat setting temperature	5 degrees	2 degrees												
	10	Sub cool setting temperature	15 degrees	10 degrees												
SW4 Unit Selection	1~5	ON  OFF  1 2 3 4 5		<div style="border: 1px solid black; padding: 2px; display: inline-block;">Indoor controller board</div> Set while the unit is off. <At delivery> ON  OFF  1 2 3 4 5												

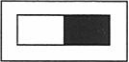
PKFY-08NAMU-A
 PKFY-12NGMU-A
 PKFY-20NFMU-A
 PKFY-32NFMU-A

Switch	Pole	Operation by switch	Remarks
SW11 1st digit address setting SW12 2nd digit address setting	Rotary switch	 <p>Address setting should be done when M-NET Remote controller is being used.</p>	<p>Address board</p> <p>Address can be set while the unit is stopped.</p> <p><At delivery></p> 
SW14 Connection No. setting	Rotary switch	 <p>This is the switch to be used when the indoor unit is operated with R2 series outdoor unit as a set.</p>	<p>Address board</p> <p><At delivery></p> <p>SW14</p> 
SW5 Voltage Selection	2	<p>220V (208V) 240V (230V)</p>  <p>If the unit is used at the 230V area, set the voltage to 230V. If the unit is used at the 208V, set the voltage to 208V.</p>	<p>Address board</p> <p><At delivery></p> <p>220V (208V) 240V (230V)</p> 

PKFY-08NAMU-A

Be careful on removing heavy parts.

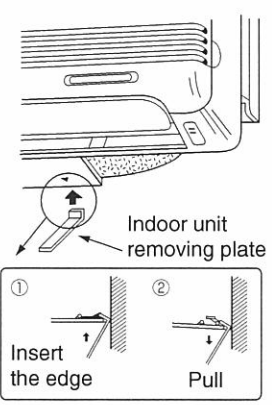
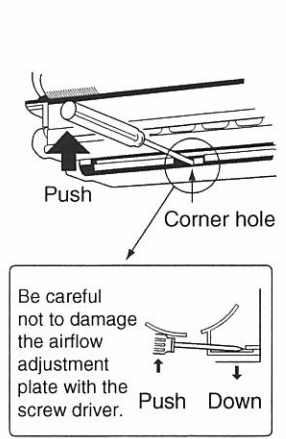
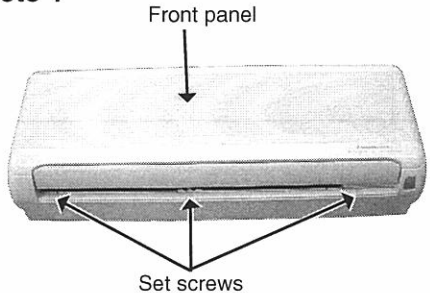
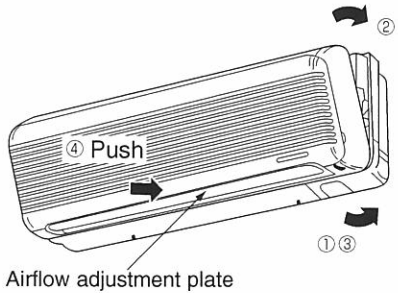
OPERATING PROCEDURE	PHOTOS&ILLUSTRATIONS
<p>1. REMOVING THE LOWER SIDE OF THE INDOOR UNIT FROM THE INSTALLATION PLATE</p> <p>When there is removing plate</p> <ol style="list-style-type: none"> (1) Remove the corner box at right lower side of the indoor unit. (2) Insert the removing plate at the back side of the corner box to remove the indoor unit. (3) Remove the hook by pulling the lower side of the indoor unit down as shown in the figure 1. <p>When there is no removing plate or it can not be used for some reason.</p> <ol style="list-style-type: none"> (1) Remove the front panel. (2) Insert the screw driver to the corner hole at both left and right side as shown in the figure 2. (3) Push it up then, pull down the lower side of indoor unit and remove the hook. 	<p>Figure 1</p>  <p>Figure 2</p>  <p>Be careful not to damage the airflow adjustment plate with the screw driver.</p>
<p>2. REMOVING THE FRONT PANEL</p> <p>※ Before removing the front panel, leave the open space at upper side of air flow adjustment plate approximately 2 to 3 cm.</p> <ol style="list-style-type: none"> (1) Remove the screw caps then remove the set screws. (Refer to the photo 1) (2) Remove the left side of the front panel, then right side. (3) After removing the lower side of the front panel a little, remove it as pulling the upper side toward you. <p>※ Please pay attention to the nozzle assemble.</p> <p>INSTALLING THE FRONT PANEL</p> <ol style="list-style-type: none"> (1) Insert the lower side of the front panel under the air adjustment plate. (2) Set the upper side of the front panel. (3) Set the lower side of the front panel then fix it with the screws. (4) Press the area indicated as arrow sign and set it to the air conditioner unit. 	<p>Photo 1</p>  <p>Figure 3</p> 

OPERATING PROCEDURE

3. REMOVING THE INDOOR MICRO CONTROLLER BOARD AND INDOOR POWER BOARD

- (1) Remove the front panel. (Refer to 2)
- (2) Remove the electrical box cover (screw 4×10).
(Refer to the photo 2)

INDOOR MICRO CONTROLLER BOARD

- (1) Disconnect the following connectors on the indoor micro controller board.
(connector in front of)
 - CN60, CN5V, CN34, CN29, CN21
 - CN42, CN81, CN3A, CN20
- (2) Pull out the indoor micro controller board toward you, then disconnect the rest of connectors.
 - CN53M, CN35M (See the photo 3)

INDOOR POWER BOARD

- (1) Disconnect the following connectors on the indoor power board.
 - FAN, CN53P, CN35P, CN2M, CND
- (2) Remove the screws of the indoor power board, then pull out the indoor power board toward you. (See the photo 3)

PHOTOS&ILLUSTRATIONS

Photo 2

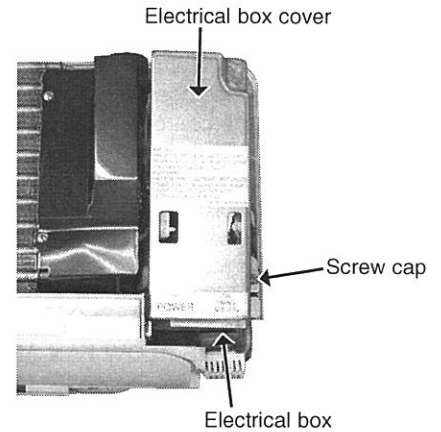
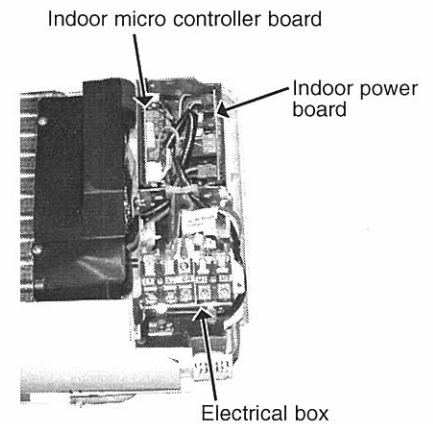

Photo 3



4. REMOVING THE ELECTRICAL BOX

- (1) Remove the front panel. (Refer to 2)
- (2) Remove the electrical box cover.
- (3) Pull the nozzle assembly toward you as opening the catch of the nozzle assembly.
- (4) Disconnect the indoor/outdoor connector.
- (5) Disconnect the following connector on the indoor micro controller board. (See the photo 4)
 - CN60, CN5V, CN34, CN29, CN21, CN20, CN3A
- (6) Disconnect the following connector on the indoor power board. (See the photo 4)
 - FAN, CN2M, CND
- (7) Disconnect the ground wire.
- (8) Pull the disconnected lead wire out from the electrical box.
- (9) Push up the upper fixture catch to remove the box, then pull the lower fixture and remove it from the box fixture.

Photo 4

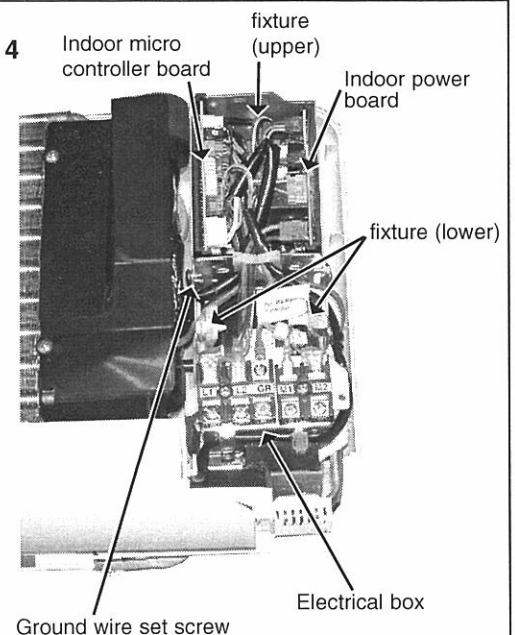

OPERATING PROCEDURE

PHOTOS&ILLUSTRATIONS

5. REMOVING THE NOZZLE ASSEMBLY

- (1) Remove the front panel (Refer to 2).
- (2) Remove the electrical box cover.
- (3) Disconnect the connector (CN5V) on the indoor micro controller board.
- (4) After unhook the right side of the corner box, press the upper left side and remove the corner box.
- (5) Remove the nozzle assemble from the fixture. (See the photo 5)
- (6) Remove the drain hose.

Photo 5

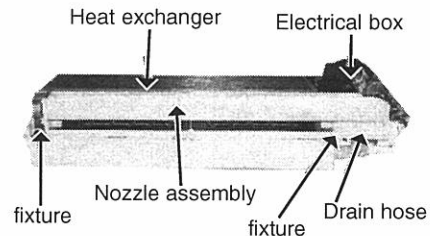

6. REMOVING THE LINE FLOW FAN AND THE FAN MOTOR

- (1) Remove the front panel. (Refer to 2)
- (2) Remove the nozzle assembly. (Refer to 5)
- (3) Remove the electrical parts box.
- (4) Remove the fixture while pressing the right side of motor fixture catch. (See the photo 6)
- (5) Remove the left side of the motor fixture.
- (6) Loosen the screw which fixes the line flow fan to the fan motor, then remove the fan motor by sliding it to the right side. (See the photo 6)
- (7) Pull the left-hand side of the heat exchanger toward you. (See the photo 7)
- (8) Remove the line flow fan.

Photo 6

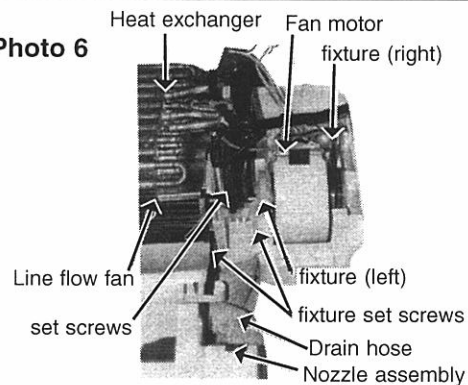
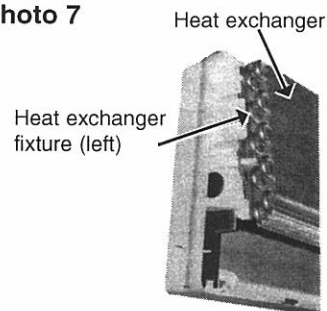

Photo 7



7. REMOVING THE VANE MOTOR

- (1) Remove the front panel.
- (2) Remove the screw of the electrical parts box cover, and remove the cover.
- (3) Remove the screw of the vane motor, and remove the motor from the shaft.
- (4) Disconnect the vane motor connector (CN5V) on the indoor controller board.

Photo 8

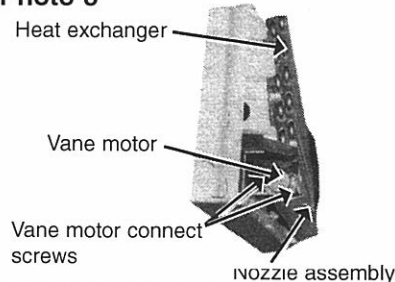

8. REMOVING THE LIQUID PIPE THERMISTOR AND GAS PIPE THERMISTOR

- (1) Remove the front panel. (Refer to 2)
- (2) Remove the electrical box cover.
- (3) Remove the pipe cover.
- (4) Cut the wiring fixed band.
- (5) Remove the liquid pipe thermistor and gas pipe thermistor. (See the photo 9)
- (6) Disconnect the connector (CN29) (CN21) on the indoor micro controller board.

Photo 9

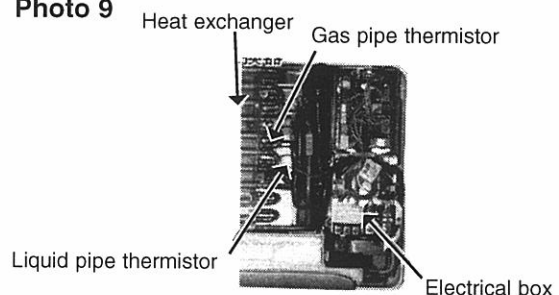

PKFY-12NGMU-A

OPERATION PROCEDURE

PHOTOS & ILLUSTRATION

1. REMOVE THE LOWER SIDE OF THE INDOOR UNIT FROM THE INSTALLATION PLATE

- (1) Remove the left / right corner box of the indoor unit.
- (2) Hold and pull down the lower and both ends of the indoor unit, and remove the ▼ section from the square hole.
(Refer to the figure 2.1)
Or remove the front panel and push the ▼ section down by using allen wrench ,etc. from the front side.
(Refer to the figure 2.2).
- (3) Unhook the top of the indoor unit from the back plate catch.

(Figure 2.2)

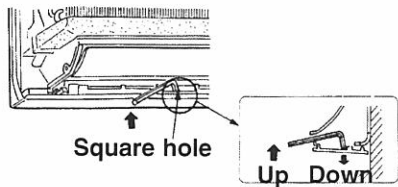

(Figure 1)

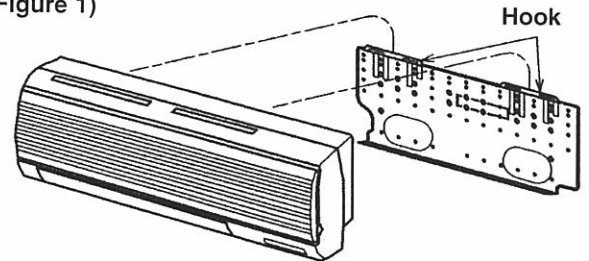

(Figure2.1)

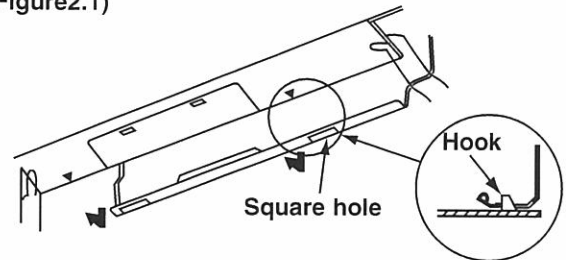

2. REMOVING THE FRONT PANEL

- (1) Open the front grille.
- (2) Remove the terminal block cover with a screw.
- (3) Remove the screw 3caps then remove the set 3screws.
- (4) After removing the lower side of the front panel a little, remove it as pulling toward upper.

(Figure 3)

Terminal block cover

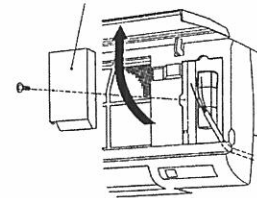

(Photo 1)

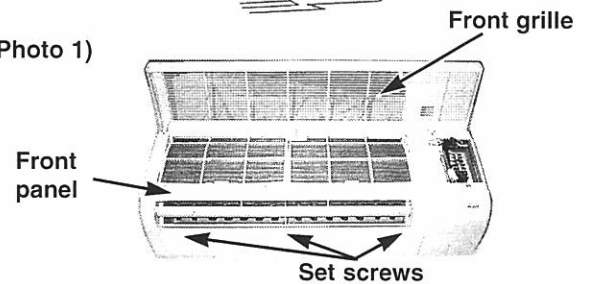

3. REMOVING THE INDOOR CONTROLLER BOARD

- (1) Remove the terminal block cover.
- (2) Remove the front panel. (see the photo 1)
- (3) Remove the electrical parts box(2screws).
- (4) Remove the electrical parts box cover(1screw).
- (5) Disconnect the connector on the indoor controller board and remove the controller board by Pulling up the hook of the controller case.

※ To smooth work, hang the side hooks of the electrical parts box on the hook of the motor cover.
(see the photo 3)

(Photo 2)

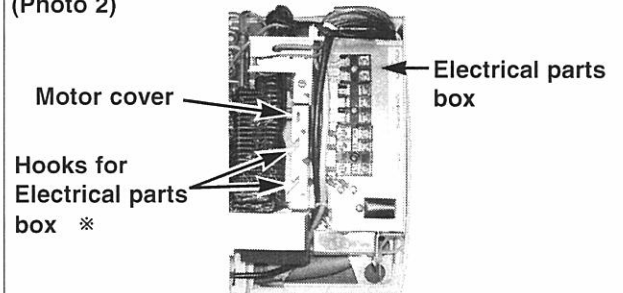

(Photo 3)

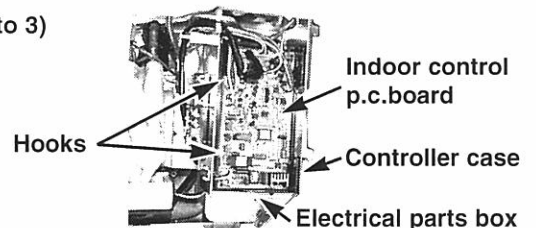

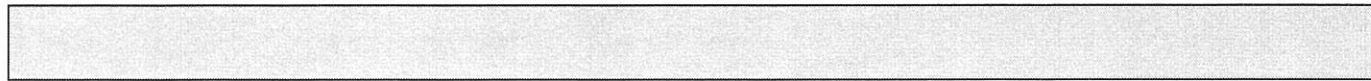

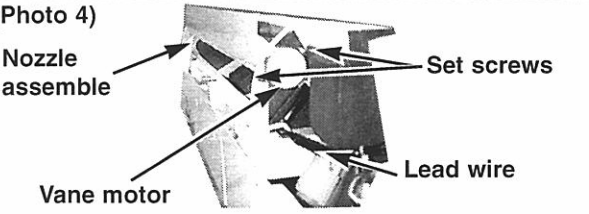
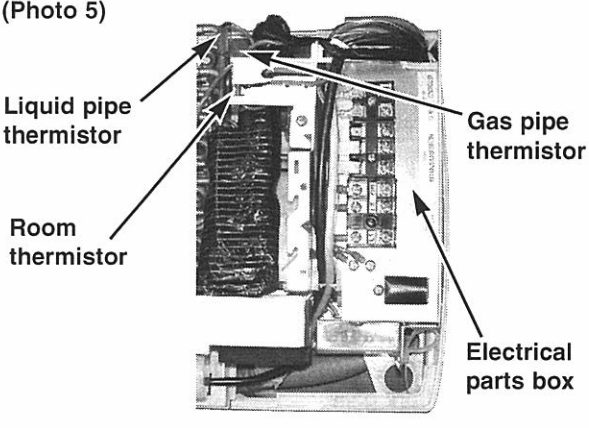
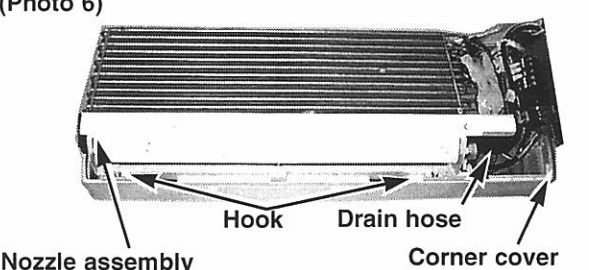
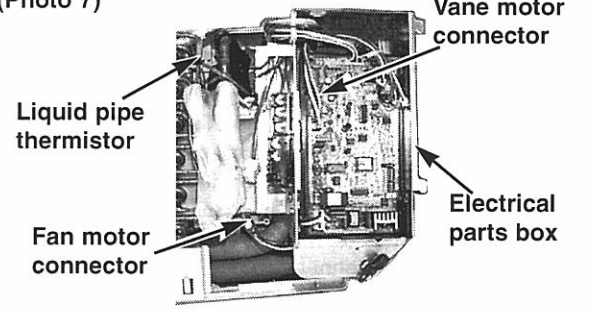
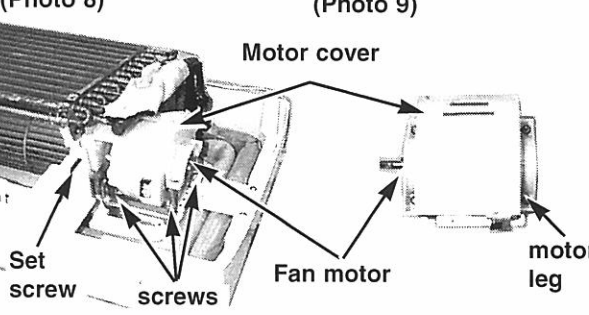
OPERATION PROCEDURE	PHOTOS & ILLUSTRATION
<p>4. REMOVING THE VANE MOTOR</p> <p>(1) Disconnect the connector CN6V on the indoor controller board.</p> <p>(2) Remove the 2screws of the vane motor, disconnect the lead wire and remove the vane motor from the shaft.</p>	<p>(Photo 4)</p>  <p>Nozzle assemble</p> <p>Set screws</p> <p>Vane motor</p> <p>Lead wire</p>
<p>5. REMOVING THE THERMISTOR</p> <p>(1) Removing the room thermistor TH21.</p> <p>① Disconnect the connector CN20<red> on the indoor controller board.</p> <p>② Remove the room thermistor from the holder.</p> <p>(2) Removing the liquid pipe thermistor TH22.</p> <p>① Disconnect the connector CN21<white> on indoor controller board.</p> <p>② Remove the liquid pipe thermistor with set to the pipe.</p> <p>(3) Removing the gas pipe thermistor TH23.</p> <p>① Disconnect the connector CN29<black> on indoor controller board.</p> <p>② Remove the gas pipe thermistor with set to the pipe.</p>	<p>(Photo 5)</p>  <p>Liquid pipe thermistor</p> <p>Room thermistor</p> <p>Gas pipe thermistor</p> <p>Electrical parts box</p>
<p>6. REMOVING THE NOZZLE ASSEMBLY</p> <p>(1) Disconnect the connector CN6V on the indoor controller board.</p> <p>(2) Disconnect the lead wire of the vane motor.</p> <p>(3) Remove the corner cover.</p> <p>(4) Pull the drain hose out from the nozzle assembly.</p> <p>(5) Unhook the hook of the lower nozzle assembly and pull the nozzle assembly toward you, then remove the nozzle assembly by sliding it down.</p>	<p>(Photo 6)</p>  <p>Nozzle assembly</p> <p>Hook</p> <p>Drain hose</p> <p>Corner cover</p>
<p>7. REMOVING THE ELECTRICAL PARTS BOX</p> <p>(1) Remove the terminal block cover.</p> <p>(2) Remove the front panel.(see the photo 1)</p> <p>(3) Disconnect the vane motor connector.</p> <p>(4) Disconnect the fan motor connector from the fan motor.</p> <p>(5) Remove the liquid / gas pipe thermistor.(see the photo 5)</p> <p>(6) Disconnect the linear expansion valve connector.</p> <p>(7) Remove the electrical parts box (2screws).</p>	<p>(Photo 7)</p>  <p>Liquid pipe thermistor</p> <p>Fan motor connector</p> <p>Vane motor connector</p> <p>Electrical parts box</p>
<p>8. REMOVING THE FAN MOTOR</p> <p>(1) Remove the terminal block cover.</p> <p>(2) Remove the front panel.(see the photo 1)</p> <p>(3) Remove the electrical parts box.(see the photo 7)</p> <p>(4) Remove the nozzle assembly.(see the photo 6)</p> <p>(5) Remove the fan motor leg fixing 3screws.</p> <p>(6) Unscrew the set screws using by allen wrench and remove it by sliding the fan motor to right.</p> <p>(7) Remove the 4screws and remove the motor cover from the fan motor leg.</p>	<p>(Photo 8) (Photo 9)</p>  <p>Set screw</p> <p>screws</p> <p>Motor cover</p> <p>Fan motor</p> <p>motor leg</p>

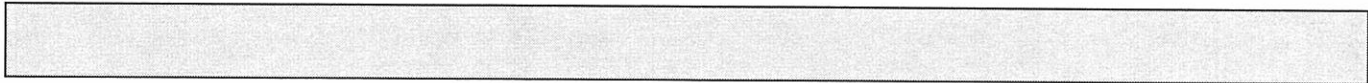

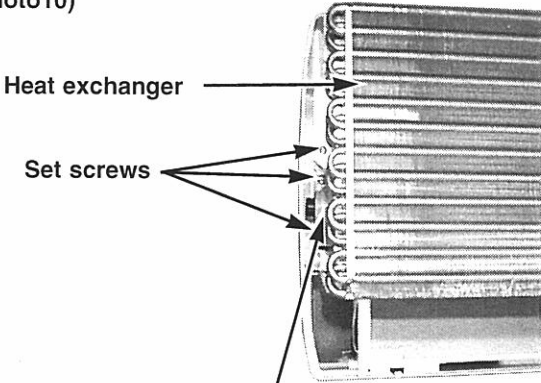
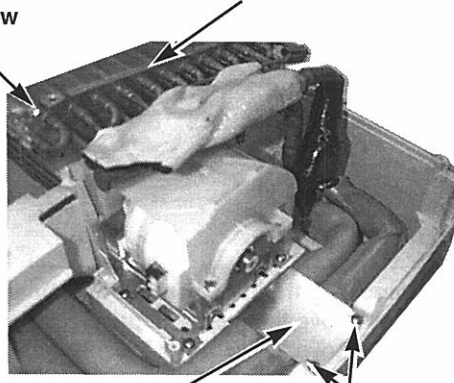
OPERATION PROCEDURE	PHOTOS & ILLUSTRATION
<p>9. REMOVING THE LINE FLOW FAN</p> <ol style="list-style-type: none">(1) Remove the terminal block cover.(2) Remove the front panel.(see the photo 1)(3) Remove the electrical parts box.(see the photo 7)(4) Remove the nozzle assembly.(see the photo 6)(5) Remove the fan motor.(see the photo 8)(6) Remove the pipe fixture with 2screws.(see the photo11)(7) Remove the left / right screws of the heat exchanger and pull the left-hand side up.(8) Remove the 2screws by sliding it toward you remove the fixture(fixing bearing). <p>* The fan motor is removable first , when the fan removing is hard.</p> <p>* When resetting the fan to the fan motor. Locate and fix the shaft after installing the fan.</p>	<p>(Photo10)</p>  <p>Heat exchanger</p> <p>Set screws</p> <p>Fixture(fixing bearing)</p>
<p>10. REMOVING THE HEAT EXCHANGER</p> <ol style="list-style-type: none">(1) Remove the terminal block cover.(2) Remove the front panel.(see the photo 1)(3) Remove the electrical parts box.(see the photo 7)(4) Remove the corner box.(5) Remove the nozzle assemble.(see the photo 6)(6) Remove the 2screws and the pipe fixture.(7) Remove the 2screws and heat exchanger.	<p>(Photo 11)</p>  <p>Heat exchanger</p> <p>Set screw</p> <p>Pipe fixture</p> <p>Set screws</p>

PKFY-32NFMU-A

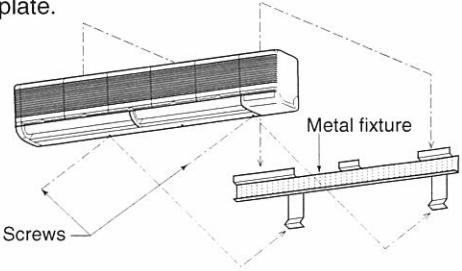
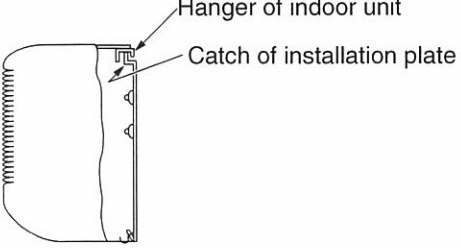
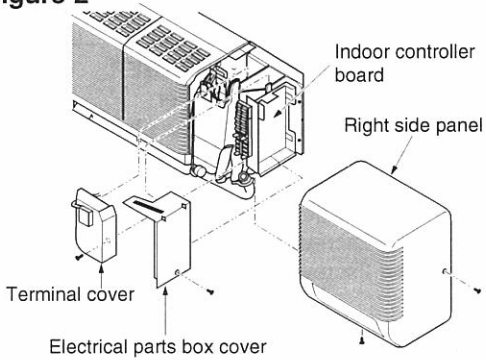
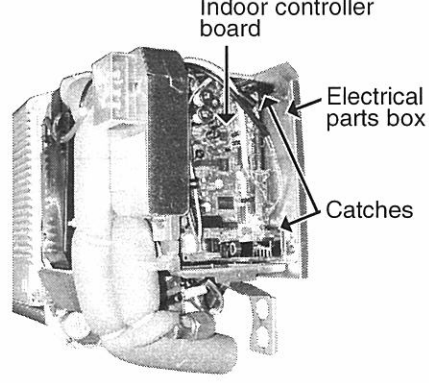
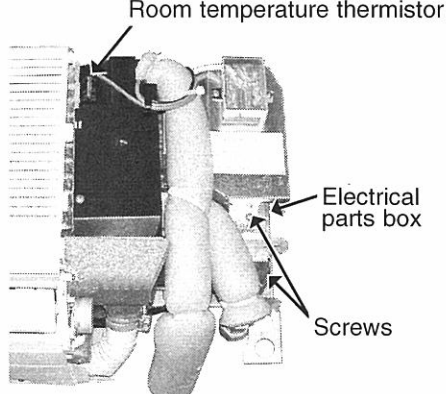
OPERATING PROCEDURE	PHOTOS & ILLUSTRATION
<p>1. Removing the lower side of the indoor unit from the installation plate</p> <p>(1) Remove the 2 screws. Hang the indoor unit hangers to the catches on the installation plate.</p> 	<p>Figure 1</p> 
<p>2. Removing the right side panel</p> <p>(1) Remove the 2 screws of the right side panel: one on the bottom and the other on the upper right-hand side. (2) Sliding the right side panel to the right, pull it out toward you.</p>	<p>Figure 2</p> 
<p>3. Removing the indoor controller board</p> <p>(1) Remove the right side panel. (2) Remove the screw of the electrical parts box cover, and remove the cover. (3) Disconnect the connectors on the indoor controller board. (4) To unhook the catches on the right-hand side of the indoor controller board, pull the left-hand side toward you and lift up the cover to the right. Then the indoor controller board can be removed.</p>	<p>Photo 1</p> 
<p>4. Removing the electrical parts box</p> <p>(1) Remove the right side panel. (2) Remove the screw of the electrical parts box cover and controller cover, and remove each the cover. (3) Disconnect the vane motor, the linear expansion valve, the room temperature thermistor, the liquid pipe temperature thermistor and the gas pipe temperature thermistor connector on the indoor controller board. (4) Remove the 2 screws of the electrical parts box. (5) Disconnect the connector of the fan motor lead wire. (Fan motor side) (6) Remove the electrical parts box.</p>	<p>Photo 2</p> 

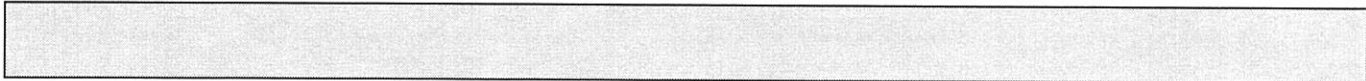

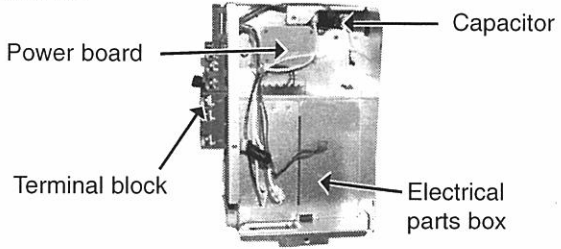
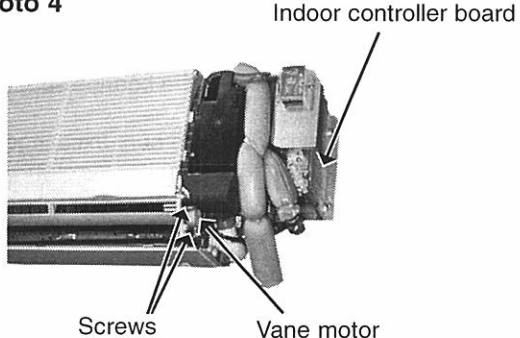
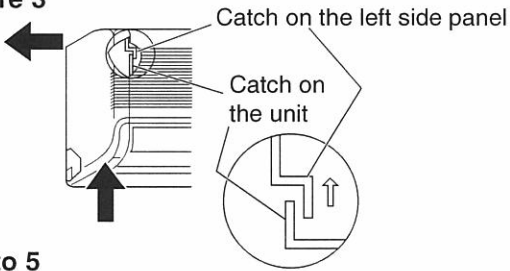
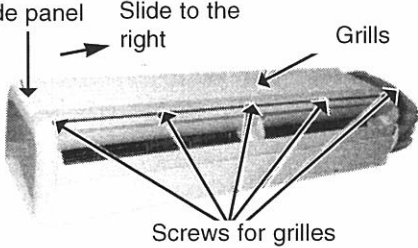
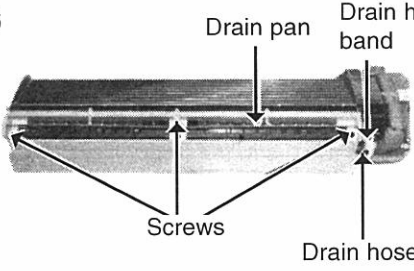
OPERATING PROCEDURE	PHOTOS & ILLUSTRATION
<p>(7) Remove the indoor controller board case. Then the Power board and the capacitor can be serviced.</p>	<p>Photo 3</p>  <p>Power board</p> <p>Terminal block</p> <p>Capacitor</p> <p>Electrical parts box</p>
<p>5. Removing the vane motor</p> <ol style="list-style-type: none">(1) Remove the right side panel.(2) Remove the screw of the electrical parts box cover, and remove the terminal cover.(3) Remove the 2 screws of the vane motor, and remove the motor from the shaft.(4) Disconnect the vane motor connector on the indoor controller board.	<p>Photo 4</p>  <p>Indoor controller board</p> <p>Screws</p> <p>Vane motor</p>
<p>6. Removing the intake grilles</p> <ol style="list-style-type: none">(1) Remove the right side panel.(2) To remove the left side panel, remove the screw on the bottom and the screw on the upper left-hand side. (See Figure 3.)<ol style="list-style-type: none">1. Press up this side of the left side panel to unhook the catch on the panel from the catch on the unit.2. Slide the left side panel to the left to remove the panel. <p>Note: Fix the unit to the metal fixture securely</p> <ol style="list-style-type: none">(3) Remove the air filters.(4) Hold and press the center cover to remove.(5) Remove the screws of the grilles.(6) Pull the lower side of the grille toward you and slide the upper to the right to remove the grilles.	<p>Figure 3</p>  <p>Catch on the left side panel</p> <p>Catch on the unit</p> <p>Photo 5</p>  <p>Left side panel</p> <p>Slide to the right</p> <p>Grilles</p> <p>Screws for grilles</p>
<p>7. Removing the drain pan</p> <ol style="list-style-type: none">(1) Remove the left and right side panels.(2) Remove the grilles.(3) Remove the electrical parts box cover.(4) Loosen the drain hose band to remove.(5) Remove the 3 screws of the drain pan, and slide the drain pan toward you to remove.	<p>Photo 6</p>  <p>Drain pan</p> <p>Drain hose band</p> <p>Screws</p> <p>Drain hose</p>

OPERATING PROCEDURE

8. Removing the lineflow fan and the fan motor

- (1) Remove the left and right side panels.
- (2) Remove the grilles.
- (3) Remove the electrical parts box.
- (4) Remove the drain pan.
- (5) Loosen the screw that fixes the lineflow fan to the fan motor. (See Photo 7.)
- (6) Remove the 4 screws of the motor fixture, and remove the fan motor and the motor fixture at a time (See Photo 8.)
- (7) Remove the screws of the left and right motor supports, and remove the motor supports and the fan motor. (See Photo 9.)
- (8) Remove the screw of the center support, and remove the support. (See Photo 10.)
- (9) Remove the 2 screws on the left and right sides of the heat exchanger, and pull the bearing support toward you. (See Photo 11.)
- (10) Pull the left-hand side of the heat exchanger toward you, and remove the lineflow fan.

Photo 11

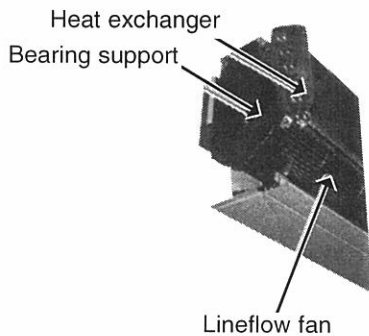

PHOTOS

Photo 7

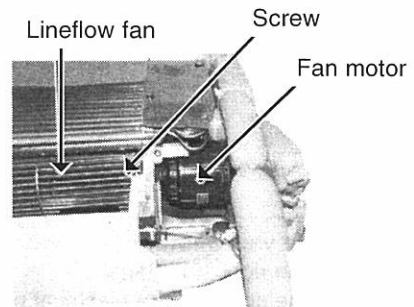

Photo 8

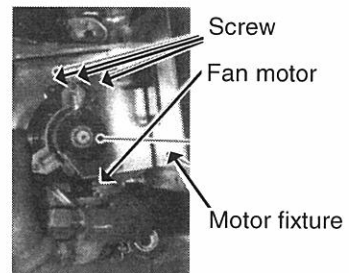

Photo 9

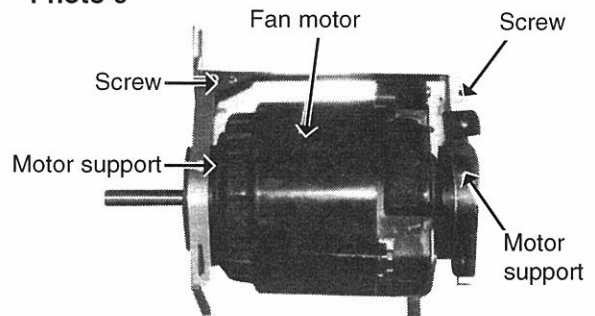
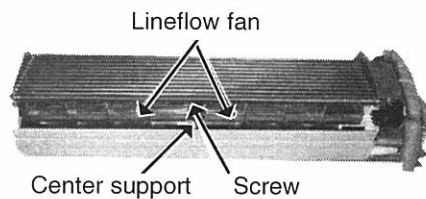

Photo 10



11

PARTS LIST

PANEL PARTS PKFY-08NAMU-A

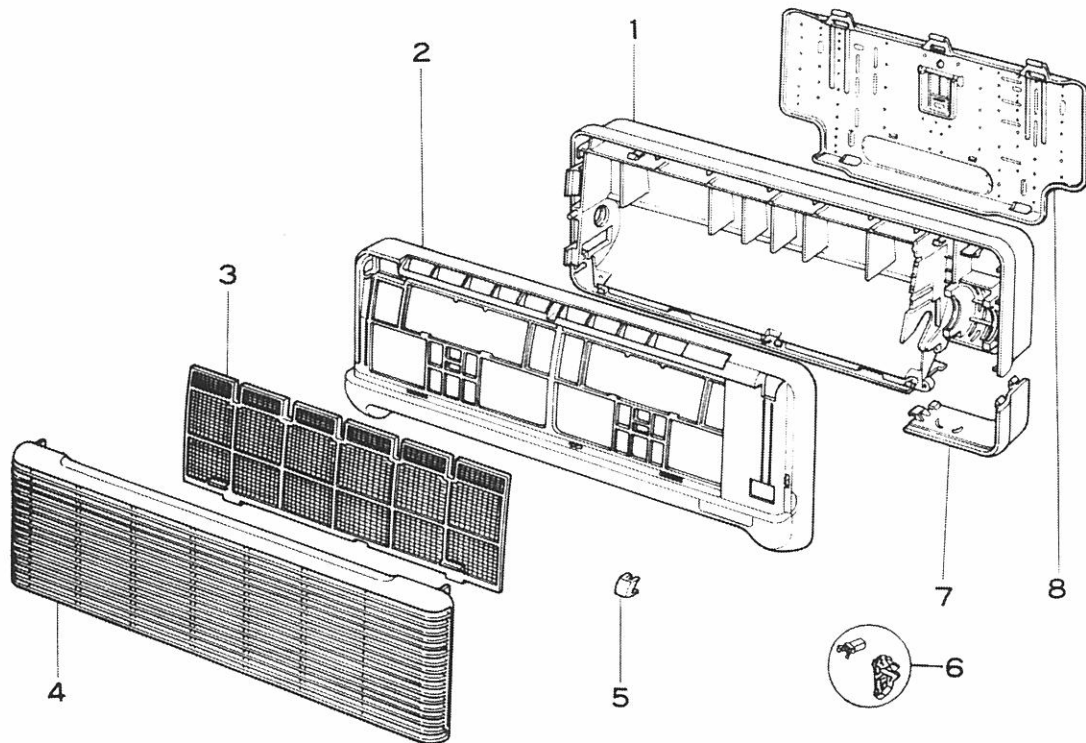

No.	Parts No.	Parts Name	Specifications	Q'ty / set	Remarks (Drawing No.)	Wiring Diagram Symbol	Recom- mended Q'ty	Price	
				PKFY-08NAMU-A				Unit	Amount
1	R01 22A 635	BOX		1					
2	R01 22A 651	FRONT PANEL		1					
3	R01 22A 500	AIR FILTER		1					
4	R01 22A 691	INTAKE GRILLE		1					
5	R01 22A 096	SCREW CAP		1	3PCS/SET				
6	R01 22A 054	GRILLE CATCH		1					
7	T7W A00 658	CORNER BOX		1					
8	R01 22A 808	BACK PLATE		1					

ELECTRICAL PARTS PKFY-08NAMU-A

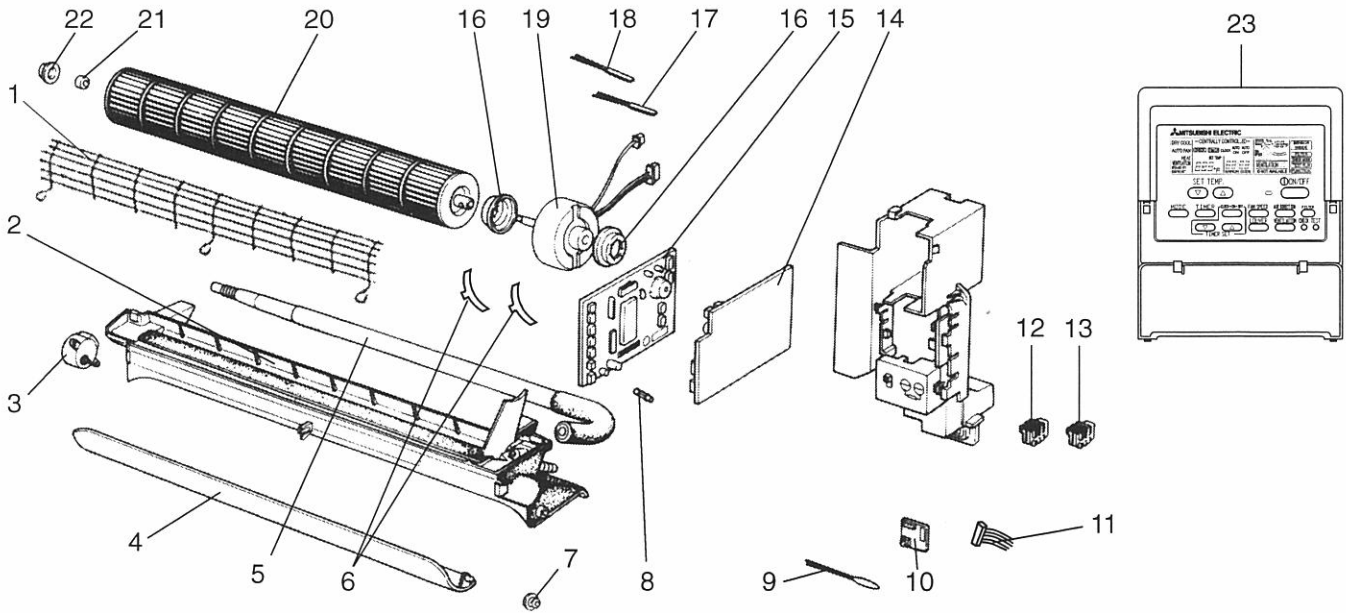

No.	Parts No.	Parts Name	Specifications	Q'ty / set	Remarks (Drawing No.)	Wiring Diagram Symbol	Recom- mended Q'ty	Price	
				PKFY- 08NAMU-A				Unit	Amount
1	T7W B00 675	FAN GUARD		1					
2	R01 22A 530	NOZZLE		1					
3	R01 22A 223	VANE MOTOR		1		MV			
4	R01 22A 002	AUTO VANE		1					
5	R01 22A 527	DRAIN HOSE		1					
6	R01 22A 126	MOTOR BAND	SET (LEFT, RIGHT)	1					
7	R01 07Y 092	VANE SLEEVE		1					
8	T7W 410 239	FUSE	250V 6A	1		FUSE			
9	T7W E12 202	ROOM TEMPERATURE THERMISTOR		1		TH21			
10	T7W E00 294	ADDRESS BOARD		1		A.B			
11	T7W E00 304	ADDRESS CABLE		1					
12	T7W E18 716	TERMINAL BLOCK	3P (L1, L2, GR)	1		TB2			
13	T7W E19 716	TERMINAL BLOCK	2P (M1, M2)	1		TB5			
14	T7W E05 313	POWER BOARD		1		P.B			
15	T7W E29 310	INDOOR CONTROLLER BOARD		1		M.B			
16	R01 22A 105	RUBBER MOUNT		2					
17	R01 E38 202	PIPE TEMPERATURE THERMISTOR	GAS	1		TH23			
18	T7W E06 202	PIPE TEMPERATURE THERMISTOR	LIQUID	1		TH22			
19	T7W E18 762	FAN MOTOR	PS4N8-KA	1		MF			
20	R01 22A 114	LINE FLOW FAN		1					
21	R01 005 103	SLEEVE BEARING		1					
22	R01 22A 102	BEARING MOUNT		1					
23	—	REMOTE CONTROLLER	PAR-20MAU	1		R.B			

↑ This REMOTE CONTROLLER is made by AIR-CONDITIONING & REFRIGERATION SYSTEMS WORKS., MITSUBISHI ELECTRIC CORPORATION.

HEAT EXCHANGER PARTS
PKFY-08NAMU-A

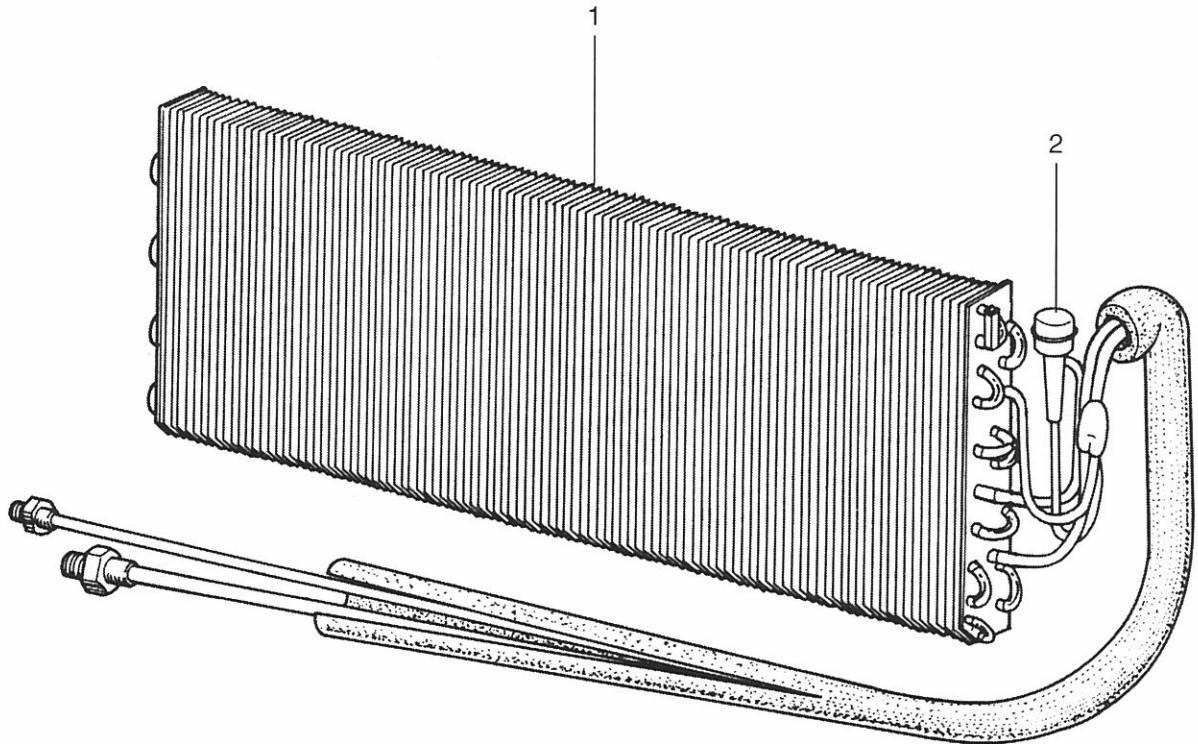

No.	Parts No.	Parts Name	Specifications	Q'ty / set	Remarks (Drawing No.)	Wiring Diagram Symbol	Recom- mended Q'ty	Price	
				PKFY- 08NAMU-A				Unit	Amount
1	T7W E84 480	HEAT EXCHANGER	With connection pipe	1					
2	R01 E27 401	LINEAR EXPANSION VALVE		1		LEV			

**STRUCTURAL PARTS
PKFY-12NGMU-A**

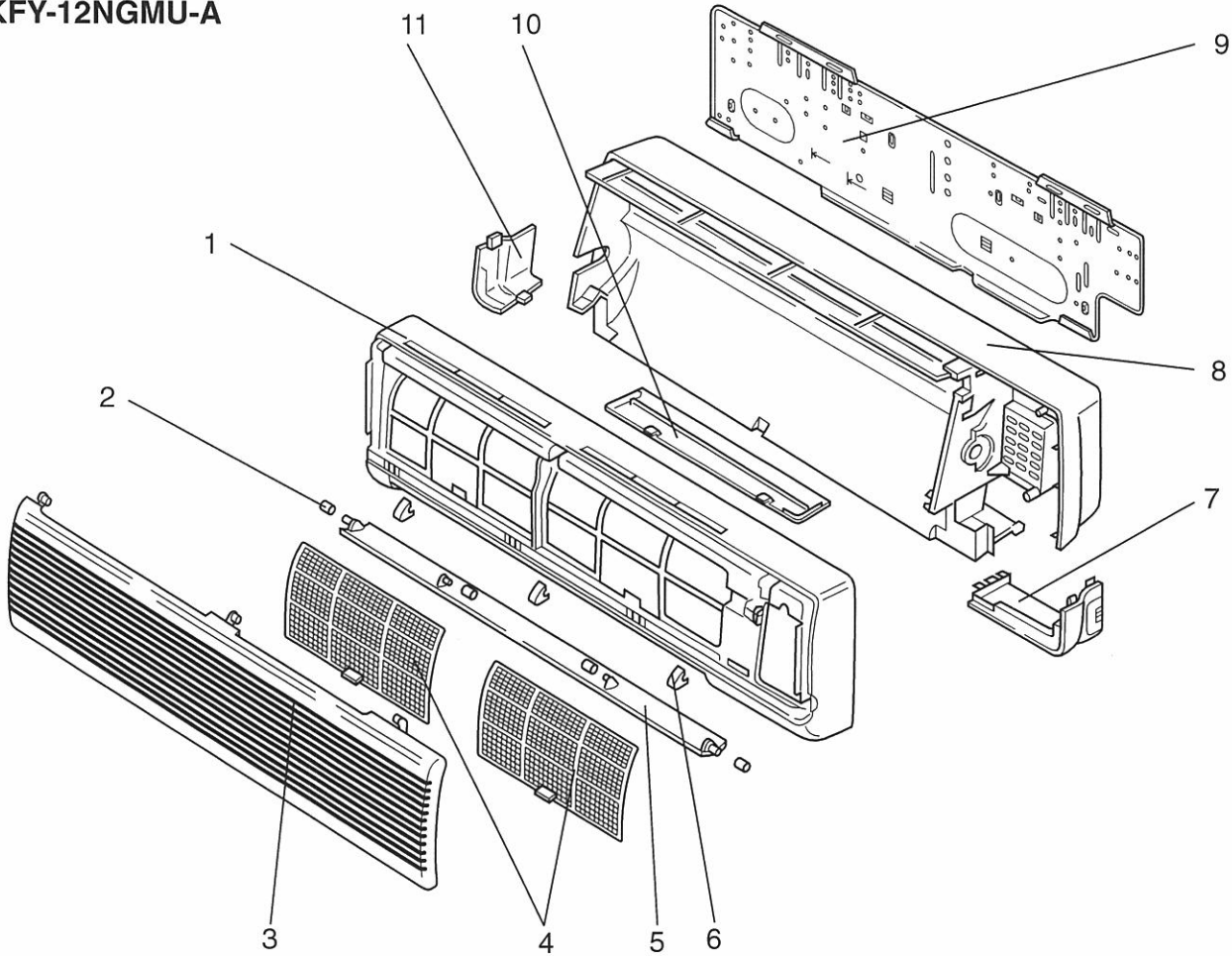

No.	Parts No.	Parts Name	Specifications	PKFY-12NGMU-A	Remarks (Drawing No.)	Wiring Diagram Symbol	Recom- mended Q'ty	Price	
								Unit	Amount
1	R01 07Y 651	FRONT PANEL		1					
2	R01 07Y 092	VANE SLEEVE		1					
3	R01 07Y 691	FRONT GRILLE		1					
4	R01 A16 500	AIR FILTER		2					
5	R01 07Y 002	AUTO VANE		1					
6	R01 07Y 096	SCREW CAP		3					
7	R01 09Y 658	CORNER COVER		1					
8	R01 07Y 635	BOX ASSEMBLY		1					
9	R01 07Y 808	BACK PLATE		1					
10	R01 07Y 623	UNDER COVER		1					
11	R01 07Y 658	CORNER COVER		1					

ELECTRICAL PARTS PKFY-12NGMU-A

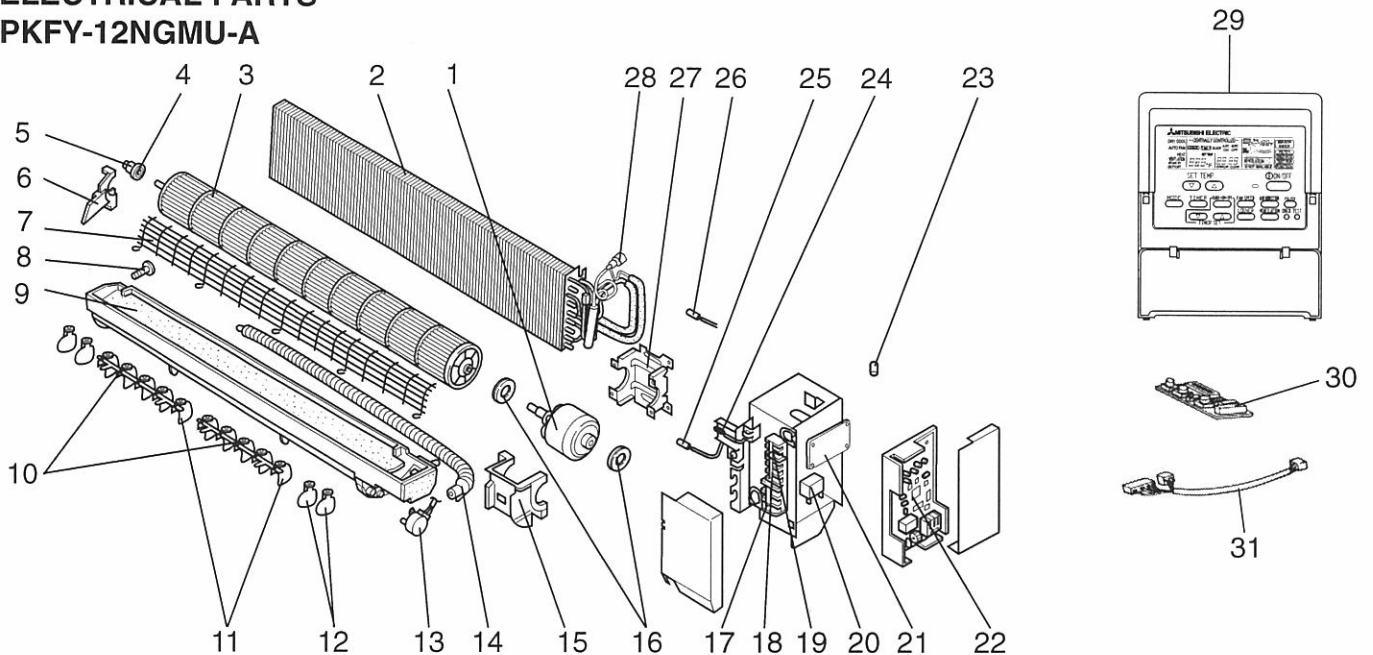

No.	Parts No.	Parts Name	Specifications	PKFY-	Remarks (Drawing No.)	Wiring Diagram Symbol	Recom- mended Qty	Price	
				12NGMU-A				Unit	Amount
1	T7W E19 762	FAN MOTOR	PM4N30-KA	1		MF			
2	R01 E25 480	HEAT EXCHANGER		1					
3	R01 07Y 114	LINE FLOW FAN		1					
4	R01 005 103	SLEEVE BEARING		1					
5	R01 07Y 102	BEARING MOUNT		1					
6	R01 07Y 106	BEARING SUPPORT		1					
7	T7W A00 675	FAN GUARD		1					
8	R01 07Y 524	DRAIN PLUG		1					
9	R01 07Y 530	NOZZLE ASSY		1					
10	R01 07Y 059	ARM		2					
11	R01 07Y 038	GUIDE VANE		10					
12	R01 09Y 038	GUIDE VANE		4					
13	T7W E04 223	VANE MOTOR		1		MV			
14	R01 07Y 527	DRAIN HOSE		1					
15	R01 07Y 135	MOTOR COVER		1					
16	R01 07Y 105	RUBBER MOUNT		2					
17	T7W E11 716	TERMINAL BLOCK	3P(L1, L2, GR)	1		TB2			
18	T7W E17 716	TERMINAL BLOCK	3P(M1,M2,S)	1		TB5			
19	R01 556 246	TERMINAL BLOCK	2P(1,2)	1		TB15			
20	T7W E11 255	RUN CAPACITOR	2.0 μ F 440V	1		C			
21	R01 E02 313	POWER BOARD		1		P.B			
22	T7W E28 310	CONTROLLER BOARD		1		I.B			
23	T7W 410 239	FUSE	250V 6A	1		FUSE			
24	R01 E26 202	ROOM THERMISTOR		1		TH21			
25	R01 E28 202	LIQUID PIPE THERMISTOR		1		TH22			
26	T7W E25 202	GAS PIPE THERMISTOR		1		TH23			
27	R01 07Y 130	MOTOR SUPPORT		1					
28	R01 E27 401	LINEAR EXPANSION VALVE		1		LEV			
29	—	REMOTE CONTROLLER	PAR-20MAU	1					
30	T7W E00 294	ADDRESS BOARD		1		A.B			
31	R01 85Y 304	ADDRESS CABLE		1					

This REMOTE CONTROLLER is made by AIR-CONDITIONING & REFRIGERATION SYSTEMS WORKS., MITSUBISHI ELECTRIC CORPORATION.

ELECTRICAL PARTS
PKFY-20NFMU-A PKFY-32NFMU-A

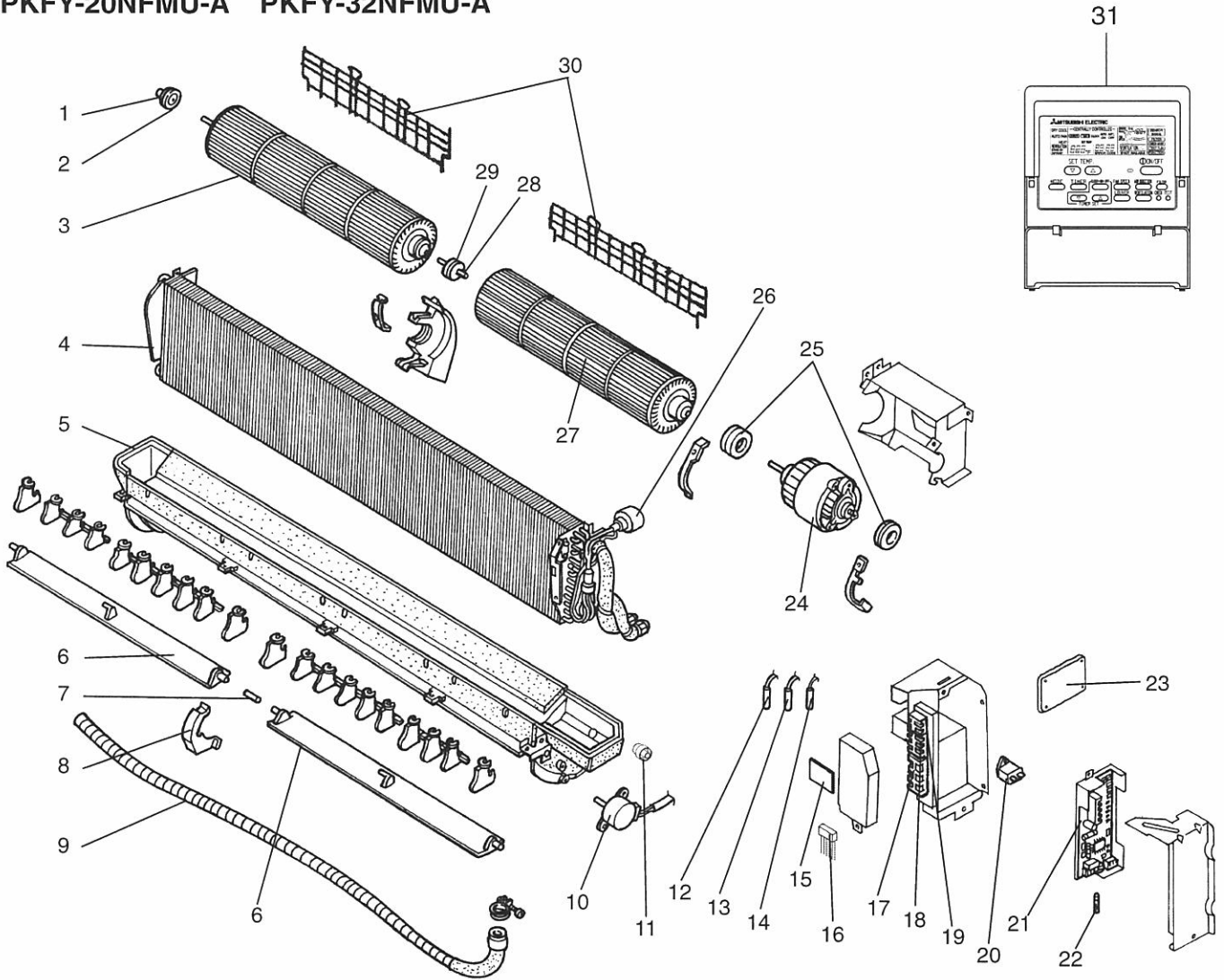

No.	Part No.	Part Name	Specification	Q'ty / set		Remarks (Drawing No.)	Wiring Diagram Symbol	Recom- mended Q'ty	Price	
				PKFY-					Unit	Amount
				20NFMU-A	32NFMU-A					
1	R01 Z61 102	BEARING MOUNT		1	1					
2	R01 12G 103	SLEEVE BEARING		1	1					
3	R01 13G 114	LEFT LINEFLOW FAN		1						
	R01 16G 114	LEFT LINEFLOW FAN			1					
4	T7W E97 480	HEAT EXCHANGER		1						
	T7W E98 480	HEAT EXCHANGER			1					
5	T7W E13 529	DRAIN PAN		1						
	T7W E14 529	DRAIN PAN			1					
6	R01 12G 002	AUTO VANE		2						
	R01 16G 002	AUTO VANE			2					
7	R01 12G 063	JOINT SHAFT		1	1					

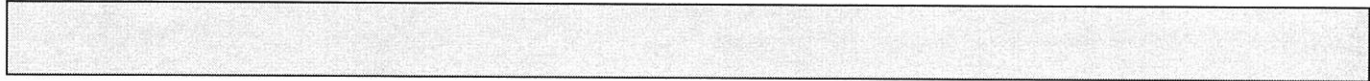

No.	Part No.	Part Name	Specification	Q'ty / set		Remarks (Drawing No.)	Wiring Diagram Symbol	Recom- mended Q'ty	Price	
				PKFY-					Unit	Amount
				20NFMU-A	32NFMU-A					
8	R01 12G 621	CENTER COVER		1	1					
9	R01 KV5 527	DRAIN HOSE		1	1					
10	T7W E03 223	VANE MOTOR		1	1		MV			
11	R01 12G 523	DRAIN SOCKET		1	1					
12	R01 E58 202	GAS PIPE THERMISTOR		1	1		TH23			
13	T7W E12 202	ROOM TEMPERATURE THERMISTOR		1	1		TH21			
14	R01 E02 202	LIQUID PIPE THERMISTOR		1	1		TH22			
15	T7W E00 294	ADDRESS BOARD		1	1		A.B			
16	R01 05A 304	ADDRESS CABLE		1	1					
17	T7W E11 716	TERMINAL BLOCK	3P(L1,L2,GR)	1	1		TB2			
18	T7W E17 716	TERMINAL BLOCK	3P(M1,M2,S)	1	1		TB5			
19	R01 556 246	TERMINAL BLOCK	2P(1,2)	1	1		TB15			
20	T7W E03 255	FAN MOTOR CAPACITOR	2.5 μ F 440V	1	1		C			
21	T7W E28 310	INDOOR CONTROLLER BOARD		1	1		I.B			
22	T7W 410 239	FUSE	250V 6A	1	1		FUSE			
23	R01 E02 313	POWER BOARD		1	1		P.B			
24	T7W B00 762	FAN MOTOR	PN4N45-K	1			MF			
	T7W B01 762	FAN MOTOR	PN4N70-K		1		MF			
25	R01 13G 105	RUBBER MOUNT		2						
	R01 16G 105	RUBBER MOUNT			2					
26	R01 E27 401	LINEAR EXPANSION VALVE		1			LEV			
	T7W E09 401	LINEAR EXPANSION VALVE			1		LEV			
27	R01 13G 115	RIGHT LINE FLOW FAN		1						
	R01 16G 115	RIGHT LINE FLOW FAN			1					
28	R01 005 103	SLEEVE BEARING		1	1					
29	R01 KV5 102	BEARING MOUNT		1	1					
30	T7W B02 675	FAN GUARD		2						
	T7W B03 675	FAN GUARD			2					
31	—	REMOTE CONTROLLER	PAR-20MAU	1	1		R.B			

This REMOTE CONTROLLER is made by AIR-CONDITIONING & REFRIGERATION SYSTEMS WORKS., MITSUBISHI ELECTRIC CORPORATION.

STRUCTURAL PARTS
PKFY-20NFMU-A
PKFY-32NFMU-A

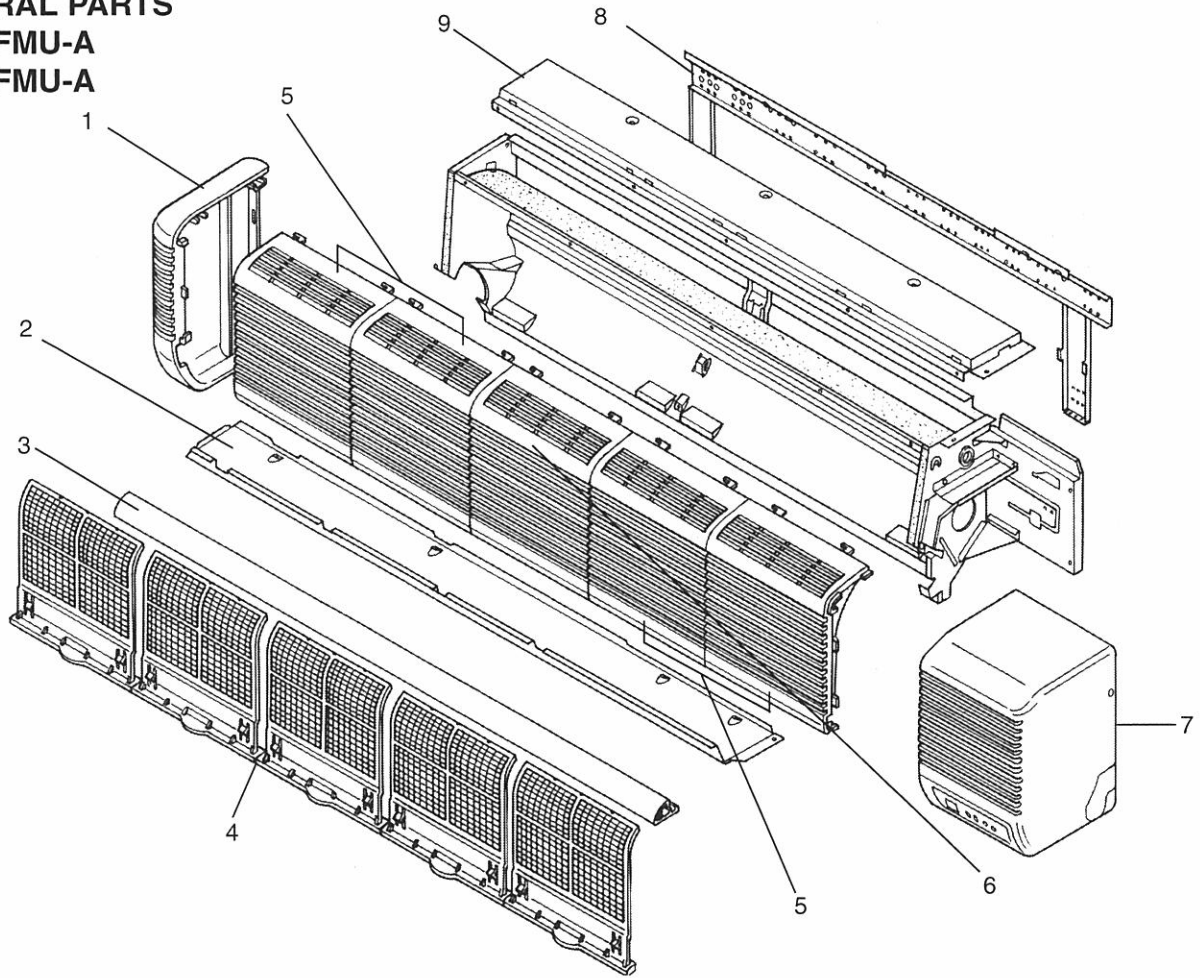

No.	Part No.	Part Name	Specification	Q'ty / set		Remarks (Drawing No.)	Wiring Diagram Symbol	Recom- mended Q'ty	Price	
				PKFY-					Unit	Amount
				20NFMU-A	32NFMU-A					
1	R01 12G 662	LEFT SIDE PANEL		1	1					
2	R01 E01 812	UNDER PLATE		1						
	R01 E00 812	UNDER PLATE			1					
3	R01 E00 811	NOSE		1						
	R01 E01 811	NOSE			1					
4	R01 A17 500	AIR FILTER		4	5					
5	R01 12G 691	INTAKE GRILLE		2	2					
6	R01 16G 692	INTAKE GRILLE			1					
7	R01 12G 661	RIGHT SIDE PANEL		1	1					
8	R01 12G 808	BACK PLATE		1						
	R01 16G 808	BACK PLATE			1					
9	R01 E01 641	TOP PLATE		1						
	R01 E00 641	TOP PLATE			1					

PLFY-12NAMU-A
PLFY-20NAMU-A
PLFY-24NAMU-A
PLFY-32NAMU-A
PLFY-40NAMU-A

CONTENTS

1. FEATURES.....	OC290- 2
2. PART NAMES AND FUNCTIONS	OC290- 4
3. SPECIFICATIONS	OC290- 6
4. 4-WAY AIR FLOW SYSTEM	OC290- 9
5. OUTLINES AND DIMENSIONS	OC290-12
6. WIRING DIAGRAM	OC290-13
7. REFRIGERANT SYSTEM DIAGRAM.....	OC290-14
8. MICROPROCESSOR CONTROL	OC290-15
9. TROUBLE SHOOTING	OC290-23
10. DISASSEMBLY PROCEDURE	OC290-28
11. PARTS LIST	OC290-31
12. OPTIONAL PARTS.....	OC290-34

1

FEATURES

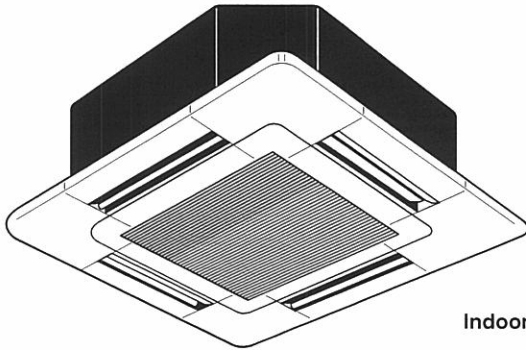

Indoor Unit

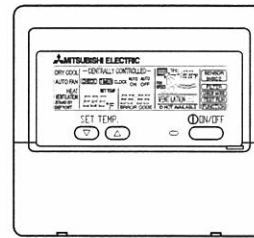

Microprocessor Remote controller

Models

PLFY-12NAMU-A
PLFY-20NAMU-A
PLFY-24NAMU-A
PLFY-32NAMU-A
PLFY-40NAMU-A

Cooling capacity / Heating capacity

12,000 / 13,000 Btu/h
20,000 / 22,500 Btu/h
24,000 / 26,500 Btu/h
32,000 / 36,000 Btu/h
40,000 / 39,000 Btu/h

1. SPACE-SAVING CENTRALLY LOCATED CEILING RECESSED INSTALLATION

2. 4-WAY AIR FLOW SYSTEM

This series allows you to select from 2, 3, and 4 way air flow directions according to your requirement. As a result, you get superb flexibility in choosing a configuration that gives you maximum cooling/heating efficiency in a neat and unobstructive installation.

3. ADVANCED MICROPROCESSOR CONTROL

(1) Easy to use Microprocessor (remote controller)

1) Ultra-Thin Remote Controller

The streamlined, wide controller is designed to blend with any kind of interior and the adoption of a sophisticated microprocessor allows you to carry out a wide range of operations easily.

2) Attractive Liquid Crystal Display (LCD)

Units operation mode, set temperature, room temperature, timer setting, fan speed, and air flow direction are displayed on the remote controller with the easily understood visual Liquid Crystal Display (LCD).

3) Convenient 24-Hour ON-OFF Timer

The timer allows Mr.SLIM to be switched on or off automatically at the time is shown on the LCD.

4) Self-Diagnostic Feature Indicates Faults Instantly

In the rare case when a problem occurs, the unit stops operating and the set temperature indicator changes to the self-diagnostic indicator, indicating the location of the fault.

If the check switch is pressed twice, the unit stops operating and the check mode is initiated. The cause of the most recent problem stored in the memory is displayed on the LCD. This is extremely useful for maintenance purposes.

5) Useful Memory Feature for Storing Instructions

The previous set value is memorised so that constant temperature control can be obtained. This is convenient when, for example, a power failure occurs.

(2) Non-polar Two-Wire Remote Controller Cables

The non-polar, two-wire type remote controller cable is slim, installation is simple and trouble-free. Remote controller wire can be extended up to 550 yards.

(3) Automatic Cooling/Heating Changeover Operation

An automatic cooling and heating changeover operation system is provided to ensure easy control and year-round air conditioning.

Once the desired temperature is set, unit operation is switched automatically between cooling and heating, in accordance with the room temperature.

4. DRAIN PUMP FOR EASY PIPE CONNECTION (DRAIN LIFT-UP MECHANISM)

This mechanism, with its capacity to raise drain water 33-7/16 inch above the ceiling line, is convenient for removing water and avoiding piping contact with beams, etc.

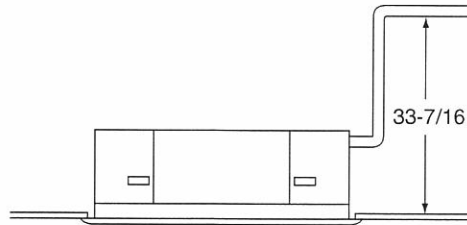

5. FRESH AIR INTAKE AND BRANCH DUCTING ARE AVAILABLE (on-site work)

6. HIGH RELIABILITY AND EASY SERVICING.

In addition to the self-diagnostic function, units are also equipped with a 3-minute time delay mechanism (cooling), an auto restart function, an emergency operation function, a test run switch, etc., to assure high reliability and easy servicing.

7. NITROGEN GAS IS CHARGED TO INDOOR UNIT.

Indoor unit and refrigerant pipes are charged with nitrogen gas (N₂) instead of (R22) before shipment from the factory.

2

PART NAMES AND FUNCTIONS

● Indoor (Main) Unit

Horizontal Air Outlet

Sets airflow horizontal automatically during cooling or dehumidifying.

Filter

Remove dust and pollutants from return air

Grille

Auto Air Swing Vane

Disperses airflow up and down and adjusts the angle of airflow direction.

Air Intake

Returns air from room.

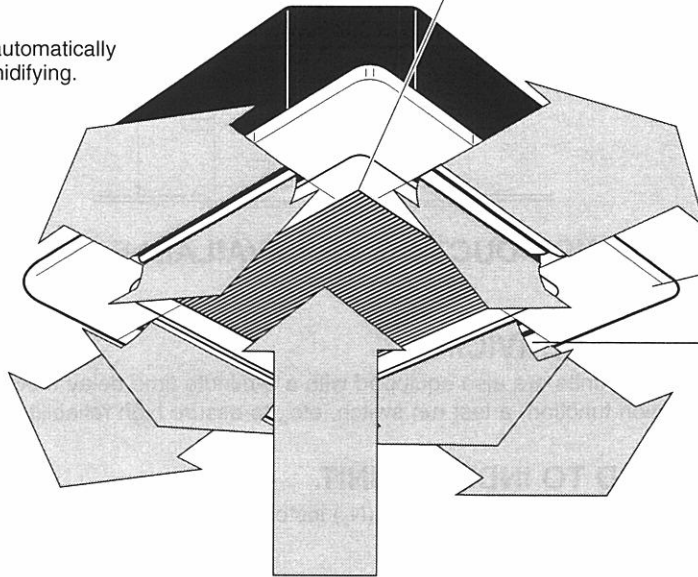

● Remote controller

- Once the controls are set, the same operation mode can be repeated by simply pressing the ON/OFF button.

● Operation buttons

TEMP. ADJUSTMENT button

This sets the room temperature. The temperature setting can be performed in 2°F units
Setting range
Cooler 67°F to 87°F
Heater 63°F to 83°F

TIME SETTING button

This sets the current time, start time and stop time.

AIR SPEED button

This sets the ventilation fan speed.

TIMER button

This switches between continuous operation and the timer operation.

ON/OFF button

This switches between the operation and stop modes each time it is pressed. The lamp on this button lights during operation.

OPERATION SWITCH button

Press this button to switch the cooler, electronic dry (dehumidify), automatic and heater modes.

AIR DIRECTION button

This adjusts the vertical angle of the ventilation.

LOUVER button

This switch the horizontal fan motion ON and OFF.

(Not available for this model.)

CHECK-TEST RUN button

Only press this button to perform an inspection check or test operation. Do not use it for normal operation.

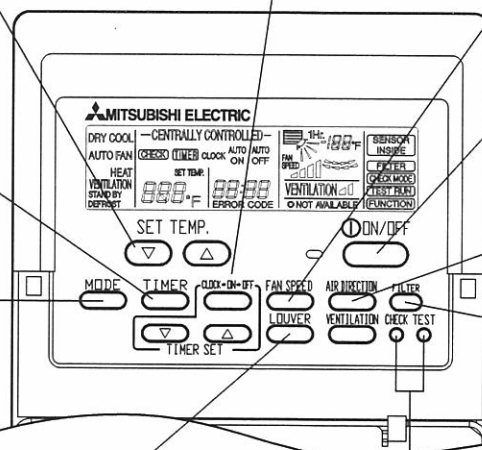

● Display

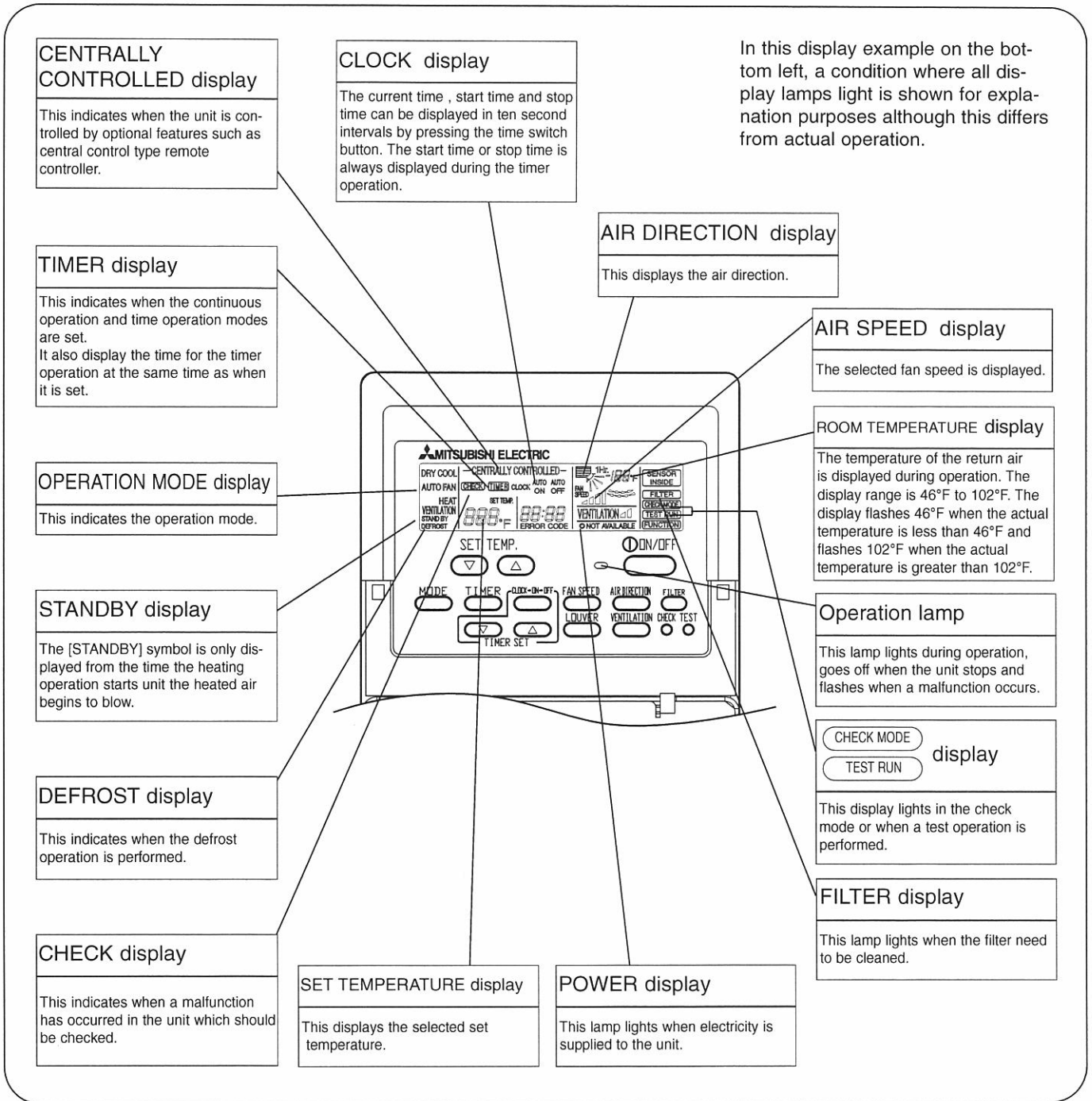

Caution

- Only the Power display lights when the unit is stopped and power supplied to the unit.
- When the central control remote control unit, which is sold separately, is used the ON-OFF button, operation switch button and TEMP. adjustment button do not operate.
- "NOT AVAILABLE" is displayed when the Air speed button is pressed. This indicates that this room unit is not equipped with the fan direction adjustment function and the louver function.
- When power is turned ON for the first time, it is normal that "H0" is displayed on the room temperature indication (For max. 2minutes). Please wait until this "H0" indication disappear then start the operation.

3

SPECIFICATIONS

3-1. Specifications

Item		PLFY-12NAMU-A	PLFY-20NAMU-A	PLFY-24NAMU-A	PLFY-32NAMU-A	PLFY-40NAMU-A		
Power	V·Hz	Single phase 208/230V 60Hz						
Cooling capacity	Btu/h	12,000	20,000	24,000	32,000	40,000		
Heating capacity	Btu/h	13,000	22,500	26,500	36,000	39,000		
Electric characteristic	Input	Cooling	kW	0.14	0.14	0.14	0.27	0.27
		Heating	kW	0.14	0.14	0.14	0.27	0.27
	Current	Cooling	A	0.68	0.68	0.68	1.30	1.30
		Heating	A	0.68	0.68	0.68	1.30	1.30
Exterior (munsell symbol)	—	Unit : Galvanized sheets with gray heat insulation Grills : ABS resin Munsell<0.70Y 8.59/0.97>						
Dimensions	Height	in	10-3/16<1-3/16>		11-3/4<1-3/16>			
	Width	in	33-1/16<37-3/8>					
	Depth	in	33-1/16<37-3/8>					
Heat exchanger	—	Cross fin						
Fan	Fan × No	—	Turbo fan × 1					
	Air flow ※3	DRY	CFM	390-420-460-490	490-530-570-640	530-570-640-710	710-810-920-990	780-880-990-1060
		WET	CFM	350-380-410-440	470-500-530-600	500-530-600-670	670-770-870-930	730-830-930-1000
	External static pressure	Pa	0					
	Fan motor output	kW	0.070		0.110			
Insulator	—	Polyethylene sheet						
Air filter	—	PP honey comb fabric						
Pipe dimensions	Gas side	in	1/2"	5/8"		3/4"		
	Liquid side	in	1/4"	3/8"				
Unit drain pipe size	in	PVC with O.D.1-1/4"						
Noise level ※3	dB	24-27-28-30	27-28-31-33	28-30-33-34	34-36-40-41	37-40-43-44		
Product weight	lb	49<11>	53<11>		66<11>			

Note 1. Rating conditions

Cooling : Indoor : D.B. 80°F W.B. 67°F
 outdoor : D.B. 95°F W.B. 75°F
 Heating : Indoor : D.B. 70°F
 outdoor : D.B. 47°F W.B. 43°F

Note 2. The number indicated in < > is just for the grille.

※ 3. Air flow and the noise level are indicated as Low - Medium2 - Medium1 - High.

• Connected outdoor unit is PURY-80TMU or PURY-100TMU.

3-2. NOISE CRITERION CURVES

PLFY-12NAMU-A

NOTCH	SPL(dB)	LINE
Hi	30	○—○
Med1	28	△—△
Med2	27	●—●
Lo	24	▲—▲

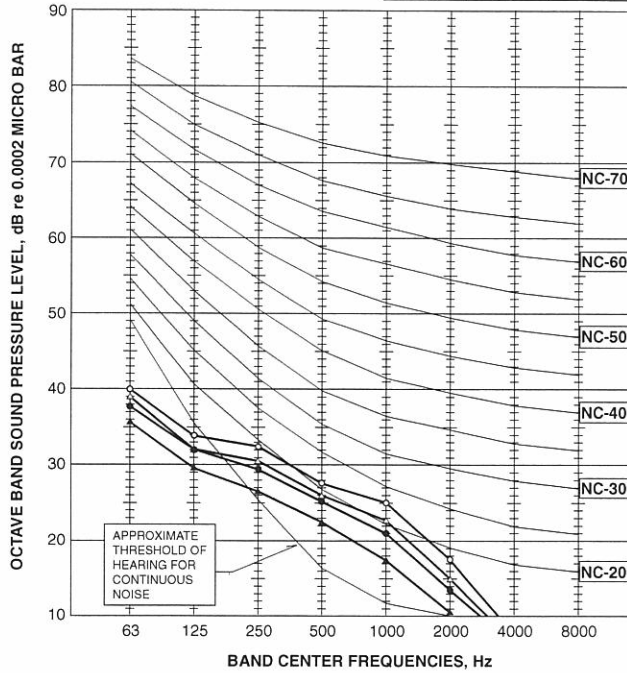

PLFY-20NAMU-A

NOTCH	SPL(dB)	LINE
Hi	33	○—○
Med1	31	△—△
Med2	28	●—●
Lo	27	▲—▲

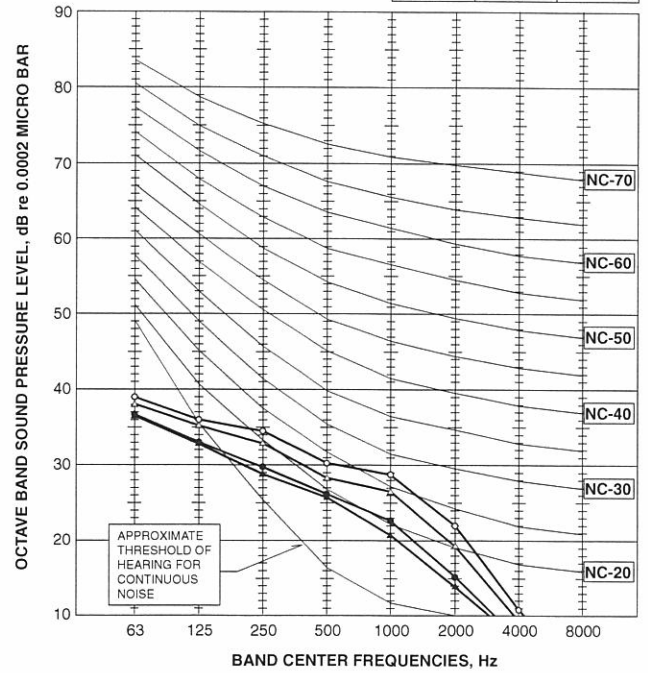

PLFY-24NAMU-A

NOTCH	SPL(dB)	LINE
Hi	34	○—○
Med1	33	△—△
Med2	30	●—●
Lo	28	▲—▲

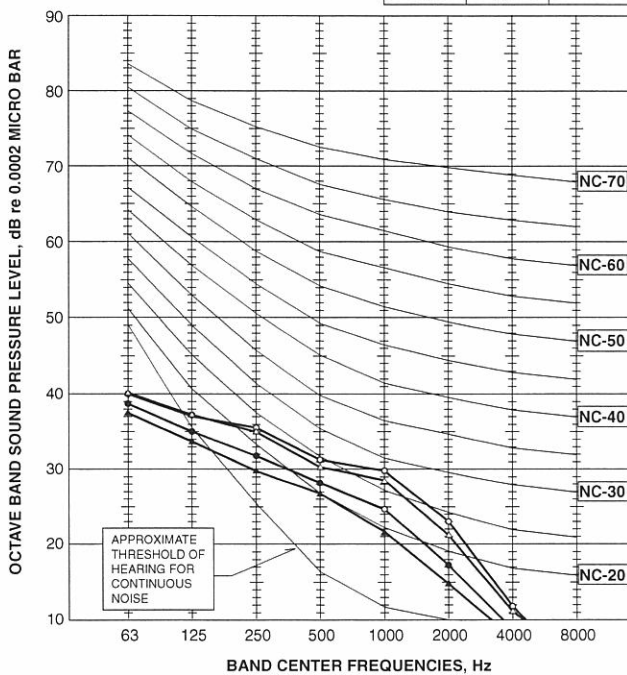

PLFY-32NAMU-A

NOTCH	SPL(dB)	LINE
Hi	41	○—○
Med1	40	△—△
Med2	36	●—●
Lo	34	▲—▲

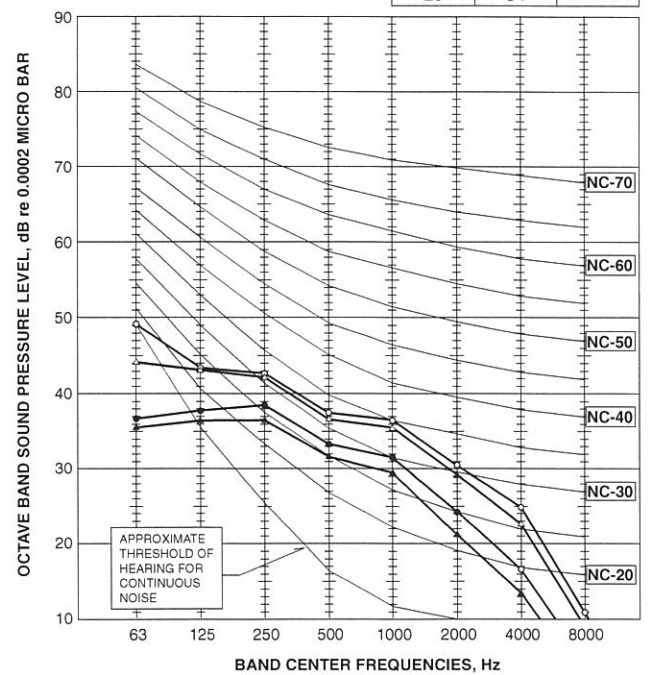

PLFY-40NAMU-A

NOTCH	SPL(dB)	LINE
Hi	44	○—○
Med1	43	△—△
Med2	40	●—●
Lo	37	▲—▲

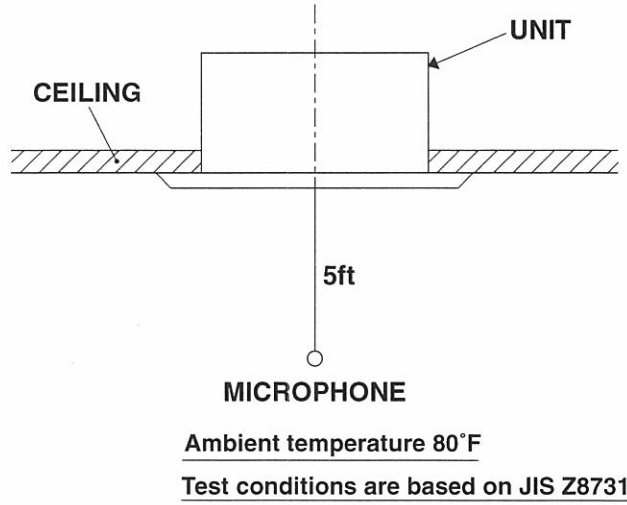
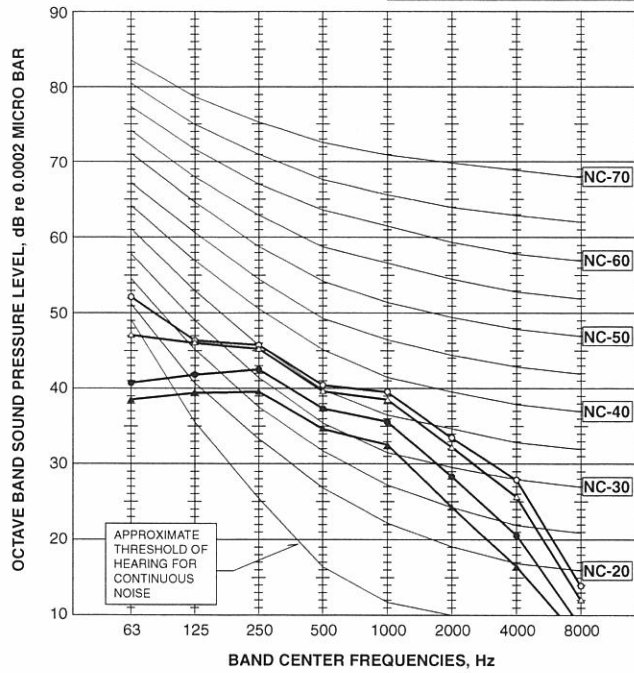

3-3. Electrical parts specifications

Model	Symbol	PLFY-12NAMU-A	PLFY-20NAMU-A	PLFY-24NAMU-A	PLFY-32NAMU-A	PLFY-40NAMU-A
Parts name						
Room temperature thermistor	TH21	Resistance 30°F/15.8kΩ, 50°F/9.6kΩ, 70°F/6.0kΩ, 80°F/4.8kΩ, 90°F/3.9kΩ, 100°F/3.2kΩ				
Liquid pipe thermistor	TH22	Resistance 30°F/15.8kΩ, 50°F/9.6kΩ, 70°F/6.0kΩ, 80°F/4.8kΩ, 90°F/3.9kΩ, 100°F/3.2kΩ				
Gas pipe thermistor	TH23	Resistance 30°F/15.8kΩ, 50°F/9.6kΩ, 70°F/6.0kΩ, 80°F/4.8kΩ, 90°F/3.9kΩ, 100°F/3.2kΩ				
Fuse (Indoor controller board)	FUSE	250V 6A				
Fan motor (with inner-thermostat)	MF	6-pole OUTPUT 70W D17D6P70MS			6-pole OUTPUT 110W D176P110MS	
		Inner-thermostat OPEN 266°F ± 9°F				
Fan motor capacitor	C	3.0μF × 440V			7.0μF × 440V	
Vane motor	MV	MSBPC20M13 DC12V 300Ω/phase				
Drain-up mechanism	DP	PLD-12220ME-2 INPUT 12/10.8W 24 ℓ /Hr				
Drain sensor	DS	Thermistor resistance 30°F/6.3kΩ, 50°F/3.9kΩ, 70°F/2.5kΩ, 80°F/2.0kΩ, 90°F/1.6kΩ, 100°F/1.3kΩ				
Linear expansion valve	LEV	DC12V Stepping motor drive port dimension 3.2Ω (0~2000pulse) EDM-40YHME			DC12V Stepping motor drive port dimension 5.2Ω (0~2000pulse) EDM-80YHME	
Electric heater (Condensation proof)	H2	240V 21.8W				
Power supply terminal block	TB2	(L1, L2, GR) 330V 30A				
Transmission terminal block	TB5	(M1, M2, S) 250V 20A				
MA remote controller terminal block	TB15	(1, 2) 250V 10A				

4 4-WAY AIR FLOW SYSTEM

4-1. Placement of the air outlets

- For this grille, the blowout direction comes in 11 patterns. Also, by setting the dip switches (SWA and SWB) on the address board to the appropriate settings, you can adjust the air flow and speed. Select the settings from Table according to the location in which you want to install the unit.

1) Decide on the pattern of the airflow direction.

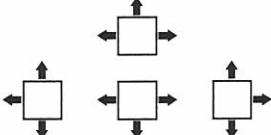
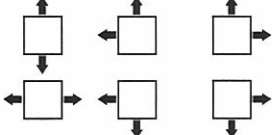
<Table 1>	4-direction	3-direction	2-direction
Blowout direction pattern	Pattern 1 Factory setting 	Pattern 4 One air outlet fully closed 	Pattern 6 Two air outlet fully closed 

Note1.
For 3 and 2-directional, please use the air outlet shutter plate (option).

- 2) According to the number of air outlets and height of the ceiling to install the unit, be sure to set the up switches (SWA, SWB) on the indoor board to the appropriate setting.
- Correspondence of ceiling heights to numbers of air outlets.

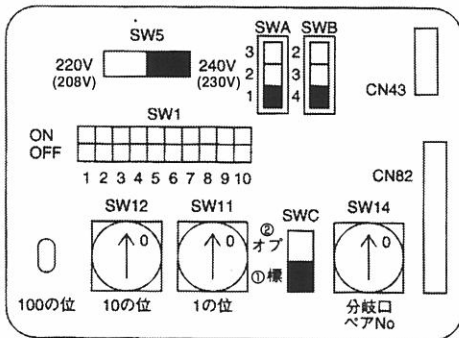

PLFY-12, 20NAMU-A (Unit : feet)

SWB	SWA	①	②	③
		Standard	High ceiling ①	High ceiling ②
④	4 direction	8.9	9.8	11.5
③	3 direction	9.8	10.8	11.5
②	2 direction	10.8	11.5	—

PLFY-24, 32, 40NAMU-A (Unit : feet)

SWB	SWA	①	②	③
		Standard	High ceiling ①	High ceiling ②
④	4 direction	10.5	11.8	13.8
③	3 direction	11.8	13.1	13.8
②	2 direction	13.1	13.8	—

4-2. Fresh air intake (Installation of site)

- At the time of installation, use the duct holes (cutout) located at the positions shown in following diagram, as and when required.

Note :

Be sure to add 5-5/16inch to the dimensions in the diagram that are marked with a “※” if installing a multi function casement (Option)

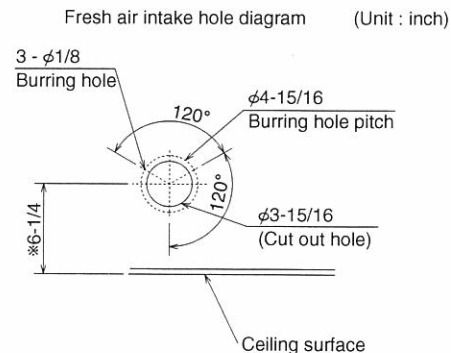
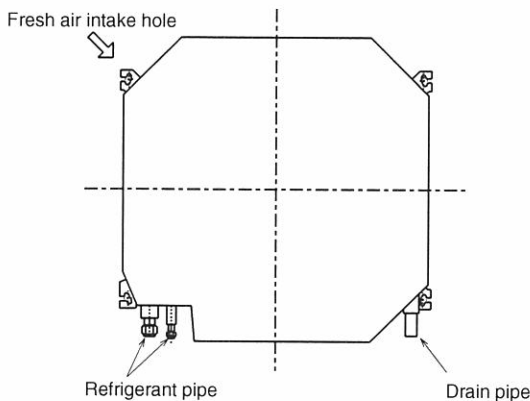

4-3. Interlocking operation method with duct fan (Booster fan)

- Whenever the indoor unit is operating, the duct fan also operates.
 - (1) Connect the optional multiple remote controller adapter (PAC-SA88HA-E) to the connector CN51 on the indoor controller board.
 - (2) Drive the relay after connecting the 12V DC relay between the Yellow and Orange connector lines.
- (※) Use a relay under 1W.
- MB: Electromagnetic switch power relay for duct fan.
- X: Auxiliary relay (12V DC LY-1F)

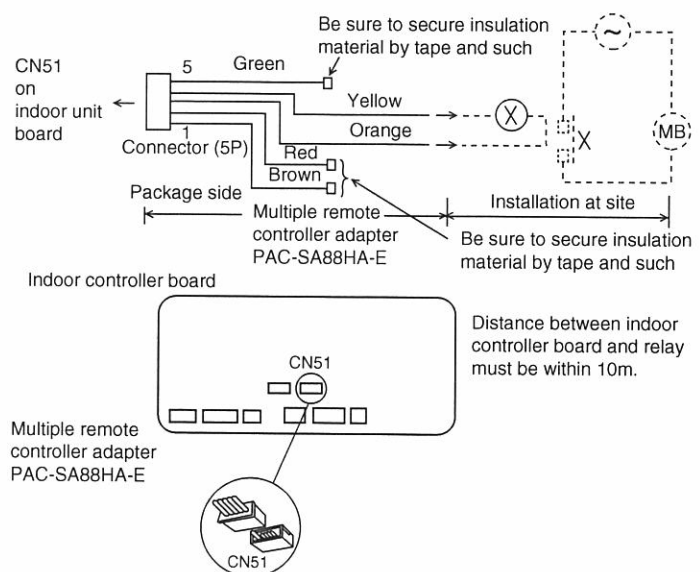

4-4. Fresh air intake amount & static pressure characteristics

□ PLFY-12, 20, 24NAMU-A

Multifunction casement + Standard filter

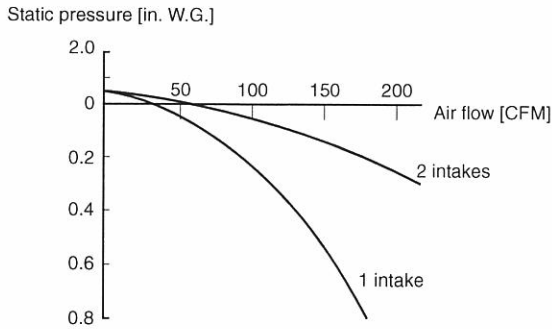

Multifunction casement + High efficiency filter

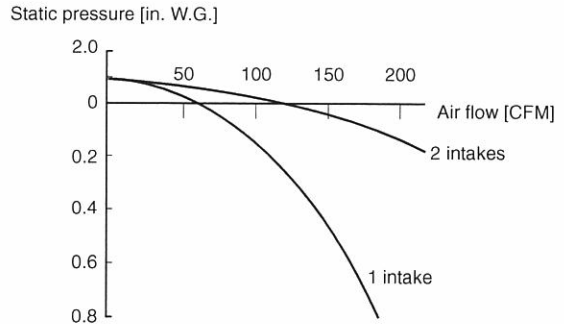

Taking air into the unit

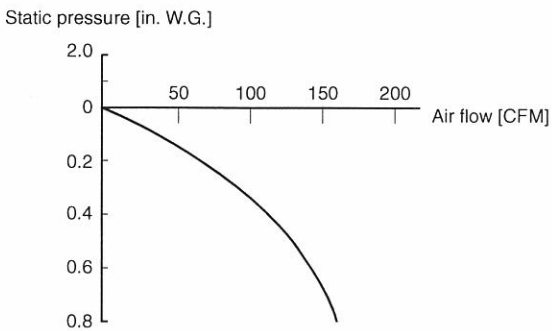

How to read curves

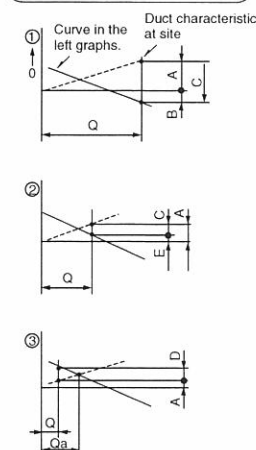

- Q...Planned amount of fresh air intake <CFM>
- A...Static pressure loss of fresh air intake duct system with air flow amount Q <in.W.G.>
- B...Forced static pressure at air conditioner inlet with air flow amount Q <in.W.G.>
- C...Static pressure of booster fan with air flow amount Q <in.W.G.>
- D...Static pressure loss increase amount of fresh air intake duct system for air flow amount Q <in.W.G.>
- E...Static pressure of indoor unit with air flow amount Q <in.W.G.>
- Qa...Estimated amount of fresh air intake with out D <CFM>

□ PLFY-32, 40NAMU-A

Multifunction casement + Standard filter

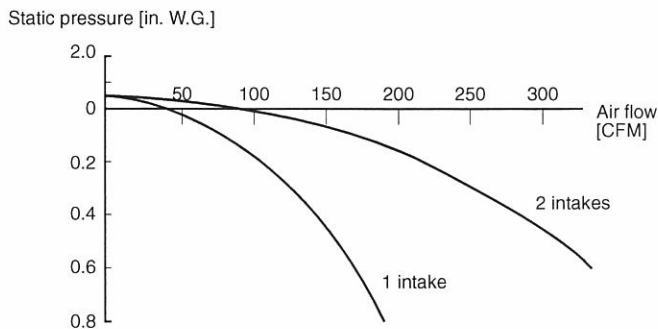

Multifunction casement + High efficiency filter

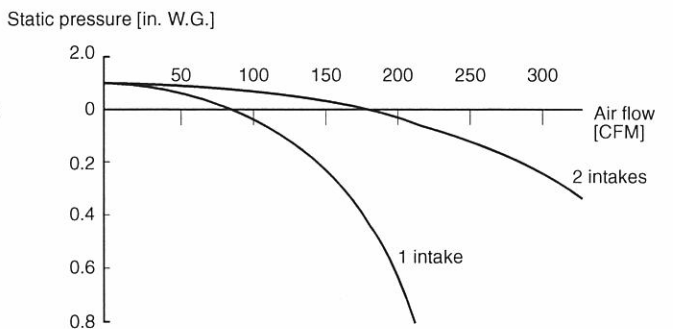

Taking air into the unit

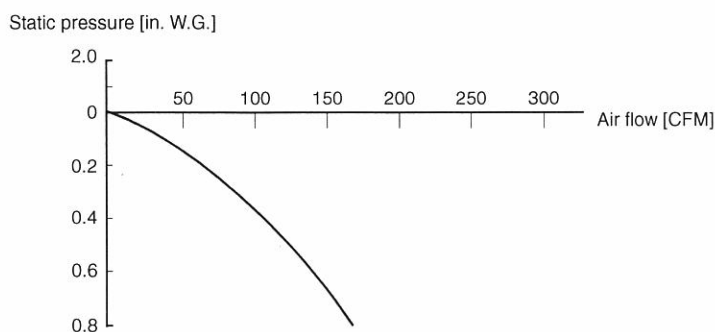

6

WIRING DIAGRAM

PLFY-12NAMU-A
 PLY-20NAMU-A
 PLY-24NAMU-A

PLFY-32NAMU-A
 PLY-40NAMU-A

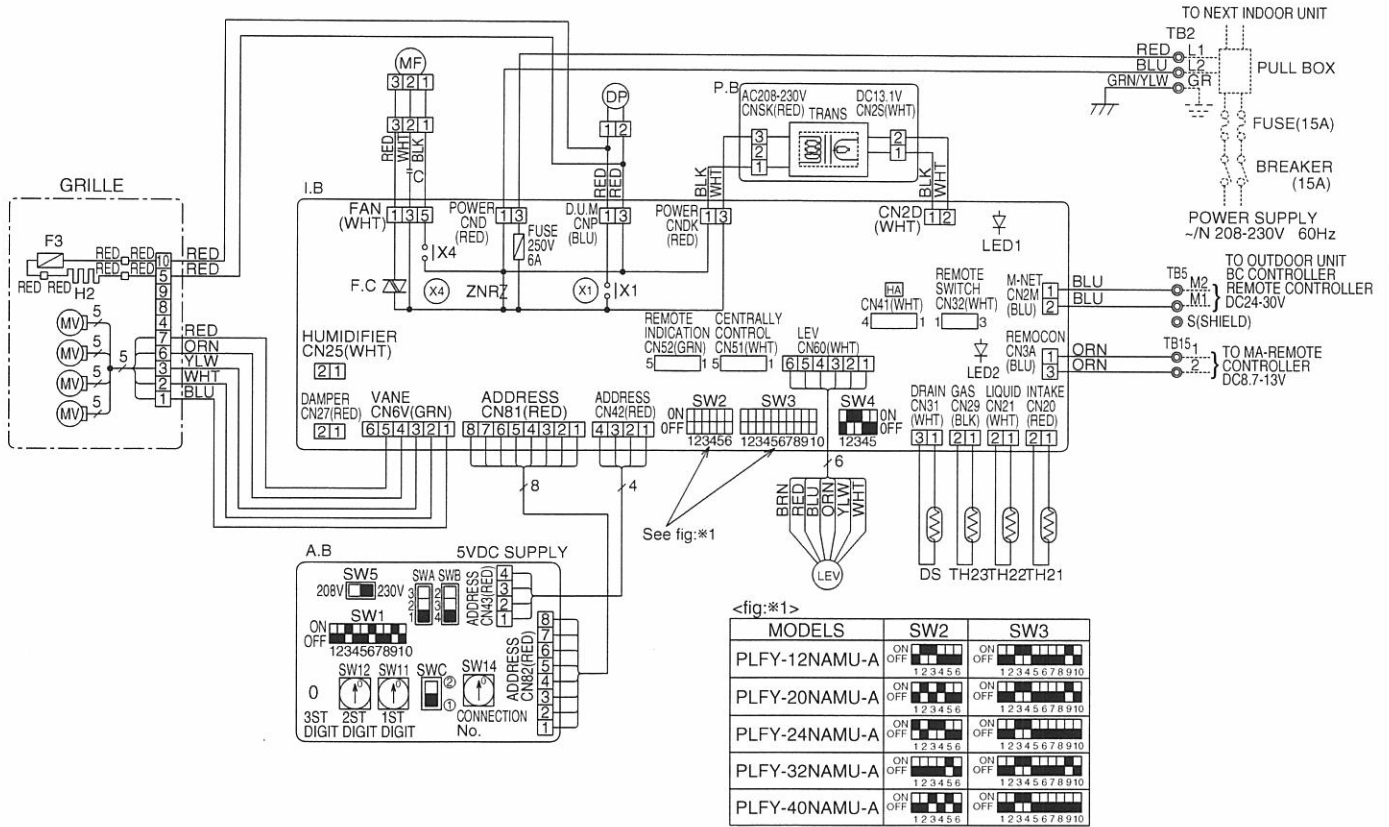

Notes:

- At servicing for outdoor unit, always follow the wiring diagram of outdoor unit.
- In case of using MA-Remote controller, please connect to TB15. (Remote controller wire is non-polar.)
- In case of using M-NET, please connect to TB5. (Transmission line is non-polar.)
- Symbol [S] of TB5 is the shield wire connection.
- Symbols used in wiring diagram above are,
 - ⊙: terminal block, □: connector.
- The setting of the SW2 dip switches differs in the capacity for the detail, refer to the fig:*1.
- Please set the switch SW5 according to the power supply voltage. Set SW5 to 230V side when the power supply is 230 volts. When the power supply is 208 volts, set SW5 to 208V side.

LED on indoor board for service

Mark	Meaning	Function
LED1	Main power supply	Main power supply (Indoor unit: 208-230V) power on → lamp is lit
LED2	Power supply for MA-Remote controller	Power supply for MA-Remote controller on → lamp is lit

[LEGEND]

SYMBOL	NAME	SYMBOL	NAME
A.B	CIRCUIT BOARD (ADDRESS)	C	CAPACITOR (FAN MOTOR)
SW1	SWITCH MODE SELECTION	DP	DRAIN WATER LIFTING-UP MACHINE
SW5	VOLTAGE SELECTION	DS	DRAIN SENSER
SW11	ADDRESS SETTING 1ST DIGIT	F3	FUSE (0.16A/250V)
SW12	ADDRESS SETTING 2ND DIGIT	H2	DEW PREVENTION HEATER
SW14	CONNECTION No.	LEV	LINEAR EXPANSION VALVE
SWA	CEILING HEIGHT SELECTOR	MF	FAN MOTOR (WITH INNER THERMOSTAT)
SWB	DISCHARGE OUTLET NUMBER SELECTOR	MV	VANE MOTOR
SWC	OPTION SELECTOR	TB2	TERMINAL POWER SUPPLY
I.B	INDOOR CONTROLLER BOARD	TB5	BLOCK TRANSMISSION
CN25	CONNECTOR HUMIDIFIER	TB15	MA-REMOTE CONTROLLER
CN27	DAMPER	TH21	THERMISTOR ROOM TEMP. DETECTION (32°F/15kΩ, 77°F/5.4kΩ)
CN32	REMOTE SWITCH	TH22	PIPE TEMP. DETECTION/LIQUID (32°F/15kΩ, 77°F/5.4kΩ)
CN41	HA TERMINAL-A	TH23	PIPE TEMP. DETECTION/GAS (32°F/15kΩ, 77°F/5.4kΩ)
CN51	CENTRALLY CONTROL		
CN52	REMOTE INDICATION		
F.C	FAN PHASE CONTROL		
FUSE	FUSE (6A/250V)		
SW2	SWITCH CAPACITY CODE		
SW3	MODE SELECTION		
SW4	MODEL SELECTION		
X1	AUX. RELAY DRAIN PUMP		
X4	FAN MOTOR		
ZNR	VARIATOR		
P.B	INDOOR POWER BOARD		

7

REFRIGERANT SYSTEM DIAGRAM

PLFY-12NAMU-A PLYF-32NAMU-A
 PLYF-20NAMU-A PLYF-40NAMU-A
 PLYF-24NAMU-A

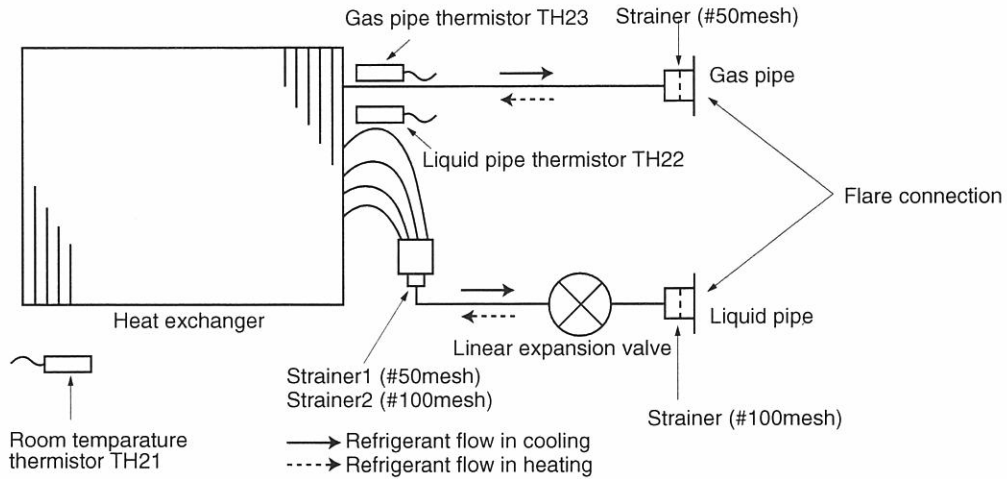

Service Ref.	PLFY-12NAMU-A	PLFY-20, 24, 32NAMU-A	PLFY-40NAMU-A
Item			
Gas pipe	1/2"	5/8"	3/4"
Liquid pipe	1/4"	3/8"	3/8"

INDOOR UNIT CONTROL

8-1. COOL operation

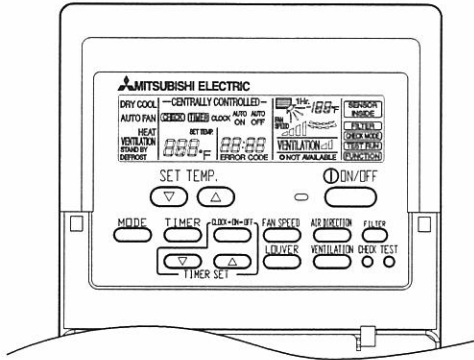

<How to operate>

- ① Press POWER ON/OFF button.
- ② Press the operation MODE button to display COOL.
- ③ Press the SET TEMP. button to set the desired temperature.

NOTE: The set temperature changes 2°F when the ∇ or Δ button is pressed one time Cooling 67 to 87°F.

Control modes	Control details	Remarks				
1. Thermoregulating function	1-1. Thermoregulating function (Function to prevent restarting for 3 minutes) <ul style="list-style-type: none"> • Room temperature \geq desired temperature + 2°F ...Thermo ON • Room temperature \leq desired temperature ...Thermo OFF 					
	1-2. Anti-freezing control <p>Detected condition : When the liquid pipe temp. (TH22) is 36°F or less in 16 minutes from compressors start up, anti-freezing control starts and the thermo OFF.</p> <p>Released condition : The timer which prevents reactivating is set for 3 minutes, and anti- freezing control is cancelled when any one of the following conditions is satisfied.</p> <ol style="list-style-type: none"> ① Liquid pipe temp. (TH22) turn 50°F or above. ② The condition of the thermo OFF has become complete by thermoregulating, etc. ③ The operation modes became mode other than COOL. ④ The operation stopped. 					
2. Fan	By the remote controller setting (switch of 4 speeds) <table border="1" style="margin-left: auto; margin-right: auto;"> <thead> <tr> <th>Type</th> <th>Fan speed notch</th> </tr> </thead> <tbody> <tr> <td>4 speeds type</td> <td>[Low], [Med2], [Med1], [High]</td> </tr> </tbody> </table>	Type	Fan speed notch	4 speeds type	[Low], [Med2], [Med1], [High]	
Type	Fan speed notch					
4 speeds type	[Low], [Med2], [Med1], [High]					

To be continued on the next page.

From the preceding page.

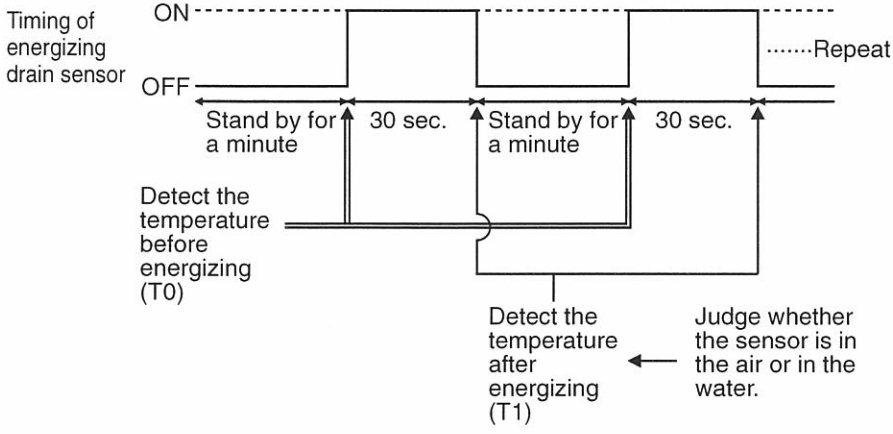
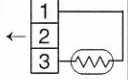
Control modes	Control details	Remarks
<p>3. Drain pump</p>	<p>3-1. Drain pump control</p> <ul style="list-style-type: none"> •Always drain pump ON during the COOL and DRY mode operation. (Regardless of the thermo ON/ OFF) •When the operation mode has changed from the COOL or DRY to the others (including Stop), OFF the control after the drain pump ON for 3 minutes. <p>Drain sensor function</p> <ul style="list-style-type: none"> • Energize drain sensor at a fixed voltage for a fixed duration. After energizing, compare the drain sensor's temperature to the one before energizing, and judge whether the sensor is in the air or in the water. <p>Basic control system</p> <ul style="list-style-type: none"> • While drain pump is turned on, repeat the following control system and judge whether the sensor is in the air or in the water.  <ul style="list-style-type: none"> •Drain sensor temperature rise (Δt) •Temperature of drain sensor before current is applied (T_0) •Temperature of drain sensor after current is applied (T_1) <p>[$\Delta t = T_1 - T_0$]</p>	<p>*1 Drain sensor Indoor control p.c. board CN31</p> 
<p>4. Vane (up/ down vane change)</p>	<p>(1) Initial setting : Start at COOL mode and horizontal vane.</p> <p>(2) Vane position : Horizontal →Downward A →Downward B →Downward C→Swing</p> <p>(3) Restriction of the downward vane setting When setting the downward vane A, B or C in [Med1], [Med2] or [Low] of the fan speed notch, the vane changes to horizontal position after 1 hour have passed.</p>	<p>*1 "SET FOR 1 HOUR" appears on the wired remote controller.</p>

8-2. DRY operation

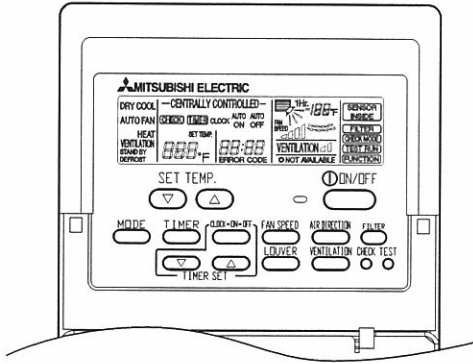

<How to operate>

- ① Press POWER ON/OFF button.
 - ② Press the operation MODE button to display DRY.
 - ③ Press the SET TEMP. button to set the desired temperature.
- NOTE:** The set temperature changes 2°F when the ∇ or Δ button is pressed one time. Dry 67 to 87°F.

Control modes	Control details	Remarks																															
1. Thermoregulating function	<p>1-1. Thermoregulating function (Function to prevent restarting for 3 minutes) Setting the Dry thermo by the thermoregulating signal and the room temperature (TH1). Dry thermo ON Room temperature \geq desired temperature + 2°F Dry thermo OFF Room temperature \leq desired temperature</p> <table border="1"> <thead> <tr> <th rowspan="2">Room temperature</th> <th colspan="2">3 min. passed since starting operation</th> <th rowspan="2">Dry thermo ON time (min)</th> <th rowspan="2">Dry thermo OFF time (min)</th> </tr> <tr> <th>Thermoregulating signal</th> <th>Room temperature (T1)</th> </tr> </thead> <tbody> <tr> <td rowspan="4">Over 64°F</td> <td rowspan="4">ON</td> <td>T1 \geq 82°F</td> <td>9</td> <td>3</td> </tr> <tr> <td>82°F > T1 \geq 79°F</td> <td>7</td> <td>3</td> </tr> <tr> <td>79°F > T1 \geq 75°F</td> <td>5</td> <td>3</td> </tr> <tr> <td>75°F > T1</td> <td>3</td> <td>3</td> </tr> <tr> <td></td> <td>OFF</td> <td>Unconditional</td> <td>3</td> <td>10</td> </tr> <tr> <td>Less than 64°F</td> <td colspan="4">Dry thermo OFF</td> </tr> </tbody> </table>	Room temperature	3 min. passed since starting operation		Dry thermo ON time (min)	Dry thermo OFF time (min)	Thermoregulating signal	Room temperature (T1)	Over 64°F	ON	T1 \geq 82°F	9	3	82°F > T1 \geq 79°F	7	3	79°F > T1 \geq 75°F	5	3	75°F > T1	3	3		OFF	Unconditional	3	10	Less than 64°F	Dry thermo OFF				
	Room temperature		3 min. passed since starting operation				Dry thermo ON time (min)	Dry thermo OFF time (min)																									
Thermoregulating signal		Room temperature (T1)																															
Over 64°F	ON	T1 \geq 82°F	9	3																													
		82°F > T1 \geq 79°F	7	3																													
		79°F > T1 \geq 75°F	5	3																													
		75°F > T1	3	3																													
	OFF	Unconditional	3	10																													
Less than 64°F	Dry thermo OFF																																
	<p>1-2. Frozen prevention control No control function</p>																																
2. Fan	<p>Indoor fan operation controlled depends on the compressor conditions.</p> <table border="1"> <thead> <tr> <th>Dry thermo</th> <th>Fan speed notch</th> </tr> </thead> <tbody> <tr> <td>ON</td> <td>[Low]</td> </tr> <tr> <td>OFF</td> <td>Stop</td> </tr> </tbody> </table> <p>Note: Remote controller setting is not acceptable.</p>	Dry thermo	Fan speed notch	ON	[Low]	OFF	Stop																										
Dry thermo	Fan speed notch																																
ON	[Low]																																
OFF	Stop																																
3. Drain pump	Same control as COOL operation																																
4. Vane (up/ down vane change)	Same control as COOL operation																																

8-3. FAN operation

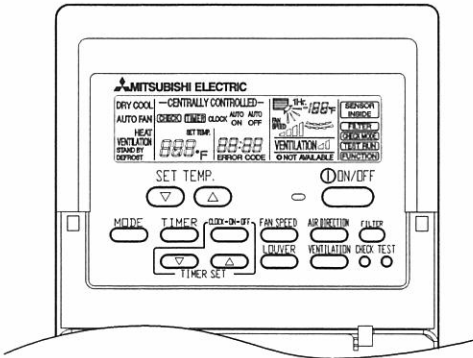

<How to operate>

- ① Press POWER ON/OFF button.
- ② Press the operation MODE button to display FAN.

Control modes	Control details	Remarks				
1. Fan	Set by remote controller. <table border="1" data-bbox="405 860 1018 936" style="margin-left: 40px;"> <tr> <td data-bbox="405 860 635 898">Type</td> <td data-bbox="635 860 1018 898">Fan speed notch</td> </tr> <tr> <td data-bbox="405 898 635 936">4 speeds type</td> <td data-bbox="635 898 1018 936">[Low], [Med2], [Med1], [High]</td> </tr> </table>	Type	Fan speed notch	4 speeds type	[Low], [Med2], [Med1], [High]	
Type	Fan speed notch					
4 speeds type	[Low], [Med2], [Med1], [High]					
2. Drain pump	<p>2-1. Drain pump control The drain pump turns ON for the specified amount of time when any of the following conditions is met:</p> <ul style="list-style-type: none"> ① ON for 3 minutes after the operation mode is switched from COOL or DRY to another operation mode (FAN). ② ON for 6 minutes after the drain sensor is determined to be submerged using the liquid level detection method given below. ③ ON for 6 minutes after indoor piping (liquid piping) temperature – indoor intake temperature $\leq -18^{\circ}\text{F}$, AND the drain sensor input is at the short or open level. (If condition ② or ③ is still being met after the drain pump has been turned ON for 6 minutes, the drain pump is kept ON for a further 6 minutes.) <p>2-2. Liquid level detection method The liquid level is detected by determining whether or not the drain sensor is submerged, based on the amount the temperature rises after self-heating the sensor. This process is performed if any of the following conditions is met:</p> <ul style="list-style-type: none"> ① Drain pump is ON. ② Indoor piping (liquid piping) temperature – indoor intake temperature $\leq -18^{\circ}\text{F}$ ③ Indoor piping (liquid piping) temperature or indoor intake temperature is at the short or open level temperature. ④ Every hour after the drain pump has been switched from ON to OFF. 					
3. Vane (up/ down vane change)	Same as the control performed during the COOL operation, but with no restriction on the vane's downward blow setting.					

8-4. HEAT operation

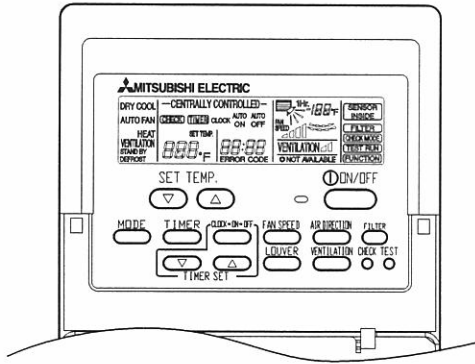

<How to operate>

- ① Press POWER ON/OFF button.
- ② Press the operation MODE button to display HEAT.
- ③ Press the SET TEMP. button to set the desired temperature.

NOTE: The set temperature changes 2°F when the ∇ or \triangle button is pressed one time. Heating 63 to 83°F.

<Display in HEAT operation>

[DEFROST]

The [DEFROST] symbol is only displayed during the defrost operation.

[STANDBY]

The [STANDBY] symbol is only displayed from the time the heating operation starts until the heated air begins to blow.

Control modes	Control details	Remarks
1. Thermoregulating function	<p>1-1. Thermoregulating function (Function to prevent restarting for 3 minutes)</p> <ul style="list-style-type: none"> • Room temperature \leq desired temperature -2°F ...Thermo ON • Room temperature \geq desired temperature ...Thermo OFF 	
2. Fan	<p>Controlled by the remote controller (4-speed) Give priority to under-mentioned controlled mode</p> <p>2-1. Hot adjuster mode 2-2. Preheating exclusion mode 2-3. Thermo OFF mode (When the compressor off by the thermoregulating) 2-4. Cool air prevention mode (Defrosting mode) 2-5. Capacity increasing mode</p>	
	<p>2-1. Hot adjuster mode The fan controller becomes the hot adjuster mode for the following conditions.</p> <ol style="list-style-type: none"> ① When starting the HEAT operation ② When the thermoregulating function changes from OFF to ON. ③ When release the HEAT defrosting operation <p>A: HOT adjuster mode start B: 5 min have passed since the condition A or the indoor liquid pipe temperature turned 65°F or more C: 2 min have passed since the condition A (Terminating the hot adjuster mode)</p>	<p>*1 "STAND BY" will be displayed during the hot adjuster mode.</p>
	<p>2-2. Preheating exclusion mode When the condition changes the auxiliary heater ON to OFF (thermoregulating or operation stop, etc), the indoor fan operates in [Low] mode for 1 minute.</p>	<p>*1 This control is same for the model without auxiliary heater.</p>

To be continued on the next page.

From the preceding page.

Control modes	Control details	Remarks
2. Fan	2-3. Thermo OFF mode When the thermoregulating function changes to OFF, the indoor fan operates in [Extra low].	
	2-4. Heat defrosting mode The indoor fan stops.	
3. Drain pump	No drain pump operation However, when the control changes from COOL or DRY operation, the drain pump operates for 3 minutes.	
4. Vane control (Up/ down vane change)	(1) Initial setting : OFF → HEAT...[last setting] When changing the mode from exception of HEAT to HEAT operation. ...[Downward C] (2) Vane position : Horizontal →Downward A →Downward B →Downward C→Swing (3) Restriction of vane position ① The vane is horizontally fixed for the following modes. (The control by the remote controller is temporally invalidated and control by the unit.) •Thermo OFF •Hot adjuster [Extra low] mode •Heat defrost mode	

8-5. AUTO operation [Automatic COOL/HEAT change over operation]

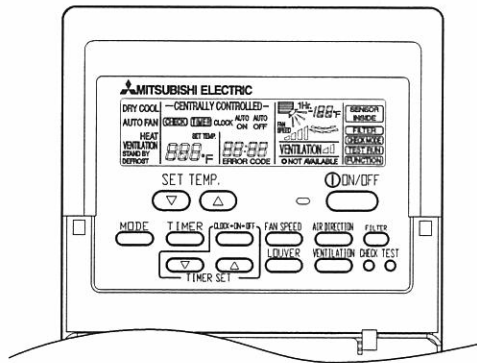

<How to operate>

- ① Press POWER ON/OFF button.
- ② Press the operation MODE button to display AUTO.
- ③ Press the SET TEMP. button to set the desired temperature.

NOTE: The set temperature changes 2°F when the ∇ or Δ button is pressed one time. Automatic 67 to 83°F.

“AUTO” works to change by itself the operation mode either to cooling or heating to the room temperature.

Control modes	Control details	Remarks
1. Initial value of operation mode	HEAT mode for room temperature < Desired temperature COOL mode for room temperature \geq Desired temperature	
2. Mode change	(1) HEAT mode \rightarrow COOL mode Room temperature \geq Desired temperature + 4°F. or 15 min. has passed (2) COOL mode \rightarrow HEAT mode Room temperature \leq Desired temperature - 4°F. or 15 min. has passed	
3. COOL mode	Same control as cool operation	
4. HEAT mode	Same control as heat operation	

8-6. When unit is stopped Control mode

Control modes	Control details	Remarks
1. Drain pump	<p>1-1. Drain pump control</p> <p>The drain pump turns ON for the specified amount of time when any of the following conditions is met (regardless of whether the compressor is ON or OFF)</p> <ol style="list-style-type: none"> ① ON for 3 minutes after the operation mode is switched from COOL or DRY to another operation mode (HEAT mode). ② ON for 6 minutes after the drain sensor is determined to be submerged using the liquid level detection method given below. ③ ON for 6 minutes after indoor piping (liquid piping) temperature – indoor intake temperature \leq -18°F, AND the drain sensor input is at the short or open level. (If condition ② or ③ is still being met after the drain pump has been turned ON for 6 minutes, the drain pump is kept ON for a further 6 minutes.) 	
	<p>1-2. Liquid level detection method</p> <p>The liquid level is detected by determining whether or not the drain sensor is submerged, based on the amount the temperature rises after self-heating the sensor. This process is performed if any of the following conditions is met:</p> <ol style="list-style-type: none"> ① Drain pump is ON. ② Indoor piping (liquid piping) temperature – indoor intake temperature \leq -18°F (except during defrosting) ③ Indoor piping (liquid piping) temperature or indoor intake temperature is at the short or open level temperature. ④ Every hour after the drain pump has been switched from ON to OFF. 	

8-7. TIMER operation

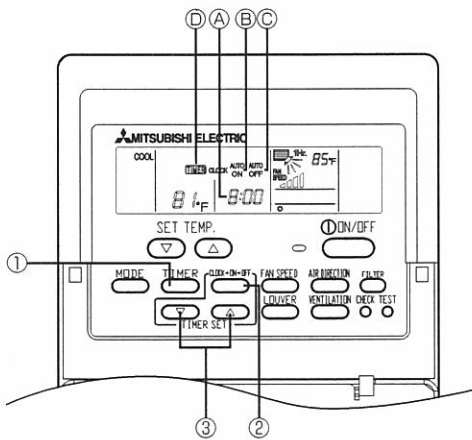
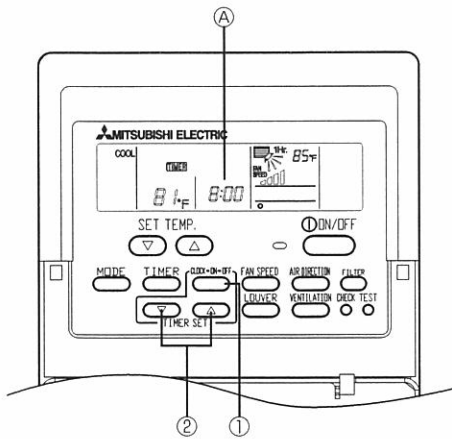

1) Set the current time

- ① Press CLOCK-ON-OFF button to display the "current time" ①.

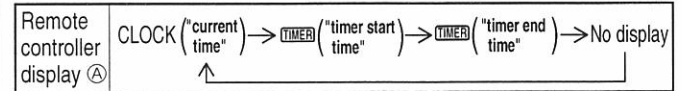

- ② Each time you press button, the time increases in increments of one minute. Each time you press button, the time decreases in increments of one minute.

- Press and hold the button to rapidly change the time.
- The time changes in increments of one minute → ten minutes → in units of hour; in this order.

- Approximately ten seconds after pressing the button, the display on the remote controller will turn off.

The example shows a timer set for operation start at 8:00 and end at 17:00.

2) set the mode to continuous as follows

- ① Press TIMER button to display ①.

3) Set the time to start the unit as follows

- ② Press CLOCK-ON-OFF button to display ② ON.

- ③ Press button to set the time that you want the unit to start. The start time is displayed at ③.

4) Set the time to stop the unit as follows

- ② Press CLOCK-ON-OFF button to display ③ OFF.

- ③ Press button to set the time that you want the unit to stop. The stop time is displayed at ④.

5) Set the mode to timer as follows

- ① Press TIMER button to display ①.

9

TROUBLE SHOOTING

9-1. How to check the parts PLFY-12, 20, 24, 32, 40NAMU-A

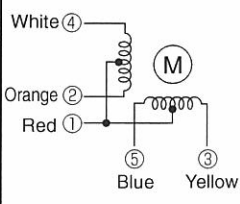
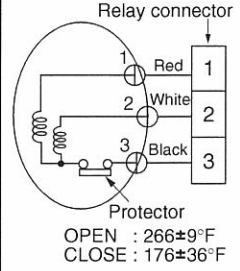
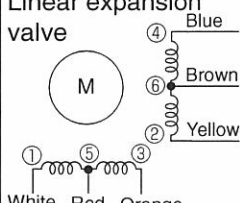
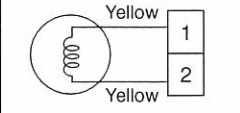
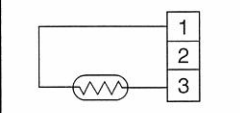
Parts name	Check points																		
Room temperature thermistor (TH21) Liquid pipe thermistor (TH22) Gas pipe thermistor (TH23)	Disconnect the connector then measure the resistance using a tester. (Surrounding temperature 50°F~86°F) <table border="1" style="margin-left: 20px;"> <tr> <th>Normal</th> <th>Abnormal</th> </tr> <tr> <td>4.3kΩ~9.6kΩ</td> <td>Open or short</td> </tr> </table> (Refer to the next page for a detail.)	Normal	Abnormal	4.3kΩ~9.6kΩ	Open or short														
Normal	Abnormal																		
4.3kΩ~9.6kΩ	Open or short																		
Vane motor 	Measure the resistance between the terminals using a tester. (Surrounding temperature 68°F~86°F) <table border="1" style="margin-left: 20px;"> <tr> <th>Connector</th> <th>Normal</th> <th>Abnormal</th> </tr> <tr> <td>Red — Yellow</td> <td rowspan="5">300Ω</td> <td rowspan="5">Open or short</td> </tr> <tr> <td>Red — Blue</td> </tr> <tr> <td>Red — Orange</td> </tr> <tr> <td>Red — White</td> </tr> <tr> <td>Red — Blue</td> </tr> </table>	Connector	Normal	Abnormal	Red — Yellow	300Ω	Open or short	Red — Blue	Red — Orange	Red — White	Red — Blue								
Connector	Normal	Abnormal																	
Red — Yellow	300Ω	Open or short																	
Red — Blue																			
Red — Orange																			
Red — White																			
Red — Blue																			
Fan motor  <p>Relay connector</p> <p>Protector OPEN : 266±9°F CLOSE : 176±36°F</p>	Measure the resistance between the terminals using a tester. <table border="1" style="margin-left: 20px;"> <tr> <th rowspan="2">Motor terminal or Relay connector</th> <th colspan="2">Normal</th> <th rowspan="2">Abnormal</th> </tr> <tr> <th colspan="2">PLFY-NAMU-A</th> </tr> <tr> <td></td> <td>12, 20, 24</td> <td>32, 40</td> <td rowspan="3">Open or short</td> </tr> <tr> <td>Red-Black</td> <td>87.2Ω</td> <td>32.6Ω</td> </tr> <tr> <td>White-Black</td> <td>104.1Ω</td> <td>40.7Ω</td> </tr> </table>	Motor terminal or Relay connector	Normal		Abnormal	PLFY-NAMU-A			12, 20, 24	32, 40	Open or short	Red-Black	87.2Ω	32.6Ω	White-Black	104.1Ω	40.7Ω		
Motor terminal or Relay connector	Normal		Abnormal																
	PLFY-NAMU-A																		
	12, 20, 24	32, 40	Open or short																
Red-Black	87.2Ω	32.6Ω																	
White-Black	104.1Ω	40.7Ω																	
Linear expansion valve 	Disconnect the connector then measure the resistance valve using a tester. <table border="1" style="margin-left: 20px;"> <tr> <th colspan="4">Normal</th> <th rowspan="2">Abnormal</th> </tr> <tr> <th>① - ⑤</th> <th>② - ⑥</th> <th>③ - ⑤</th> <th>④ - ⑥</th> </tr> <tr> <td>White-Red</td> <td>Yellow-Brown</td> <td>Orange-Red</td> <td>Blue-Brown</td> <td rowspan="2">Open or short</td> </tr> <tr> <td colspan="4" style="text-align: center;">150Ω ±10%</td> </tr> </table> (Refer to the next page for a detail.)	Normal				Abnormal	① - ⑤	② - ⑥	③ - ⑤	④ - ⑥	White-Red	Yellow-Brown	Orange-Red	Blue-Brown	Open or short	150Ω ±10%			
Normal				Abnormal															
① - ⑤	② - ⑥	③ - ⑤	④ - ⑥																
White-Red	Yellow-Brown	Orange-Red	Blue-Brown	Open or short															
150Ω ±10%																			
Drain pump 	Measure the resistance between the terminals using a tester. (Surrounding temperature 68°F~86°F) <table border="1" style="margin-left: 20px;"> <tr> <th>Normal</th> <th>Abnormal</th> </tr> <tr> <td>319Ω</td> <td>Open or short</td> </tr> </table>	Normal	Abnormal	319Ω	Open or short														
Normal	Abnormal																		
319Ω	Open or short																		
Drain sensor 	Measure the resistance after 3 minutes have passed since the power supply was intercepted. (Surrounding temperature 50°F~140°F) <table border="1" style="margin-left: 20px;"> <tr> <th>Normal</th> <th>Abnormal</th> </tr> <tr> <td>0.6kΩ~6.0kΩ</td> <td>Open or short</td> </tr> </table> (Refer to the next page for a detail.)	Normal	Abnormal	0.6kΩ~6.0kΩ	Open or short														
Normal	Abnormal																		
0.6kΩ~6.0kΩ	Open or short																		

<Thermistor characteristic graph>

Thermistor for lower temperature

Room temperature thermistor(TH21)
Liquid pipe temperature thermistor(TH22)
Gas pipe temperature thermistor(TH23)

Thermistor $R_0=15k\Omega \pm 3\%$
Fixed number of $B=3480k\Omega \pm 2\%$

$$R_t=15 \exp \left\{ 3480 \left(\frac{1}{273+(t-32)/1.8} - \frac{1}{273} \right) \right\}$$

30°F	15.8kΩ
50°F	9.6kΩ
70°F	6.0kΩ
80°F	4.8kΩ
90°F	3.9kΩ
100°F	3.2kΩ

Thermistor for drain sensor

Thermistor $R_0=6.0k\Omega \pm 5\%$
Fixed number of $B=3390k\Omega \pm 2\%$

$$R_t=6 \exp \left\{ 3390 \left(\frac{1}{273+(t-32)/1.8} - \frac{1}{273} \right) \right\}$$

30°F	6.3kΩ
50°F	3.9kΩ
70°F	2.5kΩ
80°F	2.0kΩ
90°F	1.6kΩ
100°F	1.3kΩ

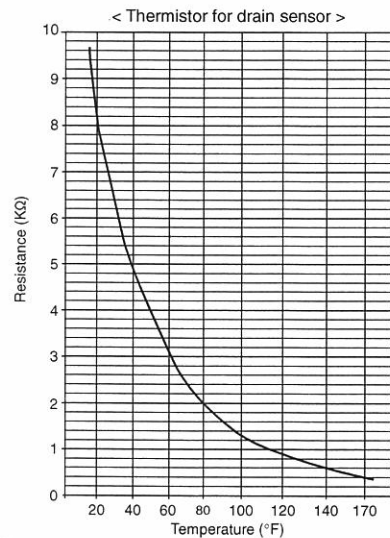
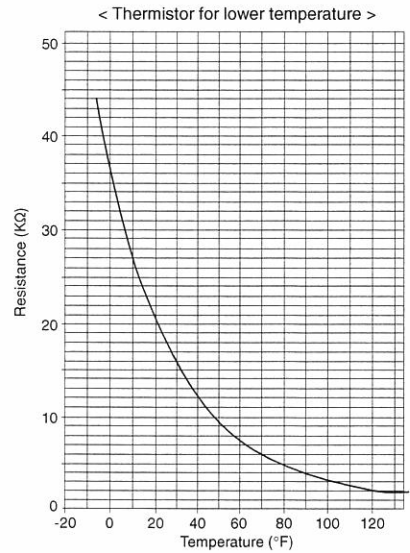

Linear expansion valve

① Operation summary of the linear expansion valve.

- Linear expansion valve open/close through stepping motor after receiving the pulse signal from the indoor controller board.
- Valve position can be changed in proportion to the number of pulse signal.

<Connection between the indoor controller board and the linear expansion valve>

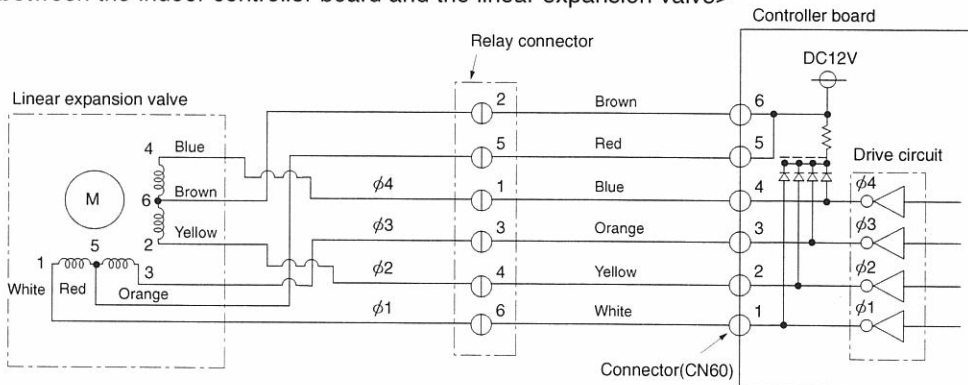

Note : Since the number of the connector at the controller board side and the relay connector are different, follow the color of the lead wire.

<Output pulse signal and the valve operation>

Output (Phase)	Output			
	1	2	3	4
φ1	ON	OFF	OFF	ON
φ2	ON	ON	OFF	OFF
φ3	OFF	ON	ON	OFF
φ4	OFF	OFF	ON	ON

Closing a valve : 1 → 2 → 3 → 4 → 1
 Opening a valve : 4 → 3 → 2 → 1 → 4

The output pulse shifts in above order.

- * 1. When linear expansion valve operation stops, all output phase become OFF.
- 2. At phase interruption or when phase does not shift in order, motor does not rotate smoothly and motor will lock and vibrates.

② Linear expansion valve operation

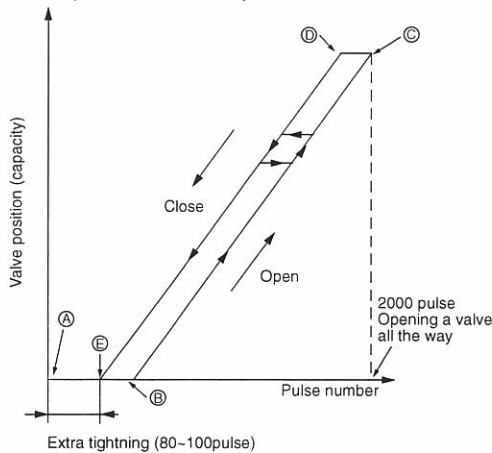

- * When the switch is turned on, 2200 pulse closing valve signal will be send till it goes to A point in order to define the valve position.







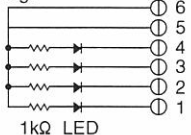
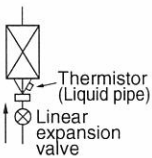













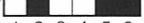









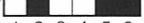





When the valve moves smoothly, there is no noise or vibration occurring from the linear expansion valve : however, when the pulse number moves from E to A or when the valve is locked, more noise can be heard than normal situation.

- * Noise can be detected by placing the ear against the screw driver handle while putting the screw driver to the linear expansion valve.

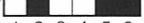
③ Trouble shooting

Symptom	Check points	Countermeasures
Operation circuit failure of the micro processor.	Disconnect the connector on the controller board, then connect LED for checking.  Pulse signal will be sent out for 10 seconds as soon as the main switch is turn on. If there is LED with lights on or lights off, it means the operation circuit is abnormal.	Exchange the indoor controller board at drive circuit failure.
Linear expansion valve mechanism is locked.	Motor will idle and make ticking noise when motor is operated while the linear expansion valve is locked. This ticking sound is the sign of the abnormality.	Exchange the linear expansion vale.
Short or breakage of the motor coil of the linear expansion valve.	Measure the resistance between the each coil (red-white, red-orange, brown-yellow, brown-blue) using a tester. It is normal if the resistance is in the range of $150\Omega \pm 10\%$.	Exchange the linear expansion valve.
Valve doesn't close completely (thermistor leaking).	To check the linear expansion valve, operate the indoor unit in fan mode and at the same time operate other indoor units in cooling mode, then check the pipe temperature <liquid pipe temperature> of the indoor unit by the outdoor multi controller board operation monitor. During fan operation, linear expansion valve is closed completely and if there are some leaking, detecting temperature of the thermistor will go lower. If the detected temperature is much lower than the temperature indicated in the remote controller, it means the valve is not closed all the way. It is not necessary to exchange the linear expansion valve, if the leakage is small and not making any trouble. 	If large amount of thermistor is leaked, exchange the linear expansion valve.
Wrong connection of the connector or contact failure.	Check the color of lead wire and missing terminal of the connector.	Disconnect the connector at the controller board, then check the continuity.

9-2. FUNCTION OF DIP SWITCH

Switch	Pole	Function	Operation by switch		Remarks																	
			ON	OFF																		
SW1 Mode Selection	1	Thermistor <intake temperature detection> position	Built-in remote controller	Indoor unit	<div style="border: 1px solid black; padding: 2px; display: inline-block;">Address board</div> <At delivery> ON  OFF  1 2 3 4 5 6 7 8 9 10 Note : ※1 Fan operation at Heating mode. ※2 Heater thermo ON is operating. ※3 SW 1-7=OFF, SW 1-8=ON → Setting air flow. SW 1-7=ON, SW 1-8=ON → Indoor fan stop.																	
	2	Filter clogging detection	Provided	Not provided																		
	3	Filter cleaning	2,500hr	100hr																		
	4	Fresh air intake	Effective	Not effective																		
	5	Remote indication switching	Thermostat ON signal indication	Fan output indication																		
	6	Humidifier control	Always operated while the heat in ON ※1	Operated depends on the condition ※2																		
	7	Air flow set in case of	Low ※3	Extra low ※3																		
	8	Heat thermostat OFF	Setting air flow ※3	Depends on SW1-7																		
	9	Auto restart function	Effective	Not effective																		
	10	Power ON/OFF	Effective	Not effective																		
SW2 Capacity code setting	1~6	<table border="1" style="width: 100%; text-align: center;"> <thead> <tr> <th>MODELS</th> <th>SW 2</th> <th>MODELS</th> <th>SW 2</th> </tr> </thead> <tbody> <tr> <td>PLFY-12NAMU-A</td> <td>ON  OFF  1 2 3 4 5 6</td> <td>PLFY-32NAMU-A</td> <td>ON  OFF  1 2 3 4 5 6</td> </tr> <tr> <td>PLFY-20NAMU-A</td> <td>ON  OFF  1 2 3 4 5 6</td> <td>PLFY-40NAMU-A</td> <td>ON  OFF  1 2 3 4 5 6</td> </tr> <tr> <td>PLFY-24NAMU-A</td> <td>ON  OFF  1 2 3 4 5 6</td> <td></td> <td></td> </tr> </tbody> </table>				MODELS	SW 2	MODELS	SW 2	PLFY-12NAMU-A	ON  OFF  1 2 3 4 5 6	PLFY-32NAMU-A	ON  OFF  1 2 3 4 5 6	PLFY-20NAMU-A	ON  OFF  1 2 3 4 5 6	PLFY-40NAMU-A	ON  OFF  1 2 3 4 5 6	PLFY-24NAMU-A	ON  OFF  1 2 3 4 5 6			<div style="border: 1px solid black; padding: 2px; display: inline-block;">Indoor controller board</div> Set while the unit is off. <At delivery> Set for each capacity.
		MODELS	SW 2	MODELS	SW 2																	
		PLFY-12NAMU-A	ON  OFF  1 2 3 4 5 6	PLFY-32NAMU-A	ON  OFF  1 2 3 4 5 6																	
		PLFY-20NAMU-A	ON  OFF  1 2 3 4 5 6	PLFY-40NAMU-A	ON  OFF  1 2 3 4 5 6																	
PLFY-24NAMU-A	ON  OFF  1 2 3 4 5 6																					
1	Heat pump / Cooling only	Cooling only	Heat pump	<div style="border: 1px solid black; padding: 2px; display: inline-block;">Indoor controller board</div> Set while the unit is off. <At delivery> ON  OFF  1 2 3 4 5 6 7 8 9 10 Note : ※4 At cooling mode, each angle can be used only 1 hour. ※5 SW3-2 setting Only for PLFY-NAM, SW is used to change whether the humidifier functions or not. (Fixed the louver function less.) ※6 SW3-9 setting PLFY-12NAMU-A = ON 20NAMU-A = ON 24NAMU-A = OFF 32NAMU-A = ON 40NAMU-A = OFF																		
2	Louver / humidifier ※5	Available	Not available																			
3	Vane	Available	Not available																			
4	Vane swing function	Available	Not available																			
5	Vane horizontal angle	Second setting	First setting																			
6	Vane cooling limit angle setting ※4	Horizontal angle	Down B, C																			
7	Indoor linear expansion valve opening	Effective	Not effective																			
8	Heat 4degrees up	Not effective	Effective																			
9	Superheat setting temperature ※6	5degrees	2degrees																			
10	Sub cool setting temperature	15degrees	10degrees																			
SW4 Unit Selection	1~5	ON  OFF  1 2 3 4 5			<div style="border: 1px solid black; padding: 2px; display: inline-block;">Indoor controller board</div> Set while the unit is off. <At delivery> ON  OFF  1 2 3 4 5																	

Switch	Pole	Operation by switch	Remarks																									
SWA Ceiling height selector	1~3	<p>(High ceiling^②) 3</p> <p>(High ceiling^①) 2</p> <p>(Standard) 1</p> <p>* Ceiling height can be changed depends on SWB setting.</p> <p>PLFY-12, 20, 24NAMU-A (Unit : feet)</p> <table border="1"> <thead> <tr> <th colspan="2" rowspan="2"></th> <th colspan="3">SWA</th> </tr> <tr> <th>1</th> <th>2</th> <th>3</th> </tr> </thead> <tbody> <tr> <th rowspan="4">SWB</th> <th>Standard</th> <td></td> <td>High ceiling^①</td> <td>High ceiling^②</td> </tr> <tr> <th>4 4 direction</th> <td>8.9</td> <td>9.8</td> <td>11.5</td> </tr> <tr> <th>3 3 direction</th> <td>9.8</td> <td>10.8</td> <td>11.5</td> </tr> <tr> <th>2 2 direction</th> <td>10.8</td> <td>11.5</td> <td>—</td> </tr> </tbody> </table>			SWA			1	2	3	SWB	Standard		High ceiling ^①	High ceiling ^②	4 4 direction	8.9	9.8	11.5	3 3 direction	9.8	10.8	11.5	2 2 direction	10.8	11.5	—	<p>Address board</p> <p><At delivery></p>
		SWA																										
		1	2	3																								
SWB	Standard		High ceiling ^①	High ceiling ^②																								
	4 4 direction	8.9	9.8	11.5																								
	3 3 direction	9.8	10.8	11.5																								
	2 2 direction	10.8	11.5	—																								
SWB Discharge outlet number selector	3	<p>(2 direction) 2</p> <p>(3 direction) 3</p> <p>(4 direction) 4</p> <p>PLFY-32, 40NAMU-A (Unit : feet)</p> <table border="1"> <thead> <tr> <th colspan="2" rowspan="2"></th> <th colspan="3">SWA</th> </tr> <tr> <th>1</th> <th>2</th> <th>3</th> </tr> </thead> <tbody> <tr> <th rowspan="4">SWB</th> <th>Standard</th> <td></td> <td>High ceiling^①</td> <td>High ceiling^②</td> </tr> <tr> <th>4 4 direction</th> <td>10.5</td> <td>11.8</td> <td>13.8</td> </tr> <tr> <th>3 3 direction</th> <td>11.8</td> <td>13.1</td> <td>13.8</td> </tr> <tr> <th>2 2 direction</th> <td>13.1</td> <td>13.8</td> <td>—</td> </tr> </tbody> </table>			SWA			1	2	3	SWB	Standard		High ceiling ^①	High ceiling ^②	4 4 direction	10.5	11.8	13.8	3 3 direction	11.8	13.1	13.8	2 2 direction	13.1	13.8	—	<p>Address board</p> <p><At delivery></p>
		SWA																										
		1	2	3																								
SWB	Standard		High ceiling ^①	High ceiling ^②																								
	4 4 direction	10.5	11.8	13.8																								
	3 3 direction	11.8	13.1	13.8																								
	2 2 direction	13.1	13.8	—																								
SWC Option selector	2	<p>Option</p> <p>Standard</p> <p>When attach the optional high performance filter elements (multi function casement) to the unit, be sure to attach it to the option side in order to prevent the airflow reducing.</p>	<p>Address board</p> <p><At delivery></p> <p>Option</p> <p>Standard</p>																									
SW11 1st digit address setting	Rotary switch	<p>SW12 SW11</p> <p>10 1</p> <p>Address setting should be done when M-NET Remote controller is being used.</p>	<p>Address board</p> <p>Address can be set while the unit is stopped.</p> <p><At delivery></p>																									
SW12 2nd digit address setting																												
SW14 Connection No. setting	Rotary switch	<p>SW14</p> <p>This is the switch to be used when the indoor unit is operated with R2 series outdoor unit as a set.</p>	<p>Address board</p> <p><At delivery></p> <p>SW14</p>																									
SW5 Voltage Selection	2	<p>220V (208V) 240V (230V)</p> <p>If the unit is used at the 230V area, set the voltage to 230V.</p> <p>If the unit is used at the 208V, set the voltage to 208V.</p>	<p>Address board</p> <p><At delivery></p> <p>220V (208V) 240V (230V)</p>																									

PLFY-20NAMU-A

Be careful on removing heavy parts.

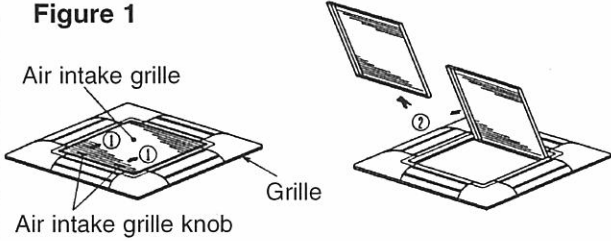
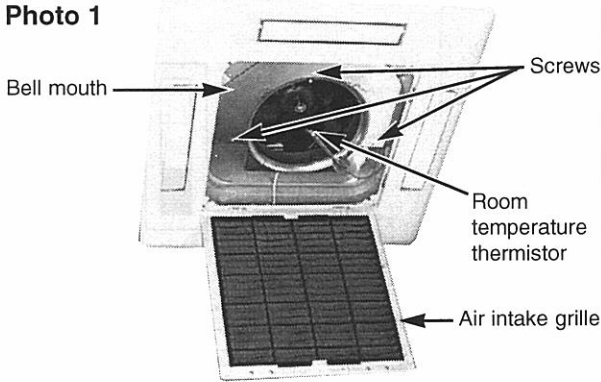
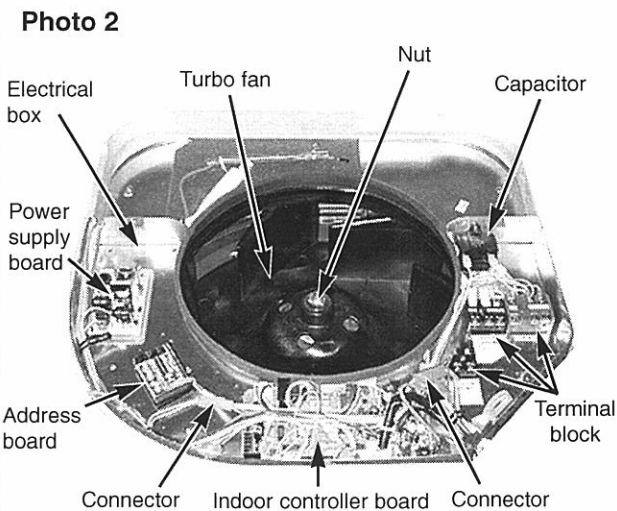
OPERATING PROCEDURE	PHOTOS&ILLUSTRATIONS
<p>1. Removing the air intake grille</p> <p>(1) Slide the knob of air intake grille to the direction of the arrow ① to open the air intake grille.</p> <p>(2) Remove the string hook from the panel to prevent the grille from dropping.</p> <p>(3) Slide the shaft in the hinge to the direction of the arrow② and remove the air intake grille.</p>	<p>Figure 1</p>  <p>Air intake grille knob</p> <p>Grille</p>
<p>2. Removing the room temperature thermistor</p> <p>(1) Remove the screw(X1) in the room temperature thermistor holder to remove the holder and the room temperature thermistor.</p> <p>(2) Remove the 1 screw from the bell mouth, and unscrew the another 2 screws (fixed to the oval hole which has different diameter) to remove the bell mouth.</p> <p>(3) Hold the holder claw, and remove the room temperature thermistor and holder.</p> <p>(4) Disconnect the connector (red) in the indoor control board.</p>	<p>Photo 1</p>  <p>Bell mouth</p> <p>Screws</p> <p>Room temperature thermistor</p> <p>Air intake grille</p>
<p>3. Removing the electrical box</p> <p>(1) Disconnect the lead wire of the vane motor from the clamp, and disconnect the white connector (10P).</p> <p>(2) Remove the room temperature thermistor with the holder.</p> <p>(3) Remove the bell mouth.(See photo 1)</p> <p>(4) Disconnect the relay connector in the electrical box.</p> <p>Red (3P) for fan motor power supply White (2P) for pipe temperature detection / liquid thermistor Black (2P) for pipe temperature detection / gas thermistor Blue (2P) for drain pump White (3P) for drain sensor</p> <p>(5) Remove the 3 screws from the electrical box, loosen another 2 screws to remove the box.</p> <p><Electrical parts in the electrical box></p> <p>Indoor controller board power supply board Terminal block (Power supply) Terminal block (Transmission) Terminal block (MA remote controller) Capacitor Address board</p>	<p>Photo 2</p>  <p>Electrical box</p> <p>Turbo fan</p> <p>Nut</p> <p>Capacitor</p> <p>Power supply board</p> <p>Address board</p> <p>Indoor controller board</p> <p>Terminal block</p> <p>Connector</p>

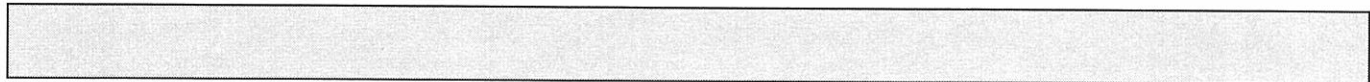

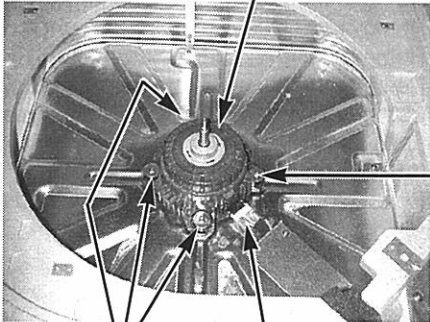
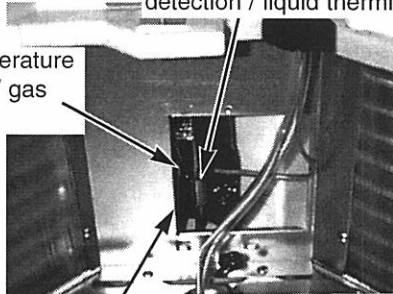
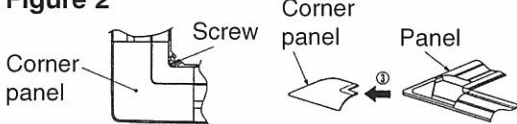
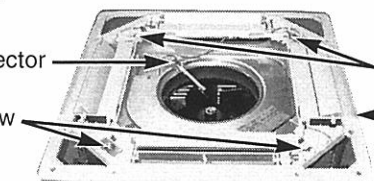
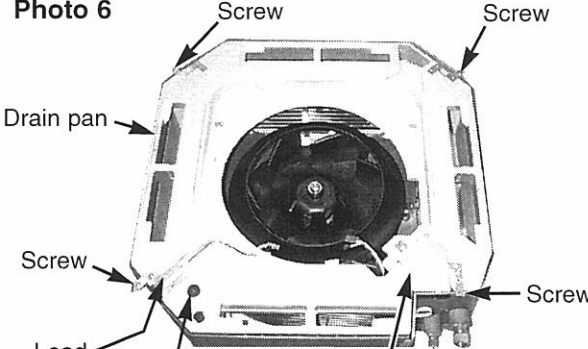
OPERATING PROCEDURE	PHOTOS&ILLUSTRATIONS
<p>4. Remove the fan motor</p> <ol style="list-style-type: none">(1) Remove the bell mouth.(See photo 1)(2) Remove the electrical box.(See photo 2)(3) Remove the turbo fan nut, washer and radiation cap(P100, P125).(4) Pull out the turbo fan.(5) Disconnect the connector of the fan motor lead wire.(6) Remove the 4 nuts of the fan motor.	<p>Photo 3</p>  <p>Fan motor</p> <p>Nut</p> <p>Nut</p> <p>Connector</p>
<p>5. Removing the pipe temperature detection / liquid thermistor and the pipe temperature detection / gas thermistor</p> <ol style="list-style-type: none">(1) Remove the bell mouth.(See photo 1)(2) Remove the electrical box.(See photo 2)(3) Remove the turbo fan.(4) Remove the screw of the service panel.(5) Remove the service panel.(6) Remove the pipe temperature detection / liquid thermistor and the pipe temperature detection / gas thermistor which is inserted into the holder installed to the thin copper pipe.(7) Disconnect the each 2-pin white(liquid) and black(gas) connector.	<p>Photo 4</p>  <p>Pipe temperature detection / liquid thermistor</p> <p>Pipe temperature detection / gas thermistor</p> <p>Service entrance</p>
<p>6. Removing the panel</p> <ol style="list-style-type: none">(1) Remove the air intake grille.(See figure 1) <p>Corner panel (See figure 2)</p> <ol style="list-style-type: none">(1) Remove the screw of the corner.(2) Slide the corner panel to the direction of the arrow③, and remove the corner panel. <p>Panel (See photo 6)</p> <ol style="list-style-type: none">(1) Disconnect the connector that connects with the unit.(2) Remove the 2 screws from the panel and loose another 2 screws, which fixed to the oval hole, have different diameter.(3) Rotate the panel a little to remove the screws.(Slide the panel so that the screw comes to a large diameter of the oval hole, which has two different diameters.)	<p>Figure 2</p>  <p>Corner panel</p> <p>Screw</p> <p>Panel</p> <p>Photo 5</p>  <p>Connector</p> <p>Screw</p> <p>Screw</p> <p>Panel</p>
<p>7. Removing the drain pan</p> <ol style="list-style-type: none">(1) Remove the panel. (See photo 5)(2) Remove the drain plug (Larger one), drain the remaining water in the drain pan.(3) Remove the corner cover. (2 screws)(4) Remove the bell mouth (See photo 1)(5) Remove the electrical box. (See photo 2)(6) Remove the lead wire holder. (1 screw)(7) Remove the 4 screws and pull out the drain pan. <p>* Pull out the left and right of the pan gradually. Be careful not to crack or damage the pan.</p>	<p>Photo 6</p>  <p>Screw</p> <p>Screw</p> <p>Drain pan</p> <p>Screw</p> <p>Lead wire holder</p> <p>Drain plug(Larger one)</p> <p>Corner cover</p>

OPERATING PROCEDURE

PHOTOS&ILLUSTRATIONS

8. Removing the drain pump and drain sensor

- (1) Remove the panel. (See photo 5)
- (2) Remove the bell mouth. (See photo 1)
- (3) Remove the electrical box. (See photo 2)
- (4) Remove the drain pan. (See photo 6)
- (5) Remove the 3 screws of the drain pump.
- (6) Cut the drain hose band, pull out the drain hose from the drain pump.
- (7) Pull out the drain pump.
- (8) Remove the drain sensor and the holder.

Photo 7

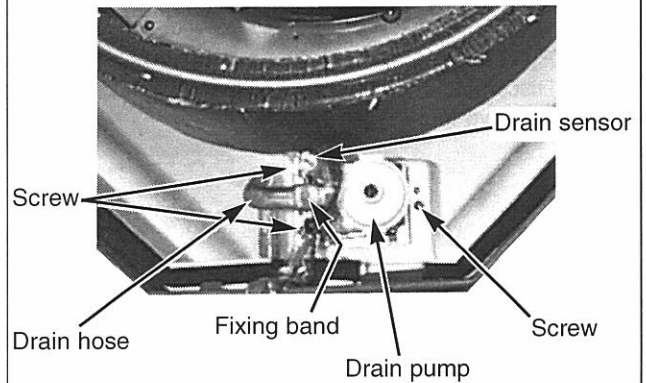

9. Removing the heat exchanger

- (1) Remove the panel. (See photo 5)
- (2) Remove the bell mouth. (See photo 1)
- (3) Remove the electrical box. (See photo 2)
- (4) Remove the drain pan. (See photo 6)
- (5) Remove the turbo fan. (See photo 3)
- (6) Remove the 3 screws of the piping cover, and pull out piping cover.
- (7) Remove the 4 screws of the outer wall cover, and pull out the outer wall cover.
- (8) Remove the screw of the coil support.
- (9) Remove the 2 screws of the coil.
- (10) Pull out the heat exchanger.

Photo 8

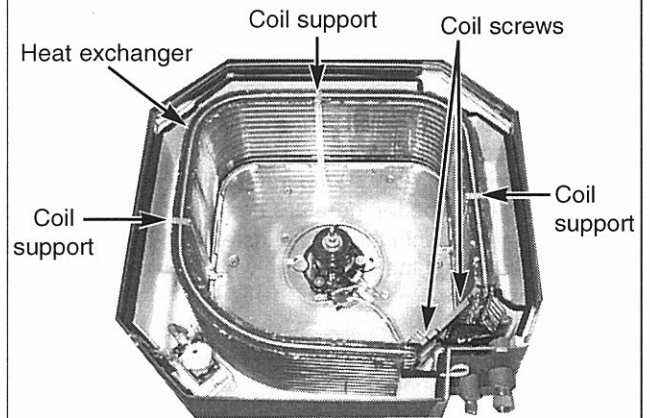
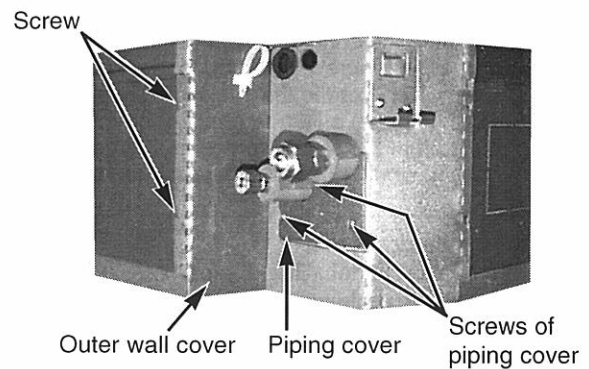

Photo 9



11

PARTS LIST

PANEL PARTS
 PLFY-12NAMU-A
 PLFY-20NAMU-A
 PLFY-24NAMU-A
 PLFY-32NAMU-A
 PLFY-40NAMU-A

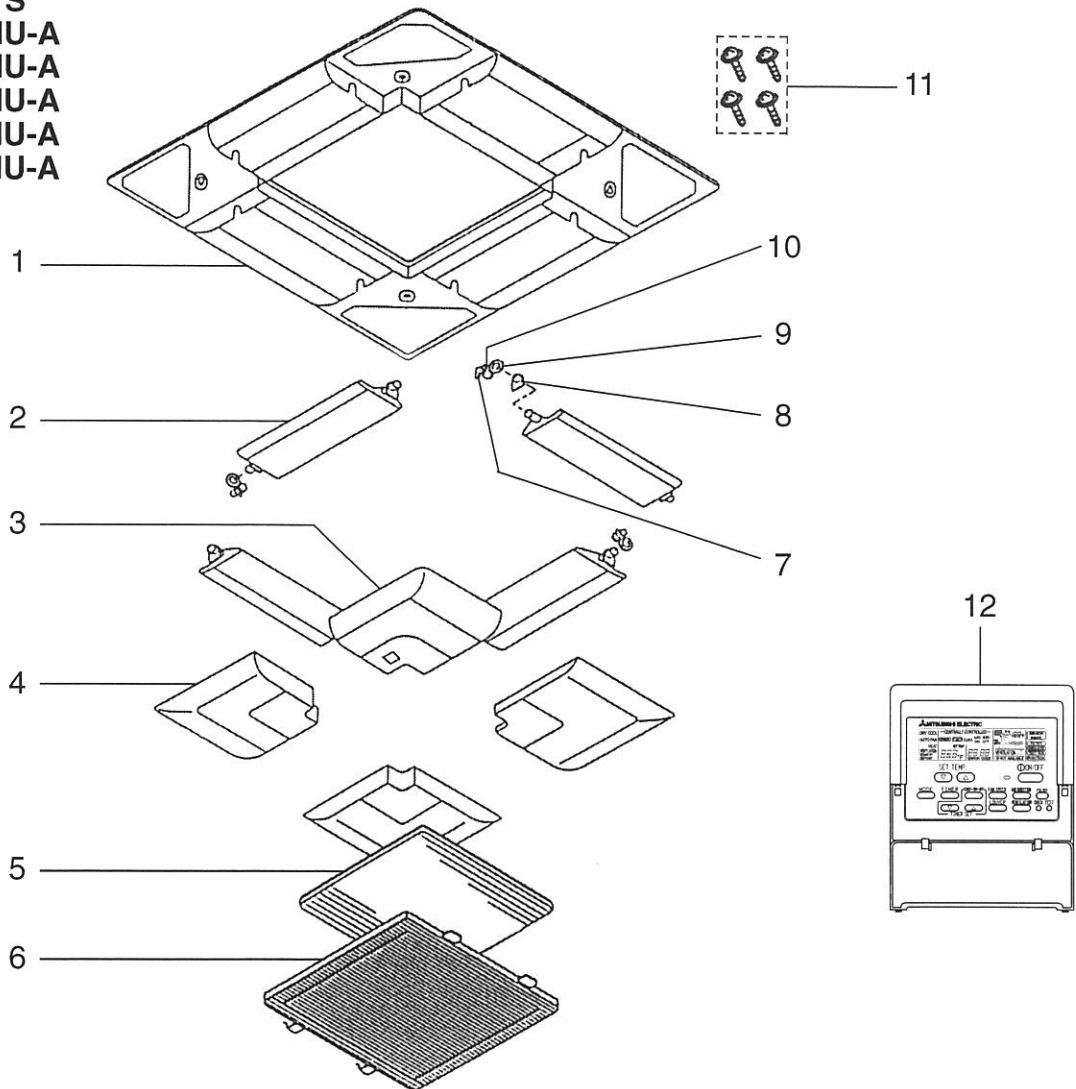

No.	Part No.	Part Name	Specification	Q'ty/set		Remarks (Drawing No.)	Wiring Diagram Symbol	Recom- mended Q'ty	Price	
				PLFY- 12, 20, 24, 32, 40 NAMU-A					Unit	Amount
1	T7W E12 003	AIR OUTLET GRILLE	PLP-40AAU	1						
2	T7W E05 002	AUTO VANE		4						
3	T7W E01 638	CORNER PANEL		1						
4	R01 E00 638	CORNER PANEL		3						
5	R01 E00 500	AIR FILTER		1						
6	R01 E00 691	GRILLE ASSY		1						
7	R01 E00 223	VANE MOTOR		4		MV				
8	R01 E00 063	VANE BUSH		8						
9	R01 E00 040	GEAR (VANE)		4						
10	R01 E01 040	GEAR (MOTOR)		4						
11	T7W E00 673	SCREW ASSY		1						
12	—	REMOTE CONTROLLER	PAR-20MAU	1		R.B				

This REMOTE CONTROLLER is made by AIR-CONDITIONING & REFRIGERATION SYSTEMS WORKS, MITSUBISHI ELECTRIC CORPORATION.

FUNCTIONAL PARTS
PLFY-12NAMU-A
PLFY-20NAMU-A
PLFY-24NAMU-A
PLFY-32NAMU-A
PLFY-40NAMU-A

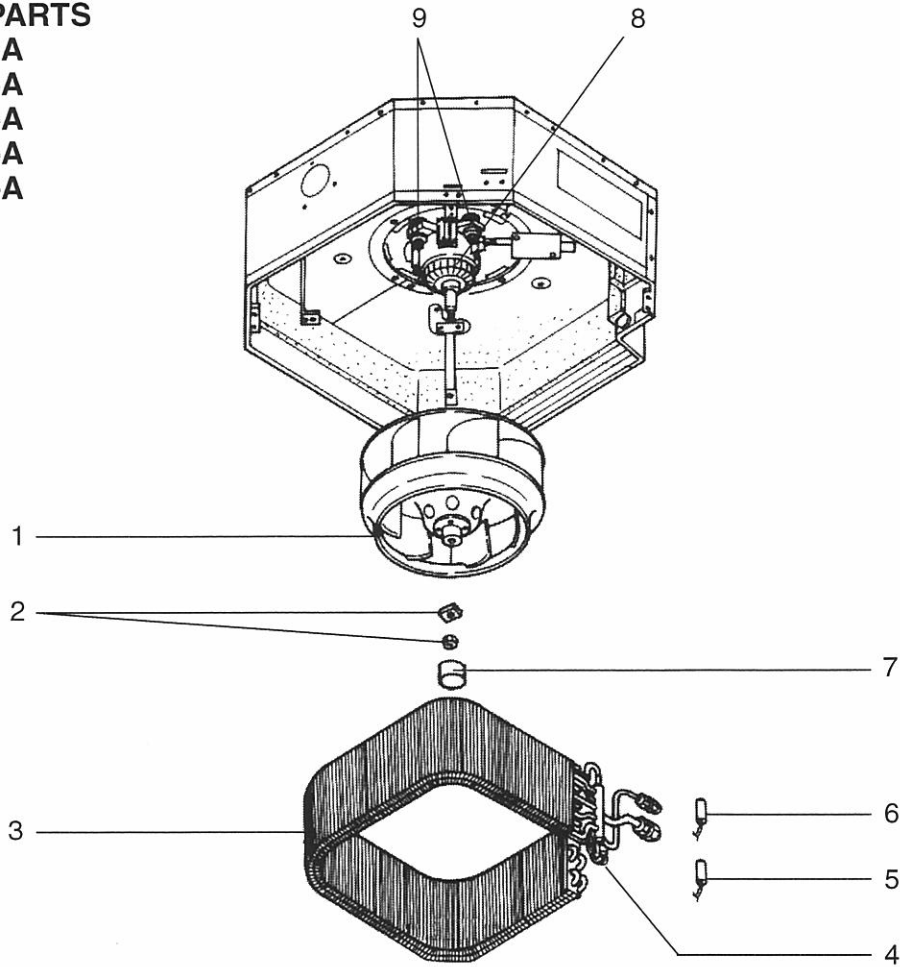

No.	Part No.	Part Name	Specification	Q'ty/set					Remarks (Drawing No.)	Wiring Diagram Symbol	Recom- mended Q'ty	Price	
				PLFY- - NAMU-A								Unit	Amount
				12	20	24	32	40					
1	R01 E10 114	TURBO FAN		1	1	1							
	R01 E11 114	TURBO FAN					1	1					
2	R01 08K 097	SPL WASHER		1	1	1	1	1					
3	T7W E92 480	HEAT EXCHANGER		1									
	T7W E93 480	HEAT EXCHANGER			1								
	T7W E94 480	HEAT EXCHANGER				1							
	T7W E95 480	HEAT EXCHANGER					1						
	T7W E96 480	HEAT EXCHANGER						1					
4	T7W E11 401	LINEAR EXPANSION VALVE		1	1	1			LEV				
	R01 E32 401	LINEAR EXPANSION VALVE					1	1	LEV				
5	T7W E06 202	PIPE TEMPERATURE THERMISTOR	GAS	1	1	1	1	1	TH23				
6	R01 E00 202	PIPE TEMPERATURE THERMISTOR	LIQUID	1	1	1	1	1	TH22				
7	R01 E00 122	MOTOR CAP					1	1					
8	T7W E12 762	FAN MOTOR	(D17D6P70MS)	1	1	1			MF				
	T7W E08 762	FAN MOTOR	(D176P110MS)				1	1	MF				
9	R01 A41 105	MOTOR MOUNT		4	4	4	4	4					

FUNCTIONAL PARTS

PLFY-12NAMU-A
 PLY-20NAMU-A
 PLY-24NAMU-A
 PLY-32NAMU-A
 PLY-40NAMU-A

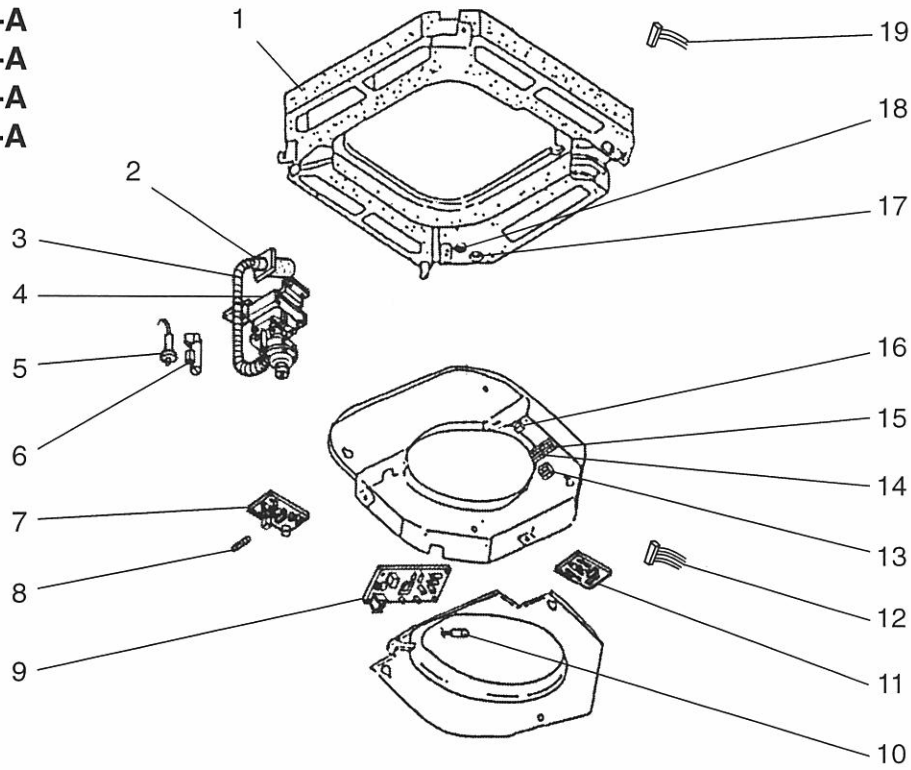

No.	Part No.	Part Name	Specification	Q'ty/set					Remarks (Drawing No.)	Wiring Diagram Symbol	Recom- mended Q'ty	Price	
				PLFY- · NAMU-A								Unit	Amount
				12	20	24	32	40					
1	T7W E09 529	DRAIN PAN		1									
	T7W E06 529	DRAIN PAN			1	1							
	T7W E07 529	DRAIN PAN					1	1					
2	R01 29H 523	DRAIN SOCKET		1	1	1	1	1					
3	T7W E00 527	DRAIN HOSE		1	1	1	1	1					
4	T7W E06 355	DRAIN PUMP		1	1	1	1	1		DP			
5	R01 E00 266	DRAIN SENSOR		1	1	1	1	1		DS			
6	R01 31K 241	SENSOR HOLDER		1	1	1	1	1					
7	R01 E02 313	POWER BOARD		1	1	1	1	1		P.B			
8	T7W 410 239	FUSE	250V 6A	1	1	1	1	1		FUSE			
9	T7W E28 310	CONTROLLER BOARD		1	1	1	1	1		I.B			
10	R01 E58 202	ROOM TEMPERATURE THERMISTOR		1	1	1	1	1		TH21			
11	T7W E00 294	ADDRESS BOARD		1	1	1	1	1		A.B			
12	T7W E00 304	ADDRESS CABLE		1	1	1	1	1					
13	R01 556 716	TERMINAL BLOCK	2P(1,2)	1	1	1	1	1		TB15			
14	T7W E17 716	TERMINAL BLOCK	3P(M1,M2,S)	1	1	1	1	1		TB5			
15	T7W E11 716	TERMINAL BLOCK	3P(L1,L2,GR)	1	1	1	1	1		TB2			
16	T7W E10 255	CAPACITOR	3.0 μ F 440V	1	1	1				C			
	T7W E02 255	CAPACITOR	7.0 μ F 440V				1	1		C			
17	R01 A41 524	DRAIN PLUG		1	1	1	1	1					
18	R01 A48 524	DRAIN PLUG		1	1	1	1	1					
19	T7W E01 304	LEAD ASSY (F/M)		1	1	1	1	1					

12**OPTIONAL PARTS****12-1. Multi function casement**

Part No.	PAC-SG03TM-E
----------	--------------

12-2. Air outlet shutter plate (20 sets)

Part No.	PAC-SG06SP-E
----------	--------------

12-3. High efficiency filter (PAC-SG03TM-E is required in using this optional part.)

Part No.	PAC-SG01KF
----------	------------

CITY MULTI



HEAD OFFICE: MITSUBISHI DENKI BLDG., 2-2-3, MARUNOUCHI CHIYODA-KU, TOKYO100-8310, JAPAN