

11

PARTS LIST

PANEL PARTS PKFY-08NAMU-A

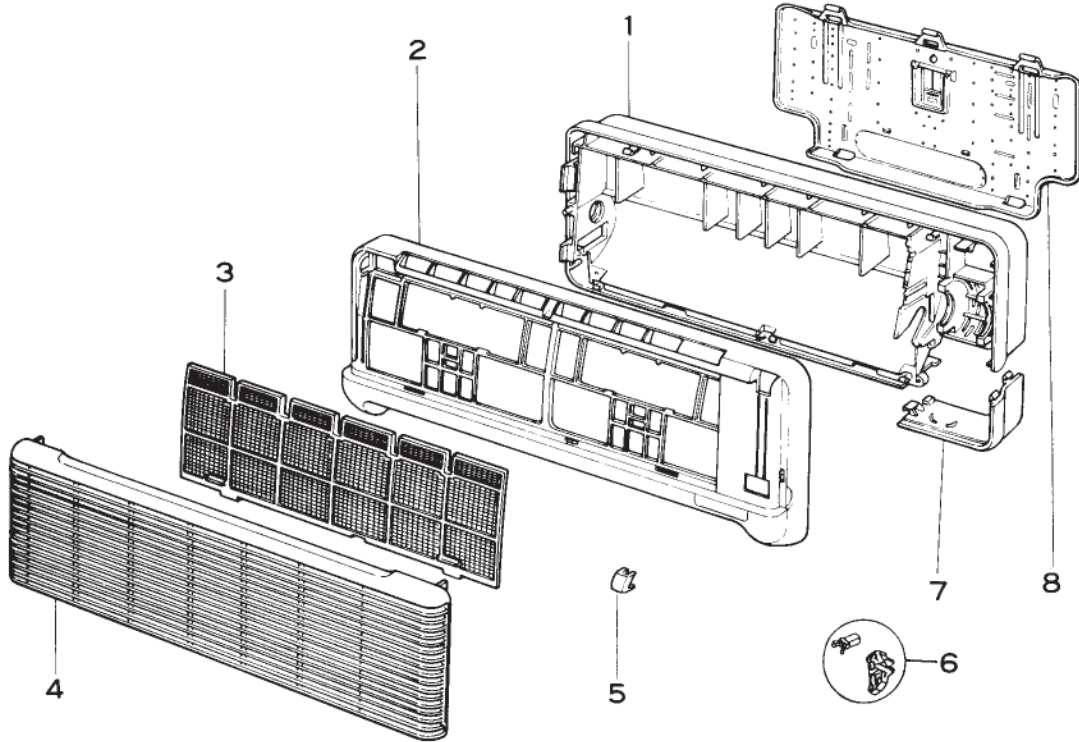

No.	Parts No.	Parts Name	Specifications	Q'ty / set	Remarks (Drawing No.)	Wiring Diagram Symbol	Recom- mended Q'ty	Price	
				PKFY-08NAMU-A				Unit	Amount
1	R01 22A 635	BOX		1					
2	R01 22A 651	FRONT PANEL		1					
3	R01 22A 500	AIR FILTER		1					
4	R01 22A 691	INTAKE GRILLE		1					
5	R01 22A 096	SCREW CAP		1	3PCS/SET				
6	R01 22A 054	GRILLE CATCH		1					
7	T7W A00 658	CORNER BOX		1					
8	R01 22A 808	BACK PLATE		1					

ELECTRICAL PARTS PKFY-08NAMU-A

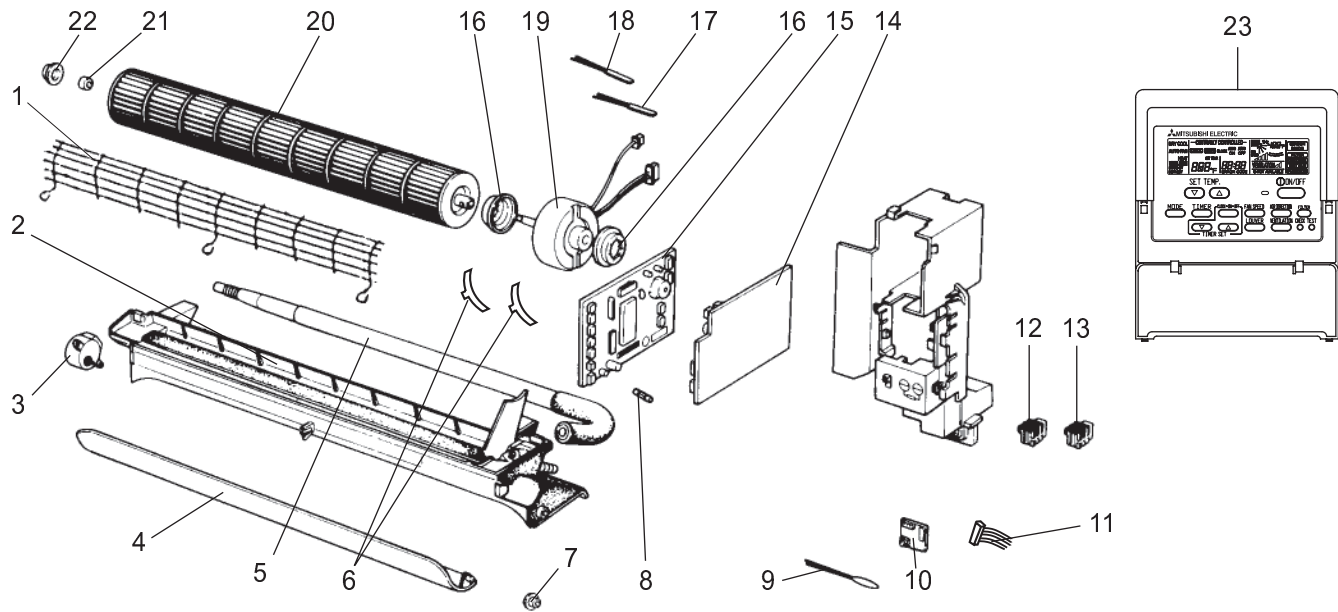

No.	Parts No.	Parts Name	Specifications	Q'ty / set	Remarks (Drawing No.)	Wiring Diagram Symbol	Recom- mended Q'ty	Price	
				PKFY- 08NAMU-A				Unit	Amount
1	T7W B00 675	FAN GUARD		1					
2	R01 22A 530	NOZZLE		1					
3	R01 22A 223	VANE MOTOR		1		MV			
4	R01 22A 002	AUTO VANE		1					
5	R01 22A 527	DRAIN HOSE		1					
6	R01 22A 126	MOTOR BAND	SET (LEFT, RIGHT)	1					
7	R01 07Y 092	VANE SLEEVE		1					
8	T7W 410 239	FUSE	250V 6A	1		FUSE			
9	T7W E12 202	ROOM TEMPERATURE THERMISTOR		1		TH21			
10	T7W E00 294	ADDRESS BOARD		1		A.B			
11	T7W E00 304	ADDRESS CABLE		1					
12	T7W E18 716	TERMINAL BLOCK	3P (L1, L2, GR)	1		TB2			
13	T7W E19 716	TERMINAL BLOCK	2P (M1, M2)	1		TB5			
14	T7W E05 313	POWER BOARD		1		P.B			
15	T7W E29 310	INDOOR CONTROLLER BOARD		1		M.B			
16	R01 22A 105	RUBBER MOUNT		2					
17	R01 E38 202	PIPE TEMPERATURE THERMISTOR	GAS	1		TH23			
18	T7W E06 202	PIPE TEMPERATURE THERMISTOR	LIQUID	1		TH22			
19	T7W E18 762	FAN MOTOR	PS4N8-KA	1		MF			
20	R01 22A 114	LINE FLOW FAN		1					
21	R01 005 103	SLEEVE BEARING		1					
22	R01 22A 102	BEARING MOUNT		1					
23	—	REMOTE CONTROLLER	PAR-20MAU	1		R.B			

↑ This REMOTE CONTROLLER is made by AIR-CONDITIONING & REFRIGERATION SYSTEMS WORKS, MITSUBISHI ELECTRIC CORPORATION.

**HEAT EXCHANGER PARTS
PKFY-08NAMU-A**

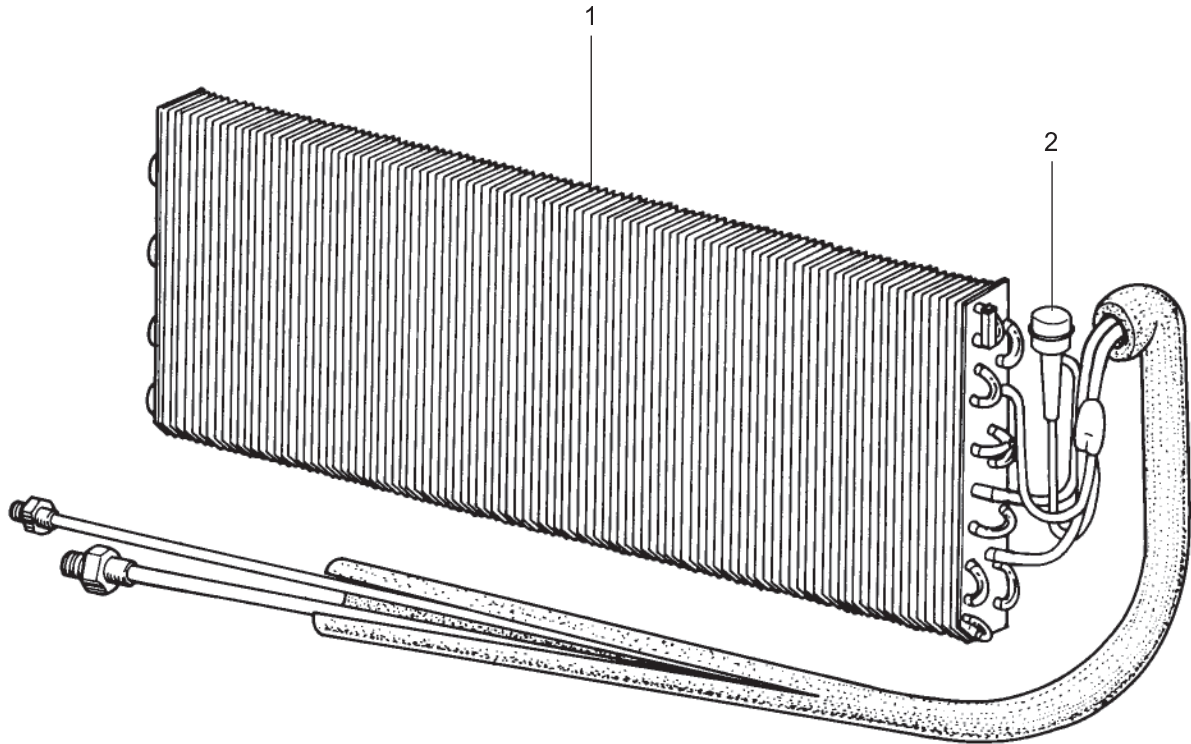

No.	Parts No.	Parts Name	Specifications	Q'ty / set	Remarks (Drawing No.)	Wiring Diagram Symbol	Recom- mended Q'ty	Price	
				PKFY- 08NAMU-A				Unit	Amount
1	T7W E84 480	HEAT EXCHANGER	With connection pipe	1					
2	R01 E27 401	LINEAR EXPANSION VALVE		1		LEV			