

MANUFACTURED BY:
MITSUBISHI ELECTRIC US, INC.

Air Conditioners

PAA-A18, 24, 30, 36, 42AA1/BA1/CA1

INSTALLATION MANUAL

FOR INSTALLER

For safe and correct use, please read this installation manual thoroughly before installing this product.



Table of Contents

| | |
|--|----|
| 1. Warning | 4 |
| 2. System introduction and dimensions | 4 |
| 2.1. Basic operation of the PAA unit | 4 |
| 2.2. System introduction | 4 |
| 2.3. Dimensions | 6 |
| 3. Inspect shipment | 8 |
| 4. Disclaimer | 8 |
| 5. Safety precautions | 8 |
| 5.1. Before installation and electric work | 9 |
| 5.2. Devices that use R410A refrigerant | 12 |
| 5.3. Before getting started | 14 |
| 5.4. Before getting PAA unit installed (moved) - electrical work | 18 |
| 5.5. Before starting the test run | 19 |
| 5.6. After installation and test run | 20 |
| 5.7. To dispose the PAA unit | 20 |
| 6. Indoor unit accessories | 21 |
| 7. Selecting an installation site | 22 |
| 8. Installation | 22 |
| 8.1. Installation clearance | 22 |
| 9. Duct connections | 23 |
| 10. Mount positions | 23 |
| 10.1. TH1 thermistor and NAT thermostat installation | 24 |
| 10.2. Upflow/Downflow installation | 25 |
| 10.3. Horizontal left installation | 35 |
| 10.4. Horizontal right installation | 41 |
| 11. Refrigerant piping work | 41 |
| 11.1. Insulation of refrigerant lines | 43 |
| 11.2. Piping size | 44 |
| 12. Drain connections | 44 |
| 13. Float switch | 46 |
| 14. Installing the control box | 48 |
| 14.1. Control box - cabinet installation | 49 |
| 14.2. Control box - external installation | 50 |
| 15. Electrical wiring | 51 |
| 15.1. Warning and caution | 51 |
| 15.2. Connecting line voltage | 51 |
| 15.3. Function settings | 52 |
| 15.4. PAA unit control box | 54 |
| 15.5. Control signals to the furnace | 57 |
| 15.6. PAA unit control options | 58 |
| 15.6.1. MA remote controller | 58 |
| 15.6.2. Controller options | 59 |
| 15.7. DIP switch for emergency thermostat | 60 |
| 15.8. Balance points | 64 |
| 15.8.1. Economic balance point | 64 |
| 15.8.2. Capacity balance point | 65 |
| 15.8.3. Extended balance point | 65 |
| 15.9. Condensate overflow safety switch connection (CN4F) | 65 |
| 15.10. Energy recovery ventilation (ERV) | 66 |

| | |
|---|----|
| 15.10.1. HRV/ERV heating operation for MXZ/NTXM systems | 67 |
| 15.11. Humidifier | 68 |
| 16. Test run | 69 |
| 16.1. Before test run | 69 |
| 16.2. Perform test run | 70 |
| 16.3. Complete self check | 70 |
| 16.4. Auto restart function | 71 |
| 17. Cut out gauge | 72 |

1. Warning

- This product should only be installed, repaired, serviced, moved, etc. by personnel with the proper training, qualifications and certifications as required by laws and codes.
- Installation, repair, servicing, moving, etc. by persons without proper training, qualifications and certifications as required by laws and codes, or failure to fully read and follow all safety precautions and instructions in this manual may result in serious bodily injury or death.
- Ensure that you read this manual carefully and follow all warnings, cautions and instructions; failure to do so will result in electric shock, property damage, equipment damage, suffocation, fire, smoke, explosions and poisoning.

2. System introduction and dimensions

2.1. Basic operation of the PAA unit

The PAA unit system combines an A-Coil that is mounted on to a furnace with a PAA control box to control the system. The system uses the fan of the attached furnace to operate in Cool mode and while running heat pump in Heat mode. If the system is unable to keep up with the demand for heat, the system switches to furnace operation.

2.2. System introduction



NOTE

- For proper airflow and system performance, only install coils that match within 1" of the furnace width.
- The PAA unit does not support supplemental electric heating systems.

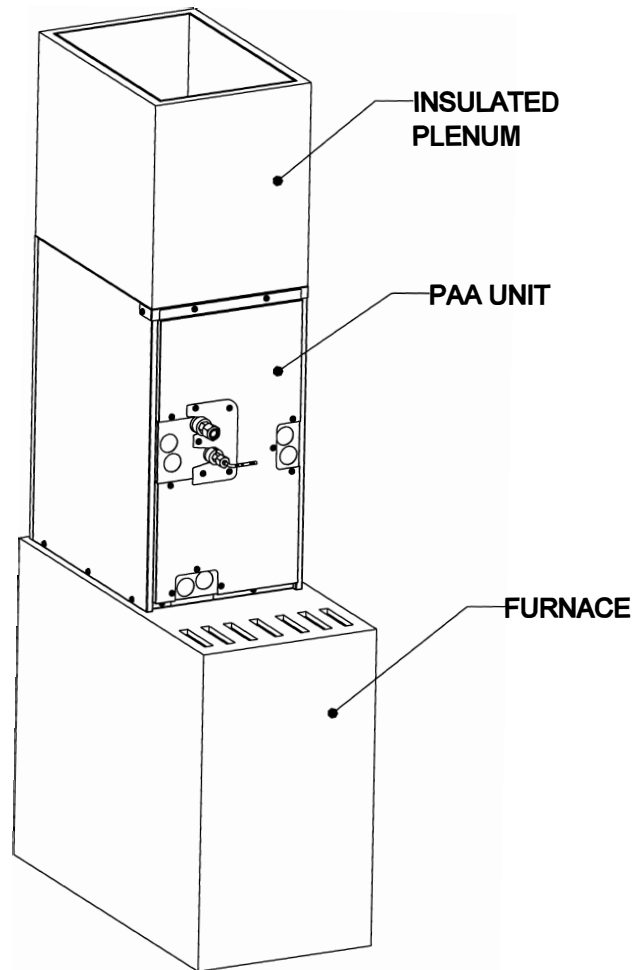

Vertical installations

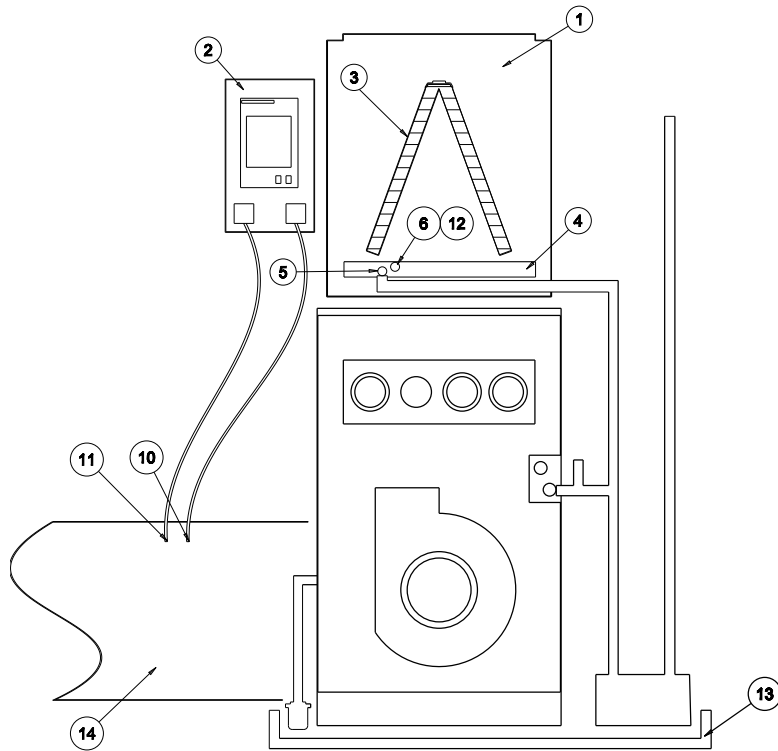

Horizontal installations

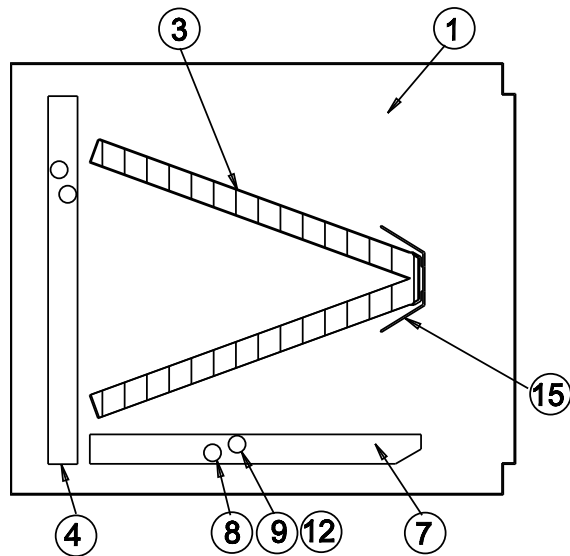

1. PAA unit cabinet
2. Control box
3. Heat exchanger (hex)
4. Main drain pan
5. Main drain pan primary drain
6. Main drain pan secondary drain
7. Side drain pan (for horizontal installation)
8. Side drain pan primary drain (for horizontal installation)
9. Side drain pan secondary drain (for horizontal installation)
10. TH1 thermistor
11. ACH065 (Non-Adjustable Thermostat, NAT)
12. Float switch (installed at secondary drain)
13. Auxiliary drain pan (not included with PAA unit)
14. Inlet duct (not included with PAA unit)
15. Top drain (for horizontal installation)



NOTE

Items 13 and 14 are for reference only and are not provided by Mitsubishi Electric US, Inc.

2.3. Dimensions

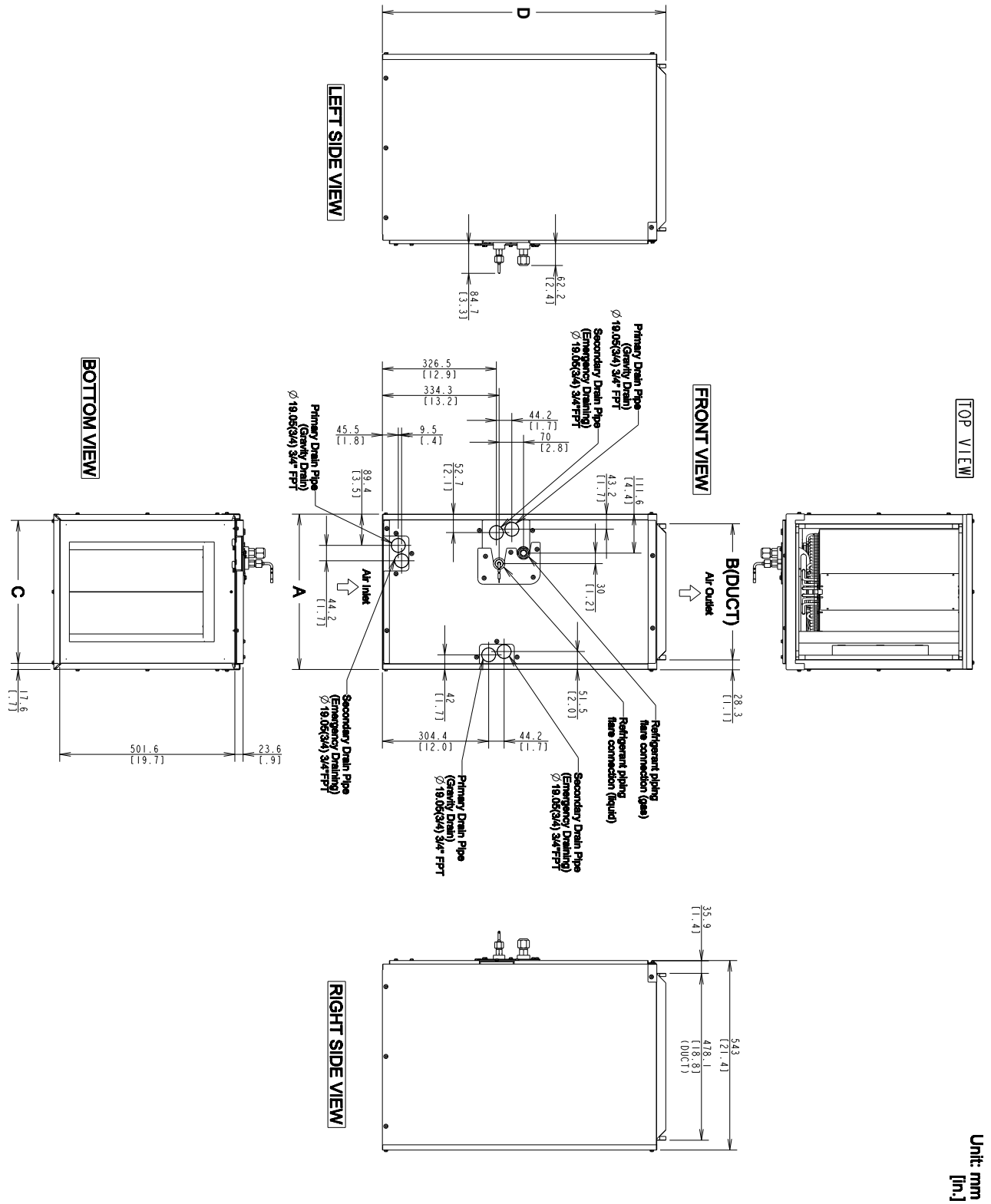

Unit: mm
[In.]

| Model | A mm (inches) | B mm (inches) | C mm (inches) | D mm (inches) |
|------------|---------------------|---------------------|---------------------|---------------------|
| PAA-A18AA1 | 368.3 (14-1/2) | 313.1 (12-5/16) | 332.7 (13-1/16) | 697 (27-7/16) |
| PAA-A18BA1 | 445.0 (17-1/2) | 390.0 (15-5/16) | 409.6 (16-1/8) | 697 (27-7/16) |
| PAA-A24AA1 | 368.3 (14-1/2) | 313.1 (12-5/16) | 332.7 (13-1/16) | 697 (27-7/16) |
| PAA-A30AA1 | 368.3 (14-1/2) | 313.1 (12-5/16) | 332.7 (13-1/16) | 697 (27-7/16) |
| PAA-A24BA1 | 445.0 (17-1/2) | 390 (15-5/16) | 409.6 (16-1/8) | 697 (27-7/16) |
| PAA-A30BA1 | 445.0 (17-1/2) | 390 (15-5/16) | 409.6 (16-1/8) | 697 (27-7/16) |
| PAA-A36BA1 | 445.0 (17-1/2) | 390 (15-5/16) | 409.6 (16-1/8) | 811.6 (32) |
| PAA-A42BA1 | 445.0 (17-1/2) | 390 (15-5/16) | 409.6 (16-1/8) | 811.6 (32) |
| PAA-A36CA1 | 534.6 (21) | 479.4 (18-7/8) | 499 (19-5/8) | 811.6 (32) |
| PAA-A42CA1 | 534.6 (21) | 479.4 (18-7/8) | 499 (19-5/8) | 811.6 (32) |

Control Box

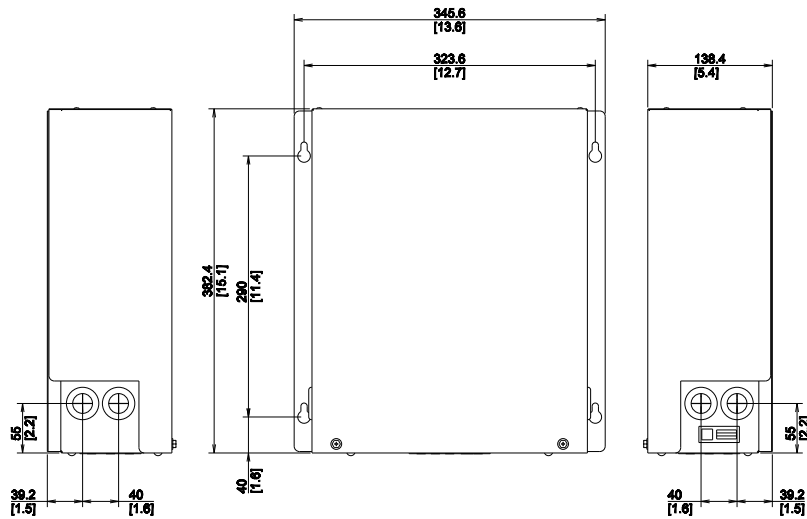

3. Inspect shipment

PAA units are completely factory assembled, and all components are performance tested. Each unit consists of a refrigerant coil in an insulated, galvanized steel factory enclosure, controls in a galvanized steel factory enclosure, and accessories (list of items included in the accessories bag is detailed in "Indoor unit accessories" chapter). Knockouts are provided for drainpipe connections in horizontal orientation installation. Check the unit rating plate to confirm specifications are as ordered. Upon receipt of equipment, carefully inspect it for possible damage. Take special care to examine the unit if the carton is damaged. If damage is found, it should

be noted on the carrier's freight bill. Damage claims should be filed with the carrier immediately. Claims of shortages should be filed with the seller within 5 days.

Do not proceed with installation or operation of the PAA unit if any parts or components are damaged. Doing so may result in significant safety risks, including injury, to the installer. Refer to the "Safety guidelines" warning in the "Before installation and electric work" section of the "Safety precautions" chapter for more information.

4. Disclaimer

Data and information presented in this document are based on tests and information, which we believe to be reliable. This document is provided for information purposes only and does not constitute a warranty, expressed or implied, including any warranty of merchantability or fitness. The instructions, warnings and cautions in this installation manual are not optional and must be followed in order to ensure proper functionality of the product, and to avoid any

injuries or damages to property. It is the installer's responsibility to ensure that the use and installation of this product complies with all applicable national and local building codes.

Manufacturer will not be liable for any damages, structural or otherwise due to the failure to follow the installation requirements listed in this manual.

5. Safety precautions

- Before installing the unit, make sure you read all the safety precautions.
- Ensure all precautions are followed.
- Carefully read the labels affixed to the main unit.

Symbols used in the text



WARNING

Describes precautions that should be observed to prevent danger of injury or death to the user.



CAUTION

Describes precautions that should be observed to prevent damage to the unit.

5.1. Before installation and electric work



IMPORTANT

The Environmental Protection Agency of the United States (EPA) and Canadian Provincial environmental agencies have issued various regulations regarding the introduction and disposal of refrigerants. Failure to follow these regulations may harm the environment and can lead to the imposition of substantial fines.



NOTE

The installation of the unit is regulated by the mechanical code adopted by the authority having jurisdiction.



WARNING

Risks related to PAA unit installation

- PAA unit must be installed by a dealer, contractor, or technician with certifications required by laws and codes.
 - Improper installation by the installer may result in injury or damage to the unit such as water leakage, electric shock, or fire.
- Install the indoor unit in a place that can withstand its weight.
 - Inadequate strength may cause the unit to fall, resulting in injuries.
- Prepare for typhoons, hurricanes, earthquakes, etc., and install the unit at the specified place.
 - Improper installation may cause the unit to topple and result in injury.
- Prohibit anyone without the proper qualifications from doing repairs. If the PAA unit must be repaired, consult a dealer, contractor or technician with certifications required by laws and codes.
 - If the PAA unit is repaired improperly, water leakage, electric shock, or fire may result.
- Install the PAA unit according to this installation manual.
 - If the unit is installed improperly, water leakage, electric shock, or fire may result.

- Ensure the outdoor unit cover panel is installed correctly. Please refer to the outdoor unit's manual for proper installation.
 - If the terminal cover panel is not installed correctly, dust or water may enter the outdoor unit, which could result in fire or electric shock to the user.
- Ensure that the stop valves of the outdoor unit are opened immediately after connecting the PAA unit to the outdoor unit.
 - The PAA unit or refrigerant pipes may burst because of the high-pressure refrigerant during the furnace's heating operation.
- Ensure that the drain pan of the PAA unit is installed properly and that a float switch is connected.
 - If the condensed water of the PAA heat exchanger deviates from the specified path and causes water to leak on to the heat exchanger of the gas furnace; gas, oil and water could leak from the furnace due to corrosion over time. Furthermore, this can lead to poisoning, fire, explosion, water leakage, bodily harm, and damage to property.
- If the PAA unit (this product) is hung from the ceiling in a garage or an occupied area, ensure proper support.
 - Failure to do so may cause the product to fall due to insufficient strength of the suspension or support, or deterioration over time, etc., causing bodily harm and damage to property. In some cases, it can lead to death.



WARNING

Electrical risks

- When sizing wire and completing electrical connections during installation, please follow local codes and standards.
 - Inadequate connections and fastening may generate heat and cause a fire.
- Have all electric work performed by a properly qualified electrician in the state where the electric work is being performed, according to the "National Electrical Code" and local electrical codes, "Interior Wire Regulations" and the

instructions provided in this installation manual, and always use a dedicated breaker.

- If the power source capacity is inadequate or electric work is performed improperly, electric shock or fire may result.
- Keep the electric parts away from water.
 - It might result in electric shock, fire, or smoke.
- Do not reconstruct or change the settings of the protection devices.
 - If the pressure switch, thermal switch, float switch or other protection devices are shorted and operated forcibly, or parts other than those specified by Mitsubishi Electric are used, fire or explosion may result.
- If the power supply wiring is damaged, it must be replaced by the manufacturer service personnel or licensed person.
- Be sure to ground the outdoor unit in accordance with local code. Do not connect the earth cable to any gas pipe, water pipe, lightning rod, or telephone earth cable.
 - Incomplete grounding may cause a risk of electric shock.



WARNING

Refrigerant leak risks

- If refrigerant gas leaks during the installation, ventilate the room and do not use the furnace until a technician confirms that it is safe to use the furnace.
 - If the refrigerant gas comes into contact with a flame, poisonous gases will be released. If an odor is detected, contact a dealer, contractor or technician regarding the appropriate measures to prevent the safety limit from being exceeded.
- After completing installation work, make sure that refrigerant gas is not leaking.
 - If the refrigerant gas leaks and is exposed to a fan heater, stove, oven, or another heat source, it may generate noxious gases.
- Do not use refrigerant other than R410A.
 - Doing so may cause the unit or pipes to burst, or result in an explosion during use, repair, or at the time of disposal of the unit.
 - Doing so may also be in violation of applicable laws.

– The manufacturer, Mitsubishi Electric Corporation, its affiliates and suppliers, cannot be held responsible for malfunctions or accidents resulting from the wrong type of refrigerant used.

- If the outdoor unit stop valve is left closed after installation / service, or when the outdoor unit stop valve is closed due to operation stop, the volume of the liquid refrigerant in the piping expands due to the heating operation in the gas furnace, causing coil or local extension piping to rupture.



WARNING

Fuel leak risks

- Fuel and combustion gas may flow into the room if the exhaust duct is leaking, there is a gap due to insufficient fixing of the connection part, or if regular maintenance is neglected. As a result, fatal hazards such as poisoning and fire explosion may occur, so regular maintenance is recommended to check for the following:
 - Cracked ducts
 - Clogged ducts
 - Insufficient exhaust capacity or abnormal stop of the exhaust fan of gas furnace
 - Gas leak due to gas furnace heat exchanger failure (including corrosion due to poor installation environment)
 - Incomplete combustion due to gas furnace equipment failure (malfunction / parts * failure)
 - * Parts refer to piping, valves, electrical wiring, electrical / electronic parts, sensors, circuit breakers, etc.
 - Short-circuit or ground fault due to ignition, tracking or insufficient insulation of gas furnace parts
 - Damage to internal and external wiring of gas furnace
 - Deterioration of heat resistance, strength, corrosion resistance, insulation, etc. of gas furnace peripheral components
 - Gas furnace protection circuit malfunction
 - Electrical components for electromagnetic noise interference due to normal use over

time, parts failure, and/or installation of nearby electrical devices

- Inadequate confirmation of recalled products from the design / manufacturing year of gas furnace
- Maintaining an abnormal installation state by overlooking a gas furnace installation error or a red tag
- If our equipment is not installed, used, or maintained as described in the PAA unit installation/operation manual, the following problems may occur. In this case, stop the operation immediately by turning off the power, etc., and ask the dealer or contractor for an inspection. Otherwise, gas leaks can cause poisoning, fire, explosions, water leaks, etc., which can cause serious bodily harm and damage to property.
 - If the installation or operating environment is out of the warranty range, the control box may malfunction, and the gas furnace protection functions may also fail and disable. The effect of the excessive heat generated by the gas furnace can cause cracks in the coil section resulting in refrigerant and oil leaks. Furthermore, poisoning, fire, and explosions may occur from this, doing so can cause bodily harm and damage to property.



WARNING

Safety guidelines

- Follow all safety codes specified in the region where the installation is to take place. Wear appropriate protective equipment such as safety glasses, protective clothing and gloves during installation work such as refrigerant filling, torque wrench use, and unit transportation.
 - Failure to follow safety requirements can result in injury or death or building damage.
- Do not touch the heat exchanger fins.
 - Improper handling may result in injury.
- Never substitute parts or components from other manufacturers when repairing or replacing components in the PAA unit. Never install or operate the PAA unit if any parts or components are damaged.



WARNING

Install guidelines

- Read this manual carefully and follow all warnings and cautions provided with this unit. Refer to your local building code and the latest National Electrical Code (NEC) NFPA 70. In Canada, be sure to refer to the latest Canadian Electrical Code CSA C22.1. Also, follow all codes specified by your region. We recommend installing a CO sensor and ventilation system.
 - Failure to follow safety requirements can result in injury, death or building damage.
- When moving and reinstalling the PAA unit, consult the dealer, contractor or technician with certifications required by laws and codes.
 - If the air conditioner is installed improperly, water leakage, electric shock, or fire may result.
- Ask a dealer, contractor or technician with certifications as required by laws and codes to install the accessories.
 - Improper installation by the user may result in water leakage, electric shock, or fire.
- Pay attention to the unit installation location. Refrigerant is heavier than air and locations such as basements or crawl spaces where refrigerant can accumulate can become dangerous.
 - Inadequate ventilation can lead to poisoning.
- The appliance is not intended for use by persons with reduced physical, sensory or mental capabilities, or lack of experience and knowledge (including children) unless they have been given supervision or instruction concerning the use of the appliance by a person responsible for their safety.
- **Do not add UV Lights into the PAA unit cabinet or to the attached ductwork.**
 - **UV Lights can cause degradation to plastic and insulation parts. Water leakage, electric shock, or fire may result.**
- If the gas furnace is not certified to safety standards (ANSI Z21.47/CSA2.3) by a nationally recognized third-party certification organization (AGA, UL, CSA, ETL/Intertek, etc.), or if the gas furnace does not comply with ACCA (Air Conditioning Contractors Association)

Standards and Guidelines (Code), NFPA54 (National Fuel Gas Code), NFPA70 (NEC: National Electrical Code), and if the equipment is not properly installed, used, and maintained in accordance with the building code for each district (state, county, city, town, etc.), the following hazards may occur even if our equipment is properly designed, installed, and operated.

- If a leak sensor is not installed in the room, there is a risk of poisoning symptoms and death without noticing a toxic gas leak.
- Gas fuel has an odor, but if you do not notice it, there is a risk that it can cause poisoning symptoms or an accident, such as a fire or explosion.
- If the safety of gas furnace, gas supply piping, and exhaust duct worsen due to improper ventilation of the system [ventilation must be in accordance with Law, Standard or Guideline (Code)], or due to aging deterioration or the influence of the usage environment, there is a risk of poisoning symptoms due to combustion gas or igniting fuel gas and causing a fire or explosion.



CAUTION

Risks related to PAA unit installation

- When installing and relocating the PAA unit, do not charge it with a refrigerant different from the refrigerant specified on the unit.
 - If a different refrigerant or air is mixed with the original refrigerant, the refrigerant cycle

may malfunction and the unit may be damaged. Use only recommended refrigerant specified in outdoor unit (ODU) manual for system operation (ONLY R410A).

- The PAA unit is designed for indoor installation only.
- The PAA unit must be installed downstream (discharge air) side of the furnace.
- Do not alter the cabinet or braze inside the cabinet.
 - It may affect the performance of the PAA unit.
- Do not use leak detection additive.
 - ODU and PAA unit parts may be damaged by the refrigerant/additive mixture.

Refrigerant leak risks

- The installer (technician) shall ensure there is no refrigerant leakage according to local regulations and standards.
 - Refrigerant leakage will negatively affect the performance of the heat pump.

Install guidelines

- For PAA unit piping connections, use flare connection as the equipment was designed for. Mitsubishi Electric US, Inc. is not responsible for improper brazing connection done by the installer.
 - Improper brazing connections may cause damage to the PAA unit.

5.2. Devices that use R410A refrigerant



CAUTION

Install guidelines

- Do not use the existing refrigerant piping.
 - The old refrigerant and refrigerant oil in the existing piping may contain a large amount of contaminants which may cause the refrigerant oil of the new unit to deteriorate.
- Use refrigerant piping made of C12200 (Cu-DHP) phosphorus deoxidized copper as specified in the ASTM B280 Standard Specification for Seamless Copper Tube for Air Conditioning

and Refrigeration Field Service. Ensure that the inner and outer surfaces of the pipes are clean and free of hazardous Sulphur, oxides, dust/dirt, shaving particles, oils, moisture or any other contaminants.

- Contaminants on the inside of the refrigerant piping may cause the refrigerant residual oil to deteriorate.
- Store the piping to be used during installation indoors and keep both ends of the piping sealed until just before installing it. (Store elbows and other joints in a plastic bag.)

- If dust, dirt, or water enters the refrigerant cycle, deterioration of the oil will result in malfunction of the compressor.
- Do not use a refrigerant other than R410A.
 - If any other refrigerant is used, the contaminants in that refrigerant may cause the refrigerant oil to deteriorate.
 - Since R410A does not contain any chlorine, gas leak detectors for conventional refrigerant will not react to it.
- Use a vacuum pump with a reverse flow check valve.
 - The vacuum pump oil may flow back into the refrigerant cycle and cause the refrigerant oil to deteriorate.
- Do not use the following tools that are used with refrigerants other than R410A:
 - Gauge manifold, charge hose, gas leak detector, reverse flow check valve, refrigerant charge base, vacuum gauge, refrigerant recovery equipment.
- Do not use a charging cylinder.
 - It may cause the refrigerant to deteriorate.
- Always charge refrigerant in a liquid state.
 - Charging refrigerant in the gaseous state will change the composition of the refrigerant and lead to a performance drop.

5.3. Before getting started

PAA unit is compatible with P-Series and M-Series/Nv-Series systems and is available in the following model combinations.

PAA unit and ODU compatibility table

| P-Series | | | | | | |
|---------------------|--------------------------|--------------------------|--------------------------|--------------------------|--------------------------|-----------------------|
| ODU | IDU | | | | | Comment |
| | PAA-A18AA1 PAA-A18BA1 | PAA-A24AA1 PAA-A24BA1 | PAA-A30AA1 PAA-A30BA1 | PAA-A36BA1 PAA-A36CA1 | PAA-A42BA1 PAA-A42CA1 | |
| PUY-A18NKA7 | | | | | | No connection allowed |
| TRUYA0181KA70(N/B)A | | | | | | |
| PUY-A24NHA7 | ✓ | ✓ | | | | |
| TRUYA0241HA70(N/B)A | | | | | | |
| PUY-A30NHA7 | | | ✓ | | | |
| TRUYA0301HA70(N/B)A | | | | | | |
| PUY-A36NKA7 | | | | ✓ | | |
| TRUYA0361KA70(N/B)A | | | | | | |
| PUY-A42NKA7 | | | | | ✓ | |
| TRUYA0421KA70(N/B)A | | | | | | |
| PUZ-A18NKA7 | | | | | | No connection allowed |
| TRUZA0181KA70(N/B)A | | | | | | |
| PUZ-A24NHA7 | ✓ | ✓ | | | | |
| TRUZA0241HA70(N/B)A | | | | | | |
| PUZ-A30NHA7 | | | ✓ | | | |
| TRUZA0301HA70(N/B)A | | | | | | |
| PUZ-A36NKA7 | | | | ✓ | | |
| TRUZA0361KA70(N/B)A | | | | | | |
| PUZ-A42NKA7 | | | | | ✓ | |
| TRUZA0421KA70(N/B)A | | | | | | |
| PUZ-HA24NHA1 | | ✓ | | | | |
| TRUZH0241HA10NA | | | | | | |
| PUZ-HA30NKA | | | ✓ | | | |
| TRUZH0301KA00NA | | | | | | |
| PUZ-HA36NKA | | | | ✓ | | |
| TRUZH0361KA00NA | | | | | | |
| PUZ-HA42NKA1 | | | | | | No connection allowed |
| TRUZH0421KA10NA | | | | | | |

| M-Series/Nv-Series | | | | | | |
|--------------------|------------------------|------------------------|------------------------|------------------------|------------------------|---------|
| ODU | IDU | | | | | Comment |
| | PAA-A18 AA1/ BA1 | PAA-A24 AA1/ BA1 | PAA-A30 AA1/ BA1 | PAA-A36 BA1/ CA1 | PAA-A42 BA1/ CA1 | |
| MXZ-3C24NA3/4 | ✓ | | | | | |
| NTXMMX24A132BA/CA | | | | | | |
| MXZ-3C30NA3/4 | ✓ | ✓ | | | | |
| NTXMMX30A132BA/CA | | | | | | |
| MXZ-4C36NA3/4 | ✓ | ✓ | | | | |
| NTXMMX36A142BA/CA | | | | | | |
| MXZ-5C42NA3/4 | ✓ | ✓ | | | | |
| NTXMMX42A152BA/CA | | | | | | |
| MXZ-SM36NAM/2 | ✓ | ✓ | ✓ | ✓ | | |
| NTXMSM36A142AA/BA | | | | | | |
| MXZ-SM48NAM/2 | ✓ | ✓ | ✓ | ✓ | | |
| NTXMSM48A182AA/BA | | | | | | |
| MXZ-SM60NAM/2 | ✓ | ✓ | ✓ | ✓ | | |
| NTXMSM60A182AA/BA | | | | | | |
| MXZ-3C24NAHZ3/4 | ✓ | | | | | |
| NTXMPH24A132BA/CA | | | | | | |
| MXZ-3C30NAHZ3/4 | ✓ | ✓ | | | | |
| NTXMPH30A132BA/CA | | | | | | |
| MXZ-SM36NAMHZ/2 | ✓ | ✓ | ✓ | ✓ | | |
| NTXMSH36A142AA/BA | | | | | | |
| MXZ-SM42NAMHZ/2 | ✓ | ✓ | ✓ | ✓ | | |
| NTXMSH42A152AA/BA | | | | | | |
| MXZ-SM48NAMHZ/2 | ✓ | ✓ | ✓ | ✓ | | |
| NTXMSH48A182AA/BA | | | | | | |

PAA-series connection

Maximum total piping length

Maximum total piping with PAA connection depends on the number of PAA indoor units connected. Please refer to the table below for the appropriate total maximum piping length the system can be designed to.

Minimum total piping length

For branch box systems where PAA is the only unit(s) connected, the minimum total piping length to each PAA unit from the outdoor unit should be 33 ft.

| Maximum total piping length | | | | | |
|---|--|-------------------------------|-------------------|---|-------------------|
| Model | Total Connected Indoor Capacity (kBtu/h) | Number of PAA units connected | | | |
| | | No PAA unit connected | 1 | 2 | 3 or more |
| MXZ-SM36/48NAM/2 MXZ-SM36/42/48NAMHZ/2 NTXMSM36A14/ 48A182AA/BA NTXMSH36A14/ 42A15/48A182AA/BA | <27 | 492 ft (150 m) | 492 ft (150 m) | Not able to connect 2 or more PAAs for less than 27 kBtu/h | |
| | 28-54 | 492 ft (150 m) | 341 ft (104 m) | 276 ft (84 m) | 276 ft (84 m) |
| | >55 | 492 ft (150 m) | 308 ft (94 m) | 243 ft (74 m) | 243 ft (74 m) |
| MXZ-SM60NAM/2 NTXMSM60A182AA/BA | <27 | 492 ft (150 m) | 492 ft (150 m) | Not able to connect 2 or more PAAs for less than 27 kBtu/h | |
| | 28-54 | 492 ft (150 m) | 408 ft (124 m) | 361 ft (110 m) | 337 ft (103 m) |
| | >55 | 492 ft (150 m) | 384 ft (117 m) | 337 ft (103 m) | 314 ft (96 m) |

The above chart is for M-Series/Nv-Series. For P-Series, follow guidelines in the P-Series outdoor unit installation manual.



NOTE

For extended piping lengths, please refer to Diamond System Builder (DSB).

| PAA unit airflow restriction table | | | | | | |
|------------------------------------|-----|--------------|--------------|--------------|--------------|--------------|
| Airflow | | IDU | | | | |
| | | PAA-A18A/BA1 | PAA-A24A/BA1 | PAA-A30A/BA1 | PAA-A36B/CA1 | PAA-A42B/CA1 |
| Maximum | CMM | 23.0 | 23.5 | 29.0 | 34.0 | 47.0 |
| | CFM | 812 | 830 | 1024 | 1201 | 1660 |
| Minimum | CMM | 12.0 | 15.6 | 19.8 | 22.7 | 26.5 |
| | CFM | 424 | 551 | 700 | 800 | 936 |



NOTE

The above airflow restriction is limited to the heat pump operation only.



IMPORTANT

The furnace fan should be configured such that the airflow is greater than or equal to 350 CFM per ton and less than or equal to 400 CFM per ton of nominal PAA unit cooling capacity.

In downflow orientation, the furnace fan should be configured to maintain an airflow face velocity below 350 ft/min to prevent water blow-off.



WARNING

- Ensure the gas furnace complies with ANSI-Z21.47/CSA2.3 standards by NRTL 3rd party lab such as AGA, CSA, UL, or ETL/Intertek. Mitsubishi Electric air conditioner/heat pump system must only be connected with ANSI-Z21.47/CSA2.3 certificated gas furnace.
 - Improper connection may result in poisonous gas, fire, explosion, electric shock or water leak.
- Do not install the PAA unit onto any OIL or DRUM type furnaces.
 - Failure to follow this warning could result in personal injury or death.
- Do NOT install the PAA unit on any furnaces or applications where supply air temperature could exceed 200° F.
 - Failure to follow this warning could result in personal injury or death.
- The PAA unit should only be installed on a furnace with an output capacity no greater than 300% of the rated PAA unit cooling capacity.
 - Failure to follow this warning could result in personal injury or death.



CAUTION

- Do not use the PAA unit in special environments.
 - Oil, steam, sulfuric smoke, etc. can significantly reduce the performance of the PAA unit or damage its parts.
- Always lock the furnace disconnect switch, if present, in the open position prior to servicing the PAA unit.
- When installing the unit in a hospital, communication station, or similar place, provide sufficient protection against electromagnetic noise.
 - The INVERTER equipment, private power generator, high-frequency medical equipment, or radio communication equipment may cause the PAA unit to operate erroneously, or fail to operate. On the other hand, the PAA unit may affect such equipment by creating electromagnetic noise that disturbs medical treatment of image broadcasting.
- Install the drain piping according to this installation manual to ensure proper drainage. Wrap thermal insulation around the pipes to prevent condensation.

- Improper drain piping may cause water leakage and damage to furniture and other possessions.
- Make sure an auxiliary drain pan is installed to prevent occasional condensation from damaging the building.
- When the room humidity exceeds 80% or when the drain pipe is clogged, condensation may drip from the indoor unit. Perform collective drainage work together with the outdoor unit, as required.
- When the ambient dew point temperature exceeds 73° F (23° C), dew condensation may occur on the unit surface. Perform appropriate treatment, such as duct wrap insulation, to avoid dew condensation.

**NOTE**

Keep this installation manual with the unit. Carefully read all instructions for the installation prior

to installing product. Make sure each step or procedure is understood and any special considerations are taken into account before starting installation.

Gather all tools, hardware and supplies needed to complete the installation. Refer to the "System introduction" and "Indoor unit accessories" sections for items that are not included with the PAA unit. Make sure everything needed to install the product is on hand before starting.

**WARNING**

- Failure to follow this warning could result in property damage, severe personal injury, or death: verify the furnace is properly installed according to the gas furnace installation manual and local building codes.

5.4. Before getting PAA unit installed (moved) - electrical work

**NOTE**

Ensure the wiring is not pinched or damaged when fitting the control box cover.

**WARNING**

- Be sure to ground the PAA unit and outdoor unit.
 - Do not connect the earth cable to any gas pipe, water pipe, lightning rod, or telephone earth cable. Incomplete grounding may cause a risk of electric shock. If the power supply wiring is damaged, it must be replaced by a dealer, contractor or technician with certifications as required by laws and codes, in order to avoid a hazard.
- Install the power cable so that tension is not applied to the cable.
 - Tension may cause the cable to break and generate heat and cause a fire.
- Install a leak circuit breaker as required.

- If a leak circuit breaker is not installed, electric shock may result. Use power line cables of sufficient current carrying capacity and rating. Cables that are too small may leak, generate heat, and cause a fire.
- Use power line cables of sufficient current carrying capacity and rating.
 - Cables that are too small may leak, generate heat, and cause a fire.
- When sizing wire and completing electrical connections during installation, please follow local codes and standards.
 - Fuse or circuit breaker of a larger capacity or a steel or copper wire may result in a general unit failure or fire.
- Do not wash the PAA unit.
 - Washing the PAA unit may cause an electric shock.
- Ensure that the installation base is not damaged.
 - If damaged, the unit may fall and cause personal injury or property damage.
- Install the drain piping according to this installation manual to ensure proper drainage. Wrap

thermal insulation around the pipes to prevent condensation.

- Improper drain piping may cause water leakage and damage to furniture and other possessions.
- Be very careful about product transportation.
 - If the product weighs more than 20 kg [44 lb], more than one person should carry the product.
 - Some products use polypropylene band (PP) bands for packaging. Do not use any PP bands for a means of transportation; it is dangerous.
 - Do not touch the heat exchanger fins. Doing so may cut your fingers.
- Safely dispose of the packing materials.
 - Packing materials, such as nails and other metal or wooden parts, may cause stabs or other injuries.
 - Tear apart and throw away plastic packaging bags so that children will not play with them.

If children play with a plastic bag which was not torn apart, they face the risk of suffocation.

- Before installing or servicing system, always turn off main power to system. There may be more than one disconnect switch. Tag disconnect switch with a warning label.
 - Failure to follow this warning could result in personal injury or death.
- Always disconnect power to the furnace before removing the blower door.
 - Failure to disconnect power may result in electric shock or injury.
- Label all wires prior to disconnection when servicing controls. Verify proper operation after servicing.
 - Wiring errors can cause improper and dangerous operation.

5.5. Before starting the test run



CAUTION

- Open the stop valves isolating the PAA unit from the outdoor unit before completing the installation to avoid refrigerant pipe bursting during furnace operation.
- Turn on the power at least 12 hours before starting operation.
 - Starting operation immediately after turning on the main power switch can result in severe damage to internal parts. Keep the power switch turned on during the operational season.
- Do not turn off the power immediately after stopping operation. Wait at least five minutes before turning off the power.
 - Turning off the power immediately may cause a water to leak.



WARNING

- Do not touch the switches with wet fingers.
 - Touching a switch with wet fingers can cause electric shock.

- Do not touch the refrigerant pipes during and immediately after operation.
 - During and immediately after operation, the refrigerant pipes may be extremely hot or cold, depending on the condition of the refrigerant flowing through the refrigerant piping, compressor, and other refrigerant cycle parts. Your hands may suffer burns or frostbite if you touch the refrigerant pipes.
- Read the chapters from the "Selecting an installation site" chapter to the "Electrical wiring" chapter carefully before operating the equipment. Do not operate the furnace, PAA unit or outdoor unit with the panel or guard removed.
 - Injury may occur if you touch the rotating fan of the furnace or outdoor unit, high-temperature parts such as compressors and pipes, or high-voltage parts such as terminal blocks.
- Do not store or use gasoline or other flammable vapors and liquids in the vicinity of this or any other appliance.
- What to do if you smell gas?
 - Do not touch any electrical switch.
 - Do not use any phone in your building.

- Immediately call your gas supplier from a neighboring location.
- Follow the gas supplier's instructions.
- If you cannot reach your gas supplier, call the fire department.
- Do not try to light any appliance.
- Never use an open flame to detect refrigerant leaks. Explosive conditions may occur. Use a leak test sensor or other approved methods for leak testing. Should furnace discharge air supply overheating occur and the gas supply fails to shut off, follow the furnace installation manual to disable the gas and electric supply to the furnace.

5.6. After installation and test run

CAUTION

- When cleaning the heat exchanger and drain pan, ensure water does not get spilled over furnace parts, PAA unit insulation or air duct insulation.
 - Water can cause heat exchanger corrosion and contribute to insulation aging.
- Monitor the building temperature during periods of cold weather. If for any reason your HVAC system should fail to operate, damage such as burst water pipes could result from lack of proper heating to the space.

5.7. To dispose the PAA unit

CAUTION

To dispose of the PAA unit, consult a dealer, contractor or technician with certifications required by laws and codes.

6. Indoor unit accessories

The accessories bag contains the following items:

| Part No. | Description | Qty |
|----------|---|-----|
| 1 | Float switch SS2 | 1 |
| 2 | Wire nuts | 5 |
| 3 | Installation manual | 1 |
| 4 | ACH065 Thermostat (NAT) | 1 |
| 5 | CN4F wire assembly | 1 |
| 6 | Screws (M5) | 8 |
| 7 | TH1 Thermistor | 1 |
| 8 | Bracket | 1 |
| 9 | Zip ties | 2 |
| 10 | Operation manual | 1 |
| 11 | Troubleshooting guide | 1 |
| 12 | Washers | 8 |
| 13 | U-bend covers (PAA-A36 and PAA-A42 models only) | 2 |



L-bracket (not in accessories bag), qty = 1

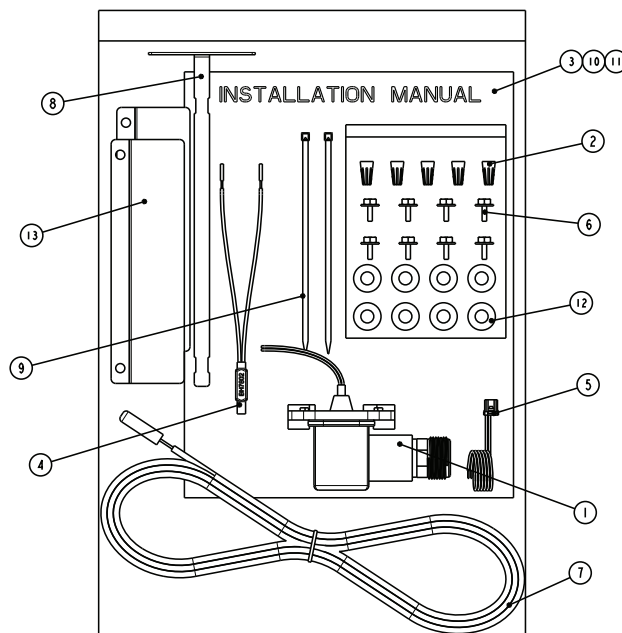

7. Selecting an installation site

- Avoid installing the PAA unit in locations exposed to outside air.
- Avoid installing the PAA unit and control box in locations that will expose it to steam or vapor.
- Avoid installing the control box near locations where combustible gas or oil may leak, settle, or be generated.
- Avoid installation near machines emitting high-frequency waves (high frequency welders, etc.).
- Avoid installing the PAA unit in places where acidic solutions are frequently used.
- Avoid installing the PAA unit in places where sulphur-based or other sprays are commonly used.

8. Installation

PAA unit shipment contains the following items:

1. Cased coil (includes pre-installed, TH2 / TH5 pipe thermistor assembly)
2. Control box
3. Accessories bag
4. L-bracket

PAA units are shipped factory installed with internal vertical and horizontal drain pans, which can be configured for upflow / downflow, horizontal right or horizontal left configurations. Internal horizontal drain pan is not required for vertical configurations.

In upflow / downflow configurations, aluminum foil tape must be applied to seal the top edge of the insulation to the cabinet. This tape will prevent the possibility of the insulation delaminating and blocking airflow. Coil should be level or pitched slightly toward the drain connection.

Because of varying furnace opening depths, a gap may be present between the front of the coil and furnace opening. To fill this gap, install the provided L-bracket as shown below. Then form an air-tight seal with aluminum foil tape, approved tape or mastic.

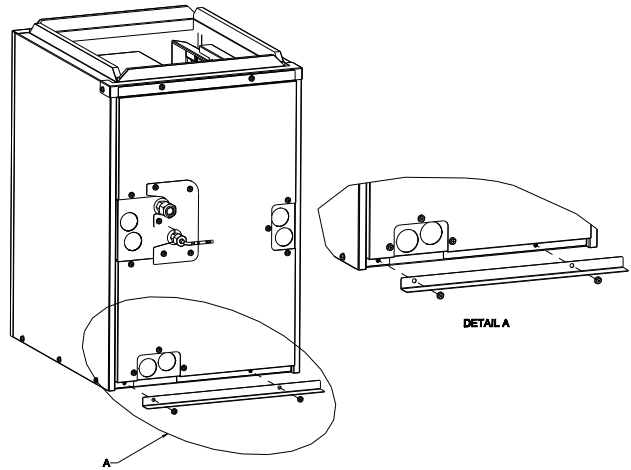

8.1. Installation clearance

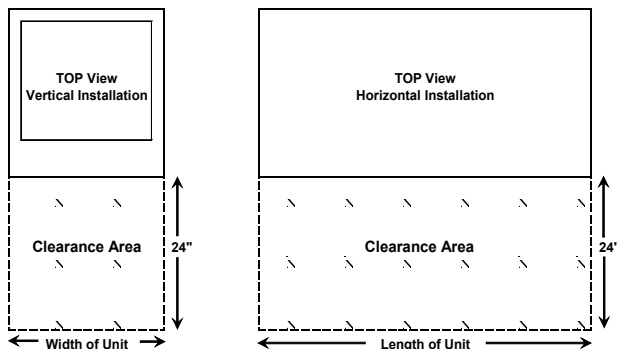

9. Duct connections

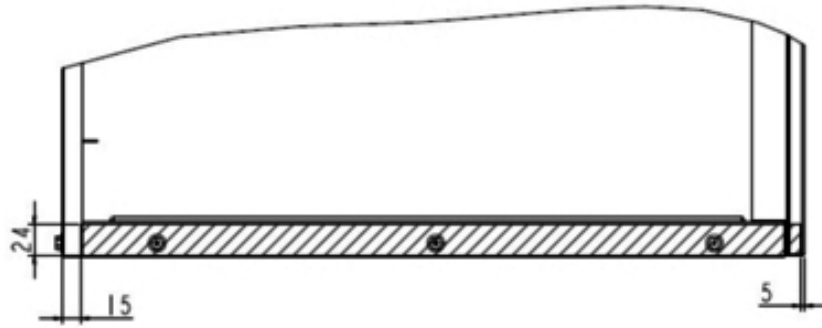

Side View

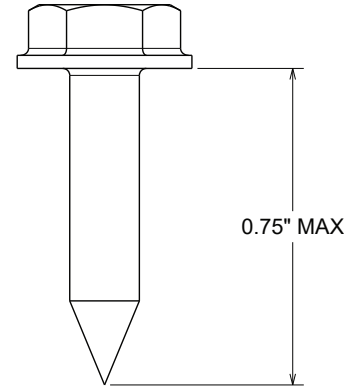

NOTE

- See the outline drawing in the "Dimensions" section for the size of the duct connection.
- Use flanged ducts for connections to return.
- Do not use sheetmetal screws longer than 0.75" to secure any ductwork to the PAA unit cabinet.



CAUTION

- Add additional external insulation to prevent surface condensation.
 - Improper installation may cause damage to the unit or surroundings due to condensation.



NOTE

Installer can use screws only in the shaded area indicated above, when connecting to the furnace or return ductwork.

10. Mount positions

PAA unit can be installed in one of the following configurations: upflow, downflow, horizontal right or horizontal left orientation.



NOTE

All images displayed in this chapter are for the PAA-A18BA1 (17.5").

10.1. TH1 thermistor and NAT thermostat installation

Where applicable, the TH1 thermistor and NAT thermostat must be installed in the return air duct work with the bracket provided in the accessories bag. Extend NAT wires as needed using field-supplied 20-18 gauge stranded wire and using wire nuts provided in accessories bag.

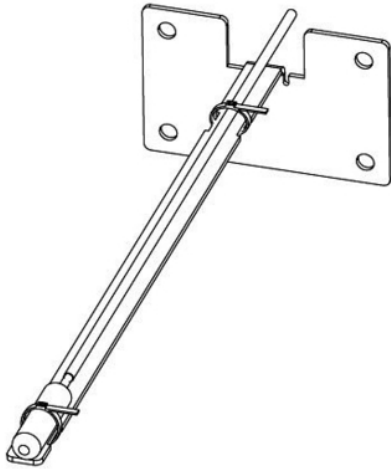

TH1 thermistor installed

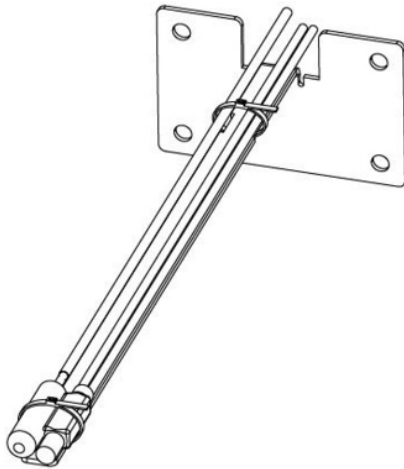

TH1 thermistor and NAT thermostat installed

TH1 thermistor and NAT thermostat installed in the return air duct work displayed below:

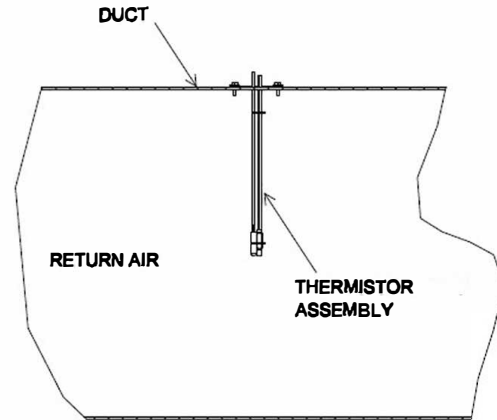

CAUTION

Do not install the TH1 thermistor and NAT thermostat on the discharge side of the gas furnace. This may cause thermistor and/or thermostat failure.

Also, do not install the TH1 thermistor and the NAT near any bypass duct or too close to the furnace. Doing so will cause damage to the TH1 thermistor and the NAT from heat from the furnace.

NOTE

When installing the PAA unit into unconditioned spaces, note that air temperatures in the ductwork (as measured by the return air thermistor) may vary from the space temperature. Where this variance is large, it can affect the system's ability to cool the occupied space down to the minimum cooling set point or heat up to the maximum heating set point.

The following measures can be applied to mitigate the effect of the temperature variance:

- Insulate the ductwork.
- Use a remote sensor or a remote controller with a built-in sensor.
- Place the return air thermistor as far away from the furnace as possible, avoiding bypass ducts,

but taking care to ensure that all return duct branches remain upstream of the thermistor.

- Ensure that the provided mounting bracket is used to position the return air thermistor well within the airstream.
- Set Modes 25 and 27 to 1 for fan on during Thermo OFF.
- Install PAC-USSEN00(1|2)FM-1 as the return air sensor, placed into the conditioned space.
- Use kumo cloud[®] in conjunction with the PAC-USWHS003TH-1 wireless temperature and humidity sensor.

10.2. Upflow/Downflow installation

The cabinet containing the hex assembly is shipped in the horizontal right configuration. Modifications will need to be made for other desired configurations.

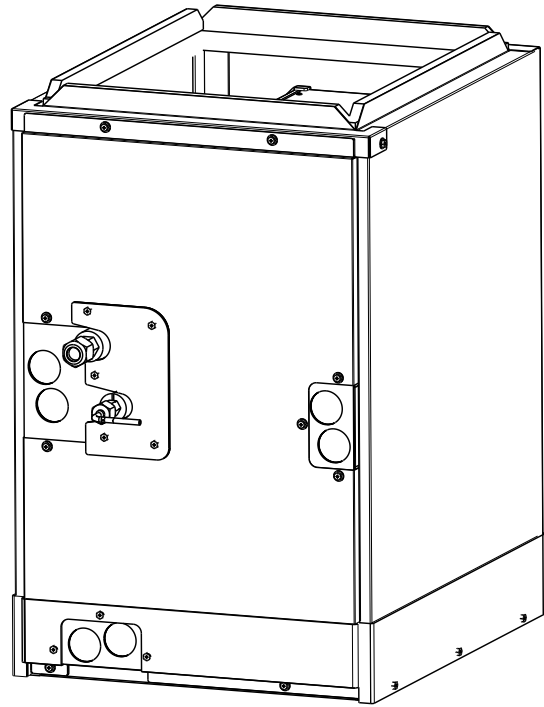

When installing the four large PAA unit models (PAA-A36, 42 BA1/CA1) in the downflow configuration, the two U-bend covers provided in the accessories bag must be installed on the unit. (The two U-bend covers are indicated as Part no. 13 in the accessories bag item list in the Indoor unit accessories section.)

Installing the U-bend covers directs potential dew condensation blow-off into the main drain pan.

ATTENTION!

THE TWO U-BEND COVERS PROVIDED IN THE ACCESSORIES BAG MUST BE INSTALLED ON THE FOLLOWING MODELS WHEN INSTALLED IN DOWNFLOW:

- PAA-A36BA1
- PAA-A36CA1
- PAA-A42BA1
- PAA-A42CA1

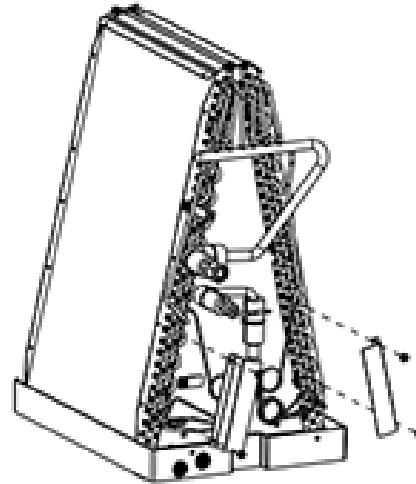

The side drain pan and the top drain must be removed from the coil assembly for vertical configuration installations. Remove the side drain pan (as well as its support and 2 triangular

pieces) and the top drain as shown in the following steps. Removal of the side drain pan and top drain increases airflow and efficiency.

ATTENTION!

FOR UPFLOW AND DOWNFLOW INSTALLATIONS:

1. THE TOP DRAIN MUST BE REMOVED (AS SHOWN).
2. THE SIDE DRAIN PAN MUST BE REMOVED (AS SHOWN).

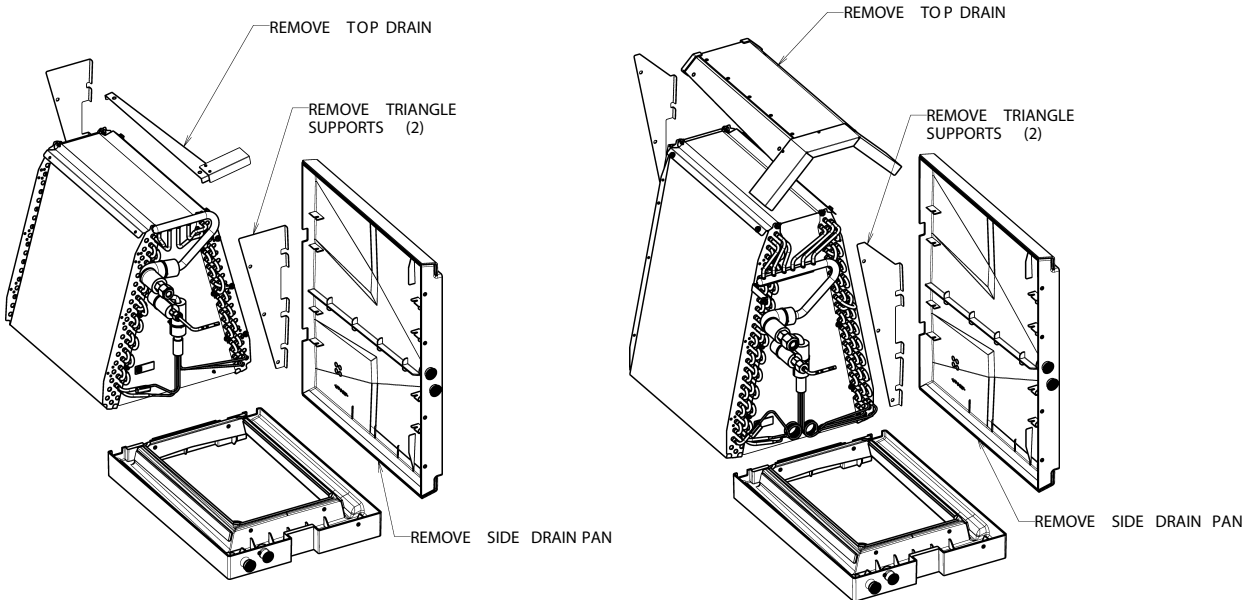

This configuration is for the PAA -A18 models only.

Step 1: Remove pipe panel which is secured by 5 screws, as displayed below:

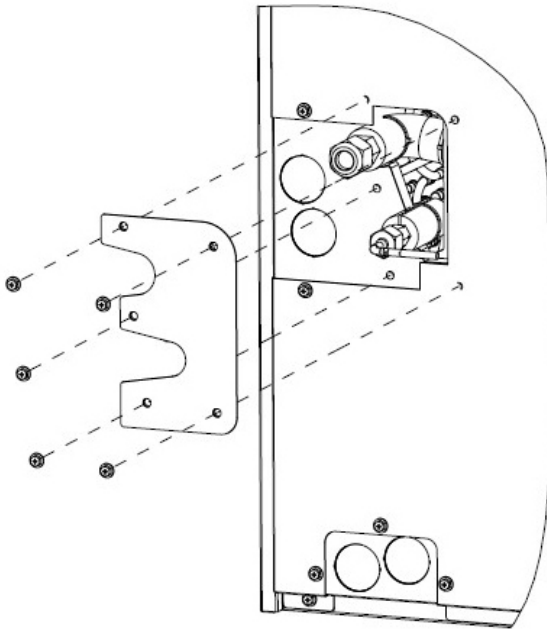

Step 2: Remove front panel which is secured by 12 screws. (Screws not shown.)

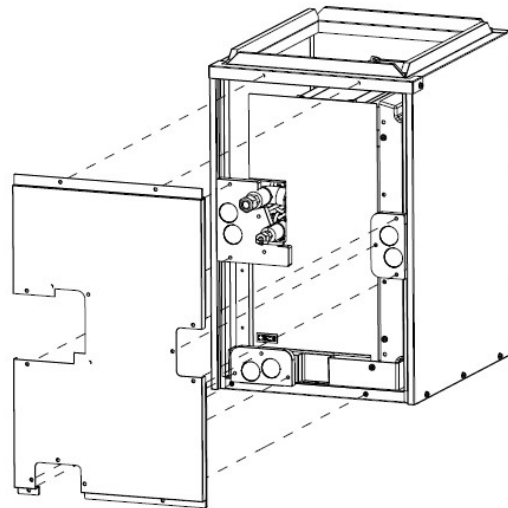

Step 3: Remove pipe panel (main pipe panel) which is hooked to the cabinet, by moving it in the directions indicated in the image below and then removing it from the cabinet.

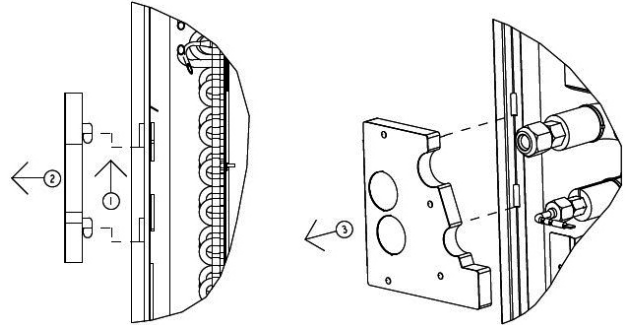

Step 4: Remove the 2 side panels (side pipe panel assembly), which are hooked to the cabinet, by moving them in the directions indicated in the images below and removing them from the cabinet.

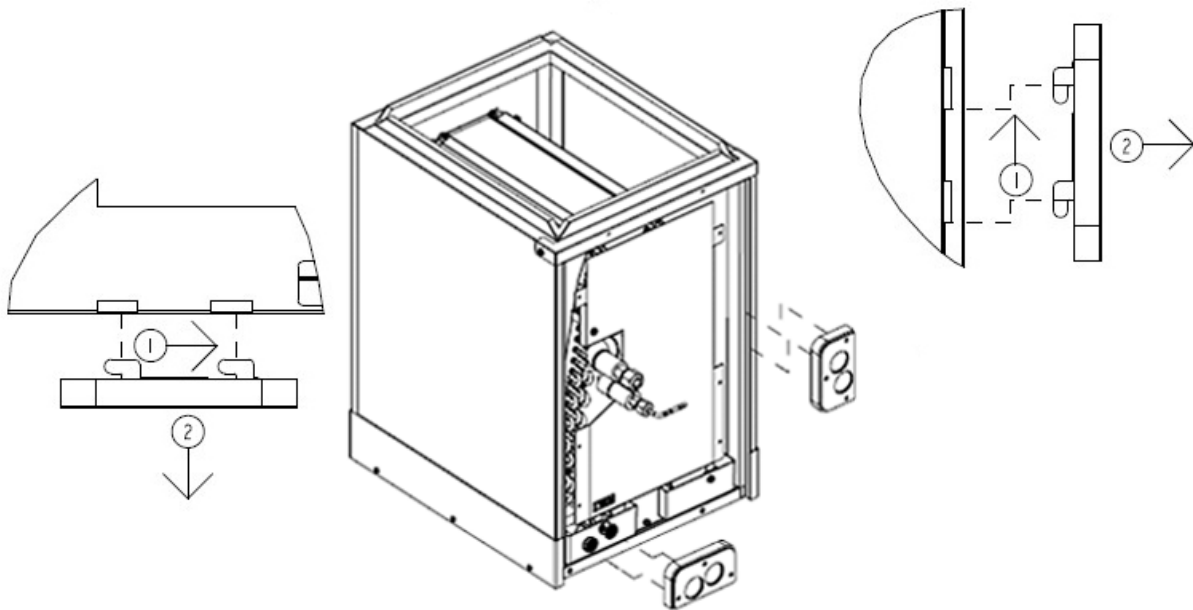

Step 5: Remove front Z-bracket, secured by a screw, which is located on the shelf attached to the drain pan.

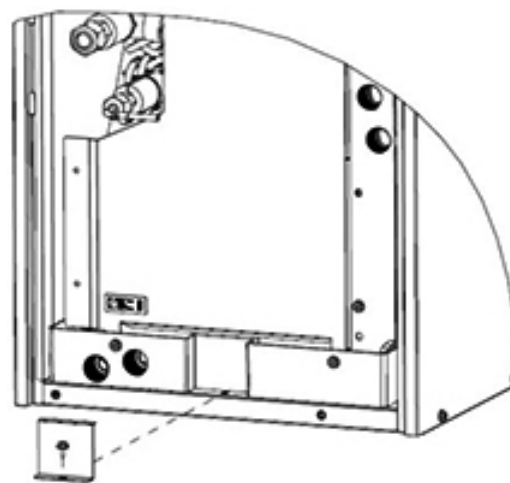

Step 6: Remove the side drain pan support from the side drain pan by sliding the support over and pulling it up. Retain the side drain pan support for horizontal left installation. Discard (recycle) the support for upflow/downflow installations.



NOTE

Side drain pan support must be removed while the heat exchanger is inside the cabinet. Some parts are not shown for clearer image.

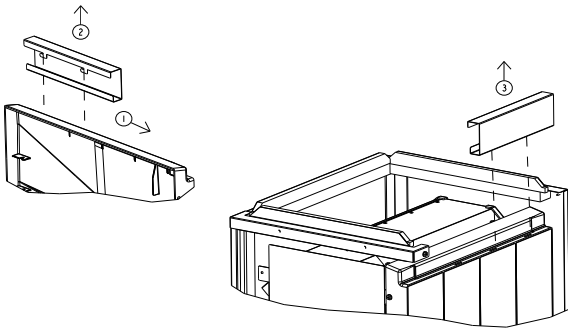

Step 7: Remove the heat exchanger assembly by sliding it out of the cabinet.



CAUTION

- Use extreme caution when removing the heat exchanger from the cabinet as the thermistor wires are attached to the assembly.
 - Damaging these wires may cause the unit to malfunction.

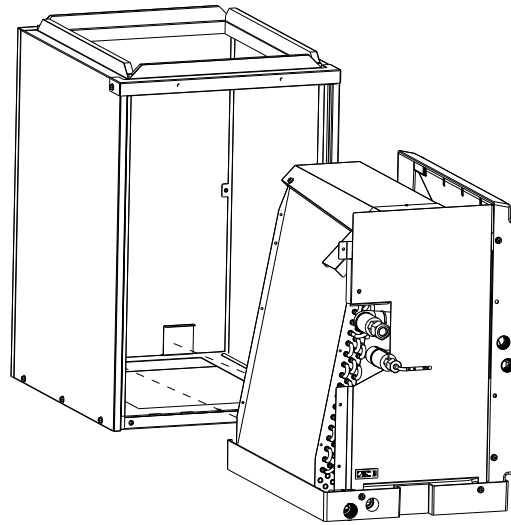

Step 8: Remove front plate (holds the side and main drain pans), which is secured by 5 screws.

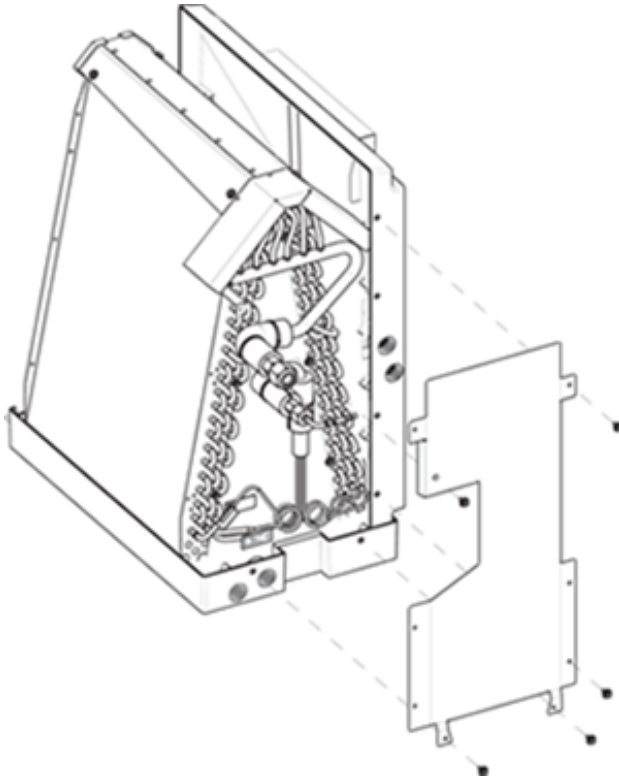

Step 9: Lift the heat exchanger by removing the 4 screws securing it to the drain pan.

! WARNING

- Removing the heat exchanger may cause the side drain pan to fall off the main drain pan.
 - Drain pan may fall and cause personal injury.

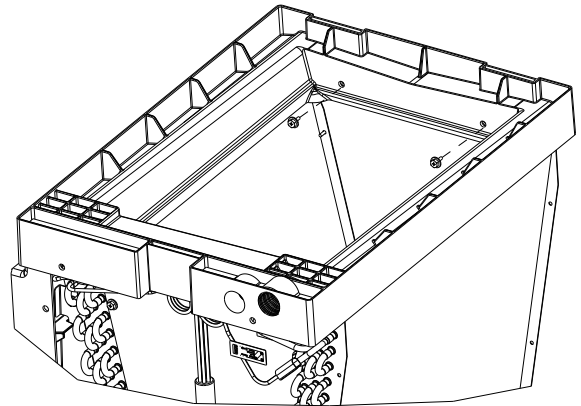

PAA unit inverted to show how the 4 screws are removed.

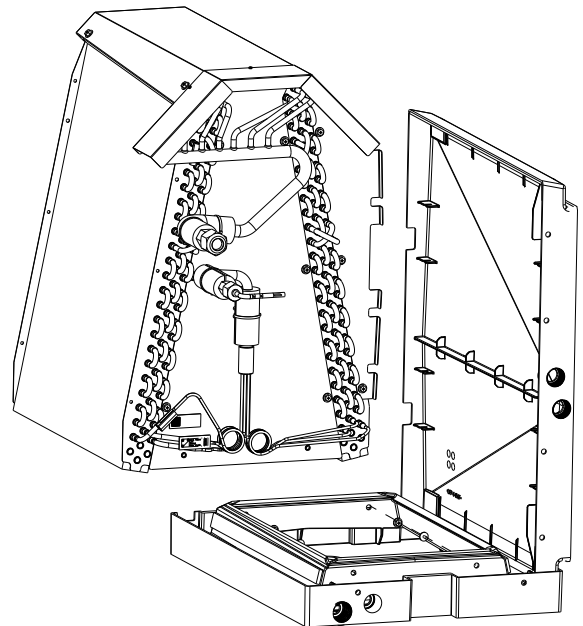

Step 10: Remove the side drain pan.

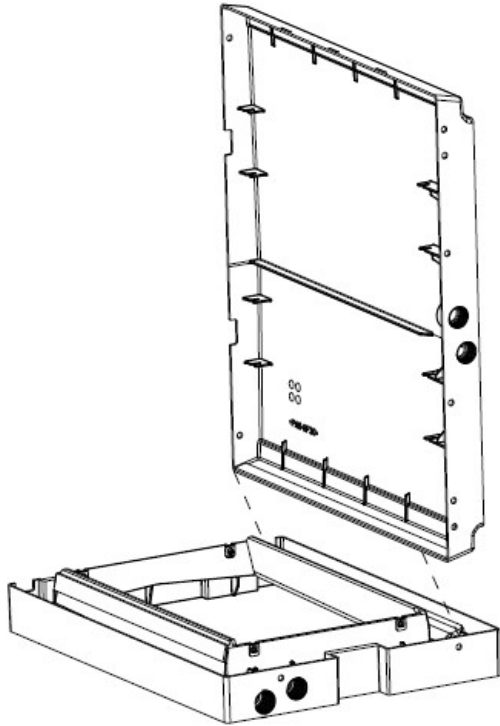

Step 12: Remove the top drain located on top of the heat exchanger, held with 4 screws. Discard (recycle) the top drain.

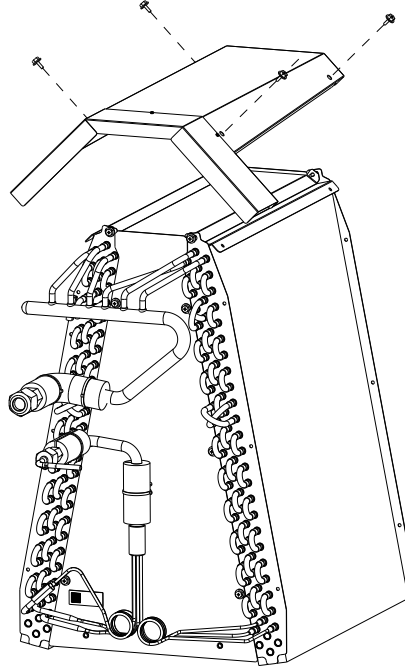

Step 11: Remove the 2 triangular pieces, held with 6 screws, from the heat exchanger assembly. Discard (recycle) the pieces.

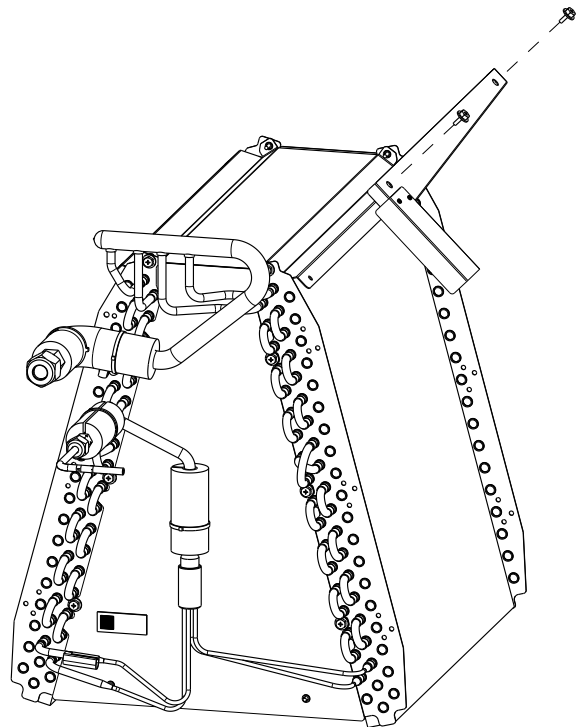
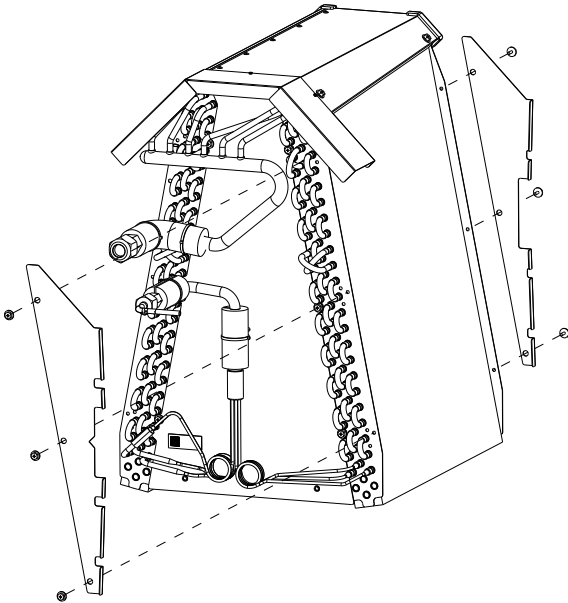

For PAA-A18

Step 13: Attach the heat exchanger to the main drain pan with the 4 screws.

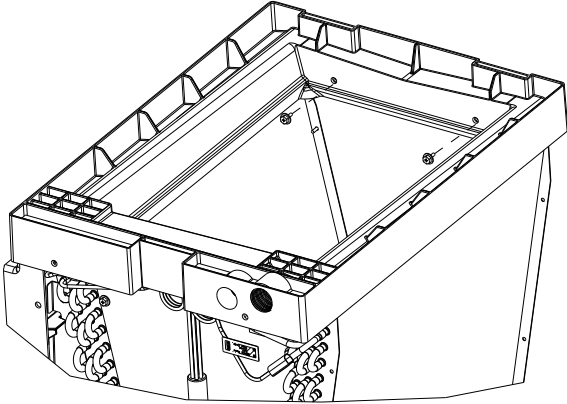

PAA unit inverted to show how the 4 screws are installed.

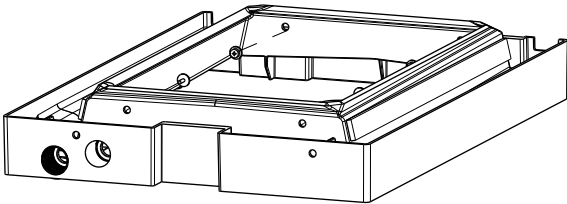
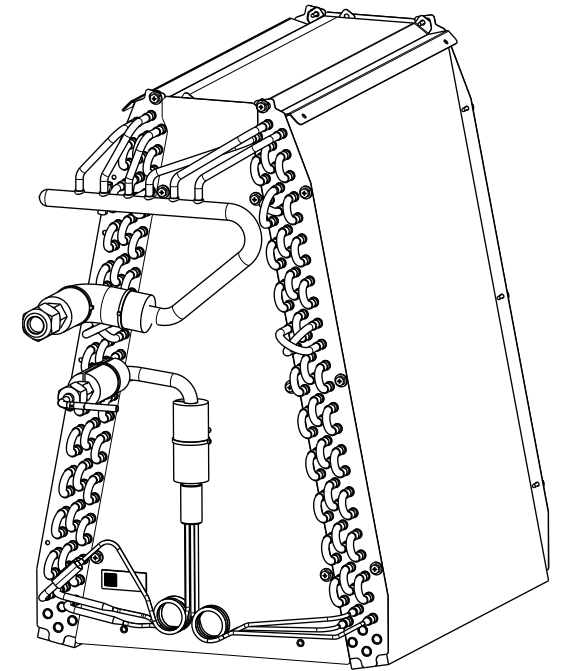

Step 14: When installing PAA unit models PAA-A36,42 BA1/C1 in the downflow configuration, attach the two U-bend covers provided in the accessories bag with the provided 4 screws.

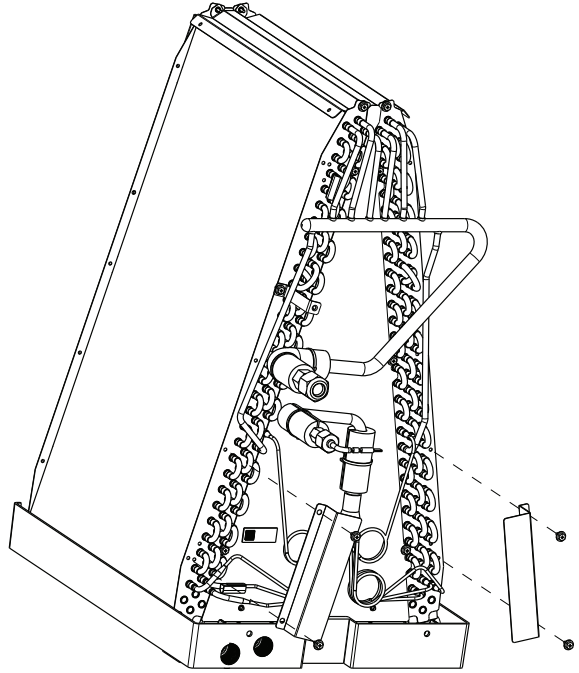

Perform the following steps to replace the heat exchanger (without side drain pan) inside the cabinet.

Step 15: Attach the front plate to the main drain pan using the 3 screws.

Step 16: Insert the heat exchanger back into the cabinet.



CAUTION

- Use extreme caution when inserting the heat exchanger back into the cabinet to avoid damaging the thermistor wires.
 - Damaged thermistor wires may result in improper or dangerous operation of the unit.

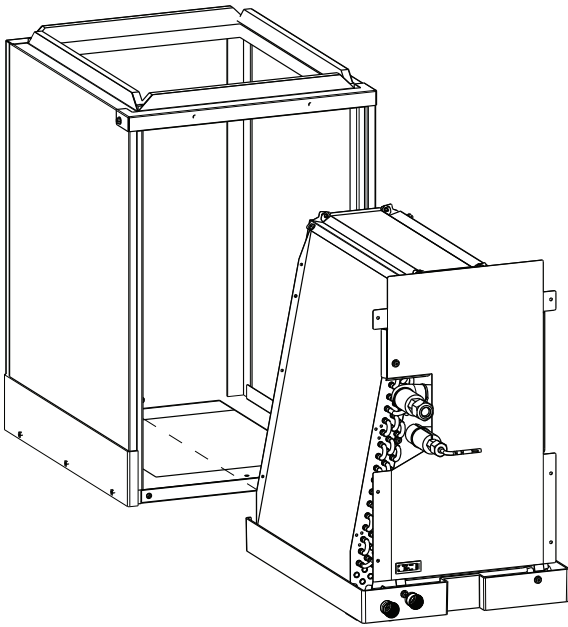

Step 17: Use screw (1) to install the front Z-bracket to secure the heat exchanger to the cabinet.

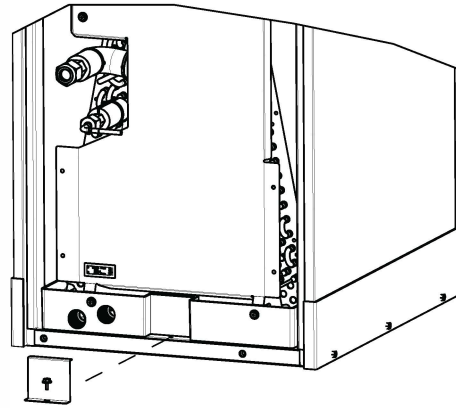

Step 18: Replace the 2 side panels (side pipe panel assemblies).

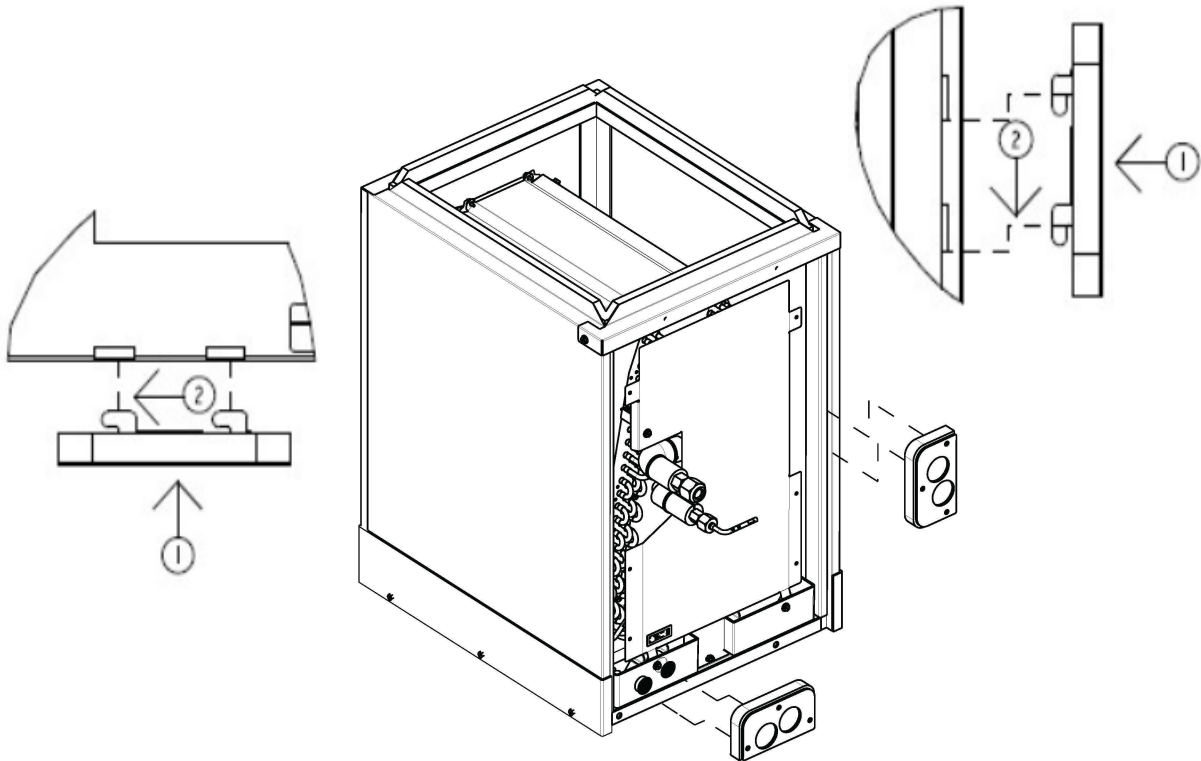

Step 19: Replace the pipe panel (main pipe panel).

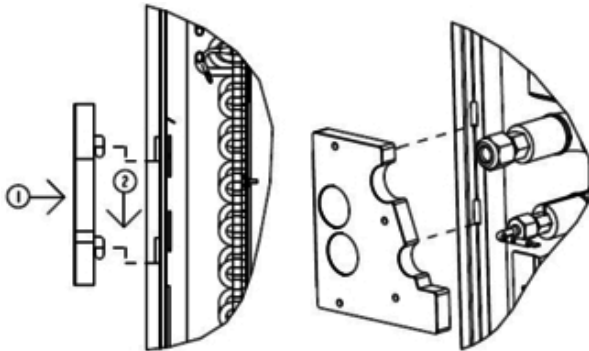

Step 20: Replace the front panel using the 12 screws. (Screws not shown.)

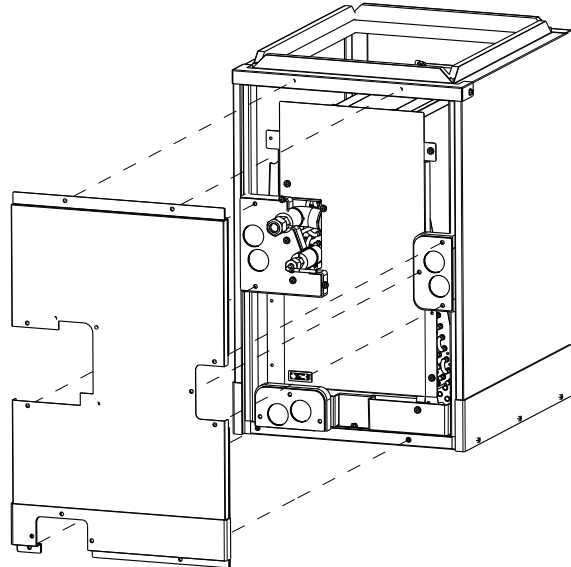

Step 21: Replace pipe panel (using the 5 screws).

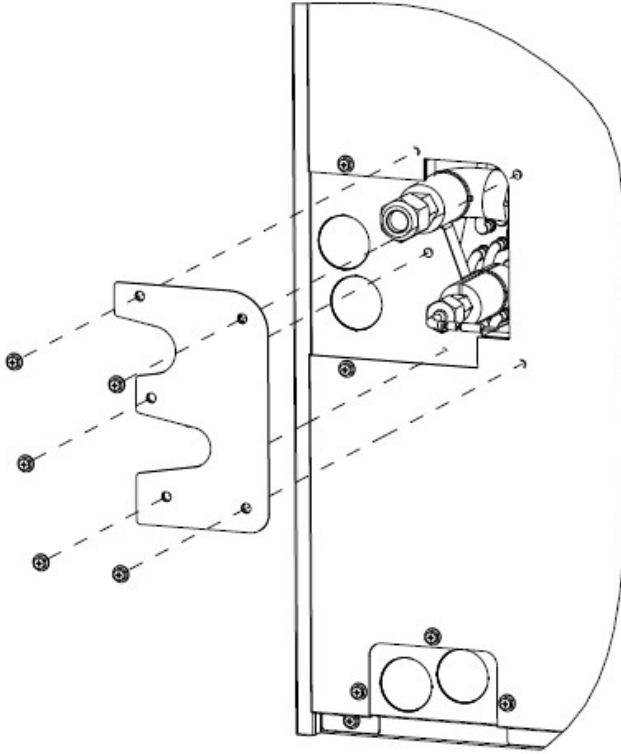

⚠ CAUTION

Auxiliary drain pan requirement

An auxiliary drain pan without a separate drain line shall be installed under the furnace. The pan must have a minimum depth of 1.5 inches (38 mm), be not less than 3 inches (76 mm) larger than the unit or the coil dimensions in width and length and must be constructed of corrosion-resistant material. Galvanized sheet steel pans must have a minimum thickness of not less than 0.0236-inch (0.6010 mm). (Do not use 24 gauge.) Non-metallic pans must have a minimum thickness of not less than 0.0625 inch (1.6 mm). This pan must be equipped with a water level detection device conforming to UL 508 that will shut off the equipment served prior to overflow of the pan. The pan must be equipped with a fitting to allow for drainage.

10.3. Horizontal left installation

To remove the heat exchanger from the cabinet, perform **steps 1-10** detailed in "Upflow/Downflow installation" section.



NOTE

Side drain pan must be relocated for horizontal left installations.

Step 1: Remove and discard (recycle) the top left Z-bracket. Remove the 2 triangular pieces from the heat exchanger assembly.

CAUTION
 When moving from right to left install position, the front triangular piece, distinguishable with a V-notch on one edge, remains in front of the heat exchanger assembly and the back triangular piece remains at the back of the assembly. Failure to do so can result in condensate drainage problems.

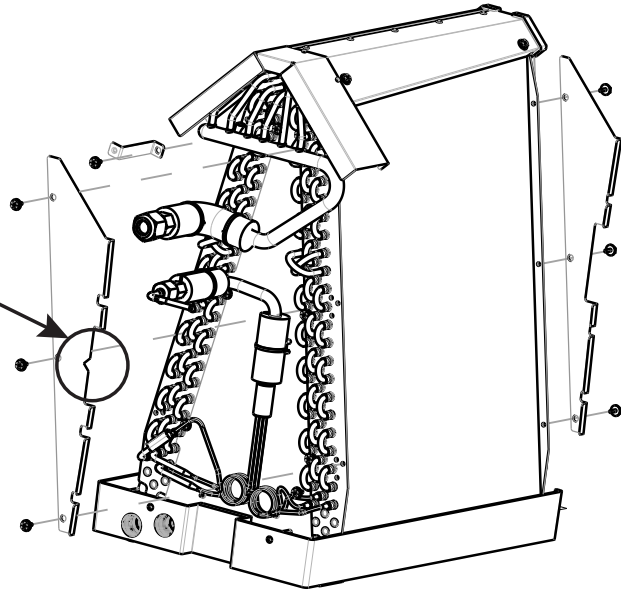

Step 2:

A) Install the 2 triangle pieces on the left side of the heat exchanger assembly.

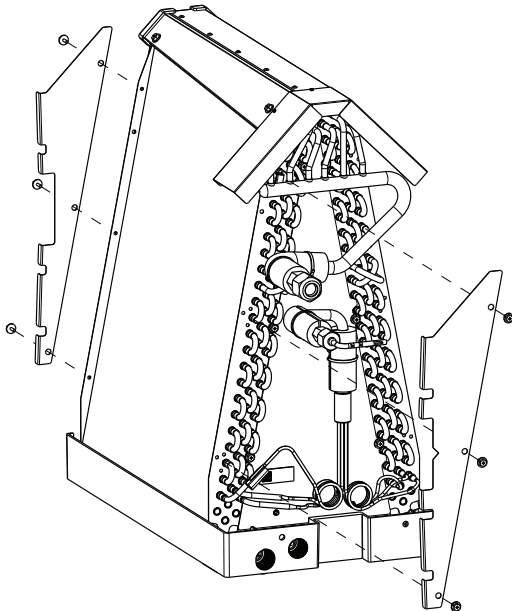

B) For PAA-A18 models, remove top drain and install to the other side as shown.

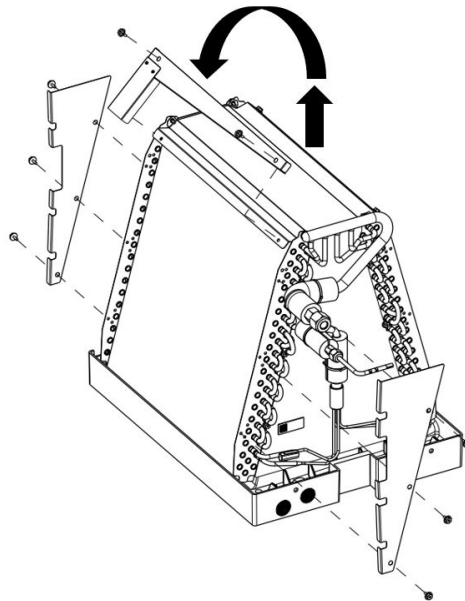

Step 3: Insert the side drain pan to the left hand side of the main drain pan as shown below.

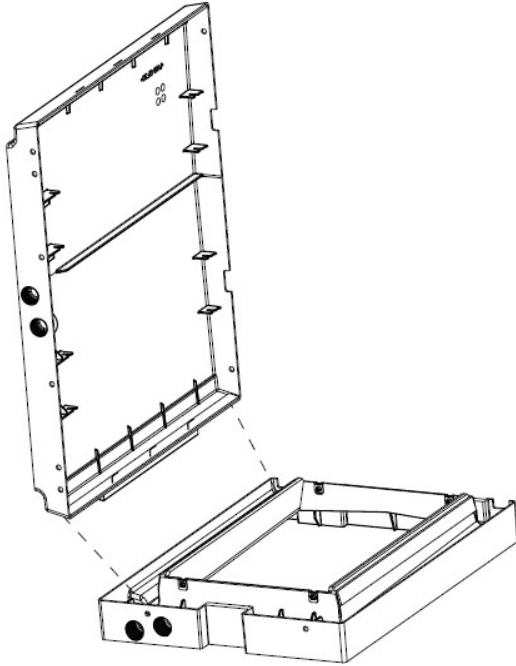

Step 4: Attach the heat exchanger to the main drain pan with the 4 screws.

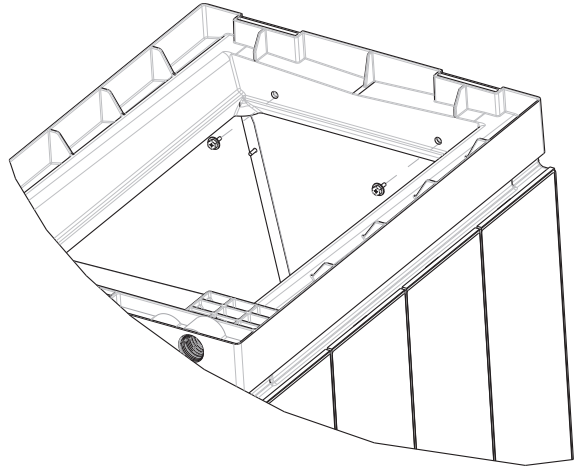

PAA unit inverted to show how the 4 screws are installed.

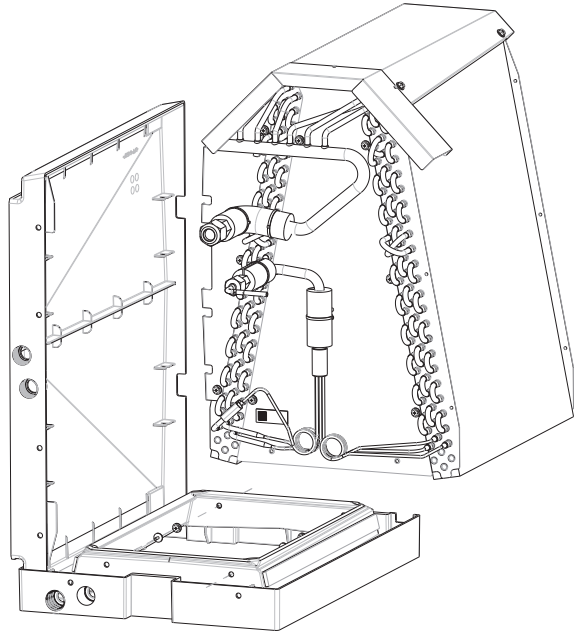

Step 5: Attach the front plate to the main drain pan using the 4 screws.

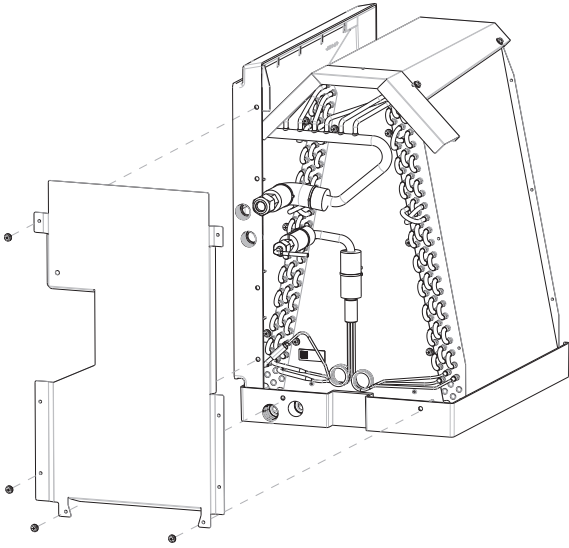

Step 6: Insert the heat exchanger back into the cabinet. Ensure the notches in the back of the main drain pan engage with the two rear brackets inside the cabinet.

⚠ CAUTION

- Use extreme caution when inserting the heat exchanger back into the cabinet to avoid damaging the thermistor wires.
 - Damaged thermistor wires may result in improper or dangerous operation of the unit.

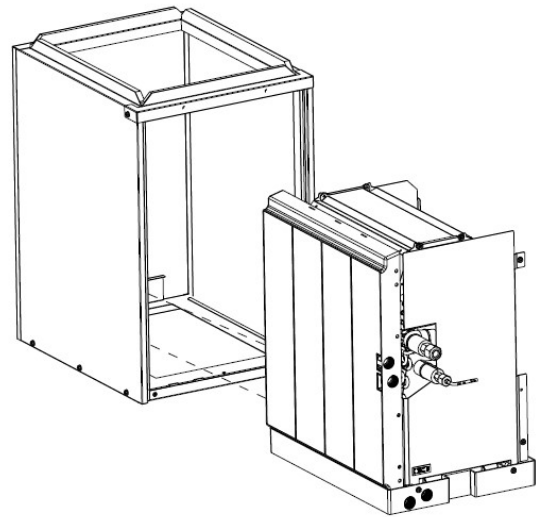

Step 7: Replace the side drain pan support bracket.



NOTE

Side drain pan support bracket must be installed using the 2 holes closest to the rear of the cabinet while the heat exchanger is inside the cabinet. Some parts are not shown for clearer image.

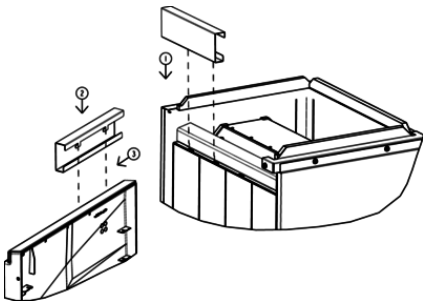

Step 8: Use screw (1) to install the front Z-bracket to secure the heat exchanger to the cabinet.

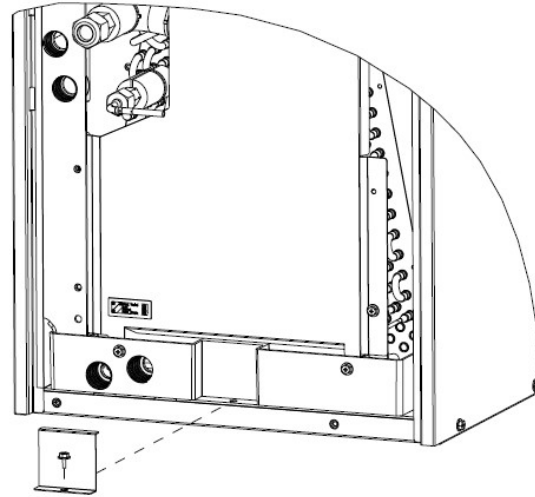

Step 9: Replace the 2 side panels (side pipe panel assembly).

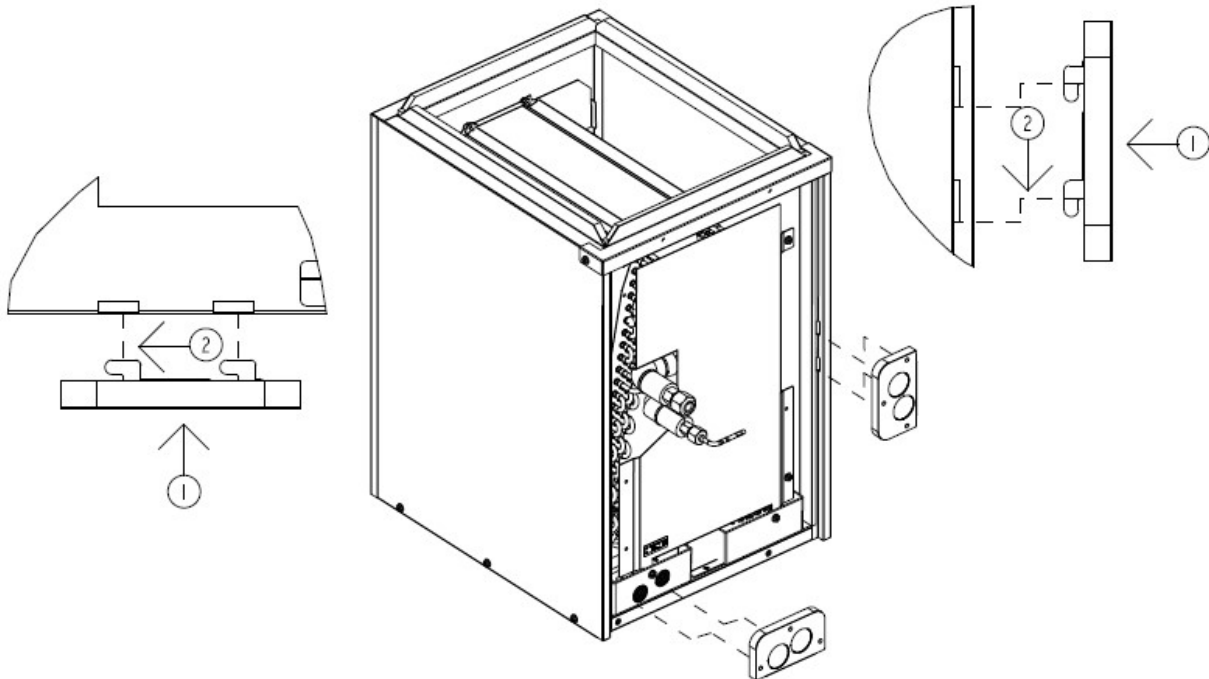

Step 10: Replace the pipe panel (main pipe panel).

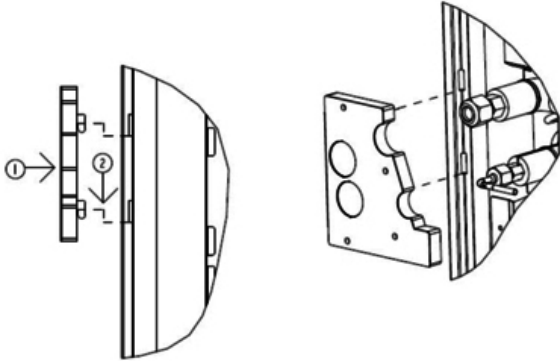

Step 11: Replace the front panel using the 12 screws. (Screws not shown.)

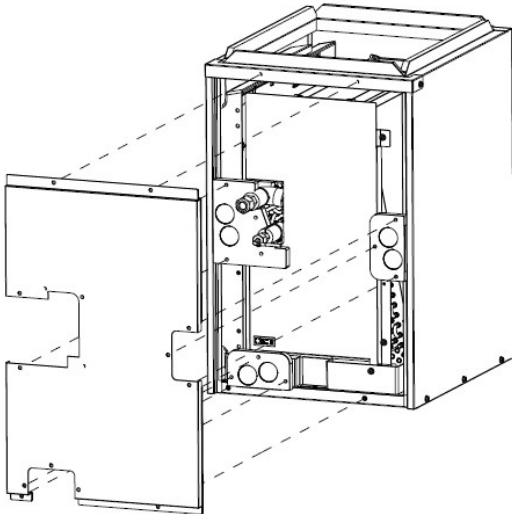

Step 12: Replace pipe panel (using the 5 screws).

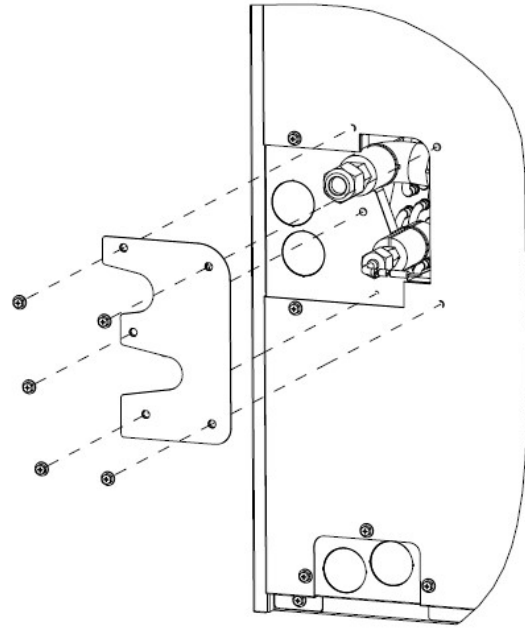

⚠ CAUTION

Auxiliary drain pan requirement

An auxiliary drain pan without a separate drain line shall be installed under the cabinet of the PAA unit. The pan must have a minimum depth of 1.5 inches (38 mm), be not less than 3 inches (76 mm) larger than the unit or the coil dimensions in width and length and must be constructed of corrosion-resistant material. Galvanized sheet steel pans must have a minimum thickness of not less than 0.0236-inch (0.6010 mm). (Do not use 24 gauge.) Non-metallic pans must have a minimum thickness of not less than 0.0625 inch (1.6 mm). This pan must be equipped with a water level detection device conforming to UL 508 that will shut off the equipment served prior to overflow of the pan. The pan must be equipped with a fitting to allow for drainage.

10.4. Horizontal right installation

The PAA unit is shipped from the factory for horizontal right configuration, no further changes are required.

If the heat exchanger assembly is removed, please follow **steps 1-10** (Vertical orientations- see "Up-flow/Downflow installation" section) in reverse order to replace the heat exchanger back in the cabinet.



CAUTION

Auxiliary drain pan requirement

An auxiliary drain pan without a separate drain line shall be installed under the cabinet of the PAA unit. The pan must have a minimum depth of 1.5 inches (38 mm), be not less than 3 inches (76 mm) larger than the unit or the coil dimensions in width and length and must be constructed of corrosion-resistant material. Galvanized sheet steel pans must have a minimum thickness of not less than 0.0236-inch (0.6010 mm). (Do not use 24 gauge.) Non-metallic pans must have a minimum thickness of not less than 0.0625 inch (1.6 mm). This pan must be equipped with a water level detection device conforming to UL 508 that will shut off the equipment served prior to overflow of the pan. The pan must be equipped with a fitting to allow for drainage.

11. Refrigerant piping work



NOTE

For constraints on refrigerant piping lengths and allowable differences in elevation, refer to the design section of the ODU engineering manual.

For information about maximum total piping lengths for PAA series connections, see "PAA-series Connection" in the "Before getting started" section.

The method of pipe connection on the PAA unit is flare connection.

Provide proper bracing for refrigerant piping so no load is imparted upon the connections at the PAA unit.



WARNING

- Always wear safety glasses when working around pressurized devices.
 - Failure to follow safety requirements can result in injury or death or building damage.



CAUTION

- When installing or moving the unit, do not charge it with refrigerant other than the refrigerant specified on the unit.
 - Mixing of a different refrigerant, air, etc. may cause the refrigerant cycle to malfunction and result in severe damage.
- Use refrigerant piping made of C12200 (Cu-DHP) phosphorus deoxidized copper as specified in the ASTM B280 Standard Specification for Seamless Copper Tube for Air Conditioning and Refrigeration Field Service. In addition, be sure that the inner and outer surfaces of the

pipes are clean and free of hazardous sulphur, oxides, dust/dirt, shaving particles, oils, moisture, or any other contaminant. Never use existing refrigerant piping.

- The PAA units are shipped with a nitrogen holding charge in the coil. Carefully remove the flare nut off the end of the pipe to release any gas.
- Both refrigerant lines need to be insulated all the way up to the cabinet. Make sure the open-

ings in the cabinet around the refrigerant lines are sealed. 3/8 inch thick insulation is the minimum recommended thickness. Based on ambient conditions, local codes and line length, thicker insulation may be required.

- When connecting new refrigerant lines, do not put any oil on the threaded portion of the flare nuts. This may cause the flare nut to loosen and leak refrigerant.

| Piping Details | | | | |
|----------------------------|----------|---|--------------------------|-----------------------|
| Pipe diameter inch (mm) | Nut (mm) | A inch (mm) Clutch type tool for R410A | Tightening torque N*m | lb*ft (kgf*cm) |
| 1/4 (6.35) | (17) | 0 to 0.02 (0 to 0.5) | 13.7 to 17.7 | 10 to 13 (140 to 180) |
| 3/8 (9.52) | (22) | | 34.3 to 41.2 | 25 to 30 (350 to 420) |
| 1/2 (12.7) | (26) | | 49.0 to 56.4 | 36 to 42 (500 to 575) |
| 5/8 (15.88) | (29) | | 73.5 to 78.4 | 54 to 58 (750 to 800) |

Refrigerant pipe processing

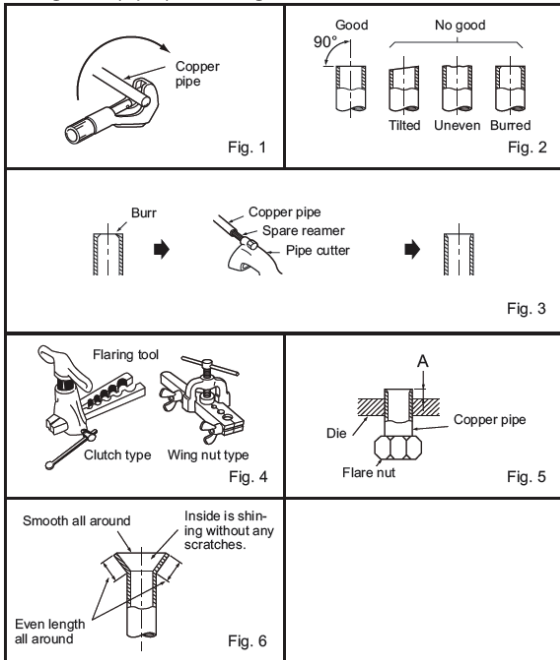

Apply proper torque to flare nuts.

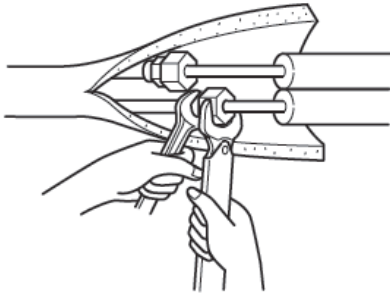

- Store the piping to be used during the installation indoors and keep both ends of the piping sealed until just before installing it.
- If dust, dirt or water gets into the refrigerant cycle, the oil will deteriorate and the compressor may fail.

- Use refrigerant oil to coat flares and flange connections before connecting.
- Refrigerant oil is highly hygroscopic and if it absorbs moisture from the air, will degrade the refrigerant and contaminate the system.

11.1. Insulation of refrigerant lines

To avoid condensation, provide sufficient anti-sweating insulation to the refrigerant pipes and drain pipes. When using commercially available refrigerant pipes, be sure to cover them with insulating material with a heat-resistant temperature rating of more than 212° F (100° C). The recommended thickness of the insulation can be found in the chart below. This applies to both the liquid and gas pipes. Insulate all indoor pipes with polyethylene insulation with a minimum density of 0.03 g/cm³ [2.0 LB/ft³] and a thickness as specified in the table below.

| Pipe size | Insulation thickness |
|---|----------------------|
| 6.4 mm to 25.4 mm [1/4 to 1 in] | > 10 mm [7/16 in] |
| 28.6 mm to 38.1 mm [1-1/8 to 1-1/2 in] | > 15 mm [5/8 in] |



NOTE

If the unit is used on the highest story of a building and under high temperature and high humidity, it is necessary to use thicker insulation than specified in the table above.

11.2. Piping size

| Model | Liquid pipe | Gas pipe | Drain pipe |
|-----------------------------|-------------------|-------------------|-------------|
| PAA-A18AA1/BA1 ¹ | 1/4" ² | 1/2" ³ | 3/4" PVC |
| PAA-A24/30AA1/BA1 | 3/8" | 5/8" | |
| PAA-A36/42BA1/CA1 | | | |

¹When PUZ or PUY outdoor unit is connected, please use 3/8" x 5/8" lineset.

²When PUZ or PUY outdoor unit is connected, please use 3/8" pipe size with PAC-493PI for the liquid pipe.

³When PUZ or PUY outdoor unit is connected, please use 5/8" pipe size with MAC-A456JP-E for the gas pipe.

12. Drain connections

Finger-tighten the drain pan connections plus two turns, but no more than plus two and a half turns. Make sure to use a sealant for threaded joints. Use a sealant that is non-hardening, compatible with plastic, and effective in temperatures up to 250° F (121° C).

CAUTION

- **Over-tightening the drain connections could result in drain pan breakage and failure.**
- Use of any type of sealant other than specified above might lead to leakage.

The PAA unit contains two sets of 3/4" FPT drain connections. One set of connections is to be used when mounting the unit vertically and the other is used when mounting horizontally. Each set contains a primary drain and a secondary drain. The primary drain is the one that is lowest (even with the bottom of the pan). The secondary drain is at the higher level. They are labeled on the dimensional drawings described in the "Dimensions" section.

These units operate with a positive pressure at the drain connections, and although a P-trap is not required, it is recommended to prevent capacity loss. Always follow local codes and standards.

- The trap needs to be installed as close to the unit as possible. Make sure the top of the trap is below the connection to the drain pan to allow complete drainage of the pan.

- Slope the drain line a minimum of 1/4" per foot.

- Do not reduce the pipe size from 3/4", this could cause premature blockage in the lines.

- Do not braze near the plastic drain piping.

NOTE

Using an oversized drain connection fitting could cause an interference with the cabinet side panel.

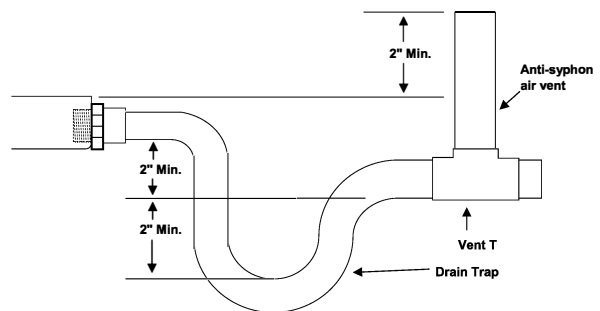

Vertical mounting:

When mounted vertically, the air handler's primary drain connection is located in the center of the unit.

The slightly higher drain to the left is the secondary drain. Attach the drain connector and properly tighten with sealant and install the drain line.

CAUTION

Over-tightening the drain connection could result in drain pan breakage and failure. The secondary connection is for the overflow switch (provided in the accessories bag). This device will shut the cooling operation down in the event of a primary drain line blockage. See wiring section for connecting this device.

Horizontal mounting (left or right):

If the unit is installed horizontally, remove the knock-out in the front panel to gain access to the side drain pan connections. Attach the connector as described above and route drain line. Any vertical drain pan openings must be covered to eliminate air loss which will decrease the capacity of the unit.

CAUTION

Over-tightening the drain connection could result in drain pan breakage and failure. The secondary connection is for the overflow switch (provided in the accessories bag). This device will shut the cooling operation down in the event of a primary drain line blockage. See wiring section for connecting this device.

NOTE

Horizontal runs must also have an anti-siphon air vent (standpipe) installed ahead of the horizontal run to eliminate air trapping. Horizontal drain lines must be pitched a minimum 1/4" per foot. Route the drain lines outside or to an appropriate drain. Drain lines must be installed so they do not block service access to the front of the unit. 24" clearance in the front is for routine maintenance or service.

NOTE

Check local laws and regulations before connecting the drain line to an existing drainage system. Insulate the drain pipe where condensate water may cause damage. Once the installation is complete, it is the installer's responsibility to ensure that the drain pan captures all condensate water and that all condensate water is properly drained and does not enter the duct / system.

CAUTION

- Drain pipe must be installed in accordance with gas furnace install manual instructions. Mitsubishi Electric US, Inc. is not responsible for any damage caused by integrated drain pipe work carried out between the gas furnace and the PAA unit.

CAUTION

Auxiliary drain pan requirement

An auxiliary drain pan without a separate drain line shall be installed under the cabinet in horizontal left/right and under the furnace in vertical upflow/downflow PAA unit installations. The pan must have a minimum depth of 1.5 inches (38 mm), be not less than 3 inches (76 mm) larger than the unit or the coil dimensions in width and length and must be constructed of corrosion-resistant material. Galvanized sheet steel pans must have a minimum thickness of not less than 0.0236-inch (0.6010 mm). (Do not use 24 gauge.) Non-metallic pans must have a minimum thickness of not less than 0.0625 inch (1.6 mm). This pan must be equipped with a water level detection device conforming to UL 508 that will shut off the equipment served prior to overflow of the pan. The pan must be equipped with a fitting to allow for drainage.

13. Float switch

! IMPORTANT

Float switch is required for all PAA unit installation orientations.

In order to protect the gas furnace from corrosion, Mitsubishi Electric US, Inc. requires installing a float switch. If the float switch is not installed, Mitsubishi Electric US, Inc. is not responsible for any damage to the furnace.

Inspect the float switch for damage. If damaged, obtain a replacement before continuing the installation.

NOTE

The float switch must be installed for proper system operation. An error code will result if the switch is not installed.

The float switch, also called the AC safety switch, is an electronic water sensor for your HVAC system. It gives the AC system the ability to detect water backing up into the drain pan, possibly indicating a clogged drain. The float switch will shut the system off if the water level reaches a certain point.

The float switch is installed in the secondary drain line of the air conditioner, and if water begins to accumulate in the drain line, the ball inside the switch will begin to float. When the ball floats to the top of the drain line, the switch will transmit a signal to the PAA unit to turn off, preventing an overflow.

The float switch is included in the accessory bag indicated as item #1 in the "Indoor unit accessories" section.

NOTE

Float switch installation is shown for PAA unit vertical orientation.

Step 1: The float switch assembly contains the following components:

- SS2 cap assembly (with float and wire)
- SS2 housing
- SS2 coupling

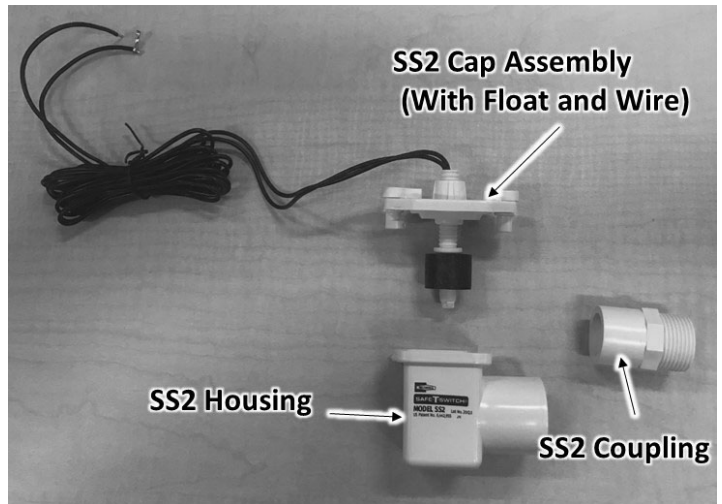

Step 2: Ensure the float switch water detect level is 3 rings high. This indicates the float switch install level is correct and does not require further adjustment.

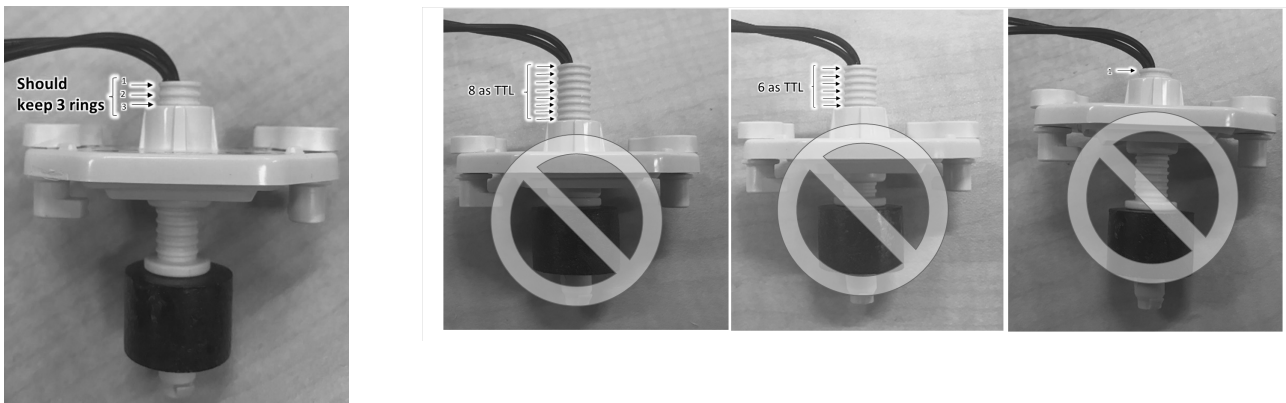

Step 3: Install the switch in the drain pan, as indicated below. Utilize the cut out gauge (provided in the "Cut out gauge" chapter) to ensure float switch is level.



NOTE

When SS2 cap is attached to SS2 housing, ensure the two cam locks are in the lock position as described in the SS2 installation manual.

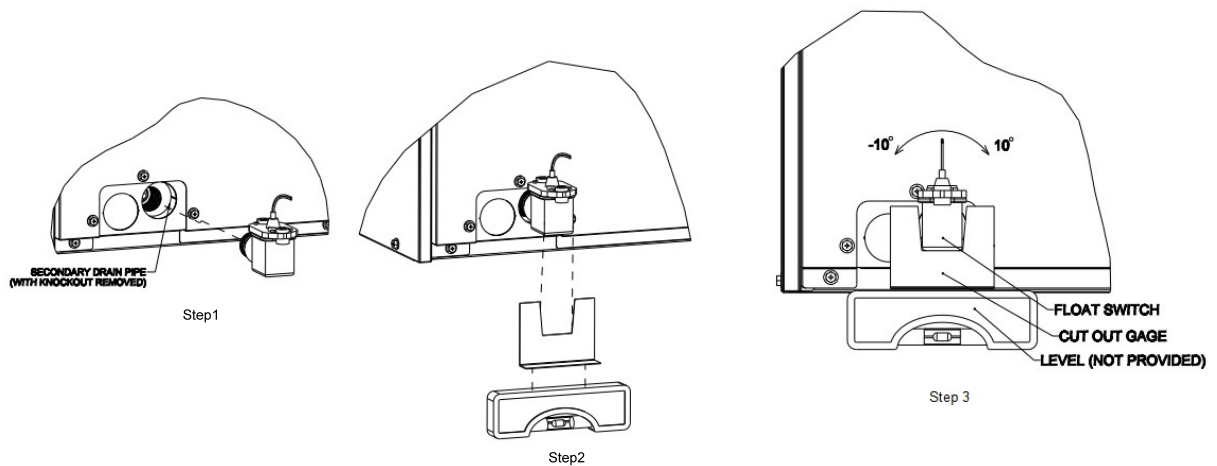

IMPORTANT

Ensure the stem is as vertical as possible, angled no more than 10 degrees from vertical orientation.

In order for proper float switch operation, check the float switch is oriented as shown in the image above. Use a level to ensure the float switch is oriented properly as shown.

Step 4: Connect the float switch wire to CN4F in the control panel, as shown in "Condensate overflow safety switch connection (CN4F)" section.

CAUTION

When installing the float switch, consider the following potential water leakage issues:

- between the SS2 housing and SS2 coupling
- between the drain pan screw and SS2 coupling

Refer to www.rectorseal.com for float switch WARNING, CAUTION and NOTICE, prior to float

switch installation. Float switch is made of PVC . Extremely high furnace discharge temperature may cause damage to the float switch. Mitsubishi Electric US, Inc. is not responsible for float switch damage caused by gas furnace heat.

If extension is added to the drain pipe, ensure that the float switch can safely detect overflow conditions. If float switch water detection level is higher than drain pan overflow level, Mitsubishi Electric US, Inc. is not responsible for water leak or gas furnace damaged problems, caused by water leak from the PAA unit.

14. Installing the control box

The primary function of the control box is to control the operation of a heating and air conditioning system.

The control box is shipped with the PAA unit and can be installed on the cabinet as shown below or externally (not attached to the cabinet) at a location designated by the customer.

If installed on the cabinet, control box must be installed in the designated location, depending on the PAA unit orientation.

NOTE

Recommended control box orientations on the cabinet as shown below.

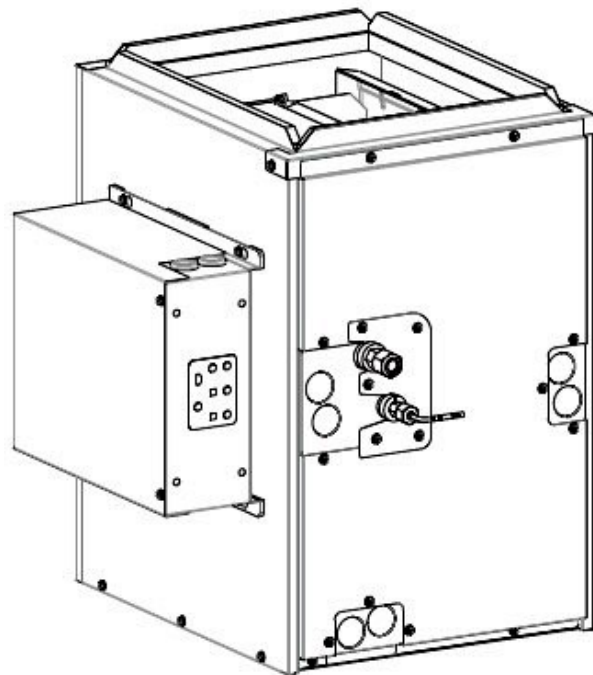

14.1. Control box - cabinet installation

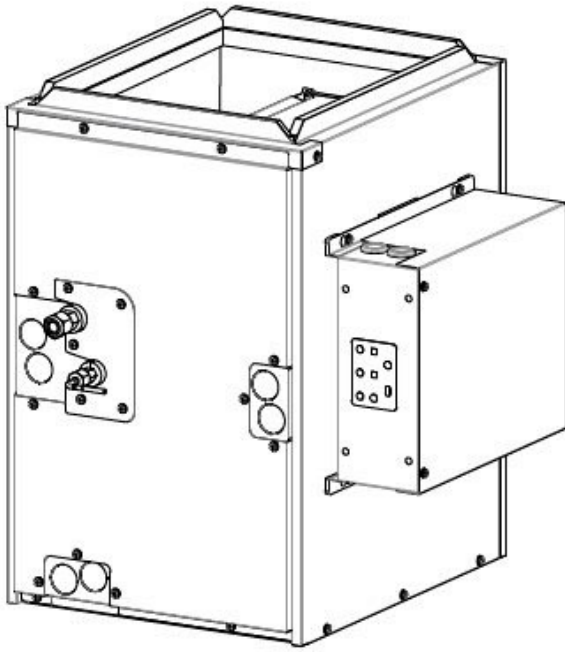

NOTE

- Control box can be mounted on the left or right side of the cabinet. Regardless, the control box positioning dimensions are the same.
- For environments when the ambient dew point temperature exceeds 73° F (23° C), if the control box must be mounted to the PAA unit cabinet, be sure to perform appropriate treatment to the PAA unit cabinet, such as duct wrap, **prior** to attaching the control box to the PAA unit cabinet.

The following must be considered while deciding on a location to install the control box:

- Control box must be installed at least 1 inch from the edge of the surface, as shown below.
- The surface must be flat without any cutouts or depressions.

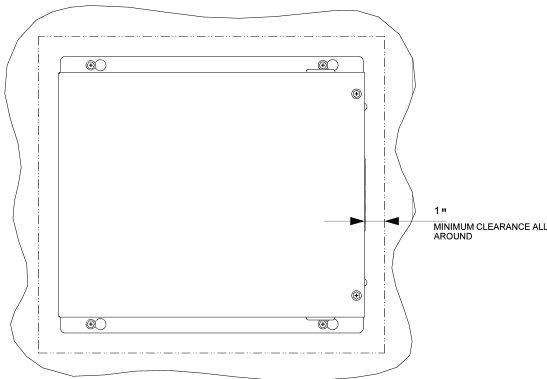

Secure the control box with the M5 screws provided in the accessories bag by drilling four 3/16" pilot holes as shown in the allowed area below. Place washers, provided in accessories bag, between the control box and cabinet.

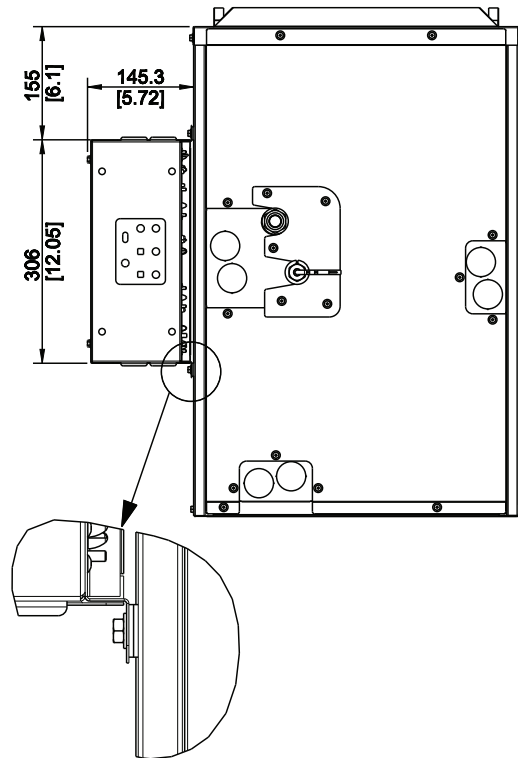

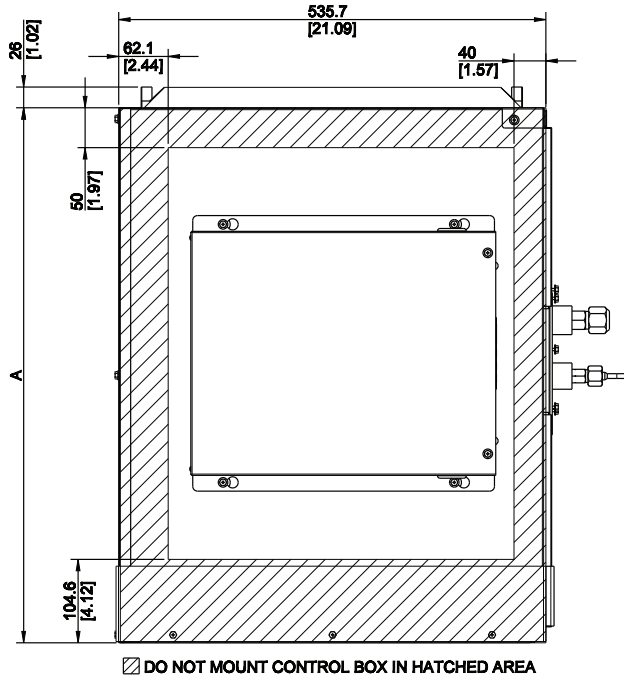

| | "A" |
|--|-----------------------|
| PAA-A18AA PAA-A18BA PAA-A24AA PAA-A24BA PAA-A30AA PAA-A30BA | 671 MM 26-7/16 IN |
| PAA-A36BA PAA-A42BA PAA-A36CA PAA-A42CA | 786 MM 30-15/16 IN |

14.2. Control box - external installation

If the control box is to be installed on an alternative location, it is the responsibility of the installer to secure the control box properly and ensure all wiring between the control box and cabinet reaches and is secure. The distance between the cabinet and control box is limited by the length of the thermistor cables (approximately 3 meters) that come installed on the cabinet. Please consider this when locating the control box from the cabinet.

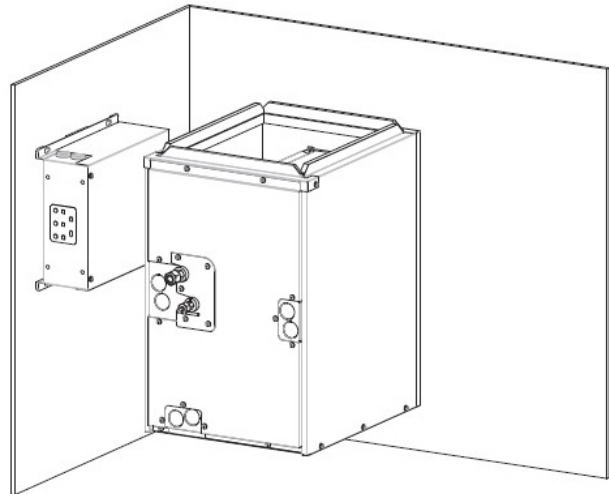

NOTE

- Match drill holes (4) per layout.
- Only drill through the sheetmetal. Drilling any further can damage the coil.
- Washers, provided in accessories bag, must be installed between control box and cabinet to create a gap between the control box and cabinet.



CAUTION

When the ambient dew point temperature exceeds 73° F (23° C), dew condensation may occur on the PAA unit surface. Without a gap between the control box and PAA unit cabinet, dew condensation may enter the control box which may result in unit damage or failure.

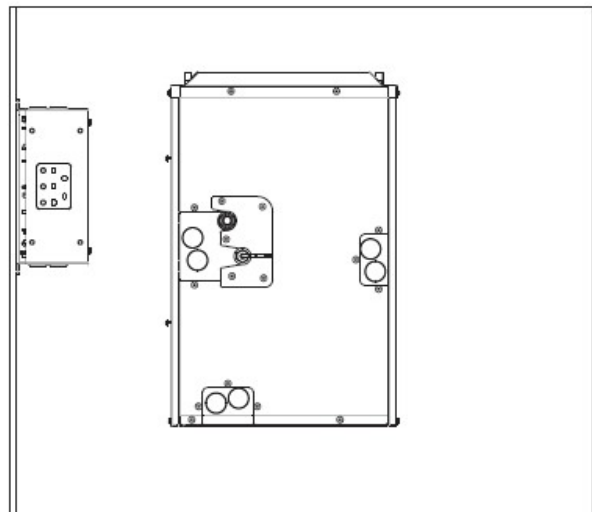

15. Electrical wiring

15.1. Warning and caution

WARNING

Electrical work should be done by a licensed dealer, contractor, or electrician in accordance with all local and national codes, and supplied installation manuals. If the power circuit lacks capacity or has an installation failure, it may cause a risk of electrical shock or fire.

- Install the unit in a manner that prevents direct contact between any of the control circuit cables (remote controller, transmission cables) and the power cable outside the unit.
- When sizing wire and completing electrical connections during installation, please follow local codes and standards. Secure the connections so that the outside force of the cable is not applied to the terminals.
- Never connect high voltage power cables to low voltage control, communication, or signal lines.

- Be sure to connect control cables to the indoor unit, remote controller and the outdoor unit.
- Before installation, please ensure that the furnace is properly grounded.
- Use relays or switches with IEC or equivalent standard.

WARNING

Be sure to ground the PAA unit cabinet and control box according to local code. Do not connect the grounding cable to any gas pipe, water pipe, lightning rod or telephone earth cable. Incomplete grounding may cause a risk of electrical shock. If the power supply wiring is damaged, it must be replaced by the manufacturer, service personnel or licensed persons in order to avoid a hazard.

15.2. Connecting line voltage

WARNING

Ensure that you comply with the following requirements. Otherwise, results such as electric shock, fire or explosion may occur.

- **MAKE SURE POWER SUPPLY IS OFF.**
- The unit should be installed by a licensed contractor/electrician. If required by applicable national, state, and local codes, a disconnect switch will need to be installed when the indoor unit is powered from the outdoor unit.
- The disconnect switch should **ALWAYS** be disconnected while installing the system.
- Do not use anything other than the correct capacity breaker and fuse. Using fuse, wire or copper wire with too large capacity may cause a risk of malfunction or fire.
- Wire the power supply so that no tension is imparted. Otherwise disconnection, heating or fire may result.

Remark: * Use ring terminals for all ground connections.

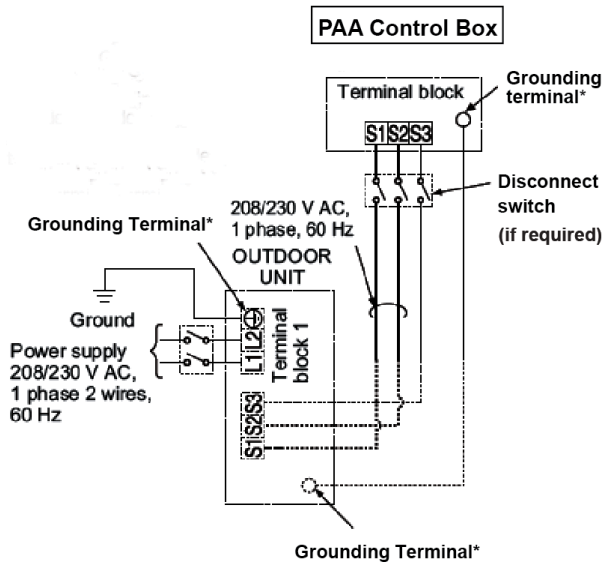

NOTE

All wiring must conform to national and local codes.

Step 1: Remove the desired knockout on the control box.

Step 2: Attach a conduit pipe connector to the control box and route the wiring as shown in the above diagram. Ensure that the conduit connection hole is airtight; add a sealant if necessary.

Step 3: Firmly tighten all of the terminal screws. After tightening, verify that the wires are tightly fastened.

15.3. Function settings

| Mode | Mode no. | Settings | Setting no. | Initial setting |
|----------------------------|--------------------------------|-------------------------------------|-------------|-----------------|
| Power failure auto restart | 1 | Not enabled | 1 | 1 |
| | | Enabled | 2 | |
| Indoor temperature reading | 2 | Indoor unit operating average | 1 | 1 |
| | | Indoor unit's internal sensor | 2 | |
| | | Remote controller's internal sensor | 3 | |
| Power voltage | 4 | 240V (230V) | 1 | 1 |
| | | 220V (208V) | 2 | |
| Filter sign | 7 | 100 Hr | 1 | 3 |
| | | 2500 Hr | 2 | |
| | | No filter sign indicator | 3 | |
| Humidifier control | 13 | Humidifier not supported | 1 | 2 |
| | | Humidifier supported | 2 | |
| | 16 (applies if Mode 13 = 2) | Heat mode & Thermo ON | 1 | 1 |
| | | Heat mode | 2 | |

| Mode | Mode no. | Settings | Setting no. | Initial setting |
|------------------------|-----------------|---|----------------|-----------------|
| 1-speed or 2-speed fan | 23 ¹ | Fan speed output signals G and Y to furnace | 1 ² | 1 |
| | | Fan speed output signals Y1 and Y2 to furnace | 2 ³ | |

¹After changing Mode 23 setting, you need to power cycle the system for the change to reliably take effect.

²If connecting to a furnace with only one fan speed for cooling represented by Y, set Mode 23 = 1.

³On furnaces that have Y1 and Y2, using the 2-speed mode (Mode 23=2) utilizes two fan speeds while heating or cooling with the heat pump. These furnaces may also be configured for one fan speed operation (Mode 23=1) during heating and cooling with the heat pump which only turns on G in Dry mode, lowering the fan speed and removing more humidity in Dry mode.

15.4. PAA unit control box

Control box components

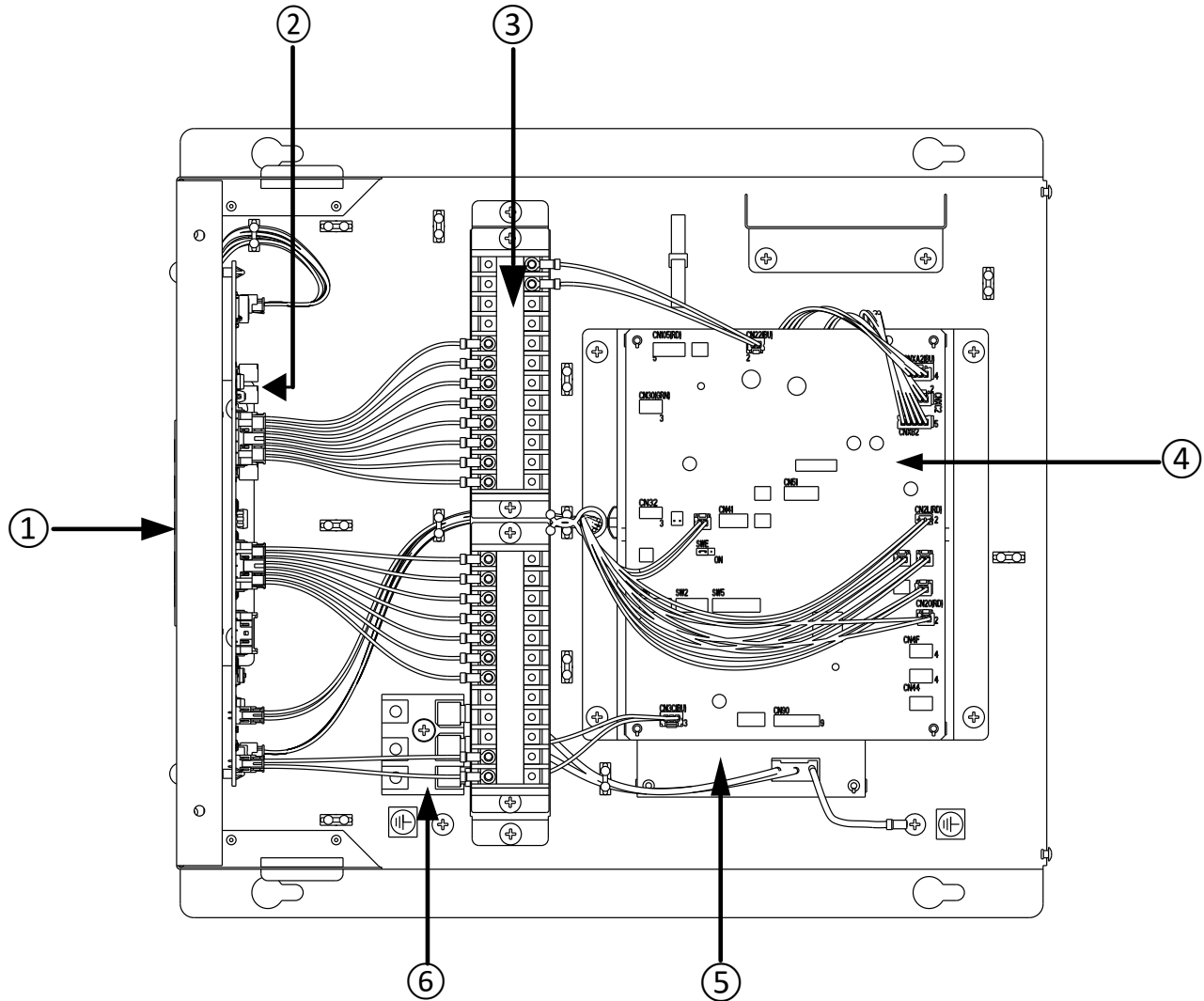

- ① User interface
- ② Relay board
- ③ Terminal blocks

- ④ Control board
- ⑤ Power board (underneath the control board)
- ⑥ AC input terminal block

Field-installed connections

- The TH02 and TH05 thermistor wires from the IDU coil must be plugged in to the CN44 connector on the control board.
- The TH01 thermistor wires must be connected to connections 23A and 24A on the terminal block in the PAA unit control box.

(See the following "Field-installed connections" and "Terminal block pins (out)" images.)

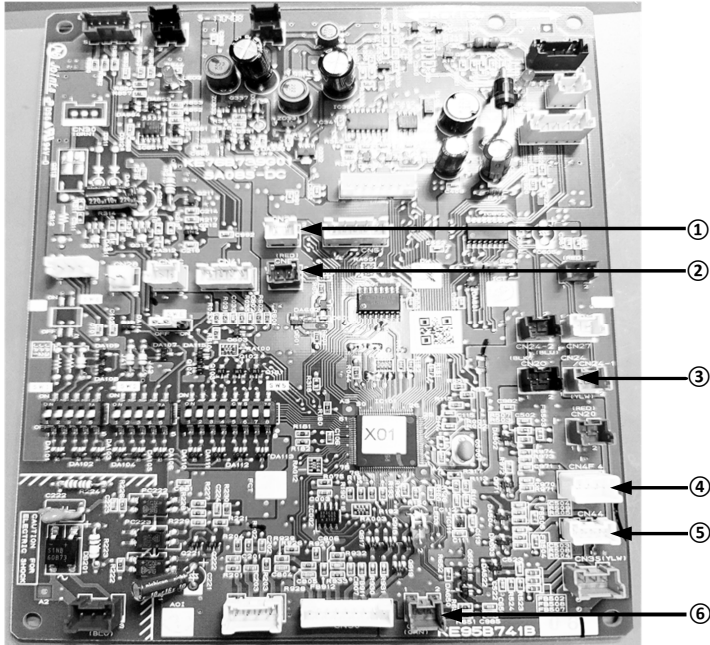

- ① CN25: Humidifier output (connector color: white)
- ② CNER: ERV input (connector color: red)
- ③ CN2C: ERV output (connector color: black)
- ④ CN4F: Float switch (connector color: white)
- ⑤ CN44: TH02 and TH05 pipe temperatures (connector color: white)
- ⑥ CNF: Humidifier input (connector color: green)

Terminal block pins (out)

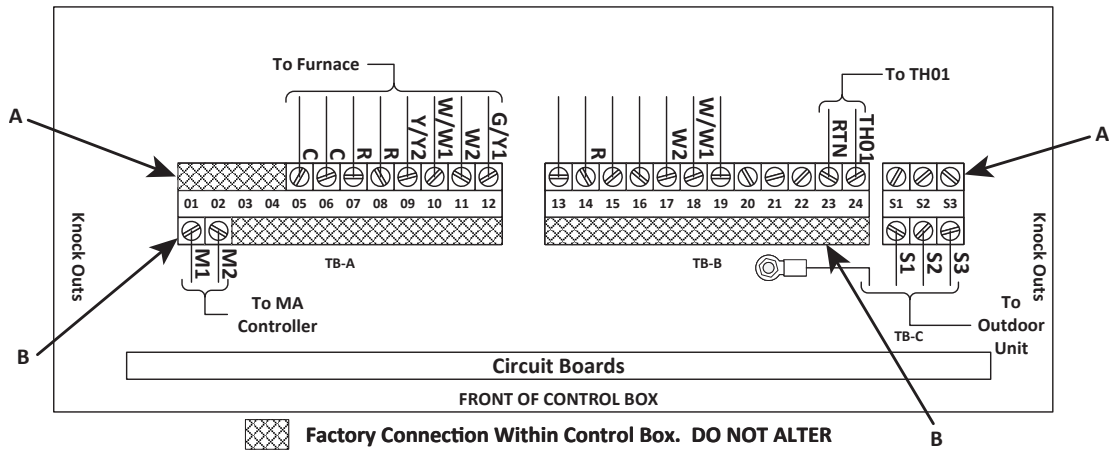

| Pin | Signal | Pin | Signal |
|-------|--|--------|---|
| 1B | MA communication bus M1. Wire color: blue (CN22) | 13A | Unused |
| 2B | MA communication bus M2. Wire color: white (CN22) | 14A | Signal R to non-adjustable thermostat (NAT) (24 VAC hot) Wire color: red |
| 3 A/B | Unused | 15A | Unused |
| 4 A/B | Unused | 16A | Unused |
| 5A | Signal C to furnace (24VAC return). Wire color: light blue, cyan or black | 17A | Signal W2 to optional connection to NAT (may be connected to W1 to turn on both stages of furnace when requested by the NAT) (second stage of heating). Wire color: brown |
| 6A | Same as 5A | 18A | Signal W1 to NAT (first stage of heating). Wire color: white |
| 7A | Signal R to furnace (24VAC hot). Wire color: red | 19A | Unused |
| 8A | Same as 7A | 20 A/B | Unused |
| 9A | Signal Y/Y2 to signal Y (wire color: yellow) of furnace on 1-speed fan or to signal Y2 (wire color: blue) of furnace on 2-speed fan. | 21 A/B | Unused |
| 10A | Signal W1 to furnace (first stage of heating). Wire color: white | 22 A/B | Unused |
| 11A | Signal W2 to furnace (second stage of heating). Wire color: brown | 23A | RTN (return air temperature sensor). Wire color: white |

| Pin | Signal | Pin | Signal |
|-----|--|-----|---|
| 12A | Signal G/Y1 to signal G (wire color: green) of furnace on 1-speed furnace or to signal G and Y1 (wire color: yellow) on 2-speed furnace. | 24A | TH01 return air temperature sensor). Wire color: black |

| Lines from outdoor unit to indoor unit | Description |
|--|---|
| Terminal S1 | Main power input line for the indoor unit from the outdoor unit. |
| Terminal S2 | Return or neutral line for the indoor unit from the outdoor unit. |
| Terminal S3 | Communication line between outdoor unit and indoor unit. |

15.5. Control signals to the furnace

Control signals to the furnace are the standard thermostat control signals R, C, W1, W2, Y/Y2 and G/Y1.

| Line/ Terminal/ Signal | Usage |
|------------------------------|---|
| R | Provides 24VAC power from the furnace to the relay board and a limited number of devices connected to the relay board (required AC input voltage range: 23 V _{RMS} to 30 V _{RMS}). |
| C | The 24VAC common wire between the furnace and the relay board. |
| W1 | First stage of furnace command line from the relay board to the furnace. |
| W2 | Second stage of furnace command line from the relay board to the furnace. W2 cannot be ON unless W1 is already ON. |
| G/Y1 | For 1-speed configuration (Mode 23 = 1), connect this signal to G of the furnace. For 2-speed configuration (Mode 23 = 2), connect this signal to G and Y1 of the furnace. The G/Y1 signal is energized in Cool, Dry, Heat or Fan modes whenever the fan is turned on. This signal is also energized, as configured, in coordination with the humidifier and ERV/HRV. |

| Line/ Termi- nal/ Signal | Usage |
|-----------------------------------|--|
| Y/Y2 | <p>For 1-speed configuration (Mode 23 = 1), connect this signal to the Y connection on the furnace. In this configuration, the Y/Y2 signal turns on when fan is requested while in Cool mode or Heat mode using the heat pump.</p> <p>For 2-speed configuration (Mode 23 = 2), connect this signal to Y2 on the furnace. In this configuration, the Y/Y2 signal turns on as follows:</p> <ul style="list-style-type: none"> • In Fan mode, Cool mode or Heat mode with heat pump when high speed fan is requested. • In Auto Fan¹ and Cool mode, the signal goes to high speed when the difference between room temperature and set point temperature is more than or equal to 4° F (2° C). The signal goes back to low speed when the temperature difference is less than 2° F (1° C). • In Auto Fan¹ and Heat mode with the heat pump, the signal goes to high speed when the difference between room temperature and set point temperature is more than or equal to 2° F (1° C) for 3 minutes. The signal goes back to low speed when the temperature difference is less than or equal to 1° F (0.5° C). |

¹Requires PUZ/PUY

To operate with the PAA unit, furnaces must have four minimum connections: R, C, W and G.

- On furnaces that only have a W and do not have a W2, connect W1 from the terminal block to the W of the furnace and make no connection with the W2 signal wire.
- On furnaces that do not have Y, configure for 1-speed mode and make no connection with the Y/Y2 signal wire. On furnaces that have Y (but not Y2), configure for 1-speed mode and connect G/Y1 to G of the furnace and Y/Y2 to Y of the furnace.
- On furnaces that have Y1 and Y2, using the 2-speed mode utilizes two fan speeds while heating or cooling with the heat pump. These furnaces may also be configured for one fan speed operation, which turns on only G in Dry mode, lowering the fan speed and removing more humidity in the Dry mode. To configure in 1-speed mode set mode 23=1 and connect G/Y1 to G of the furnace and Y/Y2 to Y1 and Y2 of the furnace. To configure in 2-speed mode set mode 23=2 and connect G/Y1 to G and Y1 of the furnace and Y/Y2 to Y2 of the furnace.



WARNING

Ensure that you comply with the following requirements. Otherwise, results such as electric shock, fire or explosion may occur.

- **Terminate all unused wires with individual wire nuts to prevent inadvertent short circuits.**
- **Do not connect the unused lines together or to anything else.**

15.6. PAA unit control options

- MA remote controller
- IT terminal connection options

15.6.1. MA remote controller

The PAA unit control board can be controlled by an MA remote controller. Connect the non-polarized wires from the remote controller to connections 1B and 2B on the terminal block in the control box. If the MA remote controller cable exceeds 32 ft

(10 m), use 16 AWG (1.25 mm²) diameter cable, not to exceed 656 ft (200 m) in length.

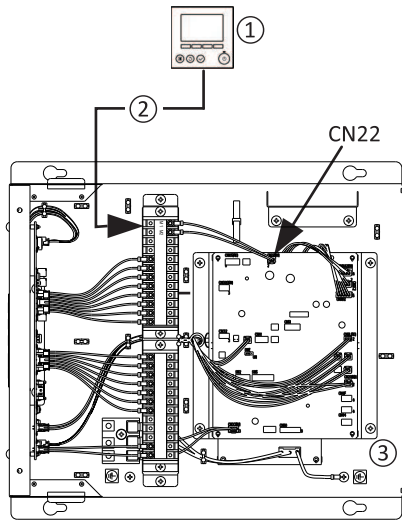

- ① MA remote controller (see also, section "Controller options".)
- ② MA wiring (connected to M1 and M2)
- ③ PAA unit control box

⚠ CAUTION

Ensure that the wiring is not pinched when fitting the control box cover. Pinching the wiring may cut it or cause an inadvertent short circuit.

⚠ CAUTION

Install wiring so that it is not tight or under tension. Wiring under tension may break or overheat and burn. Fix power source wiring to control box by using buffer bushing or minimal tensile force. (PG connection or the like.) Connect transmission wiring to transmission terminal block through the knockout hole of the control box using ordinary bushing.

⚠ CAUTION

Install wiring so that it does not touch the board or surrounding parts. Wiring that touches surrounding parts may be cut by long-term operation.

After wiring is complete, make sure again that there is no tension on the connections and attach the cover onto the control box in the reverse order of the removal. Also, seal any openings created from wiring into the control box. This will prevent air leakage.

⚠ IMPORTANT

If shielded wiring is used, attach ground on the outdoor unit's ground terminal.

15.6.2. Controller options

In addition to the MA remote controller, the PAA unit can also be controlled by one of the following devices connected to CN105 (IT terminal communications port).

- kumo cloud[®] app via Wireless Interface 2 (PAC-USWHS002-WF-2) or higher
- [MHK2](#) controller
- Combination of kumo cloud app and Wireless Interface with [MHK2](#) controller

📝 NOTE

The PAA unit is compatible with kumo cloud[®] app version 2.10 and above.

⚠ IMPORTANT

- Use care when installing the Wireless Interface. Make certain that it is outside the control box and away from metal surfaces which might interfere with the ability of the interface to communicate with the local wireless router.
- The system is designed to automatically use either the heat pump or the furnace. The user cannot control the heat pump or furnace manually.

📝 NOTE

Before installing or servicing the system, always turn off main power to the system.

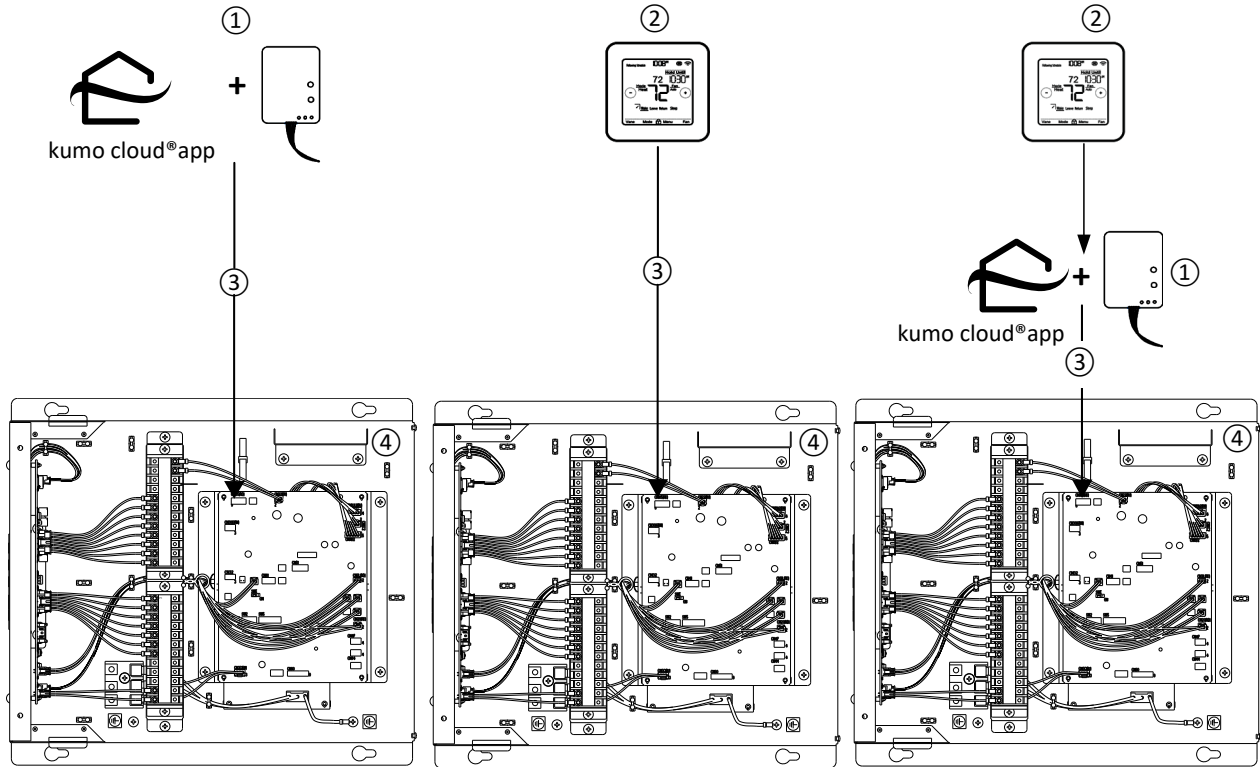

- ① kumo cloud app + Wireless Interface 2
- ② MHK2 controller
- ③ IT terminal cable (CN105: IT terminal communications port)
- ④ PAA unit control box

15.7. DIP switch for emergency thermostat

Using DIP switch SW01 settings on the relay board, you can select one of two modes—Test or Emergency—to operate in.

If DIP switch SW01-4 is set to ON, the PAA unit enters Test mode. While in Test mode, the installer can use the push buttons on the control box user interface to set W1 and W2 to ON or OFF. See the "Control box user interface" image below.

! WARNING

To ensure proper and safe operation of the unit, do not leave the home while the Test mode is running. Otherwise, results such as electric shock, fire or explosion may occur.

You can configure the initial (ON or OFF) state of the Test W1 and W2 heat signals in Test mode. Setting DIP switch SW01-2 to ON turns the Test W1 signal ON immediately once the furnace is powered on. Otherwise, the Test W1 signal will be OFF.

Setting DIP switch SW01-3 to ON turns the Test W2 signal ON immediately once the furnace is powered on. Otherwise, the Test W2 signal will be OFF.

Steps to check the furnace operation in Test mode:

- Step 1:** Power off system if not already off.
- Step 2:** Wait for 3 minutes; this ensures that the unit is completely powered down.
- Step 3:** Set SW01-4 to ON for Test mode.
- Step 4:** Turn the furnace breaker ON. Ensure that the outdoor unit system breaker is OFF. You are now in Test mode. Verify the Test mode indicator (red color) on the control box user interface is ON.

Step 5: Press W1 ON on the control box user interface to turn on the first stage of furnace heat. Verify that the furnace fan turns on along with furnace heat.

Step 6: Press W2 ON on the control box user interface to turn on the second stage of furnace heat. Verify that the furnace output increases. This is only applicable for furnaces with two stages. Single-stage furnace shows no difference.

Step 7: Power down the furnace.

Step 8: Set SW01-4 to OFF to disable Test mode.



NOTE

- The PAA unit system enters emergency mode if power is still applied to the furnace and (a)

the outdoor unit loses power or (b) there is an error state that does not allow full system control. The PAA unit remains in emergency mode until power is restored to the outdoor unit or the error is resolved.

- If DIP switch SW01-4 is set to OFF, the NAT connected to the PAA unit control box controls the heat applied to the furnace during an emergency mode failover.

Relay board SW01 DIP switch settings

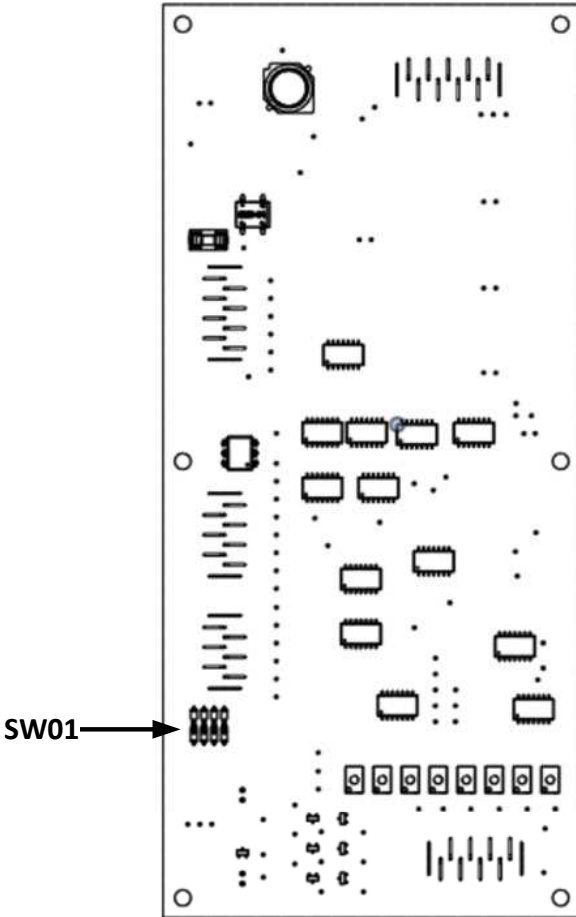

WARNING

If SW01-2 and SW01-4 are set to ON, the furnace will start heating immediately upon a loss of power to the outdoor unit.

Therefore, during gas furnace test operation or maintenance, be sure to power up the outdoor unit prior to powering up the furnace.

Conversely, when powering down the system, the furnace should be powered down prior to powering down the outdoor unit. If operated improperly, it may result in gas leakage/poisoning, fire or explosion due to unexpected gas furnace operation.

SW01-1 Power to non-adjustable thermostat

- ON (default): Power from the furnace is supplied to the TB-B side (14A).
- OFF: Power supply from the furnace to the TB-B side (14A) is not connected.

SW01-2 W1 initial state in Test mode

- ON: W1 is initially switched on when entering Test mode.
- OFF (default): W1 is initially switched off when entering Test mode.

SW01-3 W2 initial state in Test mode

- ON: W2 is initially switched on when entering Test mode.
- OFF (default): W2 is initially switched off when entering Test mode.



NOTE

To enable W2, W1 must be on. Otherwise, W2 will not operate.

SW01-4 Mode operation

- ON: Test mode operation, which is controlled by push buttons on the PAA unit control box user interface.
- OFF (default): Emergency mode operation, which is controlled by the NAT.

Control box user interface

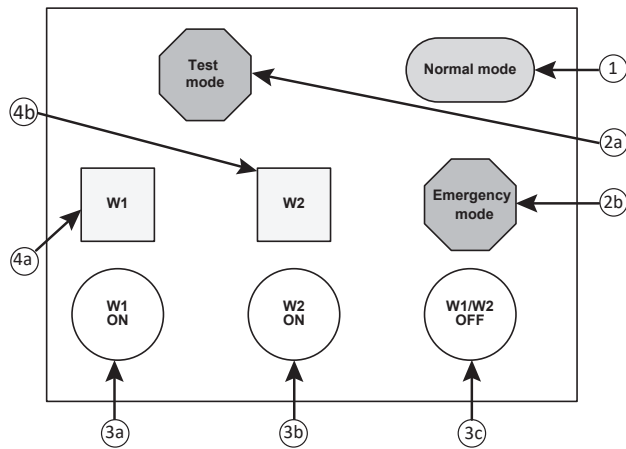

1. Normal mode (indicator color: green). When illuminated, it means that the system is functioning normally.
- 2a. Test mode (indicator color: red) - installer only setting.
- 2b. Emergency mode (indicator color: red). If illuminated, it means that the system is in error mode. If required, please contact a dealer, contractor or technician with certifications required by laws and codes.
- 3a. W1 ON - installer only settings.
Test mode push button (not illuminated, button color: white)
- 3b. W2 ON - installer only settings.
Test mode push button (not illuminated, button color: white)
- 3c. W1 and W2 OFF - installer only settings.
Test mode push button (not illuminated, button color: white)

- 4a. First stage heat (emergency mode) (indicator color: amber) - installer only settings.
- 4b. Second stage heat (emergency mode) (indicator color: amber) - installer only settings.

IMPORTANT

Be sure to change back to Normal mode operation after Test mode operational checks are completed!

NOTE

- The Test and the Emergency modes cannot occur at the same time.
- To enable W2, W1 must be ON.

The non-adjustable thermostat (NAT), a construction-style thermostat included in the accessories bag, should be used as the emergency thermostat.

Install the NAT in the return air duct next to the TH1 thermistor and connect the NAT between R and W1 on the control box. To enable both W1 and W2 to come on when the emergency thermostat calls for heat, connect the W1 and W2 together to one side of the NAT and R to its other side.

| Indoor Unit Settings | | | Outdoor Unit (Extended outdoor air temperature) (see Extended Balance Point section below) |
|----------------------|---------|---------------------------|--|
| Mode 8 | Mode 10 | Balance point | |
| 1 | 1 | 9° F (-13° C) | -11° F (-24° C) |
| 1 | 2 | 14° F (-10° C) | 9° F (-13° C) |
| 2 | 1 | Furnace Only | Furnace Only |
| 2 | 2 | 19° F (-7° C) | 14° F (-10° C) |
| 3 | 1 | 27° F (-3° C) | 27° F (-3° C) |
| 3 | 2 | 32° F (0° C) (default) | 32° F (0° C) (default) |



NOTE

When the PAA unit is connected to a cooling-only unit, configure Mode 8 and Mode 10 for Furnace Only heating.

Below the Economic Balance Point, only the furnace is used for heating. Above the Economic Balance Point, either the heat pump or furnace is used for heating.

In cold climates where the PAA unit may be sized for the cooling load rather than the heating load, the system may not have the capacity to heat the space even at temperatures above the Economic Balance Point.

15.8.2. Capacity balance point

When the PAA unit is first used and the outdoor air temperature is above the Economic Balance Point, the kit first tries to heat the space with the heat pump.

If the kit is unable to heat the space (most likely due to insufficient heating capacity at the current outdoor temperature), the unit records the current outdoor temperature as the Capacity Balance Point and switches to heating with the furnace.

During subsequent calls for heat, if the outdoor temperature is below either the Capacity Balance Point or the Economic Balance Point, then only the furnace is used for heating. If the outdoor air temperature is above both the Capacity Balance Point and

Economic Balance Point, then the heat pump tries to heat the space first.

Capacity Balance Point is incrementally reduced, periodically, until equal to the Economic Balance Point value.

If Mode 25 = 2 and Mode 27 = 2 (which are the recommended initial settings), the PAA unit turns the fan off in Thermo OFF.

15.8.3. Extended balance point

Some outdoor units may have the capacity to report lower outdoor temperatures, below 5° F (-15° C). For information about the outdoor unit's Extended Balance Point capability, refer to the respective outdoor unit manual. The PAA (indoor) unit firmware automatically detects whether the connected outdoor unit has this capability and adjusts the Economic Balance Point accordingly (* see "Outdoor Unit-Extended outdoor air temperature" in the table in the "Economic balance point" section above).

15.9. Condensate overflow safety switch connection (CN4F)

The PAA unit is equipped with a drain pan overflow detection switch and a wire harness for the CN4F connector. The wire harness and switch must be installed before operating the unit. Otherwise the unit will give out an error and cool mode will not run. The normally closed float switch connects to the wires coming from CN4F. When the switch is open, the unit gives out an error and Cool or Dry mode do not run. See diagram below.

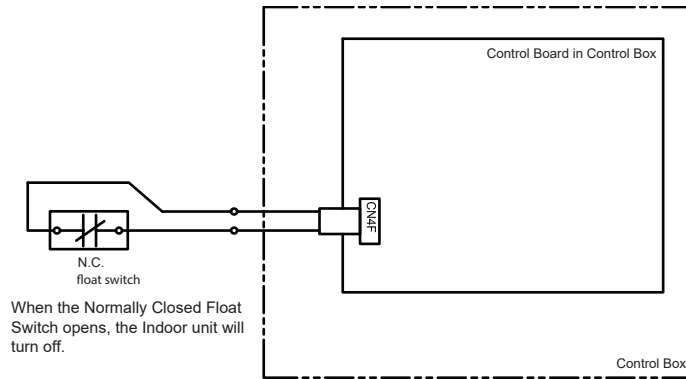

Frequently, a condensate pump is used to pump the condensate from the PAA unit to a drain installed at a higher elevation than the PAA unit. Many condensate pumps have an overflow switch that detects if the reservoir is about to overflow for any reason.

Typically, these overflow switches are also normally closed switches that should be wired in series with the drain pan overflow switch as in the illustration above.

15.10. Energy recovery ventilation (ERV)

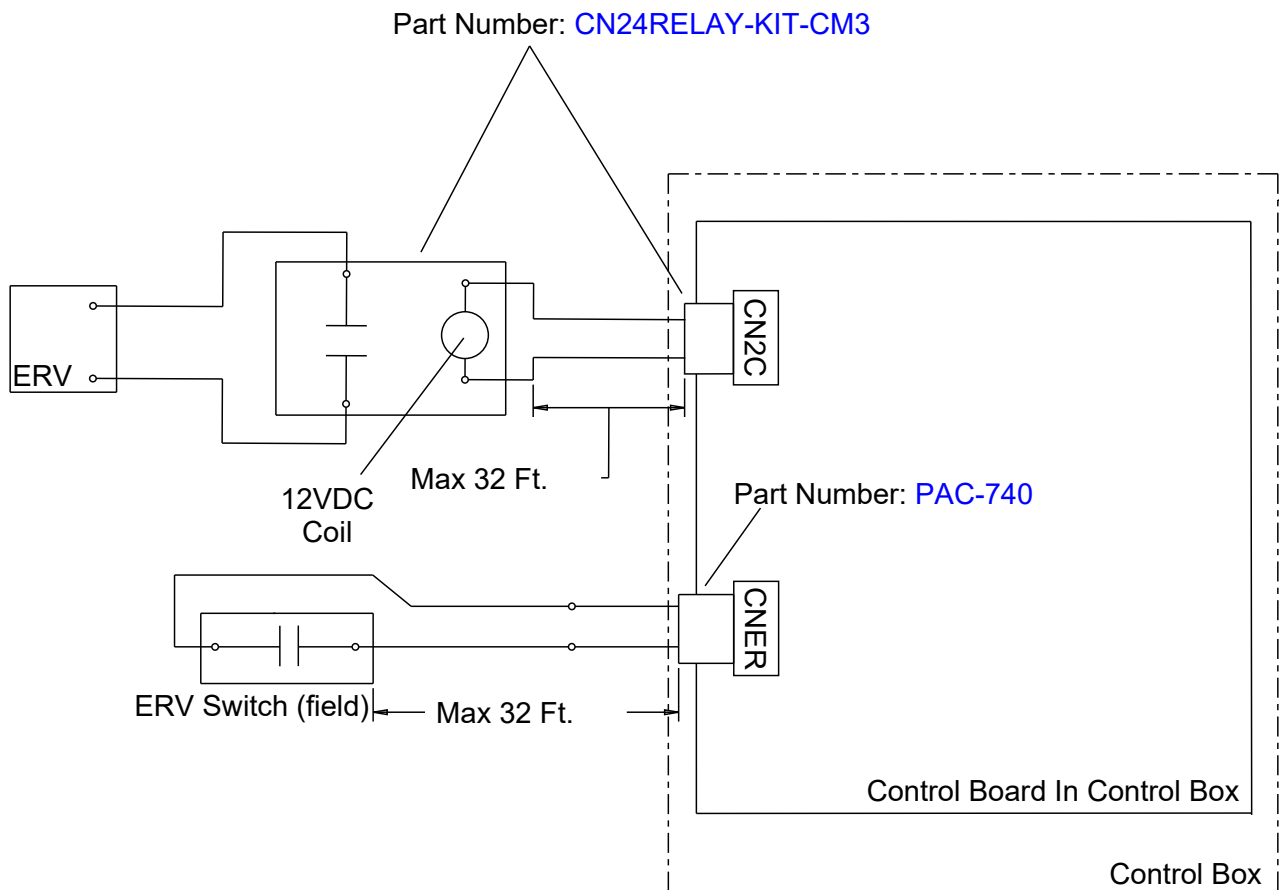

ERV Switch

- Non-Voltage a-contact input
- Contact rating current ≥ 0.1 A
- Contact rating voltage ≥ 15 VDC
- Minimum applicable load ≤ 1 mA at DC

| ERV output | Condition | Furnace blower (expected operation) | CN2C output (expected furnace blower output) |
|-------------------|-------------------------|--|--|
| CNER input | | | |
| OFF | Cool/Heat/Fan operation | ON ^{1,2} | ON |
| | Defrost | STOP | OFF |
| | STOP | STOP | OFF |
| ON | Cool/Heat/Fan operation | ON ¹ | ON |
| | Defrost | STOP | OFF |
| | STOP | ON ¹ | ON |

¹The G/Y1 signal to the furnace is energized to turn on the furnace blower. If kumo cloud[®] app is used and configured to operate a second stage blower speed, the Y/Y2 signal is also energized.

²It is recommended to set Modes 25 and 27 to 2, in order to have the indoor fan stop running when set temperature is met. Otherwise, CN2C will energize the ERV 24/7.

15.10.1. HRV/ERV heating operation for MXZ/NTXM systems

When using an HRV/ERV, please take appropriate consideration when operating it during heating.

| Model | Description |
|------------------------------------|--|
| MXZ-3C24/3C30/4C36/5C42NA3/4 | When the furnace blower is moving air for HRV/ERV operation, the unit may provide warm air to the occupied space, even in Thermo OFF mode. |
| MXZ-3C24/3C30NAHZ3/4 | |
| NTXMMX24/30/36/42A132/142/152BA/CA | |
| NTXMPH24/30A132BA/CA | |
| MXZ-SM36/42/60NAM/2 | |
| MXZ-SM36/42/48NAMHZ/2 | |
| NTXMSM36/48/60A142/182AA/BA | |
| NTXMSH36/42/48A142/152/182AA/BA | |

15.11. Humidifier

Part Number: [CN24RELAY-KIT-CM3](#)

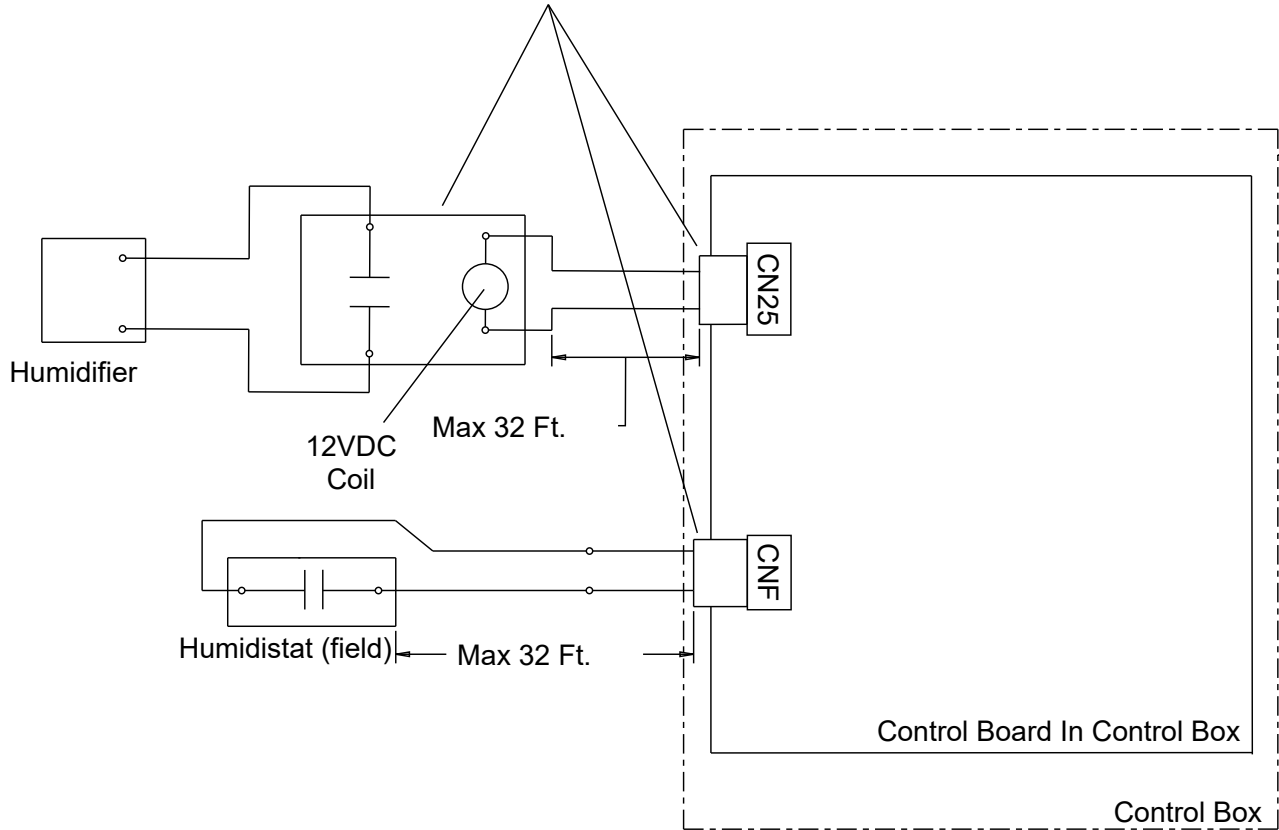

Humidifier Control

Sequence of operation:

1. The humidistat closes CNF.
2. The furnace blower turns on.
3. CN25 provides 12 VDC to turn on the humidifier (do not exceed 1 watt draw per relay).
4. When the humidistat opens CNF, the furnace blower continues to run for 30 seconds to clear the ductwork of moist air.

5. If defrost starts during humidifier operation, CN25 de-energizes.

Humidistat:

- Non-voltage a-contact input
- Contact rating voltage ≥ 15 VDC
- Contact Rating Current ≥ 0.1 A
- Minimum Applicable Load ≤ 1 mA at DC

| Mode no. | Setting no. | Settings |
|---|-------------|--------------------------|
| 13 | 1 | Humidifier not supported |
| | 2 | Humidifier supported |
| 16 (applies if Mode no. 13 Setting no. = 2) | 1 | See Mode 16 table below. |
| | 2 | See Mode 16 table below. |

| Mode no. 16 | CNF Input (humidistat) | Condition (No Defrost/No Error) | CN25 Output | Furnace Blower |
|--|---------------------------|------------------------------------|-------------|-------------------|
| 1 ¹ | OFF | Heat mode & Ther- mo OFF | OFF | OFF ² |
| | | Heat mode & Ther- mo ON | | |
| | ON | Heat mode & Ther- mo OFF | OFF | OFF ² |
| | | Heat mode & Ther- mo ON | ON | ON ² |
| 2 | OFF | Heat mode & Ther- mo OFF | OFF | OFF ² |
| | | Heat mode & Ther- mo ON | | |
| | ON | Heat mode & Ther- mo OFF | ON | ON ² |
| | | Heat mode & Ther- mo ON | | |
| ¹ Factory setting ² The G/Y1 signal to the furnace is energized to turn on the furnace blower. If kumo cloud [®] app is used and configured to operate a second stage blower speed, the Y/Y2 signal is also energized. | | | | |



NOTE

- Humidifier output will only run when in heating mode.

- In heating mode, if homeowner prefers that the fan runs even while thermal set point is satiated, set Mode 25 to 1. For the same in cooling mode, set Mode 27 to 1.

16. Test run

16.1. Before test run

After completing installation and the wiring and piping of the indoor and outdoor units, check for refrigerant leakage, looseness in the power supply or control wiring, wrong polarity, and no disconnection of one phase in the supply. Use a 500-volt megohmmeter to check that the resistance between the power supply terminals and ground is at least 1.0 MΩ.

Do not carry out this test on the control wiring (low voltage circuit) terminals.



WARNING

If SW01-2 and SW01-4 are set to ON, the furnace will start heating immediately upon a loss of power to the outdoor unit. Therefore, during gas furnace test operation or maintenance, be sure to power up the outdoor unit prior to powering up the furnace. Conversely, when powering down

the system, the furnace should be powered down prior to powering down the outdoor unit. If operated improperly, it may result in gas leakage/poisoning, fire or explosion due to unexpected gas furnace operation.

! WARNING

Do not use the air conditioner if the insulation resistance is less than 1.0 MΩ. Otherwise, results such as electric shock, fire or explosion may occur.

Open the stop valves isolating the PAA unit from the outdoor unit before starting operation to avoid refrigerant pipe bursting during furnace operation.

After installation or after the power source to the unit has been cut for an extended period, the insulation resistance will drop below 1 MΩ due to refrigerant accumulating in the compressor. This is not a malfunction. Perform the following procedures.

1. Remove the wires from the compressor and measure the insulation resistance of the compressor.
2. If the insulation resistance is below 1 MΩ, the compressor is faulty or the resistance dropped due the accumulation of refrigerant in the compressor.
3. After connecting the wires to the compressor, the compressor will start to warm up after power is supplied. After supplying power for the times indicated below, measure the insulation resistance again.
 - The insulation resistance drops due to accumulation of refrigerant in the compressor. The resistance will rise above 1 MΩ after the compressor is warmed up for two to three hours. (The time necessary to warm up the compressor varies according to atmospheric conditions and refrigerant accumulation.)
 - To operate the compressor with refrigerant accumulated in the compressor, the compressor must be warmed up at least 12 hours to prevent breakdown.
4. If the insulation resistance rises above 1 MΩ, the compressor is not faulty.

! CAUTION

- The compressor will not operate unless the power supply phase connection is correct.
- Turn on the power at least 12 hours before starting operation. – Starting operation immediately after turning on the main power switch can result in severe damage to internal parts. Keep the power switch turned on during the operational season.

16.2. Perform test run

Refer to the installation manual that comes with each remote controller for details.

16.3. Complete self check

Refer to the installation manual that comes with each remote controller for details. IR and RF controller not supported.

| [Output pattern A] Errors detected by indoor unit | | |
|---|------------|--|
| Wired remote controller Check code | | Symptom |
| P1 | 5101 | Intake sensor error |
| P2, P9 | 5102, 5105 | Pipe (liquid or gas pipe) sensor error |
| E6, E7 | 6840 | Indoor/outdoor unit communication error |
| P4 | 2502 | Drain sensor error |
| P5 | 5701 | Drain pump error |
| P6 | 1501 | Freezing/Overheating safeguard operation |
| EE | - | Communication error between indoor and outdoor units |
| P8 | 1503 | Pipe temperature error |
| E4 | 6834 | MA remote controller signal receiving error |

| [Output pattern A] Errors detected by indoor unit | | |
|--|------|---|
| Wired remote controller Check code | | Symptom |
| Fb | 4109 | Indoor unit control system error (memory error, etc.) |

- On wired MA remote controller, check code displayed on the LCD.
- If the unit cannot be operated properly after the above test run has been performed, refer to the troubleshooting section of the ODU service manual for assistance.



NOTE

Operation is not possible for about 30 seconds after cancellation of function selection. (Correct operation)

| [Output pattern B] Errors detected by unit other than indoor unit (outdoor unit, etc.) | |
|---|--|
| Check code | Symptom |
| E9 | Indoor/outdoor unit communication error (Transmitting error) (Outdoor unit) |
| UP | Compressor overcurrent interruption |
| U3, U4 | Open/short of outdoor unit thermistors |
| UF | Compressor overcurrent interruption (when compressor locked) |
| U2 | Abnormal high discharging temperature/49C worked/ Insufficient refrigerant |
| U1, Ud | Abnormal high pressure (63H worked)/Overheating safeguard operation |
| U5 | Abnormal temperature of heat sink |
| U8 | Outdoor unit fan protection stop |
| U6 | Compressor overcurrent interruption/Abnormal of power module |
| U7 | Abnormality of super heat due to low discharge temperature |
| U9, UH | Abnormality such as overvoltage or voltage shortage and abnormal and synchronous signal to main circuit/Current sensor error |
| others | Other errors (Refer to the outdoor unit service manual.) |

For description of each LED (LED1, 2, 3) provided on the control board, refer to the following table.

| | |
|--|---|
| LED 1 (power for microcomputer) | Indicates whether control power is supplied. Make sure that this LED is always lit. |
| LED 2 (power for remote controller) | Indicates whether power is supplied to the remote controller. This LED lights only in the case of the indoor unit which is connected to the outdoor unit refrigerant address "0". |
| LED 3 (communication between indoor and outdoor units) | Indicates state of communication between the indoor and outdoor units. Make sure that this LED is always blinking. |

16.4. Auto restart function

Indoor controller board

This model is equipped with the AUTO RESTART FUNCTION. When the indoor unit is controlled with the remote controller, the operation mode, set temperature and the fan speed are memorized by the indoor controller board.

The auto restart function works after power is restored after a power failure. The unit will restart automatically approximately 4 minutes after power is restored. Auto restart function is regulated using the remote controller (Mode no. 01).

17. Cut out gauge

Refer to section "Float switch", step 3 for use instructions.

CUT OUT GAUGE TEMPLATE

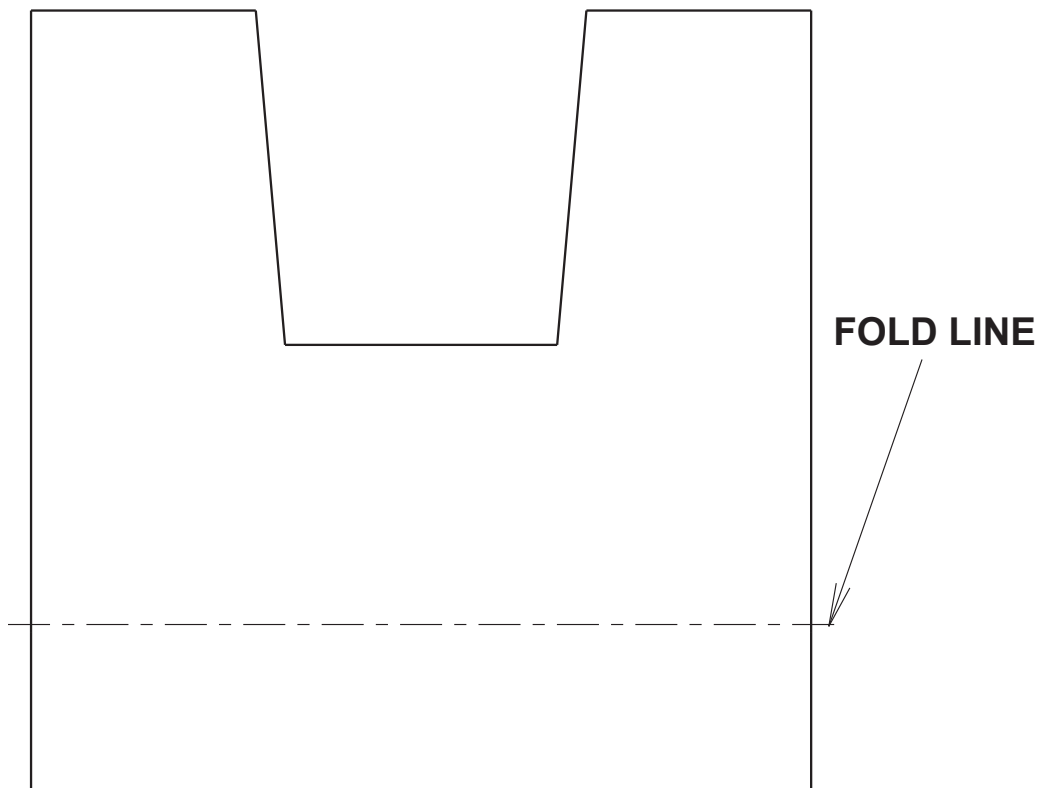

100% SCALE MODEL

This product is designed and intended for use in the residential and commercial environment.

Manufactured by:
MITSUBISHI ELECTRIC US, INC.



Toll Free: 800-433-4822