

SPLIT-TYPE AIR CONDITIONERS

# OUTDOOR UNIT

**Revision B:**

- MUZ-WR09/12/18NA-U2 have been added.
- 10-4. The resistant value of the defrost heater has been corrected.

OBH819 REVISED EDITION-A is void.

# SERVICE MANUAL



No. OBH819  
REVISED EDITION-B

## Models

**MUZ-WR09NA** - U1 , U2

**MUZ-WR12NA** - U1 , U2

**MUZ-WR18NA** - U1 , U2

**MUZ-WR24NA** - U1

Indoor unit service manual  
MSZ-WR•NA Series (OBH818)

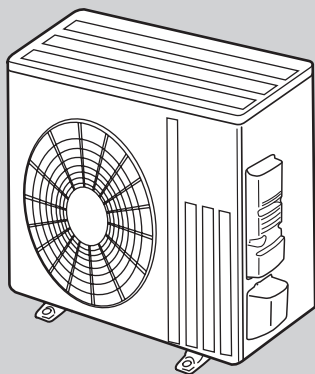

MUZ-WR24NA

## CONTENTS

1. TECHNICAL CHANGES .....	2
2. PART NAMES AND FUNCTIONS .....	3
3. SPECIFICATION .....	4
4. OUTLINES AND DIMENSIONS .....	7
5. WIRING DIAGRAM .....	9
6. REFRIGERANT SYSTEM DIAGRAM .....	12
7. DATA .....	15
8. ACTUATOR CONTROL .....	25
9. SERVICE FUNCTIONS .....	26
10. TROUBLESHOOTING .....	27
11. DISASSEMBLY INSTRUCTIONS .....	52

**PARTS CATALOG (OBB819)**

## Use the specified refrigerant only

### Never use any refrigerant other than that specified.

Doing so may cause a burst, an explosion, or fire when the unit is being used, serviced, or disposed of.

Correct refrigerant is specified in the manuals and on the spec labels provided with our products.

We will not be held responsible for mechanical failure, system malfunction, unit breakdown or accidents caused by failure to follow the instructions.

### Revision B:

- MUZ-WR09/12/18NA-U2 have been added.

## 1

## TECHNICAL CHANGES

**MUZ-WR09NA - U1**

**MUZ-WR12NA - U1**

**MUZ-WR18NA - U1**

**MUZ-WR24NA - U1**

1. New model

**MUZ-WR09NA - U1 → MUZ-WR09NA - U2**

**MUZ-WR12NA - U1 → MUZ-WR12NA - U2**

1. Fan motor has been changed.
2. Inverter P.C. board has been changed.
3. R.V. coil has been changed.
4. LEV has been changed.
5. Outdoor heat exchanger has been changed.
6. 4-way valve has been changed.
7. Compressor has been changed.

**MUZ-WR18NA - U1 → MUZ-WR18NA - U2**

1. Fan motor has been changed.
2. Inverter P.C. board has been changed.
3. LEV has been changed.

## 2

## PART NAMES AND FUNCTIONS

MUZ-WR09NA MUZ-WR12NA MUZ-WR18NA

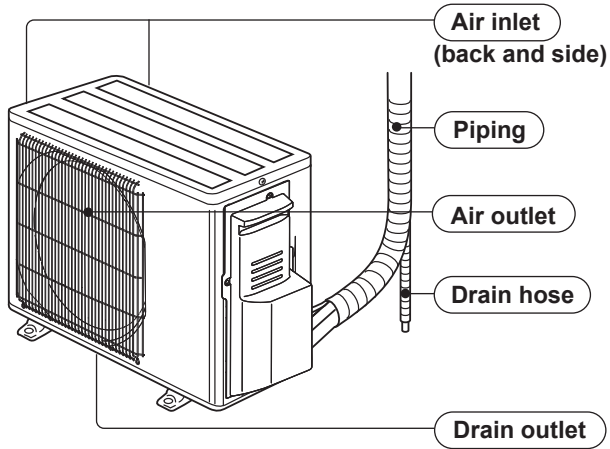

MUZ-WR24NA

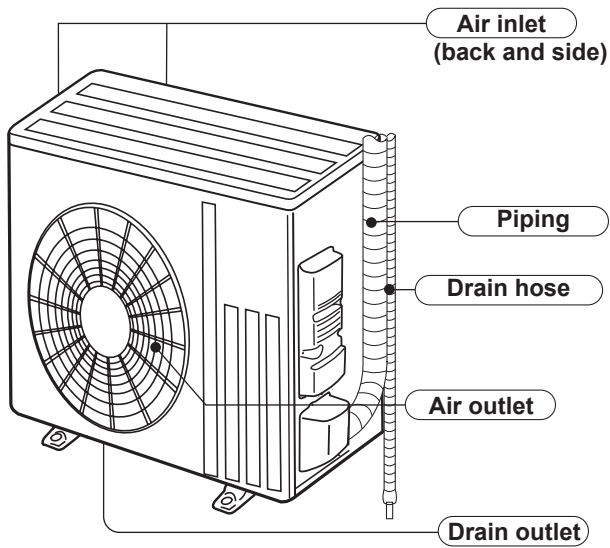

# 3

# SPECIFICATION

Outdoor unit model			MUZ-WR09NA -U1	MUZ-WR09NA -U2	MUZ-WR12NA -U1	MUZ-WR12NA -U2
Capacity Rated (Minimum~Maximum)	Cooling *1	Btu/h	9,000 ( 3,800 - 10,000 )		12,000 ( 3,800 - 12,200 )	
	Heating 47 *1	Btu/h	10,900 ( 4,500 - 11,800 )		12,200 ( 4,500 - 14,500 )	
Capacity Rated (Maximum)	Heating 17 *2	Btu/h	6,700 (7,200)		7,600 (9,000)	
Power consumption Rated (Minimum~Maximum)	Cooling *1	W	820 (240 - 930)		1,330 (240 - 1,400)	
	Heating 47 *1	W	980 (240 - 1,090)		1,090 (240 - 1,340)	
Power consumption Rated (Maximum)	Heating 17 *2	W	760 (850)		880 (1,090)	
EER *1 [SEER] *3	Cooling		11.0 [ 16.0 ]		9.0 [ 16.0 ]	
HSPF IV *4	Heating		8.5			
COP	Heating *1		3.25		3.28	
Power factor	Cooling (208/230)	%	87/87		95/95	
	Heating (208/230)	%	90/90		93/93	
Power supply	V , phase , Hz		208/230 , 1 , 60			
Max. fuse size (time delay)	A		15			
Min. circuit ampacity	A		9			
Fan motor	F.L.A	A	0.50			
Compressor	Model		KNB073FRVMC	KNB073FRXMC	KNB073FRVMC	KNB073FRXMC
	R.L.A	A	6.2			
	L.R.A	A	7.7			
	Refrigeration oil	fl oz. (L) (Model)	9.1 (0.27) (FV50S)			
Refrigerant control			Linear expansion valve			
Sound level *1	Cooling	dB(A)	48		51	
	Heating	dB(A)	50		51	
Airflow High - Med. - Low	Cooling	CFM	1,063 - 1,063 - 1,063			
	Heating	CFM	1,282 - 1,105 - 1,105			
Fan speed High - Med. - Low	Cooling	rpm	740 - 740 - 740			
	Heating	rpm	890 - 770- 770			
Defrost method			Reverse cycle			
Dimensions	W	in.	31-1/2			
	D	in.	11-1/4			
	H	in.	21-5/8			
Weight	lb.		73			
External finish			Munsell 3Y 7.8/1.1			
Refrigerant piping			Not supplied			
Refrigerant pipe size (Min. wall thickness)	Liquid	in.	1/4 (0.0315)			
	Gas	in.	3/8 (0.0315)			
Connection method	Indoor		Flared			
	Outdoor		Flared			
Between the indoor & outdoor units	Height difference	ft.	40			
	Piping length	ft.	65			
Refrigerant charge (R410A)			1 lb. 12 oz.			

**NOTE:** Test conditions are based on AHRI 210/240.

\*1: Rating conditions (Cooling) — Indoor: 80°FDB, 67°FWB, Outdoor: 95°FDB, (75°FWB)

(Heating) — Indoor: 70°FDB, 60°FWB, Outdoor: 47°FDB, 43°FWB

\*2: (Heating) — Indoor: 70°FDB, 60°FWB, Outdoor: 17°FDB, 15°FWB

\*3: Test condition (Refer to 3-1.)

\*4: Test condition (Refer to 3-1.)



Outdoor unit model			MUZ-WR18NA	MUZ-WR24NA
Capacity Rated (Minimum~Maximum)	Cooling *1	Btu/h	17,200 (5,800 - 18,000)	22,500 (5,800 - 22,500)
	Heating 47 *1	Btu/h	18,000 (5,400 - 20,900)	26,000 (5,400 - 26,000)
Capacity Rated (Maximum)	Heating 17 *2	Btu/h	11,500 (15,000)	18,500 (18,500)
Power consumption Rated (Minimum~Maximum)	Cooling *1	W	1,720 (350 - 2,170)	2,810 (330 - 2,810)
	Heating 47 *1	W	1,670 (330 - 2,360)	2,680 (320 - 2,680)
Power consumption Rated (Maximum)	Heating 17 *2	W	1,360 (2,040)	2,460 (2,460)
EER *1 [SEER] *3	Cooling		10.0 [16.0]	8.0 [16.0]
HSPF IV *4	Heating		8.5	8.5
COP	Heating *1		3.16	2.84
Power factor	Cooling (208/230)	%	98/98	99/99
	Heating (208/230)	%	97/97	99/99
Power supply	V , phase , Hz		208/230, 1, 60	
Max. fuse size (time delay)	A		15	
Min. circuit ampacity	A		10	14
Fan motor	F.L.A	A	0.50	0.93
Compressor	Model		SNB130FQBMT	
	R.L.A	A	7.4	10
	L.R.A	A	9.3	12.5
	Refrigeration oil	fl oz. (L) (Model)	11.8 (0.35) (FV50S)	
Refrigerant control	Linear expansion valve			
Sound level *1	Cooling	dB(A)	53	57
	Heating	dB(A)	51	55
Airflow High - Med. - Low	Cooling	CFM	1,102 - 1,102 - 639	1,742 - 1,742 - 922
	Heating	CFM	1,186 - 1,045 - 1,045	1,691 - 1,691 - 1,372
Fan speed High - Med. - Low	Cooling	rpm	810 - 810 - 490	840 - 840 - 450
	Heating	rpm	870 - 770 - 770	810 - 810 - 650
Defrost method	Reverse cycle			
Dimensions	W	in.	31-1/2	33-1/16
	D	in.	11-1/4	13
	H	in.	21-5/8	34-5/8
Weight	lb.		81	121
External finish			Munsell 3Y 7.8/1.1	Munsell 3Y 7.8/1.1
Refrigerant piping			Not supplied	Not supplied
Refrigerant pipe size (Min. wall thickness)	Liquid	in.	1/4 (0.0315)	3/8 (0.0315)
	Gas	in.	1/2 (0.0315)	5/8 (0.0315)
Connection method	Indoor		Flared	
	Outdoor		Flared	
Between the indoor & outdoor units	Height difference	ft.	40	50
	Piping length	ft.	65	100
Refrigerant charge (R410A)			2 lb. 10 oz.	3 lb. 9 oz.

**NOTE:** Test conditions are based on AHRI 210/240.

\*1: Rating conditions (Cooling) — Indoor: 80°FDB, 67°FWB, Outdoor: 95°FDB, (75°FWB)  
(Heating) — Indoor: 70°FDB, 60°FWB, Outdoor: 47°FDB, 43°FWB

\*2: (Heating) — Indoor: 70°FDB, 60°FWB, Outdoor: 17°FDB, 15°FWB

\*3: Test condition (Refer to 3-1.)

\*4: Test condition (Refer to 3-1.)

### 3-1. TEST CONDITION

※3,※4

ARI	Mode	Test	Indoor air condition (°F)		Outdoor air condition (°F)	
			Dry bulb	Wet bulb	Dry bulb	Wet bulb
	SEER (Cooling)	"A-2" Cooling steady state at rated compressor speed	80	67	95	(75)
		"B-2" Cooling steady state at rated compressor speed	80	67	82	(65)
		"B-1" Cooling steady state at minimum compressor speed	80	67	82	(65)
		"F-1" Cooling steady state at minimum compressor speed	80	67	67	(53.5)
		"E-V" Cooling steady state at intermediate compressor speed ※5	80	67	87	(69)
	HSPF (Heating)	"H1-2" Heating steady state at rated compressor speed	70	60	47	43
		"H3-2" Heating at rated compressor speed	70	60	17	15
		"H0-1" Heating steady state at minimum compressor speed	70	60	62	56.5
		"H1-1" Heating steady state at minimum compressor speed	70	60	47	43
		"H2-V" Heating at intermediate compressor speed ※5	70	60	35	33

※5: At intermediate compressor speed  
 = ("Rated compressor speed" - "minimum compressor speed") / 3 + "minimum compressor speed".

### 3-2. OPERATING RANGE

#### (1) POWER SUPPLY

	Rated voltage	Guaranteed voltage (V)
Outdoor unit	208/230 V 1 phase 60 Hz	

#### (2) OPERATION

Mode	Condition	Intake air temperature (°F)			
		Indoor		Outdoor	
		DB	WB	DB	WB
Cooling	Standard temperature	80	67	95	—
	Maximum temperature	90	73	115	—
	Minimum temperature	67	57	32	—
	Maximum humidity	78 %		—	
Heating	Standard temperature	70	60	47	43
	Maximum temperature	80	67	75	65
	Minimum temperature	70	60	5	4

# 4

# OUTLINES AND DIMENSIONS

MUZ-WR09NA MUZ-WR12NA MUZ-WR18NA

Unit: inch

## REQUIRED SPACE

\*1 4 in. (100 mm) or more when front and sides of the unit are clear

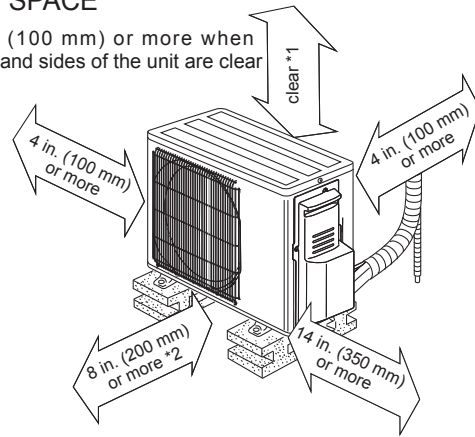

\*2 When any 2 sides of left, right and rear of the unit are clear

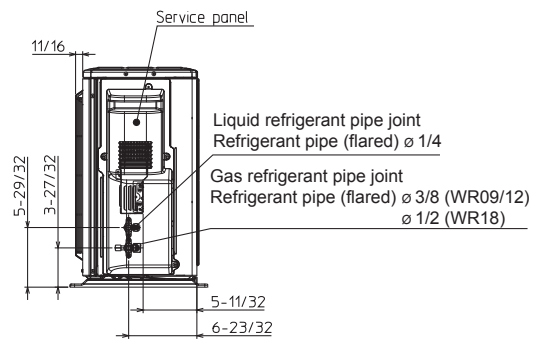
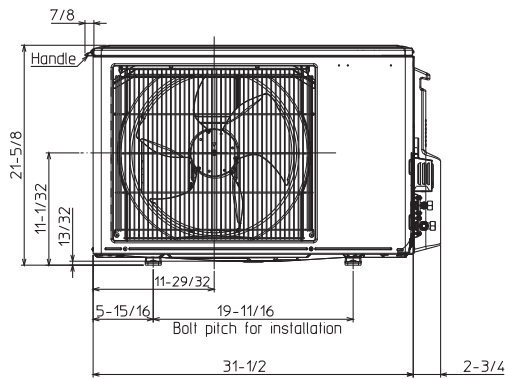
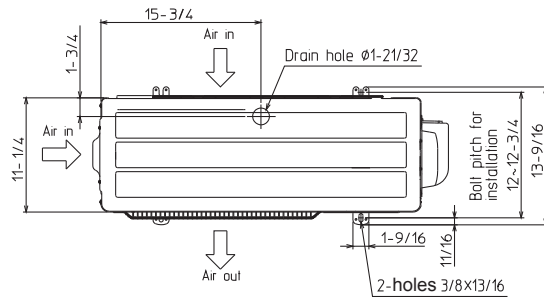

**MUZ-WR24NA**

**Unit: inch**

**REQUIRED SPACE**

\*1 20 in. (500 mm) or more when front and sides of the unit are clear

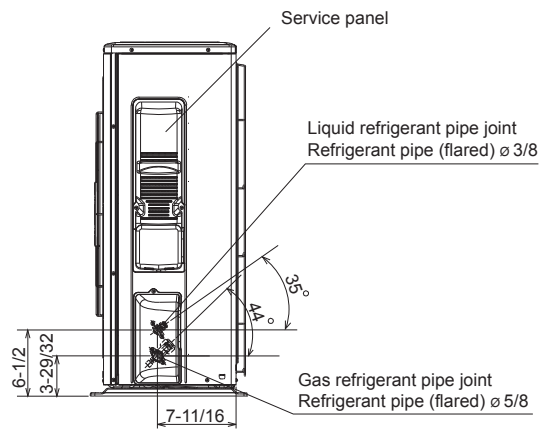
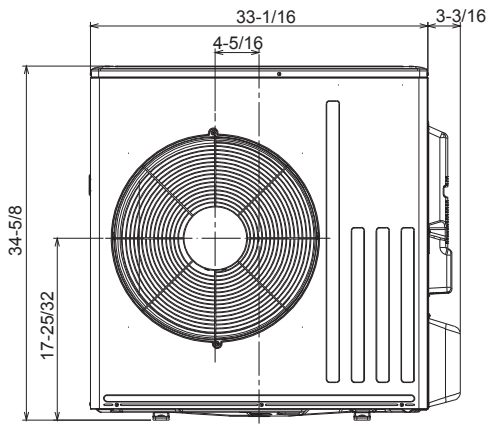
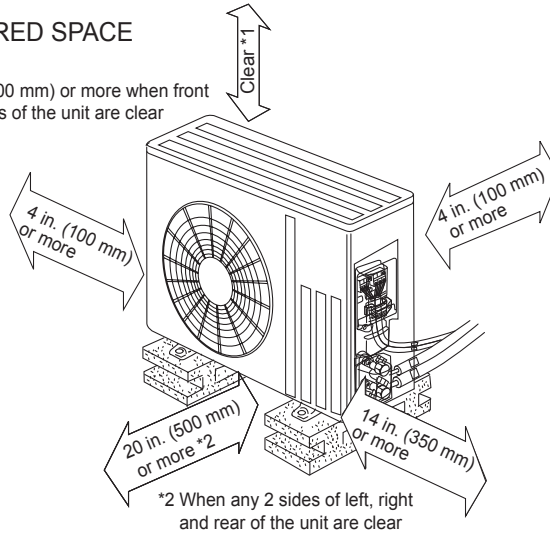
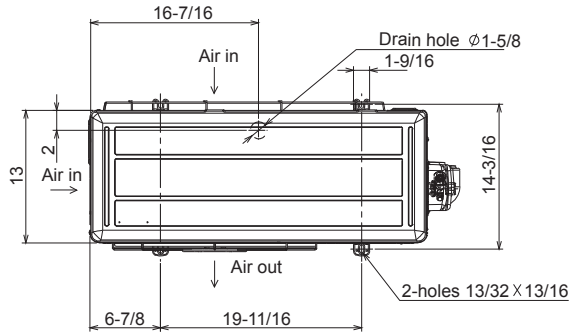

# 5

# WIRING DIAGRAM

## MUZ-WR09NA-U1 MUZ-WR12NA-U1

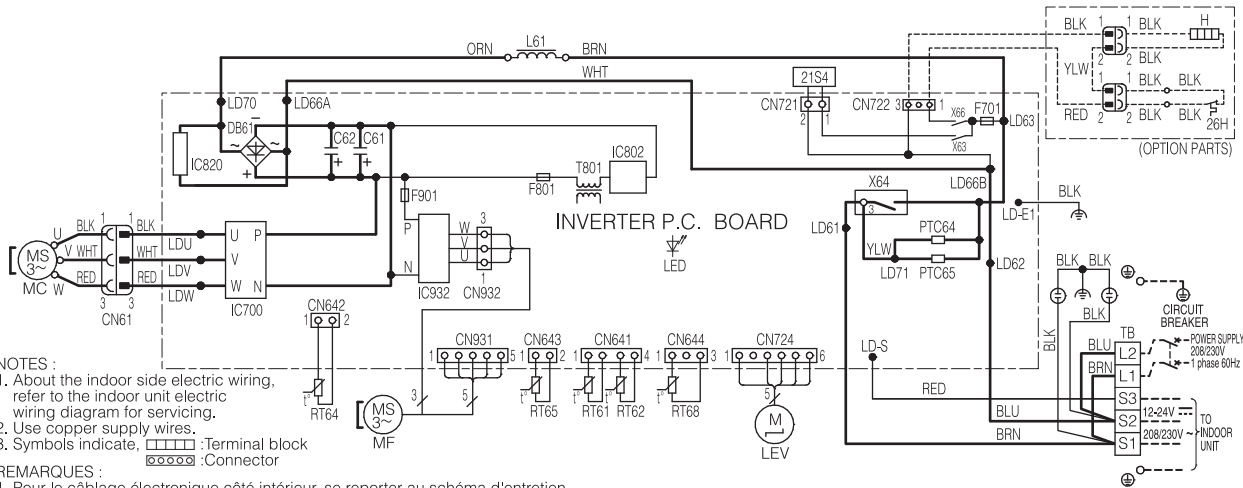

**NOTES :**

1. About the indoor side electric wiring, refer to the indoor unit electric wiring diagram for servicing.
2. Use copper supply wires.
3. Symbols indicate, :Terminal block :Connector

**REMARQUES :**

1. Pour le câblage électronique côté intérieur, se reporter au schéma d'entretien du câblage électronique de l'appareil intérieur.
2. Utiliser des fils d'alimentation en cuivre.
3. Les symboles ont les significations suivantes, :Borne :Connecteur

SYMBOL	NAME	SYMBOL	NAME	SYMBOL	NAME
CN61	CONNECTOR	LEV	EXPANSION VALVE COIL	RT65	AMBIENT TEMP. THERMISTOR
C61,C62	SMOOTHING CAPACITOR	L61	REACTOR	RT68	OUTDOOR HEAT EXCHANGER TEMP. THERMISTOR
DB61	DIODE MODULE	MC	COMPRESSOR	TB	TERMINAL BLOCK
F701,F801,F901	FUSE (T3, 15AL250V)	MF	FAN MOTOR	T801	TRANSFORMER
IC700,IC820,IC932	POWER MODULE	PTC64, PTC65	CIRCUIT PROTECTION	X63, X64, X66	RELAY
IC802	POWER DEVICE	RT61	DEFROST THERMISTOR	21S4	REVERSING VALVE COIL
LED	LED	RT62	DISCHARGE TEMP. THERMISTOR	26H	HEATER PROTECTOR(OPTION PARTS)
		RT64	FIN TEMP. THERMISTOR		

## MUZ-WR09NA-U2 MUZ-WR12NA-U2

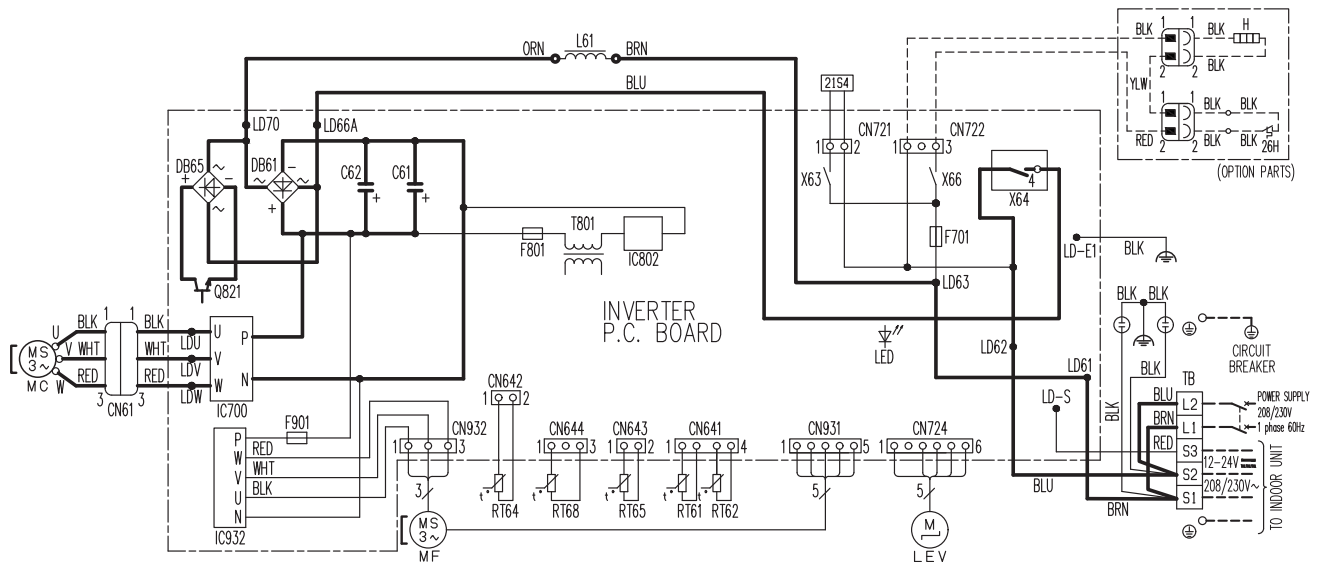

**NOTES :**

1. About the indoor side electric wiring, refer to the indoor unit electric wiring diagram for servicing.
2. Use copper supply wires.
3. Symbols indicate, :Terminal block :Connector

**REMARQUES :**

1. Pour le câblage électronique côté intérieur, se reporter au schéma d'entretien du câblage électronique de l'appareil intérieur.
2. Utiliser des fils d'alimentation en cuivre.
3. Les symboles ont les significations suivantes, :Borne :Connecteur

SYMBOL	NAME	SYMBOL	NAME	SYMBOL	NAME
CN61	CONNECTOR	LEV	EXPANSION VALVE COIL	RT65	AMBIENT TEMP. THERMISTOR
C61,C62	SMOOTHING CAPACITOR	L61	REACTOR	RT68	OUTDOOR HEAT EXCHANGER TEMP. THERMISTOR
DB61,DB65	DIODE MODULE	MC	COMPRESSOR	TB	TERMINAL BLOCK
F701,F801,F901	FUSE (T3, 15AL250V)	MF	FAN MOTOR	T801	TRANSFORMER
H	DEFROST HEATER (OPTION PARTS)	Q821	SWITCHING POWER TRANSISTOR	X63, X64, X66	RELAY
IC700,IC932	POWER MODULE	RT61	DEFROST THERMISTOR	21S4	REVERSING VALVE COIL
IC802	POWER DEVICE	RT62	DISCHARGE TEMP. THERMISTOR	26H	HEATER PROTECTOR(OPTION PARTS)
LED	LED	RT64	FIN TEMP. THERMISTOR		

# MUZ-WR18NA-U1

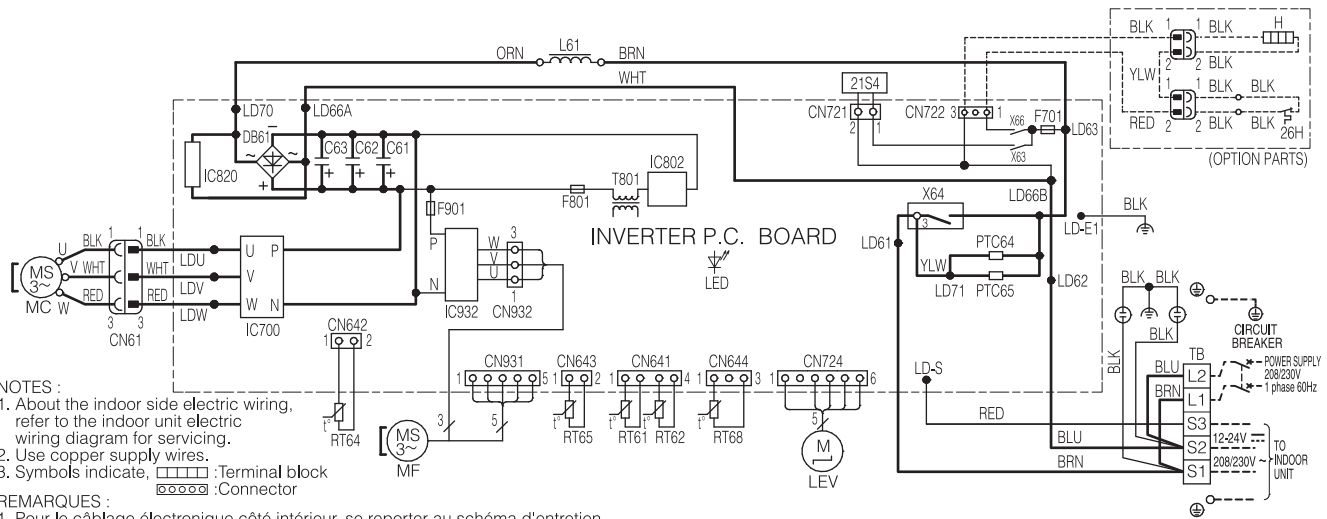

- NOTES :**
- About the indoor side electric wiring, refer to the indoor unit electric wiring diagram for servicing.
  - Use copper supply wires.
  - Symbols indicate, :Terminal block :Connector
- REMARQUES :**
- Pour le câblage électronique côté intérieur, se reporter au schéma d'entretien du câblage électronique de l'appareil intérieur.
  - Utiliser des fils d'alimentation en cuivre.
  - Les symboles ont les significations suivantes, :Borne :Connecteur

SYMBOL	NAME	SYMBOL	NAME	SYMBOL	NAME
CN61	CONNECTOR	LEV	EXPANSION VALVE COIL	RT65	AMBIENT TEMP. THERMISTOR
C61,C62,C63	SMOOTHING CAPACITOR	L61	REACTOR	RT68	OUTDOOR HEAT EXCHANGER TEMP. THERMISTOR
DB61	DIODE MODULE	MC	COMPRESSOR	TB	TERMINAL BLOCK
F701,F801,F901	FUSE (T3, 15A/250V)	MF	FAN MOTOR	T801	TRANSFORMER
H	DEFROST HEATER(OPTION PARTS)	PTC64, PTC65	CIRCUIT PROTECTION	X63, X64, X66	RELAY
IC700,IC820,IC932	POWER MODULE	RT61	DEFROST THERMISTOR	21S4	REVERSING VALVE COIL
IC802	POWER DEVICE	RT62	DISCHARGE TEMP. THERMISTOR	26H	HEATER PROTECTOR(OPTION PARTS)
LED	LED	RT64	FIN TEMP. THERMISTOR		

# MUZ-WR18NA-U2

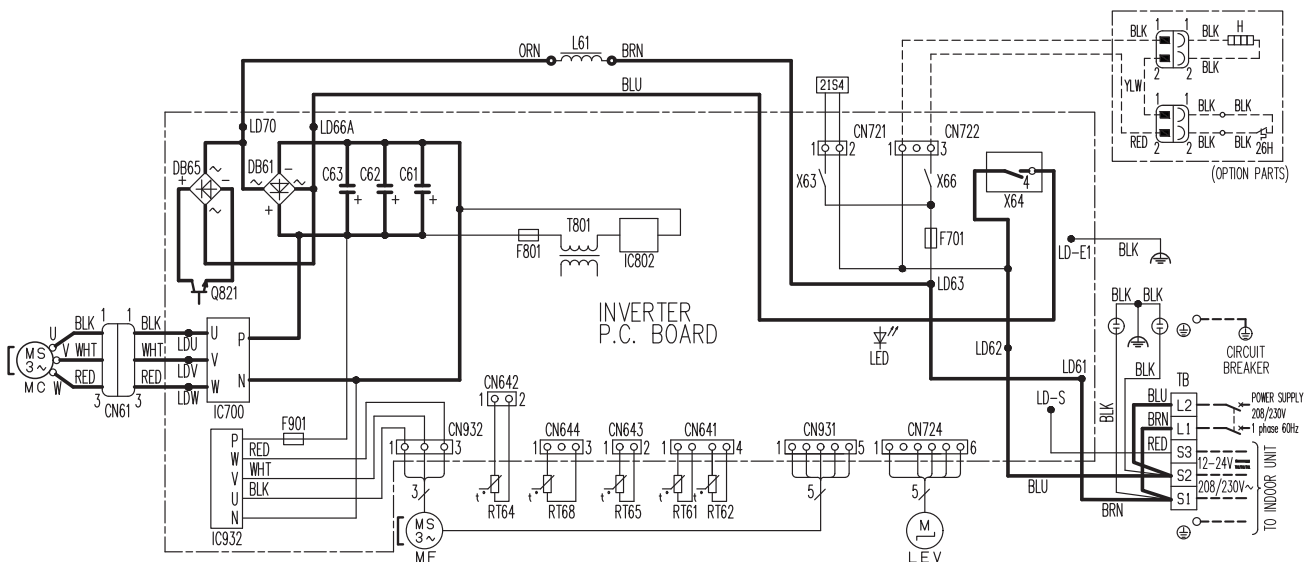

- NOTES :**
- About the indoor side electric wiring, refer to the indoor unit electric wiring diagram for servicing.
  - Use copper supply wires.
  - Symbols indicate, :Terminal block :Connector
- REMARQUES :**
- Pour le câblage électronique côté intérieur, se reporter au schéma d'entretien du câblage électronique de l'appareil intérieur.
  - Utiliser des fils d'alimentation en cuivre.
  - Les symboles ont les significations suivantes, :Borne :Connecteur

SYMBOL	NAME	SYMBOL	NAME	SYMBOL	NAME
CN61	CONNECTOR	LEV	EXPANSION VALVE COIL	RT65	AMBIENT TEMP. THERMISTOR
C61,C62,C63	SMOOTHING CAPACITOR	L61	REACTOR	RT68	OUTDOOR HEAT EXCHANGER TEMP. THERMISTOR
DB61, DB65	DIODE MODULE	MC	COMPRESSOR	TB	TERMINAL BLOCK
F701,F801,F901	FUSE (T3, 15A/250V)	MF	FAN MOTOR	T801	TRANSFORMER
H	DEFROST HEATER(OPTION PARTS)	Q821	SWITCHING POWER TRANSISTOR	X63, X64, X66	RELAY
IC700,IC932	POWER MODULE	RT61	DEFROST THERMISTOR	21S4	REVERSING VALVE COIL
IC802	POWER DEVICE	RT62	DISCHARGE TEMP. THERMISTOR	26H	HEATER PROTECTOR(OPTION PARTS)
LED	LED	RT64	FIN TEMP. THERMISTOR		

# MUZ-WR24NA

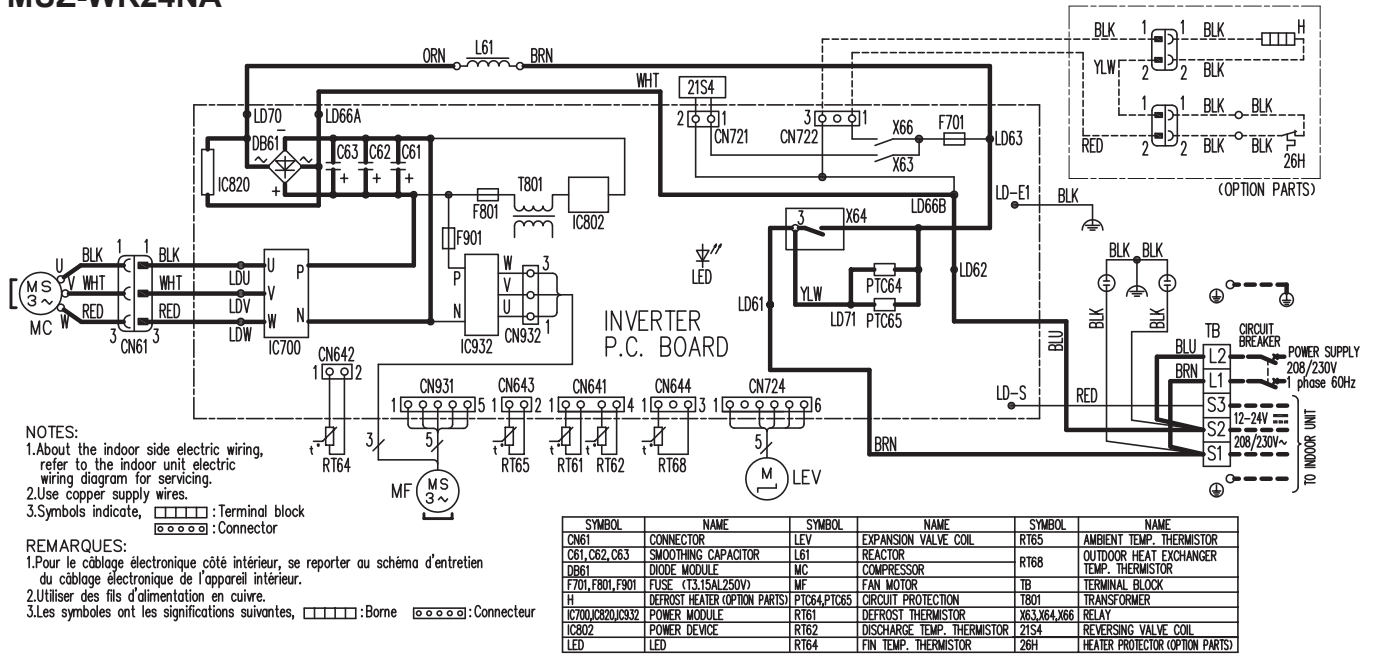

# 6

# REFRIGERANT SYSTEM DIAGRAM

## MUZ-WR09NA MUZ-WR12NA

Unit: Inch (mm)

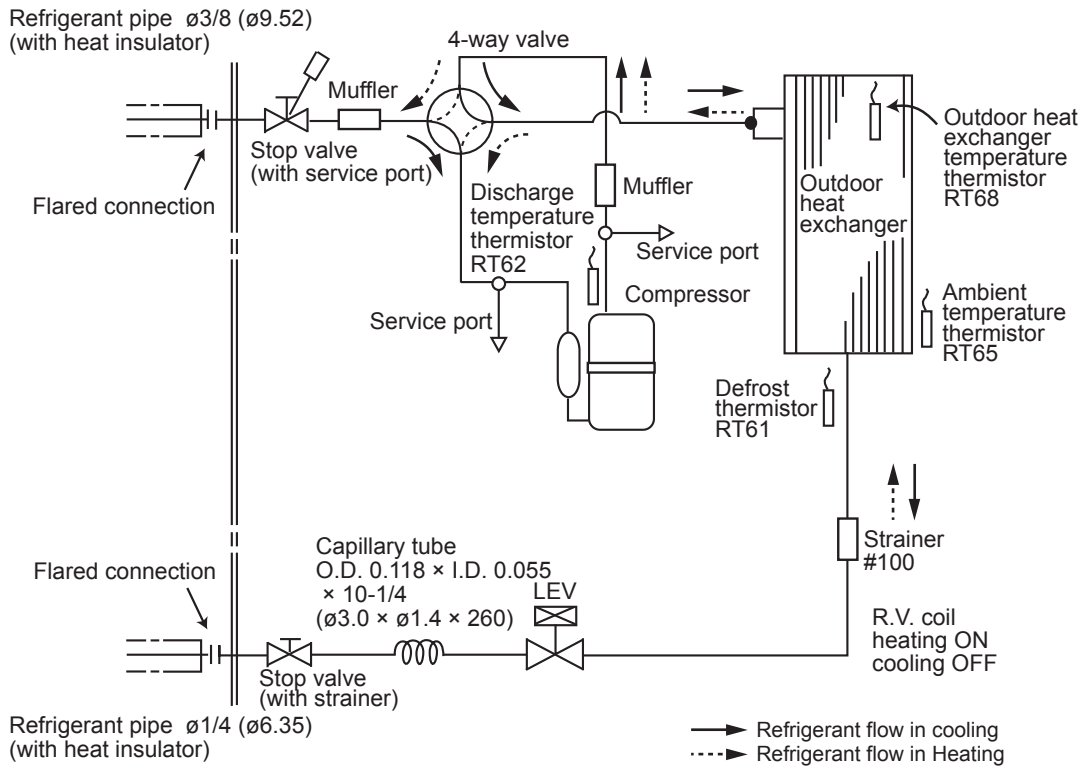

## MUZ-WR18NA

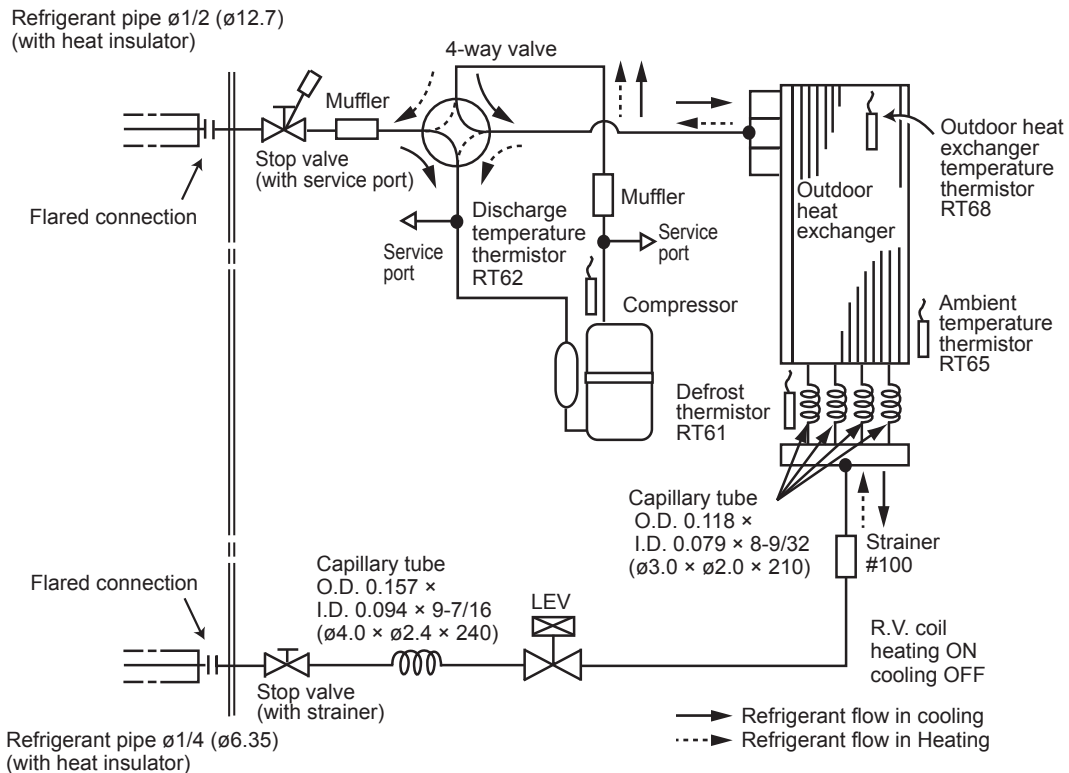

**MUZ-WR24NA**

**Unit: Inch (mm)**

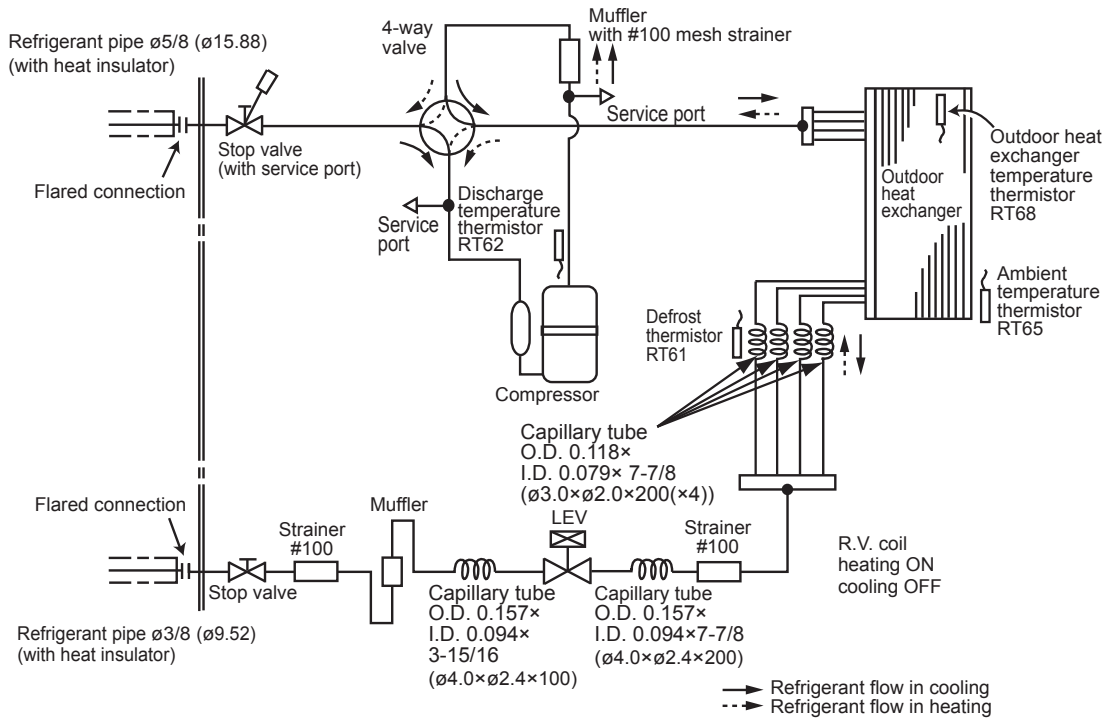

## MAX. REFRIGERANT PIPING LENGTH and MAX. HEIGHT DIFFERENCE

Model	Refrigerant piping: ft.		Piping size O.D: in.	
	Max. Length A	Max. Height difference B	Gas	Liquid
<b>MUZ-WR09NA</b> <b>MUZ-WR12NA</b>	65	40	3/8	1/4
<b>MUZ-WR18NA</b>			1/2	
<b>MUZ-WR24NA</b>	100	50	5/8	3/8

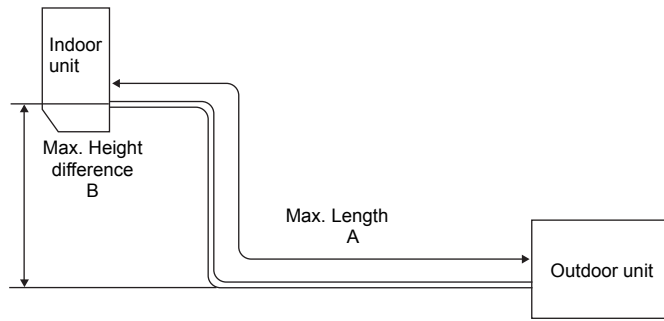

## ADDITIONAL REFRIGERANT CHARGE (R410A: oz.)

**NOTE:** Refrigerant piping exceeding 25 ft. requires additional refrigerant charge according to the calculation.

Model	Outdoor unit precharged	Refrigerant piping length (one way): ft.					
		25	30	40	50	60	65
<b>MUZ-WR09NA</b> <b>MUZ-WR12NA</b>	1 lb. 12 oz.	0	1.08	3.24	5.40	7.56	8.64
<b>MUZ-WR18NA</b>	2 lb. 10 oz.						

Calculation: X oz. = 1.08/5 oz./ft. × (Refrigerant piping length (ft.) - 25)

Model	Outdoor unit precharged	Refrigerant piping length (one way): ft.								
		25	30	40	50	60	70	80	90	100
<b>MUZ-WR24NA</b>	3 lb. 9 oz.	0	1.08	3.24	5.40	7.56	9.72	11.88	14.04	16.20

Calculation: X oz. = 1.08/5 oz./ft. × (Refrigerant piping length (ft.) - 25)

## MUZ-WR09NA MUZ-WR12NA MUZ-WR18NA MUZ-WR24NA

### 7-1. PERFORMANCE DATA

#### 1) COOLING CAPACITY

Model	Indoor air		Outdoor intake air DB temperature (°F)														
	IWB (°F)	75			85			95			105			115			
		TC	SHC	TPC	TC	SHC	TPC	TC	SHC	TPC	TC	SHC	TPC	TC	SHC	TPC	
MUZ-WR09NA	71	11.0	7.6	0.73	10.3	7.1	0.80	9.7	6.6	0.86	9.0	6.2	0.91	8.3	5.7	0.94	
	67	10.4	8.6	0.69	9.7	8.0	0.76	9.0	7.4	0.82	8.4	6.9	0.87	7.7	6.3	0.91	
	63	9.8	9.4	0.66	9.1	8.7	0.73	8.5	8.1	0.78	7.7	7.3	0.84	7.0	6.7	0.87	
MUZ-WR12NA	71	14.7	9.4	1.18	13.7	8.7	1.30	12.9	8.2	1.40	12.0	7.6	1.47	11.0	7.0	1.53	
	67	13.9	10.7	1.12	13.0	10.0	1.23	12.0	9.2	1.33	11.2	8.6	1.41	10.3	7.9	1.48	
	63	13.1	11.8	1.06	12.1	10.9	1.18	11.3	10.2	1.27	10.3	9.3	1.36	9.4	8.5	1.41	
MUZ-WR18NA	71	21.1	15.3	1.53	19.7	14.3	1.68	18.5	13.4	1.81	17.2	12.5	1.90	15.8	11.5	1.98	
	67	20.0	17.2	1.44	18.6	16.0	1.59	17.2	14.8	1.72	16.0	13.8	1.82	14.7	12.6	1.91	
	63	18.7	18.6	1.38	17.4	17.3	1.52	16.2	16.1	1.64	14.7	14.6	1.75	13.4	13.3	1.82	
MUZ-WR24NA	71	27.6	20.0	2.50	25.8	18.7	2.74	24.2	17.6	2.95	22.5	16.4	3.11	20.7	15.0	3.23	
	67	26.1	22.4	2.36	24.3	20.9	2.60	22.5	19.4	2.81	20.9	18.0	2.98	19.2	16.5	3.12	
	63	24.5	24.4	2.25	22.7	22.6	2.49	21.2	21.0	2.68	19.2	19.1	2.87	17.6	17.4	2.98	

NOTE: 1. IWB : Intake air wet-bulb temperature TC : Total Capacity (x10<sup>3</sup> Btu/h)  
 SHC : Sensible Heat Capacity (x10<sup>3</sup> Btu/h) TPC : Total Power Consumption (kW)  
 2. SHC is based on 80°F of indoor Intake air DB temperature.

#### 2) COOLING CAPACITY CORRECTIONS

Model	Refrigerant piping length (one way: ft.)			
	25 (std.)	40	65	100
MUZ-WR09NA MUZ-WR12NA	1.0	0.988	0.967	—
MUZ-WR18NA	1.0	0.985	0.963	—
MUZ-WR24NA	1.0	0.983	0.956	0.921

### 3) HEATING CAPACITY CORRECTIONS

Model	Refrigerant piping length (one way: ft.)			
	25 (std.)	40	65	100
MUZ-WR09NA MUZ-WR12NA MUZ-WR18NA	1.0	0.997	0.993	—
MUZ-WR24NA	1.0	0.997	0.993	0.987

### 4) HEATING CAPACITY

Model	Indoor air IDB (°F)	Outdoor intake air WB temperature (°F)													
		5		15		25		35		43		45		55	
		TC	TPC	TC	TPC	TC	TPC	TC	TPC	TC	TPC	TC	TPC	TC	TPC
MUZ-WR09NA	75	4.8	0.58	6.3	0.73	7.9	0.86	9.4	0.96	10.6	1.00	11.0	1.02	12.4	1.06
	70	5.2	0.55	6.7	0.71	8.2	0.84	9.6	0.93	10.9	0.98	11.2	1.00	12.7	1.04
	65	5.5	0.53	6.9	0.68	8.6	0.81	10.0	0.91	11.2	0.96	11.6	0.97	13.0	1.02
MUZ-WR12NA	75	5.4	0.64	7.1	0.81	8.8	0.95	10.6	1.06	11.9	1.12	12.3	1.13	13.9	1.18
	70	5.8	0.62	7.5	0.78	9.2	0.93	10.8	1.04	12.2	1.09	12.6	1.11	14.2	1.16
	65	6.1	0.59	7.7	0.75	9.6	0.90	11.2	1.01	12.6	1.06	12.9	1.08	14.5	1.13
MUZ-WR18NA	75	7.9	0.99	10.4	1.24	13.1	1.46	15.6	1.63	17.6	1.71	18.1	1.74	20.5	1.80
	70	8.6	0.94	11.1	1.20	13.5	1.43	15.9	1.59	18.0	1.67	18.5	1.70	21.0	1.77
	65	9.0	0.90	11.3	1.15	14.1	1.38	16.5	1.54	18.5	1.63	19.1	1.65	21.4	1.74
MUZ-WR24NA	75	11.4	1.58	15.1	2.00	18.9	2.35	22.5	2.61	25.4	2.75	26.1	2.79	29.6	2.89
	70	12.4	1.51	16.0	1.93	19.5	2.29	23.0	2.55	26.0	2.68	26.8	2.73	30.3	2.84
	65	13.0	1.45	16.4	1.85	20.4	2.21	23.8	2.48	26.8	2.61	27.6	2.65	30.9	2.79

**NOTE:** 1. IDB : Intake air dry-bulb temperature  
 TC : Total Capacity (x10<sup>3</sup> Btu/h)      TPC : Total Power Consumption (kW)  
 2. Above data is for heating operation without any frost.

How to operate with fixed operational frequency of the compressor

1. Press the EMERGENCY OPERATION switch on the front of the indoor unit, and select either EMERGENCY COOL mode or EMERGENCY HEAT mode before starting to operate the air conditioner.
2. The compressor starts with operational frequency.
3. The fan speed of the indoor unit is High.
4. This operation continues for 30 minutes.
5. In order to release this operation, press the EMERGENCY OPERATION switch or press any button on the remote controller.

## 7-2. PERFORMANCE CURVE

### Cooling

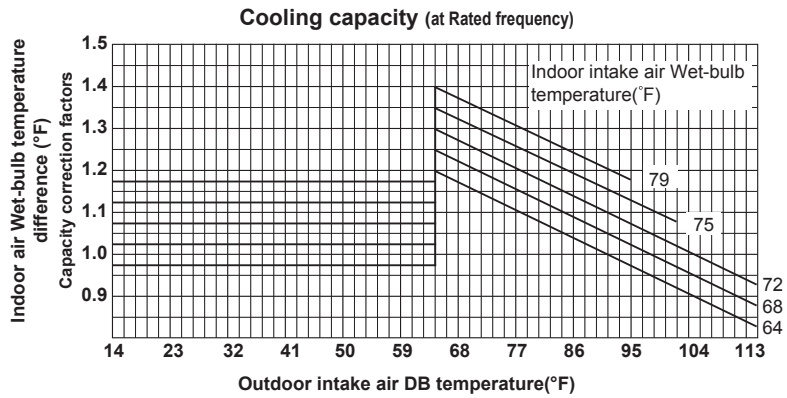

#### MUZ-WR09NA

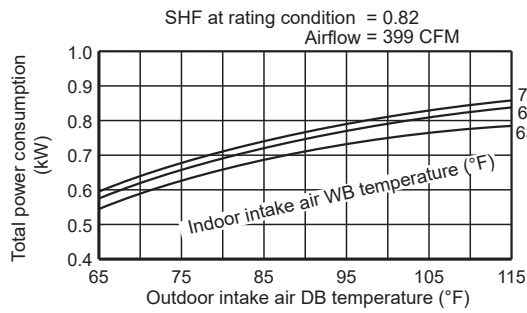

#### MUZ-WR12NA

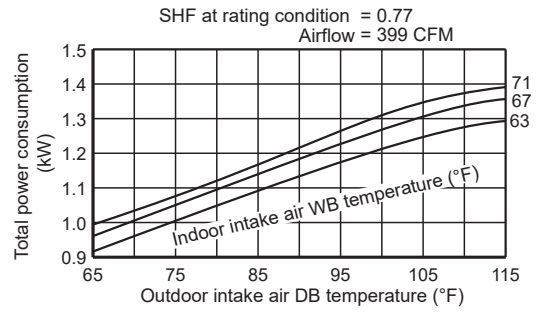

#### MUZ-WR18NA

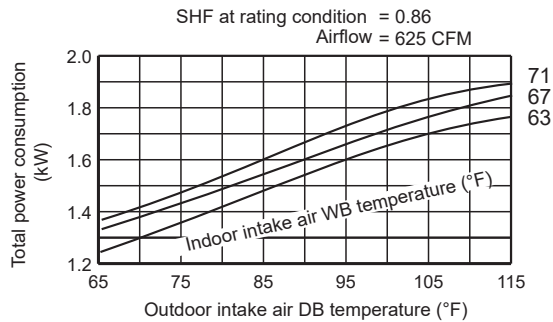

#### MUZ-WR24NA

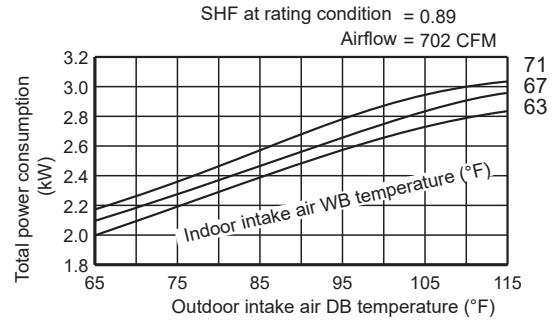

This value of frequency is not the same as the actual frequency in operating. Refer to 7-5 and 7-6 for the relationships between frequency and capacity.

## Heating

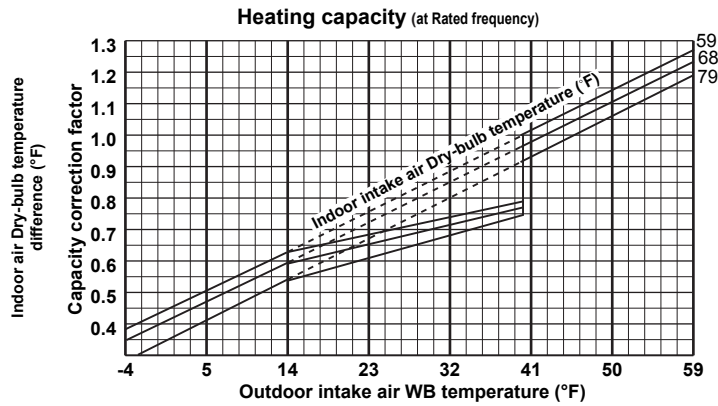

### MUZ-WR09NA

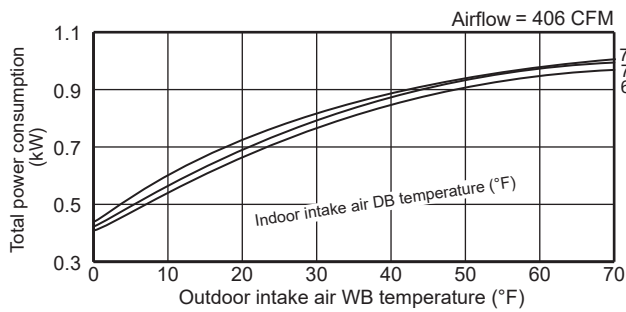

### MUZ-WR12NA

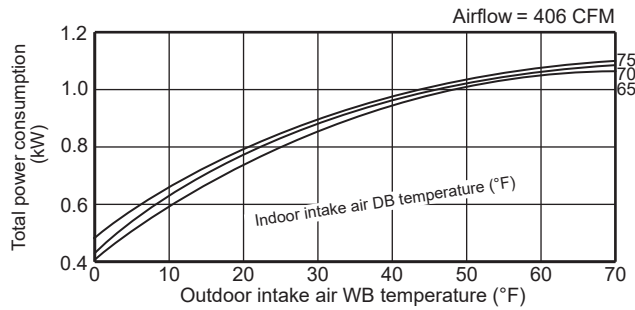

### MUZ-WR18NA

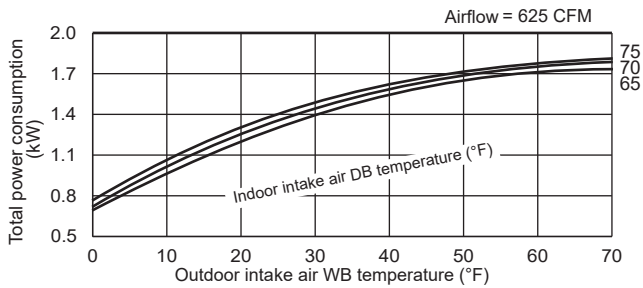

### MUZ-WR24NA

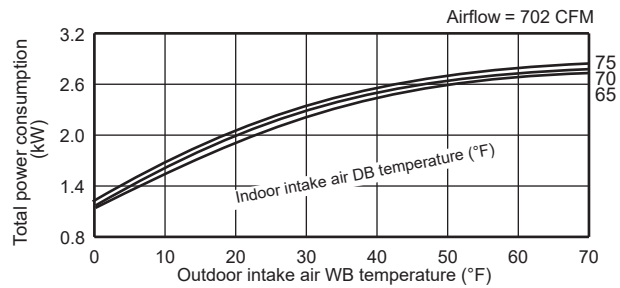

This value of frequency is not the same as the actual frequency in operating. Refer to 7-5 and 7-6 for the relationships between frequency and capacity.

### 7-3. CONDENSING PRESSURE

#### Cooling

Data is based on the condition of indoor humidity 50 %.

Air flow should be set to High speed.

#### MUZ-WR09NA

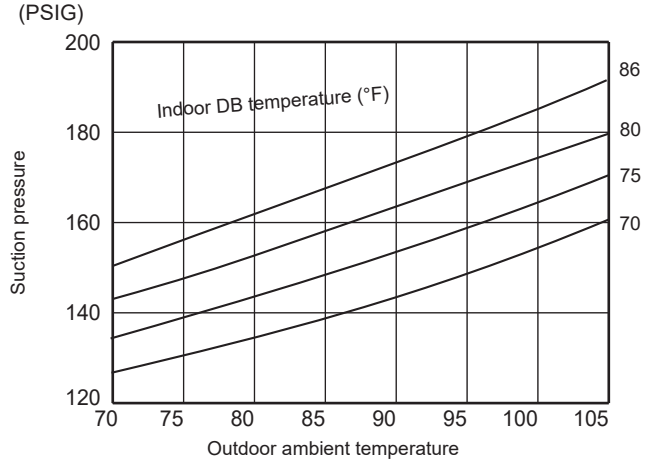
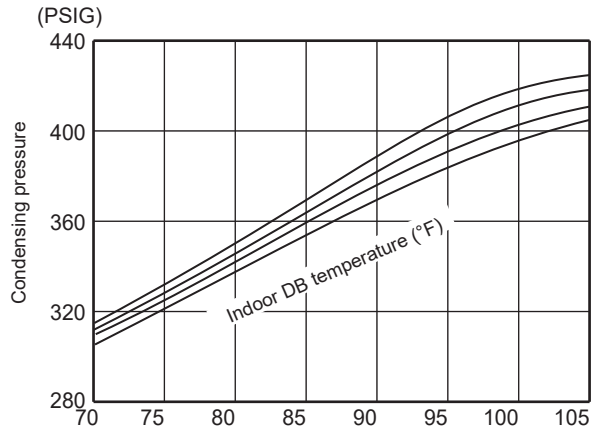

#### MUZ-WR12NA

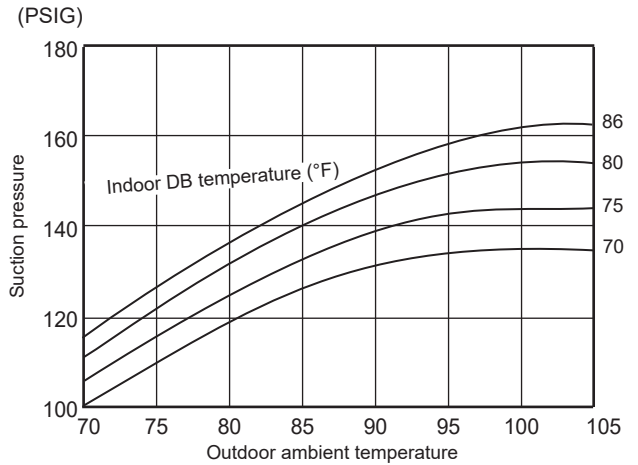
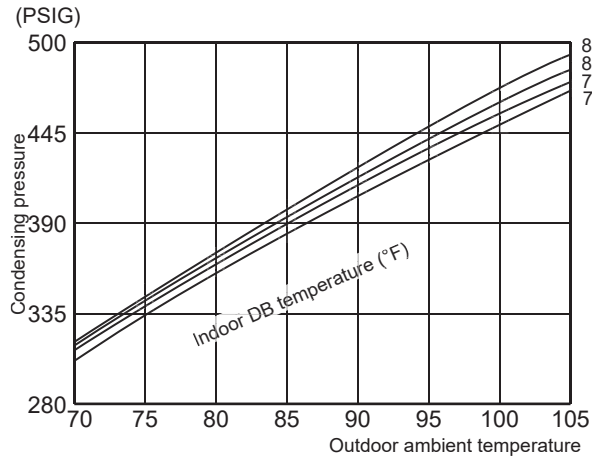

**MUZ-WR18NA**

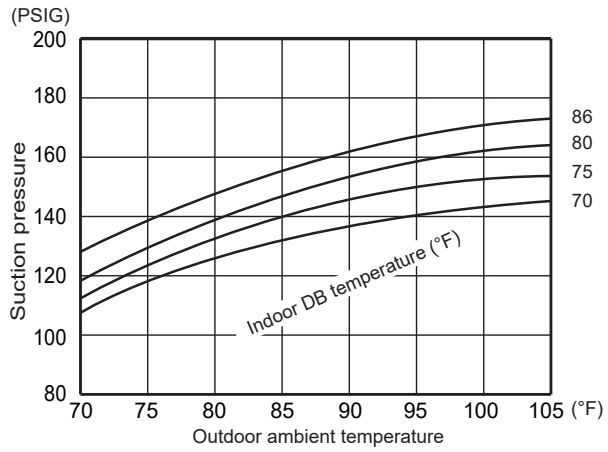
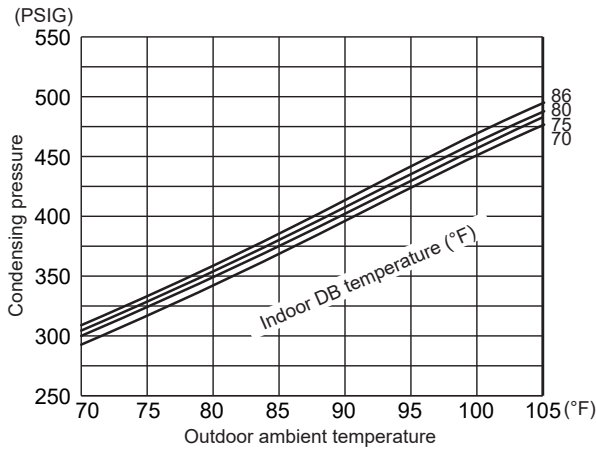

**MUZ-WR24NA**

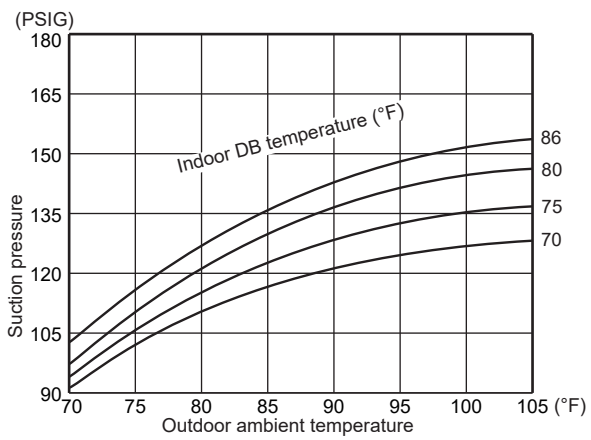
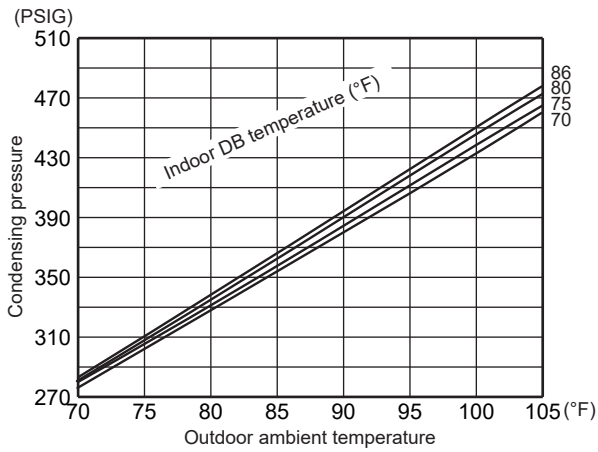

**Heating**

Data is based on the condition of outdoor humidity 75%.  
 Air flow should be set to High speed.  
 Data is for heating operation without any frost.

**MUZ-WR09NA MUZ-WR12NA**

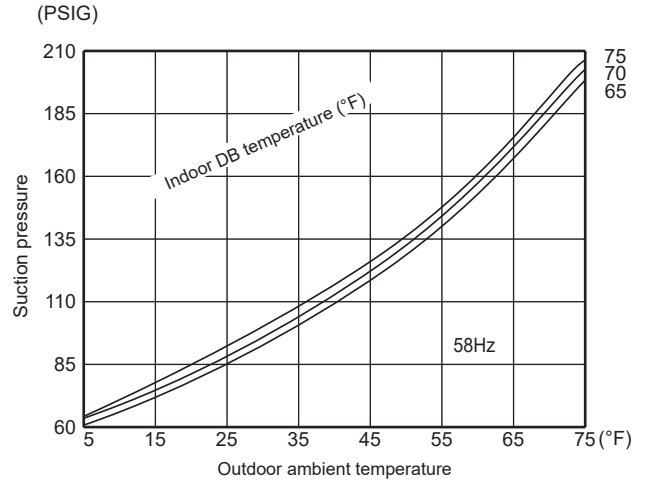
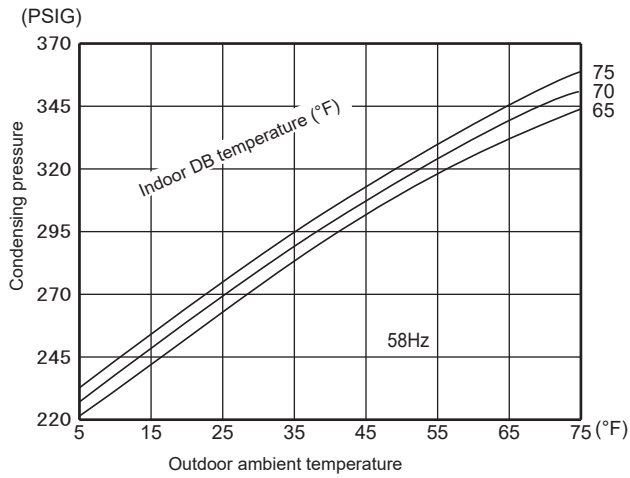

**MUZ-WR18NA**

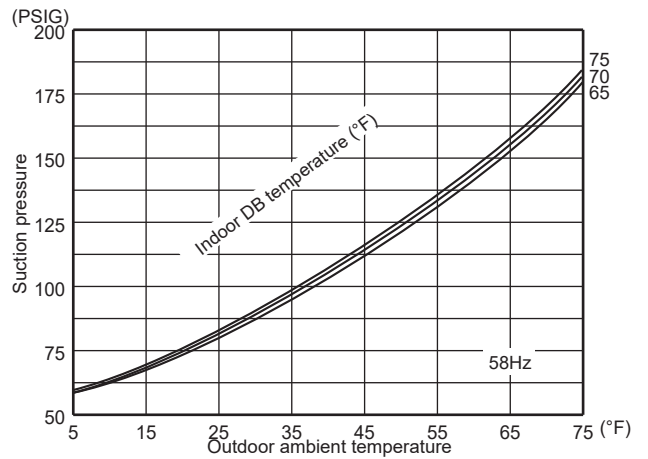
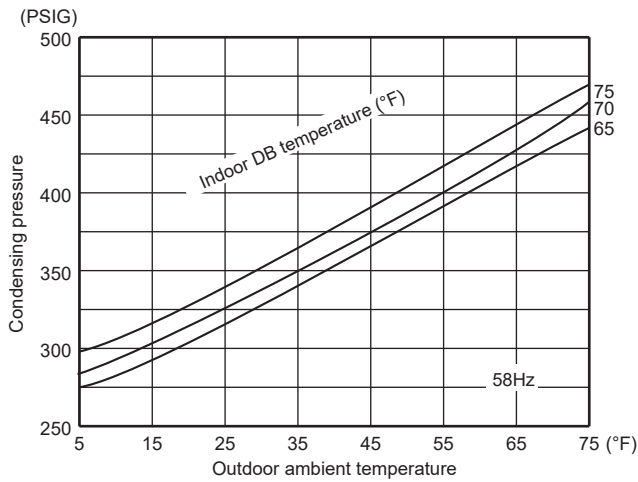

**MUZ-WR24NA**

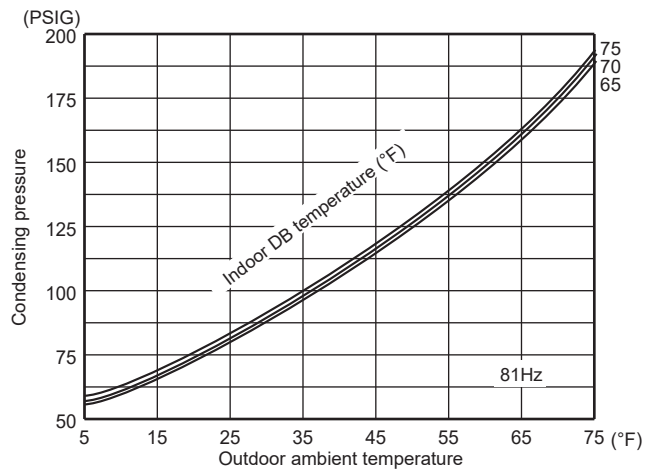
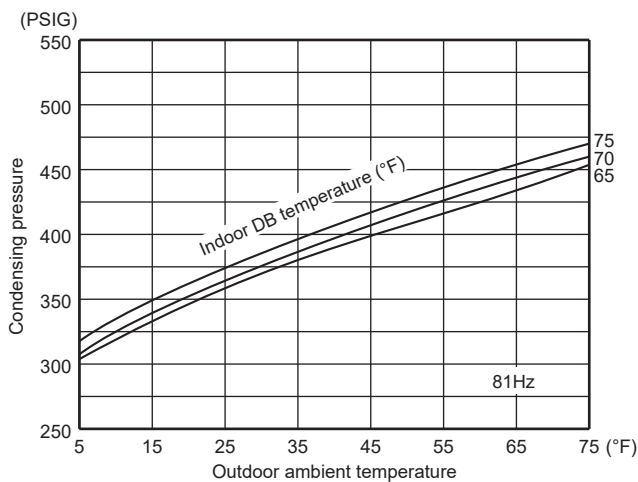

#### 7-4. STANDARD OPERATION DATA

Model			MSZ-WR09NA		MSZ-WR12NA		
Item		Unit	Cooling	Heating	Cooling	Heating	
Total	Capacity	Btu/h	9,000	10,900	12,000	12,200	
	SHF	—	0.82	—	0.77	—	
	Input	kW	0.750	0.900	1.210	0.990	
	Rated frequency	Hz	59.5	79.0	89.0	90.0	
Electrical circuit	Indoor unit		MSZ-WR09NA		MSZ-WR12NA		
	Power supply	V, phase, Hz	208/230, 1, 60				
	Input	kW	0.022	0.023	0.022	0.023	
	Fan motor current	A	0.24/0.22	0.25/0.23	0.24/0.22	0.25/0.23	
	Outdoor unit		MUZ-WR09NA		MUZ-WR12NA		
	Power supply	V, phase, Hz	208/230, 1, 60				
	Input	kW	0.728	0.877	1.188	0.967	
	Comp. current	A	3.64/3.29	4.25/3.85	5.61/5.08	4.56/4.13	
Refrigerant circuit	Fan motor current		A	0.27/0.24	0.30/0.27	0.27/0.24	0.30/0.27
	Condensing pressure	PSIG	384	331	429	347	
	Suction pressure	PSIG	152	102	135	99	
	Discharge temperature	°F	151	155	180	165	
	Condensing temperature	°F	113	101	120	104	
	Suction temperature	°F	58	41	60	41	
	Comp. shell bottom temperature	°F	146	149	174	157	
	Ref. pipe length	ft.	25				
Refrigerant charge (R410A)			1 lb. 12 oz.		1 lb. 12 oz.		
Indoor unit	Intake air temperature	DB	°F	80	70	80	70
		WB	°F	67	60	67	60
	Discharge air temperature	DB	°F	60	97	56	108
		WB	°F	58	—	55	—
	Fan speed (High)	rpm	1,020	1,040	1,020	1,040	
Airflow (High)	CFM	367 (Wet)	413	367 (Wet)	413		
Outdoor unit	Intake air temperature	DB	°F	95	47	95	47
		WB	°F	—	43	—	43
	Fan speed	rpm	800	850	800	850	
	Airflow	CFM	1151	1225	1151	1225	



Model			MSZ-WR18NA		MSZ-WR24NA		
Item		Unit	Cooling	Heating	Cooling	Heating	
Total	Capacity	Btu/h	17,200	18,000	22,500	26,000	
	SHF	—	0.86	—	0.89	—	
	Input	kW	1.64	1.59	2.63	2.5	
	Rated frequency	Hz	68	74	98	108	
Electrical circuit	Indoor unit		MSZ-WR18NA		MSZ-WR24NA		
	Power supply	V, phase, Hz	208/230, 1, 60				
	Input	kW	0.042	0.042	0.055		
	Fan motor current	A	0.44/0.40	0.44/0.40	0.55/0.50		
	Outdoor unit		MUZ-WR18NA		MUZ-WR24NA		
	Power supply	V, phase, Hz	208/230, 1, 60				
	Input	kW	1.598	1.548	2.575	2.445	
	Comp. current	A	7.22/6.53	7.11/6.43	11.11/10.05	10.56/9.55	
Refrigerant circuit	Fan motor current		A	0.41/0.37	0.40/0.36	1.05/0.95	1.05/0.95
	Condensing pressure	PSIG	423	361	404	403	
	Suction pressure	PSIG	144	99	127	94	
	Discharge temperature	°F	165	161	174	194	
	Condensing temperature	°F	120	108	116	116	
	Suction temperature	°F	54	35	54	44	
	Comp. shell bottom temperature	°F	149	143	173	192	
	Ref. pipe length	ft.	25				
Refrigerant charge (R410A)			2 lb. 10 oz.		3 lb. 9 oz.		
Indoor unit	Intake air temperature	DB	°F	80	70	80	70
		WB	°F	67	60	67	60
	Discharge air temperature	DB	°F	58	114	57	108
		WB	°F	56	—	56	—
	Fan speed (High)		rpm	1,140	1,140	1,250	1,250
Airflow (High)		CFM	562 (Wet)	625	632 (Wet)	702	
Outdoor unit	Intake air temperature	DB	°F	95	47	95	47
		WB	°F	—	43	—	43
	Fan speed		rpm	910	900	810	810
	Airflow		CFM	1,243	1,229	1,691	1,691

## 7-5. CAPACITY AND INPUT CORRECTION BY INVERTER OUTPUT FREQUENCY

### MUZ-WR09NA

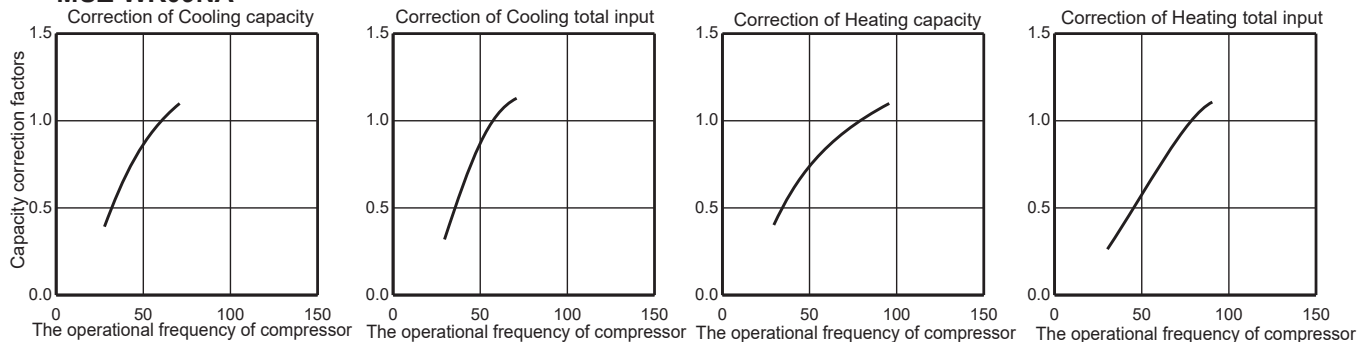

### MUZ-WR12NA

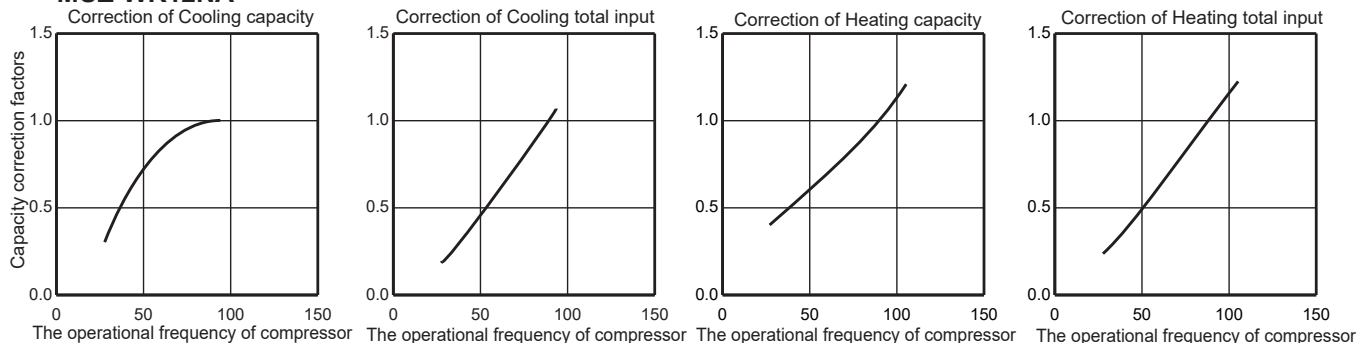

### MUZ-WR18NA

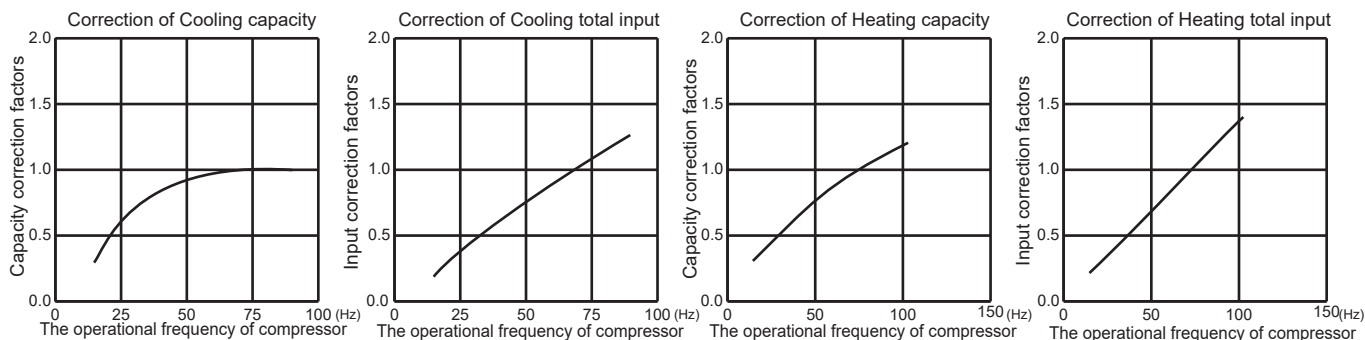

### MUZ-WR24NA

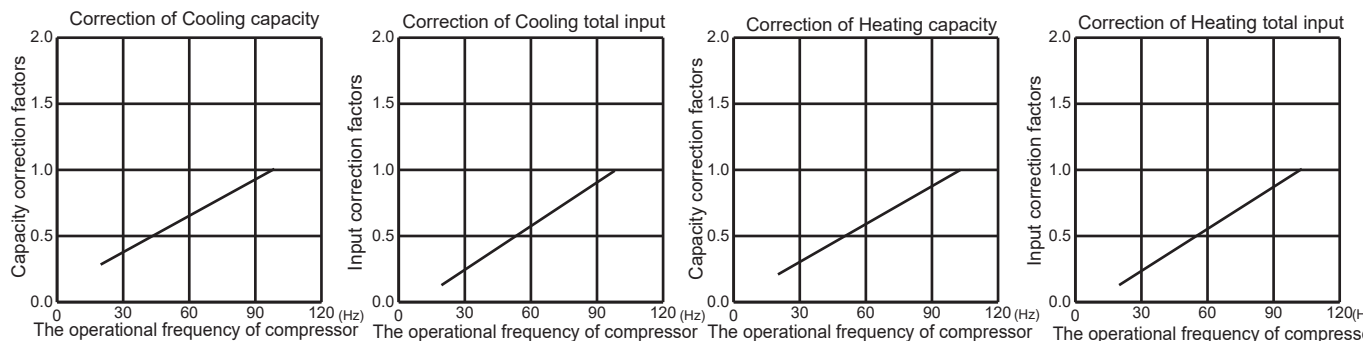

## 7-6. HOW TO OPERATE FIXED-FREQUENCY OPERATION (Test run operation)

1. Press EMERGENCY OPERATION switch to start COOL or HEAT mode (COOL: Press once, HEAT: Press twice).
2. Test run operation starts and continues to operate for 30 minutes.
3. Compressor operates at rated frequency in COOL mode or 58 Hz in HEAT mode.
4. Indoor fan operates at High speed.
5. After 30 minutes, test run operation finishes and EMERGENCY OPERATION starts (operation frequency of compressor varies).
6. To cancel test run operation (EMERGENCY OPERATION), press EMERGENCY OPERATION switch or any button on remote controller.

**MUZ-WR09NA MUZ-WR12NA MUZ-WR18NA MUZ-WR24NA**

**8-1. OUTDOOR FAN MOTOR CONTROL**

The fan motor turns ON/OFF, interlocking with the compressor.

[ON] The fan motor turns ON 5 seconds before the compressor starts up.

[OFF] The fan motor turns OFF 15 seconds after the compressor has stopped running.

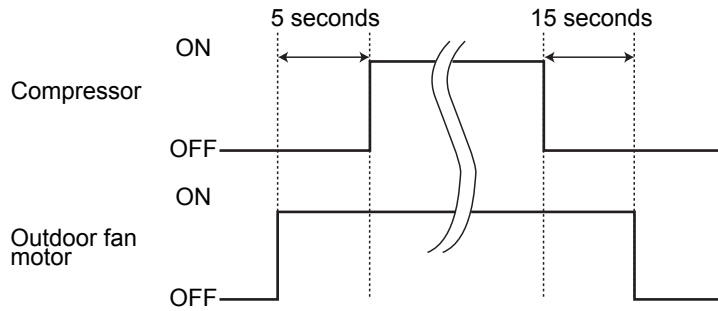

**8-2. R.V. COIL CONTROL**

Heating . . . . . ON

Cooling . . . . . OFF

Dry . . . . . OFF

**NOTE:** The 4-way valve reverses for 5 seconds right before start-up of the compressor.

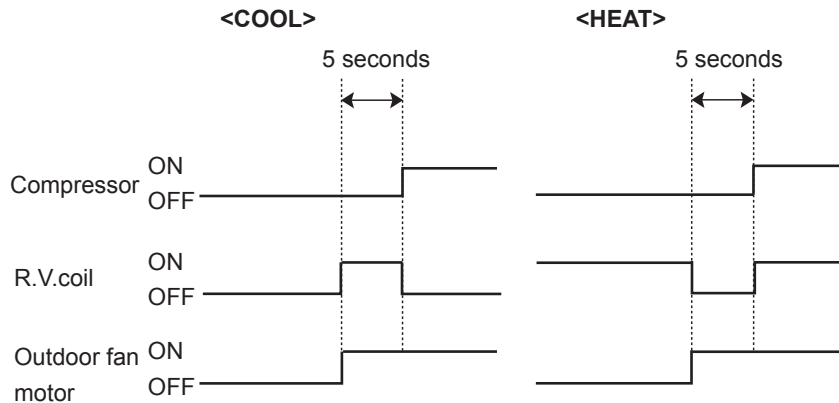

**8-3. RELATION BETWEEN MAIN SENSOR AND ACTUATOR**

Sensor	Purpose	Actuator					
		Compressor	LEV	Outdoor fan motor	R.V. coil	Indoor fan motor	Defrost heater *
Discharge temperature thermistor	Protection	○	○				
Indoor coil temperature thermistor	Cooling: Coil frost prevention	○					
	Heating: High pressure protection	○	○				
Defrost thermistor	Heating: Defrosting	○	○	○	○	○	
Fin temperature thermistor	Protection	○		○			
Ambient temperature thermistor	Cooling: Low ambient temperature operation	○	○	○			
	Heating: Defrosting (Heater)						○
Outdoor heat exchanger temperature thermistor	Cooling: Low ambient temperature operation	○	○	○			
	Cooling: High pressure protection	○	○	○			

\* Optional parts

**MUZ-WR09NA MUZ-WR12NA MUZ-WR18NA MUZ-WR24NA****9-1. CHANGE IN DEFROST SETTING****Changing defrost finish temperature**

<JS> To change the defrost finish temperature, cut/solder the JS wire of the outdoor inverter P.C. board (Refer to 10-6.1.).

Jumper		Defrost finish temperature		
		MUZ-WR09/12	MUZ-WR18	MUZ-WR24
JS	Soldered (Initial setting)	52°F (11°C)	41°F (5°C)	50°F (10°C)
	None (Cut)	52°F (11°C)	50°F (10°C)	64°F (18°C)

**9-2. PRE-HEAT CONTROL SETTING**

When moisture gets into the refrigerant cycle, it may interfere with the start-up of the compressor at low outside temperature. The pre-heat control prevents this interference. The pre-heat control turns ON when the discharge temperature thermistor is 68°F (20°C) or below. When the pre-heat control turns ON, the compressor is energized. (About 50 W)

**Pre-heat control setting**

<JK>

ON: To activate the pre-heat control, cut JK wire of the inverter P.C. board.

OFF: To deactivate the pre-heat control, solder JK wire of the inverter P.C. board.

(Refer to 10-6.1)

Jumper		Pre-heat control setting
JK	Soldered	Deactivated (Factory setting)
	Cut	Activated

**NOTE:** When the inverter P.C. board is replaced, check the jumper wires, and cut/solder them if necessary.

**MUZ-WR09NA MUZ-WR12NA MUZ-WR18NA MUZ-WR24NA****10-1. CAUTIONS ON TROUBLESHOOTING****1. Before troubleshooting, check the following**

- 1) Check the power supply voltage.
- 2) Check the indoor/outdoor connecting wire for miswiring.

**2. Take care of the following during servicing**

- 1) Before servicing the air conditioner, be sure to turn OFF the main unit first with the remote controller, then after confirming the horizontal vane is closed, turn off the breaker and/or disconnect the power plug.
- 2) Be sure to turn OFF the power supply before removing the front panel, the cabinet, the top panel, and the electronic control P.C. board.
- 3) When removing the electrical parts, be careful of the residual voltage of smoothing capacitor.
- 4) When removing the electronic control P.C. board, hold the edge of the board with care NOT to apply stress on the components.

&lt;Incorrect&gt;

**Lead wiring**

&lt;Correct&gt;

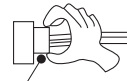
**Connector housing**

- 5) When connecting or disconnecting the connectors, hold the connector housing. DO NOT pull the lead wires.

**3. Troubleshooting procedure**

- 1) Check if the OPERATION INDICATOR lamp on the indoor unit is blinking on and off to indicate an abnormality. To make sure, check how many times the OPERATION INDICATOR lamp is blinking on and off before starting service work. (See the service manual of the indoor unit for a description of those failure codes.)
- 2) Before servicing, check that the connector and terminal are connected properly.
- 3) When the electronic control P.C. board seems to be defective, check the copper foil pattern for disconnection and the components for bursting and discoloration.
- 4) Refer to 10-2 and 10-3.

## 10-2. FAILURE MODE RECALL FUNCTION

Outline of the function

This air conditioner can memorize the abnormal condition which has occurred once.

Even though LED indication listed on the troubleshooting check table (10-3.) disappears, the memorized failure details can be recalled.

### 1. Flow chart of failure mode recall function for the indoor/outdoor unit

Operational procedure

The cause of abnormality cannot be found because the abnormality does not recur.

Setting up the failure mode recall function

Turn ON the power supply.  
 <Preparation of the remote controller>  
 ① While pressing OPERATION SELECT button and TOO COOL button on the remote controller at the same time, press RESET button.  
 ② First, release RESET button.  
 Hold down the other 2 buttons for another 3 seconds. Make sure that the indicators on the LCD screen shown in the right figure are all displayed. Then release the buttons.

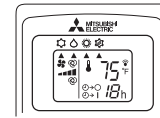
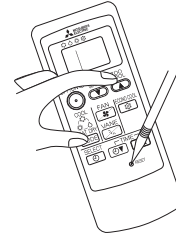

Press STOP/OPERATE (OFF/ON) button of the remote controller (the set temperature is displayed) with the remote controller headed towards the indoor unit. ※1

※1. Regardless of normal or abnormal condition, a short beep is emitted once the signal is received.

Does the upper lamp of the OPERATION INDICATOR lamp on the indoor unit blink at the interval of 0.5 seconds?  
 Blinks: Either indoor or outdoor unit is abnormal. Beep is emitted at the same timing as the blinking of the upper lamp of the OPERATION INDICATOR lamp. ※2

No (OFF)

Indoor unit is normal.  
 But the outdoor unit might be abnormal because there are some abnormalities that cannot be recalled with this way.  
 Check if outdoor unit is abnormal according to the detailed outdoor unit failure mode recall function. (Refer to 10-2.2)

Judgment of indoor/outdoor abnormality

Before blinking, does the upper lamp of the OPERATION INDICATOR lamp stay ON for 3 seconds?  
 When it stays ON for 3 seconds (without beep): The outdoor unit is abnormal.

Yes

The indoor unit is abnormal.  
 Check the blinking pattern, and identify the abnormal point by referring to the table of indoor unit failure mode recall function. (Refer to indoor unit service manual.)  
 Make sure to check at least 2 consecutive blinking cycles. ※2

The outdoor unit is abnormal.  
 Check the blinking pattern, and identify the abnormal point by referring to the table of outdoor unit failure mode recall function. (Refer to 10-2.3)  
 Make sure to check at least 2 consecutive blinking cycles. ※3

Releasing the failure mode recall function

Release the failure mode recall function by the following procedures.  
 Turn OFF the power supply and turn it ON again.  
 Press RESET button of the remote controller.

Repair the failure parts.

Deleting the memorized abnormal condition

① After repairing the unit, recall the failure mode again according to "Setting up the failure mode recall function" mentioned above.  
 ② Press STOP/OPERATE (OFF/ON) button of the remote controller (the set temperature is displayed) with the remote controller headed towards the indoor unit.  
 ③ Press EMERGENCY OPERATION switch so that the memorized abnormal condition is deleted.  
 ④ Release the failure mode recall function according to "Releasing the failure mode recall function" mentioned above.

NOTE: 1. Make sure to release the failure mode recall function after it is set up, otherwise the unit cannot operate properly.  
 2. If the abnormal condition is not deleted from the memory, the last abnormal condition is kept memorized.

※2. Blinking pattern when the indoor unit is abnormal:

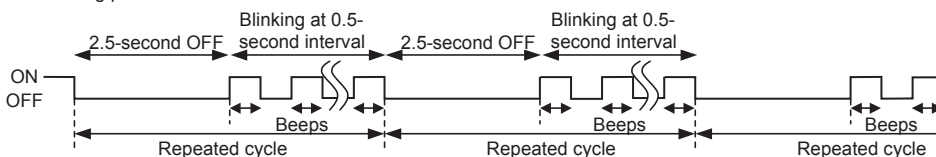

※3. Blinking pattern when the outdoor unit is abnormal:

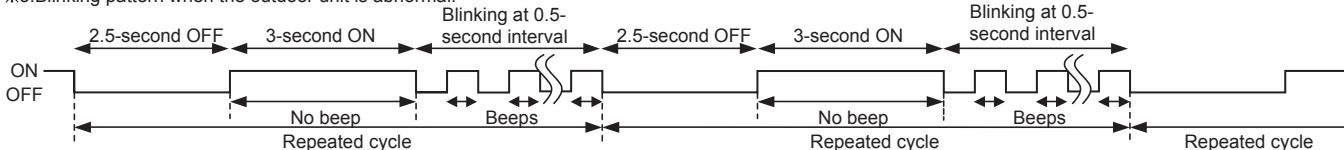

## 2. Flow chart of the detailed outdoor unit failure mode recall function

Operational procedure

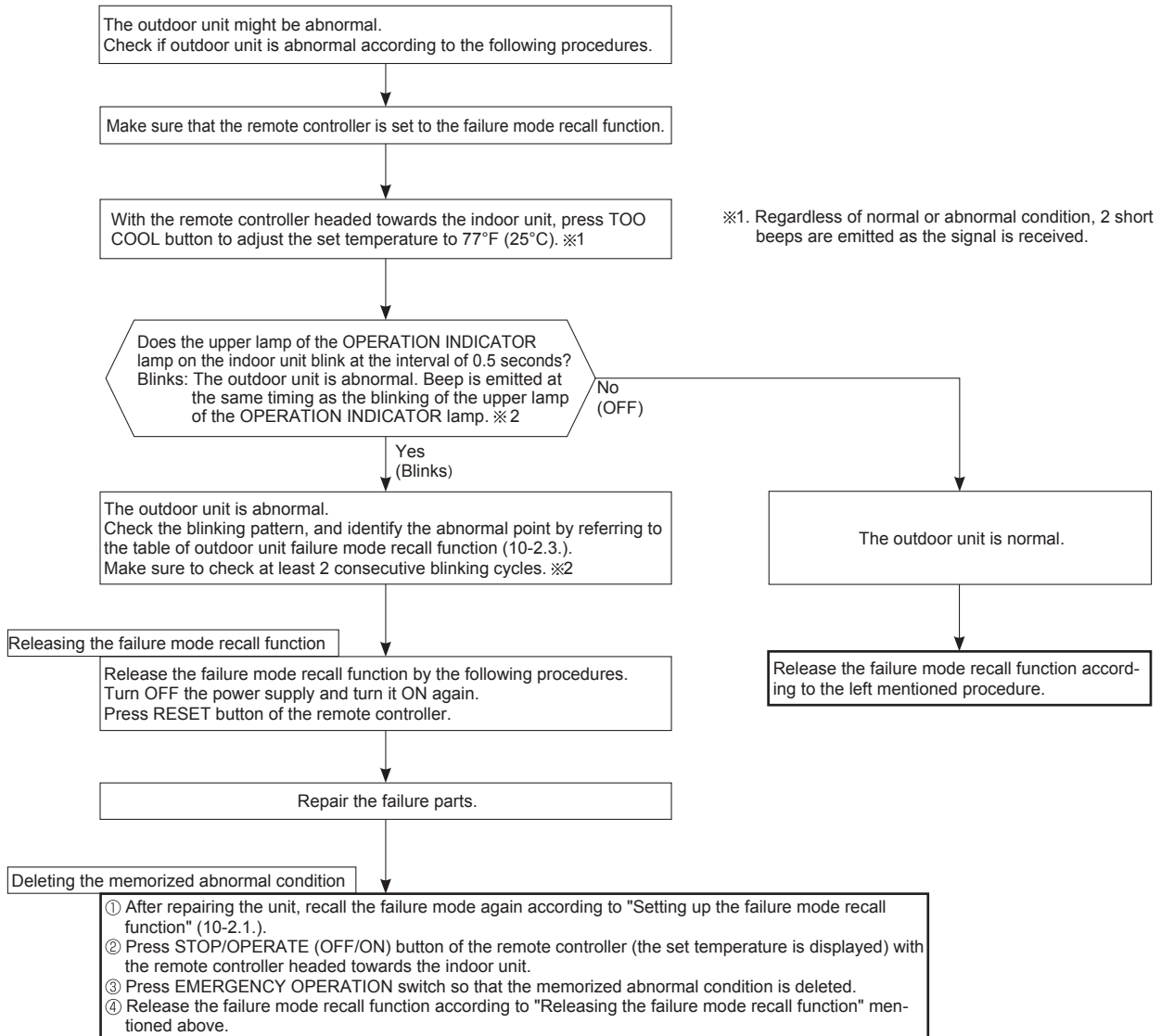

**NOTE:** 1. Make sure to release the failure mode recall function after it is set up, otherwise the unit cannot operate properly.  
2. If the abnormal condition is not deleted from the memory, the last abnormal condition is kept memorized.

※2. Blinking pattern when outdoor unit is abnormal:

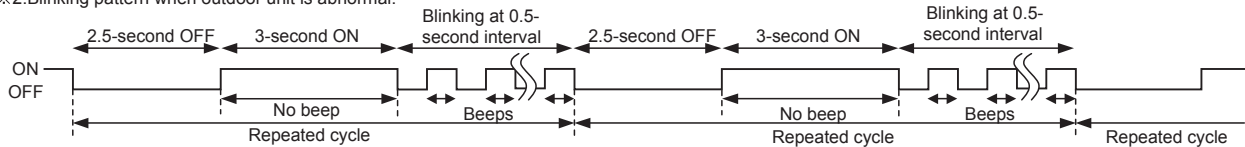

3. Table of outdoor unit failure mode recall function

NOTE: Blinking patterns of this mode differ from the ones of TROUBLESHOOTING CHECK TABLE (10-3.).

MUZ-WR09NA MUZ-WR12NA

OPERATION INDICATOR upper lamp (Indoor unit)	Abnormal point (Failure mode / protection)	LED indication (Outdoor P.C. board)	Condition	Remedy	Indoor/ outdoor unit failure mode recall function	Outdoor unit failure mode recall function
OFF	None (Normal)	—	—	—	—	—
2-time blink 2.5 seconds OFF	Outdoor power system	—	Overcurrent protection cut-out operates 3 consecutive times within 1 minute after the compressor gets started.	<ul style="list-style-type: none"> <li>Reconnect connectors.</li> <li>Refer to 10-5. Ⓐ "How to check inverter/ compressor".</li> <li>Check the stop valve.</li> </ul>	○	○
3-time blink 2.5 seconds OFF	Discharge temperature thermistor	1-time blink every 2.5 seconds	Thermistor shorts or opens during compressor running.	<ul style="list-style-type: none"> <li>Refer to 10-5. Ⓑ "Check of outdoor thermistors". Defective outdoor thermistors can be identified by checking the blinking pattern of LED.</li> </ul>	○	○
	Defrost thermistor					
	Fin temperature thermistor	3-time blink 2.5 seconds OFF				
	P.C. board temperature thermistor	4-time blink 2.5 seconds OFF				
4-time blink 2.5 seconds OFF	Overcurrent	11-time blink 2.5 seconds OFF	Large current flows into intelligent power module/ power module ※1.	<ul style="list-style-type: none"> <li>Reconnect compressor connector.</li> <li>Refer to 10-5. Ⓐ "How to check inverter/ compressor".</li> <li>Check the stop valve.</li> </ul>	—	○
	Compressor synchronous abnormality (Compressor start-up failure protection)	12-time blink 2.5 seconds OFF	Waveform of compressor current is distorted.	<ul style="list-style-type: none"> <li>Reconnect compressor connector.</li> <li>Refer to 10-5. Ⓐ "How to check inverter/ compressor".</li> </ul>	—	○
5-time blink 2.5 seconds OFF	Discharge temperature	—	Temperature of discharge temperature thermistor exceeds 241°F (116°C), compressor stops. Compressor can restart if discharge temperature thermistor reads 212°F (100°C) or less 3 minutes later.	<ul style="list-style-type: none"> <li>Check the refrigerant circuit and the refrigerant amount.</li> <li>Refer to 10-5. Ⓒ "Check of LEV".</li> </ul>	—	○
6-time blink 2.5 seconds OFF	High pressure	—	Temperature of indoor coil thermistor exceeds 158°F (70°C) in HEAT mode. Temperature of outdoor heat exchanger temperature thermistor exceeds 158°F (70°C) in COOL mode.	<ul style="list-style-type: none"> <li>Check the refrigerant circuit and the refrigerant amount.</li> <li>Check the stop valve.</li> </ul>	—	○
7-time blink 2.5 seconds OFF	Fin temperature/ P.C. board temperature	7-time blink 2.5 seconds OFF	Temperature of fin temperature thermistor on the inverter P.C. board exceeds 167 - 176°F (75 - 80°C), or temperature of P.C. board temperature thermistor on the inverter P.C. board exceeds 158 - 167°F (70 - 75°C).	<ul style="list-style-type: none"> <li>Check around the outdoor unit.</li> <li>Check the outdoor unit air passage.</li> <li>Refer to 10-5. Ⓓ "Check of outdoor fan motor".</li> </ul>	—	○
8-time blink 2.5 seconds OFF	Outdoor fan motor	—	Outdoor fan has stopped 3 times in a row within 30 seconds after outdoor fan start-up.	<ul style="list-style-type: none"> <li>Refer to 10-5. Ⓓ "Check of outdoor fan motor".</li> <li>Refer to 10-5. Ⓓ "Check of inverter P.C. board".</li> </ul>	—	○
9-time blink 2.5 seconds OFF	Nonvolatile memory data	5-time blink 2.5 seconds OFF	Nonvolatile memory data cannot be read properly.	<ul style="list-style-type: none"> <li>Replace the inverter P.C. board.</li> </ul>	○	○
10-time blink 2.5 seconds OFF	Discharge temperature	—	Temperature of discharge temperature thermistor has been 122°F (50°C) or less for 20 minutes.	<ul style="list-style-type: none"> <li>Refer to 10-5. Ⓒ "Check of LEV".</li> <li>Check the refrigerant circuit and the refrigerant amount.</li> </ul>	—	○

**NOTE:** Blinking patterns of this mode differ from the ones of TROUBLESHOOTING CHECK TABLE (10-3.).

OPERATION INDICATOR upper lamp (Indoor unit)	Abnormal point (Failure mode / protection)	LED indication (Outdoor P.C. board)	Condition	Remedy	Indoor/ outdoor unit failure mode recall function	Outdoor unit failure mode recall function
11-time blink 2.5 seconds OFF	Bus-bar voltage (DC)	8-time blink 2.5 seconds OFF	Bus-bar voltage of inverter cannot be detected normally.	•Refer to 10-5. Ⓐ "How to check inverter/ compressor".	—	○
	Each phase current of compressor	9-time blink 2.5 seconds OFF	Each phase current of compressor cannot be detected normally.			
12-time blink 2.5 seconds OFF	Overcurrent Compressor open-phase	10-time blink 2.5 seconds OFF	Large current flows into intelligent power module (IPM)/power module (IPM) *1. The open-phase operation of compressor is detected. The interphase short circuit occurs in the output of the intelligent power module (IPM)/power module (IPM) *1. The compressor winding shorts circuit.	•Reconnect compressor connector. •Refer to 10-5. Ⓐ "How to check inverter/ compressor".	—	○
14-time blink 2.5 seconds OFF	Stop valve (Closed valve)	14-time blink 2.5 seconds OFF	Closed valve is detected by compressor current.	•Check the stop valve	○	○
	4-way valve/ Pipe temperature	16-time blink 2.5 seconds OFF	The 4-way valve does not work properly. The indoor coil thermistor detects an abnormal temperature.	•Check the 4-way valve. •Replace the inverter P.C. board.		
16-time blink 2.5 seconds OFF	Outdoor refrigerant system abnormality	1-time blink 2.5 seconds OFF	A closed valve and air trapped in the refrigerant circuit are detected based on the temperature sensed by the indoor and outdoor thermistors and the current of the compressor.	•Check for a gas leak in a connecting piping etc. •Check the stop valve. •Refer to 10-5. Ⓒ "Check of outdoor refrigerant circuit".	○	○

**NOTE:** Blinking patterns of this mode differ from the ones of TROUBLESHOOTING CHECK TABLE (10-3.).

**MUZ-WR18NA MUZ-WR24NA**

The upper lamp of the OPERATION INDICATOR lamp (Indoor unit)	Abnormal point (Failure mode/protection)	LED indication (Outdoor P.C. board)	Condition	Remedy	Indoor/outdoor unit failure mode recall function	Outdoor unit failure mode recall function
OFF	None (Normal)	—	—	—	—	—
1-time blink 2.5 seconds OFF	Indoor/outdoor communication, receiving error	—	Any signals from the inverter P.C. board cannot be received normally for 3 minutes.	•Refer to 10-5. ㉔ How to check miswiring and serial signal error.	○	○
	Indoor/outdoor communication, receiving error	—	Although the inverter P.C. board sends signal "0", signal "1" has been received 30 consecutive times.	•Refer to 10-5. ㉔ How to check miswiring and serial signal error.		
2-time blink 2.5 seconds OFF	Outdoor power system	—	Overcurrent protection cut-out operates 3 consecutive times within 1 minute after the compressor gets started.	•Reconnect connectors. •Refer to 10-5. ㉔ How to check inverter/compressor". •Check stop valve.	○	○
3-time blink 2.5 seconds OFF	Discharge temperature thermistor	1-time blink every 2.5 seconds	Thermistor shorts or opens during compressor running.	•Refer to 10-5. ㉔ "Check of outdoor thermistors". Defective outdoor thermistors can be identified by checking the blinking pattern of LED.	○	○
	Defrost thermistor					
	Fin temperature thermistor	3-time blink 2.5 seconds OFF				
	P.C. board temperature thermistor	4-time blink 2.5 seconds OFF				
	Ambient temperature thermistor	2-time blink 2.5 seconds OFF				
Outdoor heat exchanger temperature thermistor	—					
4-time blink 2.5 seconds OFF	Overcurrent	11-time blink 2.5 seconds OFF	Large current flows into the power module (IC700).	•Reconnect compressor connector. •Refer to 10-5. ㉔ How to check inverter/compressor". •Check stop valve.	—	○
	Compressor synchronous abnormality (Compressor start-up failure protection)	12-time blink 2.5 seconds OFF	Waveform of compressor current is distorted.	•Reconnect compressor connector. •Refer to 10-5. ㉔ How to check inverter/compressor".	—	○
5-time blink 2.5 seconds OFF	Discharge temperature	—	Temperature of discharge temperature thermistor exceeds 241°F (116°C), compressor stops. Compressor can restart if discharge temperature thermistor reads 212°F (100°C) or less 3 minutes later.	•Check refrigerant circuit and refrigerant amount. •Refer to 10-5. ㉔ Check of LEV".	—	○
6-time blink 2.5 seconds OFF	High pressure	—	Temperature indoor coil thermistor exceeds 158°F (70°C) in HEAT mode. Temperature defrost thermistor exceeds 158°F (70°C) in COOL mode.	•Check refrigerant circuit and refrigerant amount. •Check stop valve.	—	○
7-time blink 2.5 seconds OFF	Fin temperature/ P.C. board temperature	7-time blink 2.5 seconds OFF	Temperature of the fin temperature thermistor on the inverter P.C. board exceeds 167 - 187°F (75 - 86°C), or temperature of P.C. board temperature thermistor on the inverter P.C. board exceeds 162 - 185°F (72 - 85°C).	•Check around outdoor unit. •Check outdoor unit air passage. •Refer to 10-5. ㉔ Check of outdoor fan motor".	—	○
8-time blink 2.5 seconds OFF	Outdoor fan motor	—	Outdoor fan has stopped 3 times in a row within 30 seconds after outdoor fan start-up.	•Refer to 10-5. ㉔ Check of outdoor fan motor". Refer to 10-5. ㉔ Check of inverter P.C. board".	—	○
9-time blink 2.5 seconds OFF	Nonvolatile memory data	5-time blink 2.5 seconds OFF	Nonvolatile memory data cannot be read properly.	•Replace the inverter P.C. board.	○	○
	Power module (IC700)	6-time blink 2.5 seconds OFF	The interface short circuit occurs in the output of the power module (IC700). The compressor winding shorts circuit.	•Refer to 10-5. ㉔ How to check inverter/compressor".	—	

**NOTE:** Blinking patterns of this mode differ from the ones of TROUBLESHOOTING CHECK TABLE (10-3.).

The upper lamp of the OPERATION INDICATOR lamp (Indoor unit)	Abnormal point (Failure mode/protection)	LED indication (Outdoor P.C. board)	Condition	Remedy	Indoor/outdoor unit failure mode recall function	Outdoor unit failure mode recall function
10-time blink 2.5 seconds OFF	Discharge temperature	—	Temperature of discharge temperature thermistor has been 122°F (50°C) or less for 20 minutes.	•Refer to 10-5.⑧"Check of LEV". •Check refrigerant circuit and refrigerant amount.	—	○
11-time blink 2.5 seconds OFF	Bus-bar voltage (DC)	8-time blink 2.5 seconds OFF	Bus-bar voltage of inverter cannot be detected normally.	•Refer to 10-5.⑨"How to check inverter/compressor".	—	○
	Each phase current of compressor	9-time blink 2.5 seconds OFF	Each phase current of compressor cannot be detected normally.			
14-time blink 2.5 seconds OFF	Stop valve (Closed valve)	14-time blink 2.5 seconds OFF	Closed valve is detected by compressor current.	•Check stop valve.	○	○
	4-way valve/ Pipe temperature	16-time blink 2.5 seconds OFF	The 4-way valve does not work properly. The indoor coil thermistor detects an abnormal temperature.	•Check the 4-way valve. •Replace the inverter P.C. board.		
16-time blink 2.5 seconds OFF	Outdoor refrigerant system abnormality	1-time blink 2.5 seconds OFF	A closed valve and air trapped in the refrigerant circuit are detected based on the temperature sensed by the indoor and outdoor thermistors and the current of the compressor.	•Check for a gas leak in a connecting piping etc. •Check the stop valve. •Refer to 10-5. ⑩ "Check of outdoor refrigerant circuit".	○	○

### 10-3. TROUBLESHOOTING CHECK TABLE

No.	Symptom	LED indication	Abnormal point/ Condition	Condition	Remedy	
1	Outdoor unit does not operate.	1-time blink every 2.5 seconds	Outdoor power system	Overcurrent protection cut-out operates 3 consecutive times within 1 minute after the compressor gets started.	<ul style="list-style-type: none"> <li>•Reconnect connector of compressor.</li> <li>•Refer to 10-5.Ⓐ "How to check inverter/compressor".</li> <li>•Check stop valve.</li> </ul>	
2			Outdoor thermistors	Discharge temperature thermistor, fin temperature thermistor, defrost thermistor, P.C. board temperature thermistor, outdoor heat exchanger temperature thermistor or ambient temperature thermistor shorts or opens during compressor running.	•Refer to 10-5.Ⓒ "Check of outdoor thermistors".	
3			Outdoor control system	Nonvolatile memory data cannot be read properly. (The upper lamp of the OPERATION INDICATOR lamp on the indoor unit lights up or blinks 7-time.)	•Replace inverter P.C. board.	
4			6-time blink 2.5 seconds OFF	Serial signal	The communication fails between the indoor and outdoor unit for 3 minutes.	•Refer to 10-5.Ⓜ "How to check miswiring and serial signal error."
5			11-time blink 2.5 seconds OFF	Stop valve/ Closed valve	Closed valve is detected by compressor current.	•Check stop valve.
6			16-time blink 2.5 seconds OFF	4-way valve/ Pipe temperature	The 4-way valve does not work properly. The indoor coil thermistor detects an abnormal temperature.	<ul style="list-style-type: none"> <li>•Refer to 10-5.Ⓢ "Check of R.V. coil".</li> <li>•Replace the inverter P.C. board.</li> </ul>
7			17-time blink 2.5 seconds OFF	Outdoor refrigerant system abnormality	A closed valve and air trapped in the refrigerant circuit are detected based on the temperature sensed by the indoor and outdoor thermistors and the current of the compressor.	<ul style="list-style-type: none"> <li>•Check for a gas leak in a connecting piping etc.</li> <li>•Check the stop valve.</li> <li>•Refer to 10-5.Ⓣ "Check of outdoor refrigerant circuit".</li> </ul>
8	'Outdoor unit stops and restarts 3 minutes later' is repeated.	2-time blink 2.5 seconds OFF	Overcurrent protection	Large current flows into the power module (IC700) ※ When overcurrent protection occurs within 10 seconds after compressor starts, compressor restarts after 15 seconds (MUZ-WR09/12NA).	<ul style="list-style-type: none"> <li>•Reconnect connector of compressor.</li> <li>•Refer to 10-5.Ⓐ "How to check inverter/compressor".</li> <li>•Check stop valve.</li> </ul>	
9			3-time blink 2.5 seconds OFF	Discharge temperature overheat protection	Temperature of discharge temperature thermistor exceeds 241°F (116°C), compressor stops. Compressor can restart if discharge temperature thermistor reads 212°F (100°C) or less 3 minutes later.	<ul style="list-style-type: none"> <li>•Check refrigerant circuit and refrigerant amount.</li> <li>•Refer to 10-5.Ⓚ "Check of LEV".</li> </ul>
10			4-time blink 2.5 seconds OFF	Fin temperature / P.C. board temperature thermistor overheat protection	Temperature of the fin temperature thermistor on the heat sink exceeds 167 - 176°F (75 - 80°C) (MUZ-WR09/12NA)/167 - 187°F (75 - 86°C) (MUZ-WR18/24NA) or temperature of P.C. board temperature thermistor on the inverter P.C. board exceeds 158 - 167°F (70 - 75°C) (MUZ-WR09/12NA)/162 - 185°F (72 - 85°C) (MUZ-WR18/24NA).	<ul style="list-style-type: none"> <li>•Check around outdoor unit.</li> <li>•Check outdoor unit air passage.</li> <li>•Refer to 10-5.Ⓛ "Check of outdoor fan motor".</li> </ul>
11			5-time blink 2.5 seconds OFF	High pressure protection	Indoor coil thermistor exceeds 158°F (70°C) in HEAT mode. Defrost thermistor exceeds 158°F (70°C) in COOL mode.	<ul style="list-style-type: none"> <li>•Check refrigerant circuit and refrigerant amount.</li> <li>•Check stop valve.</li> </ul>
12			8-time blink 2.5 seconds OFF	Compressor synchronous abnormality	The waveform of compressor current is distorted.	<ul style="list-style-type: none"> <li>•Reconnect connector of compressor.</li> <li>•Refer to 10-5.Ⓐ "How to check inverter/compressor".</li> </ul>
13			10-time blink 2.5 seconds OFF	Outdoor fan motor	Outdoor fan has stopped 3 times in a row within 30 seconds after outdoor fan start-up.	<ul style="list-style-type: none"> <li>•Refer to 10-5.Ⓛ "Check of outdoor fan motor."</li> <li>•Refer to 10-5.Ⓛ "Check of inverter P.C. board."</li> </ul>
14			12-time blink 2.5 seconds OFF	Each phase current of compressor	Each phase current of compressor cannot be detected normally.	•Refer to 10-5.Ⓐ "How to check inverter/compressor".
15			13-time blink 2.5 seconds OFF	Bus-bar voltage (DC)	Bus-bar voltage of inverter cannot be detected normally.	•Refer to 10-5.Ⓐ "How to check inverter/compressor".

- NOTE:** 1. The location of LED is illustrated at the right figure. Refer to 10-6.1.  
 2. LED is lit during normal operation.  
 3. Blinking patterns of this mode differ from the ones of the failure recall mode.

The blinking frequency shows the number of times the LED blinks after every 2.5-second OFF.  
 (Example) When the blinking frequency is "2".

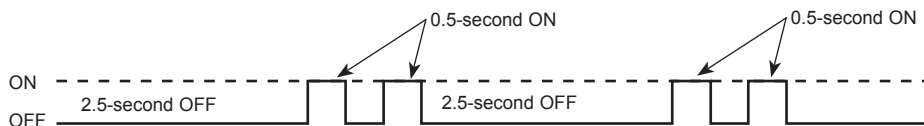

Inverter P.C. board

**MUZ-WR09/12NA**

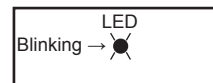

**MUZ-WR18/24NA**

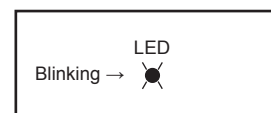



No.	Symptom	LED indication	Abnormal point/Condition	Condition	Remedy	
16	Outdoor unit operates.	1-time blink 2.5 seconds OFF	Frequency drop by current protection	Current from power outlet is nearing Max. fuse size.	The unit is normal, but check the following. •Check if indoor filters are clogged. •Check if refrigerant is short. •Check if indoor/outdoor unit air circulation is short cycled.	
17		3-time blink 2.5 seconds OFF	Frequency drop by high pressure protection	Temperature of indoor coil thermistor exceeds 131 °F (55°C) in HEAT mode, compressor frequency lowers.		
			Frequency drop by defrosting in COOL mode	Indoor coil thermistor reads 46°F (8°C) or less in COOL mode, compressor frequency lowers.		
18		4-time blink 2.5 seconds OFF	Frequency drop by discharge temperature protection	Temperature of discharge temperature thermistor exceeds 232°F (111°C), compressor frequency lowers.	•Check refrigerant circuit and refrigerant amount. •Refer to 10-5.Ⓢ "Check of LEV". •Refer to 10-5.Ⓢ "Check of outdoor thermistors".	
19		5-time blink 2.5 seconds OFF	Outside temperature thermistor protection	When the outside temperature thermistor shorts or opens, protective operation without that thermistor is performed.		•Refer to 10-5. Ⓢ Check of outdoor thermistors.
20		7-time blink 2.5 seconds OFF	Low discharge temperature protection	Temperature of discharge temperature thermistor has been 122°F (50°C) or less for 20 minutes.		•Refer to 10-5.Ⓢ "Check of LEV". •Check refrigerant circuit and refrigerant amount.
21		8-time blink 2.5 seconds OFF	PAM protection PAM: Pulse Amplitude Modulation	The overcurrent flows into PFC (Power factor correction: IC820) or the Bus-bar voltage reaches 394 V or more, PAM stops and restarts.	This is not malfunction. PAM protection will be activated in the following cases: 1 Instantaneous power voltage drop. (Short time power failure) 2 When the power supply voltage is high.	
	Zero cross detecting circuit (MUZ-WR09/12NA)			Zero cross signal for PAM control cannot be detected.		
22	9-time blink 2.5 seconds OFF	Inverter check mode	The connector of compressor is disconnected, inverter check mode starts.	•Check if the connector of the compressor is correctly connected. Refer to 10-5.Ⓢ "How to check inverter/compressor".		

- NOTE:** 1. The location of LED is illustrated at the right figure. Refer to 10-6.1.  
 2. LED is lit during normal operation.  
 3. Blinking patterns of this mode differ from the ones of the failure recall mode.

The blinking frequency shows the number of times the LED blinks after every 2.5-second OFF.  
 (Example) When the blinking frequency is "2".

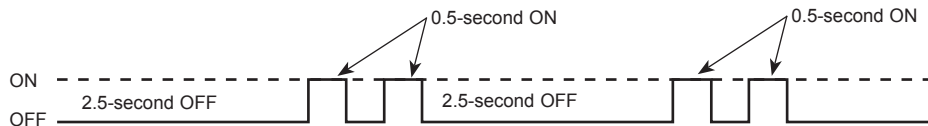

Inverter P.C. board

**MUZ-WR09/12NA**

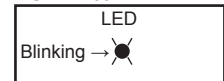

**MUZ-WR18/24NA**

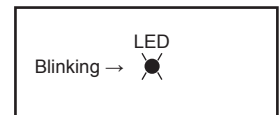

### 10-4. TROUBLE CRITERION OF MAIN PARTS

#### MUZ-WR09NA MUZ-WR12NA MUZ-WR18NA MUZ-WR24NA

Part name	Check method and criterion	Figure													
Defrost thermistor (RT61) Fin temperature thermistor (RT64) Ambient temperature thermistor (RT65) Outdoor heat exchanger temperature thermistor (RT68)	Measure the resistance with a tester.  Refer to 10-6. "Test point diagram and voltage", 1. "Inverter P.C. board", for the chart of thermistor.														
Discharge temperature thermistor (RT62)	Measure the resistance with a tester. Before measurement, hold the thermistor with your hands to warm it up.  Refer to 10-6. "Test point diagram and voltage", 1. "Inverter P.C. board", for the chart of thermistor.														
Compressor	Measure the resistance between terminals using a tester. [Temperature: 14 - 104°F (-10 - 40°C)] <table border="1" style="width: 100%; text-align: center;"> <thead> <tr> <th rowspan="2"></th> <th colspan="3">Normal (Ω)</th> </tr> <tr> <th>WR09/12NA- U1</th> <th>WR09/12NA- U2</th> <th>WR18/24</th> </tr> </thead> <tbody> <tr> <td>U-V</td> <td rowspan="3">1.26 - 1.72</td> <td rowspan="3">1.59 - 2.16</td> <td rowspan="3">0.82 - 1.11</td> </tr> <tr> <td>U-W</td> </tr> <tr> <td>V-W</td> </tr> </tbody> </table>		Normal (Ω)			WR09/12NA- U1	WR09/12NA- U2	WR18/24	U-V	1.26 - 1.72	1.59 - 2.16	0.82 - 1.11	U-W	V-W	
	Normal (Ω)														
	WR09/12NA- U1	WR09/12NA- U2	WR18/24												
U-V	1.26 - 1.72	1.59 - 2.16	0.82 - 1.11												
U-W															
V-W															
Outdoor fan motor	Measure the resistance between lead wires using a tester. [Temperature: 14 - 104°F (-10 - 40°C)] <table border="1" style="width: 100%; text-align: center;"> <thead> <tr> <th rowspan="2">Color of lead wire</th> <th colspan="3">Normal (Ω)</th> </tr> <tr> <th>WR09/12/18NA- U1</th> <th>WR09/12/18NA- U2</th> <th>WR24</th> </tr> </thead> <tbody> <tr> <td>RED - BLK</td> <td rowspan="3">29 - 40</td> <td rowspan="3">28 - 39</td> <td rowspan="3">12 - 16</td> </tr> <tr> <td>BLK - WHT</td> </tr> <tr> <td>WHT - RED</td> </tr> </tbody> </table>	Color of lead wire	Normal (Ω)			WR09/12/18NA- U1	WR09/12/18NA- U2	WR24	RED - BLK	29 - 40	28 - 39	12 - 16	BLK - WHT	WHT - RED	
Color of lead wire	Normal (Ω)														
	WR09/12/18NA- U1	WR09/12/18NA- U2	WR24												
RED - BLK	29 - 40	28 - 39	12 - 16												
BLK - WHT															
WHT - RED															
R. V. coil (21S4)	Measure the resistance using a tester. [Temperature: 14 - 104°F (-10 - 40°C)] <table border="1" style="width: 100%; text-align: center;"> <thead> <tr> <th colspan="2">Normal (kΩ)</th> </tr> <tr> <th>WR09/12/18/24NA- U1, WR18NA- U2</th> <th>WR09/12NA- U2</th> </tr> </thead> <tbody> <tr> <td>0.97 - 1.38</td> <td>1.65 - 2.48</td> </tr> </tbody> </table>	Normal (kΩ)		WR09/12/18/24NA- U1, WR18NA- U2	WR09/12NA- U2	0.97 - 1.38	1.65 - 2.48								
Normal (kΩ)															
WR09/12/18/24NA- U1, WR18NA- U2	WR09/12NA- U2														
0.97 - 1.38	1.65 - 2.48														
Expansion valve coil (LEV)	Measure the resistance using a tester. [Temperature: 14 - 104°F (-10 - 40°C)] <table border="1" style="width: 100%; text-align: center;"> <thead> <tr> <th>Color of lead wire</th> <th>Normal (Ω)</th> </tr> </thead> <tbody> <tr> <td>RED - ORN</td> <td rowspan="4">37 - 54</td> </tr> <tr> <td>RED - WHT</td> </tr> <tr> <td>RED - BLU</td> </tr> <tr> <td>RED - YLW</td> </tr> </tbody> </table>	Color of lead wire	Normal (Ω)	RED - ORN	37 - 54	RED - WHT	RED - BLU	RED - YLW							
Color of lead wire	Normal (Ω)														
RED - ORN	37 - 54														
RED - WHT															
RED - BLU															
RED - YLW															
Defrost heater (Optional parts)	Measure the resistance using a tester. [Temperature: 14 - 104°F (-10 - 40°C)] <table border="1" style="width: 100%; text-align: center;"> <thead> <tr> <th colspan="2">Normal (Ω)</th> </tr> <tr> <th>WR09/12/18</th> <th>WR24</th> </tr> </thead> <tbody> <tr> <td>349 - 428</td> <td>376 - 461</td> </tr> </tbody> </table>	Normal (Ω)		WR09/12/18	WR24	349 - 428	376 - 461								
Normal (Ω)															
WR09/12/18	WR24														
349 - 428	376 - 461														

## 10-5. TROUBLESHOOTING FLOW

### A How to check inverter/compressor

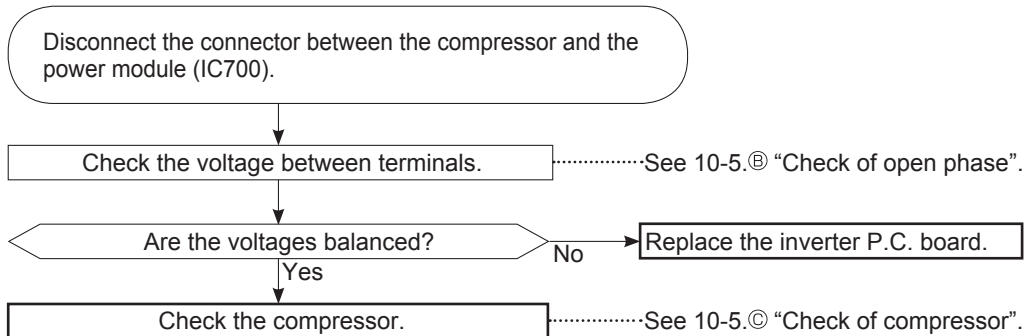

### B Check of open phase

- With the connector between the compressor and the power module (IC700) inverter and check if the inverter is normal by measuring **the voltage balance** between the terminals.

Output voltage is 50 - 130 V. (The voltage may differ according to the tester.)

<< Operation method >>

Start cooling or heating operation by pressing EMERGENCY OPERATION switch on the indoor unit. (TEST RUN OPERATION: Refer to 7-6.)

<< Measurement point >>

At 3 points

BLK (U)-WHT (V)

BLK (U)-RED (W)

WHT(V)-RED (W)

※ Measure AC voltage between the lead wires at 3 points.

**NOTE:** 1. Output voltage varies according to power supply voltage.

2. Measure the voltage by analog type tester.

3. During this check, LED of the inverter P.C. board blinks 9 times. (Refer to 10-6.1.)

### C Check of compressor

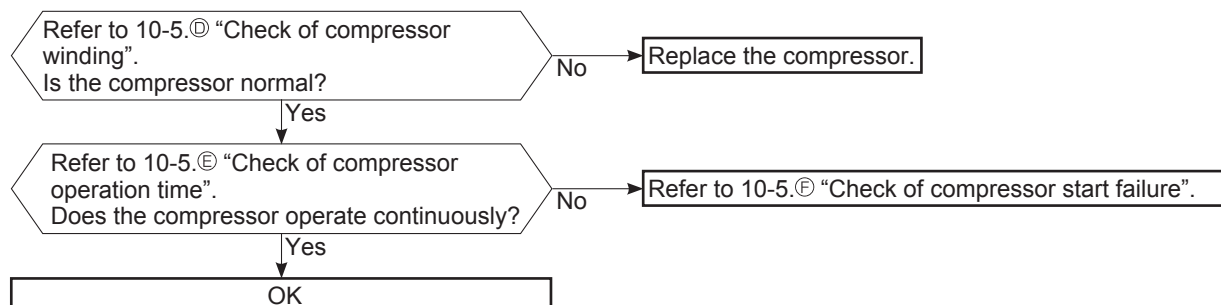

### D Check of compressor winding

• Disconnect the connector between the compressor and the power module (IC700), and measure the resistance between the compressor terminals.

<<Measurement point>>

At 3 points

BLK-WHT

BLK-RED

WHT-RED

※ Measure the resistance between the lead wires at 3 points.

<<Judgement>>

Refer to 10-4.

0 [Ω] .....Abnormal [short]

Infinite [Ω] .....Abnormal [open]

**NOTE:** Be sure to zero the ohmmeter before measurement.

### E Check of compressor operation time

• Connect the compressor and activate the inverter. Then measure the time until the inverter stops due to overcurrent.

<<Operation method>>

Start heating or cooling operation by pressing EMERGENCY OPERATION switch on the indoor unit. (TEST RUN OPERATION: Refer to 7-6.)

<<Measurement>>

Measure the time from the start of compressor to the stop of compressor due to overcurrent.

<<Judgement>>

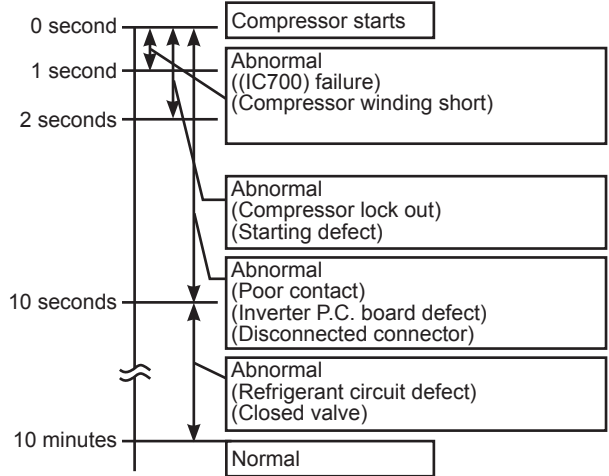

### F Check of compressor start failure

Confirm that ①~④ is normal.

• Electrical circuit check

①. Contact of the compressor connector

②. Output voltage of inverter P.C. board and balance of them (See 10-5.⑥)

③. Direct current voltage between DB61(+) and (-) on the inverter P.C. board

④. Voltage between outdoor terminal block S1-S2

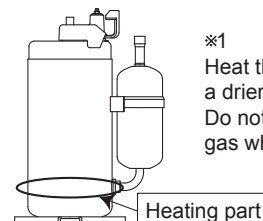
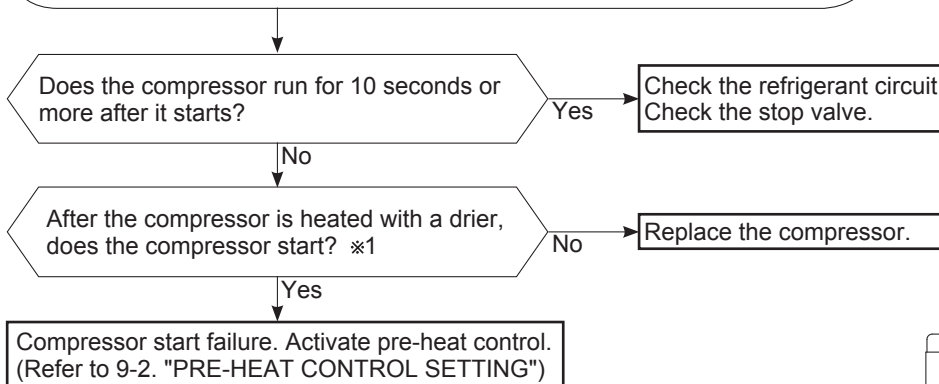

※1  
Heat the compressor with a drier for about 20 minutes. Do not recover refrigerant gas while heating.

## G Check of outdoor thermistors

Disconnect the connector of thermistor in the inverter P.C. board (see below table), and measure the resistance of thermistor.

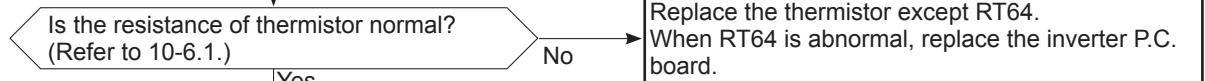

Yes  
Reconnect the connector of thermistor.  
Turn ON the power supply and press EMERGENCY OPERATION switch.

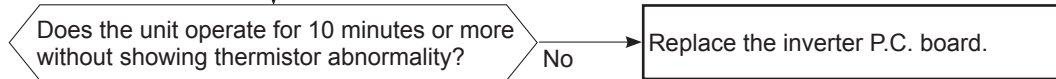

Yes  
OK  
(Cause is poor contact.)

Thermistor	Symbol	Connector, Pin No.	Board
Defrost	RT61	Between CN641 pin1 and pin2	Inverter P.C. board
Discharge temperature	RT62	Between CN641 pin3 and pin4	
Fin temperature	RT64	Between CN642 pin1 and pin2	
Ambient temperature	RT65	Between CN643 pin1 and pin2	
Outdoor heat exchanger temperature	RT68	Between CN644 pin1 and pin3	

## H Check of R.V. coil

- ※ First of all, measure the resistance of R.V. coil to check if the coil is defective. Refer to 10-4.
- ※ Check if there is 208/230 V AC at L1 - L2.
- ※ In case CN721 is disconnected or R.V. coil is open, voltage is generated between the terminal pins of the connector although no signal is being transmitted to R.V. coil.  
Check if CN721 is connected.

### Unit operates in COOL mode even if it is set to HEAT mode.

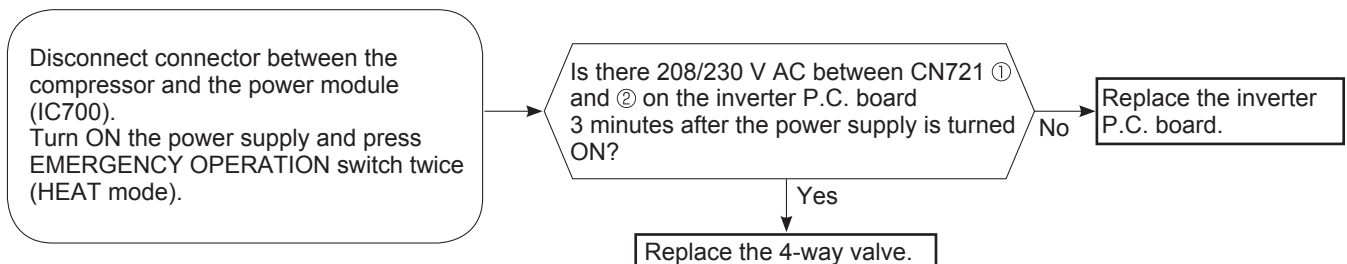

### Unit operates in HEAT mode even if it is set to COOL mode.

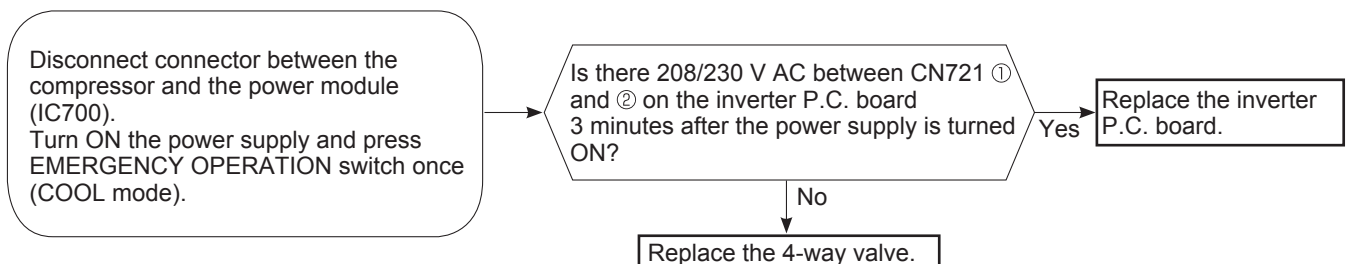

### ① Check of outdoor fan motor

Check the connection between the connector CN931 and CN932.  
Disconnect the connectors CN931 and CN932 from the inverter P.C. board.

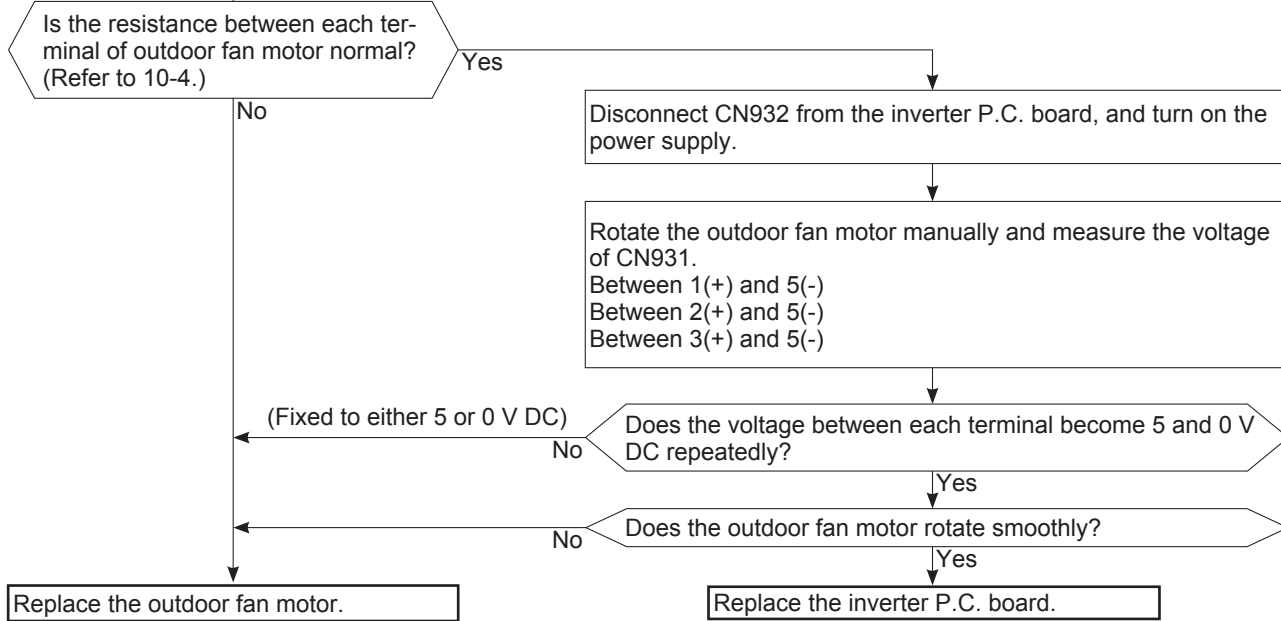

**J Check of power supply**

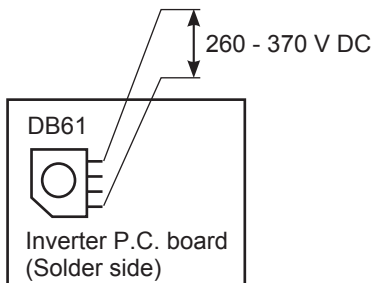
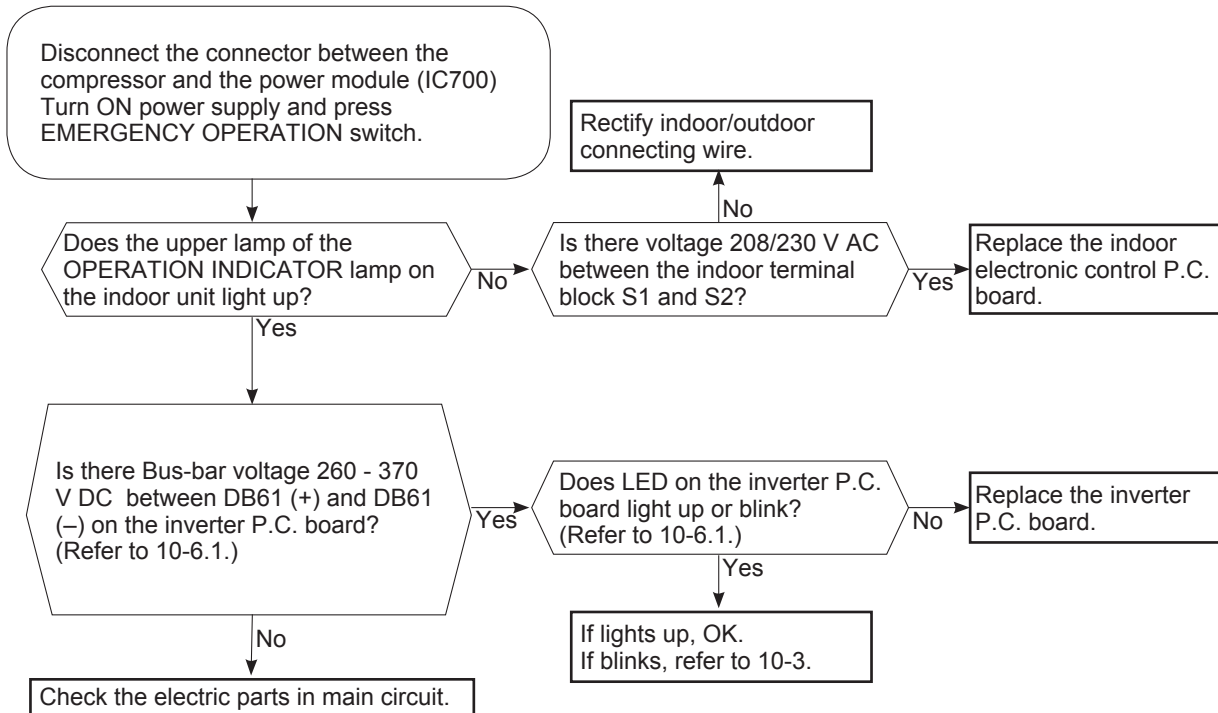

## K Check of LEV (Expansion valve)

Turn ON the power supply.  
 <Preparation of the remote controller>  
 ① While pressing both OPERATION SELECT button and TOO COOL button on the remote controller at the same time, press RESET button.  
 ② First, release RESET button.  
 Hold down the other 2 buttons for another 3 seconds.  
 Make sure that the indicators on the LCD screen shown in the right figure are all displayed. Then release the buttons.

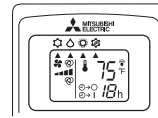
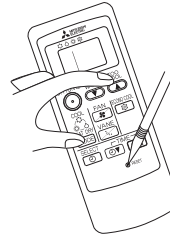

Press STOP/OPERATE (OFF/ON) button of the remote controller (the set temperature is displayed) with the remote controller headed towards the indoor unit. ※1

Expansion valve operates in full-opening direction.

Do you hear the expansion valve "click, click....." ?  
 Do you feel the expansion valve vibrate when touching it ?

Yes → OK

No

Is LEV coil properly fixed to the expansion valve?

No

Properly fix the LEV coil to the expansion valve.

Yes

Does the resistance of LEV coil have the characteristics? (Refer to 10-4.)

Yes

Measure each voltage between connector pins of CN724 on the inverter P.C. board.  
 1. Pin③(-) — Pin①(+)  
 2. Pin④(-) — Pin①(+)  
 3. Pin⑤(-) — Pin①(+)  
 4. Pin⑥(-) — Pin①(+)  
 Is there about 3 - 5 V AC between each?  
**NOTE:** Measure the voltage by an analog tester.

No

Replace the inverter P.C. board.

Replace the LEV coil.

Yes

Replace the expansion valve.

※1. Regardless of normal or abnormal condition, a short beep is emitted once the signal is received.

**NOTE:** After check of LEV, take the following steps.

1. Turn OFF the power supply and turn it ON again.
2. Press RESET button on the remote controller.

**L Check of inverter P.C. board**

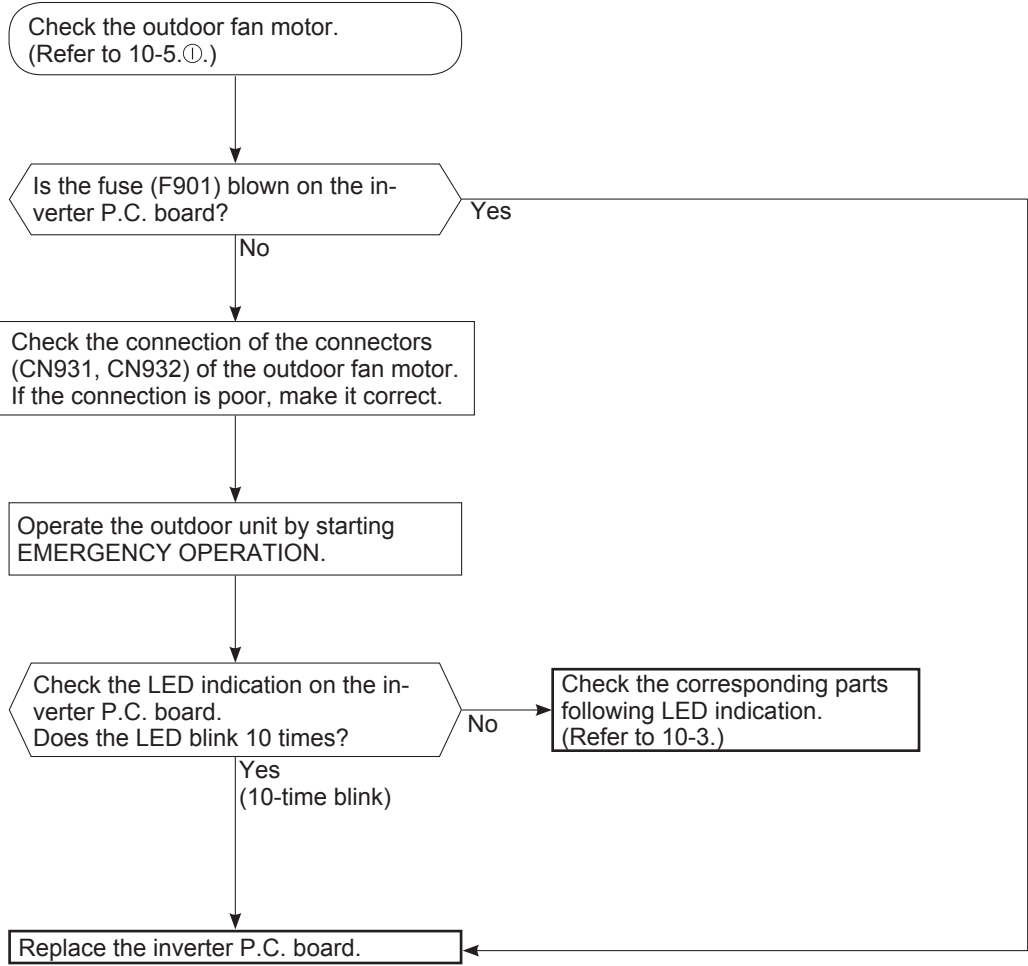

## M How to check miswiring and serial signal error

MUZ-WR09/12NA

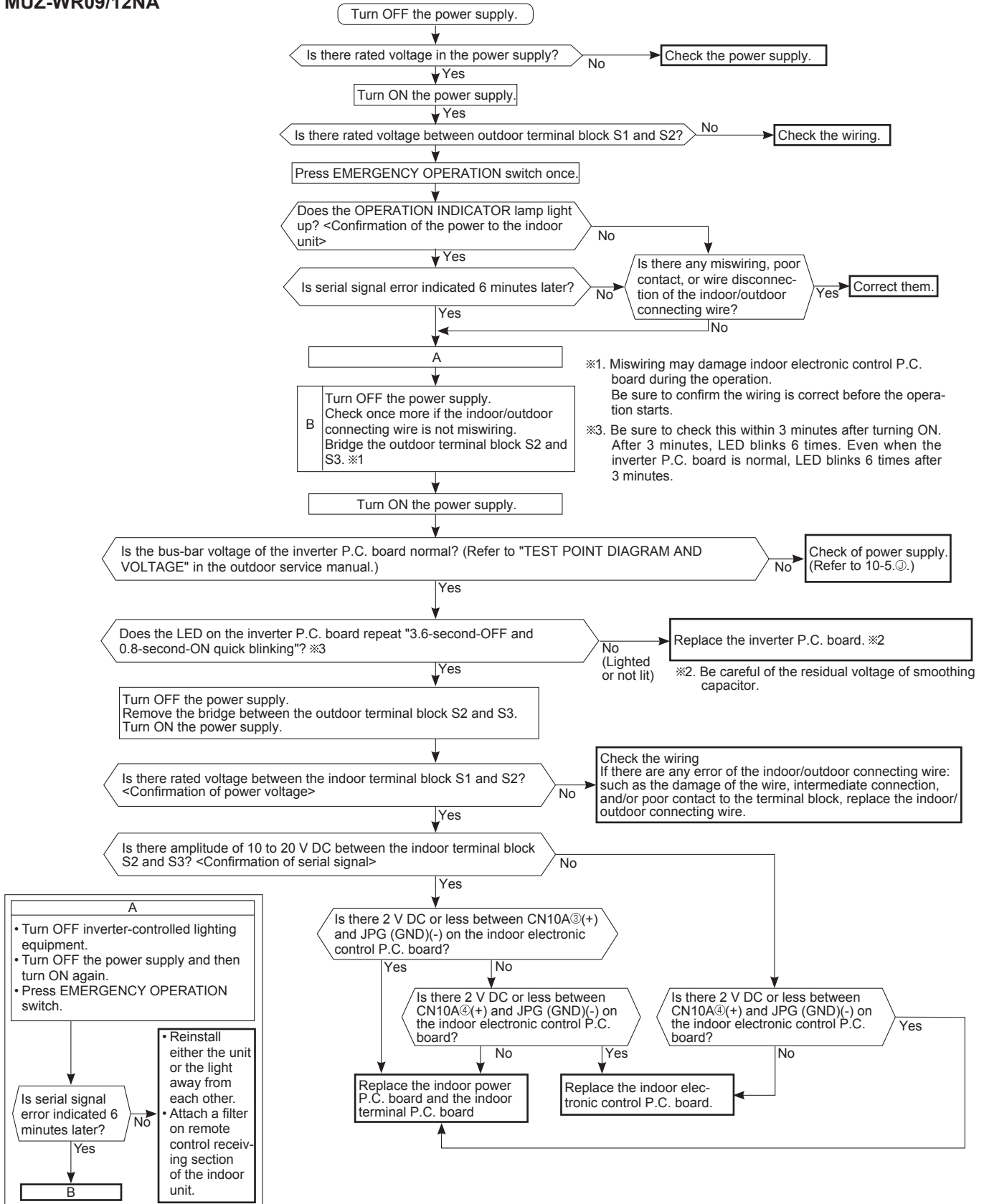

MUZ-WR18/24NA

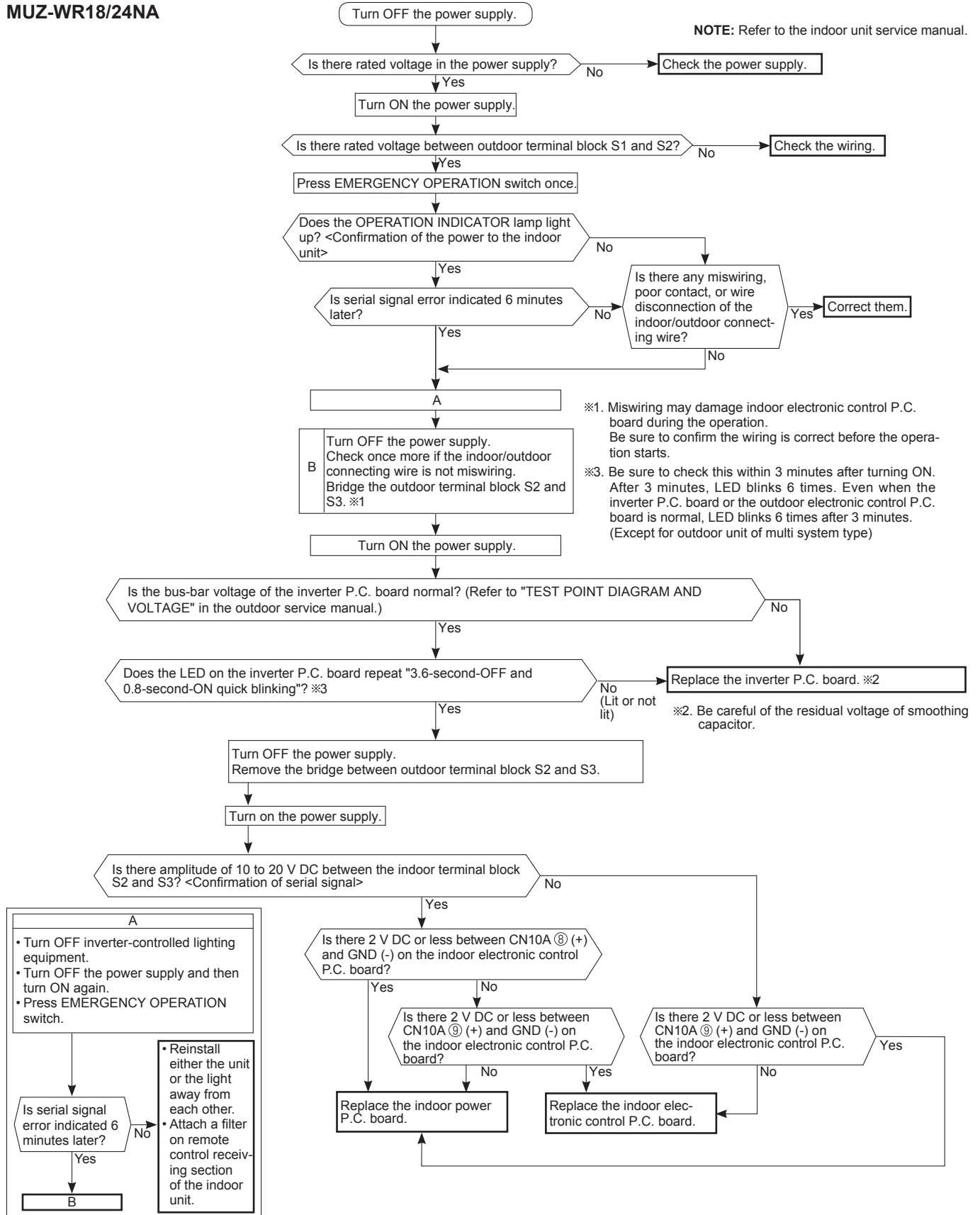

## N Check of defrost heater

(Optional parts)

Check the following points before checking electric continuity.

1. Does the resistance of ambient temperature thermistor have the characteristics? Refer to 10-6.1.
2. Is the resistance of defrost heater normal? Refer to 10-4.
3. Does the heater protector remain conducted (not open)?
4. Are both ambient temperature thermistor and circuit of defrost heater securely connected to connectors?

In HEAT mode, for more than 5 minutes, let the ambient temperature thermistor continue to read 32°F (0°C) or below, and let the defrost thermistor continue to read 30°F (-1°C) or below.

**NOTE:** In case both thermistors are more than the above temperature, cool them with cold water etc.

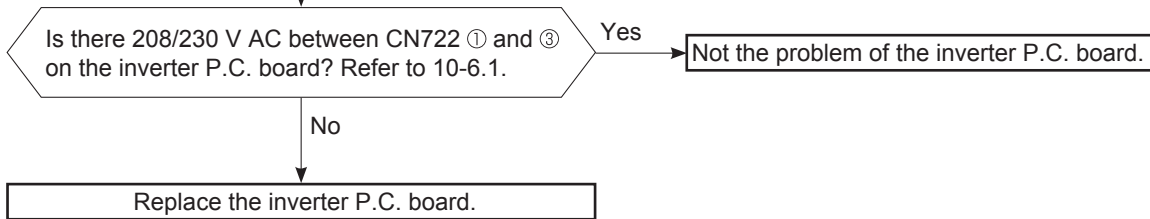

## O Check of outdoor refrigerant circuit

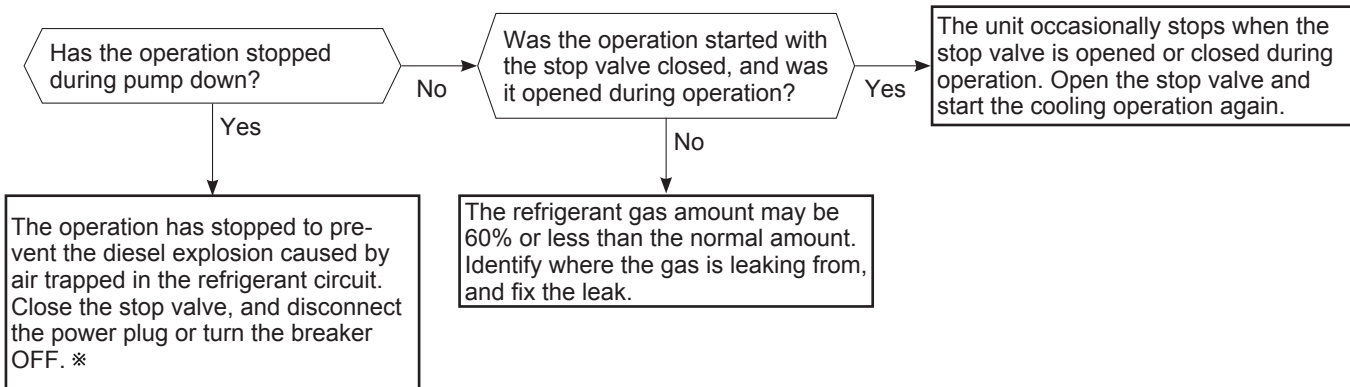

\* **CAUTION** : Do not start the operation again to prevent hazards.

**P Electromagnetic noise enters into TV sets or radios**

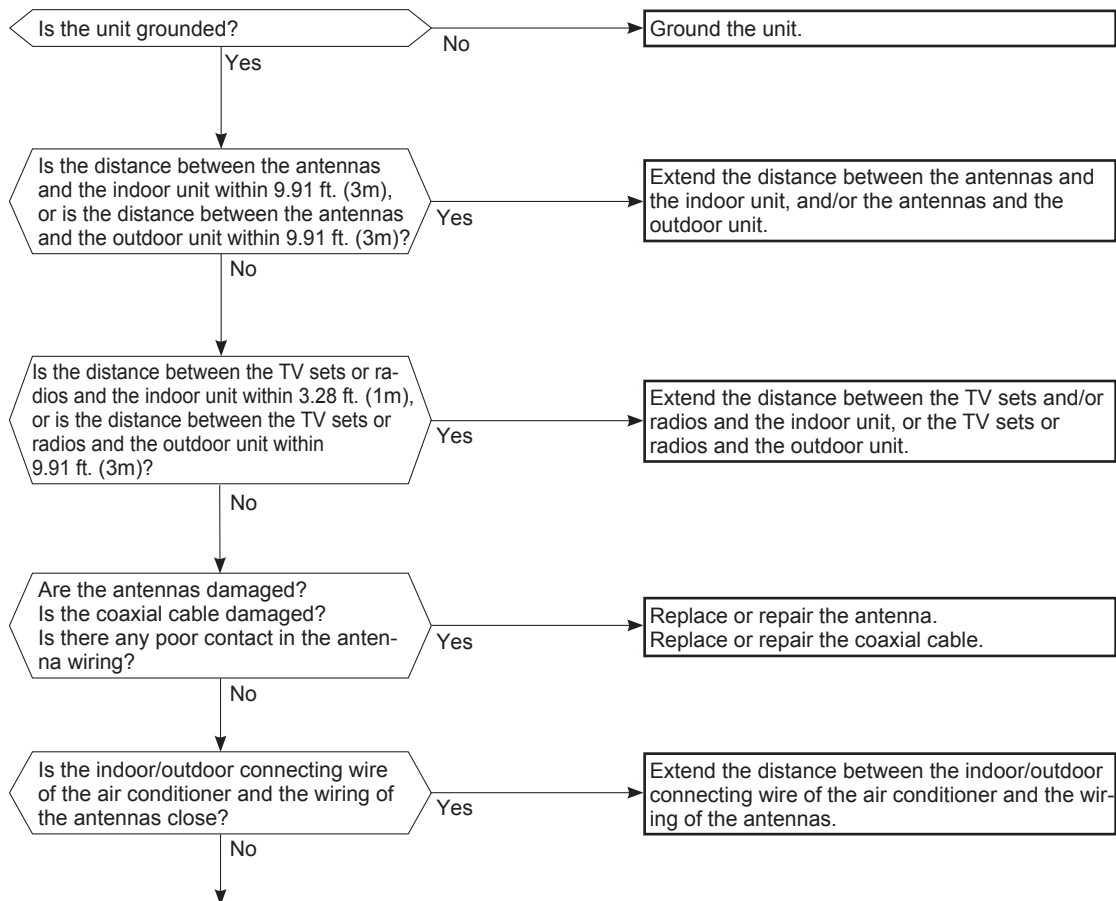

Even if all of the above conditions are fulfilled, the electromagnetic noise may enter, depending on the electric field strength or the installation condition (combination of specific conditions such as antennas or wiring).  
Check the following before asking for service.

1. Devices affected by the electromagnetic noise  
TV sets, radios (FM/AM broadcast, shortwave)
2. Channel, frequency, broadcast station affected by the electromagnetic noise
3. Channel, frequency, broadcast station unaffected by the electromagnetic noise
4. Layout of:  
indoor/outdoor unit of the air conditioner, indoor/outdoor wiring, ground wire, antennas, wiring from antennas, receiver
5. Electric field intensity of the broadcast station affected by the electromagnetic noise
6. Presence or absence of amplifier such as booster
7. Operation condition of air conditioner when the electromagnetic noise enters in
  - 1) Turn OFF the power supply once, and then turn ON the power supply. In this situation, check for the electromagnetic noise.
  - 2) Within 3 minutes after turning ON the power supply, press STOP/OPERATE (OFF/ON) button on the remote controller for power ON, and check for the electromagnetic noise.
  - 3) After a short time (3 minutes later after turning ON), the outdoor unit starts running. During operation, check for the electromagnetic noise.
  - 4) Press STOP/OPERATE (OFF/ON) button on the remote controller for power OFF, when the outdoor unit stops but the indoor/outdoor communication still runs on. In this situation, check for the electromagnetic noise.

# 10-6. TEST POINT DIAGRAM AND VOLTAGE

## 1. Inverter P.C. board

MUZ-WR09NA- [U1] MUZ-WR12NA- [U1]

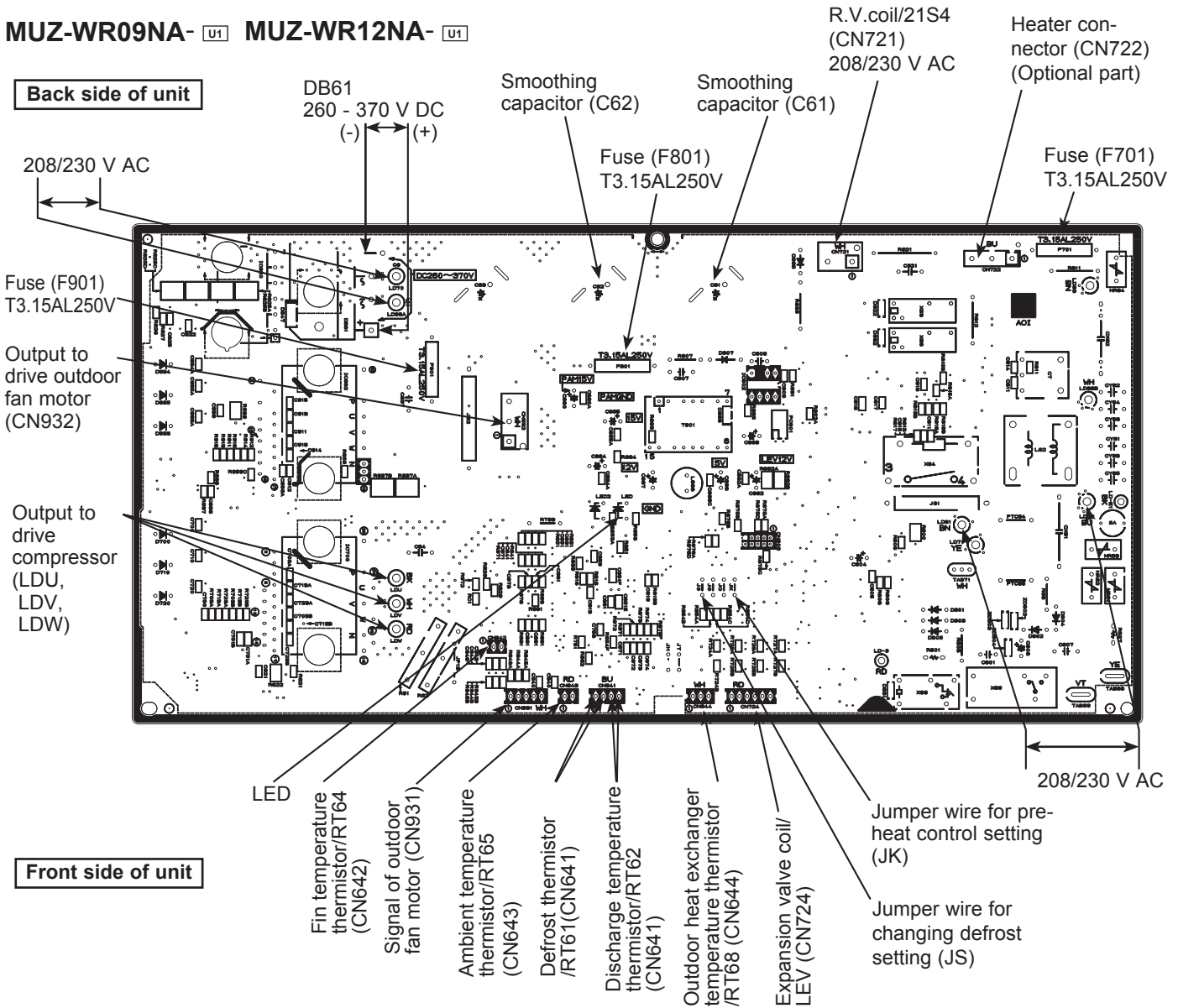

Defrost thermistor(RT61)  
Ambient temperature thermistor(RT65)  
Outdoor heat exchanger temperature thermistor(RT68)

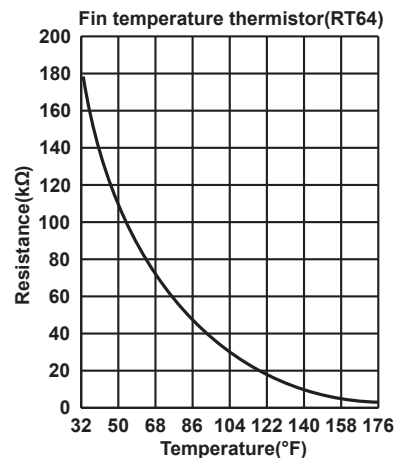
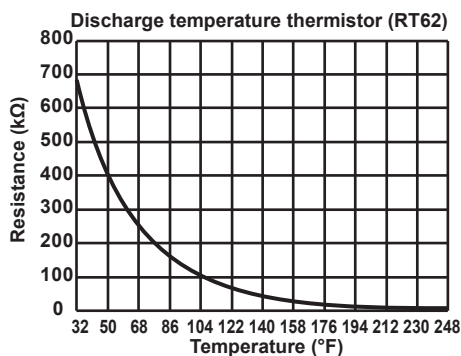
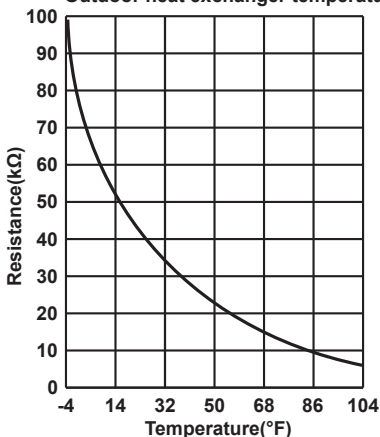

# 1. Inverter P.C. board

## MUZ-WR18NA- U1

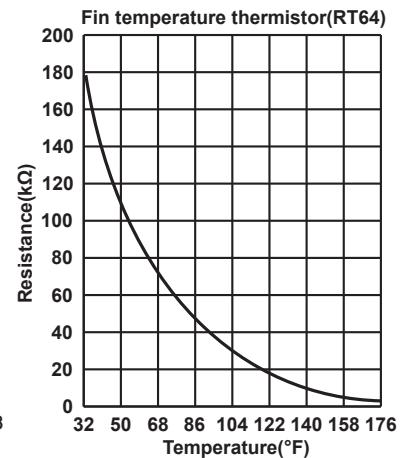
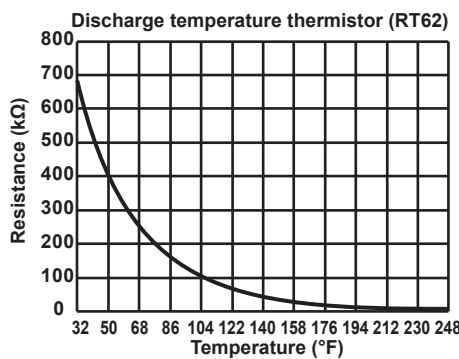
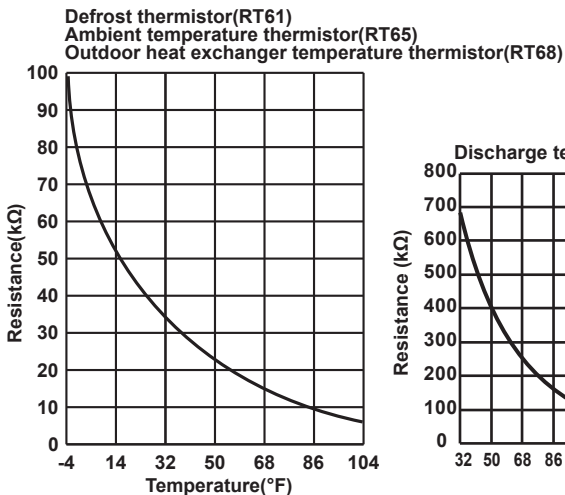
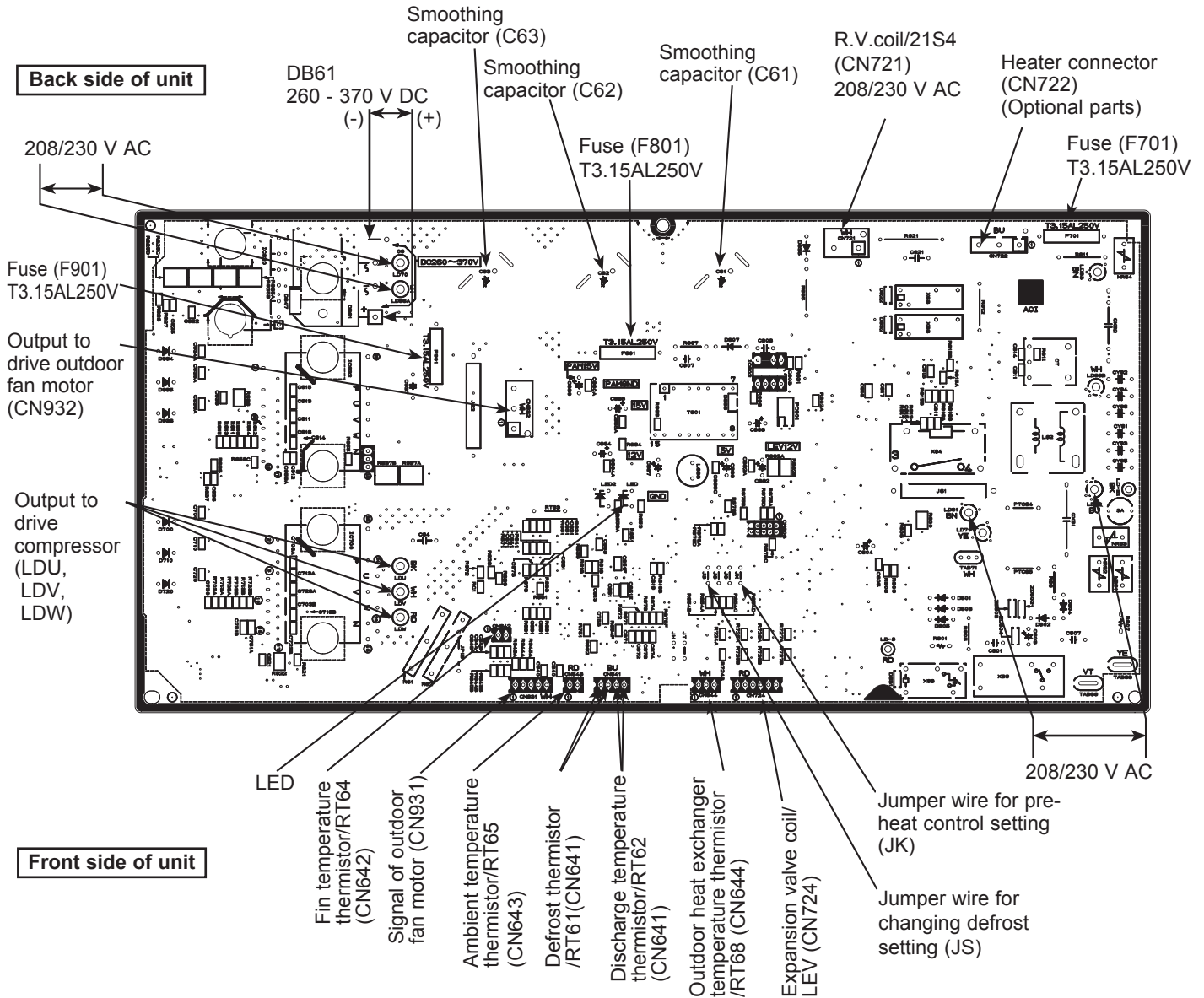

1. Inverter P.C. board

MUZ-WR09NA- U2 MUZ-WR12NA- U2 MUZ-WR18NA- U2

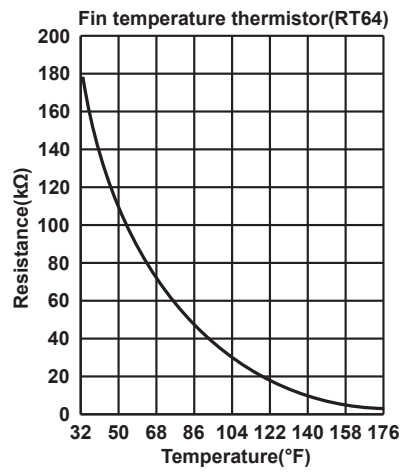
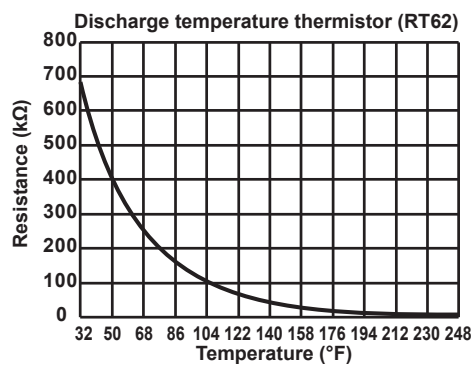
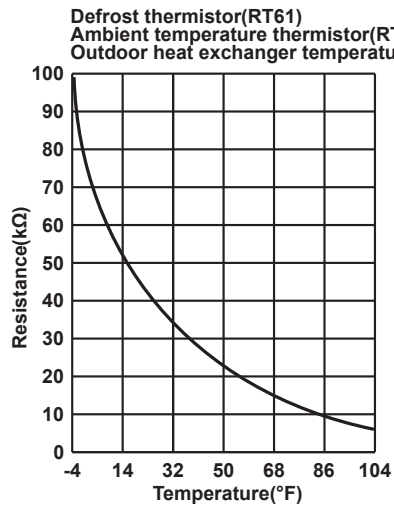
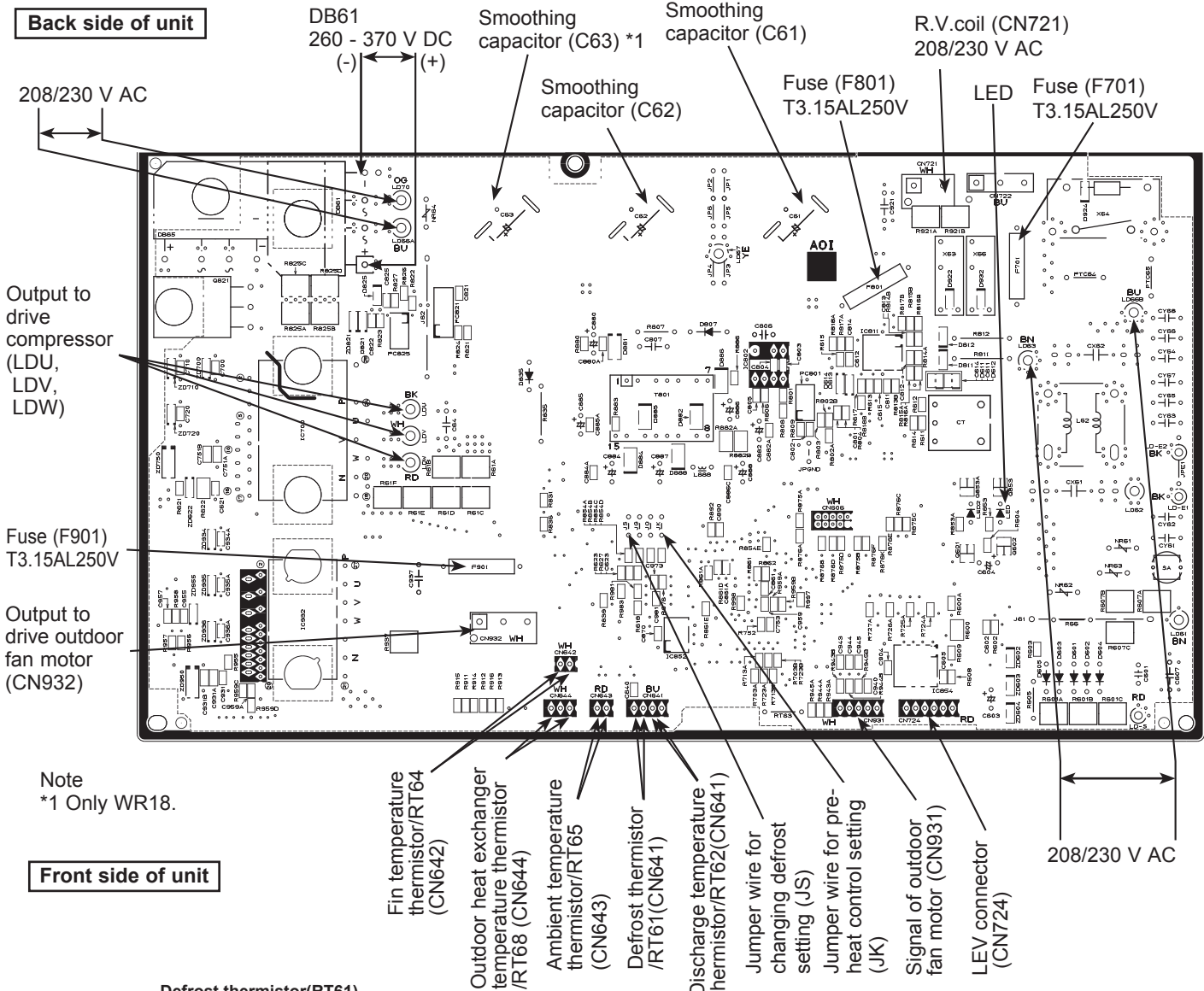

# 1. Inverter P.C. board

## MUZ-WR24NA

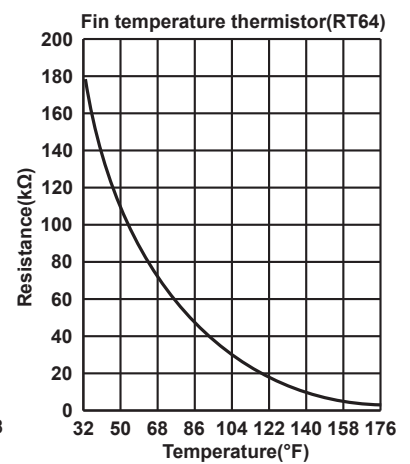
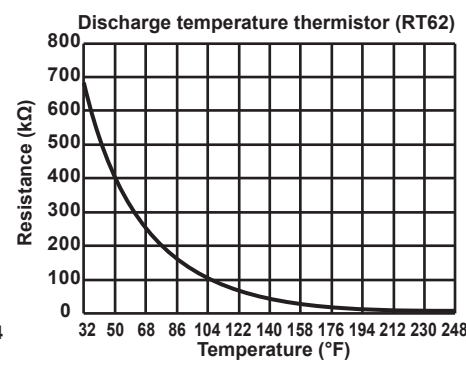
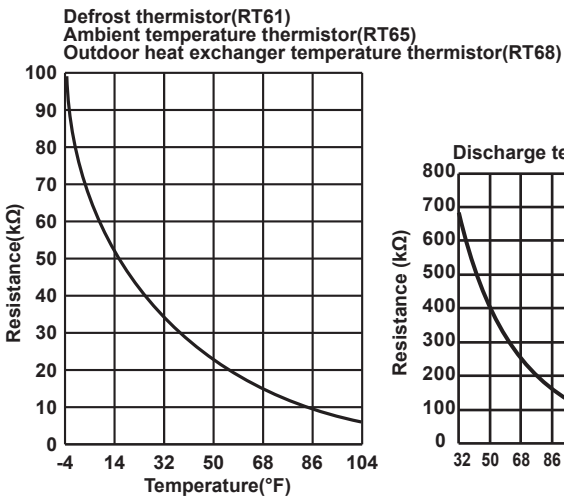
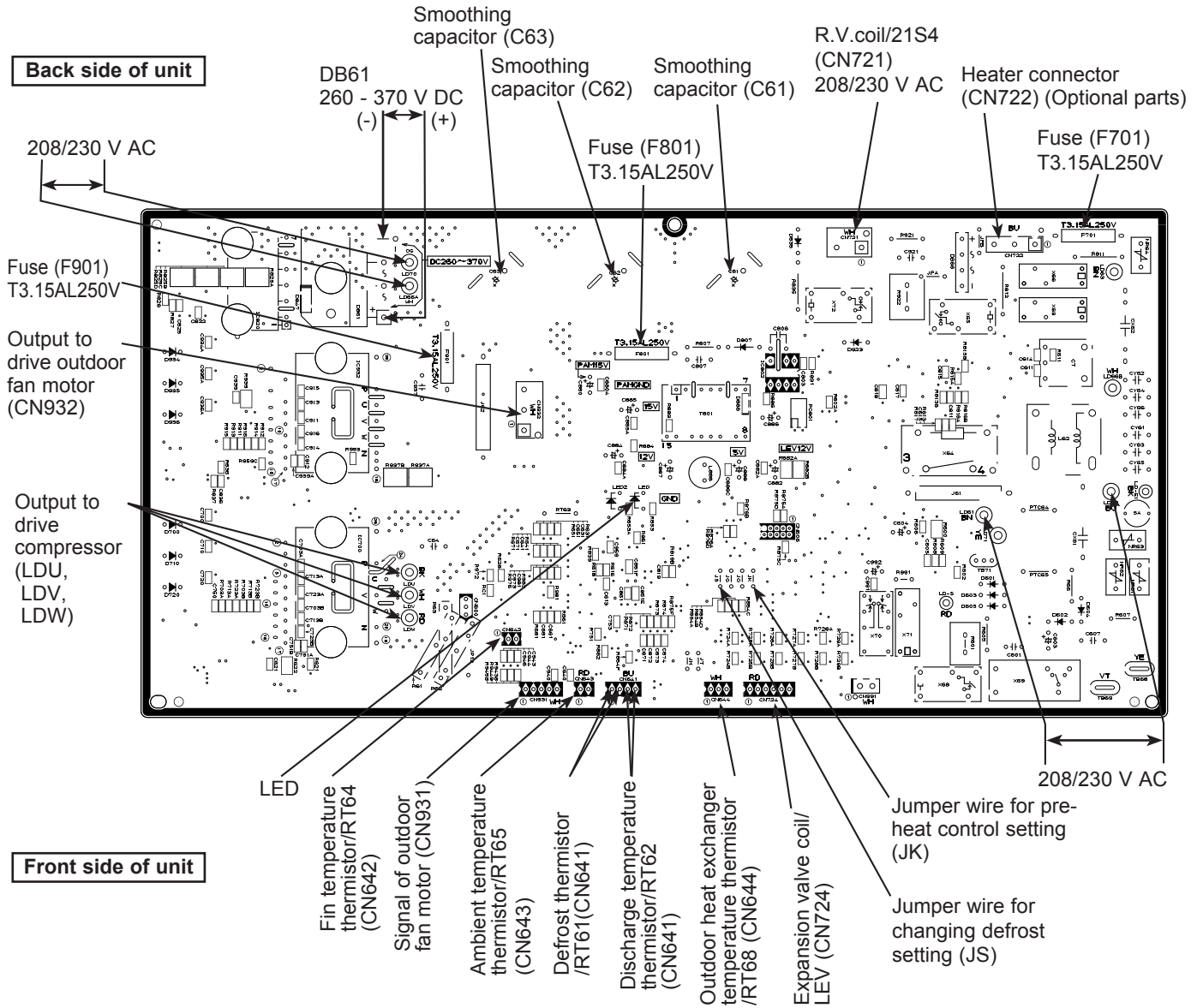

<Detaching method of the terminal with locking mechanism>

The terminal which has the locking mechanism can be detached as shown below.

There are 2 types of terminals with locking mechanism.

The terminal without locking mechanism can be detached by pulling it out.

Check the shape of the terminal before detaching.

(1) Slide the sleeve and check if there is a locking lever or not.

(2) The terminal with this connector shown below has the locking mechanism.

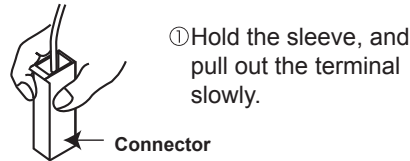
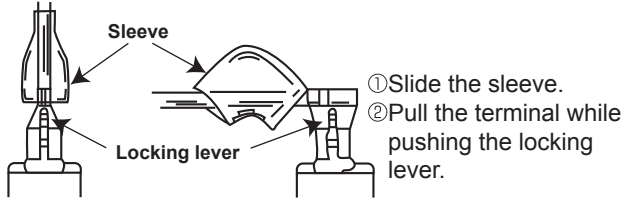

—————: Indicates the visible parts in the photos/figures.  
 - - - - -: Indicates the invisible parts in the photos/figures.

11-1. MUZ-WR09NA MUZ-WR12NA MUZ-WR18NA

NOTE: Turn OFF the power supply before disassembly.

OPERATING PROCEDURE	PHOTOS/FIGURES
<p><b>1. Removing the cabinet</b></p> <ol style="list-style-type: none"> <li>(1) Remove the screw fixing the service panel.</li> <li>(2) Pull down the service panel and remove it.</li> <li>(3) Remove all the screws fixing the conduit cover.</li> <li>(4) Remove the conduit cover. (Photo 4)</li> <li>(5) Remove the screw fixing the conduit plate. (Photo 5)</li> <li>(6) Remove the conduit plate.</li> <li>(7) Disconnect the power supply wire and indoor/outdoor connecting wire.</li> <li>(8) Remove all the screws fixing the top panel.</li> <li>(9) Remove the top panel.</li> <li>(10) Remove all the screws fixing the cabinet.</li> <li>(11) Remove the cabinet.</li> <li>(12) Remove all the screws fixing the back panel.</li> <li>(13) Remove the back panel.</li> </ol> <p><b>Photo 2</b></p>	<p><b>Photo 1</b></p> <p><b>Photo 3</b></p>

## OPERATING PROCEDURE

Photo 4

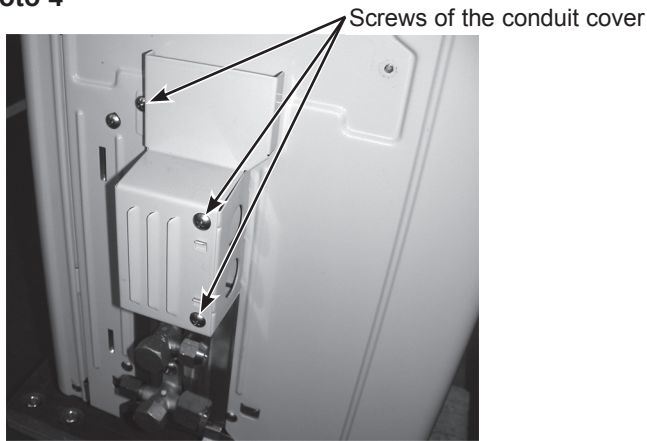

## PHOTOS/FIGURES

Photo 5

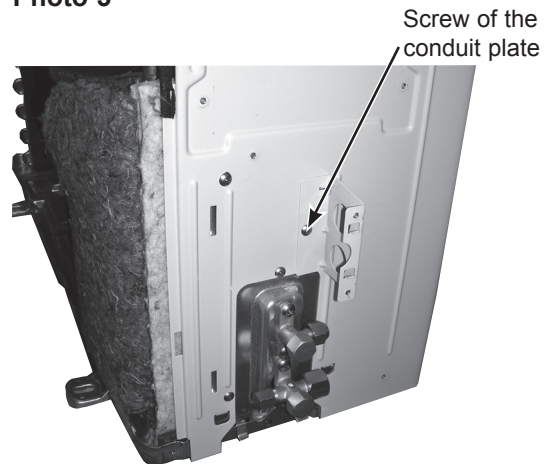

### 2. Removing the inverter assembly, inverter P.C. board

- (1) Remove the cabinet and panels. (Refer to section 1.)
- (2) Disconnect the lead wire to the reactor and the following connectors:  
<Inverter P.C. board>  
CN721 (R.V. coil)  
CN931, CN932 (Fan motor)  
CN641 (Defrost thermistor and discharge temperature thermistor)  
CN643 (Ambient temperature thermistor)  
CN644 (Outdoor heat exchanger temperature thermistor)  
CN724 (LEV)
- (3) Remove the compressor connector (CN61).
- (4) Remove all the screws fixing the heat sink support and the separator.
- (5) Remove the fixing screws of the terminal block support and the back panel.
- (6) Remove the inverter assembly.
- (7) Remove the screw of the ground wire and screw of the terminal block support.
- (8) Remove the heat sink support from the P.C. board support.
- (9) Remove the screw of the inverter P.C. board and remove the inverter P.C. board from the P.C. board support.

Photo 6 MUZ-WR09/12/18NA- U1

Screws of the heat sink support and the separator

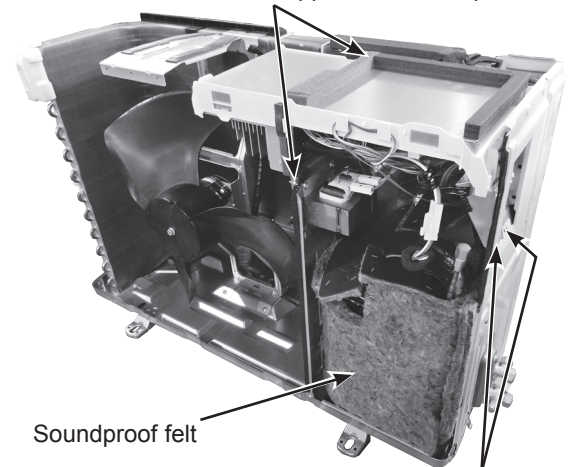

Screws of the terminal block support and the back panel

Photo 7 MUZ-WR09/12/18NA- U2

Screws of the heat sink support and the separator

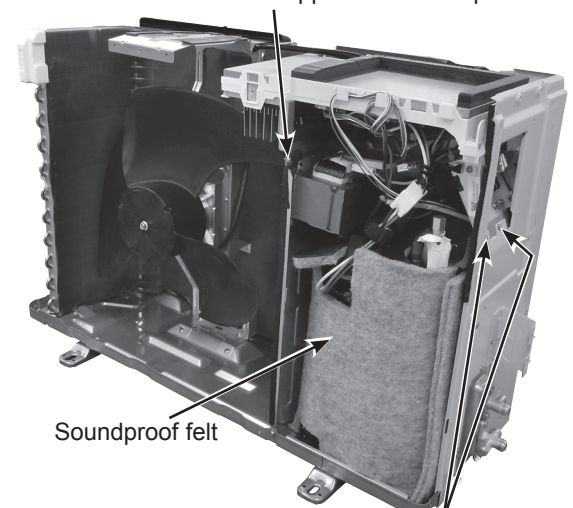

Screws of the terminal block support and the back panel

## OPERATING PROCEDURE

### 3. Removing R.V. coil

- (1) Remove the cabinet and panels. (Refer to section 1.)
- (2) Disconnect the following connectors:  
<Inverter P.C. board>  
CN721 (R.V. coil)
- (3) Remove the R.V. coil.

## PHOTOS/FIGURES

Photo 9 MUZ-WR09/12/18NA- U1

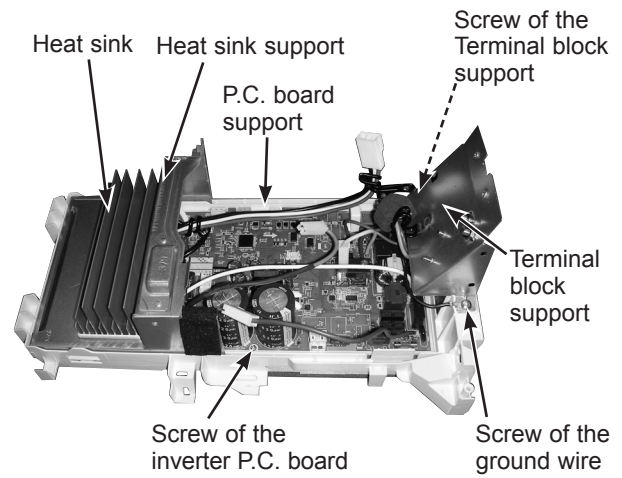
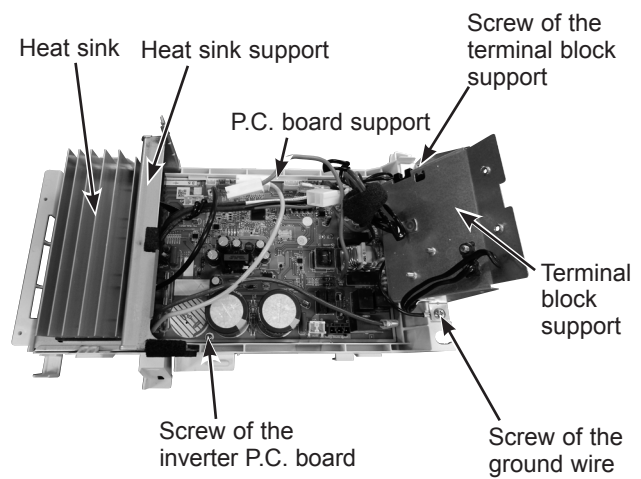

Photo 10 MUZ-WR09/12/18NA- U2



## OPERATING PROCEDURE

### 4. Removing the discharge temperature thermistor, defrost thermistor, outdoor heat exchanger temperature thermistor and ambient temperature thermistor

- (1) Remove the cabinet and panels. (Refer to section 1.)
- (2) Disconnect the lead wire to the reactor and the following connectors:
  - <Inverter P.C. board>
  - CN641 (Defrost thermistor and discharge temperature thermistor)
  - CN643 (Ambient temperature thermistor)
  - CN644 (Outdoor heat exchanger temperature thermistor)
- (3) Pull out the discharge temperature thermistor from its holder.
- (4) Pull out the defrost thermistor from its holder.
- (5) Pull out the outdoor heat exchanger temperature thermistor from its holder.
- (6) Pull out the ambient temperature thermistor from its holder.

Photo 13 MUZ-WR09/12NA- U2

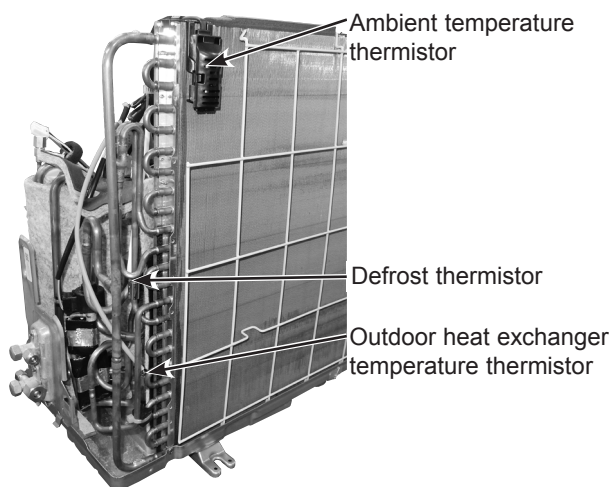

Photo 11

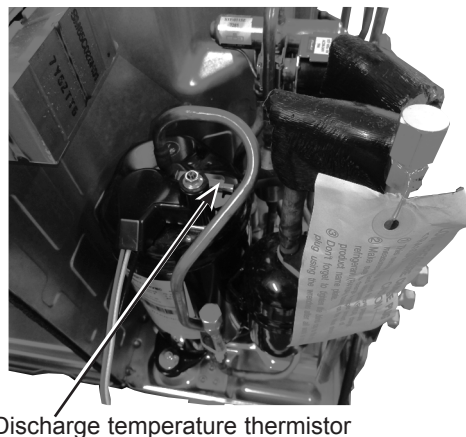

Photo 12 MUZ-WR09/12NA- U1

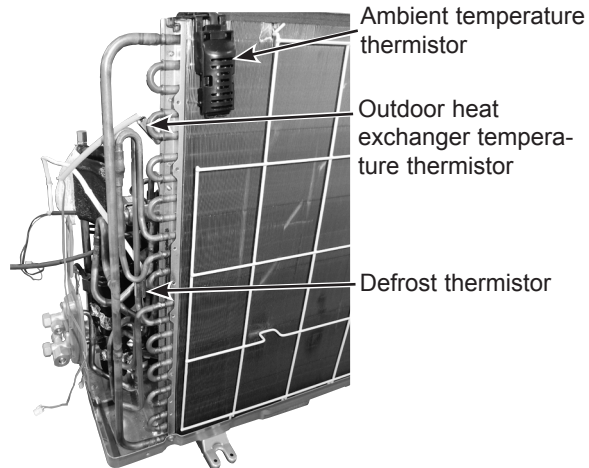
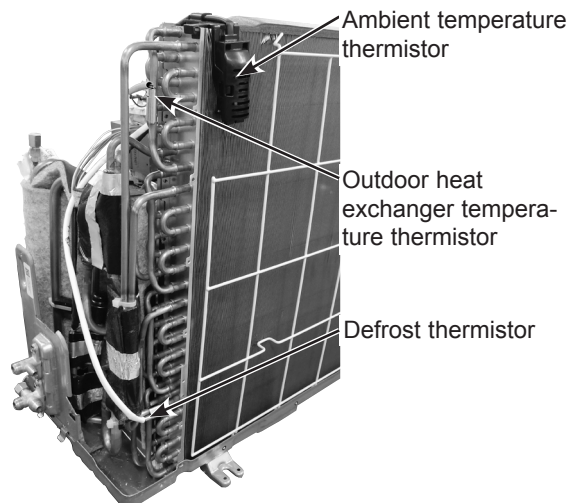

Photo 14 MUZ-WR18NA- U1, U2





OPERATING PROCEDURE	PHOTOS/FIGURES
---------------------	----------------

**5. Removing outdoor fan motor**

- (1) Remove the cabinet and panels. (Refer to section 1.)
  - (2) Disconnect the following connectors:  
<Inverter P.C. board>  
CN931, CN932 (Fan motor)
  - (3) Remove the propeller fan nut.
  - (4) Remove the propeller fan.
  - (5) Remove all the screws fixing the fan motor.
  - (6) Remove the fan motor.
- NOTE:** The propeller fan nut is a reverse thread.

**Photo 15**

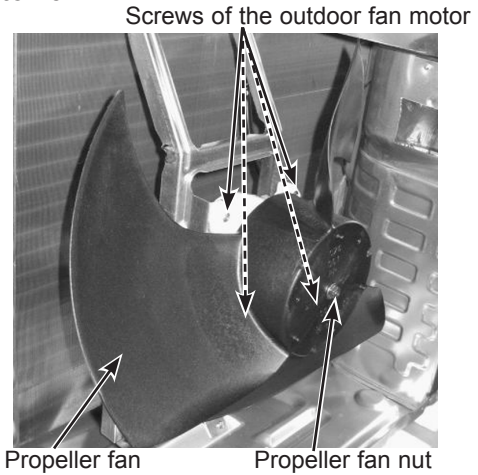

**6. Removing the compressor and 4-way valve**

- (1) Remove the cabinet and panels. (Refer to section 1.)
- (2) Remove the inverter assembly. (Refer to section 2.)
- (3) Remove all the screws fixing the reactor.
- (4) Remove the reactor.
- (5) Remove the soundproof felt.
- (6) Recover gas from the refrigerant circuit.  
**NOTE:** Recover gas from the pipes until the pressure gauge shows 0 PSIG.
- (7) Detach the brazed part of the suction and the discharge pipe connected with compressor.
- (8) Remove the nuts fixing the compressor.
- (9) Remove the compressor.
- (10) Detach the brazed part of pipes connected with 4-way valve.

**Photo 16**

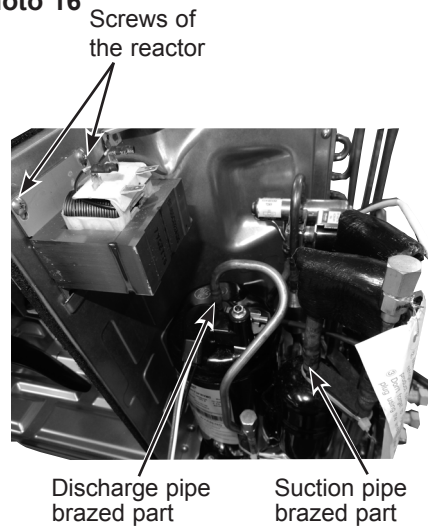

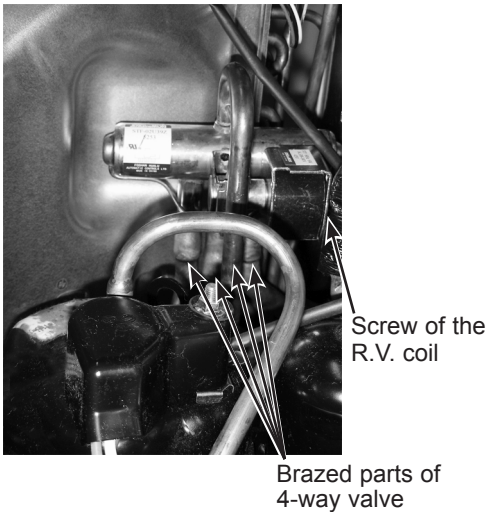
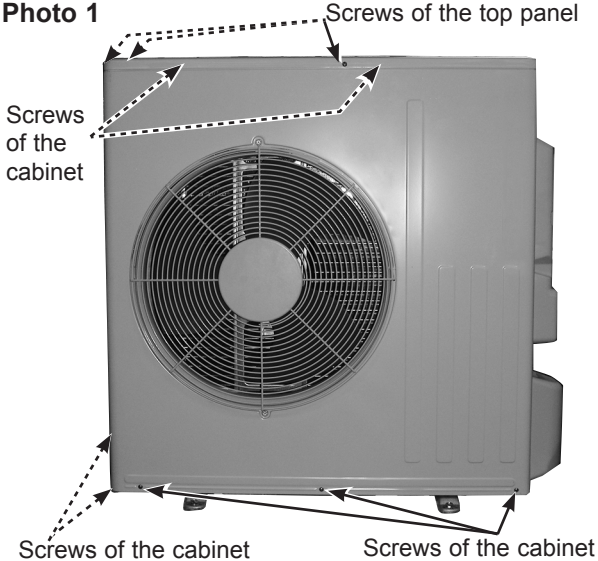
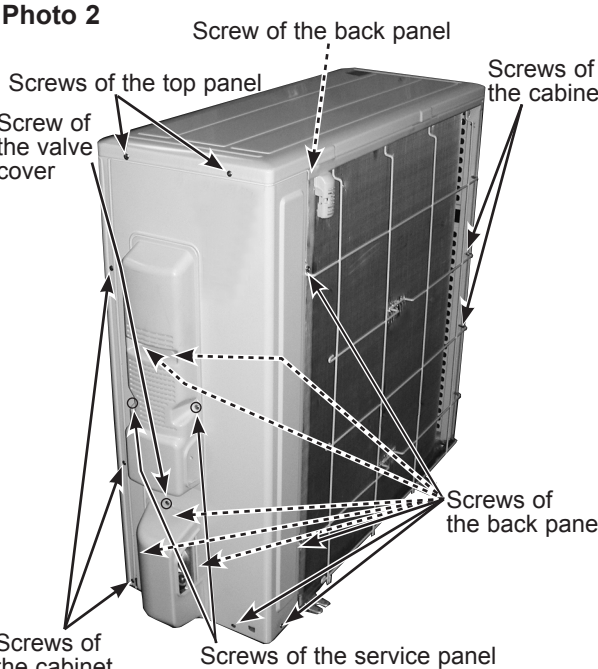

**Photo 17**



## 11-2. MUZ-WR24NA

**NOTE:** Turn OFF the power supply before disassembly.

OPERATING PROCEDURE	PHOTOS/FIGURES
<p><b>1. Removing the cabinet</b></p> <ol style="list-style-type: none"> <li>(1) Remove all the screws of the service panel.</li> <li>(2) Remove all the screws of the top panel.</li> <li>(3) Remove the screw of the valve cover.</li> <li>(4) Remove the service panel.</li> <li>(5) Remove all the screws fixing the conduit cover.</li> <li>(6) Remove the conduit cover.</li> <li>(7) Remove the screw of fixing the conduit plate.</li> <li>(8) Remove the conduit plate.</li> <li>(9) Remove the top panel.</li> <li>(10) Remove the valve cover.</li> <li>(11) Disconnect the power supply and indoor/outdoor connecting wire.</li> <li>(12) Remove all the screws of the cabinet.</li> <li>(13) Remove the cabinet.</li> <li>(14) Remove all the screws of the back panel.</li> <li>(15) Remove the back panel.</li> </ol> <p><b>Photo 3</b> Screws of the conduit cover</p>  <p><b>Photo 4</b> Screw of the conduit plate</p> 	<p><b>Photo 1</b></p>  <p>Screws of the top panel</p> <p>Screws of the cabinet</p> <p>Screws of the cabinet</p> <p>Screws of the cabinet</p> <p><b>Photo 2</b></p>  <p>Screw of the back panel</p> <p>Screws of the top panel</p> <p>Screws of the cabinet</p> <p>Screw of the valve cover</p> <p>Screws of the back panel</p> <p>Screws of the service panel</p> <p>Screws of the cabinet</p>

## OPERATING PROCEDURE

## PHOTOS/FIGURES

### 2. Removing the inverter assembly, inverter P.C. board

- (1) Remove the cabinet and panels. (Refer to section 1.)
- (2) Disconnect the lead wire to the reactor and the following connectors:  
<Inverter P.C. board>  
CN721 (R.V. coil)  
CN931, CN932 (Fan motor)  
CN641 (Defrost thermistor and discharge temperature thermistor)  
CN643 (Ambient temperature thermistor)  
CN644 (Outdoor heat exchanger temperature thermistor)  
CN724 (LEV)
- (3) Remove the compressor connector.
- (4) Remove the screw fixing the heat sink support and the separator.
- (5) Remove the fixing screws of the terminal block support and the back panel.
- (6) Remove the inverter assembly.
- (7) Remove the screw of the ground wire, screw of the P.C. board cover and screws of the terminal block support.
- (8) Remove the heat sink support from the P.C. board support.
- (9) Remove the screw of the inverter P.C. board and the inverter P.C. board from the P.C. board support.

### 3. Removing R.V. coil

- (1) Remove the cabinet and panels. (Refer to section 1.)
- (2) Disconnect the following connector:  
<Inverter P.C. board>  
CN721 (R.V. coil)
- (3) Remove the R.V. coil.

Photo 7

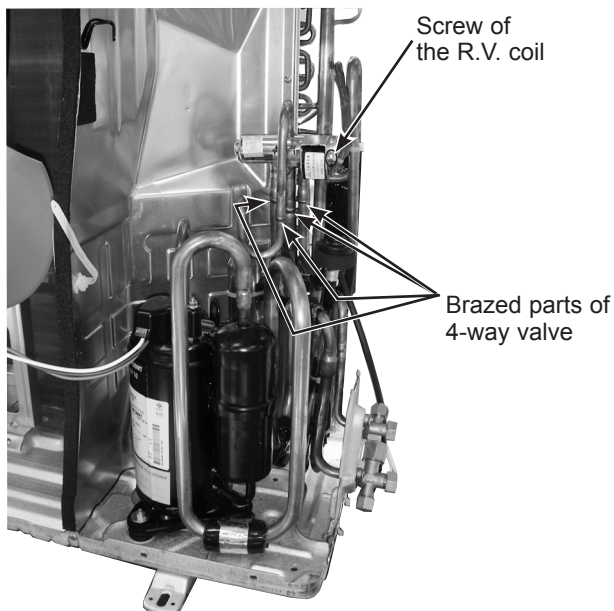

Photo 5

Screw of the heat sink support and the separator

Screws of the terminal block support and the back panel

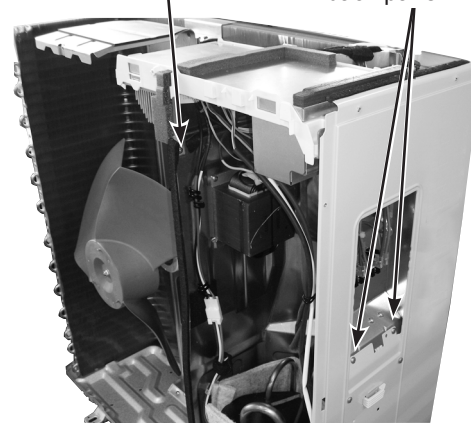
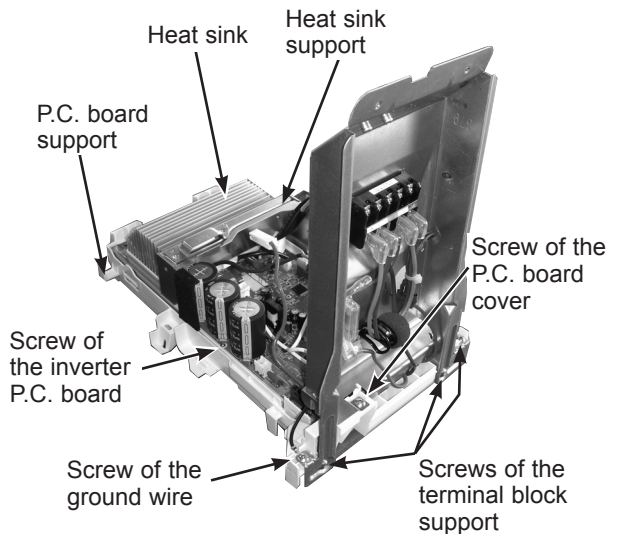
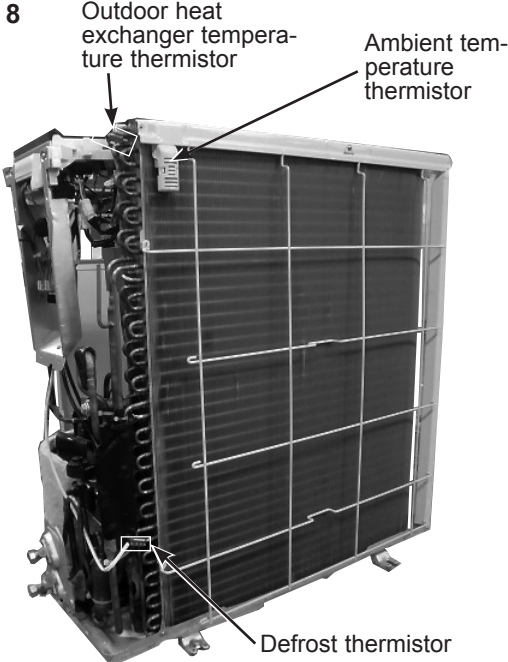
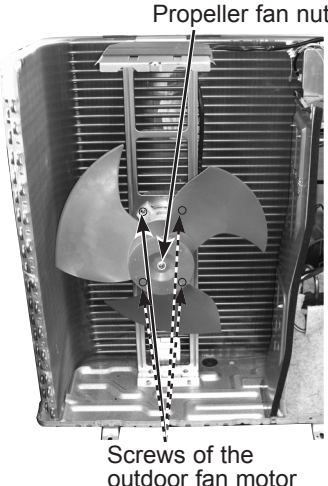



Photo 6



OPERATING PROCEDURE	PHOTOS/FIGURES
<p><b>4. Removing the discharge temperature thermistor, defrost thermistor, outdoor heat exchanger temperature thermistor and ambient temperature thermistor</b></p> <ol style="list-style-type: none"> <li>(1) Remove the cabinet and panels. (Refer to section 1.)</li> <li>(2) Disconnect the lead wire to the reactor and the following connectors: &lt;Inverter P.C. board&gt; CN641 (Defrost thermistor and discharge temperature thermistor) CN643 (Ambient temperature thermistor) CN644 (Outdoor heat exchanger temperature thermistor)</li> <li>(3) Pull out the discharge temperature thermistor from its holder.</li> <li>(4) Pull out the defrost thermistor from its holder.</li> <li>(5) Pull out the outdoor heat exchanger temperature thermistor from its holder.</li> <li>(6) Pull out the ambient temperature thermistor from its holder.</li> </ol>	<p><b>Photo 8</b></p>  <p>Outdoor heat exchanger temperature thermistor</p> <p>Ambient temperature thermistor</p> <p>Defrost thermistor</p>
<p><b>5. Removing outdoor fan motor</b></p> <ol style="list-style-type: none"> <li>(1) Remove the top panel, cabinet and service panel. (Refer to section 1.)</li> <li>(2) Disconnect the following connectors: &lt;Inverter P.C. board&gt; CN931 and CN932 (Fan motor)</li> <li>(3) Remove the propeller fan nut.</li> <li>(4) Remove the propeller fan.</li> <li>(5) Remove all the screws fixing the fan motor.</li> <li>(6) Remove the fan motor.</li> </ol> <p><b>NOTE:</b> The propeller fan nut is a reverse thread.</p>	<p><b>Photo 9</b></p>  <p>Propeller fan nut</p> <p>Screws of the outdoor fan motor</p>
<p><b>6. Removing the compressor and 4-way valve</b></p> <ol style="list-style-type: none"> <li>(1) Remove the top panel, cabinet and service panel. (Refer to section 1.)</li> <li>(2) Remove the back panel. (Refer to section 1.)</li> <li>(3) Remove the inverter assembly. (Refer to section 2.)</li> <li>(4) Recover gas from the refrigerant circuit.</li> </ol> <p><b>NOTE:</b> Recover gas from the pipes until the pressure gauge shows 0 PSIG.</p> <ol style="list-style-type: none"> <li>(5) Detach the brazed part of the suction and the discharge pipe connected with compressor.</li> <li>(6) Remove the compressor nuts.</li> <li>(7) Remove the compressor.</li> <li>(8) Detach the brazed part of 4-way valve and pipe. (Photo 7)</li> </ol>	<p><b>Photo 10</b></p>  <p>Brazed part of the discharge pipe</p> <p>Discharge temperature thermistor</p> <p>Brazed part of the suction pipe</p>

# **mitsubishi electric corporation**

HEAD OFFICE: TOKYO BUILDING, 2-7-3, MARUNOUCHI, CHIYODA-KU, TOKYO 100-8310, JAPAN

© Copyright 2018 MITSUBISHI ELECTRIC CORPORATION

Issued: Aug. 2019. No. OBH819 REVISED EDITION-B

Issued: Jan. 2019. No. OBH819 REVISED EDITION-A

Published: Sep. 2018. No. OBH819

Made in Japan

Specifications are subject to change without notice.