

SPLIT-TYPE AIR CONDITIONERS

INDOOR UNIT

Revision B:
• 9-7. TEST POINT DIAGRAM AND VOLTAGE has been modified.
OBH685 REVISED EDITION-A is void.

No. OBH685
REVISED EDITION-B

SERVICE MANUAL

Models

- MSZ-HE09NA**
- MSZ-HE12NA**
- MSZ-HE15NA**
- MSZ-HE18NA**
- MSZ-HE24NA**

Outdoor unit service manual
MUZ-HE•NA Series (OBH686)

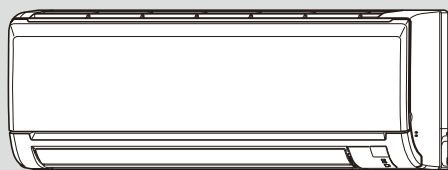

- MSZ-HE09NA**
- MSZ-HE12NA**
- MSZ-HE15NA**
- MSZ-HE18NA**



CONTENTS

| | |
|-------------------------------|----|
| 1. TECHNICAL CHANGES | 2 |
| 2. PART NAMES AND FUNCTIONS | 3 |
| 3. SPECIFICATION | 5 |
| 4. OUTLINES AND DIMENSIONS | 7 |
| 5. WIRING DIAGRAM | 8 |
| 6. REFRIGERANT SYSTEM DIAGRAM | 9 |
| 7. SERVICE FUNCTIONS | 10 |
| 8. MICROPROCESSOR CONTROL | 12 |
| 9. TROUBLESHOOTING | 16 |
| 10. DISASSEMBLY INSTRUCTIONS | 32 |

PARTS CATALOG (OBB685)

Use the specified refrigerant only

Never use any refrigerant other than that specified.

Doing so may cause a burst, an explosion, or fire when the unit is being used, serviced, or disposed of.

Correct refrigerant is specified in the manuals and on the spec labels provided with our products.

We will not be held responsible for mechanical failure, system malfunction, unit breakdown or accidents caused by failure to follow the instructions.

<Preparation before the repair service>

- Prepare the proper tools.
- Prepare the proper protectors.
- Provide adequate ventilation.
- After stopping the operation of the air conditioner, turn off the power-supply breaker and pull the power plug.
- Discharge the capacitor before the work involving the electric parts.

<Precautions during the repair service>

- Do not perform the work involving the electric parts with wet hands.
- Do not pour water into the electric parts.
- Do not touch the refrigerant.
- Do not touch the hot or cold areas in the refrigeration cycle.
- When the repair or the inspection of the circuit needs to be done without turning off the power, exercise great caution not to touch the live parts.

WARNING

- When the refrigeration circuit has a leak, do not execute pump down with the compressor.
- When pumping down the refrigerant, stop the compressor before disconnecting the refrigerant pipes. The compressor may burst if air etc. get into it.
- When opening or closing the valve below freezing temperatures, refrigerant may spurt out from the gap between the valve stem and the valve body, resulting in injuries.

Revision A:

- 9-7. TEST POINT DIAGRAM AND VOLTAGE has been modified.

Revision B:

- 9-7. TEST POINT DIAGRAM AND VOLTAGE has been modified.

1

TECHNICAL CHANGES

MSZ-HE09NA

MSZ-HE12NA

MSZ-HE15NA

MSZ-HE18NA

MSZ-HE24NA

1. New model

2

PART NAMES AND FUNCTIONS

MSZ-HE09NA MSZ-HE12NA MSZ-HE15NA MSZ-HE18NA

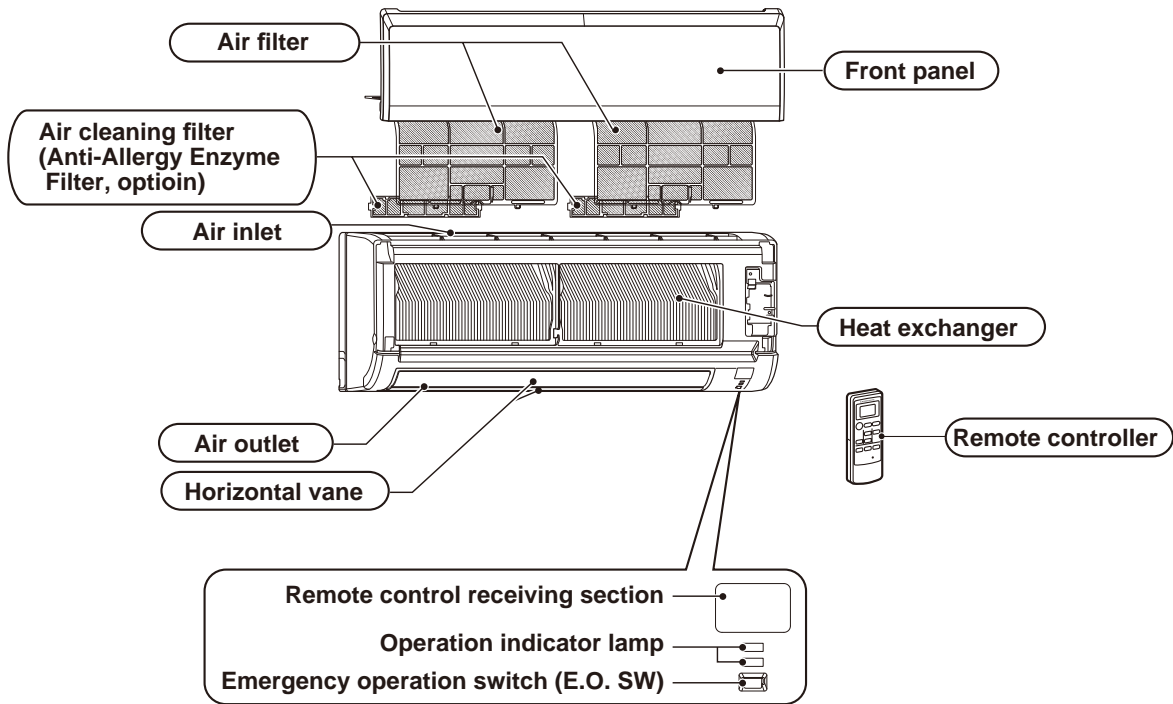

ACCESSORIES

| Model | MSZ-HE09/12/15/18NA |
|---|---------------------|
| ① Installation plate | 1 |
| ② Attachment screws for the installation plate 4 x 25 mm | 5 |
| ③ Battery (AAA) for the remote controller | 2 |
| ④ Wireless remote controller | 1 |
| ⑤ Felt tape (For left or left-rear piping) | 1 |
| ⑥ Air cleaning filter | 2 |

MSZ-HE24NA

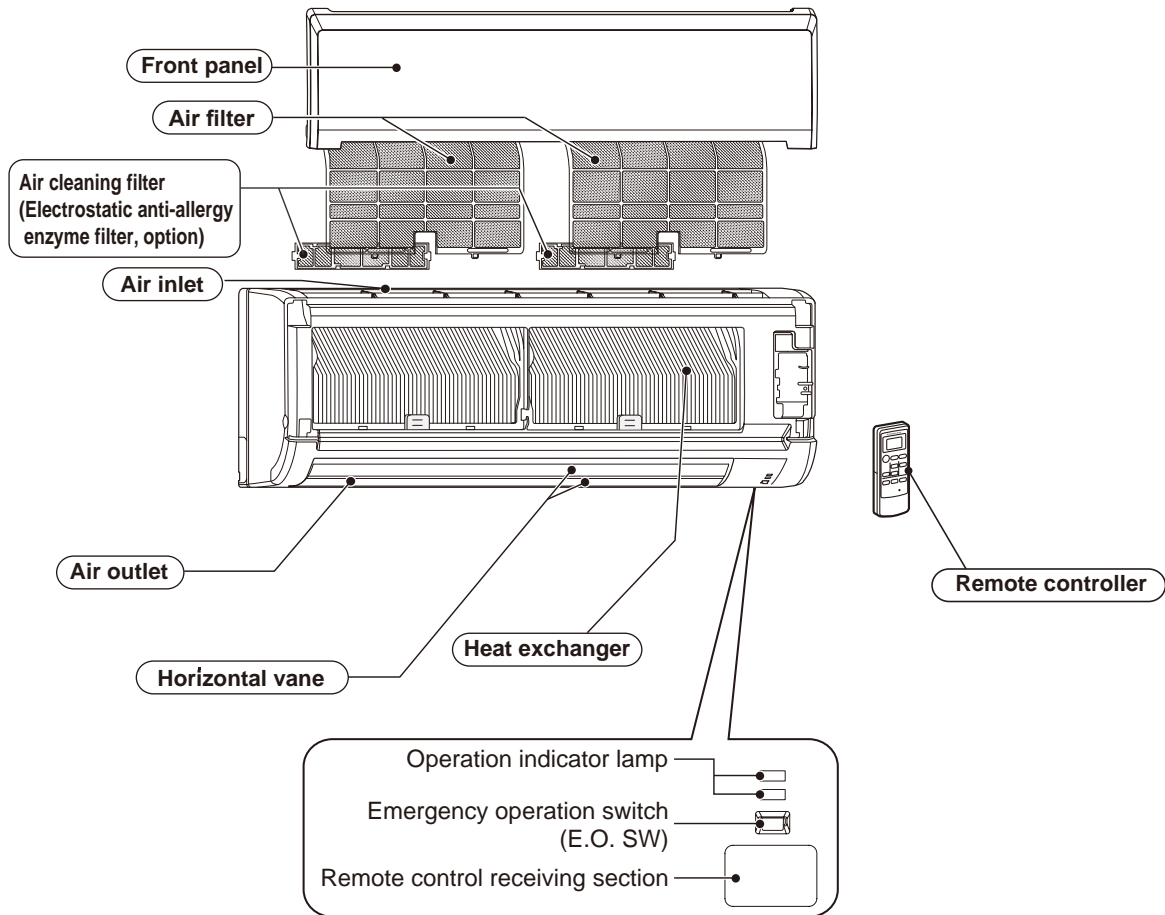

ACCESSORIES

| Model | MSZ-HE24NA |
|---|------------|
| ① Installation plate | 1 |
| ② Attachment screws for the installation plate 4 x 25 mm | 7 |
| ③ Battery (AAA) for the remote controller | 2 |
| ④ Wireless remote controller | 1 |
| ⑤ Felt tape (For left or left-rear piping) | 1 |
| ⑥ Air cleaning filter | 2 |

3

SPECIFICATION

| Indoor model | | | MSZ-HE09NA | MSZ-HE12NA |
|--|----------------------|-------|--------------------------------------|-------------|
| Power supply | V, phase, Hz | | 208/230, 1, 60 | |
| Max. fuse size (time delay)/ Disconnect switch | A | | 15 | |
| Min. circuit ampacity | A | | 1.0 | |
| Fan motor | F.L.A | | 0.76 | |
| Airflow Super High - High - Med. - Low | COOL Dry (Wet) | CFM | 399-321-237-170 (364-286-201-134) | |
| | HEAT Dry | CFM | 406-321-237-170 | |
| Moisture removal | pt./h | | 1.5 | 2.5 |
| Sound level Super High - High - Med. - Low | Cooling | dB(A) | 43-37-30-22 | 45-37-30-22 |
| | Heating | dB(A) | 43-37-30-22 | |
| Cond. drain connection O.D. | in. | | 5/8 | |
| Dimensions | W | in. | 31-7/16 | |
| | D | | 9-1/8 | |
| | H | | 11-5/8 | |
| Weight | lb. | | 22 | |
| External finish | Munsell 1.0Y 9.2/0.2 | | | |
| Control voltage (by built-in transformer) | 12 - 24 V DC | | | |

| Indoor model | | | MSZ-HE15NA | MSZ-HE18NA | MSZ-HE24NA |
|--|----------------------|-------|--------------------------------------|--------------------------------------|--------------------------------------|
| Power supply | V, phase, Hz | | 208/230, 1, 60 | | |
| Max. fuse size (time delay)/ Disconnect switch | A | | 15 | 20 | |
| Min. circuit ampacity | A | | 1.0 | | |
| Fan motor | F.L.A | | 0.76 | | |
| Airflow Super High - High - Med. - Low | COOL Dry (Wet) | CFM | 533-420-335-272 (498-385-300-237) | 533-420-339-275 (498-385-304-240) | 629-544-470-388 (562-486-420-347) |
| | HEAT Dry | CFM | 463-367-304-247 | 512-431-339-275 | 629-544-470-360 |
| Moisture removal | pt./h | | 2.7 | 4.6 | 5.1 |
| Sound level Super High - High - Med. - Low | Cooling | dB(A) | 49-44-38-32 | 49-44-38-33 | 49-45-41-34 |
| | Heating | dB(A) | 46-40-35-30 | 48-43-38-33 | 49-45-41-32 |
| Cond. drain connection O.D. | in. | | 5/8 | | |
| Dimensions | W | in. | 31-7/16 | | 43-5/16 |
| | D | | 9-1/8 | | 9-3/8 |
| | H | | 11-5/8 | | 12-13/16 |
| Weight | lb. | | 22 | 37 | |
| External finish | Munsell 1.0Y 9.2/0.2 | | | | |
| Control voltage (by built-in transformer) | 12 - 24 V DC | | | | |

NOTE: Test conditions are based on AHRI 210/240.

3-1. OPERATING RANGE

(1) POWER SUPPLY

| | Rated voltage | Guaranteed voltage (V) |
|-------------|-------------------------------|--|
| Indoor unit | 208/230 V 1 phase 60 Hz | Min. 187 208 230 Max. 253 |

(2) OPERATION

| Mode | Condition | Intake air temperature (°F) | | | |
|---------|----------------------|-----------------------------|----|---------|----|
| | | Indoor | | Outdoor | |
| | | DB | WB | DB | WB |
| Cooling | Standard temperature | 80 | 67 | 95 | — |
| | Maximum temperature | 90 | 73 | 115 | — |
| | Minimum temperature | 67 | 57 | 14 | — |
| | Maximum humidity | 78% | | — | |
| Heating | Standard temperature | 70 | 60 | 47 | 43 |
| | Maximum temperature | 80 | 67 | 75 | 65 |
| | Minimum temperature | 70 | 60 | -4 | -5 |

3-2. OUTLET AIR SPEED AND COVERAGE

| Model | Mode | Function | Airflow (CFM) | Air speed (ft./s.) | Coverage (ft.) |
|-------------------|------|----------|---------------|--------------------|----------------|
| MSZ-HE09NA | HEAT | Dry | 406 | 20.6 | 29.5 |
| | COOL | Dry | 321 | 16.3 | 23.5 |
| | | Wet | 286 | 14.5 | 21.0 |
| MSZ-HE12NA | HEAT | Dry | 406 | 20.6 | 29.5 |
| | COOL | Dry | 321 | 16.3 | 23.5 |
| | | Wet | 286 | 14.5 | 21.0 |
| MSZ-HE15NA | HEAT | Dry | 463 | 23.4 | 33.5 |
| | COOL | Dry | 420 | 21.3 | 30.5 |
| | | Wet | 385 | 19.5 | 28.0 |
| MSZ-HE18NA | HEAT | Dry | 512 | 25.9 | 36.9 |
| | COOL | Dry | 420 | 21.3 | 30.5 |
| | | Wet | 385 | 19.5 | 28.0 |
| MSZ-HE24NA | HEAT | Dry | 738 | 18.0 | 36.9 |
| | COOL | Dry | 738 | 18.0 | 36.9 |
| | | Wet | 661 | 16.1 | 33.2 |

- The air coverage is the figure up to the position where the air speed is 1 ft./s., when air is blown out horizontally from the unit properly at the High speed position. The coverage should be used only as a general guideline since it varies according to the size of the room and furniture arranged inside the room.

4

OUTLINES AND DIMENSIONS

MSZ-HE09NA MSZ-HE12NA MSZ-HE15NA MSZ-HE18NA

Unit: inch

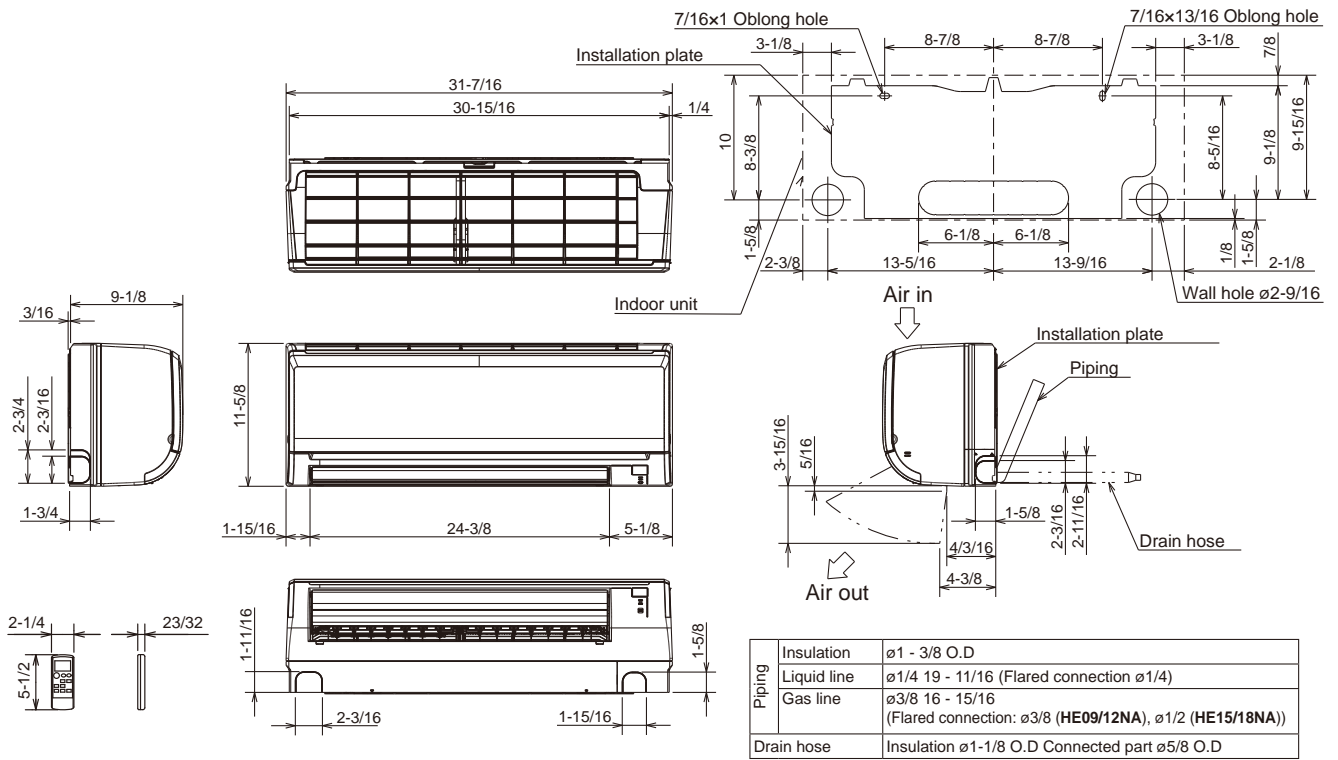

MSZ-HE24NA

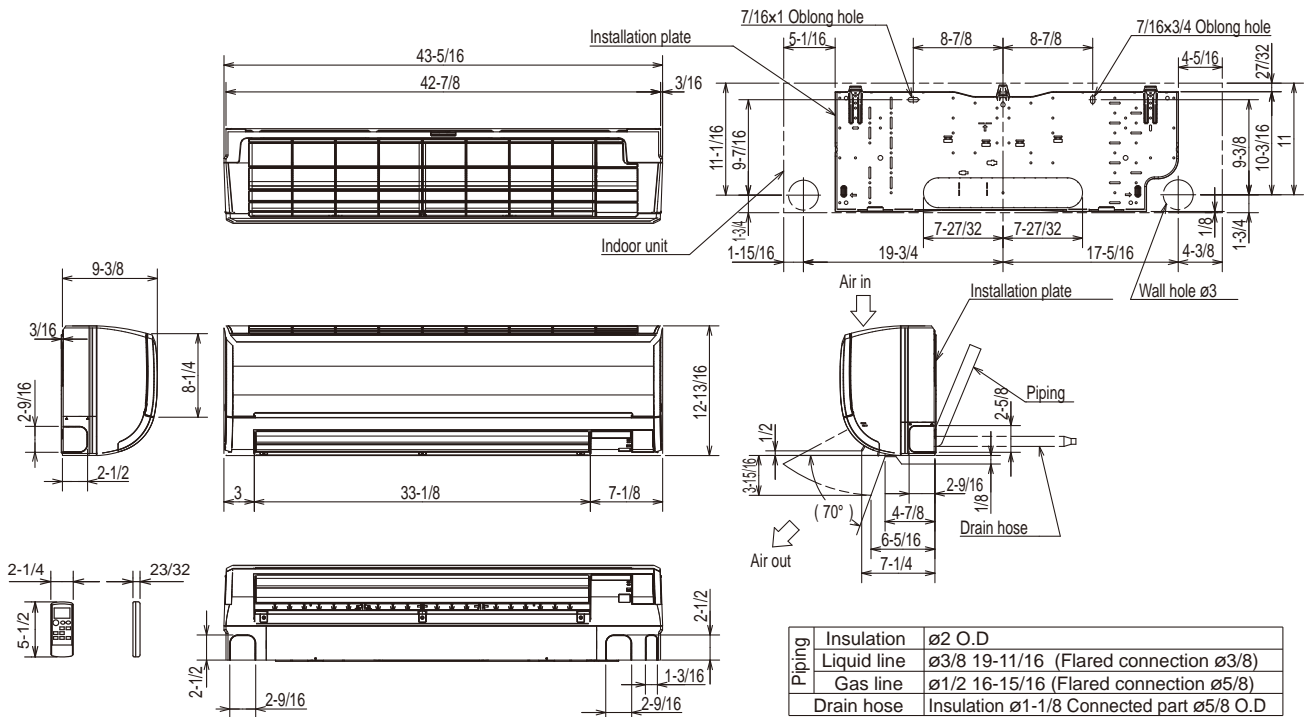

5

WIRING DIAGRAM

MSZ-HE09NA MSZ-HE12NA MSZ-HE15NA MSZ-HE18NA

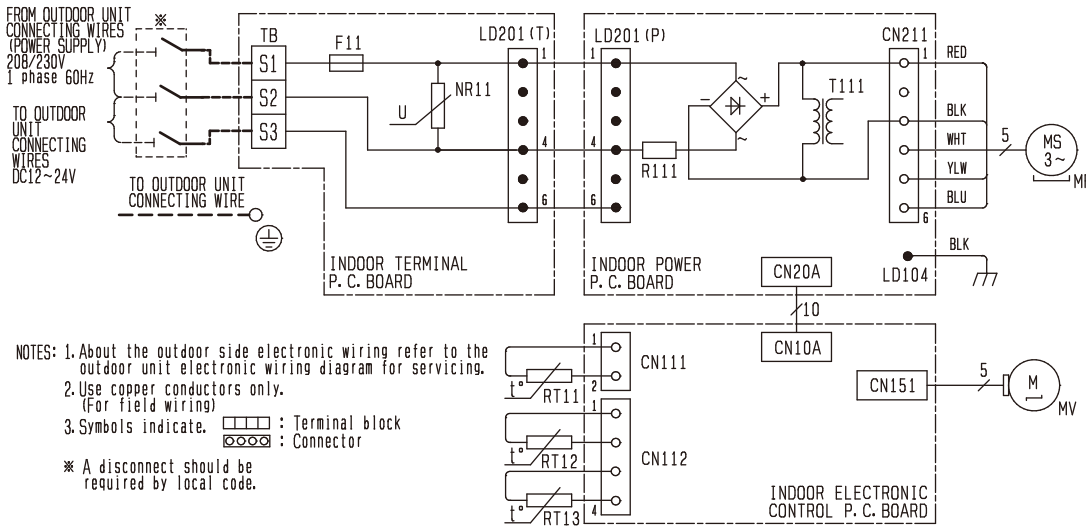

| SYMBOL | NAME |
|--------|------------------------------|
| F11 | FUSE (T3. 15AL250V) |
| MF | FAN MOTOR |
| MV | VANE MOTOR (HORIZONTAL) |
| NR11 | VARISTOR |
| R111 | RESISTOR |
| RT11 | ROOM TEMP. THERMISTOR |
| RT12 | COIL TEMP. THERMISTOR (MAIN) |
| RT13 | COIL TEMP. THERMISTOR (SUB) |
| T111 | TRANSFORMER |
| TB | TERMINAL BLOCK |

MSZ-HE24NA

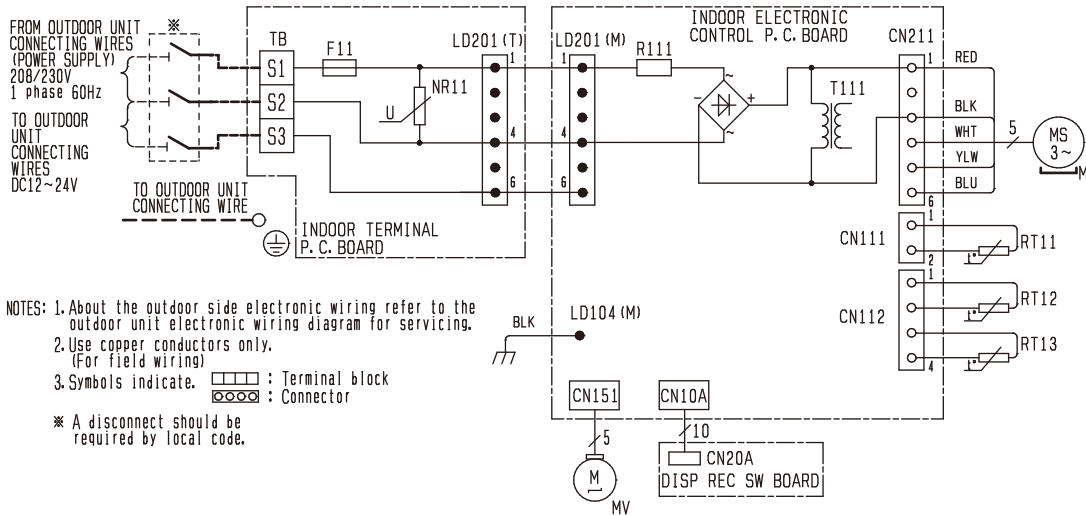

| SYMBOL | NAME |
|--------|------------------------------|
| F11 | FUSE (T3. 15AL250V) |
| MF | FAN MOTOR |
| MV | VANE MOTOR (HORIZONTAL) |
| NR11 | VARISTOR |
| R111 | RESISTOR |
| RT11 | ROOM TEMP. THERMISTOR |
| RT12 | COIL TEMP. THERMISTOR (MAIN) |
| RT13 | COIL TEMP. THERMISTOR (SUB) |
| T111 | TRANSFORMER |
| TB | TERMINAL BLOCK |

6

REFRIGERANT SYSTEM DIAGRAM

MSZ-HE09NA MSZ-HE12NA MSZ-HE15NA MSZ-HE18NA

Unit: inch

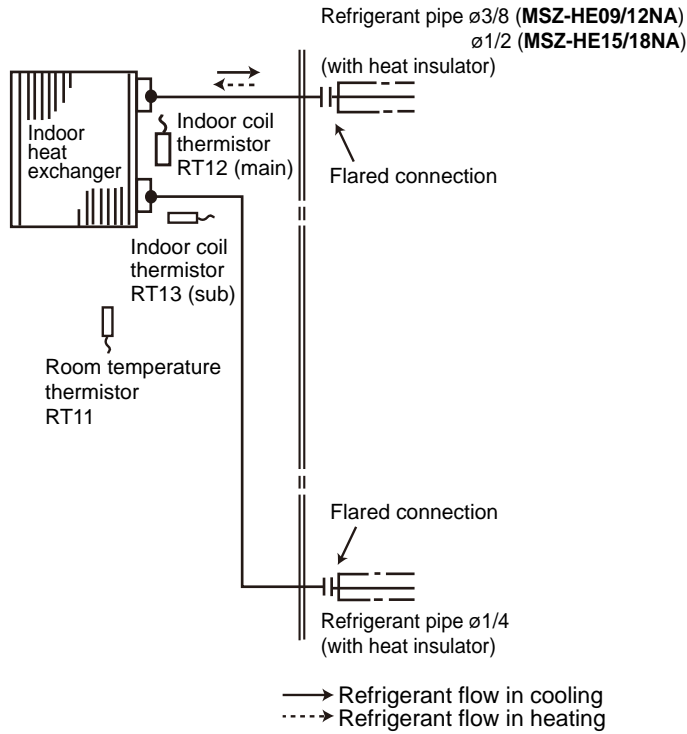

MSZ-HE24NA

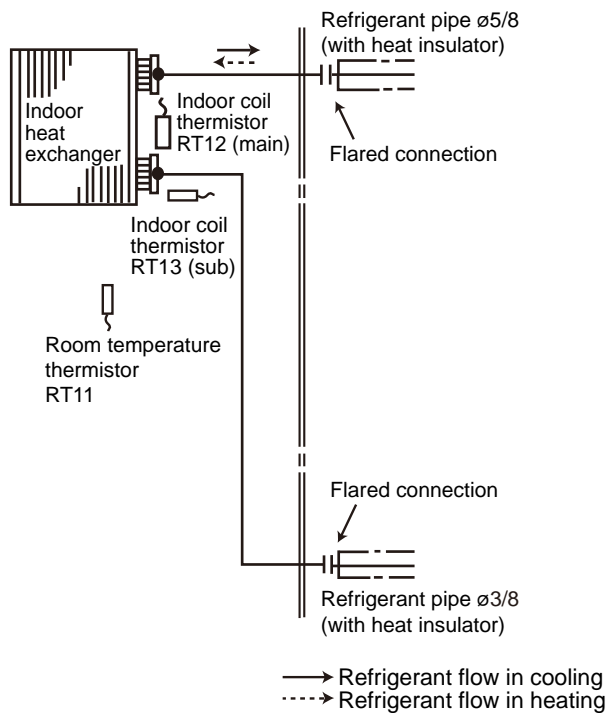

MSZ-HE09NA MSZ-HE12NA MSZ-HE15NA MSZ-HE18NA MSZ-HE24NA

7-1. TIMER SHORT MODE

For service, the following set time can be shortened by bridging JPG and JPS on the indoor electronic control P.C. board. (Refer to 9-7.)

- The set time for the ON/OFF timer can be reduced to 1 second for each minute.
- After the breaker is turned on, the time for starting the compressor, which normally takes 3 minutes, can be reduced to 3 seconds. Restarting the compressor, which takes 3 minutes, cannot be reduced.

7-2. P.C. BOARD MODIFICATION FOR INDIVIDUAL OPERATION

A maximum of 4 indoor units with wireless remote controllers can be used in a room.

In this case, to operate each indoor unit individually by each remote controller, P.C. boards of remote controller must be modified according to the number of the indoor unit.

How to modify the remote controller P.C. board

Remove batteries before modification.

The board has a print as shown below:

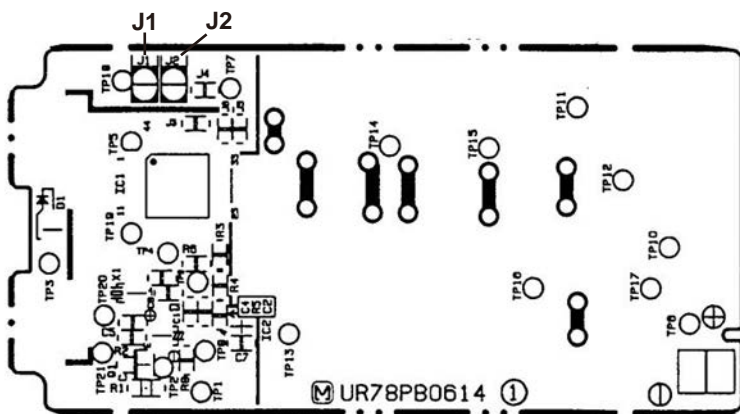

NOTE : For modification, take out the batteries and press the OPERATE/STOP (ON/OFF) button 2 or 3 times at first. After finish modification, put back the batteries then press the RESET button.

The P.C. board has the print “J1” and “J2”. Solder “J1” and “J2” according to the number of indoor unit as shown in Table 1. After modification, press the RESET button.

Table 1

| | 1 unit operation | 2 units operation | 3 units operation | 4 units operation |
|------------|------------------|-------------------|-------------------|-----------------------|
| No. 1 unit | No modification | Same as at left | Same as at left | Same as at left |
| No. 2 unit | — | Solder J1 | Same as at left | Same as at left |
| No. 3 unit | — | — | Solder J2 | Same as at left |
| No. 4 unit | — | — | — | Solder both J1 and J2 |

How to set the remote controller exclusively for particular indoor unit

After you turn the breaker ON, the first remote controller that sends the signal to the indoor unit will be regarded as the remote controller for the indoor unit.

The indoor unit will only accept the signal from the remote controller that has been assigned to the indoor unit once they are set. The setting will be cancelled if the breaker has turned OFF, or the power supply has shut down.

Please conduct the above setting once again after the power has restored.

7-3. AUTO RESTART FUNCTION

When the indoor unit is controlled with the remote controller, the operation mode, the set temperature, and the fan speed are memorized by the indoor electronic control P.C. board. "AUTO RESTART FUNCTION" automatically starts operation in the same mode just before the shut-off of the main power.

Operation

- ① If the main power has been cut, the operation settings remain.
- ② After the power is restored, the unit restarts automatically according to the memory.
(However, it takes at least 3 minutes for the compressor to start running.)

How to disable "AUTO RESTART FUNCTION"

- ① Turn OFF the main power of the unit.
- ② Solder the Jumper wire JR07 on the indoor electronic control P.C. board. (Refer to 9-7.)

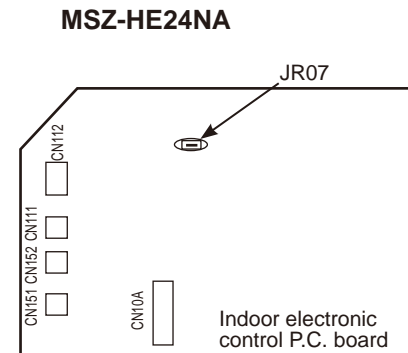
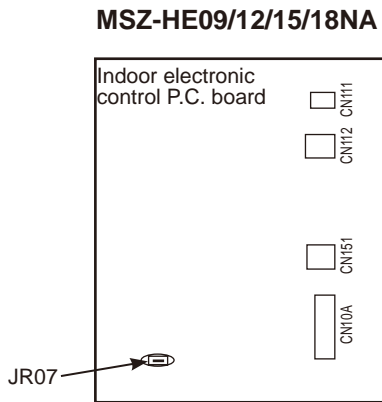

NOTE:

- The operation settings are memorized when 10 seconds have passed after the indoor unit was operated with the remote controller.
- If main power is turned OFF or a power failure occurs while AUTO START/STOP timer is active, the timer setting is cancelled.
- If the unit has been OFF with the remote controller before power failure, the auto restart function does not work as the power button of the remote controller is OFF.
- To prevent breaker OFF due to the rush of starting current, systematize other home appliance not to turn ON at the same time.
- When some air conditioners are connected to the same supply system, if they are operated before power failure, the starting current of all the compressors may flow simultaneously at restart.
Therefore, the special counter-measures are required to prevent the main voltage-drop or the rush of the starting current by adding to the system that allows the units to start one by one.

MSZ-HE09NA MSZ-HE12NA MSZ-HE15NA MSZ-HE18NA MSZ-HE24NA

WIRELESS REMOTE CONTROLLER

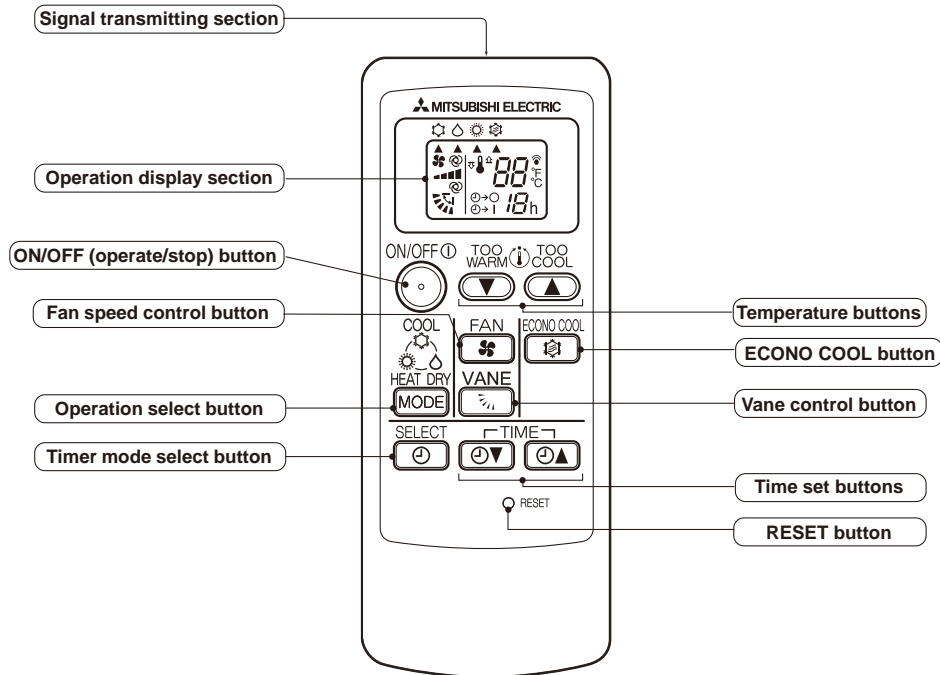





NOTE: Last setting will be stored after the unit is turned OFF with the remote controller. Indoor unit receives the signal of the remote controller with beeps.

INDOOR UNIT DISPLAY SECTION

Operation Indicator lamp

The operation indicator at the right side of the indoor unit indicates the operation state.

- The following indication applies regardless of shape of the indication.

| Indication | Operation state | Room temperature |
|--|---|---|
|   | The unit is operating to reach the set temperature | About 4°F (2°C) or more away from set temperature |
|   | The room temperature is approaching the set temperature | About 2 to 4°F (1 to 2°C) from set temperature |

-  Lit
-  Blinking
-  Not lit

8-1. COOL () OPERATION

- Press OPERATE/STOP (ON/OFF) button.
OPERATION INDICATOR lamp of the indoor unit turns ON with a beep tone.
- Select COOL mode with OPERATION SELECT button.
- Press TEMPERATURE buttons (TOO WARM or TOO COOL button) to select the desired temperature.
The setting range is 61 ~ 88°F (16 ~ 31°C).

1. Coil frost prevention

The compressor operational frequency is controlled by the temperature of the indoor heat exchanger to prevent the coil from frosting.

When the temperature of indoor heat exchanger becomes too low, the coil frost prevention mode works.

The indoor fan operates at the set speed and the compressor stops. This mode continues until the temperature of indoor heat exchanger rises.

2. Low outside temperature operation

When the outside temperature is lower, low outside temperature operation starts, and the outdoor fan slows or stops.

8-2. DRY (△) OPERATION

- (1) Press OPERATE/STOP (ON/OFF) button.
OPERATION INDICATOR lamp of the indoor unit turns ON with a beep tone.
- (2) Select DRY mode with OPERATION SELECT button.
- (3) The set temperature is determined from the initial room temperature.

1. Coil frost prevention

Coil frost prevention works the same way as that in COOL mode. (8-1.1.)

2. Low outside temperature operation

Low outside temperature operation works the same way as that in COOL mode. (8-1.2.)

8-3. HEAT (⊙) OPERATION

- (1) Press OPERATE/STOP (ON/OFF) button.
OPERATION INDICATOR lamp of the indoor unit turns ON with a beep tone.
- (2) Select HEAT mode with OPERATION SELECT button.
- (3) Press TEMPERATURE buttons (TOO WARM or TOO COOL button) to select the desired temperature.
The setting range is 61 ~ 88°F (16 ~ 31°C).

1. Cold air prevention control

When the compressor is not operating or is starting, and the temperature of indoor heat exchanger and/or the room temperature is low or when defrosting is being done, the indoor fan will stop or rotate in Very Low speed.

2. High pressure protection

The compressor operational frequency is controlled by the temperature of the indoor heat exchanger to prevent the condensing pressure from increasing excessively.

When the temperature of indoor heat exchanger becomes too high, the high pressure protection works.

The indoor fan operates following the cold air prevention control. This mode continues until the temperature of indoor heat exchanger falls.

3. Defrosting

Defrosting starts when the temperature of outdoor heat exchanger becomes too low.

The compressor stops once, the indoor/outdoor fans stop, the 4-way valve reverses and the compressor re-starts.

This mode continues until the temperature of outdoor heat exchanger rises or the fixed time passes.

8-4. AUTO VANE OPERATION

1. Horizontal vane

- (1) Vane motor drive

These models are equipped with a stepping motor for the horizontal vane. The rotating direction, speed, and angle of the motor are controlled by pulse signals (approximately 12 V) transmitted from indoor microprocessor.

- (2) The horizontal vane angle and mode change as follows by pressing VANE CONTROL button.

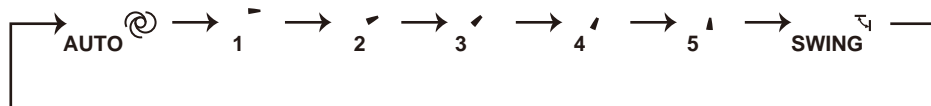

- (3) Positioning

To confirm the standard position, the vane moves until it touches the vane stopper. Then the vane is set to the selected angle.

Confirming of standard position is performed in the following cases:

- (a) When the operation starts or finishes (including timer operation).
- (b) When the test run starts.

- (4) VANE AUTO (Ⓐ) mode

In VANE AUTO mode, the microprocessor automatically determines the vane angle to make the optimum room temperature distribution.

In COOL and DRY operation
Vane angle is fixed to Horizontal position.

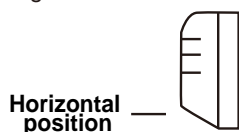

In HEAT operation
Vane angle is fixed to Angle 5.



(5) STOP (operation OFF) and ON TIMER standby

In the following cases, the horizontal vane returns to the closed position.

- (a) When OPERATE/STOP (ON/OFF) button is pressed (POWER OFF).
- (b) When the operation is stopped by the emergency operation.
- (c) When ON TIMER is ON standby.

(6) Dew prevention

During COOL or DRY operation with the vane angle at Angle 4 or 5 when the compressor cumulative operation time exceeds 1 hour, the vane angle automatically changes to Angle 1 for dew prevention.

(7) SWING (↕) mode

By selecting SWING mode with VANE CONTROL button, the horizontal vane swings vertically.

(8) Cold air prevention in HEAT operation

The horizontal vane position is set to Upward.

(9) ECONO COOL (🌀) operation (ECONOMical operation)

When ECONO COOL button is pressed in COOL mode, set temperature is automatically set 4°F(2°C) higher.

Also the horizontal vane swings in various cycle.

SWING operation makes you feel cooler than set temperature. So, even though the set temperature is higher, the air conditioner can keep comfort. As a result, energy can be saved.

To cancel this operation, select a different mode or press one of the following buttons in ECONO COOL operation: ECONO COOL or VANE CONTROL button.

8-5. TIMER OPERATION

1. How to set the timer

(1) Press OPERATE/STOP (ON/OFF) button to start the air conditioner.

(2) Press TIMER MODE SELECT button (SELECT) to select the operation.

“⊖→○”(OFF TIMER) → “⊖→|”(ON TIMER) → TIMER RELEASE

Each time this button is pressed, the timer mode is changed in sequence.

(3) Press TIME SET button (TIME) to set the timer.

Each time this button is pressed, the set time increases by 1 hour.

NOTE 1. Be sure to place the remote controller at the position where its signal can reach the air conditioner even during TIMER operation.

2. Reset the timer in the following cases, or the set time may deviate and other malfunctions may occur.

- A power failure occurs.
- The circuit breaker functions.

3. The OFF TIMER and ON TIMER can not be set at the same time.

(Example 1) Setting to stop the air conditioner 3 hours later.

① Press “SELECT” button to select “⊖→○”(OFF TIMER).

② Press “TIME” button to set the “3h”.

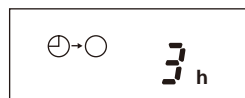

(Example 2) Setting to operate the air conditioner 7 hours later.

① Press “SELECT” button to select “⊖→|”(ON TIMER).

② Press “TIME” button to set the “7h”.



2. To release the timer

Press “SELECT” button until “⊖→○”(OFF TIMER) and “⊖→|”(ON TIMER) are not displayed.

8-6. EMERGENCY/TEST OPERATION

In the case of test run operation or emergency operation, use the emergency operation switch on the right side of the indoor unit. Emergency operation is available when the remote controller is missing or has failed, or when the batteries in the remote controller are running down. The unit will start and OPERATION INDICATOR lamp will light up.

The first 30 minutes of operation is the test run operation. This operation is for servicing. The indoor fan runs at High speed and the temperature control does not work.

After 30 minutes of test run operation, the system shifts to EMERGENCY COOL/HEAT MODE with a set temperature of 75°F (24°C). The fan speed shifts to Med.

All protective operations such as the coil frost prevention works even in the test run or emergency operation.

In the test run or emergency operation, the horizontal vane operates in VANE AUTO (Ⓜ) mode.

Emergency operation continues until the emergency operation switch is pressed once or twice or the unit receives any signal from the remote controller. In the latter case, normal operation will start.

| Operation mode | COOL | HEAT |
|-----------------|------------|------------|
| Set temperature | 75°F(24°C) | 75°F(24°C) |
| Fan speed | Med. | Med. |
| Horizontal vane | Auto | Auto |

The operation mode is indicated by the Operation Indicator lamp as following

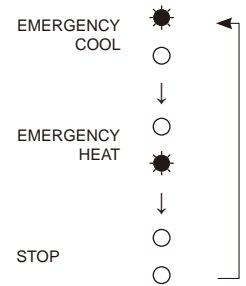

NOTE: Do not press the emergency operation switch during normal operation.

8-7. 3-MINUTE TIME DELAY OPERATION

When the system turns OFF, compressor will not restart for 3 minutes as 3-minute time delay function operates to protect compressor from overload.

8-8. Changing temperature indication (°F / °C)

- The preset unit is °F.
- °F → °C: Press RESET button while the temperature buttons are pressed.
- °C → °F: Press RESET button or remove the batteries .

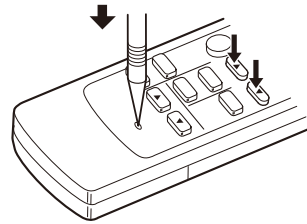

Press RESET button gently using a fine-tipped object.

MSZ-HE09NA MSZ-HE12NA MSZ-HE15NA MSZ-HE18NA MSZ-HE24NA

9-1. CAUTIONS ON TROUBLESHOOTING

1. Before troubleshooting, check the following

- 1) Check the power supply voltage.
- 2) Check the indoor/outdoor connecting wire for miswiring.

2. Take care of the following during servicing

- 1) Before servicing the air conditioner, be sure to turn OFF the unit first with the remote controller, and then after confirming the horizontal vane is closed, turn OFF the breaker and/or disconnect the power plug.
- 2) Be sure to turn OFF the power supply before removing the front panel, the cabinet, the top panel, and the P.C. board.
- 3) When removing the P.C. board, hold the edge of the board with care NOT to apply stress on the components.
- 4) When connecting or disconnecting the connectors, hold the connector housing. DO NOT pull the lead wires.

<Incorrect>



Lead wiring

<Correct>

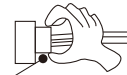

Connector housing

3. Troubleshooting procedure

- 1) Check if the OPERATION INDICATOR lamp on the indoor unit is blinking ON and OFF to indicate an abnormality. To make sure, check how many times the OPERATION INDICATOR lamp is blinking ON and OFF before starting service work.
- 2) Before servicing, verify that all connectors and terminals are connected properly.
- 3) When the electronic control P.C. board seems to be defective, check for disconnection of the copper foil pattern and burnt or discolored components.
- 4) When troubleshooting, refer to 9-2, 9-3 and 9-4.

4. How to replace batteries

Weak batteries may cause the remote controller malfunction.

In this case, replace the batteries to operate the remote controller normally.

- ① Remove the back lid and insert batteries. Then reattach the back lid.

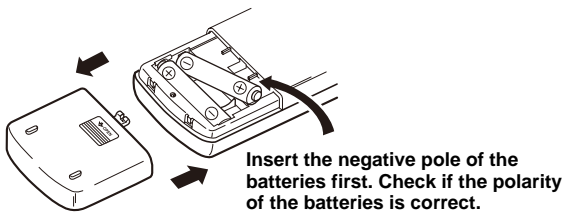

- ② Press RESET button with a fine-tipped object, and then use the remote controller.

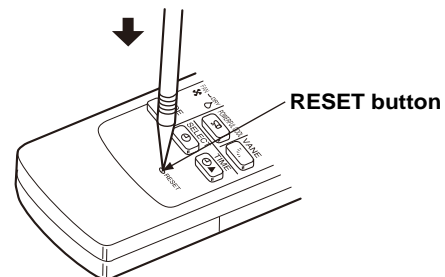

NOTE: 1. If RESET button is not pressed, the remote controller may not operate correctly.

2. This remote controller has a circuit to automatically reset the microcomputer when batteries are replaced.

This function is equipped to prevent the microcomputer from malfunctioning due to the voltage drop caused by the battery replacement.

3. Do not use the leaking batteries.

9-2. FAILURE MODE RECALL FUNCTION

Outline of the function

This air conditioner can memorize the abnormal condition which has occurred once.

Even though LED indication listed on the troubleshooting check table (9-4.) disappears, the memorized failure details can be recalled.

1. Flow chart of failure mode recall function for the indoor/outdoor unit

Operational procedure

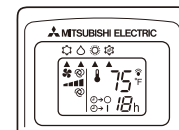
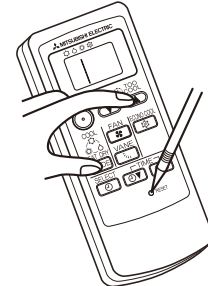
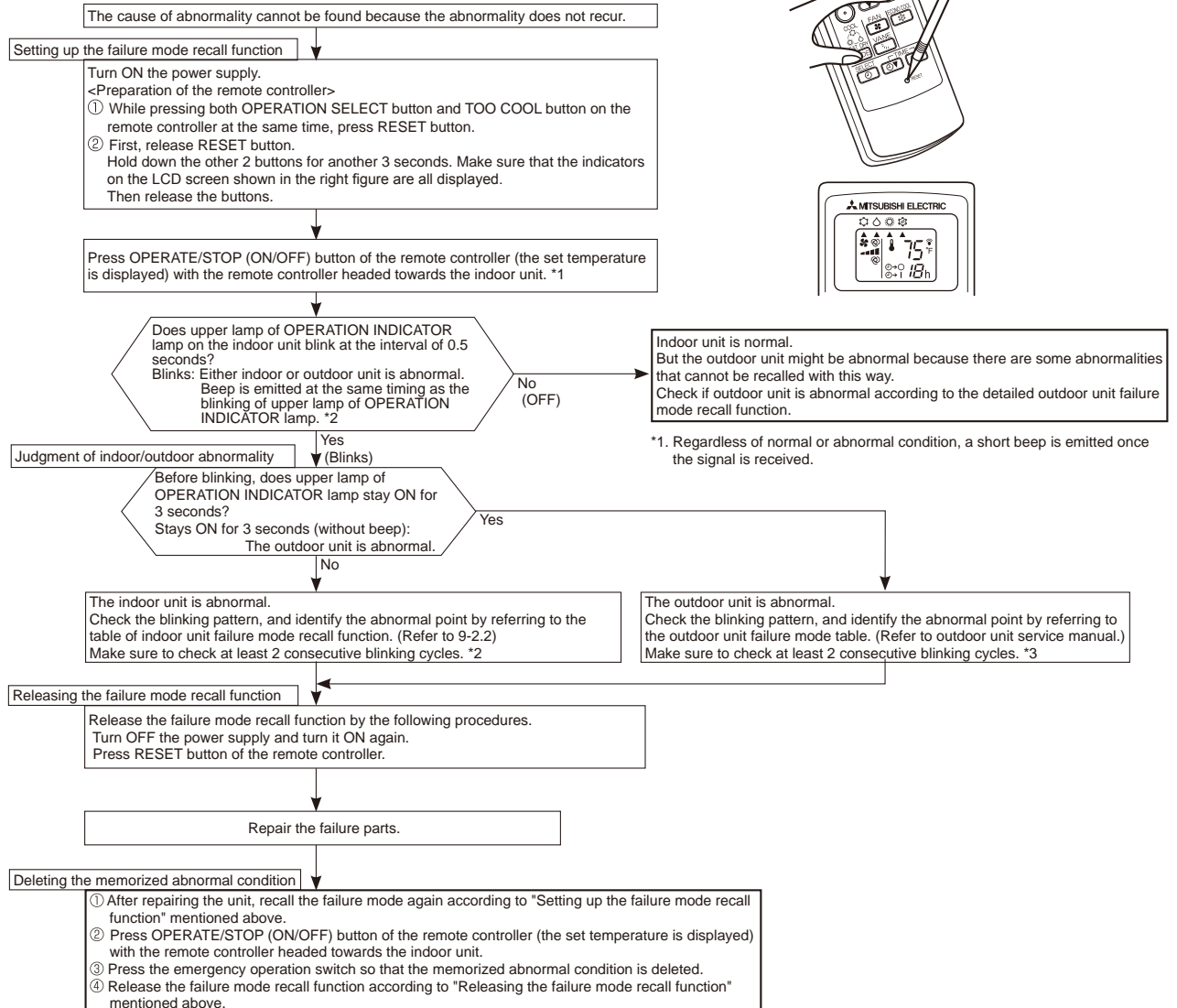

NOTE: 1. Make sure to release the failure mode recall function after it is set up, otherwise the unit cannot operate properly.
2. If the abnormal condition is not deleted from the memory, the last abnormal condition is kept memorized.

*2. Blinking pattern when the indoor unit is abnormal:

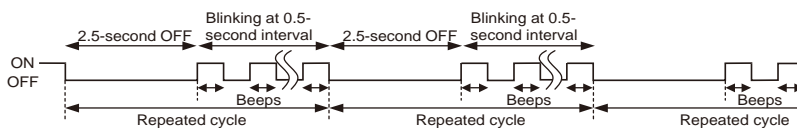

*3. Blinking pattern when the outdoor unit is abnormal:

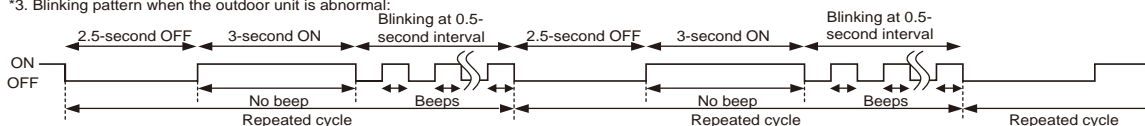



2. Table of indoor unit failure mode recall function

| Upper lamp of OPERATION INDICATOR lamp | Abnormal point (Failure mode) | Condition | Remedy |
|--|-------------------------------|--|---|
| Not lit | Normal | — | — |
| 1-time blink every 0.5-second | Room temperature thermistor | The room temperature thermistor short or open circuit is detected every 8 seconds during operation. | Refer to the characteristics of the room temperature thermistor (9-7.). |
| 2-time blink 2.5-second OFF | Indoor coil thermistor | The indoor coil thermistor short or open circuit is detected every 8 seconds during operation. | Refer to the characteristics of the main indoor coil thermistor, the sub indoor coil thermistor (9-7.). |
| 3-time blink 2.5-second OFF | Serial signal | The serial signal from outdoor unit is not received for a maximum of 6 minutes. | Refer to 9-6.Ⓢ "How to check miswiring and serial signal error". |
| 11-time blink 2.5-second OFF | Indoor fan motor | The rotational frequency feedback signal is not emitted for 12 seconds after the indoor fan motor is operated. | Refer to 9-6.Ⓐ "Check of indoor fan motor". |
| 12-time blink 2.5-second OFF | Indoor control system | It cannot properly read data in the nonvolatile memory of the indoor electronic control P.C. board. | Replace the indoor electronic control P.C. board. |

NOTE: Blinking patterns of this mode differ from the ones of TROUBLESHOOTING CHECK TABLE (9-4.).

9-3. INSTRUCTION OF TROUBLESHOOTING

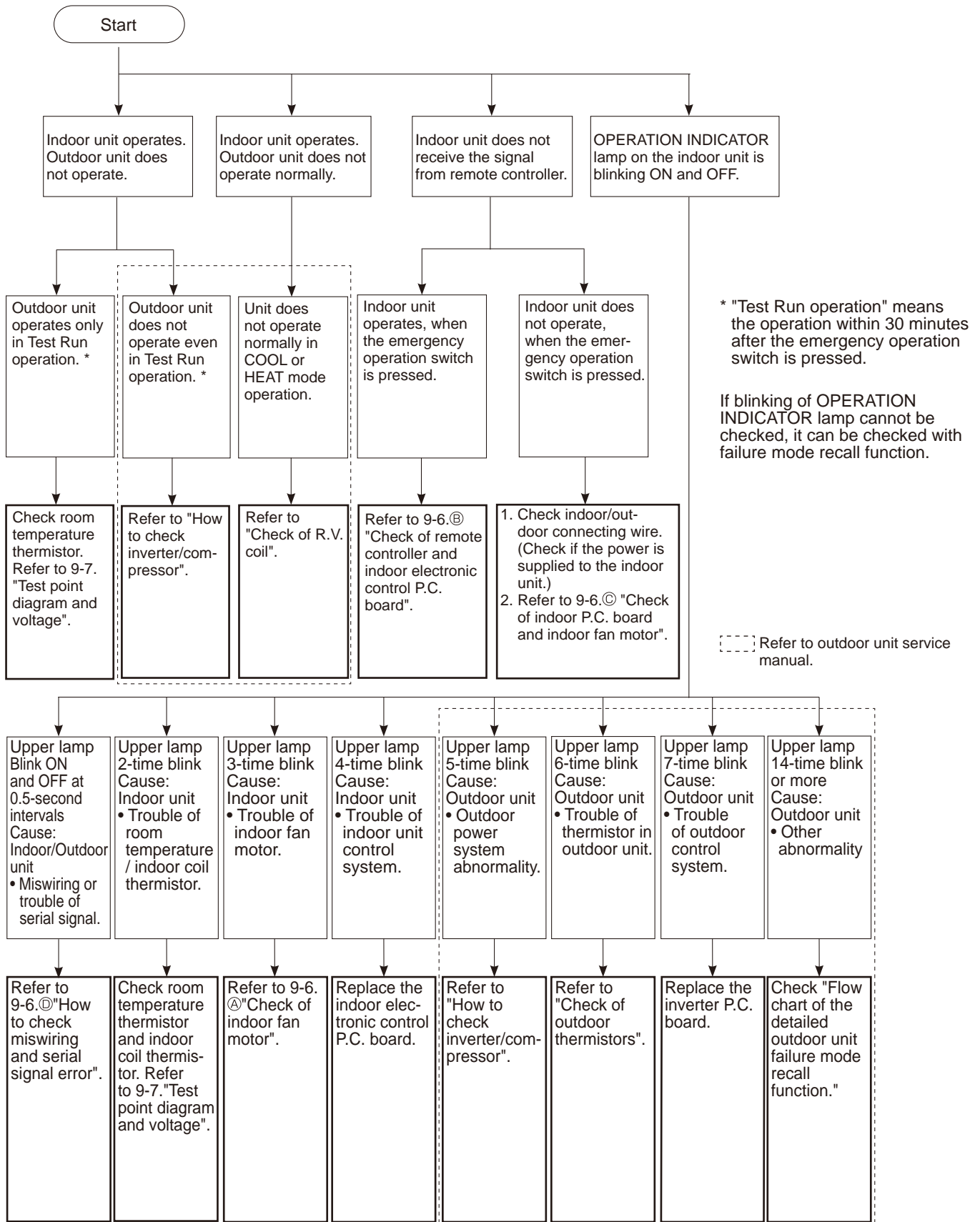

9-4. TROUBLESHOOTING CHECK TABLE

Before taking measures, make sure that the symptom reappears for accurate troubleshooting.

When the indoor unit has started operation and detected an abnormality of the following condition (the first detection after the power ON), the indoor fan motor turns OFF and OPERATION INDICATOR lamp blinks.

OPERATION INDICATOR



| No. | Abnormal point | Operation indicator lamp | Symptom | Condition | Remedy |
|-----|---|---|--|---|---|
| 1 | Miswiring or serial signal | Upper lamp blinks. 0.5-second ON ●○●○●○●○ 0.5-second OFF | Indoor unit and outdoor unit do not operate. | The serial signal from the outdoor unit is not received for 6 minutes. | <ul style="list-style-type: none"> Refer to 9-6. ⑩ "How to check miswiring and serial signal error". |
| 2 | Indoor coil thermistor Room temperature thermistor | Upper lamp blinks. 2-time blink ●○●○●○●○●○●○●○ 2.5-second OFF | | The indoor coil or the room temperature thermistor is short or open circuit. | <ul style="list-style-type: none"> Refer to the characteristics of indoor coil thermistor, and the room temperature thermistor (9-7.). |
| 3 | Indoor fan motor | Upper lamp blinks. 3-time blink ●○●○●○●○●○●○●○●○ 2.5-second OFF | | The rotational frequency feedback signal is not emitted during the indoor fan operation. | <ul style="list-style-type: none"> Refer to 9-6. ⑪ "Check of indoor fan motor". |
| 4 | Indoor control system | Upper lamp blinks. 4-time blink ●○●○●○●○●○●○●○●○●○ 2.5-second OFF | | It cannot properly read data in the nonvolatile memory of the indoor electronic control P.C. board. | <ul style="list-style-type: none"> Replace the indoor electronic control P.C. board. |
| 5 | Outdoor power system | Upper lamp blinks. 5-time blink ●○●○●○●○●○●○●○●○●○ 2.5-second OFF | | It consecutively occurs 3 times that the compressor stops for overcurrent protection or start-up failure protection within 1 minute after start-up. | <ul style="list-style-type: none"> Refer to "How to check of inverter/compressor". Refer to outdoor unit service manual Check the stop valve. |
| 6 | Outdoor thermistors | Upper lamp blinks. 6-time blink ●○●○●○●○●○●○●○●○●○ 2.5-second OFF | | The outdoor thermistors short or open circuit during the compressor operation. | <ul style="list-style-type: none"> Refer to "Check of outdoor thermistor". Refer to outdoor unit service manual. |
| 7 | Outdoor control system | Upper lamp blinks. 7-time blink ●○●○●○●○●○●○●○●○●○ 2.5-second OFF | | It cannot properly read data in the nonvolatile memory of the inverter P.C. board. | <ul style="list-style-type: none"> Replace the inverter P.C. board. Refer to outdoor unit service manual. |
| 8 | Other abnormality | Upper lamp blinks. 14-time blink or more ●○●○●○●○●○●○●○●○●○●○●○●○ 2.5-second OFF | | An abnormality other than above mentioned is detected. | <ul style="list-style-type: none"> Check the stop valve. Check the 4-way valve. Check the abnormality in detail using the failure mode recall function for outdoor unit. |
| 9 | Outdoor control system | Upper lamp lights up ● | | Outdoor unit does not operate | It cannot properly read data in the nonvolatile memory of the inverter P.C. board. |

9-5. TROUBLESHOOTING CRITERION OF MAIN PARTS

MSZ-HE09NA MSZ-HE12NA MSZ-HE15NA MSZ-HE18NA MSZ-HE24NA

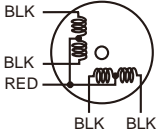
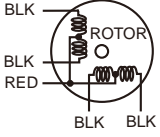
| Part name | Check method and criterion | Figure | | | | | | |
|---|--|------------------------|------------------------|-----------|----------------------------|---|-------------|---|
| Room temperature thermistor (RT11) Indoor coil thermistor (RT12, RT13) | Measure the resistance with a multimeter. Refer to 9-7. "Test point diagram and voltage", 2 or 3. "Indoor electronic control P.C. board", for the chart of thermistor. | | | | | | | |
| Indoor fan motor (MF) | Check 9-6.Ⓐ | | | | | | | |
| MSZ-HE09/12/15/18NA Vane motor (MV) | Measure the resistance between the terminals with a multimeter. (Temperature: 50 - 86°F (10 - 30°C)) <table border="1" data-bbox="464 573 1118 636"> <thead> <tr> <th data-bbox="464 573 807 604">Color of the lead wire</th> <th data-bbox="807 573 1118 604">Normal</th> </tr> </thead> <tbody> <tr> <td data-bbox="464 604 807 636">RED - BLK</td> <td data-bbox="807 604 1118 636">223 - 268 Ω</td> </tr> </tbody> </table> | Color of the lead wire | Normal | RED - BLK | 223 - 268 Ω |  | | |
| Color of the lead wire | Normal | | | | | | | |
| RED - BLK | 223 - 268 Ω | | | | | | | |
| MSZ-HE24NA Horizontal vane motor (MV) | Measure the resistance between the terminals with a multimeter. (Part temperature 50 ~ 86°F (10 ~ 30°C)) <table border="1" data-bbox="464 726 1254 789"> <thead> <tr> <th data-bbox="464 726 791 758"></th> <th data-bbox="791 726 1046 758">Color of the lead wire</th> <th data-bbox="1046 726 1254 758">Normal</th> </tr> </thead> <tbody> <tr> <td data-bbox="464 758 791 789">Horizontal vane motor (MV)</td> <td data-bbox="791 758 1046 789">RED-BLK</td> <td data-bbox="1046 758 1254 789">313 ~ 375 Ω</td> </tr> </tbody> </table> | | Color of the lead wire | Normal | Horizontal vane motor (MV) | RED-BLK | 313 ~ 375 Ω |  |
| | Color of the lead wire | Normal | | | | | | |
| Horizontal vane motor (MV) | RED-BLK | 313 ~ 375 Ω | | | | | | |

9-6. TROUBLESHOOTING FLOW

Ⓐ Check of indoor fan motor

MSZ-HE09/12/15/18NA

The indoor fan motor error has occurred, and the indoor fan does not operate.

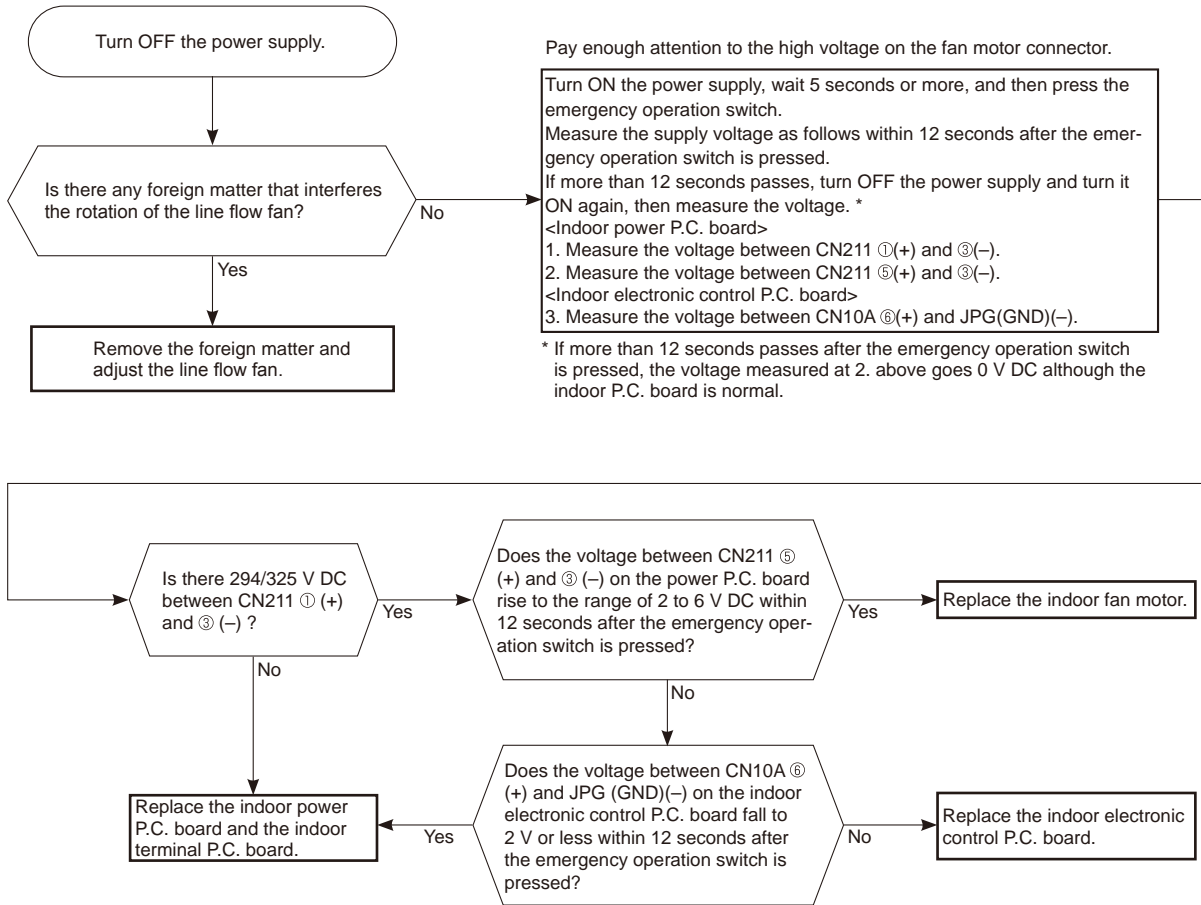

The indoor fan motor error has occurred, and the indoor fan repeats "12-second ON and 30-second OFF" 3 times, and then stops.

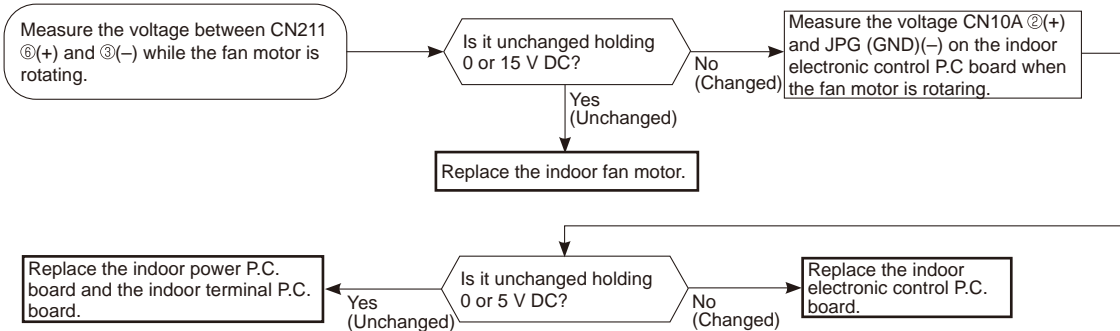

MSZ-HE24NA

The indoor fan motor error has occurred, and the indoor fan does not operate.

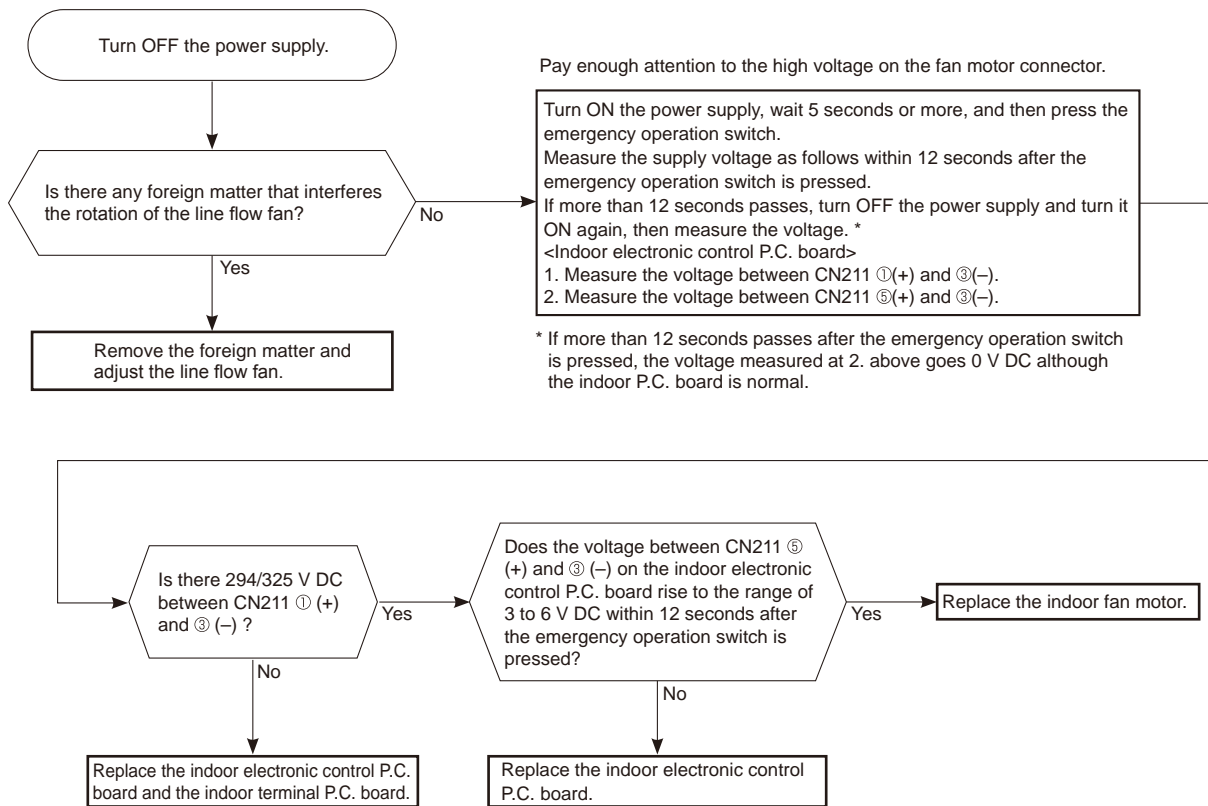

The indoor fan motor error has occurred, and the indoor fan repeats "12-second ON and 30-second OFF" 3 times, and then stops.

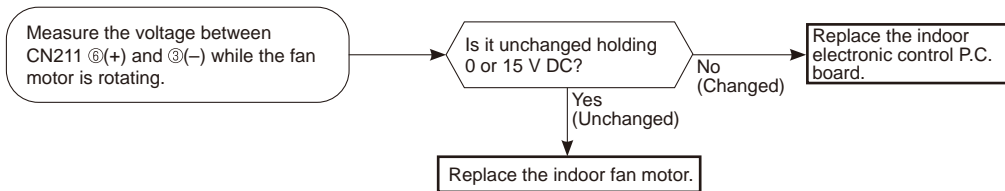

B Check of remote controller and indoor electronic control P.C. board

* Check if the remote controller is exclusive for this air conditioner.

MSZ-HE09/12/15/18NA

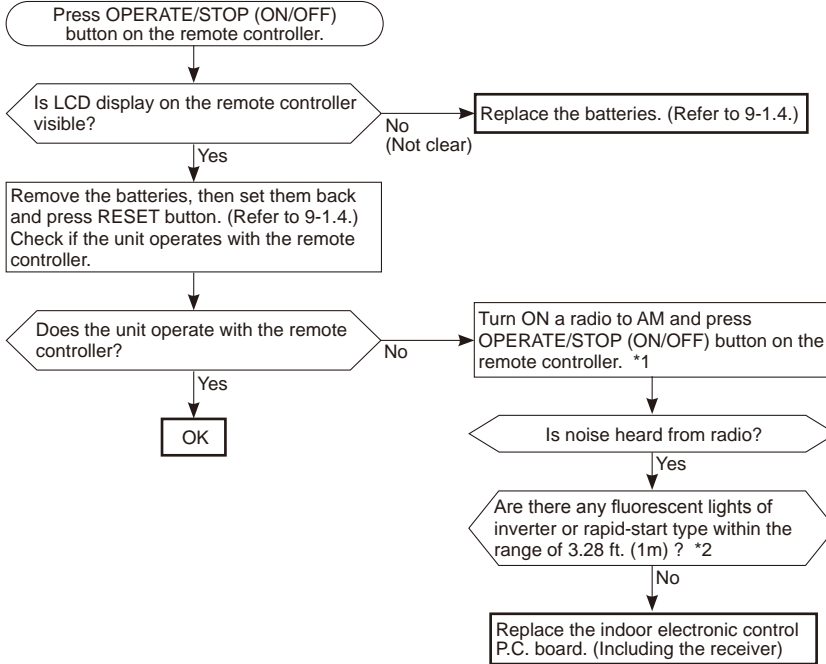

*1 Look at the image of the signal transmitting section of the remote controller through the monitor of a digital camera or a camera phone. It is normal if the LED of the signal transmitting section lights up when the OPERATE/STOP (ON/OFF) button on the remote controller is pressed. However, it may be difficult to see the illuminated LED of the signal transmitting section with a smartphone camera.

*2 If the inverter fluorescent light is turned on when the room is cool, the unit may have difficulty receiving the signal from the remote controller or may not be able to operate with it; if the inverter fluorescent light is turned on when the room is warm, the unit may be able to operate with the remote controller.

MSZ-HE24NA

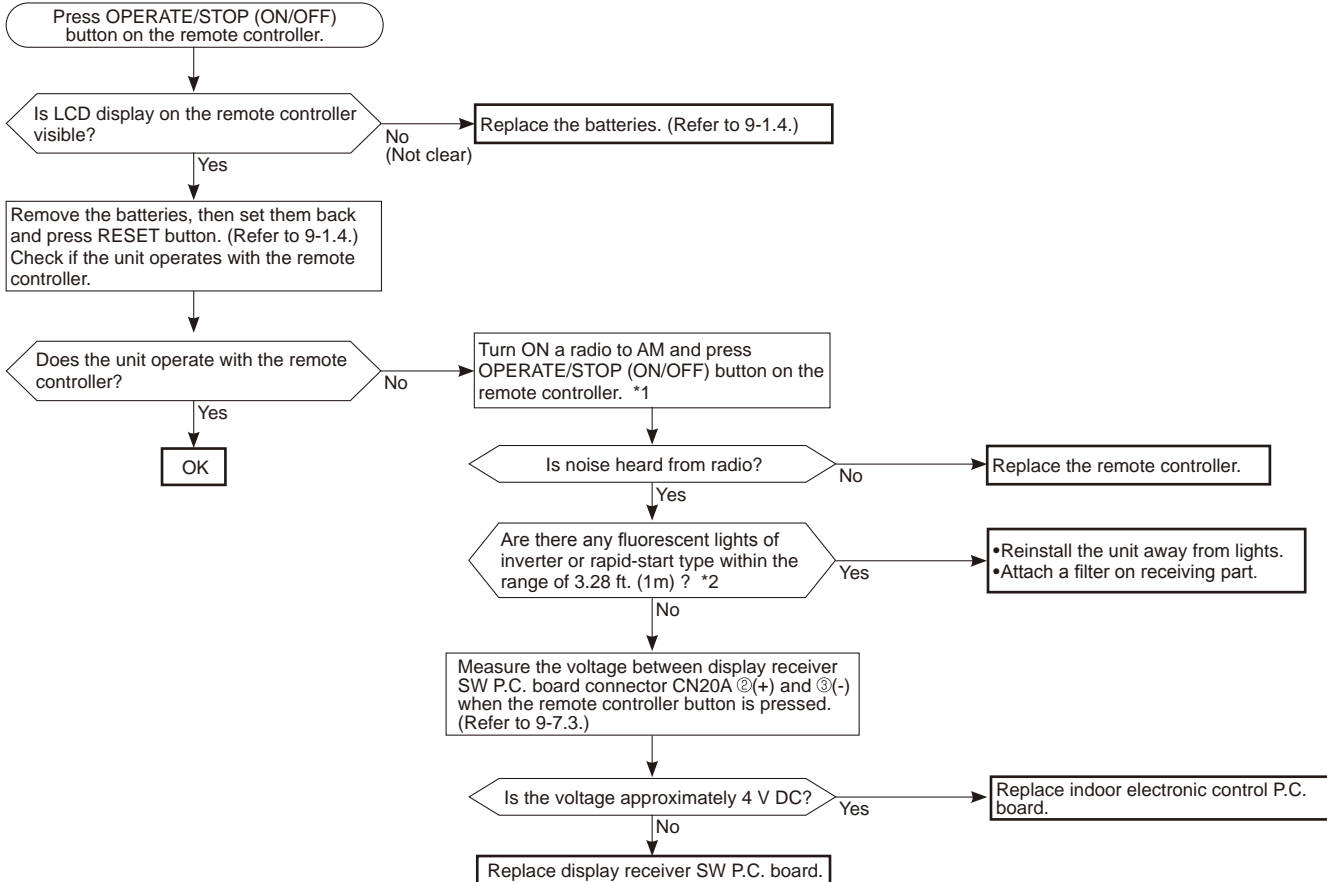

© Check of indoor P.C. board and indoor fan motor

MSZ-HE09/12/15/18NA

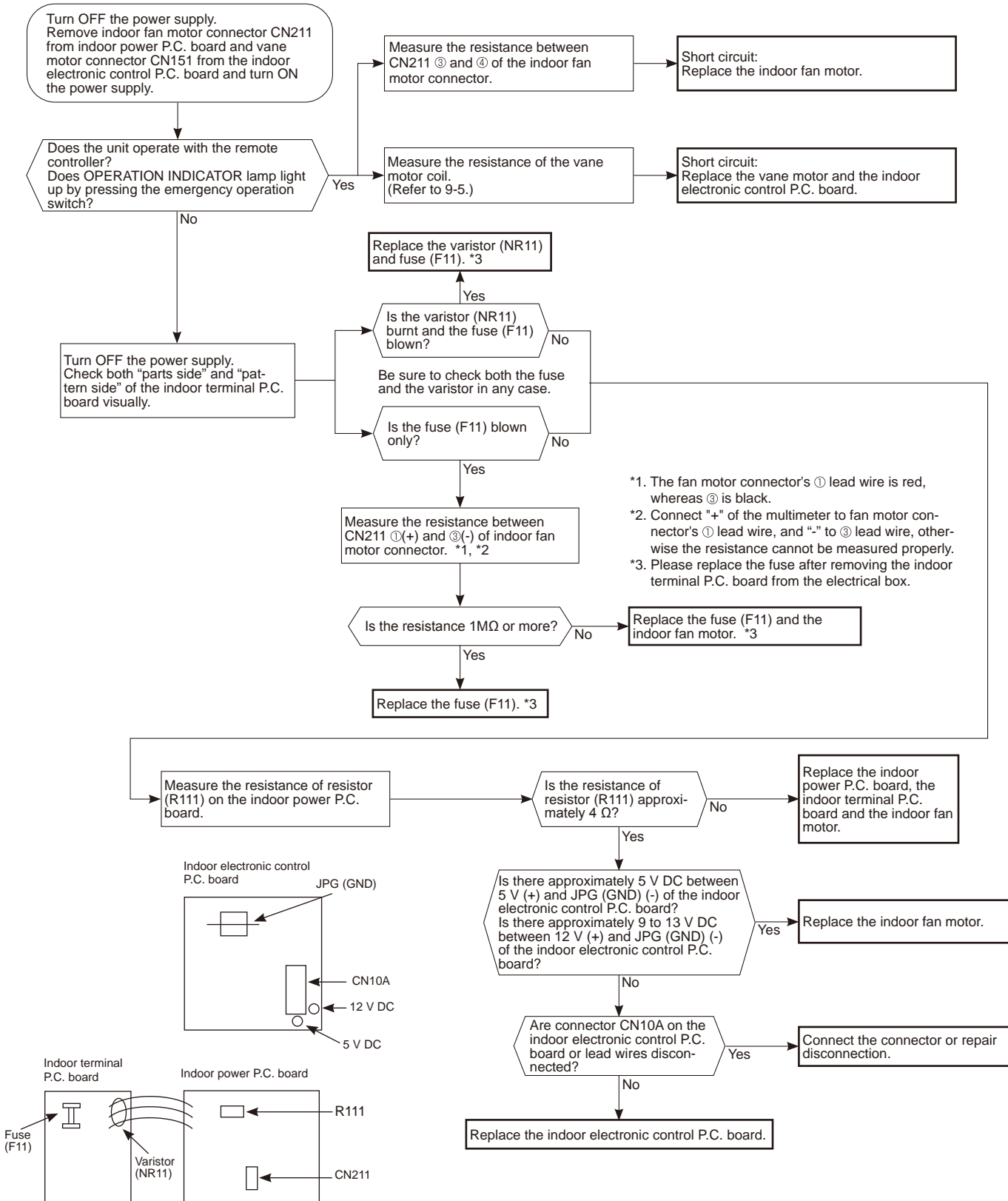

*1. The fan motor connector's ① lead wire is red, whereas ③ is black.
*2. Connect "+" of the multimeter to fan motor connector's ① lead wire, and "-" to ③ lead wire, otherwise the resistance cannot be measured properly.
*3. Please replace the fuse after removing the indoor terminal P.C. board from the electrical box.

MSZ-HE24NA

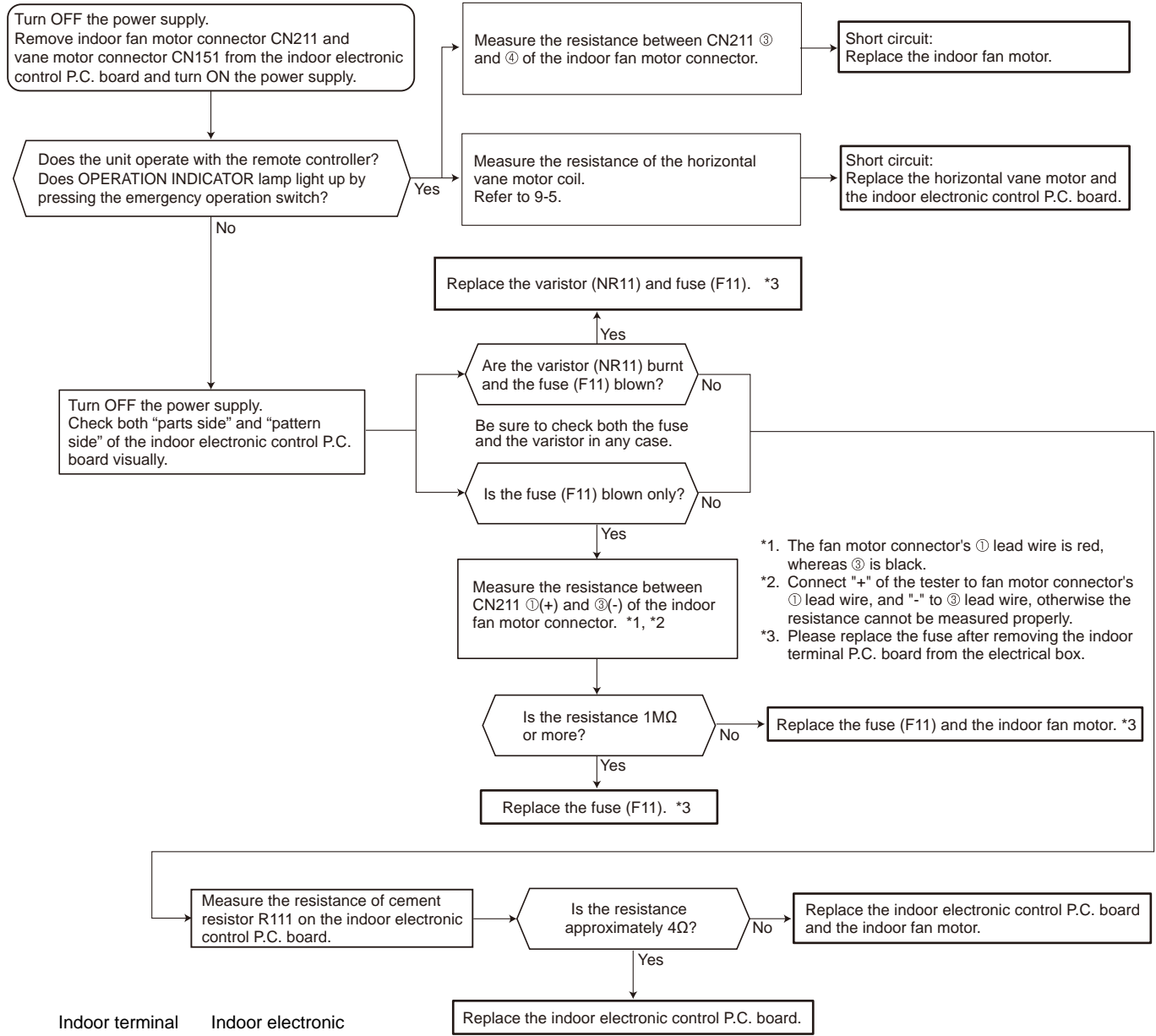

- *1. The fan motor connector's ① lead wire is red, whereas ③ is black.
- *2. Connect "+" of the tester to fan motor connector's ① lead wire, and "-" to ③ lead wire, otherwise the resistance cannot be measured properly.
- *3. Please replace the fuse after removing the indoor terminal P.C. board from the electrical box.

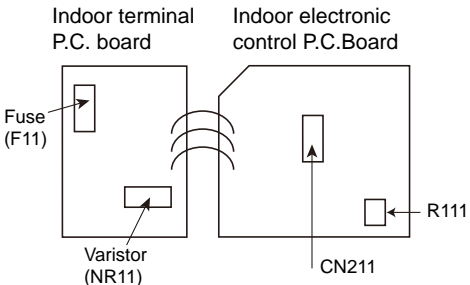

D How to check miswiring and serial signal error

MSZ-HE09/12/15/18NA

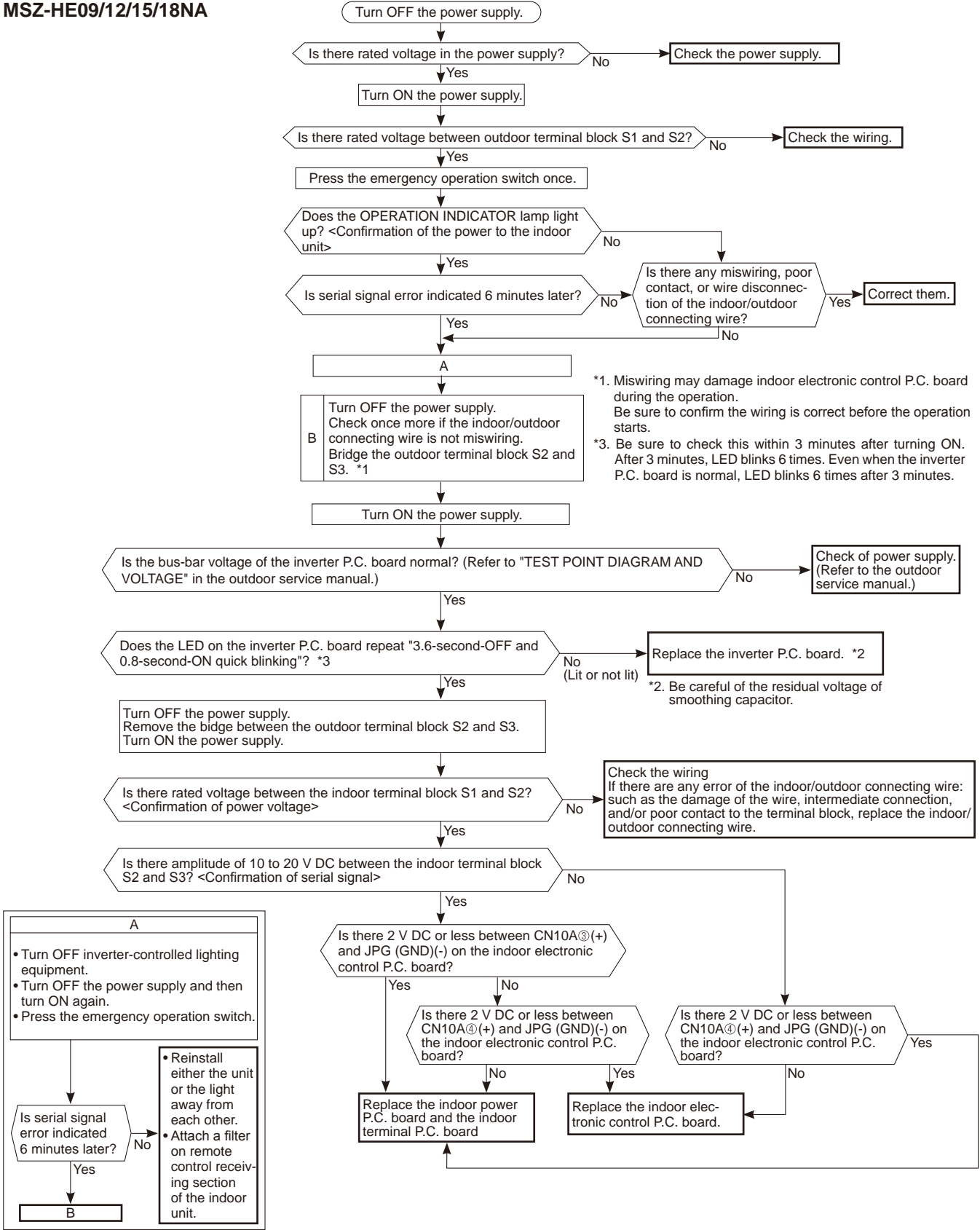

*1. Miswiring may damage indoor electronic control P.C. board during the operation. Be sure to confirm the wiring is correct before the operation starts.
 *2. Be careful of the residual voltage of smoothing capacitor.
 *3. Be sure to check this within 3 minutes after turning ON. After 3 minutes, LED blinks 6 times. Even when the inverter P.C. board is normal, LED blinks 6 times after 3 minutes.

A

- Turn OFF inverter-controlled lighting equipment.
- Turn OFF the power supply and then turn ON again.
- Press the emergency operation switch.

↓

Is serial signal error indicated 6 minutes later?

Yes → **B**

No →

- Reinstall either the unit or the light away from each other.
- Attach a filter on remote control receiving section of the indoor unit.

MSZ-HE24NA

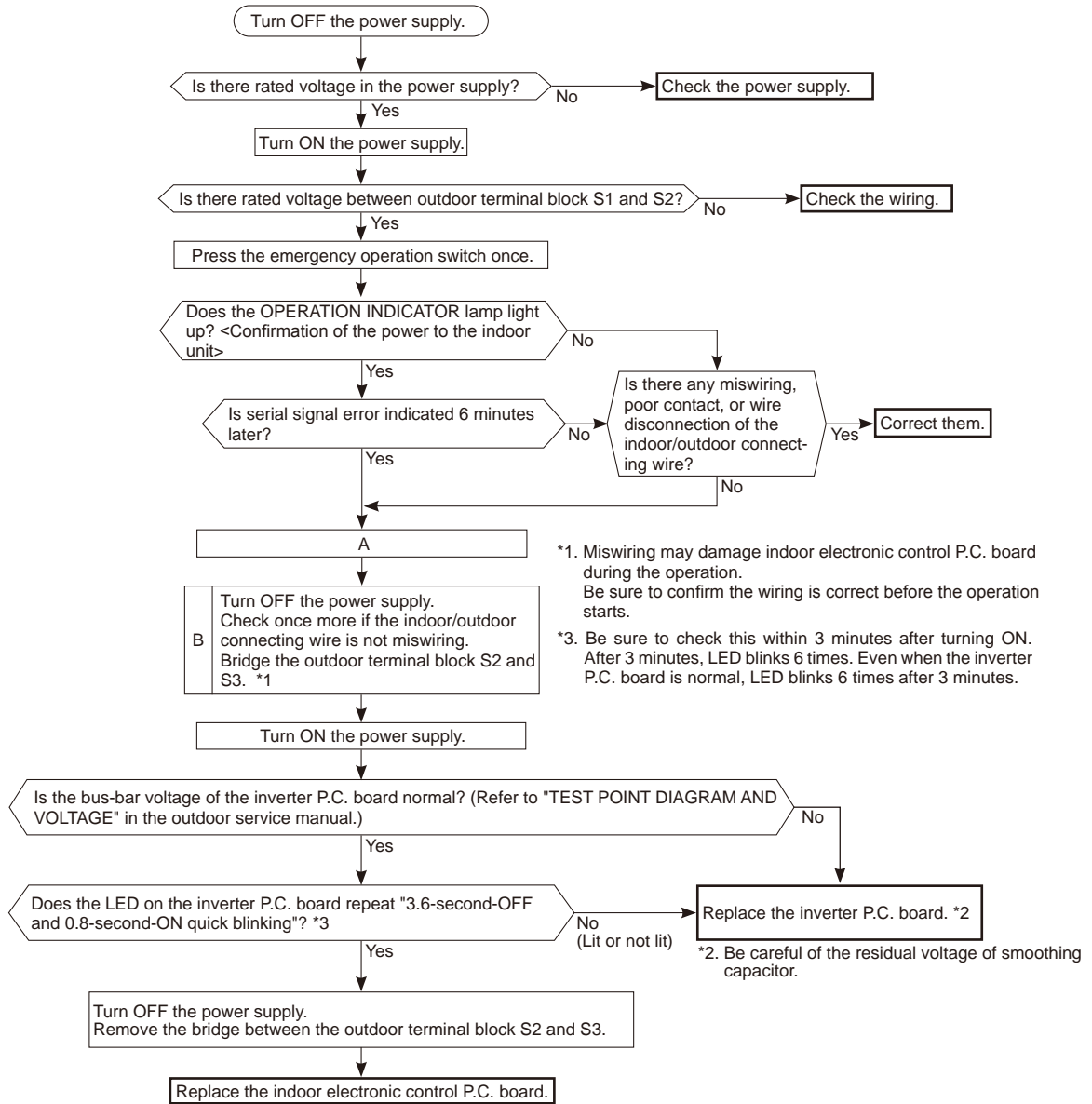

*1. Miswiring may damage indoor electronic control P.C. board during the operation. Be sure to confirm the wiring is correct before the operation starts.

*3. Be sure to check this within 3 minutes after turning ON. After 3 minutes, LED blinks 6 times. Even when the inverter P.C. board is normal, LED blinks 6 times after 3 minutes.

*2. Be careful of the residual voltage of smoothing capacitor.

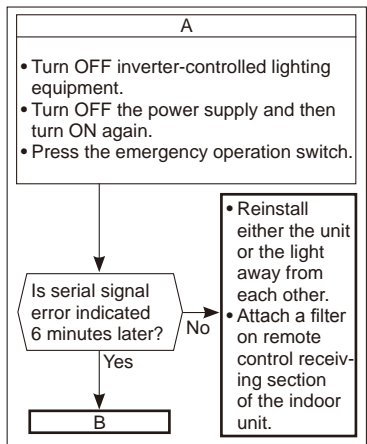

E Electromagnetic noise enters into TV sets or radios

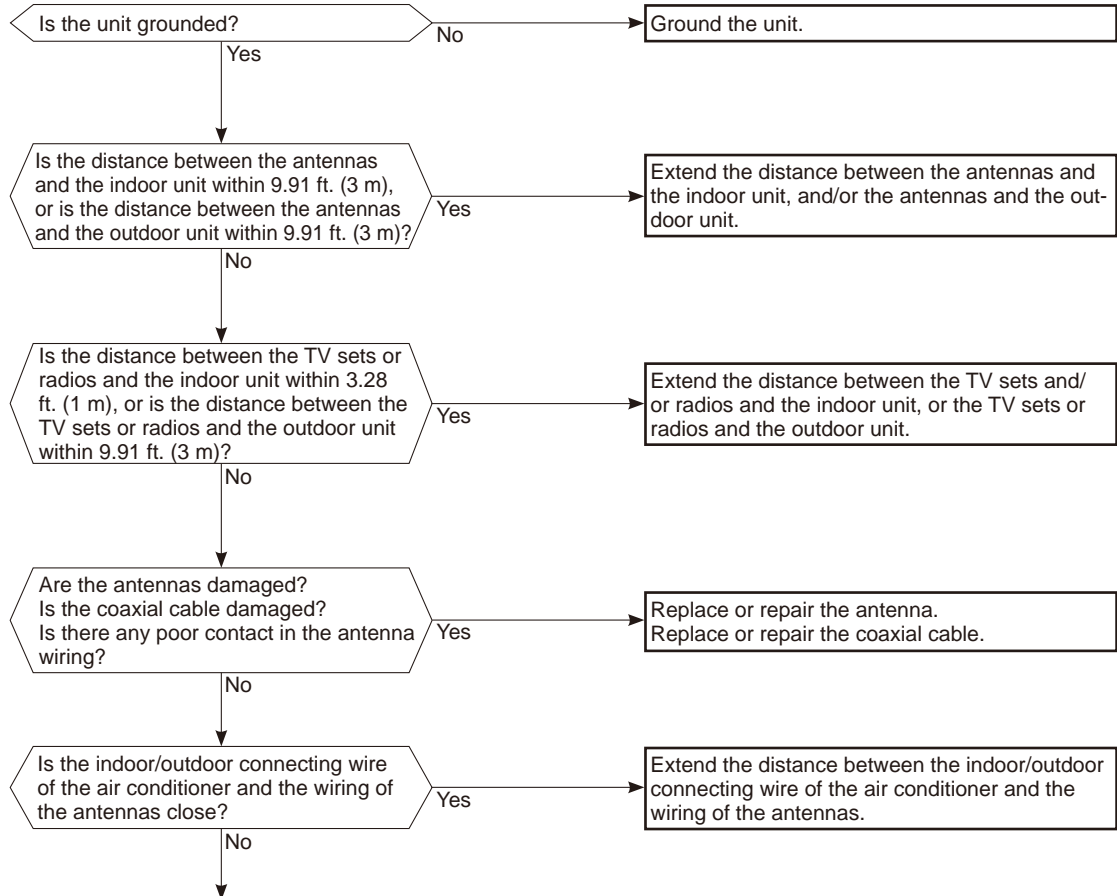

Even if all of the above conditions are fulfilled, the electromagnetic noise may enter, depending on the electric field strength or the installation condition (combination of specific conditions such as antennas or wiring). Check the followings before asking for service.

1. Devices affected by the electromagnetic noise
TV sets, radios (FM/AM broadcast, shortwave)
2. Channel, frequency, broadcast station affected by the electromagnetic noise
3. Channel, frequency, broadcast station unaffected by the electromagnetic noise
4. Layout of:
indoor/outdoor unit of the air conditioner, indoor/outdoor wiring, grounding wire, antennas, wiring from antennas, receiver
5. Electric field intensity of the broadcast station affected by the electromagnetic noise
6. Presence or absence of amplifier such as booster
7. Operation condition of air conditioner when the electromagnetic noise enters in
 - 1) Turn OFF the power supply once, and then turn ON the power supply. In this situation, check for the electromagnetic noise.
 - 2) Within 3 minutes after turning ON the power supply, press OPERATE/STOP (ON/OFF) button on the remote controller for power ON, and check for the electromagnetic noise.
 - 3) After a short time (3 minutes later after turning ON), the outdoor unit starts running. During operation, check for the electromagnetic noise.
 - 4) Press OPERATE/STOP (ON/OFF) button on the remote controller for power OFF, when the outdoor unit stops but the indoor/outdoor communication still runs on. In this situation, check for the electromagnetic noise.

9-7. TEST POINT DIAGRAM AND VOLTAGE

1. Indoor power P.C. board, Indoor terminal P.C. board

MSZ-HE09NA MSZ-HE12NA MSZ-HE15NA MSZ-HE18NA

Indoor terminal P.C. board

Indoor power P.C. board

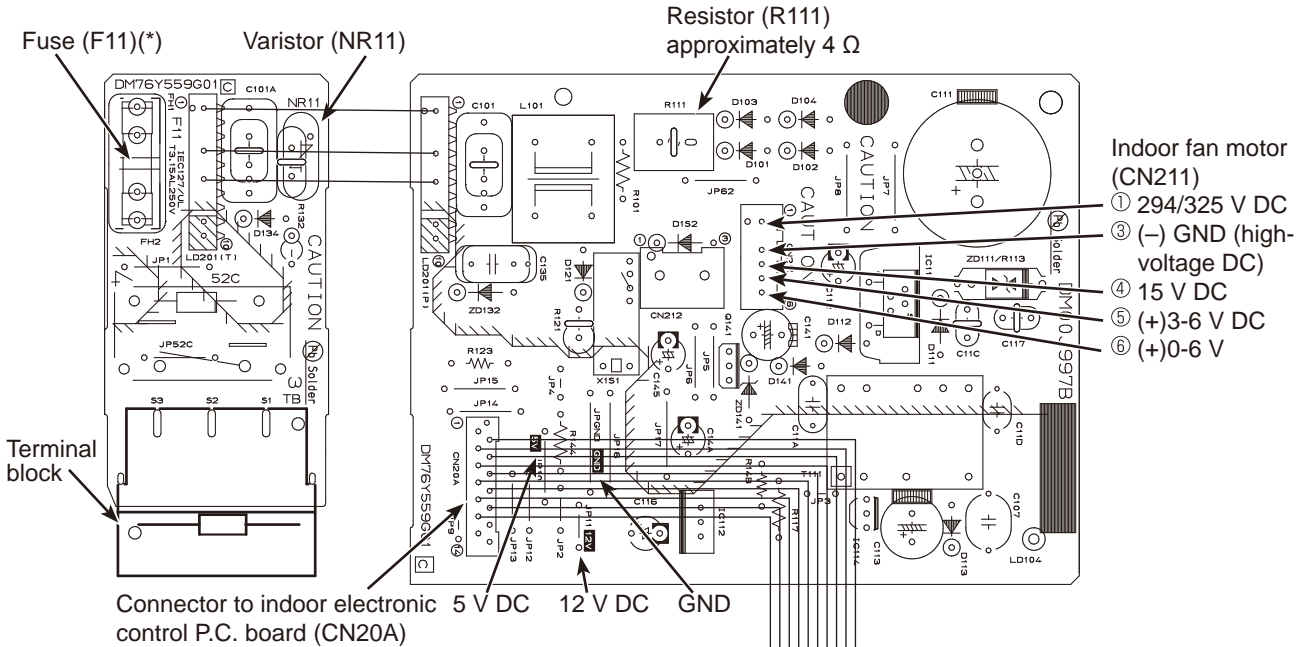

* Please replace the fuse after removing the indoor terminal P.C. board from the electrical box.

2. Indoor electronic control P.C. board

MSZ-HE09NA MSZ-HE12NA MSZ-HE15NA MSZ-HE18NA

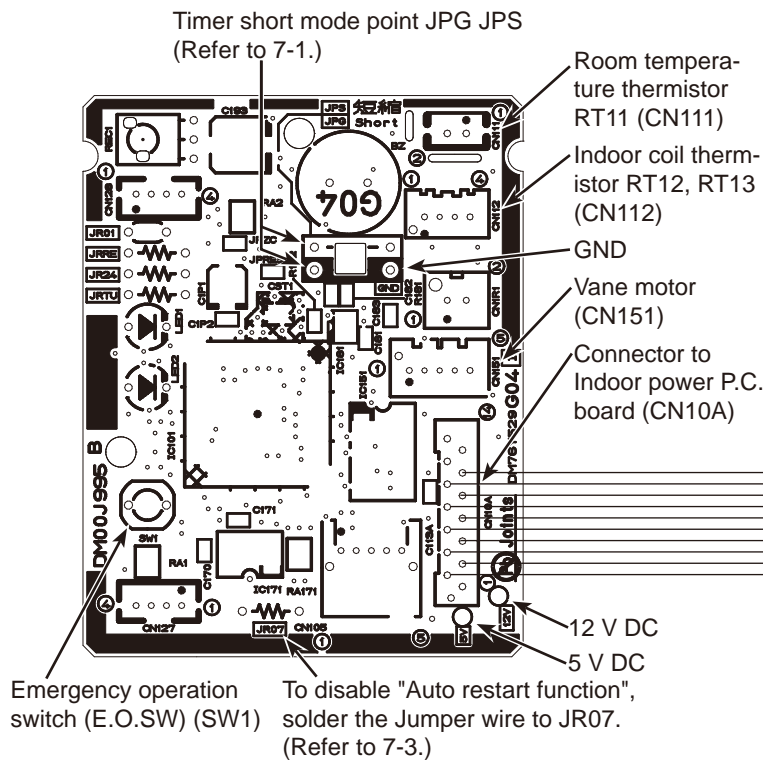

Room temperature thermistor (RT11)
Indoor coil thermistor (RT12, RT13)

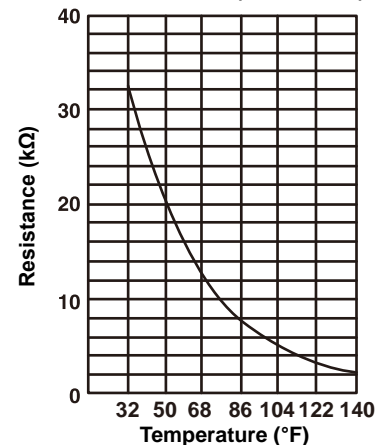

3. Indoor terminal P.C. board, Indoor electronic control P.C. board, Display receiver SW P.C. board MSZ-HE24NA

Indoor terminal P.C. board

Fuse (F11)(*)
Terminal block
Varistor (NR11)

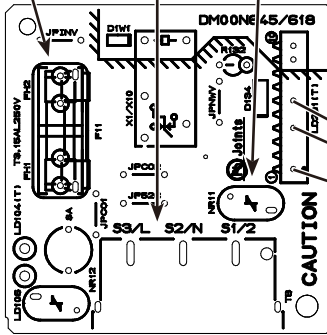

Indoor electronic control P.C. board

Indoor coil thermistor
RT12, RT13
(CN112)

To disable "Auto restart function",
solder the Jumper wire to JR07.
(Refer to 7-3.)

Resistor (R111)
approximately 4 Ω

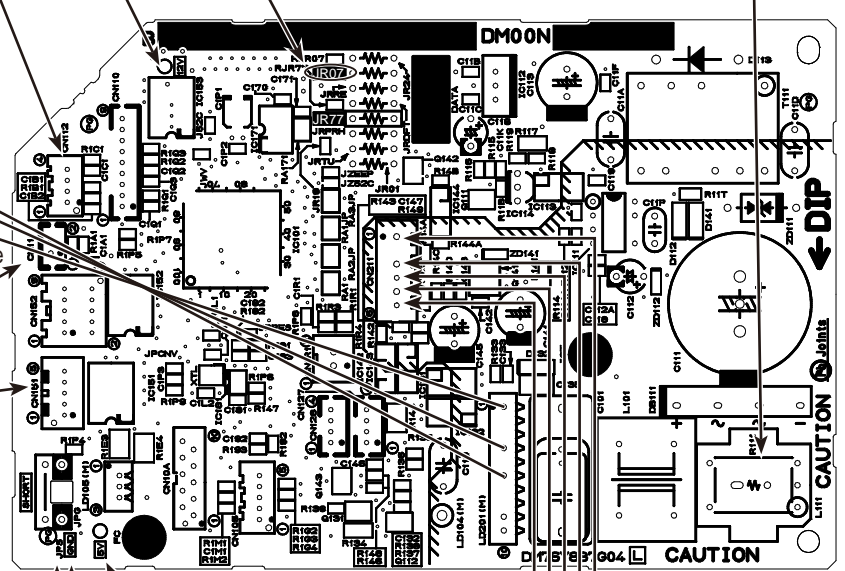

Display receiver SW P.C. board

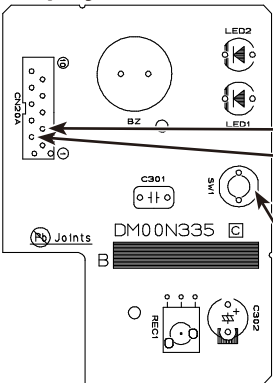

Room temperature
thermistor RT11
(CN111)

Vane motor
(CN151)

CN20A
③ (-)
② (+)
(Refer to 9-6. ㊸.)

Emergency
operation switch
(E.O. SW)
(SW1)

5 V DC
Timer short mode point
JPG JPS (Refer to 7-1.)

In indoor fan motor
(CN211)
① 294/325 V DC
③ (-) GND
(high-voltage DC)
④ 15 V DC
⑤ (+) 3-6 V DC
⑥ (+) 0 or 15 V DC

* Please replace the fuse after removing the indoor terminal P.C. board from the electrical box.

Room temperature thermistor (RT11)
Indoor coil thermistor (RT12, RT13)

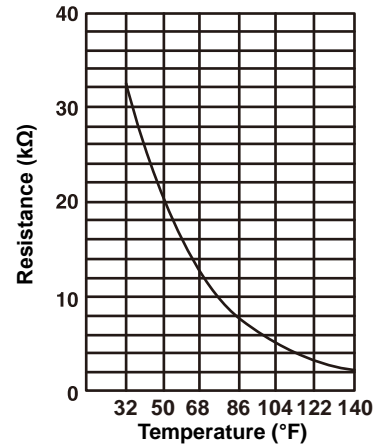

<Detaching method of the terminal with locking mechanism>

The terminal which has the locking mechanism can be detached as shown below.

There are 2 types of the terminal with locking mechanism.

The terminal without locking mechanism can be detached by pulling it out.

Check the shape of the terminal before detaching.

(1) Slide the sleeve and check if there is a locking lever or not.

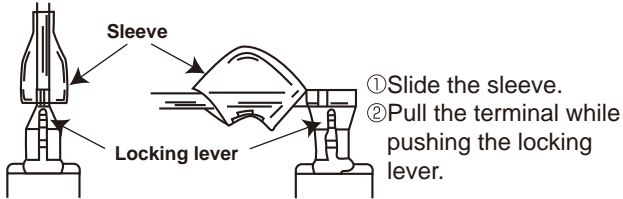

(2) The terminal with this connector shown below has the locking mechanism.

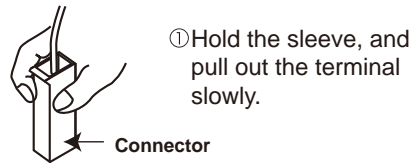

→ : Indicates the visible parts in the photos/figures.
 ----> : Indicates the invisible parts in the photos/figures.

10-1. MSZ-HE09NA MSZ-HE12NA MSZ-HE15NA MSZ-HE18NA

NOTE: Turn OFF power supply before disassembly.

| OPERATING PROCEDURE | PHOTOS/FIGURES |
|---|-----------------------|
| <p>1. Removing the panel</p> <p>(1) Remove the horizontal vanes.</p> <p>(2) Remove the screw caps of the panel. Remove the screws of the panel.</p> <p>(3) Unhook the lower part (A) of the panel.</p> <p>(4) Hold the lower part of both ends of the panel and pull it slightly toward you, and then remove the panel by pushing it upward.</p> | <p>Photo 1</p> |

OPERATING PROCEDURE

2. Removing the indoor electronic control P.C. board and the room temperature thermistor

- (1) Remove the panel (Refer to section 1.) and the corner box.
- (2) Remove the screw of the V.A. clamp and the V.A. clamp.
- (3) Remove the screw of the electrical cover and the electrical cover.
- (4) Remove the screw of conduit cover and the conduit cover.
- (5) Remove the screw of conduit plate, the conduit plate and the indoor/outdoor connecting wire.
- (6) Open the indoor electronic control P.C. board holder (to right side)
- (7) Disconnect the following connectors:
<Indoor electronic control P.C. board>
CN112 (Indoor coil thermistor)
CN151 (Vane motor)
CN10A (To the indoor power P.C. board)
- (8) Unhook the catches of the indoor electronic control P.C. board holder from the nozzle and the electrical box (right side).
- (9) Remove the room temperature thermistor from the hook of the indoor electronic control P.C. board holder.
- (10) Open the back side of the indoor electronic control P.C. board holder, and remove the indoor electronic control P.C. board.
- (11) Remove the room temperature thermistor from the indoor electronic control P.C. board.

3. Remove the indoor power P.C. board, the indoor terminal P.C. board, and the electrical box

- (1) Remove the panel (Refer to section 1.) and the corner box.
- (2) Remove the indoor/outdoor connecting wire (Refer to section 2 (2)-(5).).
- (3) Remove the ground wire connected to the indoor heat exchanger from the electrical box.
- (4) Unhook first the lower, then the upper catches of the electrical box, and pull out the electrical box.
- (5) Disconnect all the connectors on the indoor power P.C. board and unhook all lead wires.
- (6) Remove the screw of terminal block on the indoor terminal P.C. board.
- (7) Remove the indoor power P.C. board and the indoor terminal P.C. board.

PHOTOS/FIGURES

Photo 2

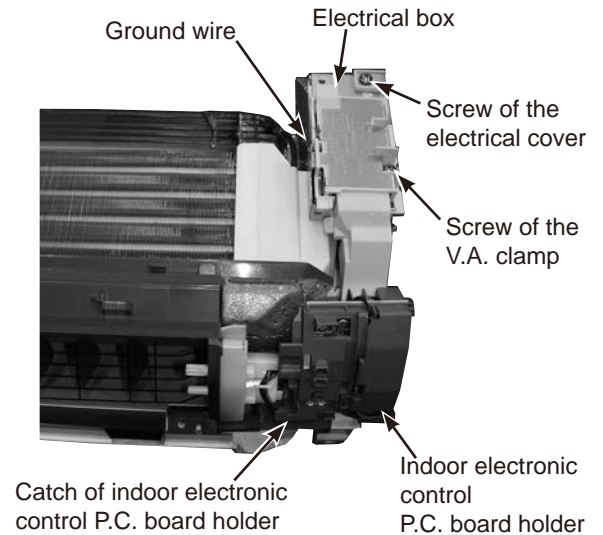
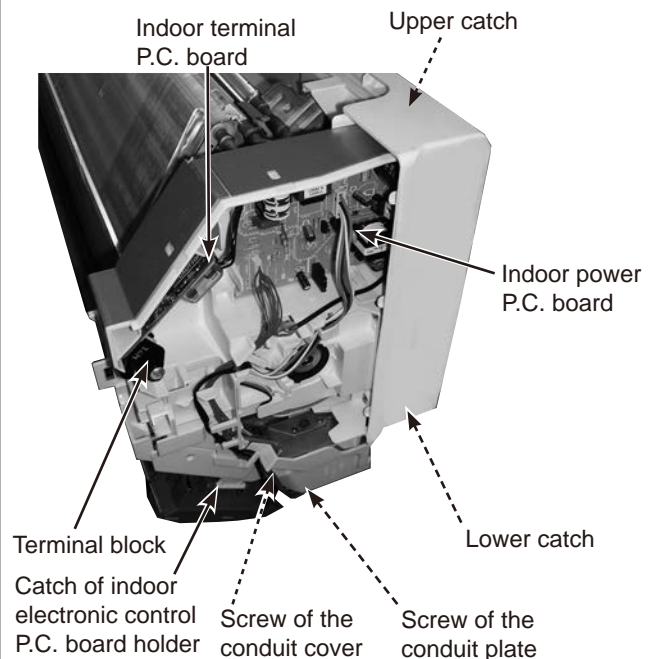
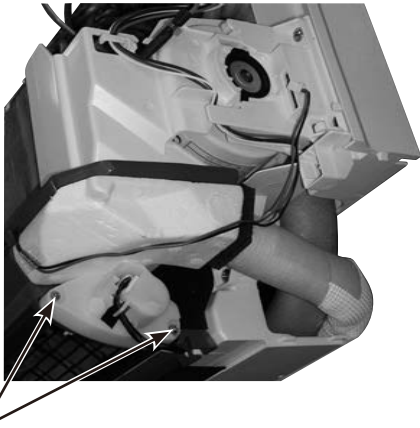

Photo 3





| OPERATING PROCEDURE | PHOTOS/FIGURES |
|---|--|
| <p>4. Removing the nozzle assembly</p> <ol style="list-style-type: none">(1) Remove the panel (Refer to section 1.) and the corner box.(2) Remove the indoor/outdoor connecting wire (Refer to section 2 (2)-(5).).(3) Remove the indoor electronic control P.C. board holder.(4) Pull out the drain hose from the nozzle assembly and remove the nozzle assembly. | <p>Photo 4</p>  |
| <p>5. Removing the horizontal vane motor</p> <ol style="list-style-type: none">(1) Remove the nozzle assembly. (Refer to section 4.)(2) Remove the screws of the horizontal vane motor unit.(3) Disconnect the connector from the horizontal vane motor.(4) Remove the screws of the horizontal vane motor.(5) Remove the horizontal vane motor from the horizontal vane motor unit. | <p>Screws of horizontal vane motor unit</p> |

OPERATING PROCEDURE

6. Removing the indoor fan motor, the indoor coil thermistor, and the line flow fan

- (1) Remove the panel (Refer to section 1.) and the corner box.
- (2) Remove the indoor electronic control P.C. board holder, the electrical box and the nozzle assembly.
- (3) Remove the screws fixing the motor bed.
- (4) Loosen the screw fixing the line flow fan.
- (5) Remove the motor bed together with the fan motor and the motor band.
- (6) Release the hooks of the motor band. Remove the motor band. Pull out the indoor fan motor.
- (7) Remove the indoor coil thermistor from the heat exchanger.
* Install the indoor coil thermistor in its former position when assembling it. (Photo 8)
- (8) Remove the screws fixing the left side of the heat exchanger.
- (9) Lift the heat exchanger, and pull out the line flow fan to the lower-left.

Photo 8

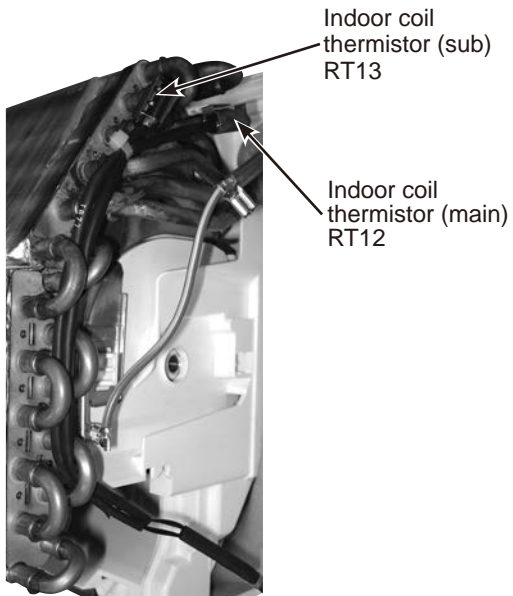

PHOTOS/FIGURES

Photo 5

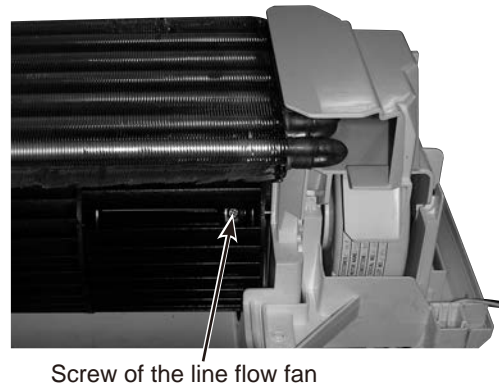

Photo 6

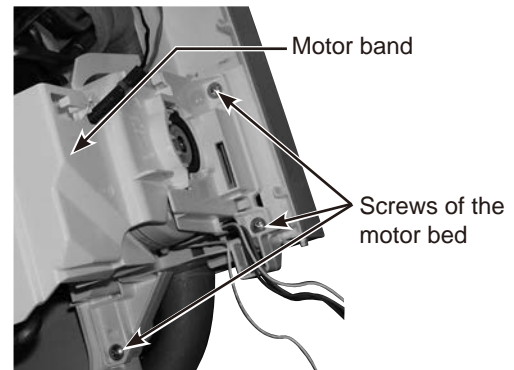
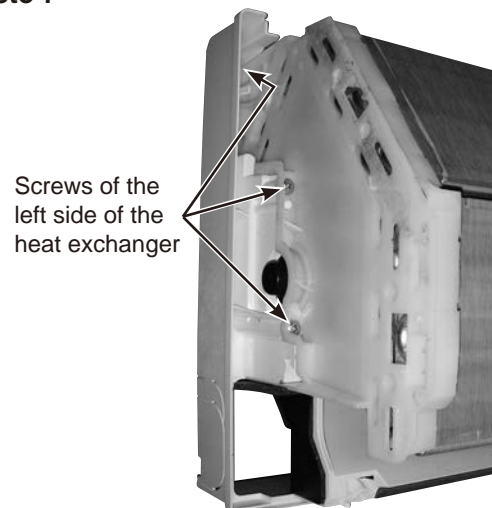
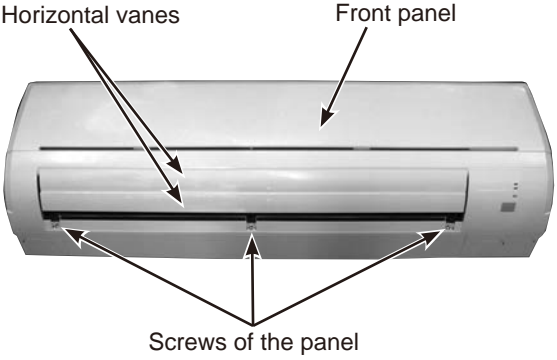
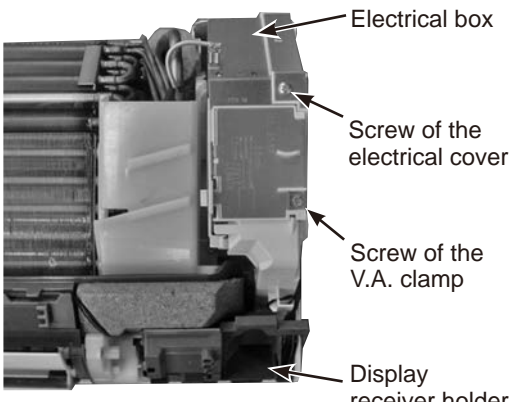
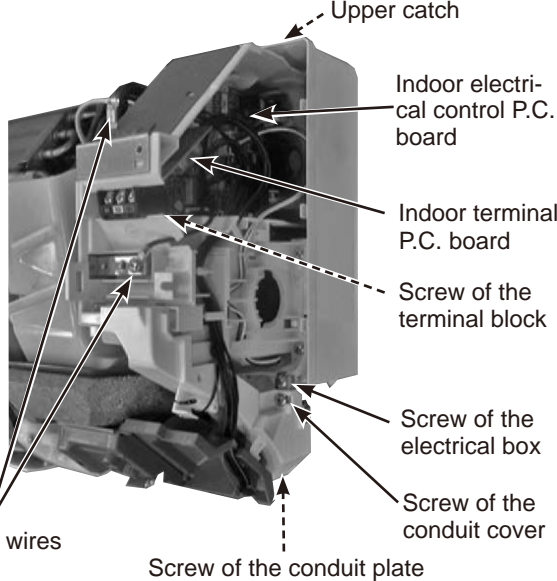

Photo 7



10-2. MSZ-HE24NA

NOTE: Turn OFF power supply before disassembly.

| OPERATING PROCEDURE | PHOTOS/FIGURES |
|---|---|
| <p>1. Removing the panel</p> <ol style="list-style-type: none">(1) Remove the horizontal vanes.(2) Remove the screw caps of the panel. Remove the screws of the panel.(3) Hold the lower part of both ends of the panel and pull it slightly toward you, and then remove the panel by pushing it upward. | <p>Photo 1</p>  <p>Horizontal vanes</p> <p>Front panel</p> <p>Screws of the panel</p> |
| <p>2. Removing the indoor electronic control P.C. board, the display receiver SW P.C. board and the indoor terminal P.C. board</p> <ol style="list-style-type: none">(1) Remove the panel (Refer to section 1.) and the corner box.(2) Remove the screw of the V.A. clamp and the V.A. clamp.(3) Remove the screw of the conduit cover and the conduit cover.(4) Remove the screw of the conduit plate, the conduit plate and the indoor/outdoor connecting wire.(5) Remove the screw of the electrical cover, and then the electrical cover.(6) Remove the ground wire connected to the indoor electronic control P.C. board from the electrical box. (Photo 3)(7) Remove the display receiver holder.(8) Open the rear cover of the display receiver holder and pull out the display receiver SW P.C. board.(9) Disconnect all the connectors on the indoor electronic control P.C. board and unhook all lead wires.(10) Remove the screw of the terminal block on the indoor terminal P.C. board.(11) Remove the indoor terminal P.C. board and the indoor electronic control P.C. board. | <p>Photo 2</p>  <p>Electrical box</p> <p>Screw of the electrical cover</p> <p>Screw of the V.A. clamp</p> <p>Display receiver holder</p> |
| <p>3. Removing the indoor electrical box</p> <ol style="list-style-type: none">(1) Remove the panel (Refer to section 1.) and the corner box.(2) Remove the indoor/outdoor connecting wire. (Refer to section 2 (2)-(4).)(3) Remove the ground wire connected to the indoor heat exchanger from the electrical box.(4) Remove the screw of the electrical cover and remove the electrical cover.(5) Disconnect all the connectors on the indoor electronic control P.C. board and unhook all lead wires.(6) Remove the screw fixing the electrical box, then the upper catch of the electrical box, and pull out the electrical box. | <p>Photo 3</p>  <p>Upper catch</p> <p>Indoor electrical control P.C. board</p> <p>Indoor terminal P.C. board</p> <p>Screw of the terminal block</p> <p>Screw of the electrical box</p> <p>Screw of the conduit cover</p> <p>Screw of the conduit plate</p> <p>Ground wires</p> |



OPERATING PROCEDURE

4. Removing the nozzle assembly

- (1) Remove the panel (Refer to section 1.) and the corner box.
- (2) Remove the V.A. clamp, and then the indoor/outdoor connecting wire. (Refer to section 2 (2)-(4).)
- (3) Remove the electrical cover. (Photo 2)
- (4) Disconnect the following connectors on the electronic control P.C. board:
CN151 (Horizontal vane motor)
- (5) Remove the display receiver holder. (Photo 2)
- (6) Pull out the drain hose from the nozzle assembly and remove the nozzle assembly.
- (7) Remove the vane motors. (Refer to section 5.)

5. Removing the horizontal vane motor

- (1) Remove the nozzle assembly. (Refer to section 4.)
- (2) Remove the screws of the horizontal vane motor unit, and pull out the horizontal vane motor unit.
- (3) Disconnect the connector from the horizontal vane motor.
- (4) Remove the screws of the horizontal vane motor unit cover.
- (5) Remove the horizontal vane motor from the horizontal vane motor unit.

PHOTOS/FIGURES

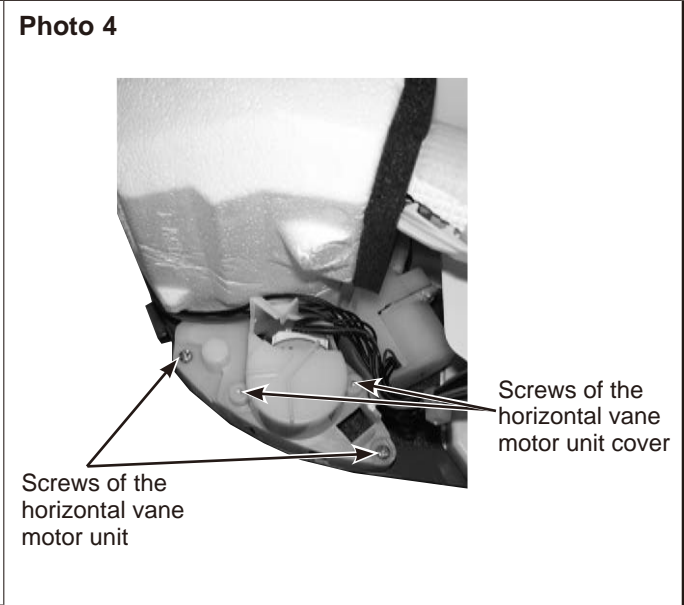

OPERATING PROCEDURE

6. Removing the water cut, the indoor fan motor, the indoor coil thermistor, and the line flow fan

- (1) Remove the panel (Refer to section 1.) and the corner box.
- (2) Remove the display receiver holder, the electrical box and the nozzle assembly. (Refer to section 3 and 4.)
- (3) Remove the screw of the water cut and remove the water cut.
- (4) Remove the screws fixing the motor bed.
- (5) Loosen the screw fixing the line flow fan.
- (6) Remove the motor bed together with fan motor and motor band.
- (7) Remove the screw of the motor band.
- (8) Release the hooks of the motor band. Remove the motor band. Pull out the indoor fan motor.
- (9) Remove the indoor coil thermistor from the heat exchanger.
 - * Install the indoor coil thermistor in its former position when assembling it. (Photo 7)
- (10) Remove the screws fixing the left side of the heat exchanger.
- (11) Lift the heat exchanger, and pull out the line flow fan to the lower-left.

Photo 5

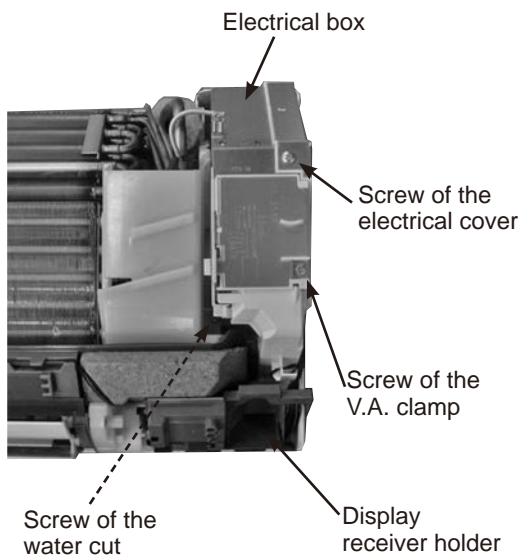

PHOTOS/FIGURES

Photo 6

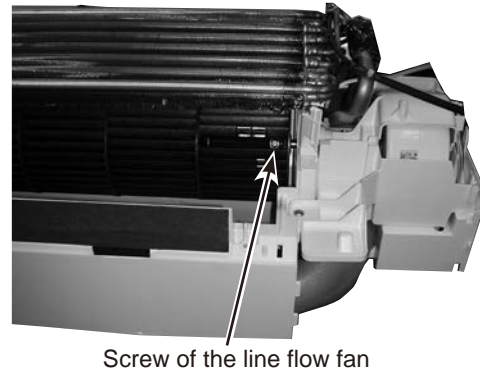

Photo 7

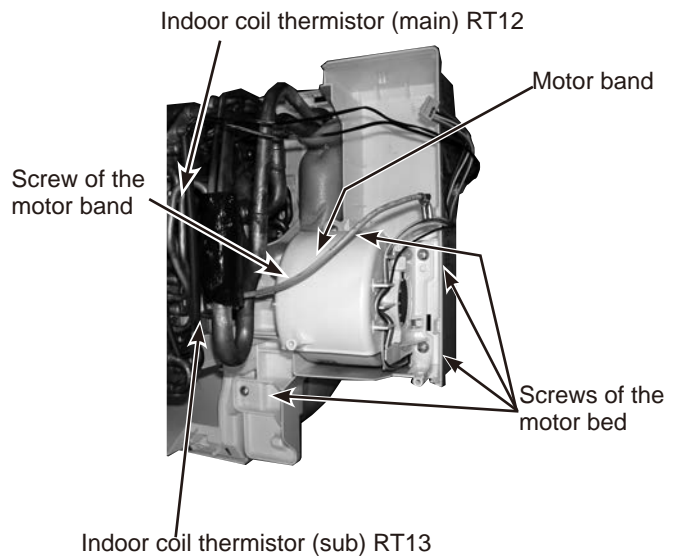
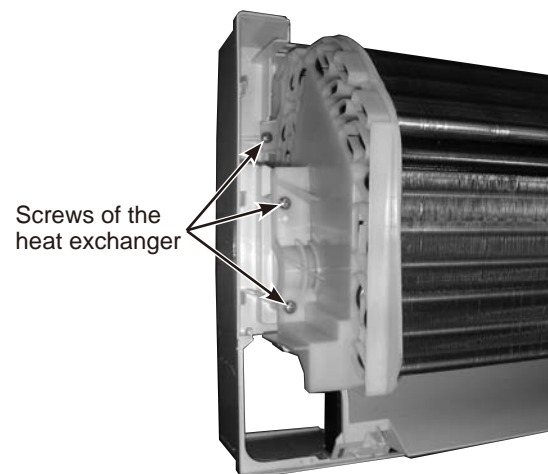

Photo 8



Fixing the indoor coil thermistor

* There are 2 forms of parts for fixing the indoor coil thermistor.

Clip shape



Holder shape



When fixing the indoor coil thermistor to the clip-shape/holder-shape part, the lead wire should point down.

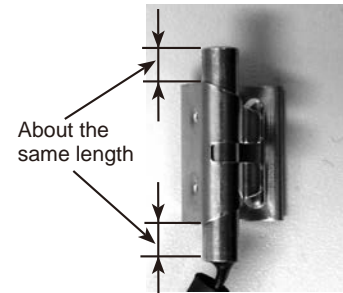

Position and procedure for mounting the clip-shape part

1. Set the indoor coil thermistor in the center of the clip-shape part.



2. Check the (marked) mounting position.



3. Mount the clip-shape part.



NOTE:

- Take care to avoid loss and accidental falling of the clip-shape part inside the unit.
- Mount the clip-shape part on the marked position.
- Do not pull the lead wire when removing the indoor coil thermistor.

mitsubishi electric corporation

HEAD OFFICE: TOKYO BUILDING, 2-7-3, MARUNOUCHI, CHIYODA-KU, TOKYO 100-8310, JAPAN

© Copyright 2014 MITSUBISHI ELECTRIC CORPORATION

Issued: Nov. 2021. No. OBH685 REVISED EDITION-B

Issued: Feb. 2016. No. OBH685 REVISED EDITION-A

Published: Feb. 2014. No. OBH685

Made in Japan

Specifications are subject to change without notice.