

Revision D:

- Indoor heat exchanger for MS-A09/12WA-□1 have been changed.

OB448 REVISED EDITION-C is void.

INDOOR UNIT SERVICE MANUAL

No. OB448
REVISED EDITION-D

Models

MS-A09WA

MS-A09WA - □1

MS-A12WA

MS-A12WA - □1

Outdoor unit service manual
MU-A•WA Series (OB449)

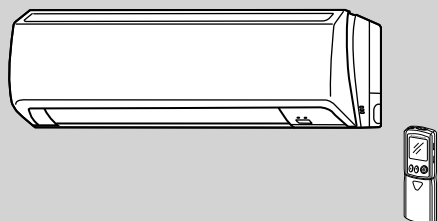

CONTENTS

1. TECHNICAL CHANGES	2
2. PART NAMES AND FUNCTIONS	3
3. SPECIFICATION	5
4. OUTLINES AND DIMENSIONS	6
5. WIRING DIAGRAM	7
6. REFRIGERANT SYSTEM DIAGRAM	7
7. SERVICE FUNCTIONS	8
8. TROUBLESHOOTING	9
9. DISASSEMBLY INSTRUCTIONS	21
10. PARTS LIST	24
10-1. PARTS LIST	24
10-2. RoHS PARTS LIST	27
11. MICROPROCESSOR CONTROL	30

NOTE:

RoHS compliant products have <G> mark on the spec name plate.
For servicing of RoHS compliant products, refer to the RoHS PARTS LIST (RoHS compliant).

Revision A :

- MS-A•WA- have been added.
Remote controller has been changed.

Revision B :

- SPECIFICATION has been corrected.
Powerful has been added. (Airflow ,Sound level)

Revision C:

- TEST POINT DIAGRAM AND VOLTAGE has been corrected. (8-7)

Revision D:

- Indoor heat exchanger for MS-A09/12WA- have been changed.

1**TECHNICAL CHANGES****MS09TW → MS-A09WA****MS12TN → MS-A12WA**

1. Indoor fan motor has been changed.
2. Signal of remote controller has been changed. (It is not available for conventional models.)

MS-A09WA → MS-A09WA -**MS-A12WA → MS-A12WA -**

1. Remote controller has been changed.
 - Temperature indication function (°F/°C) has been added. (Refer to 11-8.)

Models	Remote controller	Temperature indication
MS-A09/12WA	KM06C	°F
MS-A09/12WA-<input type="checkbox"/>	KM07L	°F/°C

- Timer indication has been changed. (AM/PM indication)
2. Conduit plate has been removed.
 3. Conduit cover, terminal block cover and terminal block holder have been changed.

2

PART NAMES AND FUNCTIONS

MS-A09WA
MS-A12WA

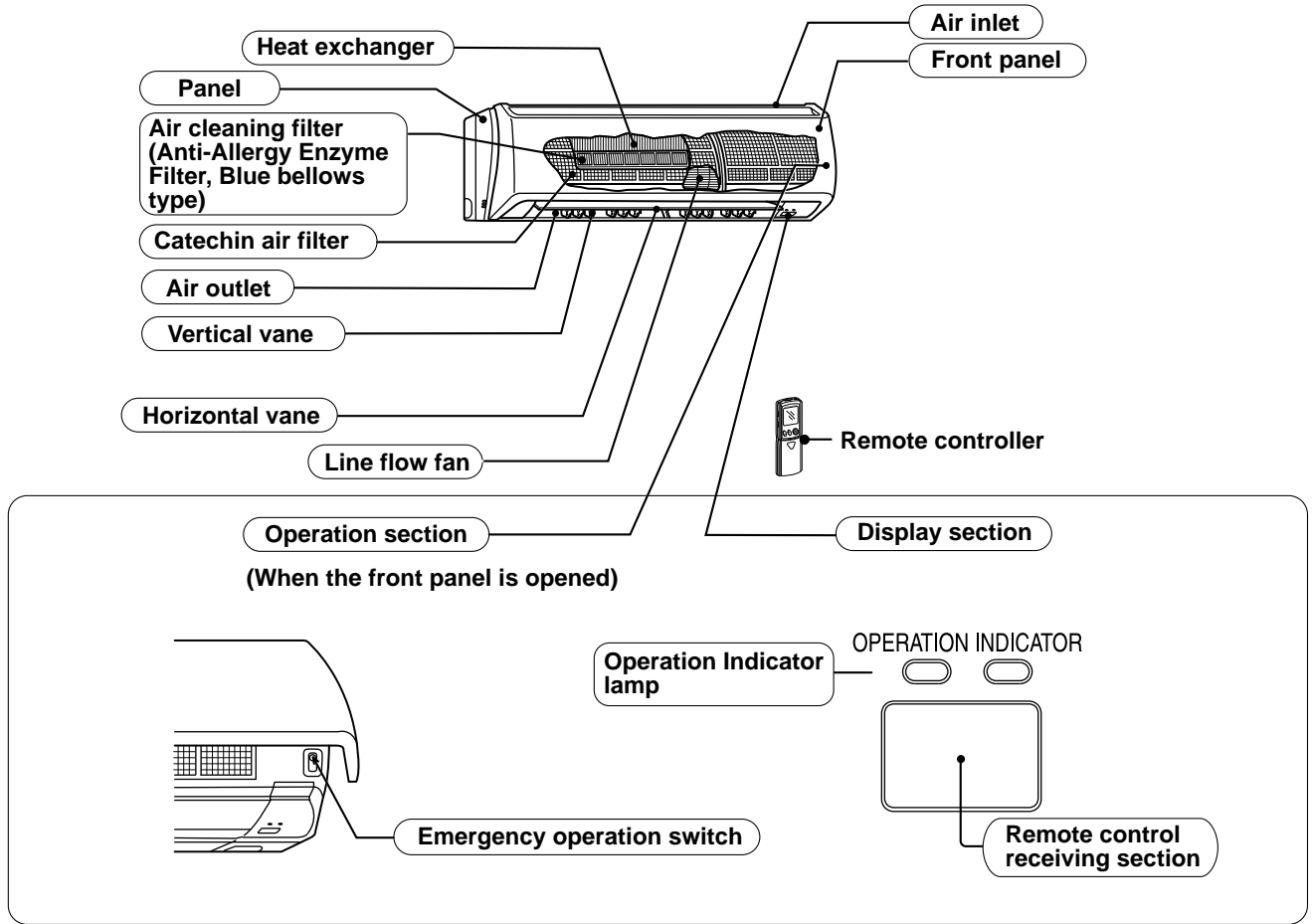

MS-A09WA
MS-A12WA

ACCESSORIES

		MS-A09/12WA	MS-A09/12WA-<input type="checkbox"/>1
①	Installation plate	1	1
②	Installation plate fixing screw 4 × 25 mm	8	5
③	Remote controller holder	1	1
④	Fixing screw for ③ 3.5 × 1.6 mm (Black)	2	2
⑤	Battery (AAA) for remote controller	2	2
⑥	Wireless remote controller	1	1
⑦	Felt tape (Used for left or left-rear piping)	1	1
⑧	Conduit plate	1	—

3

SPECIFICATION

Model		MS-A09WA		MS-A12WA	
Indoor unit model		MS-A09WA		MS-A12WA	
External finish		White			
Power supply	V, phase, Hz	115, 1, 60			
Max.-fuse size (time delay) / Disconnect switch	A	15			
Min. circuit ampacity	A	1.2			
Fan motor	F.L.A	0.95			
Airflow Low-Med.-High-Powerful	COOL Dry (Wet)	CFM	183 - 261 - 335 - 367 (162 - 233 - 300 - 328)	222 - 286 - 406 - 446 (198 - 254 - 363 - 399)	
Moisture removal		pt./h	2.7	3.2	
Sound level Low-Med.-High-Powerful		dB(A)	26 - 32 - 40 - 42	33 - 38 - 45 - 47	
Cond. drain connection O.D.		in.	5/8		
Dimensions	W	in.	30-11/16		
	D		8-1/4		
	H		11/-3/4		
Weight		lb.	23		
Remote controller		Wireless type			
Control voltage (by built-in transformer)		115 VAC			

NOTE : Test conditions are based on ARI 210/240

*1 : Rating conditions (cooling) — Indoor : 80°FDB, 67°F WB, Outdoor : 95°FDB, (75°F WB) Rated frequency : 60Hz

Operating Range

		Indoor intake air temperature	Outdoor intake air temperature
Cooling	Maximum	95°FDB, 71°F WB	115°FDB
	Minimum	67°FDB, 57°F WB	67°FDB

4

OUTLINES AND DIMENSIONS

MS-A09WA
MS-A12WA

Unit : inch

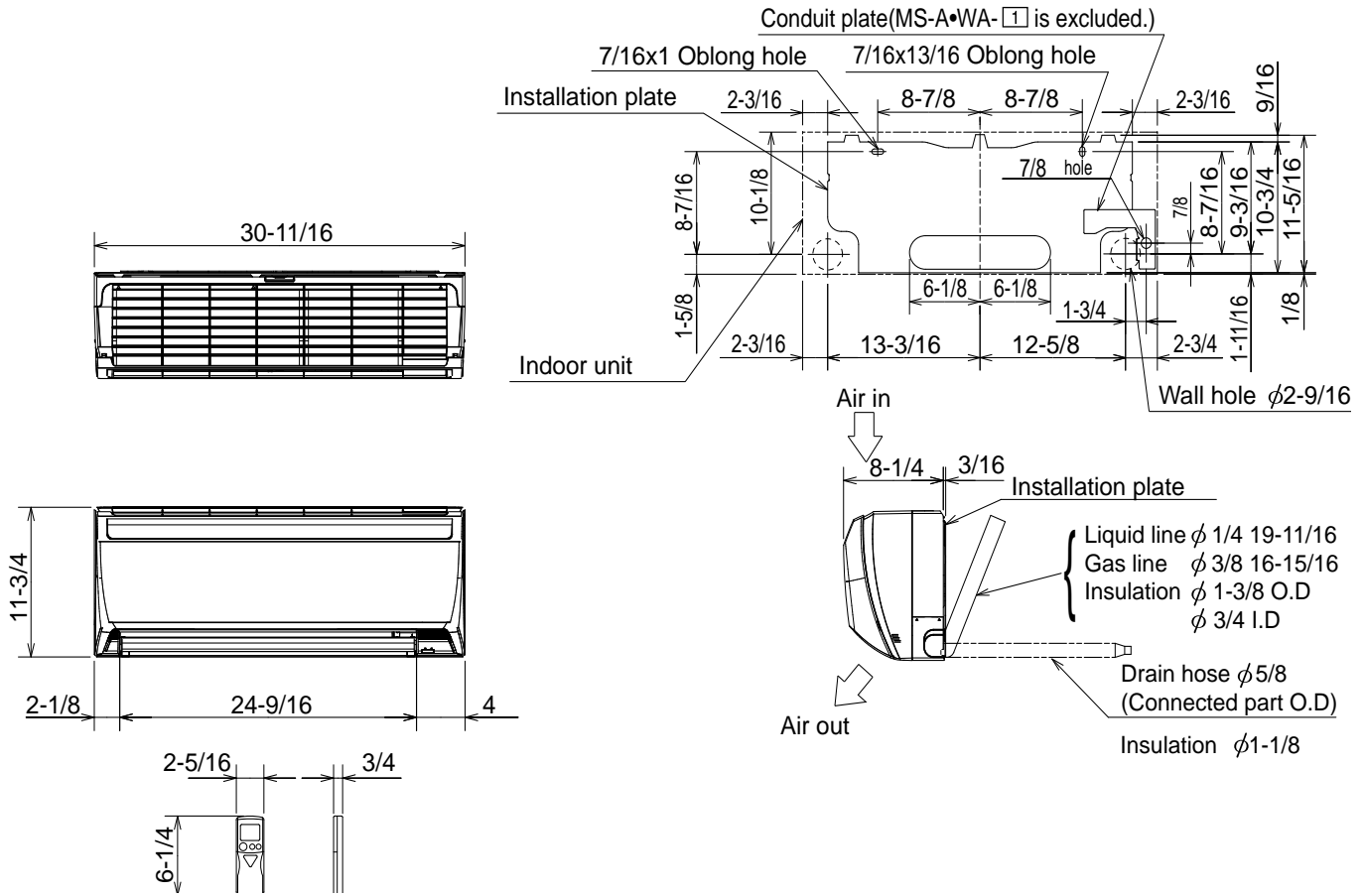

5

WIRING DIAGRAM

MS-A09WA
MS-A12WA

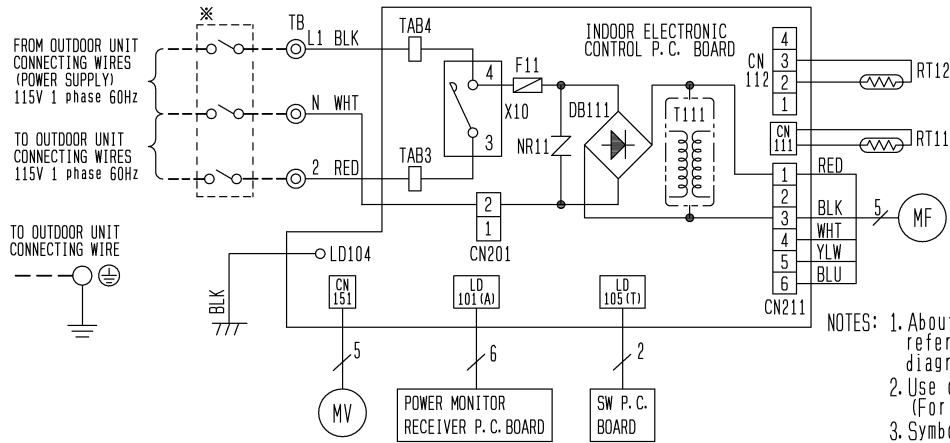

SYMBOL	NAME	SYMBOL	NAME
DB111	DIODE STACK	RT11	ROOM TEMP. THERMISTOR
F11	FUSE (T3.15A/250V)	RT12	COIL TEMP. THERMISTOR
MF	FAN MOTOR	T111	SWITCHING TRANSFORMER
MV	VANE MOTOR (HORIZONTAL)	TB	TERMINAL BLOCK
NR11	VARISTOR	X10	CONTACTOR

※ A disconnect may be required by local code.

6

REFRIGERANT SYSTEM DIAGRAM

MS-A09WA
MS-A12WA

Unit : inch

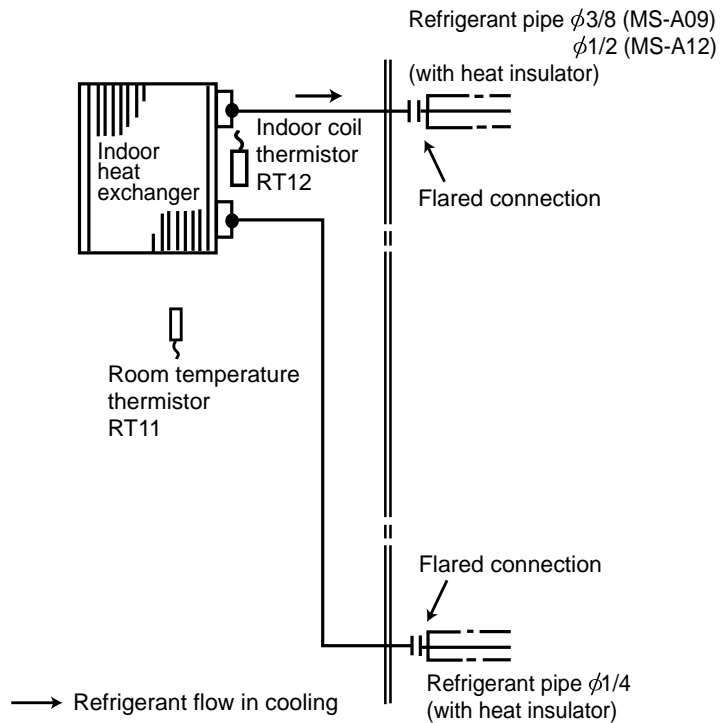

MS-A09WA MS-A12WA

7-1. TIMER SHORT MODE

For service, set time can be shortened by short circuit of JPG and JPS the electronic control P.C. board.
The time will be shortened as follows. (Refer to 8-7.)

Set time : 1-minute → 1-second

Set time : 3-minute → 3-second (It takes 3 minutes for the compressor to start operation. However, the starting time is shortened by short circuit-of JPG and JPS.)

7-2. P.C. BOARD MODIFICATION FOR INDIVIDUAL OPERATION

A maximum of 4 indoor units with wireless remote controllers can be used in a room.

In this case, to operate each indoor unit individually by each remote controller, P.C. boards of remote controller must be modified according to the number of the indoor unit.

How to modify the remote controller P.C. board

Remove batteries before modification.

The board has a print as shown below :

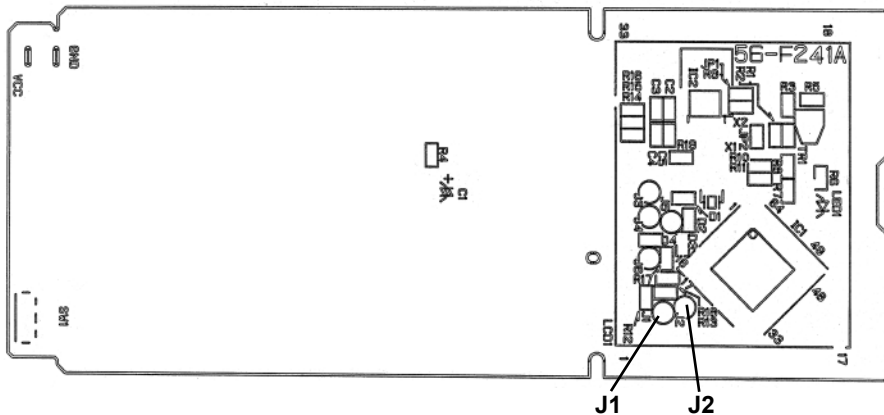

NOTE : For modification, take out the batteries and press the OPERATE/STOP(ON/OFF)button twice or 3 times at first.
After finish modification, put back the batteries then press the RESET button.

The P.C. board has the print "J1" and "J2". Solder "J1" and "J2" according to the number of indoor unit as shown in Table 1.
After modification, press the RESET button.

Table 1

	1 unit operation	2 units operation	3 units operation	4 units operation
No. 1 unit	No modification	Same as at left	Same as at left	Same as at left
No. 2 unit	—	Solder J1	Same as at left	Same as at left
No. 3 unit	—	—	Solder J2	Same as at left
No. 4 unit	—	—	—	Solder both J1 and J2

How to set the remote controller exclusively for particular indoor unit

After you turn the breaker ON, the first remote controller that sends the signal to the indoor unit will be regarded as the remote controller for the indoor unit.

The indoor unit will only accept the signal from the remote controller that has been assigned to the indoor unit once they are set.

The setting will be cancelled if the breaker has turned off, or the power supply has shut down.

Please conduct the above setting once again after the power has restored.

7-3. AUTO RESTART FUNCTION

When the indoor unit is controlled with the remote controller, the operation mode, the set temperature, and the fan speed are memorized by the indoor electronic control P.C. board. The "AUTO RESTART FUNCTION" sets to work the moment power has restored after power failure. Then, the unit will restart automatically.

Operation

- ① If the main power has been cut, the operation settings remain.
- ② After the power is restored, the unit restarts automatically according to the memory.
(However, it takes at least 3 minutes for the compressor to start running.)

How to release "AUTO RESTART FUNCTION"

- ① Turn off the main power for the unit.
- ② Solder the Jumper wire JR07 on the indoor electronic control P.C. board. (Refer to 8-7.)

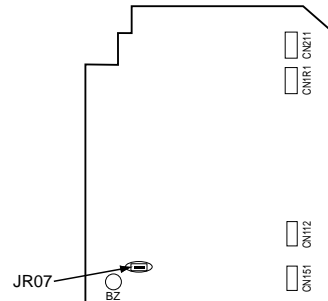

NOTE:

- The operation settings are memorized when 10 seconds have passed after the indoor unit was operated with the remote controller.
- If main power is turned OFF or a power failure occurs while AUTO START/STOP timer is active, the timer setting is cancelled.
- If the unit has been off with the remote controller before power failure, the auto restart function does not work as the power button of the remote controller is off.
- To prevent breaker off due to the rush of starting current, systematize other home appliance not to turn on at the same time.
- When some air conditioners are connected to the same supply system, if they are operated before power failure, the starting current of all the compressors may flow simultaneously at restart. Therefore, the special counter-measures are required to prevent the main voltage-drop or the rush of the starting current by adding to the system that allows the units to start one by one.

8

TROUBLESHOOTING

MS-A09WA MS-A12WA

8-1. CAUTIONS ON TROUBLESHOOTING

1. Before troubleshooting, check the following

- 1) Check the power supply voltage.
- 2) Check the indoor/outdoor connecting wire for miswiring.

2. Take care of the following during servicing

- 1) Before servicing the air conditioner, be sure to turn off the unit first with the remote controller, and then after confirming the horizontal vane is closed, turn off the breaker and/or disconnect the power plug.
- 2) Be sure to turn OFF the power supply before removing the front panel, the cabinet, the top panel, and the electronic control P.C. board.
- 3) When removing the electronic control P.C. board, hold the edge of the board with care NOT to apply stress on the components.
- 4) When connecting or disconnecting the connectors, hold the housing of the connector. DO NOT pull the lead wires.

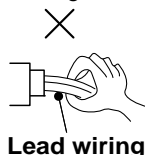

Lead wiring



Housing point

3. Troubleshooting procedure

- 1) First, check if the OPERATION INDICATOR lamp on the indoor unit is blinking on and off to indicate an abnormality. To make sure, check how many times the abnormality indication is blinking on and off before starting service work.
- 2) Before servicing check that the connector and terminal are connected properly.
- 3) When the electronic control P.C. board seems to be defective, check the copper foil pattern for disconnection and the components for bursting and discoloration.
- 4) When troubleshooting, refer to 8-2., 8-3. and 8-4.

4. How to replace batteries

Weak batteries may cause the remote controller malfunction.

In this case, replace the batteries to operate the remote controller normally.

- ① Remove the front lid and insert batteries. Then reattach the front lid.

- ② Press RESET button with tip end of ball point pen or the like, and then use the remote controller.

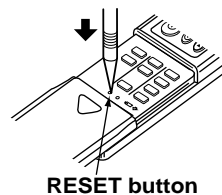
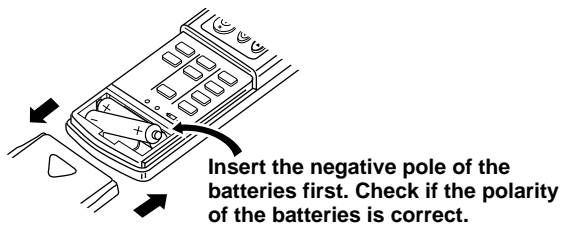

- NOTE :**
1. If RESET button is not pressed, the remote controller may not operate correctly.
 2. This remote controller has a circuit to automatically reset the microcomputer when batteries are replaced. This function is equipped to prevent the microcomputer from malfunctioning due to the voltage drop caused by the battery replacement.

8-2. FAILURE MODE RECALL FUNCTION

Outline of the function

This air conditioner can memorize the abnormal condition which has occurred once.

Even though LED indication listed on the troubleshooting check table (8-4.) disappears, the memorized failure details can be recalled.

1. Flow chart of failure mode recall function for the indoor/outdoor unit

Operational procedure

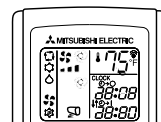
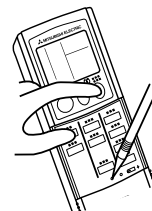
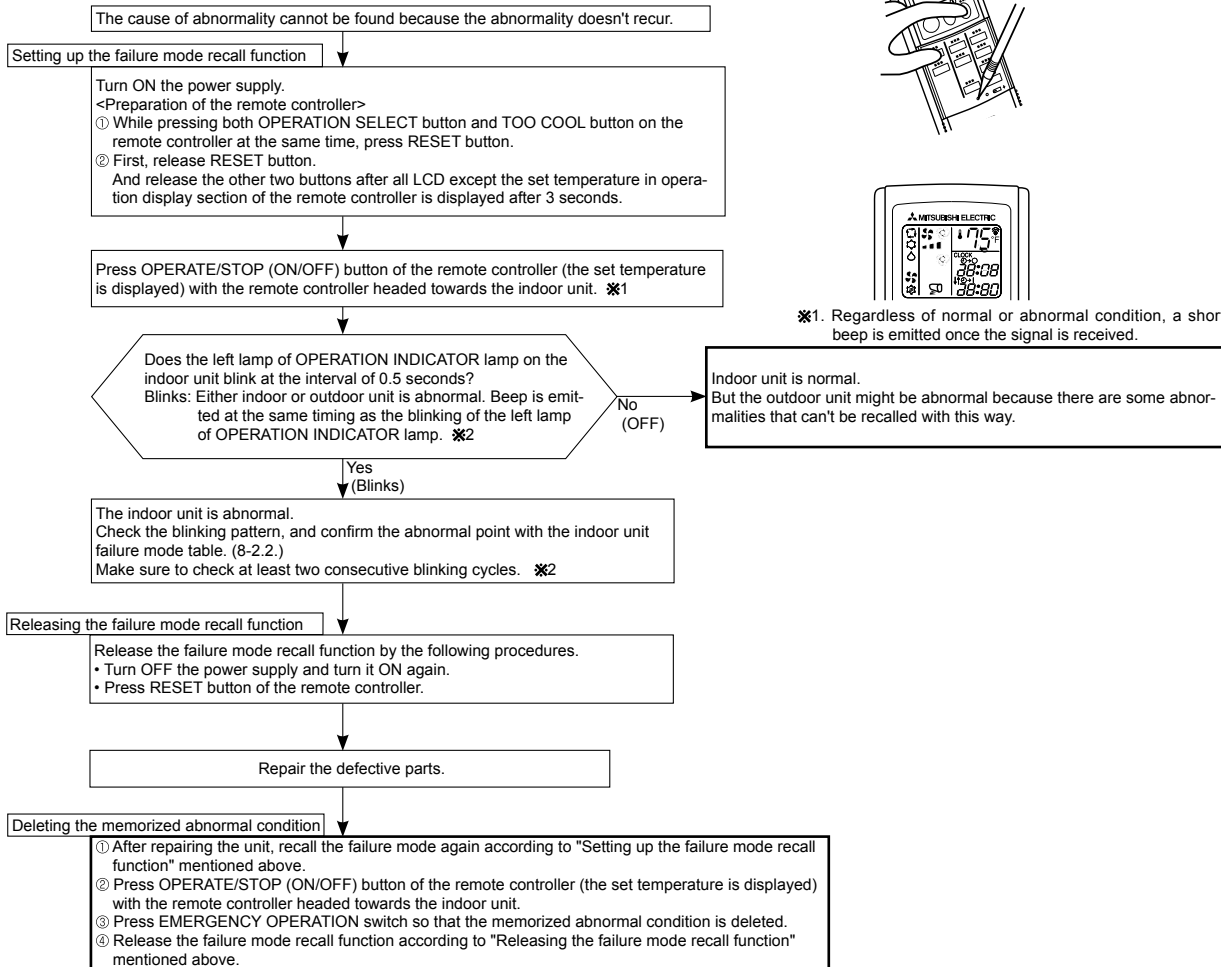

※1. Regardless of normal or abnormal condition, a short beep is emitted once the signal is received.

NOTE: 1. Make sure to release the failure mode recall function once it's set up, otherwise the unit cannot operate properly.
 2. If the abnormal condition is not deleted from the memory, the last abnormal condition is kept memorized.

※2. Blinking pattern when the indoor unit is abnormal:

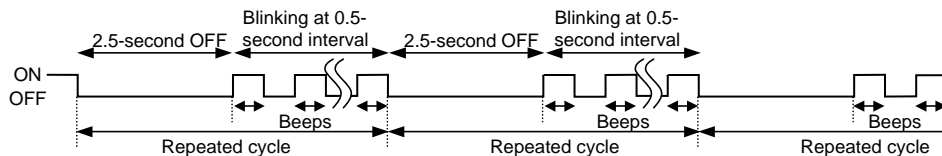



2. Indoor unit failure mode table

Left lamp of OPERATION INDICATOR lamp	Abnormal point (Failure mode)	Condition	Correspondence
Not lighted	Normal	—	—
1-time blink every 0.5-second	Room temperature thermistor	The room temperature thermistor short or open circuit is detected every 8 seconds during operation.	Refer to the characteristics of the room temperature thermistor (8-7.).
2-time blink 2.5-second OFF	Indoor coil thermistor	The indoor coil thermistor short or open circuit is detected every 8 seconds during operation.	Refer to the characteristics of the main indoor coil thermistor, the sub indoor coil thermistor (8-7.).
11-time blink 2.5-second OFF	Indoor fan motor	The rotational frequency feedback signal is not emit during the 12 seconds the indoor fan operation.	Refer to 8-6.Ⓐ "Check of indoor fan motor".
12-time blink 2.5-second OFF	Indoor control system	It cannot properly read data in the nonvolatile memory of the indoor electronic control P.C. board.	Replace the indoor electronic control P.C. board.

NOTE : Blinking patterns of this mode differ from the ones of TROUBLESHOOTING CHECK TABLE (8-4.).

8-3. INSTRUCTION OF TROUBLESHOOTING

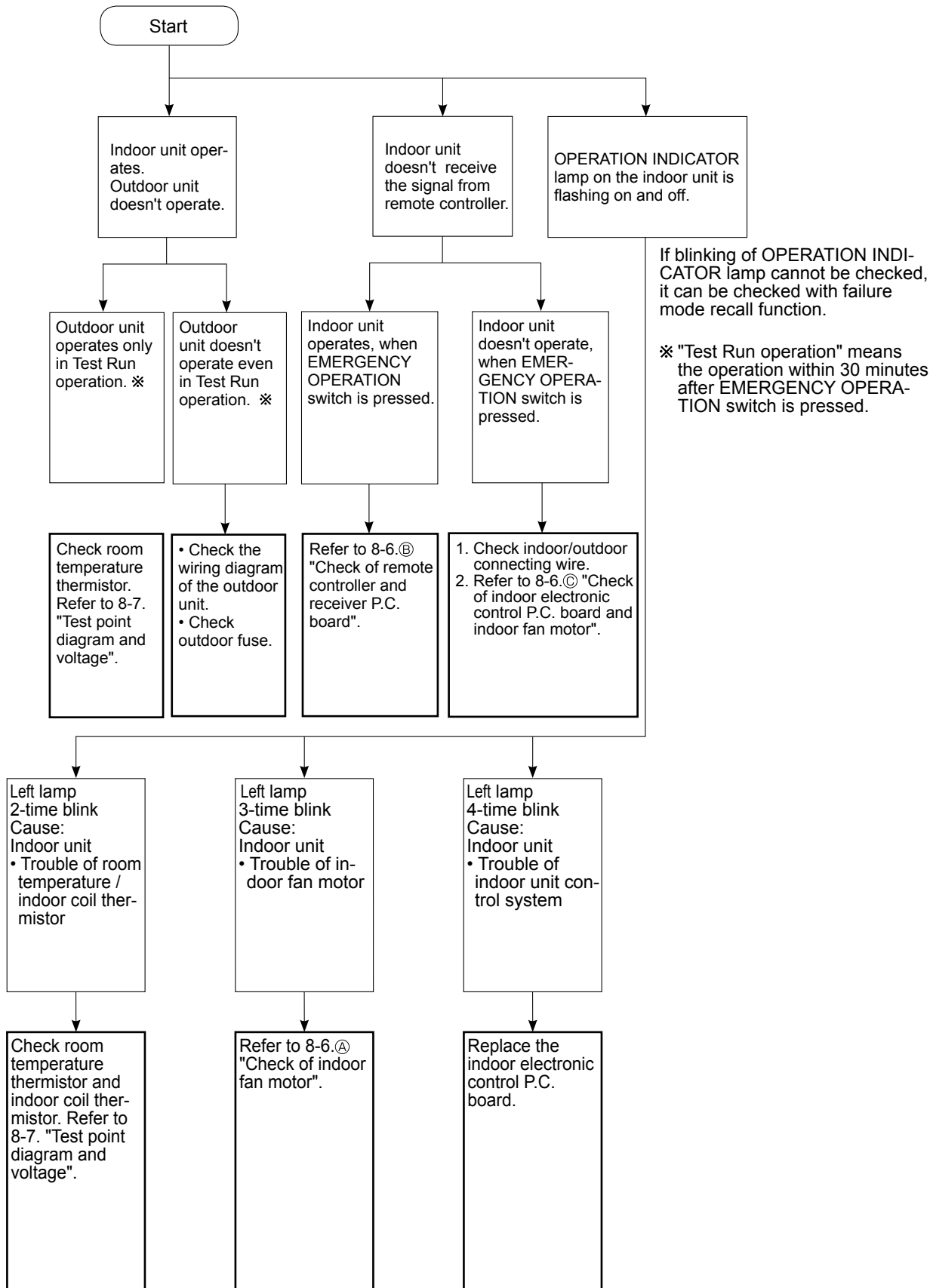

8-4. TROUBLESHOOTING CHECK TABLE

Before taking measures, make sure that the symptom reappears for accurate troubleshooting.
When the indoor unit has started operation and detected an abnormality of the following condition (the first detection after the power ON), the indoor fan motor turns OFF and OPERATION INDICATOR lamp blinks.

OPERATION INDICATOR



- ☀ Lighted
- ☀◐ Blinking
- Not lighted

No.	Abnormal point	Operation indicator lamp	Symptom	Condition	Correspondence
1	Indoor coil thermistor	Left lamp blinks. 2-time blink ☀◐☀◐○○○○○○☀◐☀◐○○ 2.5-second OFF	Indoor unit and outdoor unit do not operate.	The indoor coil or the room temperature thermistor is short or open circuit.	• Refer to the characteristics of indoor coil thermistor, and the room temperature thermistor (8-7).
	Room temperature thermistor				
2	Indoor fan motor	Left lamp blinks. 3-time blink ☀◐☀◐☀◐○○○○○○☀◐☀◐☀◐○○○○ 2.5-second OFF			
3	Indoor control system	Left lamp blinks. 4-time blink ☀◐☀◐☀◐☀◐○○○○○○☀◐☀◐☀◐○○○○ 2.5-second OFF	It cannot properly read data in the nonvolatile memory of the indoor electronic control P.C. board.	• Replace the indoor electronic control P.C. board.	

8-5. TROUBLE CRITERION OF MAIN PARTS
MS-A09WA MS-A12WA

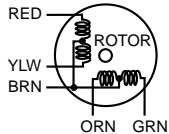
Part name	Check method and criterion	Figure				
Room temperature thermistor (RT11)	Measure the resistance with a tester. (Part temperature 50 ~ 86°F)					
Indoor coil thermistor (RT12)	Refer to 8-7. "Test point diagram and voltage", the chart of thermistor.					
Indoor fan motor (MF)	Check 8-6. ㉞.					
Horizontal vane motor (MV)	Measure the resistance between the terminals with a tester. (Part temperature 50 ~ 86°F) <table border="1" data-bbox="459 715 1142 795" style="margin-left: 20px;"> <thead> <tr> <th data-bbox="459 715 802 751">Color of the lead wire</th> <th data-bbox="802 715 1142 751">Normal</th> </tr> </thead> <tbody> <tr> <td data-bbox="459 751 802 795">BRN - other one</td> <td data-bbox="802 751 1142 795">235 ~ 255 Ω</td> </tr> </tbody> </table>	Color of the lead wire	Normal	BRN - other one	235 ~ 255 Ω	
Color of the lead wire	Normal					
BRN - other one	235 ~ 255 Ω					

8-6. TROUBLESHOOTING FLOW

A Check of indoor fan motor

The indoor fan motor error has occurred, and the indoor fan doesn't operate.

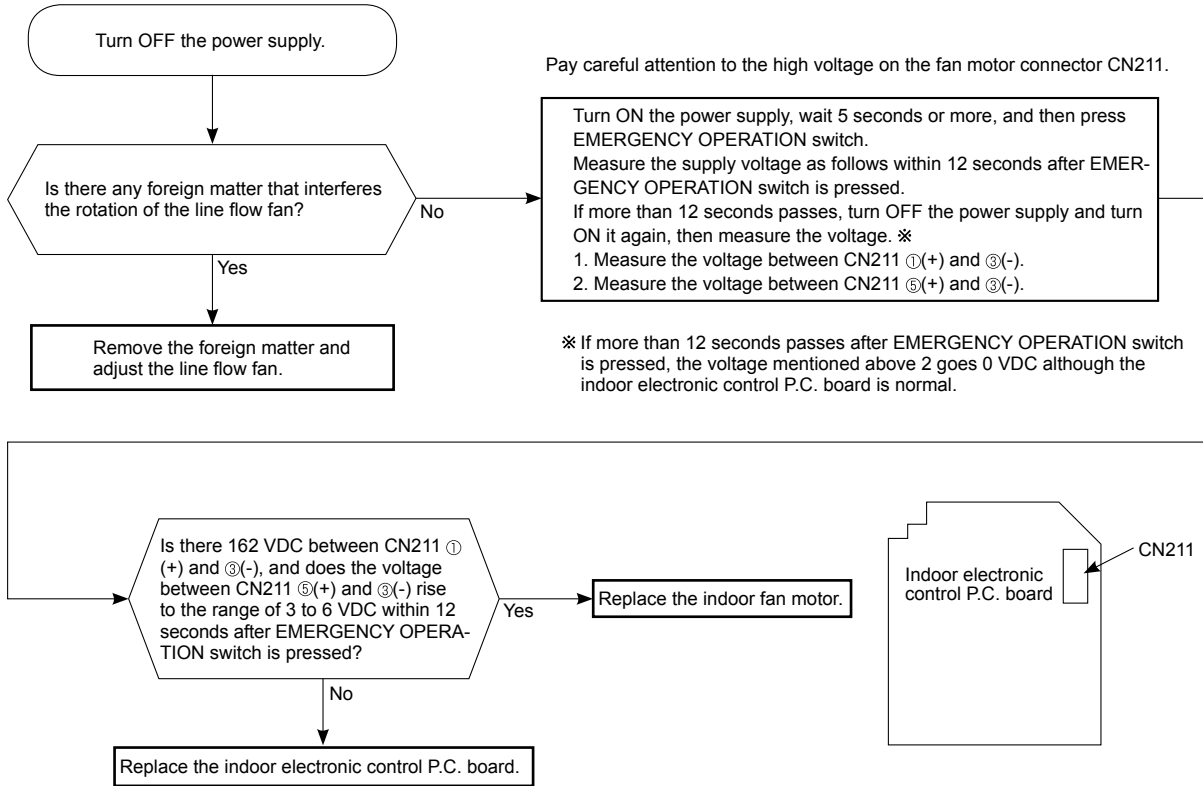

The indoor fan motor error has occurred, and the indoor fan repeats "12-second ON and 30-second OFF" 3 times, and then stops.

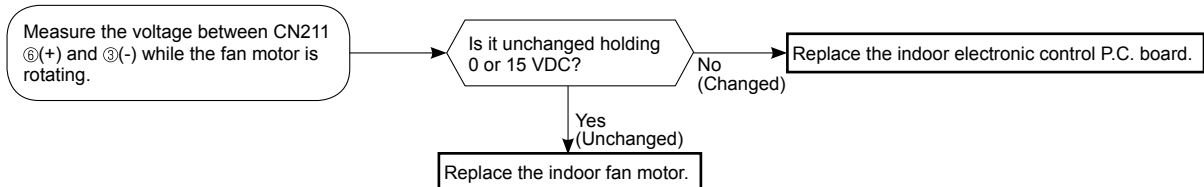

B Check of remote controller and indoor electronic control P.C. board

※Check if the remote controller is exclusive for this air conditioner.

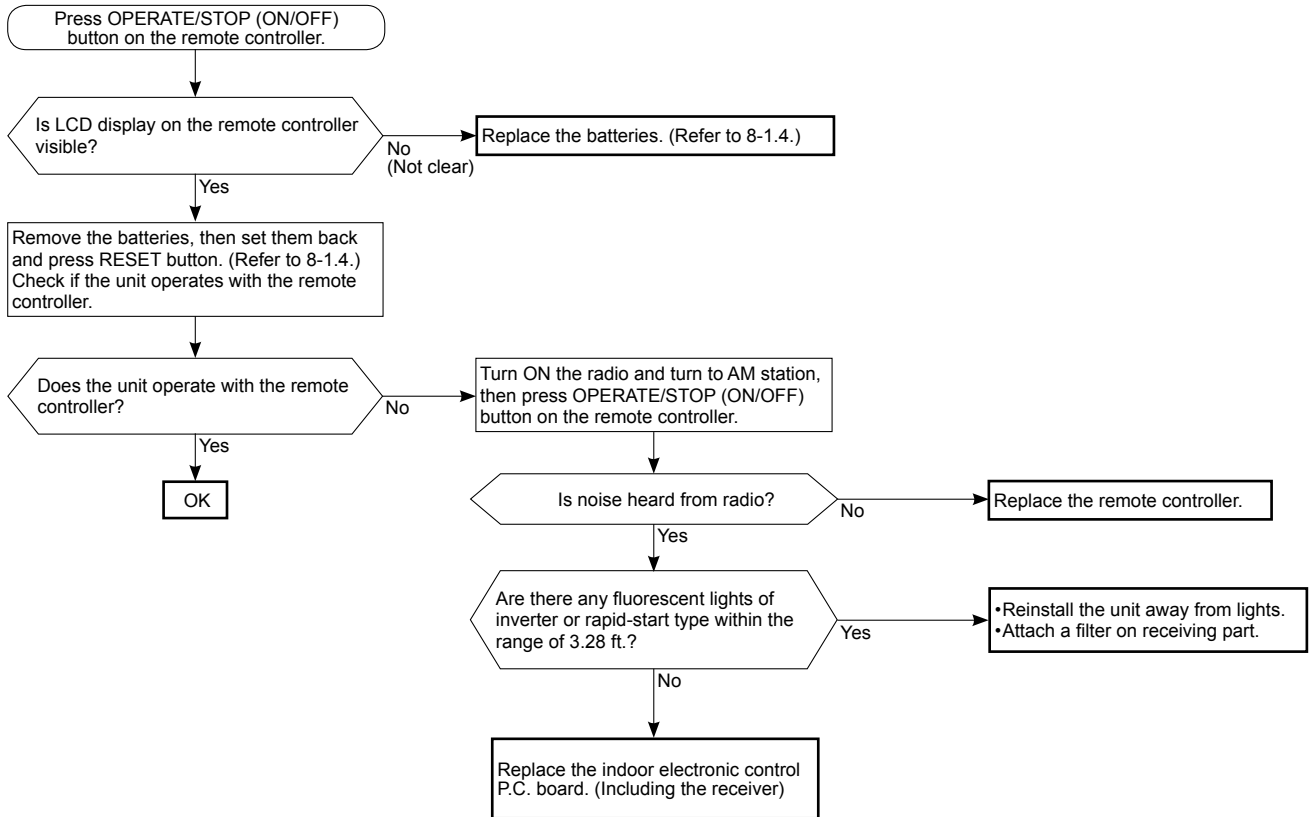

C Check of indoor electronic control P.C. board and indoor fan motor

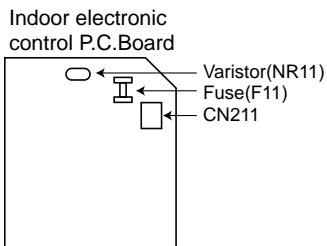
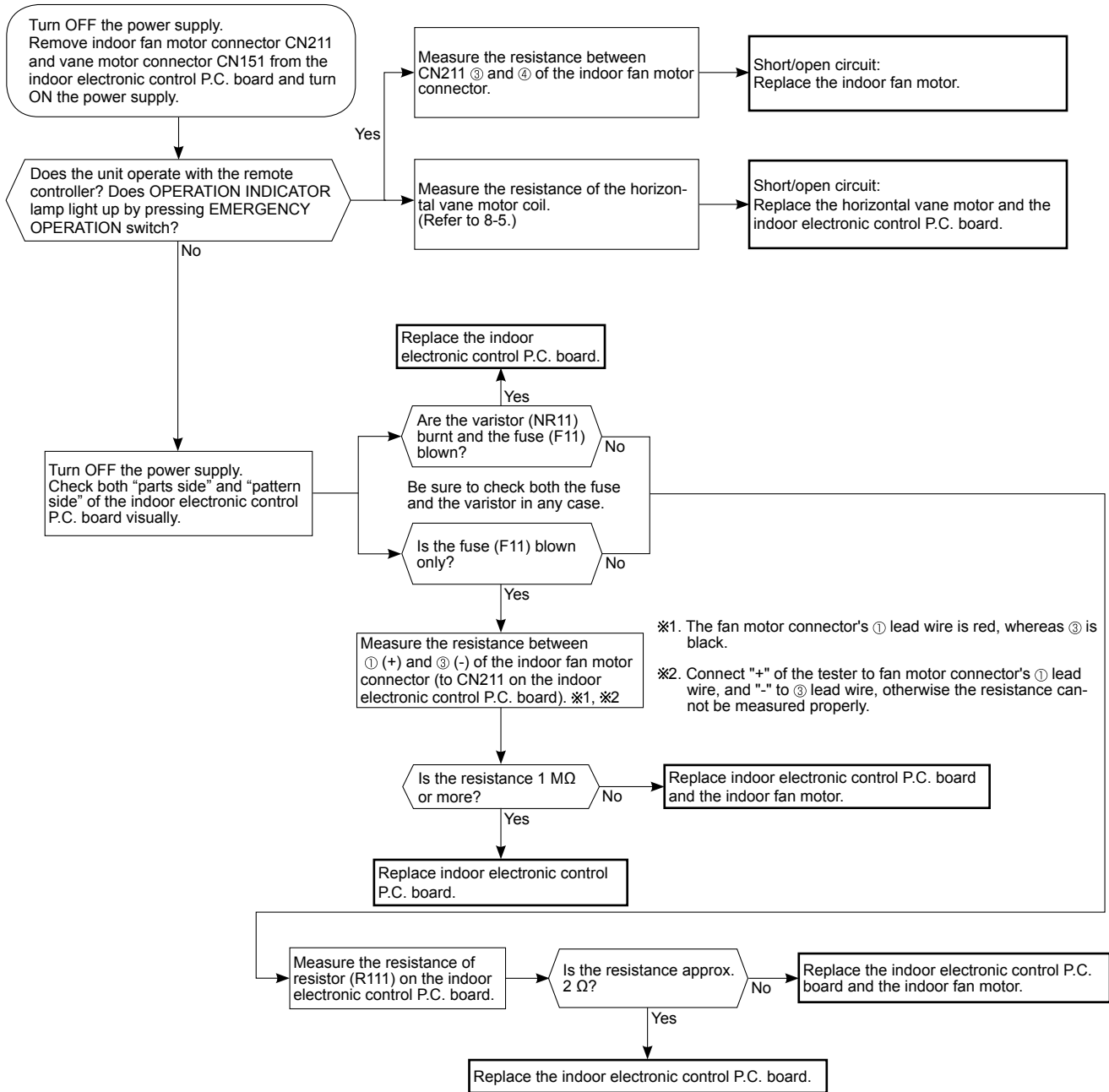

D Electromagnetic noise enters into TV sets or radios

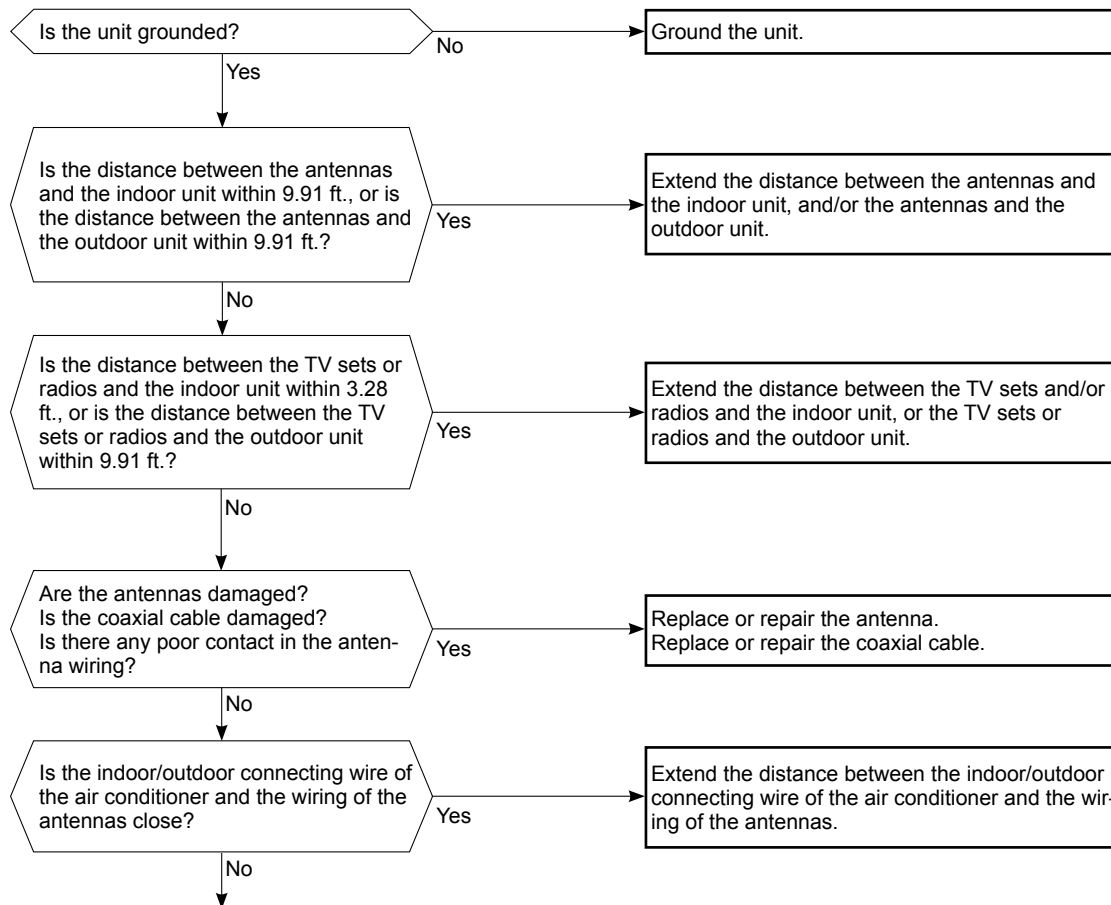

Even if all of the above conditions are fulfilled, the electromagnetic noise may enter, depending on the electric field strength or the installation condition (combination of specific conditions such as antennas or wiring).

Check the followings before asking for service.

1. Devices affected by the electromagnetic noise
TV sets, radios (FM/AM broadcast, shortwave)
2. Channel, frequency, broadcast station affected by the electromagnetic noise
3. Channel, frequency, broadcast station unaffected by the electromagnetic noise
4. Layout of ;
indoor/outdoor unit of the air conditioner, indoor/outdoor wiring, grounding wire, antennas, wiring from antennas, receiver
5. Electric field intensity of the broadcast station affected by the electromagnetic noise
6. Presence or absence of amplifier such as booster
7. Operation condition of air conditioner when the electromagnetic noise enters in
 - 1) Turn OFF the power supply once, and then turn ON the power supply. In this situation, check for the electromagnetic noise.
 - 2) Within 3 minutes after turning ON the power supply, press OPERATE/STOP (ON/OFF) button on the remote controller for power ON, and check for the electromagnetic noise.
 - 3) After a short time (3 minutes later after turning ON), the outdoor unit starts running. During operation, check for the electromagnetic noise.
 - 4) Press OPERATE/STOP (ON/OFF) button on the remote controller for power OFF, when the outdoor unit stops but the indoor/outdoor communication still runs on. In this situation, check for the electromagnetic noise.

8-7. TEST POINT DIAGRAM AND VOLTAGE

MS-A09WA MS-A12WA Indoor electronic control P.C. board

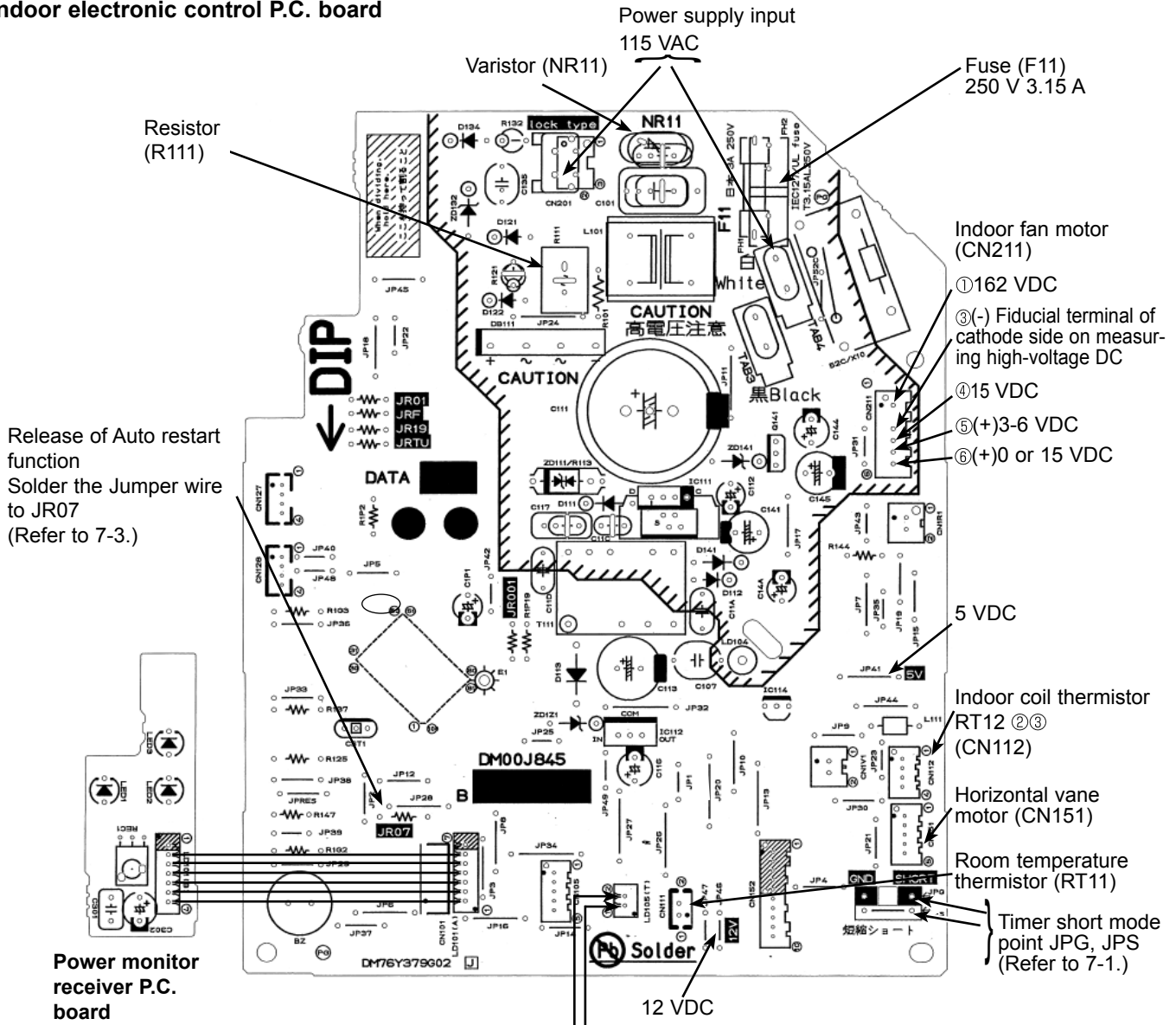

Release of Auto restart function
Solder the Jumper wire to JR07
(Refer to 7-3.)

- Indoor fan motor (CN211)
- ① 162 VDC
- ③ (-) Fiducial terminal of cathode side on measuring high-voltage DC
- ④ 15 VDC
- ⑤ (+) 3-6 VDC
- ⑥ (+) 0 or 15 VDC

- 5 VDC
- Indoor coil thermistor RT12 ②③ (CN112)
- Horizontal vane motor (CN151)
- Room temperature thermistor (RT11)
- Timer short mode point JPG, JPS (Refer to 7-1.)

Indoor coil thermistor [RT12]
Room temperature thermistor (RT11)

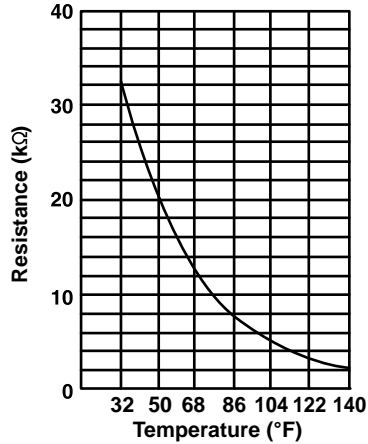

<"Terminal with locking mechanism" Detaching points>

The terminal which has the locking mechanism can be detached as shown below. There are two types (refer to (1) and (2)) of the terminal with locking mechanism. The terminal without locking mechanism can be detached by pulling it out. Check the shape of the terminal before detaching.

(1) Slide the sleeve and check if there is a locking lever or not.

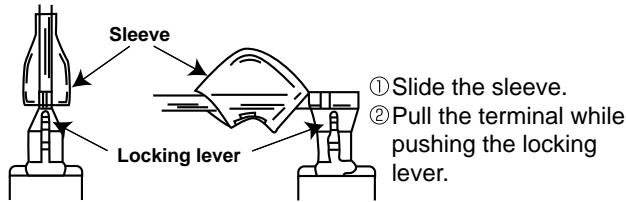

(2) The terminal with this connector has the locking mechanism.

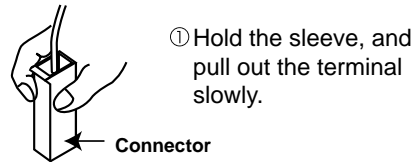

MS-A09WA MS-A12WA

OPERATING PROCEDURE	PHOTOS
<p>1. Removing the panel</p> <p>(1) Remove the horizontal vane.</p> <p>(2) Remove the screw caps of the panel. Remove the screws. (Photo 1)</p> <p>(3) Hold the lower part of both ends on the panel and pull it slightly toward you, and then remove the panel by pushing it upward.</p> <p>Photo 3</p> <p>Screw of the conduit cover Terminal block cover Conduit cover</p> <p>MS-A09/12WA - 1</p>	<p>Photo 1</p> <p>Horizontal vane Screws of the panel</p> <p>Photo 2</p> <p>Terminal block cover Conduit cover Screw of the conduit cover Conduit plate</p> <p>MS-A09/12WA</p>

OPERATING PROCEDURE

2. Removing the electronic control P.C. board, the power monitor receiver P.C. board, SW P.C. board and the terminal block

- (1) Remove the horizontal vane, the panel (refer to 1.) and the corner box.
- (2) Remove the screw of the conduit cover, and conduit cover. (Photo 2 or Photo 3)
- (3) Remove the indoor/outdoor connecting wire.
- (4) Remove the switch holder from the electrical cover. (Photo 4)
- (5) Remove the screw of the electrical cover, and then the electrical cover. (Photo 4)
- (6) Remove the ground wire connected to the indoor electronic control P.C. board from the electrical box. (Photo 5)
- (7) Unhook the power monitor receiver P.C. board holder from the catch. (Photo 4)
- (8) Open the rear cover of the power monitor receiver P.C. board holder and pull out the power monitor receiver P.C. board.
- (9) Open the switch holder and pull out SW P.C. board.
- (10) Pull the electronic control P.C. board slightly toward you from the electrical box, and disconnect TAB3, TAB4 and all the connectors on the electronic control P.C. board. (LD101 and LD105 are direct-mounted to the electronic control P.C. board.)
- (11) Pull out the electronic control P.C. board from the electrical box.
- (12) Remove the ground wire connected to the heat exchanger from the electrical box. (Photo 5)
- (13) Unhook the catches of the electrical box, and pull out the electrical box.
- (14) Remove the screw of the terminal block cover, and then remove the terminal block cover and the terminal block holder. (Photo 6)
- (15) Remove the terminal block by sliding it.

3. Removing the electrical box

- (1) Remove the horizontal vane, the panel (refer to 1.) and the corner box.
- (2) Remove the screw of Conduit cover, and then the indoor/outdoor connecting wire. (Photo 2 or Photo 3)
- (3) Remove the switch holder and the electrical cover. (Photo 4)
- (4) Remove the ground wire connected to the heat exchanger from the electrical box. (Photo 5)
- (5) Disconnect the following connectors on the electronic control P.C. board; the fan motor connector <CN211>, the indoor coil thermistor connector <CN112>, the vane motor connector <CN151>. (Photo 5)
- (6) Unhook the catches of the electrical box, and pull out the electrical box.

PHOTOS

Photo 4

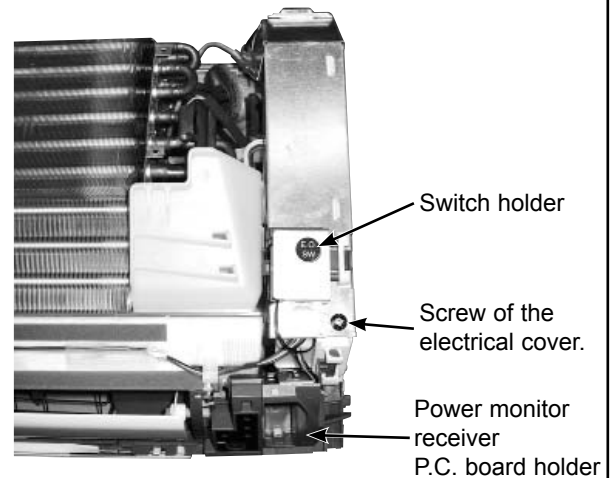

Photo 5

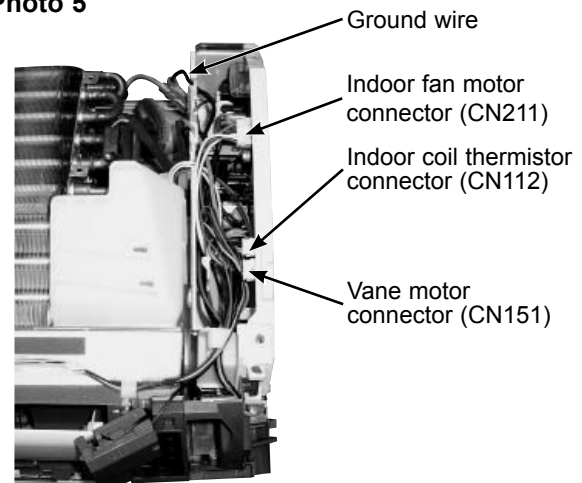
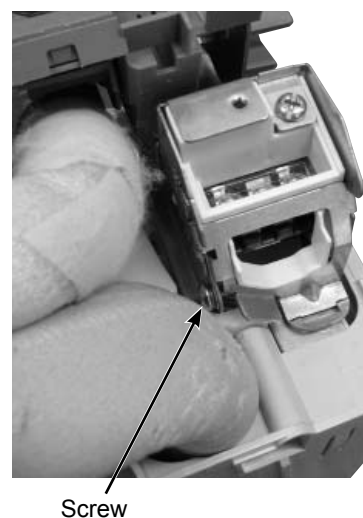

Photo 6





OPERATING PROCEDURE

PHOTOS

- 4. Removing the horizontal vane motor unit**
- (1) Remove the horizontal vane and the panel. (Refer to 1.)
 - (2) Remove the screws of the horizontal vane motor unit, and pull out the horizontal vane motor unit. (Photo 7)
 - (3) Disconnect the connector from the horizontal vane motor unit.

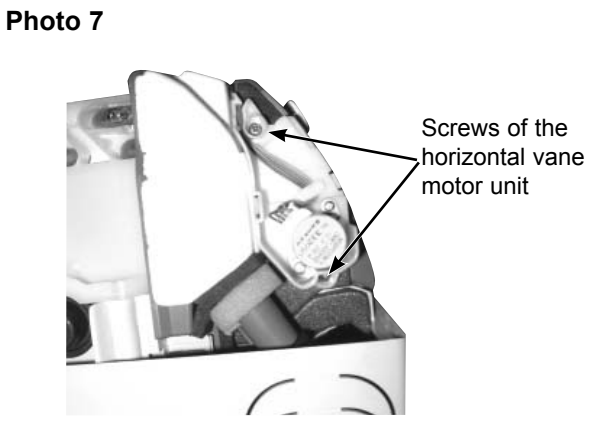

- 5. Removing the indoor fan motor and the line flow fan**
- (1) Remove the horizontal vane, the panel (Refer to 1.) and the corner box.
 - (2) Remove the switch holder and the electrical box. (Refer to 3.)
 - (3) Pull out the drain hose from the nozzle assembly, and remove the nozzle assembly.
 - (4) Remove the screws fixing the motor bed. (Photo 8)
 - (5) Loosen the screw fixing the line flow fan. (Photo 9)
 - (6) Remove the motor bed together with fan motor and motor band.
 - (7) Release the hooks of the motor band, and remove the motor band then pull out the indoor fan motor.
 - (8) Remove the screws fixing the left side of the heat exchanger. (Photo 10)
 - (9) Lift the heat exchanger, and pull out the line flow fan to the lower-left.

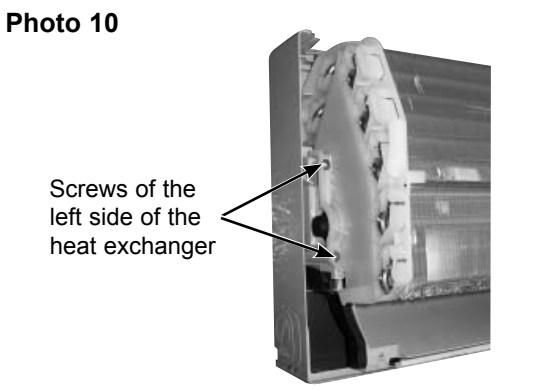
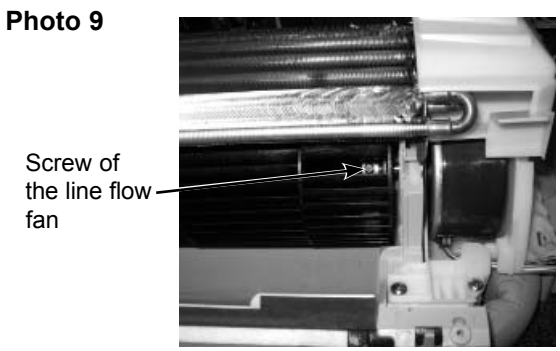
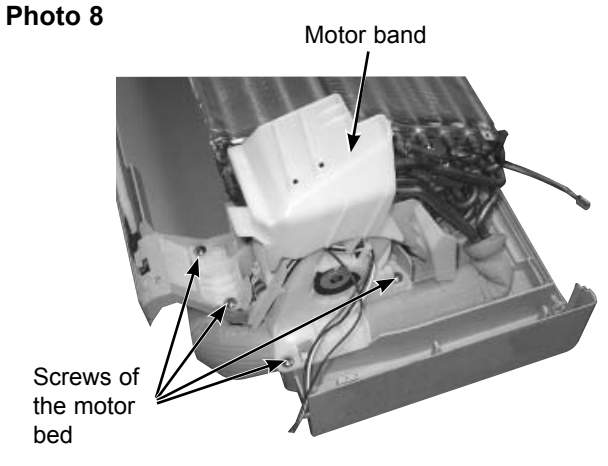

10-1. PARTS LIST (non-RoHS compliant)

MS-A09WA

MS-A12WA

1. INDOOR UNIT STRUCTURAL PARTS

2. ACCESSORY AND REMOTE CONTROLLER

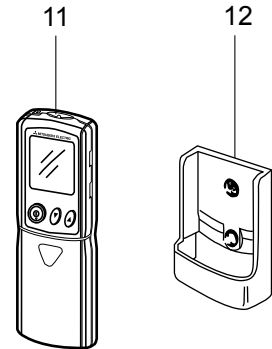
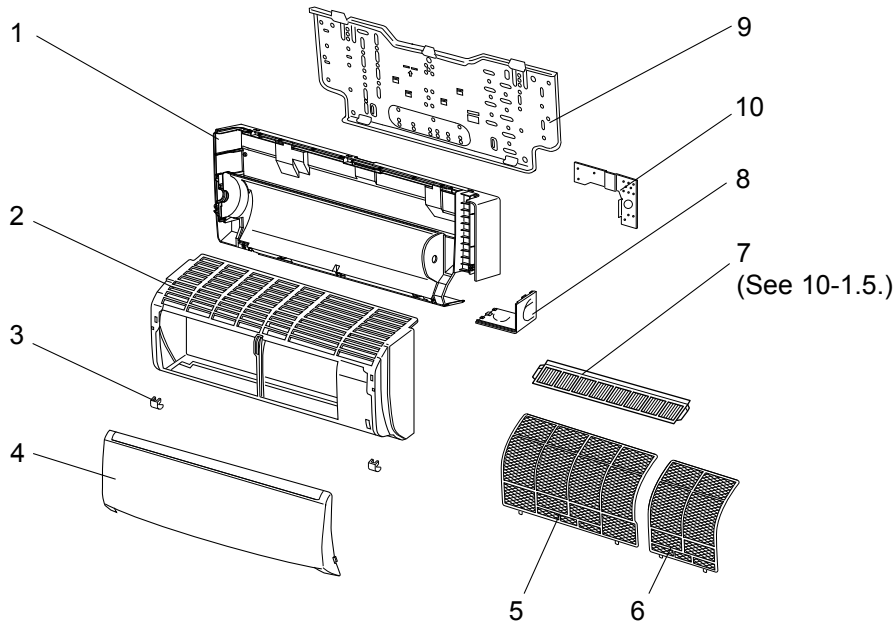

1. INDOOR UNIT STRUCTURAL PARTS

No.	Part No.	Part name	Symbol in Wiring Diagram	Q'ty/unit		Remarks
				MS-A09WA	MS-A12WA	
1	E02 A32 234	BOX		1	1	
2	E02 A49 000	PANEL ASSEMBLY		1	1	Including No.3,4
3	E02 913 067	SCREW CAP		2	2	2 PC/SET
4	E02 915 010	FRONT PANEL		1	1	
5	E02 915 100	CATECHIN AIR FILTER (LEFT)		1	1	
6	E02 916 100	CATECHIN AIR FILTER (RIGHT)		1	1	
7	—	AIR CLEANING FILTER		1	1	MAC-415FT-E
8	E02 A32 975	CORNER BOX (RIGHT)		1	1	
9	E02 913 970	INSTALLATION PLATE		1	1	
10	E02 A49 978	CONDUIT PLATE		1	1	

2. ACCESSORY AND REMOTE CONTROLLER

11	E02 A49 426	REMOTE CONTROLLER		1	1	KM06C
12	E02 527 083	REMOTE CONTROLLER HOLDER		1	1	

MS-A09WA

MS-A12WA

3. INDOOR UNIT ELECTRICAL PARTS AND FUNCTIONAL PARTS

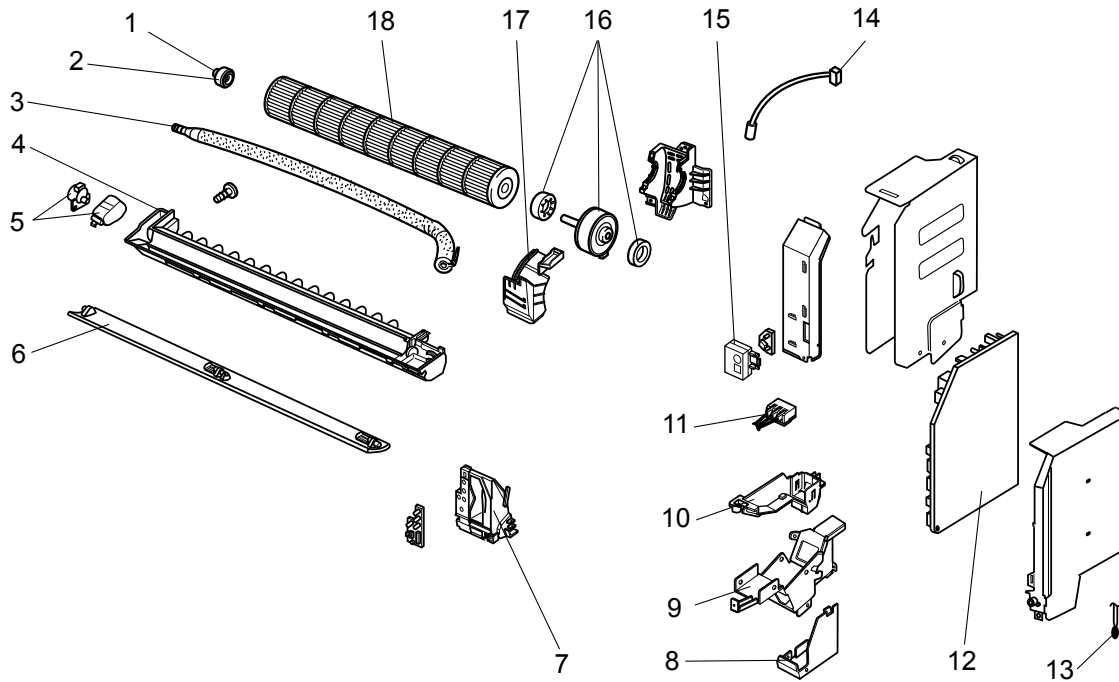

No.	Part No.	Part name	Symbol in Wiring Diagram	Q'ty/unit		Remarks
				MS-A09WA	MS-A12WA	
1	E02 751 509	BEARING MOUNT		1	1	
2	E02 001 504	SLEEVE BEARING		1	1	
3	E02 897 702	DRAIN HOSE		1	1	
4	E02 A49 235	NOZZLE ASSEMBLY		1	1	
5	E02 897 303	VANE MOTOR UNIT (HORIZONTAL)	MV	1	1	UP & DOWN
6	E02 913 040	HORIZONTAL VANE		1	1	
7	E02 913 095	POWER MONITOR RECEIVER P.C. BOARD HOLDER		1	1	
8	E02 A49 979	CONDUIT COVER		1	1	
9	E02 A49 780	TERMINAL BLOCK COVER		1	1	
10	E02 A49 779	TERMINAL BLOCK HOLDER		1	1	
11	E02 A49 375	TERMINAL BLOCK	TB	1	1	
12	E02 A49 452	ELECTRONIC CONTROL P.C. BOARD		1		
	E02 A50 452	※1			1	
13	E02 897 308	ROOM TEMPERATURE THERMISTOR	RT11	1	1	
14	E02 897 307	INDOOR COIL THERMISTOR	RT12	1	1	
15	E02 915 782	SWITCH HOLDER		1	1	
16	E02 A49 300	INDOOR FAN MOTOR ※2	MF	1	1	RC0H30-□□
17	E02 897 333	MOTOR BAND		1	1	
18	E02 897 302	LINE FLOW FAN		1	1	

※1 Including SW P.C. BOARD and POWER MONITOR RECEIVER P.C. BOARD

※2 Including FAN MOTOR RUBBER MOUNT (2 PC/SET)

MS-A09WA

MS-A12WA

4. INDOOR UNIT HEAT EXCHANGER

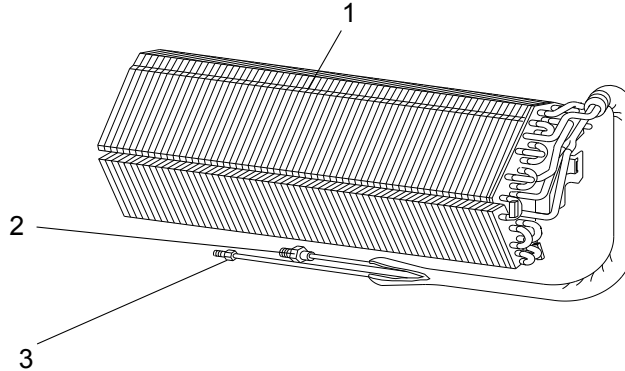

No.	Part No.	Part name	Symbol in Wiring Diagram	Q'ty/unit		Remarks
				MS-A09WA	MS-A12WA	
1	E02 A49 620	INDOOR HEAT EXCHANGER		1		
	E02 A50 620				1	
2	E02 151 666	UNION (GAS)		1		ø3/8
	E02 155 666				1	ø1/2
3	E02 151 667	UNION (LIQUID)		1	1	ø1/4

5. AIR CLEANING FILTER (ANTI-ALLERGY ENZYME FILTER)

- AIR CLEANING FILTER removes fine dust of 0.01 micron from air by means of static electricity.
- Normal life of AIR CLEANING FILTER is 1 year.
If AIR CLEANING FILTER is to be washed, soak AIR CLEANING FILTER in water (when showing dirt, in lukewarm water) and rinse it delicately, without removing the filter from the frame about once every 3 months.
- Clogged AIR CLEANING FILTER may reduce the air conditioner capacity or cause frost on the air outlet.
- Do not remove or attach AIR CLEANING FILTER during unit operation.

Model	Part No.
MS-A09WA MS-A12WA	MAC-415FT-E

Replacement of the air cleaning filter

- (1) Remove the catechin air filter (left one).
The air cleaning filter is not attached to the right side catechin air filter.

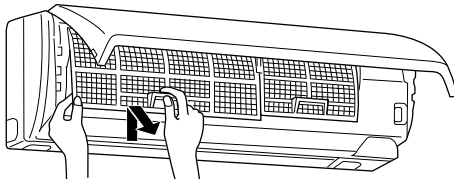

- (2) Remove the air cleaning filter (Blue bellows type) from the catechin air filter.

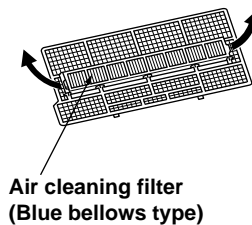

10-2. RoHS PARTS LIST (RoHS compliant)

MS-A09WA

MS-A12WA

1. INDOOR UNIT STRUCTURAL PARTS

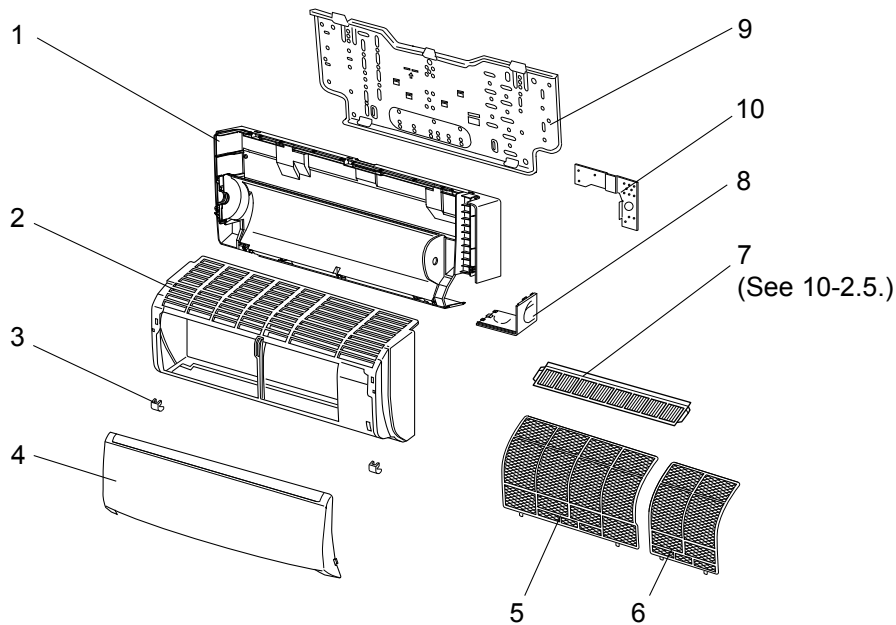

2. ACCESSORY AND REMOTE CONTROLLER

1. INDOOR UNIT STRUCTURAL PARTS

No.	RoHS	Part No.	Part name	Symbol in Wiring Diagram	Q'ty/unit				Remarks
					MS-A09WA		MS-A12WA		
					-	1	-	1	
1	G	E12 A32 234	BOX		1	1	1	1	
2	G	E12 A49 000	PANEL ASSEMBLY		1	1	1	1	Including No.3,4
3	G	E12 913 067	SCREW CAP		2	2	2	2	2 PC/SET
4	G	E12 915 010	FRONT PANEL		1	1	1	1	
5	G	E12 915 100	CATECHIN AIR FILTER (LEFT)		1	1	1	1	
6	G	E12 916 100	CATECHIN AIR FILTER (RIGHT)		1	1	1	1	
7	G	—	AIR CLEANING FILTER		1	1	1	1	MAC-415FT-E
8	G	E12 A32 975	CORNER BOX (RIGHT)		1	1	1	1	
9	G	E12 913 970	INSTALLATION PLATE		1	1	1	1	
10	G	E12 A49 978	CONDUIT PLATE		1		1		

2. ACCESSORY AND REMOTE CONTROLLER

11	G	E12 A49 426	REMOTE CONTROLLER		1	1	1	1	KM06C
	G	E12 C30 426			1	1	1	1	KM07L
12	G	E12 527 083	REMOTE CONTROLLER HOLDER		1	1	1	1	

MS-A09WA

MS-A12WA

3. INDOOR UNIT ELECTRICAL PARTS AND FUNCTIONAL PARTS

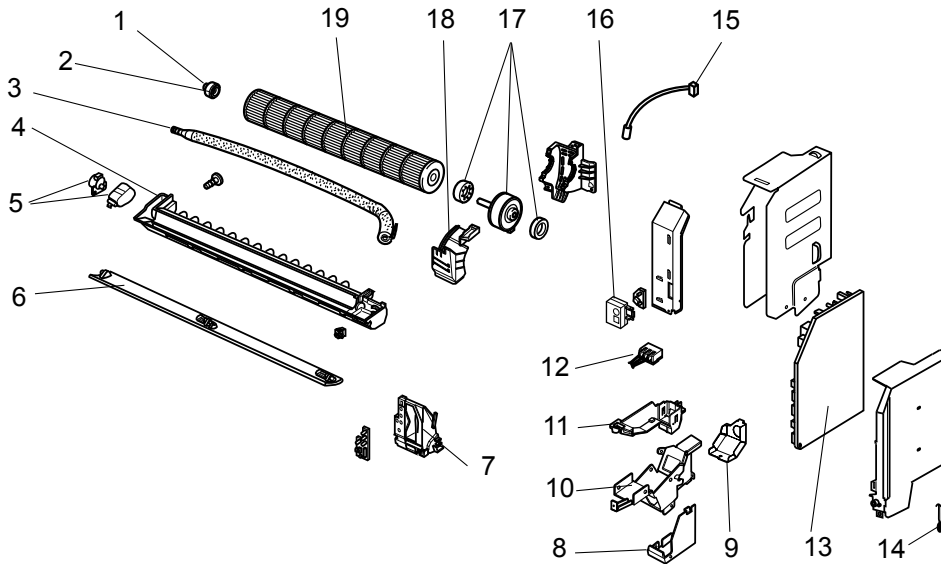

No.	RoHS	Part No.	Part name	Symbol in Wiring Diagram	Q'ty/unit				Remarks
					MS-A09WA		MS-A12WA		
1	G	E12 751 509	BEARING MOUNT		1	- 1	1	- 1	
2	G	E12 001 504	SLEEVE BEARING		1	1	1	1	
3	G	E12 897 702	DRAIN HOSE		1	1	1	1	
4	G	E12 A49 235	NOZZLE ASSEMBLY		1	1	1	1	
5	G	E12 897 303	VANE MOTOR UNIT (HORIZONTAL)	MV	1	1	1	1	UP & DOWN
6	G	E12 913 040	HORIZONTAL VANE		1	1	1	1	
7	G	E12 915 095	POWER MONITOR RECEIVER P.C. BOARD HOLDER		1	1	1	1	
8	G	E12 A49 979	CONDUIT COVER		1		1		
9	G	E12 C30 979	CONDUIT COVER			1		1	
10	G	E12 A49 780	TERMINAL BLOCK COVER		1		1		
	G	E12 C30 780				1		1	
11	G	E12 A49 779	TERMINAL BLOCK HOLDER		1		1		
	G	E12 C30 779				1		1	
12	G	E12 A49 375	TERMINAL BLOCK	TB	1	1	1	1	
13	G	E12 A49 452	ELECTRONIC CONTROL P.C. BOARD *1		1	1			
	G	E12 A50 452					1	1	
14	G	E12 897 308	ROOM TEMPERATURE THERMISTOR	RT11	1	1	1	1	
15	G	E12 897 307	INDOOR COIL THERMISTOR	RT12	1	1	1	1	
16	G	E12 915 782	SWITCH HOLDER		1	1	1	1	
17	G	E12 A49 300	INDOOR FAN MOTOR *2	MF	1	1	1	1	RC0H30-□□
18	G	E12 897 333	MOTOR BAND		1	1	1	1	
19	G	E12 897 302	LINE FLOW FAN		1	1	1	1	

*1 Including SW P.C. BOARD and POWER MONITOR RECEIVER P.C. BOARD

*2 Including FAN MOTOR RUBBER MOUNT (2 PC/SET)

**MS-A09WA
MS-A12WA**

4. INDOOR UNIT HEAT EXCHANGER

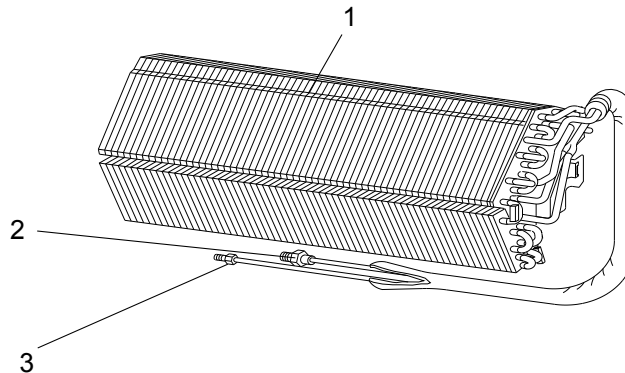

No.	RoHS	Part No.	Part name	Symbol in Wiring Diagram	Q'ty/unit				Remarks
					MS-A09WA		MS-A12WA		
1	G	E12 A49 620	INDOOR HEAT EXCHANGER			- 1		- 1	
	G	E12 70E 620			1				
	G	E12 A50 620					1		
	G	E12 71E 620						1	
2	G	E12 151 666	UNION (GAS)		1	1			ø3/8
	G	E12 155 666					1	1	
3	G	E12 151 667	UNION (LIQUID)		1	1	1	1	ø1/4

5. AIR CLEANING FILTER (ANTI-ALLERGY ENZYME FILTER)

- AIR CLEANING FILTER removes fine dust of 0.01 micron from air by means of static electricity.
- Normal life of AIR CLEANING FILTER is 1 year.
If AIR CLEANING FILTER is to be washed, soak AIR CLEANING FILTER in water (when showing dirt, in lukewarm water) and rinse it delicately, without removing the filter from the frame about once every 3 months.
- Clogged AIR CLEANING FILTER may reduce the air conditioner capacity or cause frost on the air outlet.
- Do not remove or attach AIR CLEANING FILTER during unit operation.

Model	Part No.
MS-A09WA MS-A12WA	MAC-415FT-E

Replacement of the air cleaning filter

(1) Remove the catechin air filter (left one).
The air cleaning filter is not attached to the right side catechin air filter.

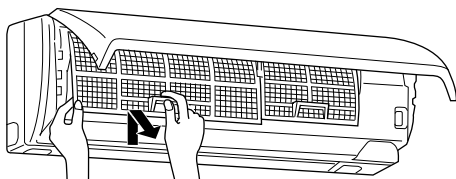

(2) Remove the air cleaning filter (Blue bellows type) from the catechin air filter.

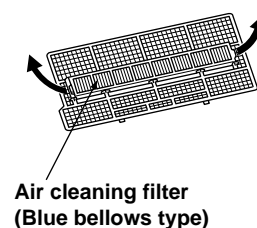

**MS-A09WA
MS-A12WA**

WIRELESS REMOTE CONTROLLER

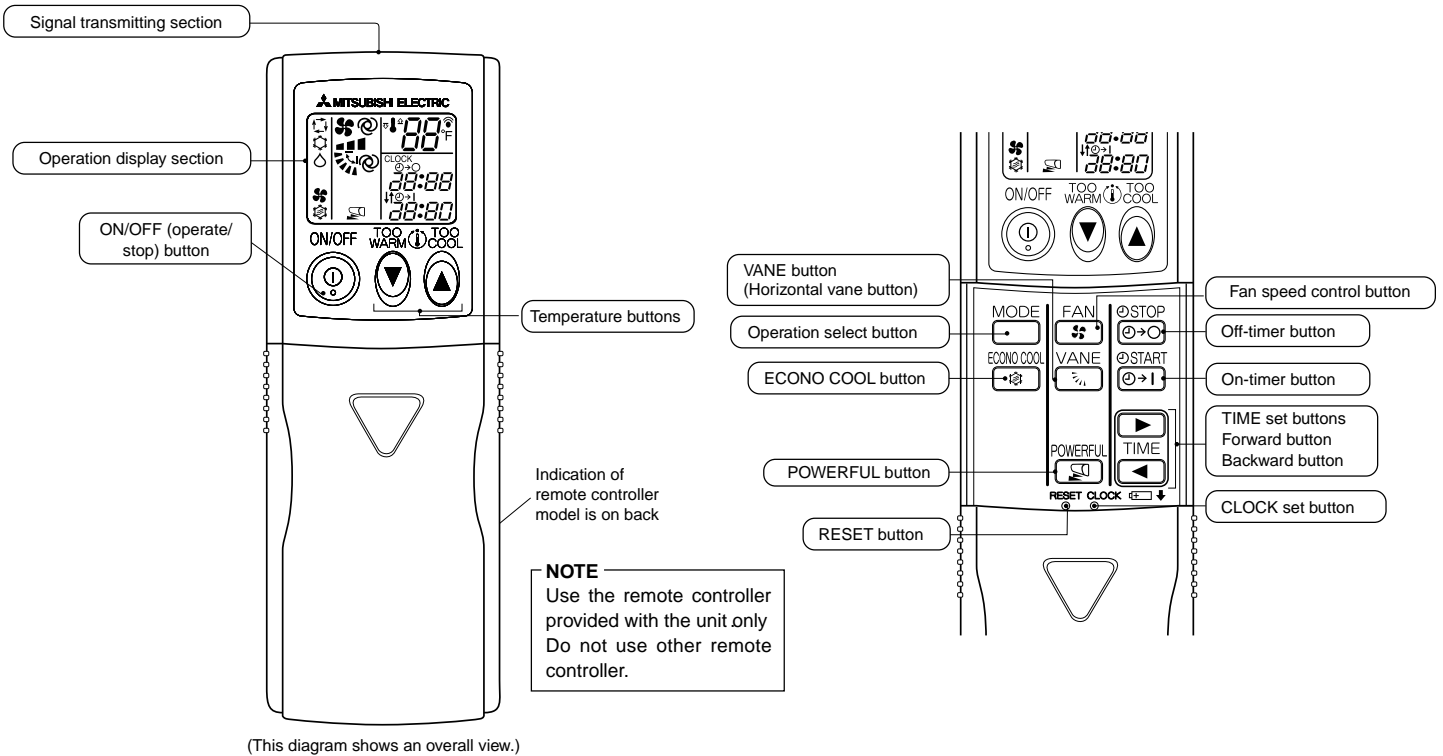

Once the operation mode is set, the same operation mode can be repeated by simply pressing the ON/OFF button ON.
Indoor unit receives the signal with a beep tone.
When the system turns off, 3-minute time delay will operate to protect system from overload and compressor will not restart for 3 minutes.

INDOOR UNIT DISPLAY SECTION

Operation Indicator lamp

The operation indicator at the right side of the indoor unit indicates the operation state.

•The following indication applies regardless of shape of the indication.

Indication	Operation state	Difference between target temperature and room temperature
● ●	This shows that the air conditioner is operating to reach the target temperature. Please wait until the target temperature is obtained.	Approx. 4°F or more
● ○	This shows that the room temperature is approaching the target temperature.	Approx. 4°F or less

- Lighted
- Blinking
- Not lighted

11-1. COOL (❄️) OPERATION

- (1) Press OPERATE/STOP (ON/OFF) button.
OPERATION INDICATOR lamp of the indoor unit turns on with a beep tone.
- (2) Select COOL mode with OPERATION SELECT button.
- (3) Press TEMPERATURE buttons (TOO WARM or TOO COOL button) to select the desired temperature.
The setting range is 61 ~ 88°F.

1. Coil frost prevention

When the temperature of indoor heat exchanger becomes too low, the coil frost prevention mode works. The indoor fan operates at the set speed and the compressor stops. This mode continues until the temperature of indoor heat exchanger rises.

2. Low outside temperature operation

When the outside temperature lowers during cool mode operation, low outside temperature operation starts, and the outdoor fan slows or stops.

11-2. DRY (☀️) OPERATION

- (1) Press OPERATE/STOP (ON/OFF) button.
OPERATION INDICATOR lamp of the indoor unit turns on with a beep tone.
- (2) Select DRY mode with OPERATION SELECT button.
- (3) The set temperature is determined from the initial room temperature.

1. Coil frost prevention

Coil frost prevention is as same as COOL mode. (11-1.1.)

2. Low outside temperature operation

Low outside temperature operation is as same as COOL mode. (11-1.2.)

11-3. FAN (🌀) OPERATION

- (1) Press OPERATE/STOP (ON/OFF) button.
OPERATION INDICATOR lamp of the indoor unit turns ON with a beep tone.
- (2) Select FAN mode with OPERATION SELECT button.
- (3) Select the desired fan speed. When AUTO, it becomes Low.
Only indoor fan operates. Outdoor unit does not operate.

11-4. "I FEEL CONTROL" (☑️) OPERATION

- (1) Press OPERATE/STOP (ON/OFF) button on the remote controller. OPERATION INDICATOR lamp of the indoor unit turns on with a beep tone.
- (2) Select "I FEEL CONTROL" mode with OPERATION SELECT button.
- (3) The operation mode is determined by the room temperature at start-up of the operation.
 - Once the mode is fixed, the mode does not change by room temperature afterwards.
 - Under the ON-TIMER (🕒→|) operation, mode is determined according to the room temperature at the start-up of operation.
- (4) The initial set temperature is decided by the initial room temperature.

Initial room temperature	Model	Initial set temperature
79°F or more	COOL mode of "I FEEL CONTROL"	75°F
77 to 79°F		Initial room temperature minus 4°F
Less than 77°F	DRY mode of "I FEEL CONTROL"	Initial room temperature minus 4°F

(5) TEMPERATURE buttons

In "I FEEL CONTROL" (□) mode, set temperature is decided by the microprocessor based on the room temperature. In addition, set temperature can be controlled by TOO WARM or TOO COOL buttons when you feel too cool or too warm. Each time the TOO WARM or TOO COOL button is pressed, the indoor unit receives the signal and emits a beep tone.

• Fuzzy control

When the TOO COOL or TOO WARM button is pressed, the microprocessor changes the set temperature, considering the room temperature, the frequency of pressing TOO COOL or TOO WARM button and the user's preference to heat or cool. So this is called "Fuzzy control", and works only in "I FEEL CONTROL" mode. In DRY mode of "I FEEL CONTROL", the set temperature doesn't change.



...To raise the set temperature 2 ~ 4°F



...To lower the set temperature 2 ~ 4°F

11-5. AUTO VANE OPERATION

1. Horizontal vane

(1) Vane motor drive

These models are equipped with a stepping motor for the horizontal vane. The rotating direction, speed, and angle of the motor are controlled by pulse signals (approx. 12 V) transmitted from indoor microprocessor.

(2) The horizontal vane angle and mode change as follows by pressing VANE CONTROL button.



(3) Positioning

The vane is once pressed to the vane stopper to confirm the standard position and then set to the desired angle.

Confirming of standard position is performed in the following cases.

- (a) When the operation starts or finishes (including timer operation).
- (b) When the test run starts.
- (c) When multi-standby starts or finishes.

(4) VANE AUTO (@) mode

In VANE AUTO mode, the microprocessor automatically determines the vane angle and operation to make the optimum room-temperature distribution.

In COOL, DRY and FAN operation
Vane angle is fixed to Horizontal position.

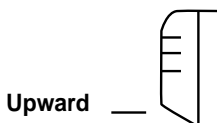

(5) STOP (operation OFF) and ON-TIMER standby

In the following cases, the horizontal vane returns to the closed position.

- (a) When OPERATE/STOP (ON/OFF) button is pressed (POWER OFF).
- (b) When the operation is stopped by the emergency operation.
- (c) When ON-TIMER is ON standby.

(6) Dew prevention

During COOL or DRY operation with the vane angle at Angle 2 ~ 4 when the compressor cumulative operation time exceeds 1 hour, the vane angle automatically changes to Angle 1 for dew prevention.

(7) SWING MODE (↕)

By selecting SWING mode with VANE CONTROL button, the horizontal vane swings vertically. The remote controller displays "↕".

(8) To change the airflow direction not to blow directly onto your body.

To change the airflow direction	When to use this function?	COOL/DRY
Pressing and holding VANE CONTROL button for 2 seconds or more, the horizontal vane reverses and moves horizontal position.  Horizontal position	Use this function if you don't want the air from the indoor unit to blow directly onto your body. <ul style="list-style-type: none"> Depending on the shape of the room, the air may blow directly onto your body. Press VANE CONTROL button again to return the vane to the previously-set position. 	The air conditioner starts the cooling or drying operation approx. 3 minutes after the vane has moved to the horizontal position. <ul style="list-style-type: none"> When VANE CONTROL button is pressed again, the vane returns to the previously-set position and the air conditioner starts the cool or dry operation in approx. 3 minutes.

NOTE :

- If you make the airflow not to blow directly onto your body by pressing VANE CONTROL button, the compressor stops for 3 minutes even during the operation of the air conditioner.
- The air conditioner operates with Very Low speed until the compressor turns on again.

(9) ECONO COOL (🌿) operation (ECONOMical operation)

When ECONO COOL button is pressed in COOL mode, set temperature is automatically set 3.6°F higher than that in COOL mode.

Also the horizontal vane swings in various cycle.

SWING operation makes you feel cooler than set temperature. So, even though the set temperature is higher than that in COOL mode, the air conditioner can keep comfort. As a result, energy can be saved.

ECONO COOL operation is cancelled when ECONO COOL button is pressed once again. Plessing VANE CONTROL button or POWERFUL button, or changing to other operation mode also cancels ECONO COOL operation.

(10) POWERFUL (🔥) operation

The air conditioner automatically adjusts the fan speed and the set temperature, and operates the POWERFUL mode. The POWERFUL mode is automatically released 15 minutes after operation starts, and the operation mode returns to the mode prior to POWERFUL operation.

11-6. TIMER OPERATION

1. How to set the timer

- (1) Press OPERATE/STOP (ON/OFF) button to start the air conditioner.
- (2) Check that the current time is set correctly.

NOTE : Timer operation will not work without setting the current time. Initially "0:00" blinks at the current time display of TIME MONITOR, so set the current time correctly with CLOCK SET button.

How to set the current time

- (1) Press the CLOCK set button.
 - (2) Press the TIME SET buttons (▶ and ◀) to set the current time.
 - Each time FORWARD button (▶) is press, the set time increases by 1 minute, and each time BACKWARD button (◀) is press, the set time decreases by 1 minute.
 - Pressing those buttons longer increases / decreases the set time by 10 minutes.
- Press the CLOCK set button.

ON timer setting

- (1) Press ON-TIMER button (START/ON) during operation.
- (2) Set the time of the timer using TIME SET buttons (▶ and ◀). *

OFF timer setting

- (1) Press OFF-TIMER button (STOP/OFF) during operation.
- (2) Set the time of the timer using TIME SET buttons (▶ and ◀). *
 - * Each time FORWARD button (▶) is pressed, the set time increases by 10 minutes; each time BACKWARD button (◀) is pressed, the set time decreases by 10 minutes.

2. Cancel

To cancel ON timer, press ON-TIMER button (START/ON).

To cancel OFF timer, press OFF-TIMER button (STOP/OFF).
TIMER is cancelled and the display of set time disappears.

PROGRAM TIMER

- OFF timer and ON timer can be used in combination. The timer of the set time that is reached first will operate first.
- "↓" and "↑" display shows the order of OFF timer and ON timer operation.

(Example 1) The current time is 8:00 PM.

The unit turns off at 11:00 PM, and on at 6:00 AM.

(Example 2) The current time is 11:00 AM.

The unit turns on at 5:00 PM, and off at 9:00 PM.

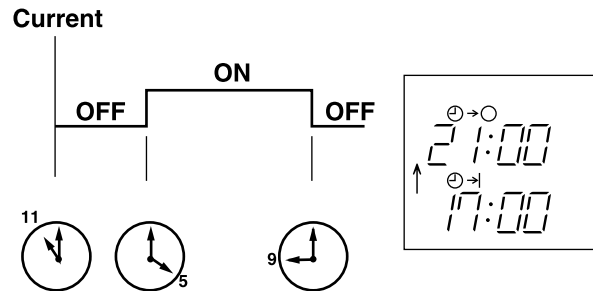
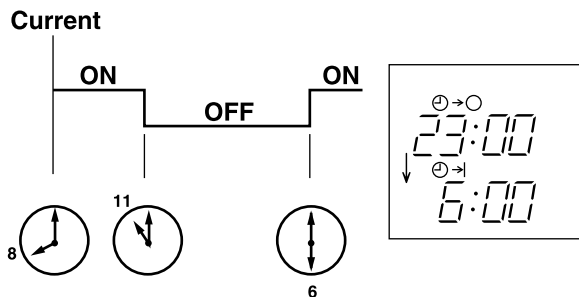

NOTE : If the main power is turned off or a power failure occurs while AUTO START/STOP timer is active, the timer setting is cancelled. As these models are equipped with an auto restart function, the air conditioner starts operating with timer cancelled when power is restored.

11-7. EMERGENCY/TEST OPERATION

In case of test run operation or emergency operation, use EMERGENCY OPERATION switch on the front of the indoor unit. Emergency operation is available when the remote controller is missing, has failed or the batteries of the remote controller run down. The unit will start and OPERATION INDICATOR lamp will light.

The first 30 minutes of operation is the test run operation. This operation is for servicing. The Indoor fan speed runs at High speed and the system is in continuous operation (with thermostat ON).

After 30 minutes of test run operation the system shifts to EMERGENCY COOL with a set temperature of 75°F. The fan speed shifts to Med..

All protective operations such as the coil frost prevention works even in emergency operation.

In the test run or emergency operation, the horizontal vane operates in VANE AUTO (Ⓢ) mode.

Emergency operation continues until EMERGENCY OPERATION switch is pressed once or twice or the unit receives any signal from the remote controller. In case of latter normal operation will start.

NOTE : Do not press EMERGENCY OPERATION switch during normal operation.

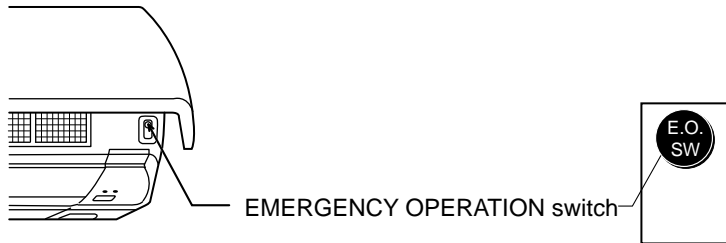

Operation mode	COOL
Set temperature	75°F
Fan speed	Med.
Horizontal vane	Auto

The operation mode is indicated by the Operation Indicator lamp as following

Operation Indicator lamp

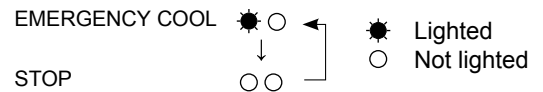

11-8. CHANGING TEMPERATURE INDICATION (°F/°C)

MS-A•WA-1

The preset unit is °F.
 Press RESET button while the temperature buttons are pressed.

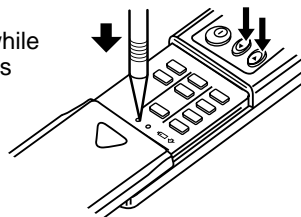

Press RESET button gently using a thin stick.

MITSUBISHI ELECTRIC CORPORATION

HEAD OFFICE: TOKYO BUILDING, 2-7-3, MARUNOUCHI, CHIYODA-KU, TOKYO 100-8310, JAPAN

© Copyright 2006 MITSUBISHI ELECTRIC ENGINEERING CO.,LTD

Issued: May 2018. No. OB448 REVISED EDITION-D

Issued: Oct. 2008. No. OB448 REVISED EDITION-C 5

Issued: Jun. 2008. No. OB448 REVISED EDITION-B 6

Issued: May 2007. No. OB448 REVISED EDITION-A 7

Published: Mar. 2006. No. OB448 7

Made in Japan

Specifications subject to change without notice.