

# Service Manual

Applicable Models	Model Code
UR-PC160E1-DQ	22033210000004



(The picture is only for reference, and specific appearance and configuration are subject to the real product)

Prepared by	R&D: Chen Feixiang
Reviewed by	QA: Wang Tao SVC: Chen Lei
Approved by	R&D: Zhang Huawei SVC: Guang Taoshuai



### **Important Safety Notice**

The Maintenance Manual is only for the use of maintenance personnel with certain experience and background in electrical, electronic and mechanical field.

Any attempt to repair main devices may lead to personal injury and property loss.

Manufacturers or distributors are not responsible for the content of the Manual and interpretation thereof.

### **Midea Refrigerators**

Technical Maintenance Manual

Copyright ©2016

All rights reserved. Replication of all or part of the Manual in any forms shall not be allowed without written approval by the Overseas Sales Corporation of Midea Refrigerators.

## **Contents**

1.Safety Warning Code..... 5

1.1	Warning for operation safety .....	5
1.2	Safety instruction for refrigerant .....	8
2.	Description for product features .....	9
3.	Installation and commissioning.....	10
3.1	Handling .....	10
3.2	Door Disassembly and Assembly(None).....	10
3.3	Installation location .....	10
3.4	Leveling of the refrigerator .....	11
3.5	Door reversal(None).....	11
3.6	Installation of handle(None).....	11
3.7	Installation of door lock(None) .....	11
3.8	Adjustment to level the door(None) .....	11
4.	Terms .....	11
4.1	Definition of model(None).....	11
4.2	Location of nameplate .....	11
(The picture is only for reference, and specific appearance and configuration are subject to the real product)		
5.	Product specification .....	11
5.1	Type specification (None) .....	12
5.2	Electrical parameters .....	12
5.3	Inside temperature .....	13
5.4	Defrosting parts (None) .....	13
5.5	Circuit diagram.....	13
6.	Internal view and dimension .....	14
6.1	Main parts and their names .....	14
6.2	External dimension.....	14
(The picture is only for reference, and specific appearance and configuration are subject to the real product)		
7.	Refrigerating piping system and circulating route of cooling air .....	15
7.1	Refrigerating piping system .....	16
7.2	Circulating route of cooling air .....	16
8.	Dismantling of parts .....	17
8.2	Parts inside the wine cabinet .....	17
8.3	Light system(None).....	18
8.4	Air duct components refrigerating chamber and fan motor.....	18
8.5	Air duct components in freezing chamber and fan motor(None) .....	18
8.6	Evaporator and temperature sensing system .....	18
8.7	Compressor case.....	19
8.9	Bar counter(None).....	23
8.10	Water dispenser(None) .....	23
8.11	Ice maker(None).....	23
9.	Function and operation.....	24
9.1	operation panel .....	24
9.2	Temperature control .....	24
9.3	Alarm(None) .....	24
9.4	Failure code and solutions .....	24

9.5Defrost function.....	25
The defrosting of evaporator is activated when the temperature monitored by defrosting sensor is below setted point., compressor switching off, following the temperature rise, the frost on evaporator becomes water, and the water flow into the evaporating pan via the draining system, the water in evaporating pan evaporate away finally.	
9.6Compressor fan control (None) .....	25
9.7Self-diagnosis (None).....	25
10.Circuit description .....	26
10.1 Power Supply .....	26
10.2Door trip test circuit(None) .....	27
10.3Temperature test circuit .....	27
In inspection, unplug the wiring connector of sensor( picture10.4, socket 1&2 ), adjust the multi meter to the gear of resistance detection, put the red probe and black probe on the corresponding pins to detect the resistance value of sensor, then check with resistance table (10.8) to identify whether the sensor is damaged.	
10.4Fan motor circuit of the freezing chamber(None).....	27
10.5Refrigerator fan motor circuit.....	28
The fan motor of refrigerator runs with the compressor, at this moment check if there is 12V voltage between FAN pin and GND, in normal running, FAN is high-level input, there is 6V more voltage between FAN pins. if there is no voltage detected when the compressor is running, replace the fan motor or main PCB by new one, in test, adjust the multi meter to gear of DC voltage, put the black probe on the pin of GND, and put the red probe on the pin of FAN, when the motor is running, there should be 6V more voltage detected; when the fan motor is in shutdown, the detected voltage should be 0V	
10.6Condensing fan motor circuit (None) .....	28
10.7Damper motor circuit (None) .....	28
10.8 (R/T) Resistance value of the sensor (R/T).....	28
11.Trouble shooting Method .....	29
11.1No cooling .....	29
11.2No working of compressor .....	30
11.3Inside frosting, no defrosting.....	31
11.5Lights inside the refrigerator don't light up (None) .....	33
11.6Air duct not operated(None).....	33
11.7Fan failure (None) .....	33
11.8Defective defrost circuit (None) .....	33
11.9Noise.....	33
12. Figures and details of repair parts/Documents are provided separately) .....	34
12.1Figures.....	34
12.2List of parts and components.....	34
13Appendix:.....	34
13.1Electrical Schematic Diagram(None).....	34
13.2Refrigerator maintenance tooling and equipment and material.....	34

## 1.Safety Warning Code

### 1.1 Warning for operation safety

## Important Safety Instructions

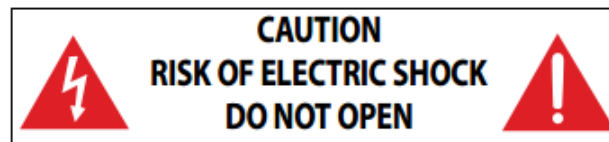

This symbol indicates that dangerous voltage constituting a risk of electric shock is present within your freezer.



This symbol indicates that there are important operating and maintenance instructions in the literature accompanying your freezer.

### **WARNING**

- 1 Read these instructions.
- 2 Keep these instructions.
- 3 Heed all warnings.
- 4 Follow all instructions.
- 5 Do not use this appliance near water.
- 6 Clean only with a damp cloth.
- 7 Do not block any ventilation openings.
- 8 Install in accordance with the manufacturer's instructions.
- 9 Do not install near any heat sources, such as radiators, heat registers, stoves, or other apparatus that produce heat.
- 10 Do not defeat the safety purpose of the polarized or grounding-type plug. A polarized plug has two blades with one wider than the other. A grounding type plug has two blades and a third grounding prong. The wide blade or the third prong are provided for your safety. If the provided plug does not fit into your outlet, consult an electrician for replacement of the obsolete outlet.
- 11 Protect the power cord from being walked on or pinched, particularly at plugs, convenience receptacles, and the point where they exit from the appliance.
- 12 Do not attempt to modify or extend the power cord of this appliance.
- 13 Unplug this appliance during lightning storms or when it will not be used for long periods of time.
- 14 Make sure that the available AC power matches the voltage requirements of this appliance.

- 15 Do not handle the plug with wet hands. This could result in an electric shock.
- 16 Unplug the power cord by holding the plug, never by pulling the cord.
- 17 Do not turn the appliance on or off by plugging or unplugging the power cord.
- 18 Refer all servicing to qualified service personnel. Servicing is required when the appliance has been damaged in any way, such as the power-supply cord or plug is damaged, liquid has been spilled or objects have fallen into the appliance, the appliance has been exposed to rain or moisture, does not operate normally, or has been dropped.
- 19 To reduce the risk of fire or electric shock, do not expose this appliance to rain, moisture, dripping, or splashing, and no objects filled with liquids should be placed on top of it.
- 20 Do not use extension cords or ungrounded (two prong) adapters.
- 21 This appliance is not intended for use by persons (including children) with reduced physical, sensory or mental capabilities, or lack of experience and knowledge, unless they have been given supervision or instruction concerning use of the appliance by a person responsible for their safety.
- 22 Children should be supervised to ensure that they do not play with the appliance.
- 23 If the supply cord is damaged, it must be replaced by the manufacturer, its service agent, or similarly qualified person, in order to avoid a hazard.
- 24 Take off the doors and leave the shelves in place so that children may not easily climb inside.



## WARNING

### Electric Shock Hazard

**Failure to follow these instructions can result in electric shock, fire, or death.**

- 1 **WARNING**—Keep ventilation openings, in both the freezer and the built-in structure, clear of obstruction.
- 2 **WARNING**—Do not touch the interior of the freezer with wet hands. This could result in frost bite.
- 3 **WARNING**—Do not use mechanical devices or other means to accelerate the defrosting process, other than those recommended by the manufacturer.
- 4 **WARNING**—Do not damage the refrigerant circuit.

- 5 **WARNING**—Do not damage the refrigerant tubing when handling, moving, or using the freezer.
- 6 **WARNING–DANGER**—Never allow children to play with, operate, or crawl inside the freezer.  
Risk of child entrapment. Before you throw away your old freezer:
  - 1) Take off the doors
  - 2) Leave the shelves in place so that children may not easily climb inside
- 7 Unplug the freezer before carrying out user maintenance on it.
- 8 This freezer can be used by children age eight years and older and persons with reduced physical or mental capabilities or lack of experience and knowledge if they are given supervision or instruction concerning the use of the freezer in a safe way and understand the hazards involved. Children should not play with the freezer. Cleaning and maintenance should not be performed by children without supervision.
- 5 **WARNING**—Do not damage the refrigerant tubing when handling, moving, or using the freezer.
- 6 **WARNING–DANGER**—Never allow children to play with, operate, or crawl inside the freezer.  
Risk of child entrapment. Before you throw away your old freezer:
  - 1) Take off the doors
  - 2) Leave the shelves in place so that children may not easily climb inside
- 7 Unplug the freezer before carrying out user maintenance on it.
- 8 This freezer can be used by children age eight years and older and persons with reduced physical or mental capabilities or lack of experience and knowledge if they are given supervision or instruction concerning the use of the freezer in a safe way and understand the hazards involved. Children should not play with the freezer. Cleaning and maintenance should not be performed by children without supervision.
- 9 If a component part is damaged, it must be replaced by the manufacturer, its service agent, or similar qualified persons in order to avoid a hazard.
- 10 Please dispose of the freezer according to local regulations as the freezer contains flammable gas and refrigerant.
- 11 Follow local regulations regarding disposal of the freezer due to flammable refrigerant and gas. All refrigeration products contain refrigerants, which under the guidelines of federal law must be removed before disposal. It is the consumer's responsibility to comply with federal and local regulations when disposing of this product.

- 12 This freezer is intended to be used in household and similar environments.
- 13 Do not store or use gasoline or any flammable liquids inside or in the vicinity of this freezer.
- 14 Do not use extension cords or ungrounded (two-prong) adapters with this freezer. If the power cord is too short, have a qualified electrician install an outlet near the freezer. Use of an extension cord can negatively affect the freezer's performance.

### Grounding requirement

This freezer must be grounded. This freezer is equipped with a cord having a grounding wire with a grounding plug. The plug must be inserted into an outlet that is properly installed and grounded.

Improper use of the grounding plug can result in a risk of electric shock. Consult a qualified electrician or service person if the grounding instructions are not completely understood, or if doubt exists as to whether the freezer is properly grounded.

### 1.2 Safety instruction for refrigerant

**⚠ WARNING**  **Explosion Hazard.**

Keep flammable materials and vapors, such as gasoline, away from freezer. Failure to do so can result in fire, explosion, or death.

DANGER—Risk of Fire or Explosion. Flammable Refrigerant Used. To Be Repaired Only By Trained Service Personnel. Do Not Use Mechanical Devices. Do Not Puncture Refrigerant Tubing.  
 CAUTION—Risk of Fire or Explosion. Flammable Refrigerant Used. Consult Repair Manual/Owner's Guide Before Attempting To Service This Product. All Safety Precautions Must be Followed.  
 CAUTION—Risk of Fire or Explosion. Dispose of Properly In Accordance With Federal Or Local Regulations. Flammable Refrigerant Used.  
 CAUTION—Risk of Fire or Explosion Due To Puncture Of Refrigerant Tubing; Follow Handling Instructions Carefully. Flammable Refrigerant Used.



## **2. Description for product features**

This product is provided with following features:



(The picture is only for reference, and specific appearance and configuration are subject to the real product)

- 1) Integrative refrigeration chamber
- 2) Electronic control
- 3) Polisher black tower with stainless steel trim
- 4) Holds most 1/2 and 1/4 size kegs

### 3. Installation and commissioning

#### 3.1 Handling

- 1) Protect the refrigerator in moving it  
Same as shown as left photo, please move it by handcart with cushion
- 2) Remove all packing materials and bottom cushion, then move into house for placement
- 3) After moving it to appropriate location, wait for 2 hours before power on.



#### 3.2 Door Disassembly and Assembly(None)

The refrigerator door needs to be dismantled if it cannot enter the room in the whole.

#### 3.3 Installation location

Location that is easy for ventilation shall be chosen to facilitate heat dissipation, enhance its performance and reduce the energy consumption.

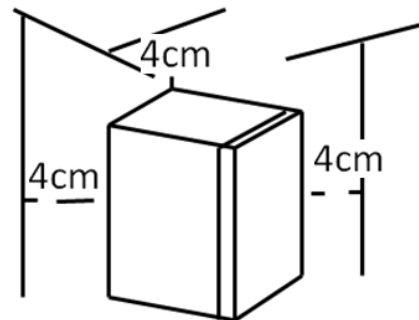

### 3.4 Leveling of the refrigerator

If the refrigerator cannot be placed steadily, adjust the footing to level it.

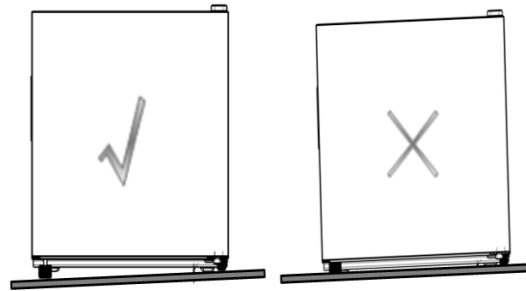

### 3.5 Door reversal(None)

### 3.6 Installation of handle(None)

### 3.7 Installation of door lock(None)

### 3.8 Adjustment to level the door(None)

## 4. Terms

### 4.1 Definition of model(None)

### 4.2 Location of nameplate

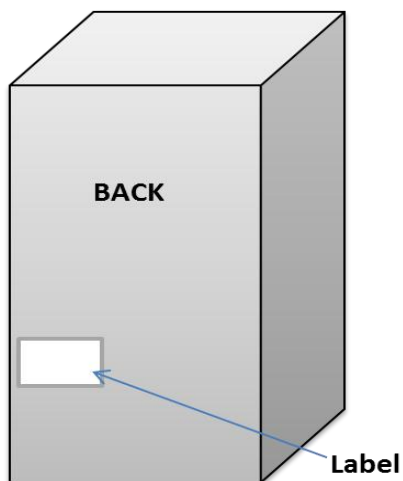

(The picture is only for reference, and specific appearance and configuration are subject to the real product)

## 5. Product specification

### 5.1 Type specification (None)

### 5.2 Electrical parameters

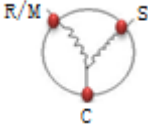
Product Name		UR-PC160E1-DQ		/	/
Product Code		22033210000004		/	/
Name	Item	Type	Specification	Specification	Specification
Compressor	Compressor	/	EZ59E1C-1SU	/	/
	Starter	PTC	QP2-4R7	/	/
	Overload protector	OLP	DRB18R61A1	/	/
	Winding resistance of compressor wiring terminal		Rmc: $8.8 \pm 7\% \Omega$ Rsc: $7.5 \pm 7\% \Omega$ Rms = Rmc + Rsc (20°C)	/	/
Motor	Fan motor of the freezing chamber	/	12V/4W	/	/
	Ventilation door of the refrigerating chamber	/	/	/	/
	Condensation fan	/	/	/	/
Light inside the refrigerator	Lights inside the refrigerating chamber	/	/	/	/
	Switch of the refrigerator door	/	/	/	/
	Indicator lamp	/	/	/	/

### 5.3 Inside temperature

Temperature tolerance  $\leq 2^{\circ}\text{C}$

Compartment	The highest ( °C)	Lowest ( °C)
Refrigerating	7	-3

### 5.4 Defrosting parts (None)

### 5.5 Circuit diagram

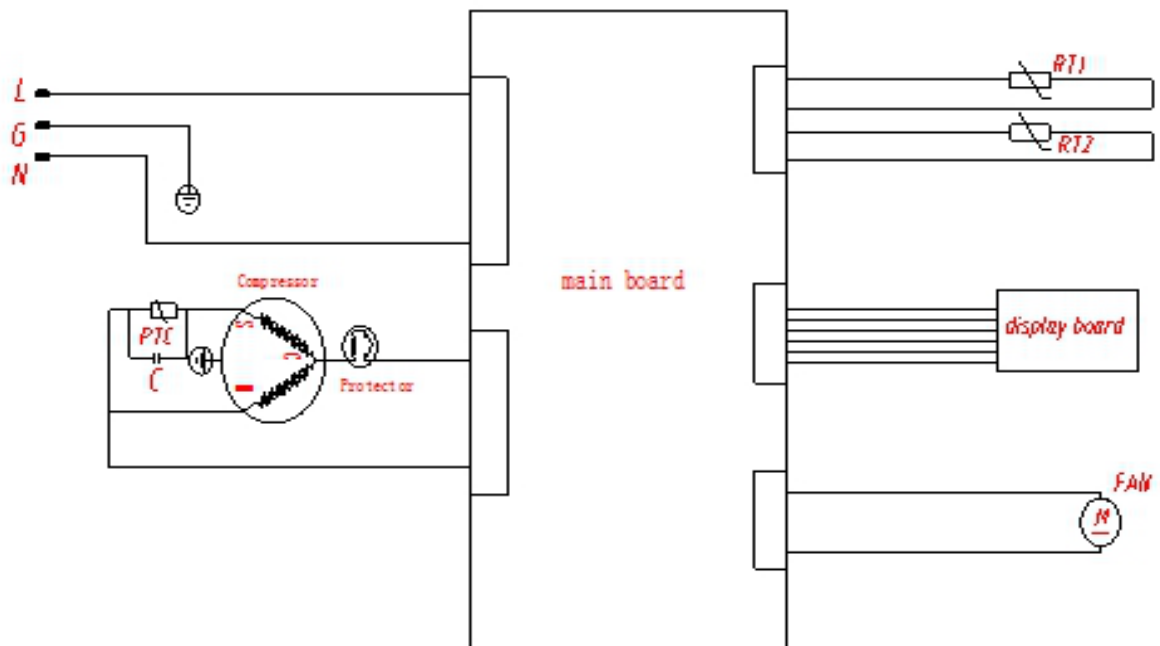

## 6. Internal view and dimension

### 6.1 Main parts and their names

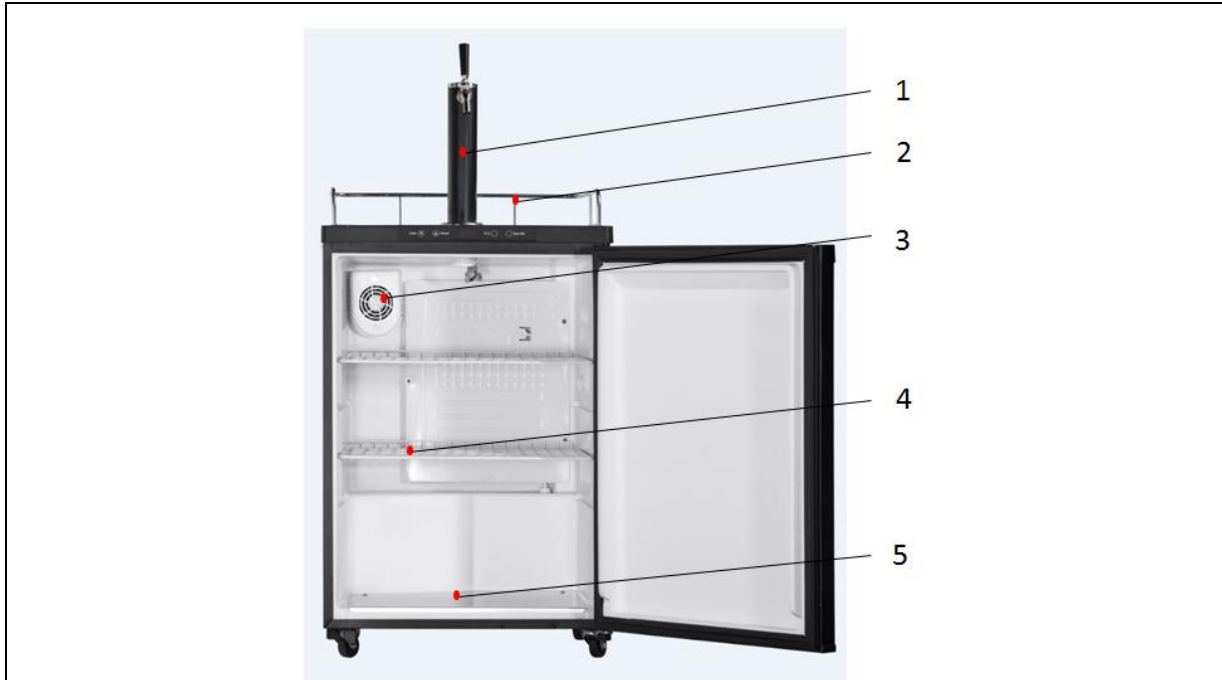

(The picture is only for reference, and specific appearance and configuration are subject to the real product)

1. Beer tower	4. Shelf
2. Guardrail	5. Beer can bottom pad
3. Fan	

### 6.2 External dimension

Front view	Side view
------------	-----------

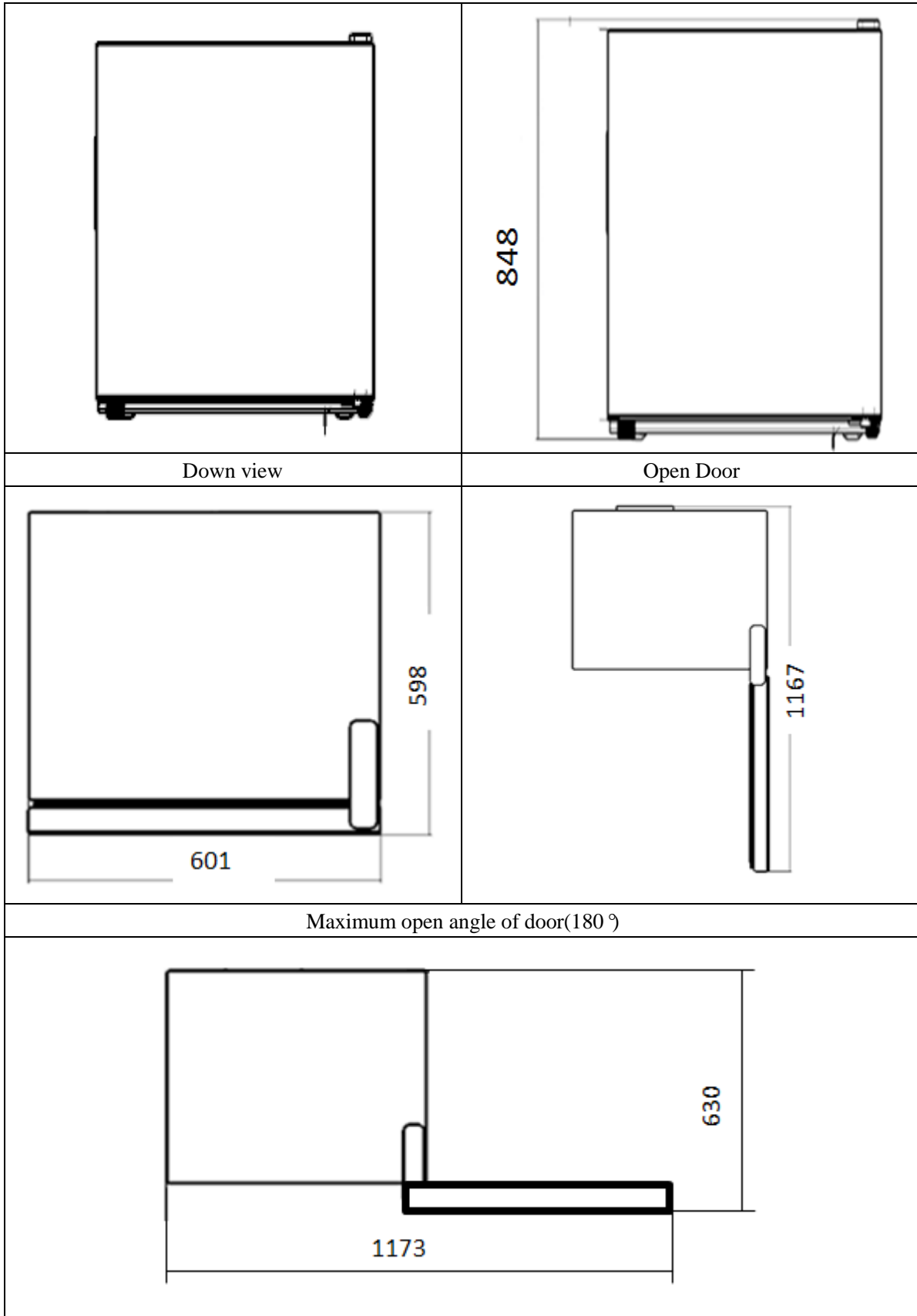

(The picture is only for reference, and specific appearance and configuration are subject to the real product)

## 7. Refrigerating piping system and circulating route of cooling air

### 7.1 Refrigerating piping system

1Compressor→2Exhaust transition pipe→3condenser→4Dry filter →5Capillary tube→6Evaporator→7Return transition pipe→1Compressor

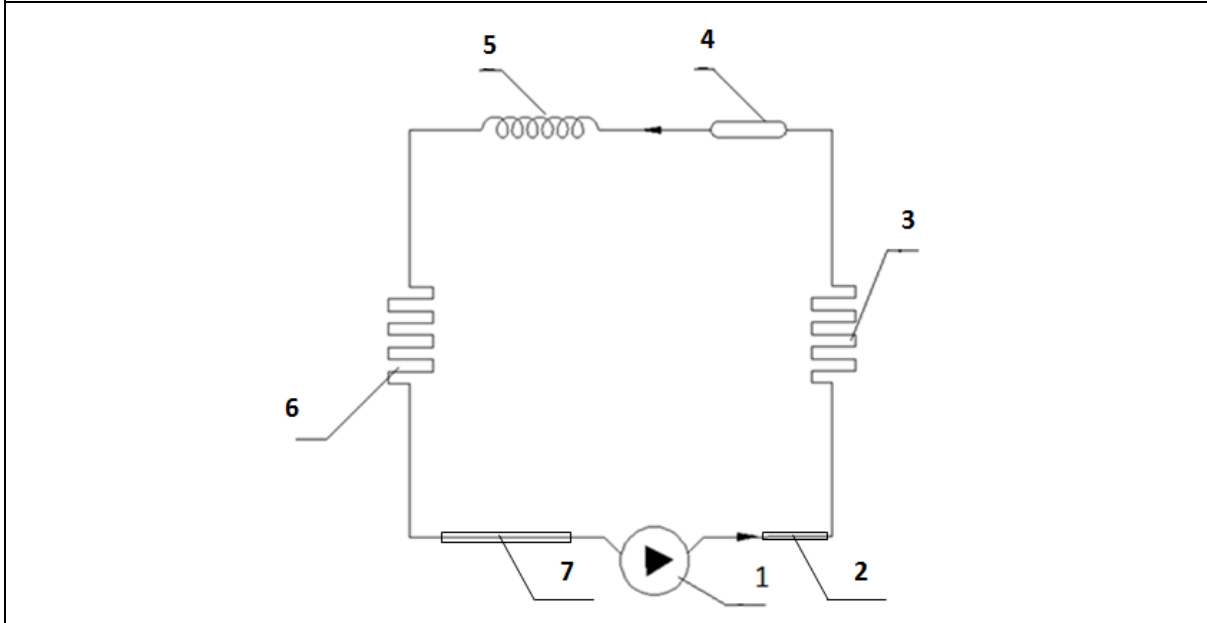

(The picture is only for reference, and specific appearance and configuration are subject to the real product)

### 7.2 Circulating route of cooling air

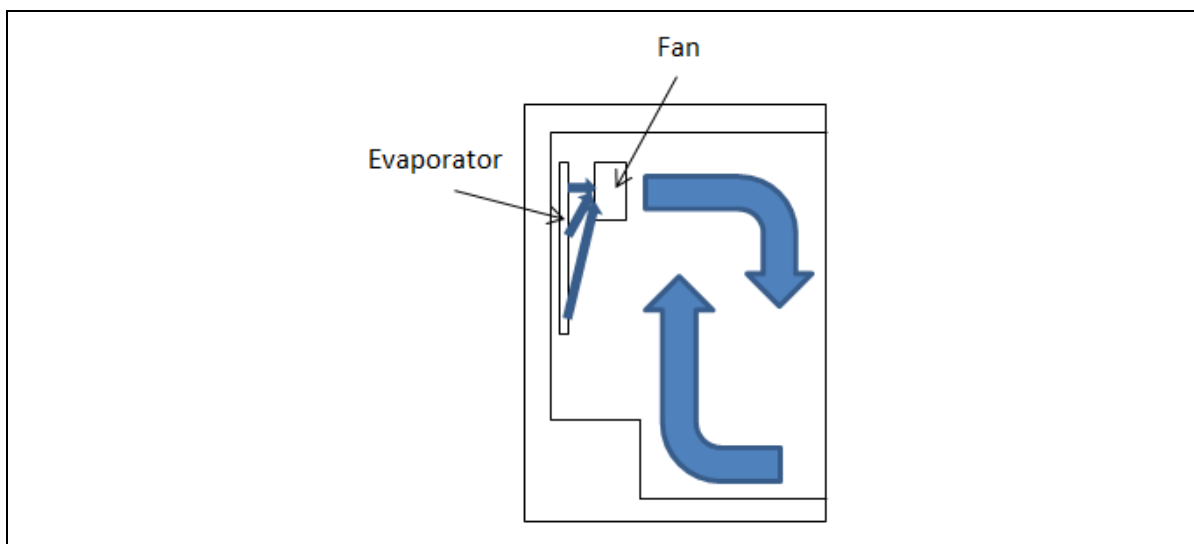



## 8.Dismantling of parts

### 8.1 Parts on the door

<b>Door seal</b>	
<p>Door seal is installed into door liner groove.</p> <ol style="list-style-type: none"> <li>1) Open the wine cabinet door;</li> <li>2) Take the door seal ① out of door liner.</li> </ol>	

### 8.2 Parts inside the wine cabinet

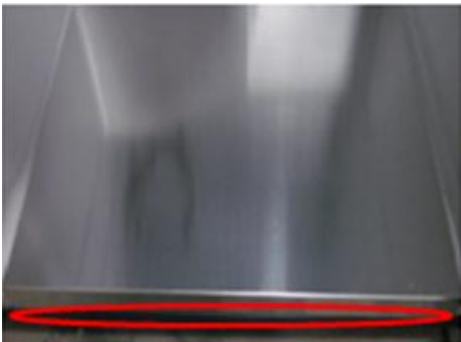
<b>Shelf</b>	
<ol style="list-style-type: none"> <li>1) Lift up the shelf with a proper force and pull it out towards yourself.</li> </ol>	
<b>CO2 can mounting</b>	
<ol style="list-style-type: none"> <li>1) Take down the two screws using a screwdriver and get out the mounting.</li> </ol>	
<b>Beer can bottom pad</b>	
<ol style="list-style-type: none"> <li>1) Push up the beer can bottom pad from the gap between the shell and the liner and take it out.</li> </ol>	

8.3 Light system(None)

8.4 Air duct components refrigerating chamber and fan motor



Air duct components refrigerating chamber	None
<b>Fan motor of air duct</b>	
<p>1) Use a screwdriver to take down the screws on fan. Remove the connecting harness terminals linking the fan and cabinet and take down the fan. Remove the connecting harness terminals linking the fan and cabinet and take down the fan. Remove the cover. Take out the fan from the mounting box</p>	

8.5 Air duct components in freezing chamber and fan motor(None)

Disassembly and installation of Air duct	None
Fan motor of air duct	None



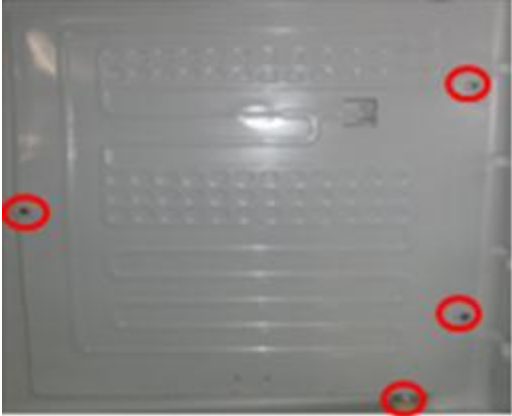

8.6 Evaporator and temperature sensing system

Evaporator in freezing chamber	None
Components on the evaporator	
Defrost thermostat	None
Fuse	None
Defrost sensor	None
Defrost heater	None
Evaporator in refrigerating chamber	

<p>1) Take down screws and gaskets on the evaporator.</p> <p>2) Remove the welding on inlet and outlet tubes.</p>	
<p><b>Components on the evaporator</b></p>	
<p><b>Defrost sensor</b> The defrost sensor is located on back of the evaporator.</p>	<p>Not replace</p> 
<p><b>Sensor</b></p>	
<p>Sensor in freezing chamber</p>	<p>None</p>
<p><b>Sensor in refrigerating chamber</b></p>	
<p>1) To remove the sensor cover, you may squeeze it up and down; Take the sensor out from card slot.</p>	
<p>Sensor in Variable temperature chamber</p>	<p>None</p>
<p>Ambient temperature sensor</p>	<p>None</p>

**8.7 Compressor case**

<p><b>Rear cover and compressor case</b></p>
--

<p>Rear cover and compressor case</p> <p>1) Remove by cross screwdriver the screws fixing back cover plate of compressor chamber anticlockwise</p> <p>2) Take the back cover plate of compressor chamber upward.</p>	
<p><b>Terminal box of the compressor</b></p>	
<p>1) <b>Remove the screws</b> Two screws outside One screw inside</p>	
<p><b>Remove the clipping strip</b> Slowly pull it out</p>	
<p><b>1. Remove the protective cover</b></p> <p>1) Pry the protective cover slowly from the upper part,</p> <p>2) Pull it out and remove it.</p>	
<p><b>2. Remove the starter and protector</b></p> <p>Unplug the starter and protector (you can use a screwdriver to pry it slowly)</p>	
<p><b>1. The reverse process can complete installation.</b></p>	<p>/</p>
<p>Piping system in the compressor case</p>	

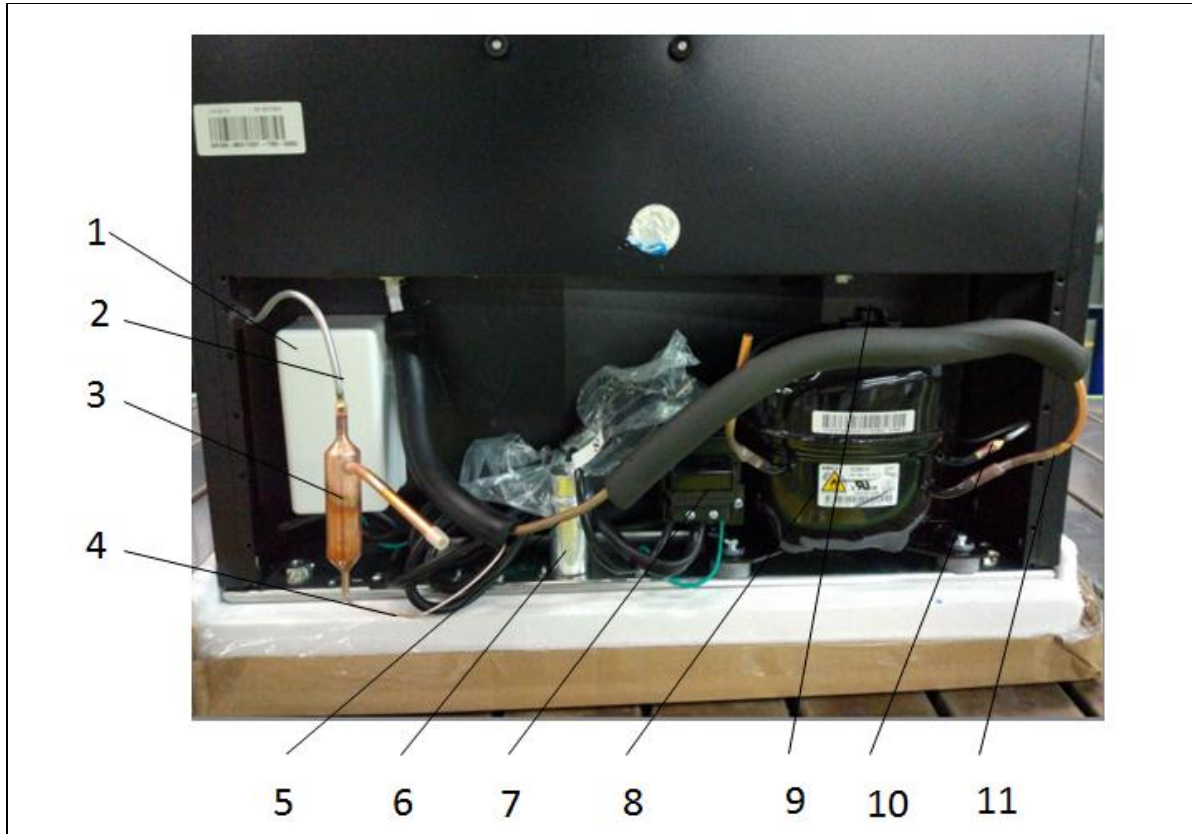

1	Main control board box	6	Capacitor
2	Condenser-1(in)	7	Compressor cover
3	Drier	8	Compressor
4	Capillary Tube	9	drain tray
5	Transition pipe	10	Condenser-2(out)
		11	Suction connection Pipe

<b>Condenser fan motor</b>	
Fan motor	None
Standby condenser	None

8.8 Temperature control panel

1. Remove the two screws linking the temperature control board mounting box to the box

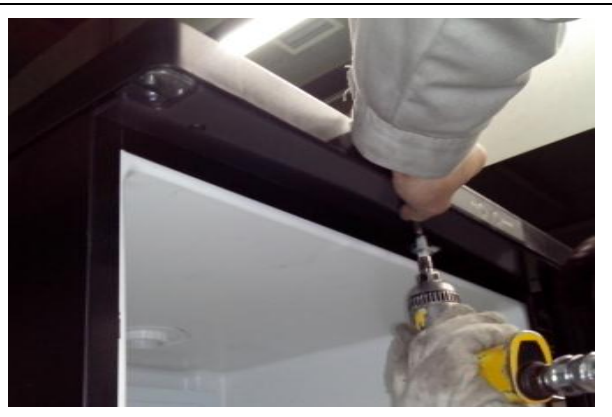

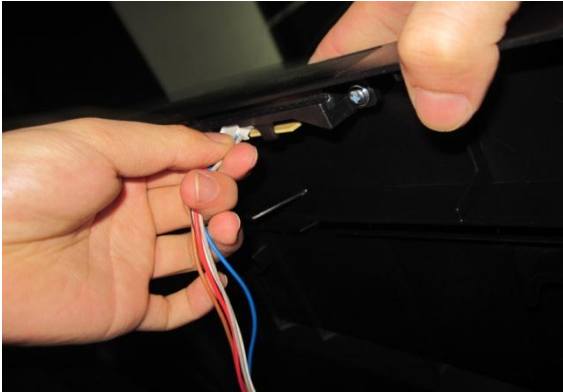
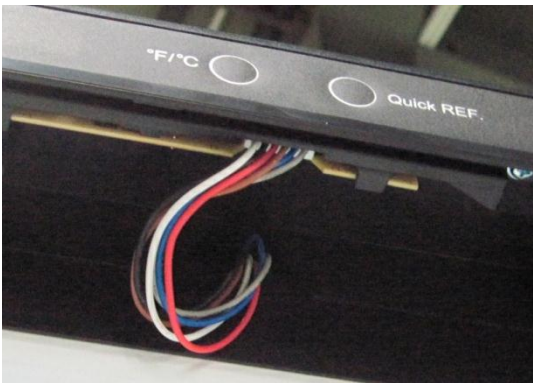
<p>2 Disconnect the connector</p>	
<p>3. Remove the temperature control panel</p>	

▪ 8.9 main panel

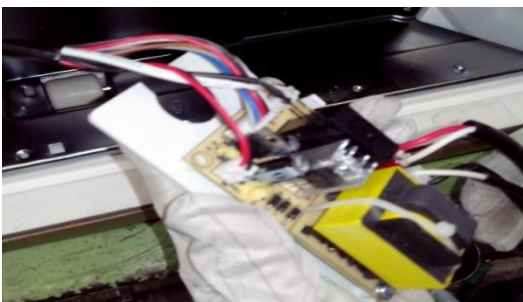
<p>1. Take down screws</p>	
<p>2 Take out main control panel cover</p>	

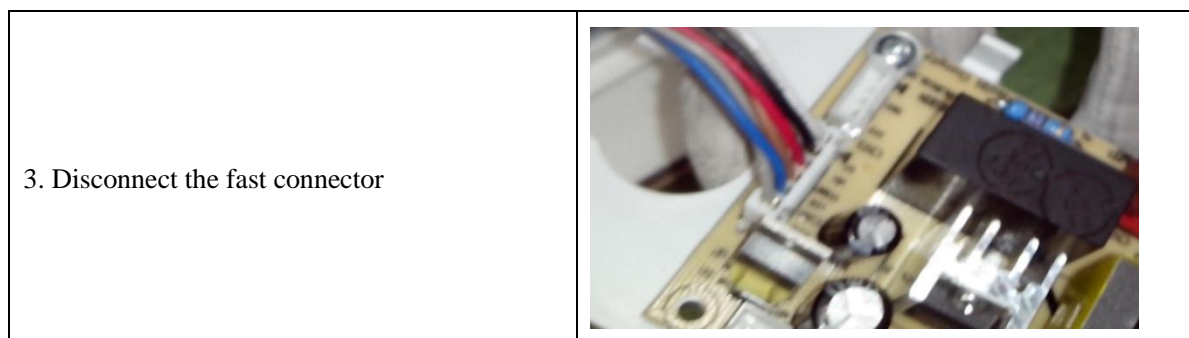

### 8.9 Bar counter(None)

Disassembly and installation of bar counter	None
Disassembly and installation bar doorseal	None

### 8.10 Water dispenser(None)

Disassembly and installation of water valve	None
Disassembly and installation of water tank	None

### 8.11Ice maker(None)

Disassembly and installation of ice maker	None
Disassembly and installation of water system	None
Disassembly and installation ice machine sensor	None

## 9. Function and operation

### 9.1 operation panel

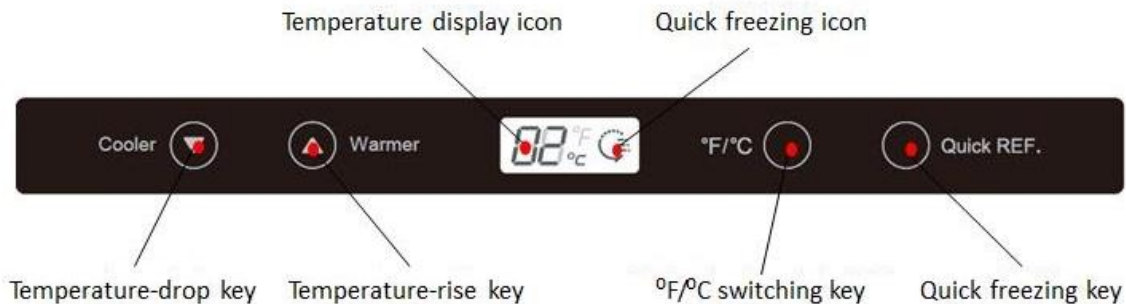

Powering on each time, the display screen gives a full display for 3s; then the panel displays normal.

Normal display Display area lighten all the time: If the system has an error, the area display relevant error code (circularly). Otherwise, refrigerating temperature is on.

Display control(Normal running mode and test mode)1.Power for the first time, shown as Celsius temperature, the temperature is 5 °C

2. Display area always show the setting temperature, the display will continue light on

### 9.2 Temperature control

#### ➤ Temperature setting

- Press the Temperature-rise key , the temperature will increase 1 °C ( or 1 °F). After 5s, the cooler will operate according to the setting temperature;

- Press the Temperature-drop key , the temperature will decrease 1 °C ( or °F). After 5s, the cooler will operate according to the setting temperature

- 

The beverage cooler's temperature can be setted between -3~10 °C ( 27~50 °F )

#### ➤ Switching of the Fahrenheit temperature and Celsius temperature

- fahrenheit temperature switching celsius temperature: When the fahrenheit temperature is displayed, press the key, displays the celsius temperature
- celsius temperature switching fahrenheit temperature: When the celsius temperature is displayed, press the key, displays the fahrenheit temperature

### 9.3 Alarm(None)

### 9.4 Failure code and solutions

Error Code	Failure Type	Solution
E1	Fault of temperature sensor	Step 1: Check whether the terminal CN3 and CN5 is well stuck, pull out the terminal and re-stick it in place Step 2: Check to see if there're foreign matters on the terminal. Step 3: Inspect the temperature sensor whether contact is bad, and resend contact the fast connector Step 4: Replace main control board

E4	Fault of frost sensor	<p>Step 1: Check whether the terminal CN3 and CN5 is well stuck, pull out the terminal and re-stick it in place</p> <p>Step 2: Check to see if there're foreign matters on the terminal.</p> <p>Step 3: Inspect the defrost sensor whether contact is bad, and resend contact the fast connector</p> <p>Step 4: Replace main control board</p>
----	-----------------------	--

### 9.5 Defrost function

The defrosting of evaporator is activated when the temperature monitored by defrosting sensor is below setted point., compressor switching off, following the temperature rise, the frost on evaporator becomes water, and the water flow into the evaporating pan via the draining system, the water in evaporating pan evaporate away finally.

### 9.6 Compressor fan control (None)

### 9.7 Self-diagnosis (None)

## 10. Circuit description

### 10.1 Power Supply

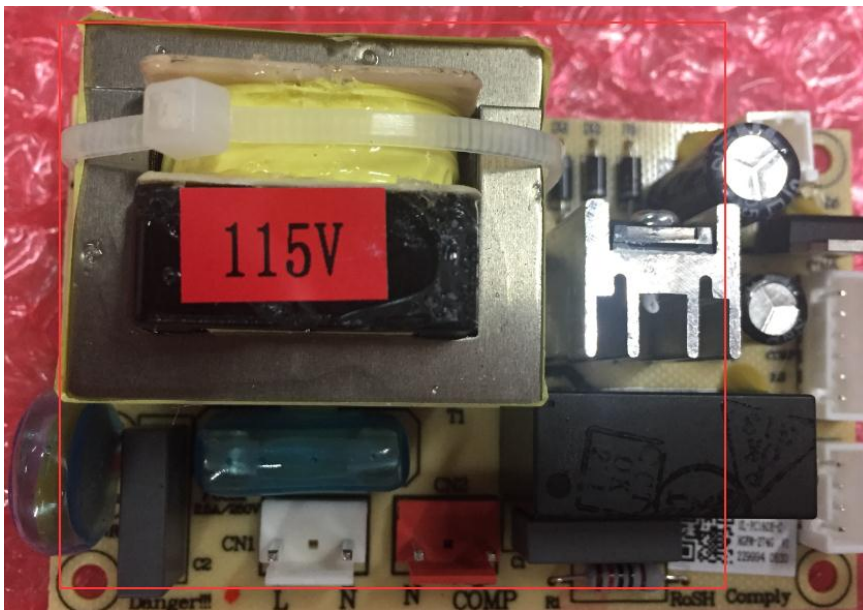
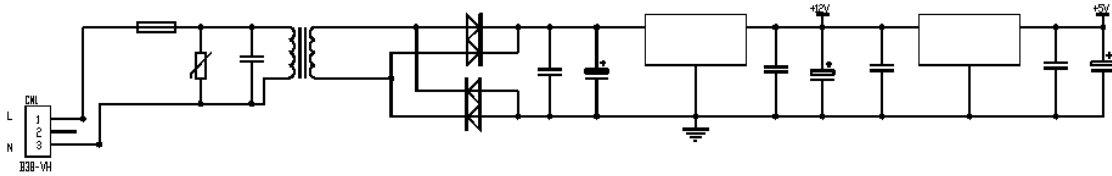

AC input voltage is lowered by linear transformer, then filtered by rectifier diode & LC into DC 12V, DV12V provide power to reply what controls the switches of compressor and defroster. DC12V is changed through adjuster 7805 in to stable DC5V,DC5V provide the power to control chip, control chip monitor the temperature changes in the refrigerator. If no power detected in test, firstly check whether there is input voltage between the L& N line of main PCB, if no input voltage(230V/115V), please check whether there is power supply in the socket; if there is input voltage, put the black probe of multi meter on the bottom of "GND" pin, and put the red probe on the bottom of "+5v" or "+12v" pins, if there is "12v" or "5v" detected, check whether there is loose connection with these wiring connectors; if there is no "12v" or "5v" detected, it means the main PCB is damaged, replace it by a new one.

10.2 Door trip test circuit(None)

10.3 Temperature test circuit

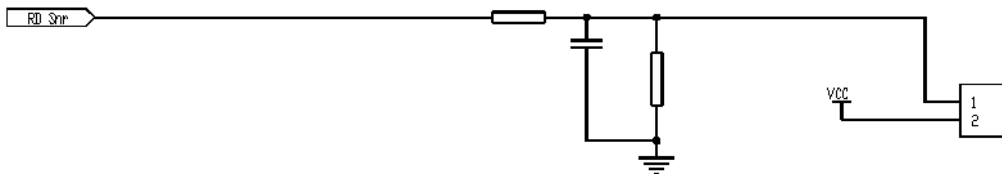

The characteristic that resistance value reduces as the temperature increases is deemed to have negative slope or negative temperature coefficient (NTC), and such thermostat is called as NTC thermostat. The resistance value changes sensitively with temperature and typically changes 7% ~ 3% per degree centigrade. Sensor used in the refrigerator is NTC thermostat.

There is following computing formula for the sensor:

$$\text{Sampling voltage} / \text{reference voltage} = R1 / (RNTC + R1)$$

$$\text{AD value} / \text{reference AD value} = R1 / (RNTC + R1)$$

The reference voltage is 5V, RNTC is the resistance value of the sensor

The sensors work rely on the resistance value changes in accordance with the temperature, by using of the thermal couple what has resistance and coefficient of middle temperature. This kind of thermal couple which resistance decrease following the temperature increase is call NTC(negative temperature coefficient), the typical change of resistance value is 7%~3% per °C, by using the character of voltage dividing of resistance, the specific voltage value is sent to main PCB.

In inspection, unplug the wiring connector of sensor( picture10.4, socket 1&2 ), adjust the multi meter to the gear of resistance detection, put the red probe and black probe on the corresponding pins to detect the resistance value of sensor, then check with resistance table (10.8) to identify whether the sensor is damaged.

10.4 Fan motor circuit of the freezing chamber (None)

10.5 Refrigerator fan motor circuit

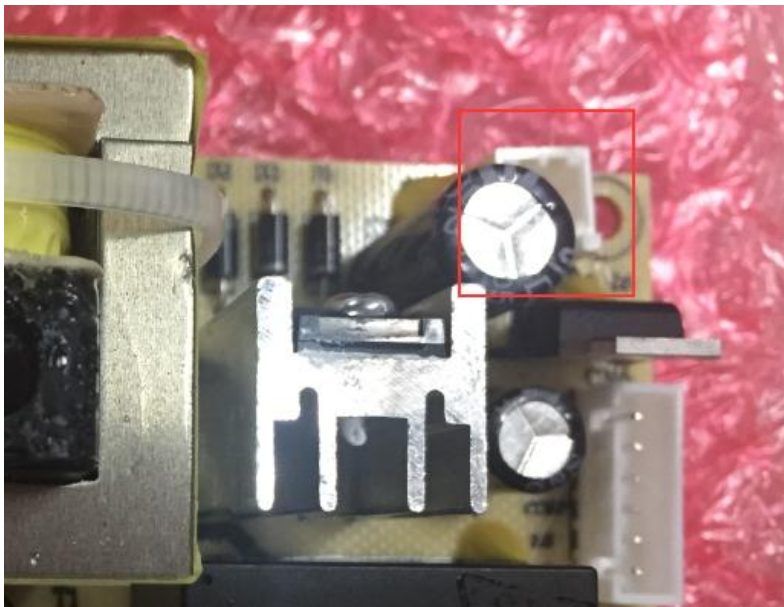
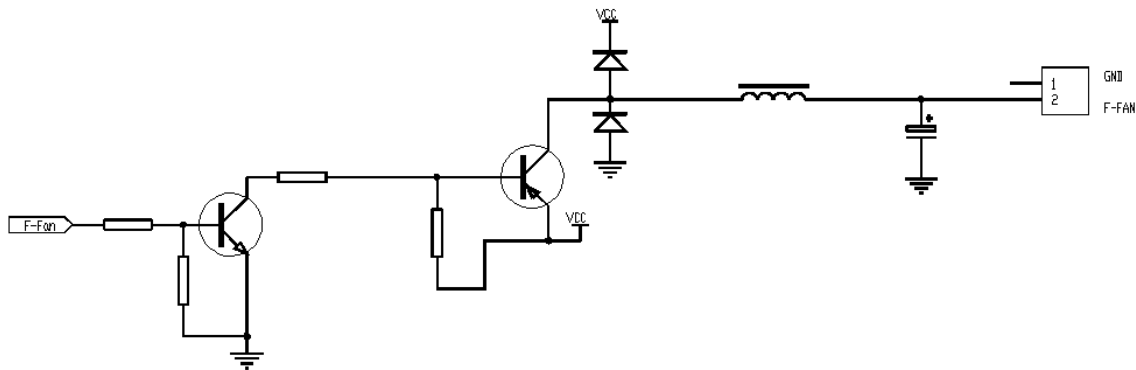

The fan motor of refrigerator runs with the compressor, at this moment check if there is 12V voltage between FAN pin and GND, in normal running, FAN is high-level input, there is 6V more voltage between FAN pins. if there is no voltage detected when the compressor is running, replace the fan motor or main PCB by new one, in test, adjust the multi meter to to gear of DC voltage, put the black probe on the pin of GND, and put the red probe on the pin of FAN, when the motor is running, there should be 6V more voltage detected; when the fan motor is in shutdown, the detected voltage should be 0V

10.6 Condensing fan motor circuit (None)

10.7 Damper motor circuit (None)

10.8 (R/T) Resistance value of the sensor (R/T)

Tx(°C)	R (KΩ)	Tx(°C)	R (KΩ)	Tx(°C)	R (KΩ)	Tx(°C)	R (KΩ)	Tx(°C)	R (KΩ)
-30	33.81	-15	14.31	0	6.495	15	3.141	30	1.617
-29	31.85	-14	13.55	1	6.175	16	2.999	31	1.55

-28	30.01	-13	12.83	2	5.873	17	2.865	32	1.486
-27	28.29	-12	12.16	3	5.587	18	2.737	33	1.426
-26	26.68	-11	11.52	4	5.315	19	2.616	34	1.368
-25	25.17	-10	10.92	5	5.06	20	2.501	35	1.312
-24	23.76	-9	10.35	6	4.818	21	2.391	36	1.259
-23	22.43	-8	9.82	7	4.589	22	2.287	37	1.209
-22	21.18	-7	9.316	8	4.372	23	2.188	38	1.161
-21	20.01	-6	8.841	9	4.167	24	2.094	39	1.115
-20	18.9	-5	8.392	10	3.972	25	2.005	40	1.071
-19	17.87	-4	7.968	11	3.788	26	1.919	41	1.029
-18	16.9	-3	7.568	12	3.613	27	1.838	42	0.9885
-17	15.98	-2	7.19	13	3.447	28	1.761	43	0.9506
-16	15.12	-1	6.833	14	3.29	29	1.687	44	0.914

## 11. Trouble shooting Method

### 11.1 No cooling

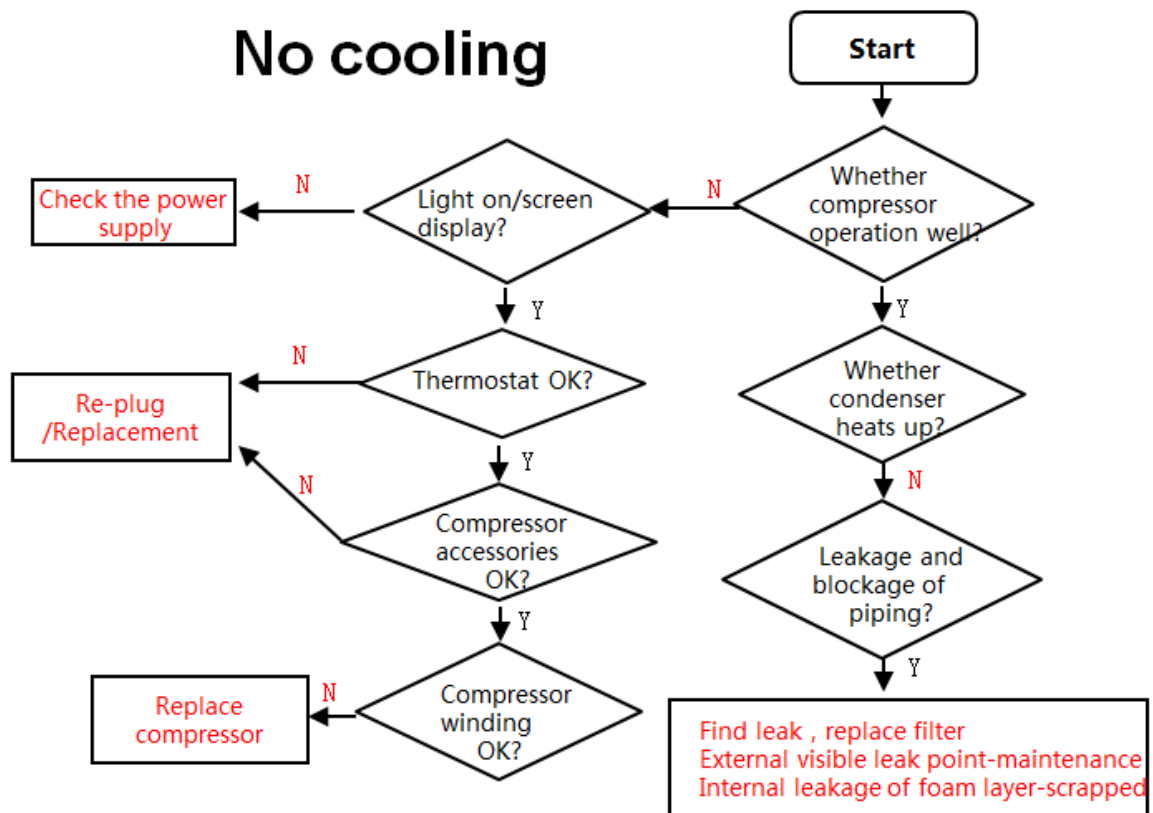

11.2 No working of compressor

# No working of compressor

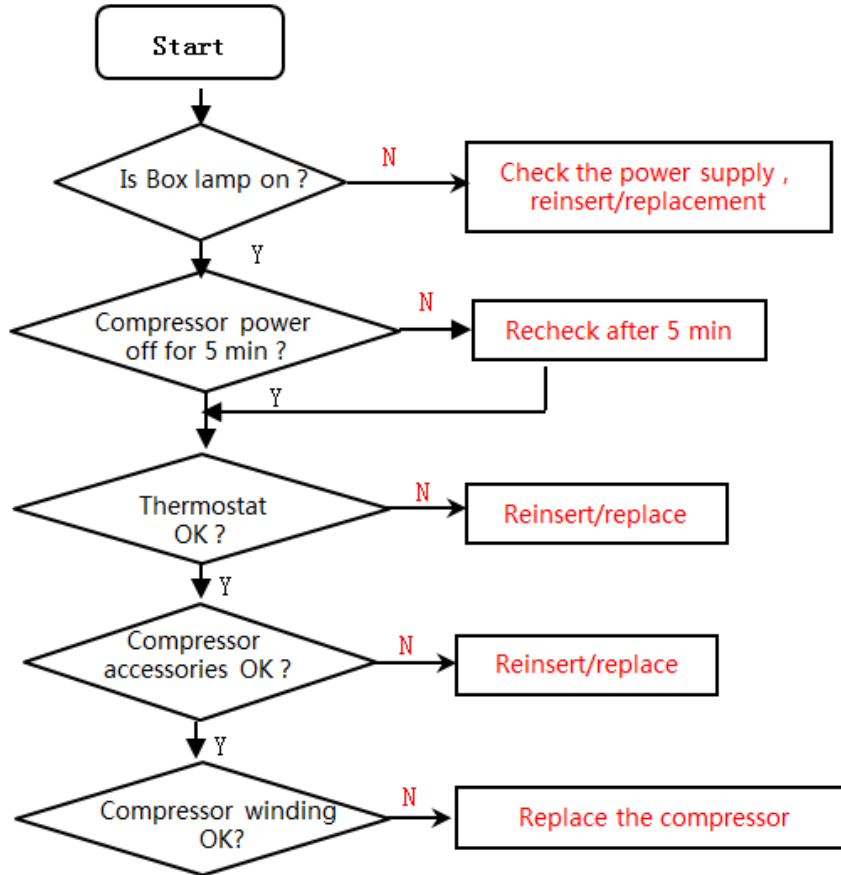

11.3 Inside frosting, no defrosting

# Inside frosting, no defrosting

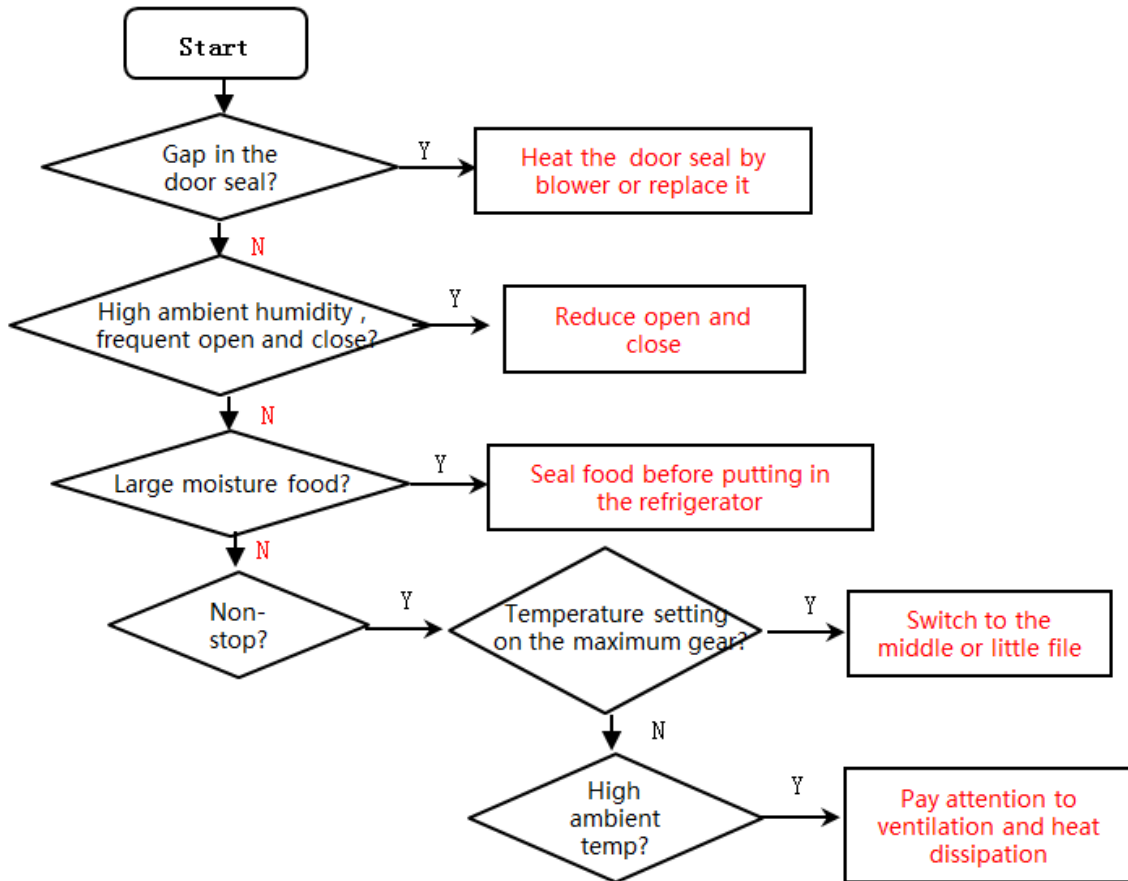

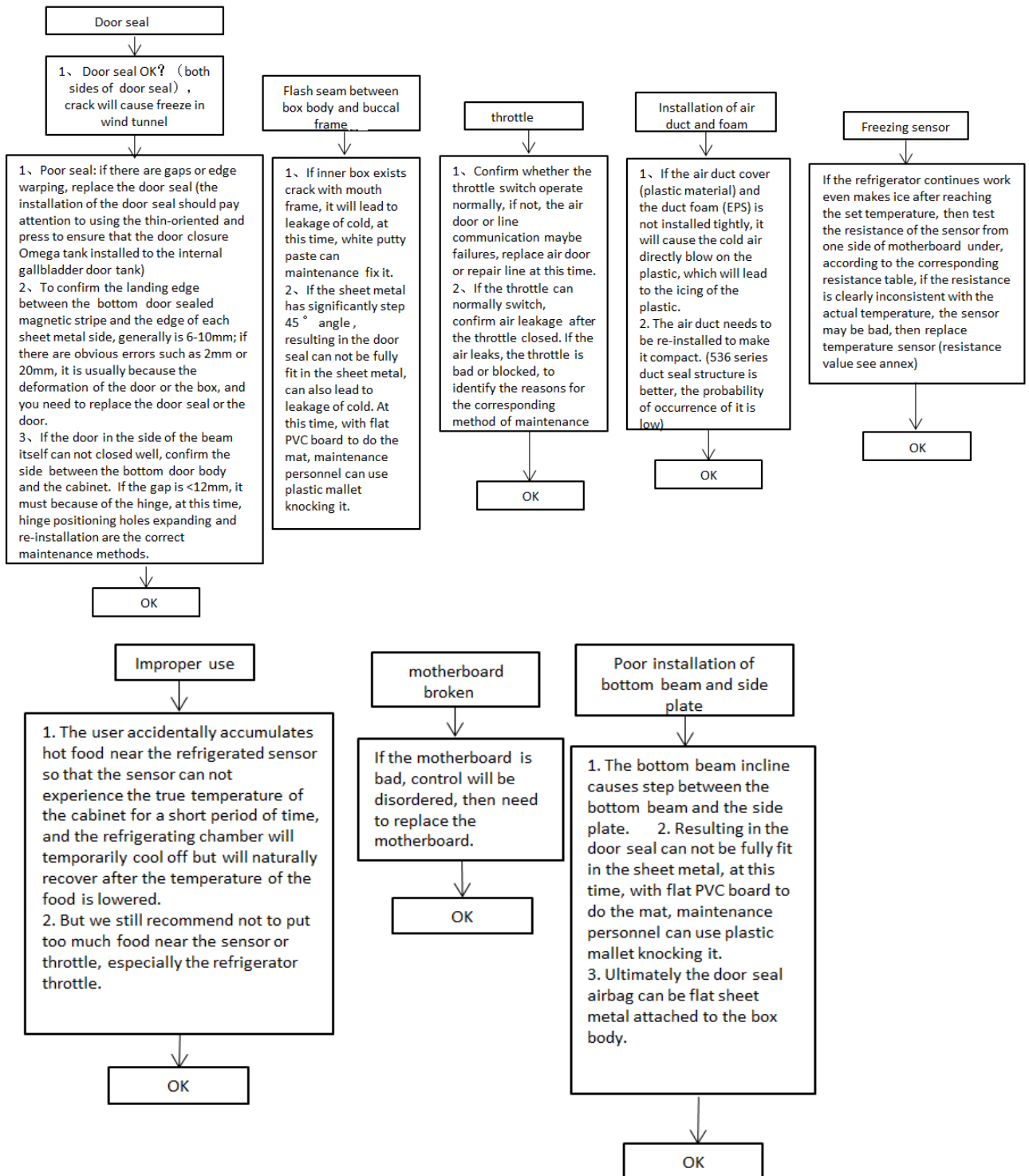

11.5 Lights inside the refrigerator don't light up (None)

11.6 Air duct not operated (None)

11.7 Fan failure (None)

11.8 Defective defrost circuit (None)

11.9 Noise

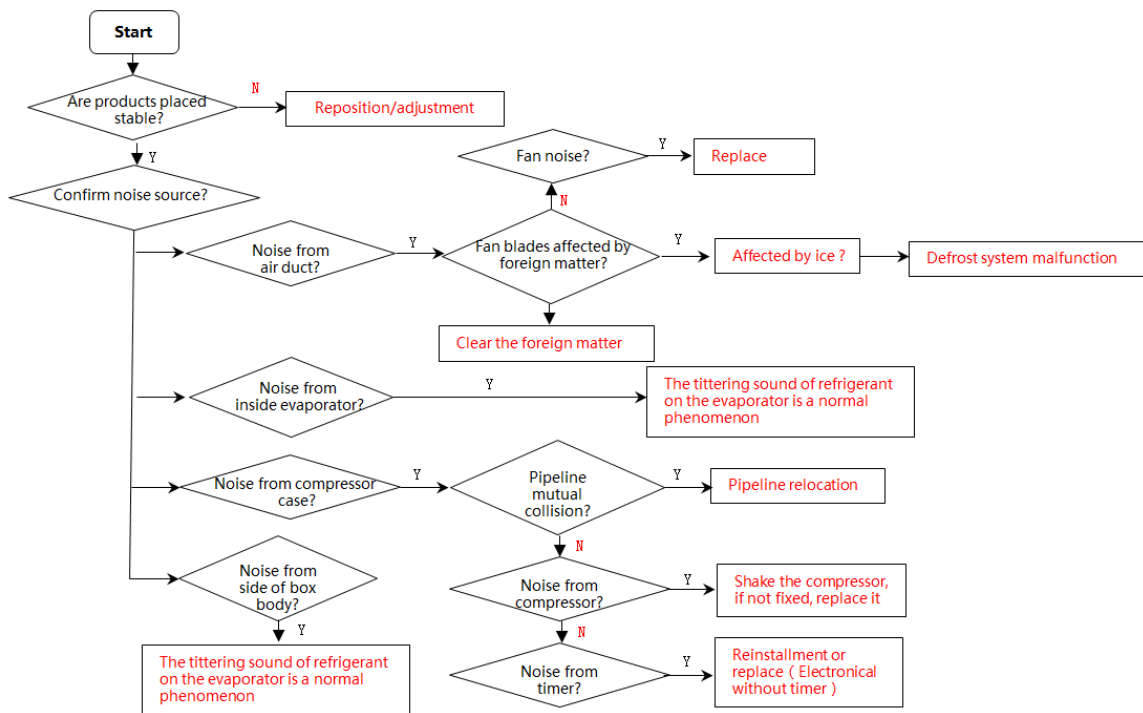

**12. Figures and details of repair parts(Documents are provided separately)**

12.1 Figures



12.2 List of parts and components



**13 Appendix:**

13.1 Electrical Schematic Diagram(None)

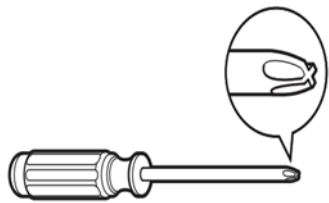
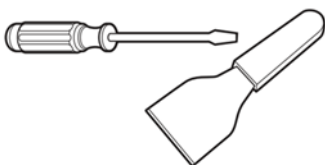
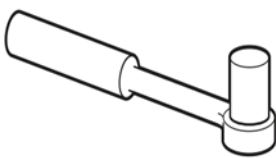
13.2 Refrigerator maintenance tooling and equipment and material



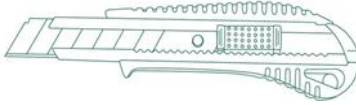



**Tooling**

No.	Name	Photo	Main Usage
1	Phillips screwdriver		screw assemble and disassemble
2	slotted screwdriver/scrapper		screw and rivet assemble and disassemble
3	Socket spanner 5/16"		hinge and compressor screw assemble and disassemble
4	Sucker		display panel and air duct cover disassemble

5	Allen wrench (2.8~4mm)		handle assemble and disassemble
6	Vise grip pliers		sealing process tube
7	Pipe cutter		pipe cutting
8	Knife		assistive tool
9	Nipper pliers		assistive tool
10	Capillary tube scissors		Shear capillary





**Equipment**

No.	Name	Photo	Main Usage
-----	------	-------	------------

1	Vacuum pump		vacuum pumping
2	Electronic scale		weighing refrigerant/gas
3	High pressure nitrogen with piezometer		pipe and cooling system(condenser, evaporator, etc) impurities clean
4	Soldering gun		heating and welding
5	Quick coupling		connection process pipeline, vacuum or charge refrigerant will be used.
6	hand leak detector		welding point leakage detect, if no, use soap-suds

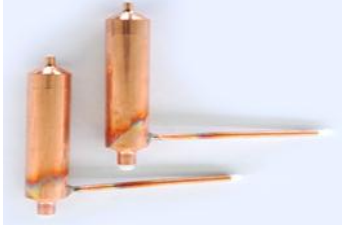
**material**

No.	Name	Photo	Main Usage
-----	------	-------	------------

1	Process pipeline		Charge the refrigerant
2	Dry filter		Involving a system failure to be replaced
3	Copper welding rod		tube welding
4	Refrigerant/gas		Add refrigerant to the system
5	Sealing tape		door fixing for reversible door option

## **Midea Refrigerators**

If you need to get detailed technical information from the manufacturer, please contact:

**xxx@midea.com**

**Refrigeration Division**

**Overseas Sales Company**

Address: No. 176, Jinxiu Avenue, Economic-Technological Development Area, Hefei, Anhui, China