



LIGHT COMMERCIAL MONO 3D AIR CONDITIONER

SERVICE MANUAL

Mono DC

Revision I: 1904, Content updated.

Table of Contents

1. Precaution
2. Part Names And Functions
3. Dimension
4. Service space
5. Refrigerant Cycle Diagram
6. Wiring Diagram
7. Static Pressure
8. Electric Characteristics
9. Sound Level
10. Accessories
11. The Specification of Power
12. Installation Details
13. Operation Characteristics
14. Electronic Function
15. Solar Panel
16. Troubleshooting
17. Disassembly Instructions

Model Numbers:

Indoor Unit:

CTBU-09HWFN1-M(C); CCA3U-09HRFN1-M(C); CFAU-09HRFN1-M(C);
CTBU-12HWFN1-M(C); CCA3U-12HRFN1-M(C); CFAU-12HRFN1-M(C);
CTBU-18HWFN1-M(C); CCA3U-18HRFN1-M(C); MUEU-18HRFN1-M(C);
CTBU-24HWFN1-M(C); MCD-24HRFN1-M(C); MUEU-24HRFN1-M(C);
CTB-36HWFN1-M(C); MCD-36HRFN1-M(C); MUE-36HRFN1-M(C);
CTB-48HWFN1-M(C); MCD-48HRFN1-M(D); MUE-48HRFN1-M(C); MUE-60HRFN1-MW;
MTIU-09HWFN1-M, MTIU-12HWFN1-M; MTIU-18HWFN1-M; MTIU-24HWFN1-M;
MTI-36HWFN1-M; MTI-48HWFN1-M; MHG-60HWFN1-MW;

Outdoor Unit:

MOB30-09HFN1-MX0W; MOB01-09HFN1-MW0W; MOB30-12HFN1-MV0W;
MOB01-12HFN1-MV0W; MOCA30-18HFN1-MT0W; MOCA01-18HFN1-MT0W;
MOD30-24HFN1-MT0W; MOD01-23HFN1-MT0W; MOBA30-09HFN1-MT0W;
MOB30-12HFN1-MT0W; MOCA31-18HFN1-MT0W; MOD31-24HFN1-MT0W;
MOD30U-36HFN1-M; MOE30U-48HFN1-M; MOE30U-60HFN1-M



WARNING

- Installation MUST conform with local building codes or, in the absence of local codes, with the National Electrical Code NFPA70/ANSI C1-1993 or current edition and Canadian Electrical Code Part1 CSA C.22.1.
- The information contained in the manual is intended for use by a qualified service technician familiar with safety procedures and equipped with the proper tools and test instruments
- Installation or repairs made by unqualified persons can result in hazards to you and others.
- Failure to carefully read and follow all instructions in this manual can result in equipment malfunction, property damage, personal injury and/or death.
- **This service is only for service engineer to use.**



CONTENTS

1. Precaution	1
1.1 Safety Precaution	1
1.2 Warning	1
2. Part Names and Features	4
2.1 Model Names of Indoor/Outdoor units	4
2.2 Part names of Indoor/Outdoor units	5
2.3 Features.....	11
3. Dimension	24
3.1 Indoor Unit	24
3.2 Outdoor Unit	31
4. Service Space	34
4.1 Indoor Unit	34
4.2 Outdoor Unit	36
5. Refrigerant Cycle Diagram	37
6. Wiring Diagram	39
6.1 Indoor Unit	39
6.2 Outdoor Unit	72
7. Fan Curves	81
8 Electric Characteristics	95
9 Sound Level	96
9.1 Indoor unit.....	96
9.2 Outdoor unit.....	99
10 Accessories	100
11. The Specification of Power	102
13.Installation Details	105
13.1Location selection.....	105
13.2 Indoor unit installation	105
13.3 Outdoor unit installation.....	115
13.4 Refrigerant pipe installation.....	116
13.5 Drainage pipe installation	120
13.6 Vacuum Drying and Leakage Checking	123
13.7 Additional refrigerant charge	124
13.8 Engineering of insulation	125
13.9 Engineering of electrical wiring	126
13.10 Test operation	126
14. Operation Characteristics	128
15. Electronic Function	129
15.1 Abbreviation.....	129

15.2 Display function	129
15.3 Main Protection.....	129
15.4 Operation Modes and Functions	131
16. Troubleshooting.....	137
16.1 Indoor Unit Error Display	138
16.2 Error Display on Two Way Communication Wired Controller	139
16.3 Outdoor unit error display.....	140
16.4 Diagnosis and Solution.....	144
16.5 Main parts check	173
17. Disassembly Instructions	183
17.1 Indoor unit.....	183
17.2 Outdoor unit.....	205

1. Precaution

1.1 Safety Precaution

- To prevent injury to the user or other people and property damage, the following instructions must be followed.

- Incorrect operation due to ignoring instruction will cause harm or damage.

- Before service the unit, be sure to read this service manual at first.

1.2 Warning

➤ Installation

- Do not use a defective or underrated circuit breaker. Use this appliance on a dedicated circuit.

There is risk of fire or electric shock.

- For electrical work, contact the dealer, seller, a qualified electrician, or an authorized service center.

Do not disassemble or repair the product, there is risk of fire or electric shock.

- Always ground the product.

There is risk of fire or electric shock.

- Install the panel and the cover of control box securely.

There is risk of fire or electric shock.

- Always install a dedicated circuit and breaker.

Improper wiring or installation may cause electric shock.

- Use the correctly rated breaker of fuse.

There is risk of fire or electric shock.

- Do not modify or extend the power cable.

There is risk of fire or electric shock.

- Do not install, remove, or reinstall the unit by yourself (customer).

There is risk of fire, electric shock, explosion, or injury.

- Be caution when unpacking and installing the product.

Sharp edges could cause injury, be especially careful of the case edges and the fins on the condenser and evaporator.

- For installation, always contact the dealer or an authorized service center.

- Do not install the product on a defective installation stand.

- Be sure the installation area does not deteriorate with age.

If the base collapses, the air conditioner could fall with it, causing property damage, product failure, and personal injury.

- Do not let the air conditioner run for a long time when the humidity is very high and a door or a window is left open.

- Take care to ensure that power cable could not be pulled out or damaged during operation.

There is risk of fire or electric shock.

- Do not place anything on the power cable.

There is risk of fire or electric shock.

- Do not plug or unplug the power supply plug during operation.

There is risk of fire or electric shock.

- Do not touch (operation) the product with wet hands.

- Do not place a heater or other appliance near the power cable.

There is risk of fire and electric shock.

- Do not allow water to run into electrical parts.

It may cause fire, failure of the product, or electric shock.

- Do not store or use flammable gas or combustible near the product.

There is risk of fire or failure of product.

- Do not use the product in a tightly closed space for a long time.

Oxygen deficiency could occur.

- When flammable gas leaks, turn off the gas and open a window for ventilation before turn the product on.

- **If strange sounds or smoke comes from product, turn the breaker off or disconnect the power supply cable.**

There is risk of electric shock or fire.

- **Stop operation and close the window in storm or hurricane. If possible, remove the product from the window before the hurricane arrives.**

There is risk of property damage, failure of product, or electric shock.

- **Do not open the inlet grill of the product during operation. (Do not touch the electrostatic filter, if the unit is so equipped.)**

There is risk of physical injury, electric shock, or product failure.

- **When the product is soaked, contact an authorized service center.**

There is risk of fire or electric shock.

- **Be caution that water could not enter the product.**

There is risk of fire, electric shock, or product damage.

- **Ventilate the product from time to time when operating it together with a stove etc.**

There is risk of fire or electric shock.

- **Turn the main power off when cleaning or maintaining the product.**

There is risk of electric shock.

- **When the product is not be used for a long time, disconnect the power supply plug or turn off the breaker.**

There is risk of product damage or failure, or unintended operation.

- **Take care to ensure that nobody could step on or fall onto the outdoor unit.**

This could result in personal injury and product damage.

➤ CAUTION

- **Always check for gas (refrigerant) leakage after installation or repair of product.**

Low refrigerant levels may cause failure of product.

- **Install the drain hose to ensure that water is drained away properly.**

A bad connection may cause water leakage.

- **Keep level even when installing the product.**

It can avoid vibration of water leakage.

- **Do not install the product where the noise or hot air from the outdoor unit could damage the neighborhoods.**

It may cause a problem for your neighbors.

- **Use two or more people to lift and transport the product.**

- **Do not install the product where it will be exposed to sea wind (salt spray) directly.**

It may cause corrosion on the product.

Corrosion, particularly on the condenser and evaporator fins, could cause product malfunction or inefficient operation.

➤ Operational

- **Do not expose the skin directly to cool air for long time. (Do not sit in the draft).**

- **Do not use the product for special purposes, such as preserving foods, works of art etc. It is a consumer air conditioner, not a precision refrigerant system.**

There is risk of damage or loss of property.

- **Do not block the inlet or outlet of air flow.**

- **Use a soft cloth to clean. Do not use harsh detergents, solvents, etc.**

There is risk of fire, electric shock, or damage to the plastic parts of the product.

- **Do not touch the metal parts of the product when removing the air filter. They are very sharp.**

- **Do not step on or put anything on the product. (outdoor units)**

- **Always insert the filter securely. Clean the filter every two weeks or more often if necessary.**

A dirty filter reduces the efficiency of the air conditioner and could cause product malfunction or damage.

- **Do not insert hands or other objects through air inlet or outlet while the product is operated.**

- **Do not drink the water drained from the product.**

- **Use a firm stool or ladder when cleaning or maintaining the product.**

Be careful and avoid personal injury.

- **Replace the all batteries in the remote control with new ones of the same type. Do not mix old and new batteries or different types of batteries.**

There is risk of fire or explosion.

- **Do not recharge or disassemble the batteries. Do not dispose of batteries in a fire.**

They may burn or explode.

- **If the liquid from the batteries gets onto your skin or clothes, wash it well with clean water. Do not use the remote if the batteries have leaked.**

2. Part Names and Features

2.1 Model Names of Indoor/Outdoor units

Series	Capacity	Indoor units	Outdoor units
Cassette	9K	CCA3U-09HRFN1-M(C)	MOB30-09HFN1-MX0W; MOB01-09HFN1-MW0W; MOBA30-09HFN1-MT0W
A5 Duct		CTBU-09HWFN1-M(C)	
Console		CFAU-09HRFN1-M(C)	
A6 Duct		MTIU-09HWFN1-M	
Cassette	12K	CCA3U-12HRFN1-M(C)	MOB30-12HFN1-MV0W; MOB01-12HFN1-MV0W; MOB30-12HFN1-MT0W;
A5 Duct		CTBU-12HWFN1-M(C)	
Console		CFAU-12HRFN1-M(C)	
A6 Duct		MTIU-12HWFN1-M	
Cassette	18K	CCA3U-18HRFN1-M(C)	MOCA30-18HFN1-MT0W; MOCA01-18HFN1-MT0W; MOCA31-18HFN1-MT0W;
A5 Duct		CTBU-18HWFN1-M(C)	
Floor Ceiling		MUEU-18HRFN1-M(C)	
A6 Duct		MTIU-18HWFN1-M	
A6 Duct	24K	MTIU-24HWFN1-M	MOD30-24HFN1-MT0W; MOD01-23HFN1-MT0W; MOD31-24HFN1-MT0W;
Cassette		MCDU-24HRFN1-M(C)	
A5 Duct		CTBU-24HWFN1-M(C)	
Floor Ceiling		MUEU-24HRFN1-M(C)	
Cassette	36K	MCD-36HRFN1-M(C)	MOD30U-36HFN1-M;
A5 Duct		CTB-36HWFN1-M(C)	
Floor Ceiling		MUE-36HRFN1-M(C)	
A6 Duct		MTI-36HWFN1-M	
Cassette	48K	MCD-48HRFN1-M(D)	MOE30U-48HFN1-M;
A5 Duct		CTB-48HWFN1-M(C)	
Floor Ceiling		MUE-48HRFN1-M(C)	
A6 Duct		MTI-48HWFN1-M	
HESP DUCT	60K	MHG-60HWFN1-MW	MOE30U-60HFN1-M
Floor Ceiling		MUE-60HRFN1-MW	

2.2 Part names of Indoor/Outdoor units

Cassette Units

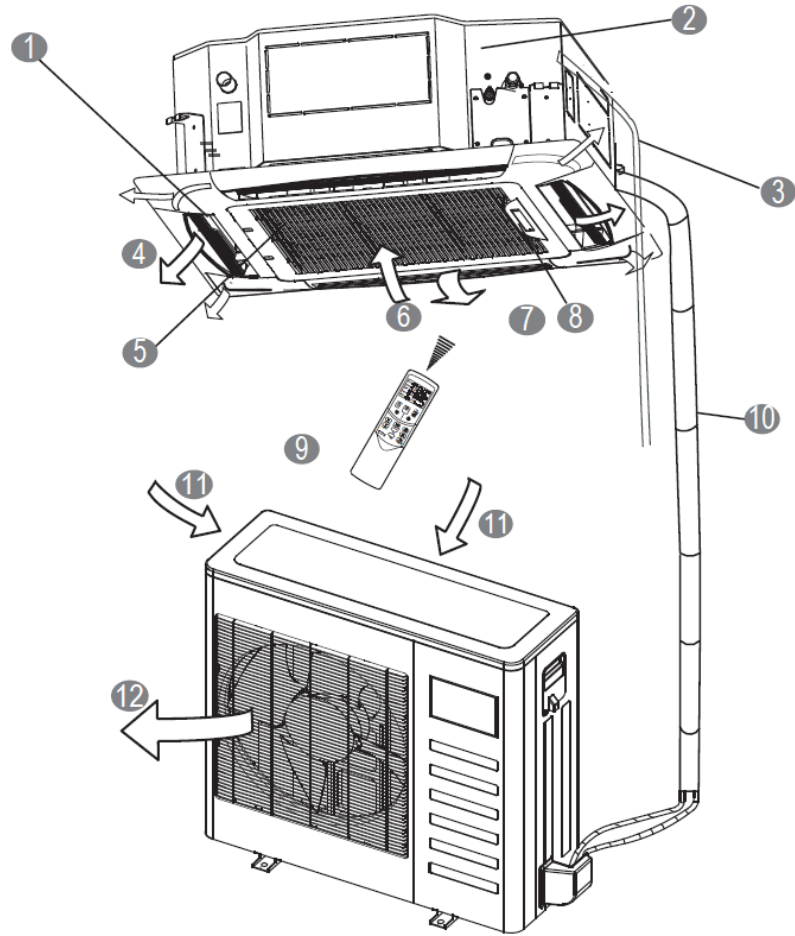

- | | | | |
|---|--|---|-------------------|
| ① | Air flow louver(at air outlet) | ⑦ | Air-in grill |
| ② | Drain pump(drain water from indoor unit) | ⑧ | Display panel |
| ③ | Drain pipe | ⑨ | Remote controller |
| ④ | Air outlet | ⑩ | Refrigerant pipe |
| ⑤ | Air filter(inside air-in grill) | ⑪ | Air inlet |
| ⑥ | Air inlet | ⑫ | Air outlet |

A5 Duct Units

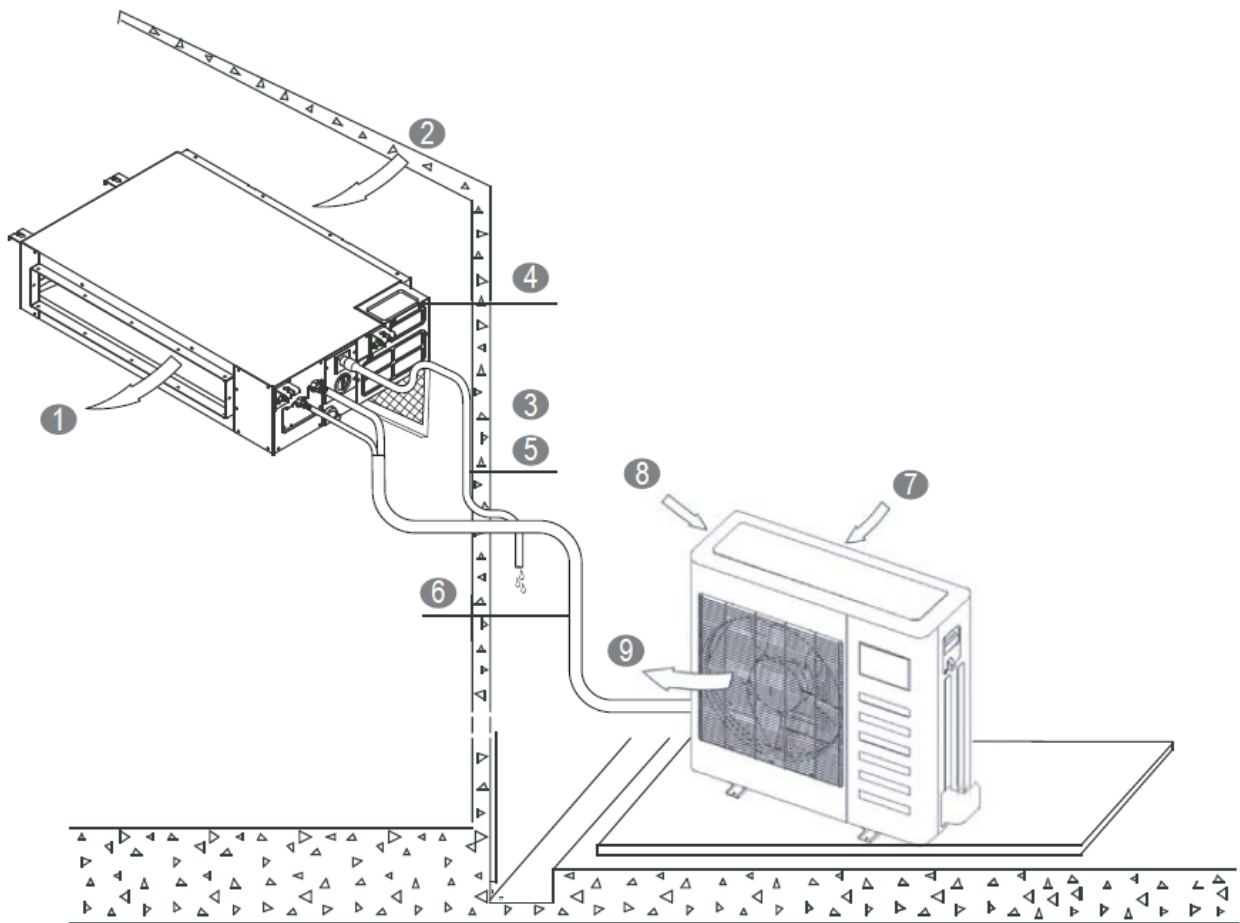

INDOOR UNIT

- ① Air outlet
- ② Air inlet
- ③ Air filter(on some models)
- ④ Electric control cabinet
- ⑤ Drain pipe

OUTDOOR UNIT

- ⑥ Connecting pipe
- ⑦ Air inlet
- ⑧ Air inlet(side and rear)
- ⑨ Air outlet

A6 Duct Units

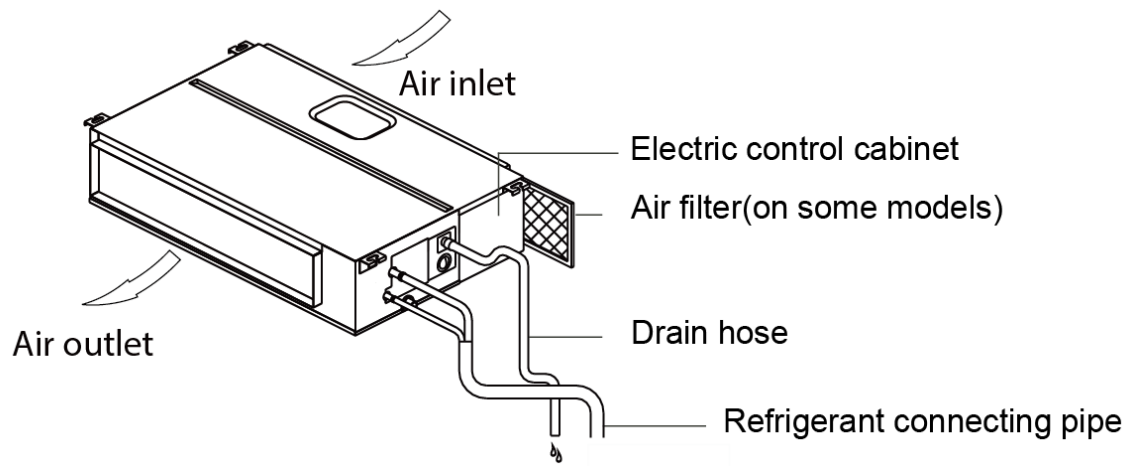

Console Units

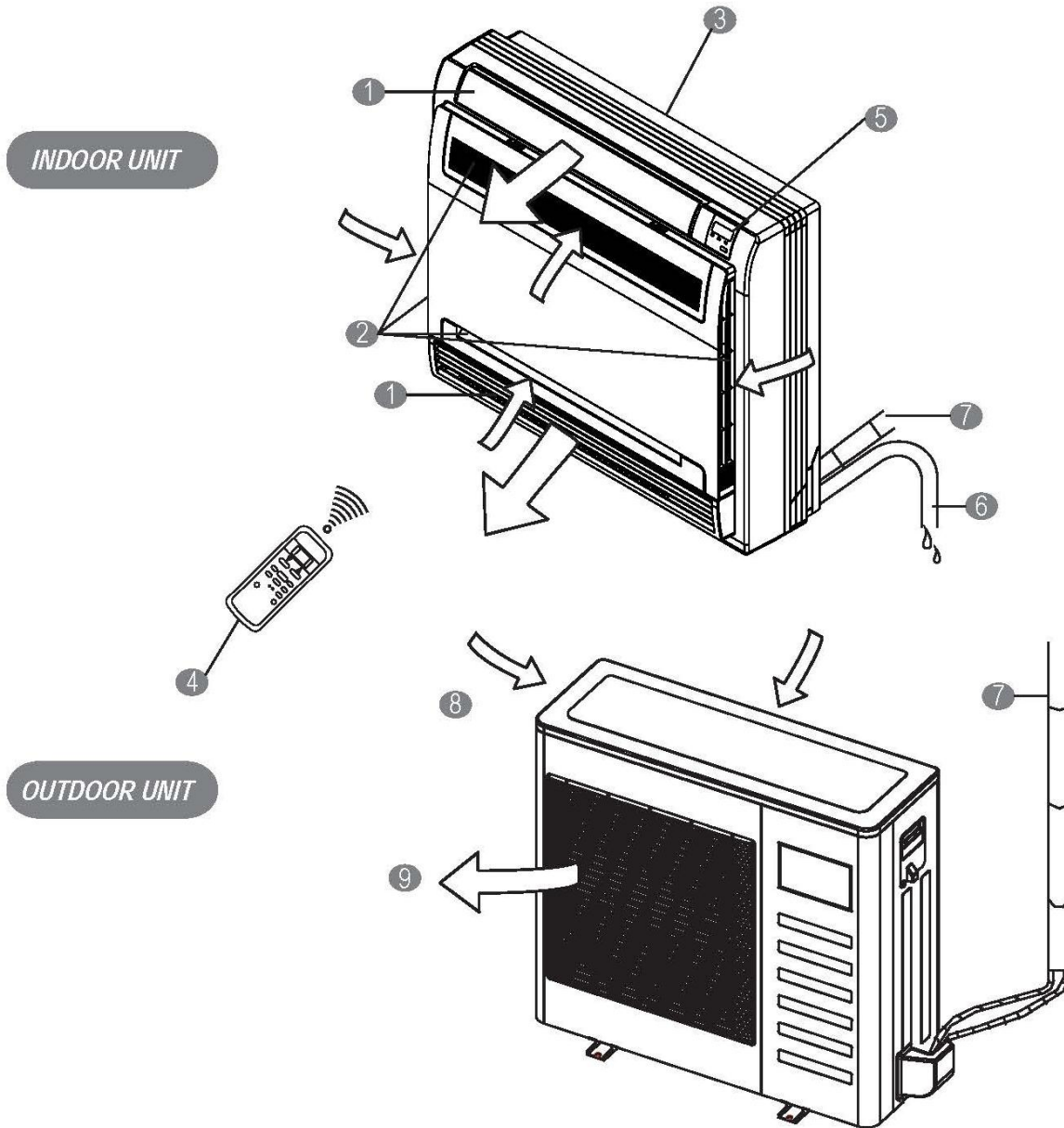

Fig.1

INDOOR UNIT

- ① Air flow louver (at air outlet)
- ② Air inlet (with air filter in it)
- ③ Installation part
- ④ Remote controller
- ⑤ Display panel
- ⑥ Drain pipe

OUTDOOR UNIT

- ⑦ Connecting pipe
- ⑧ Air inlet
- ⑨ Air outlet

Ceiling-floor Units

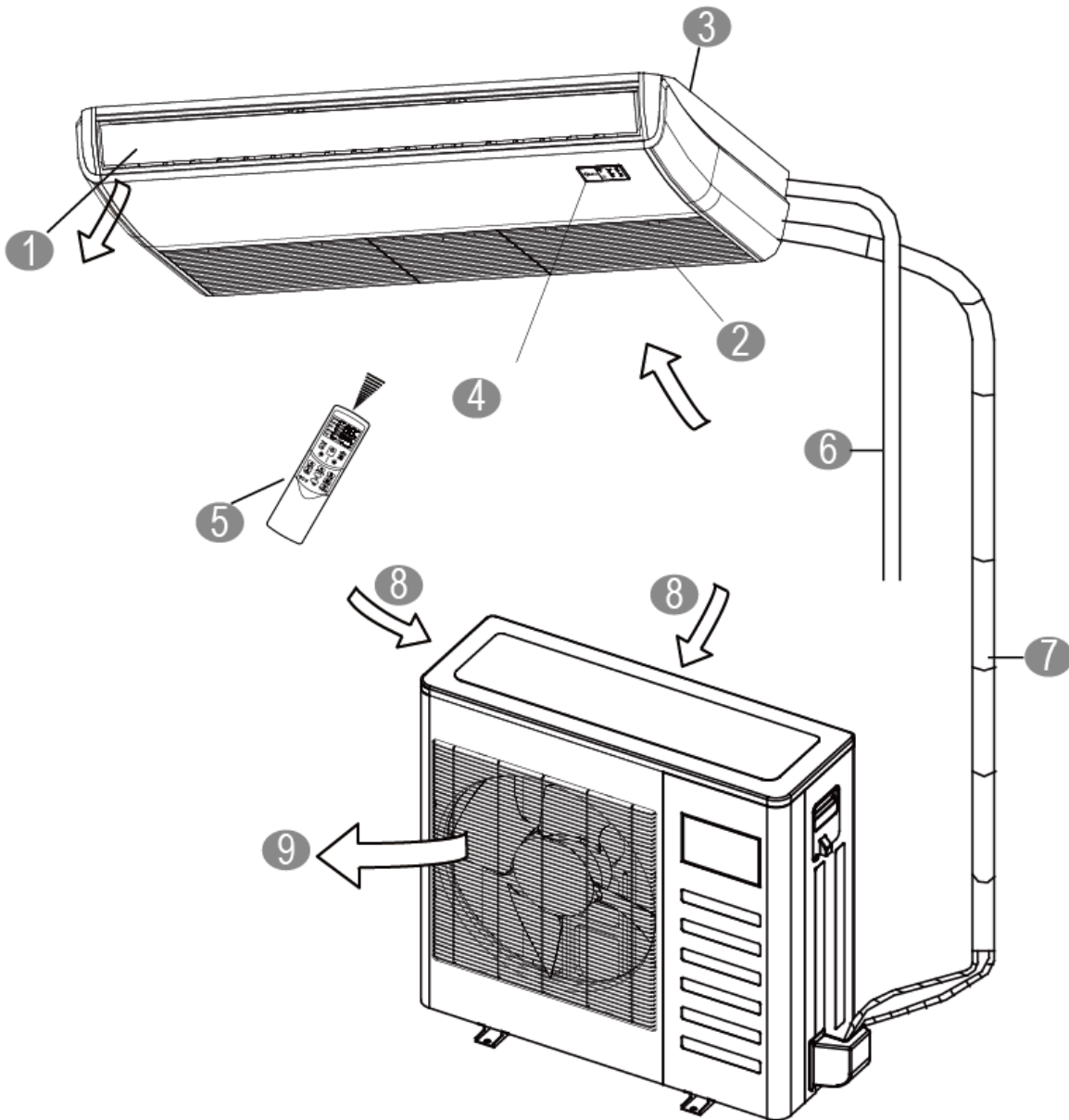

INDOOR UNIT

- ① Air flow louver (at air outlet)
- ② Air inlet (with air filter in it)
- ③ Installation part
- ④ Display panel
- ⑤ Remote controller
- ⑥ Drain pipe

OUTDOOR UNIT

- ⑦ Connecting pipe
- ⑧ Air inlet
- ⑨ Air outlet

HESP DUCT Units

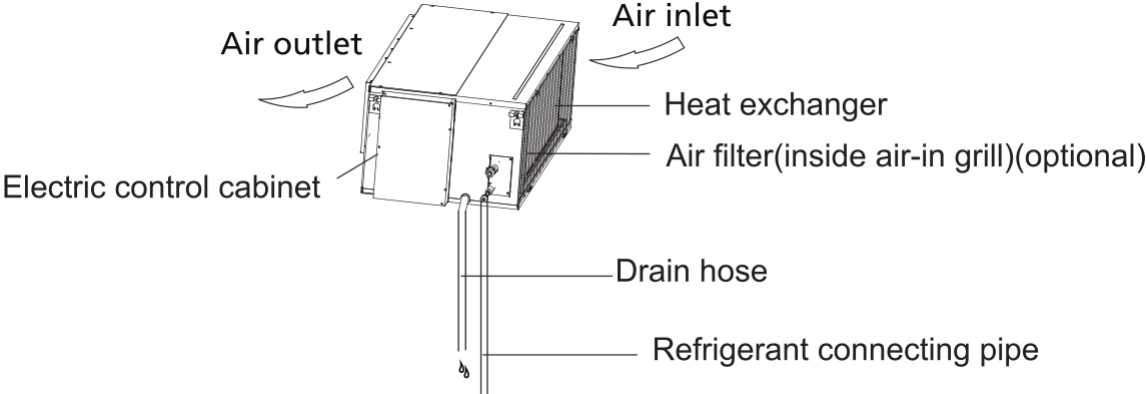

2.3 Features

2.3.1 A5 Duct Units

2.3.1.1 Easy Installation: Two air Inlet Styles (Bottom side or Rear side)

- Air inlet from rear is standard for all capacity; air inlet from bottom is optional.
- The size of air inlet frame from rear and bottom is same, it's very easy to move the cover from bottom to rear side, or from rear to the bottom, in order to matching the installation condition.

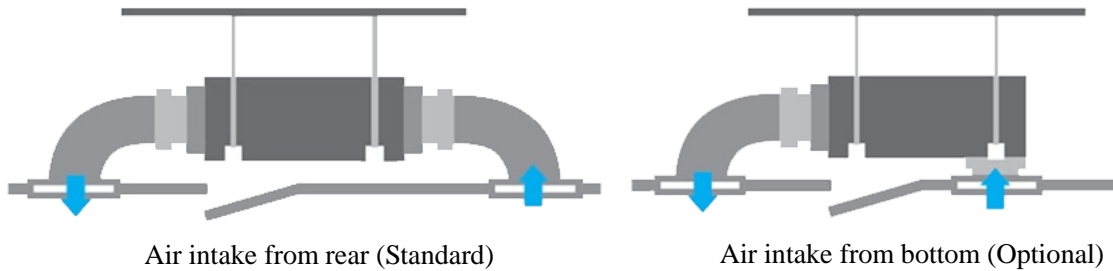

2.3.1.2 Fresh Air Intake Function

- Install one duct from the reserved fresh-air intake to outdoor.
Continually inhale the fresh air to improve the quality of the indoor air, fulfills air quality more healthy and comfortable.

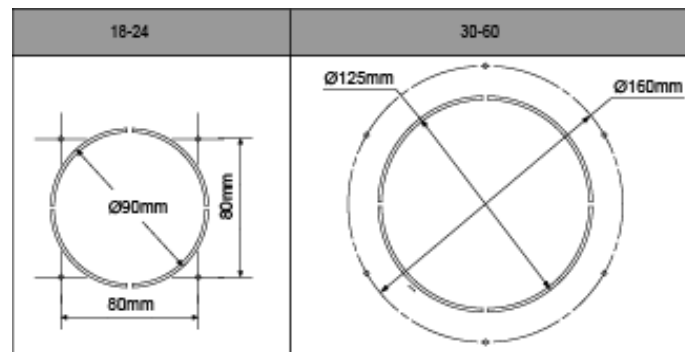

2.3.1.3 Easy Maintenance

- Clean the filter (Optional, standard product without filter)
It is easy to draw out the filter from the indoor unit for cleaning, even the filter is installed in rear side or bottom side.

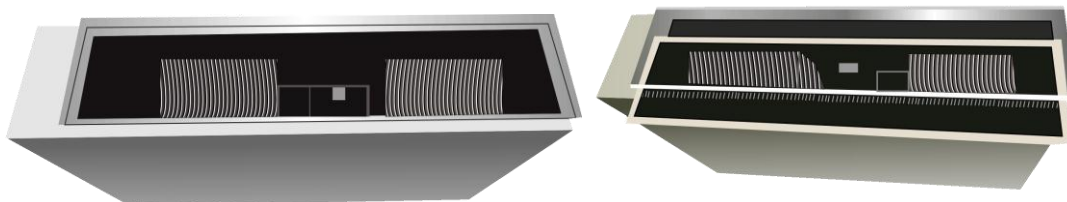

- Replace the motor or centrifugal fan
Remove the ventilated panel firstly. Remove a half of blower housing and take out the motor with centrifugal fan. Directly remove two bolts, and then replace the motor or centrifugal fan easily.

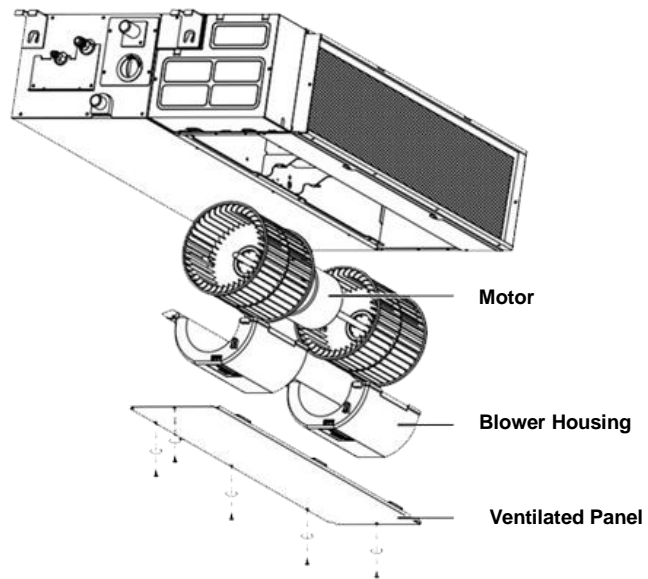

2.3.1.4 Reserved Remote On-off and Central Control Ports

- Reserved remote on-off ports and central control ports, can connect the cable of an on-off controller or a central controller to realize remote on-off control function or group control function.

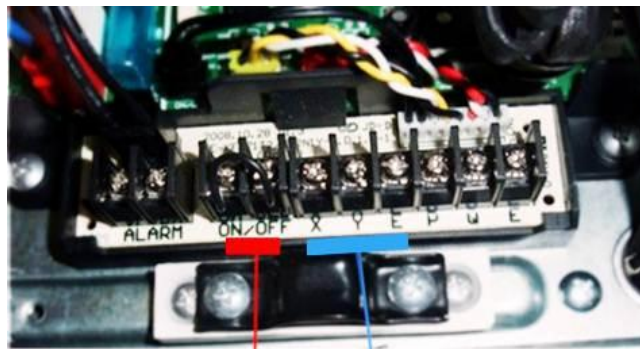

Remote on-off ports

Central control ports

2.3.1.5 Built-in Drain Pump (Optional):

- Built-in drain pump can lift the water to 750mm upmost. It's convenient to install drainage piping under most space condition.

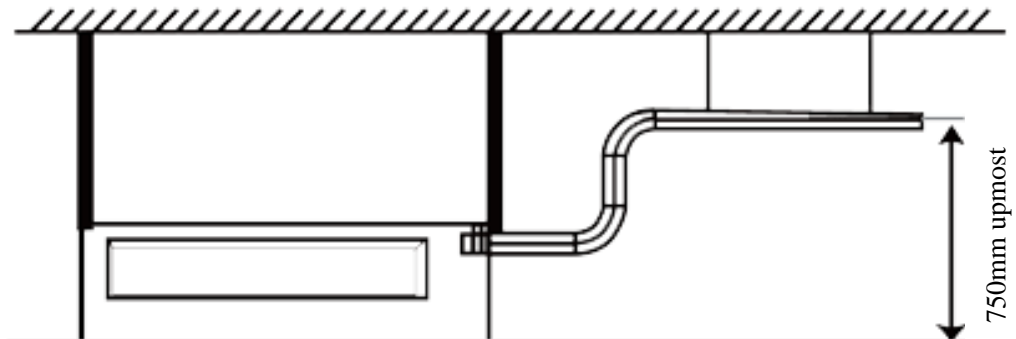

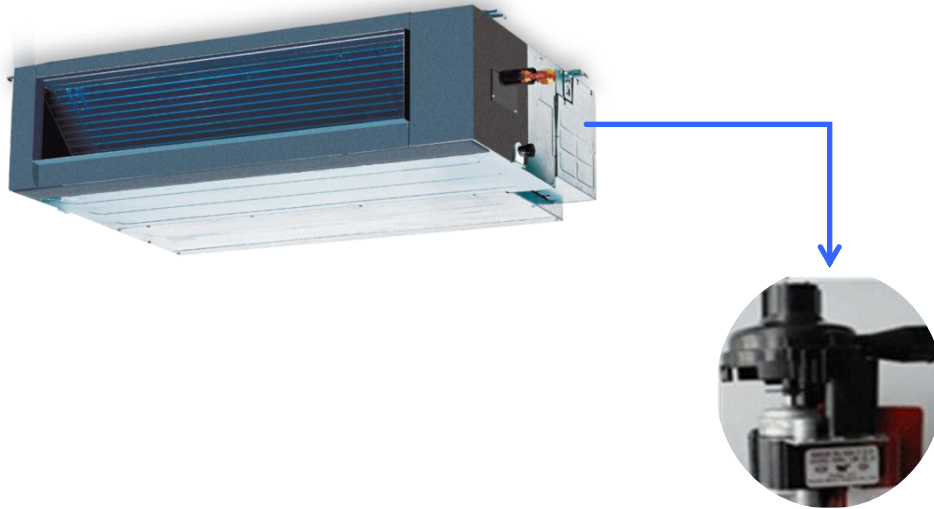

2.3.1.6 Built-in Display Board

- The standard indoor unit can be controlled by wired controller.
- There is a display board with a receiver in the E-box. Move out the display, and fix it in other place, even in the distance of 2m. The unit will realized remoter control.
- The wired controller and the display board can display the error code or production code when the chips detect some failure.

Wired Controller (Standard)

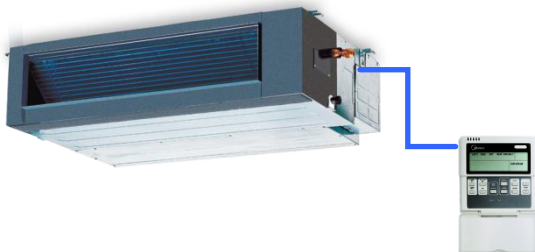

Remote Controller (Optional)

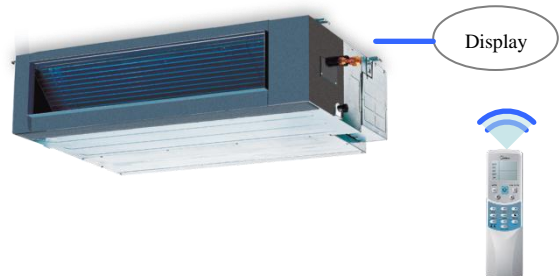

2.3.2 Cassette Units

2.3.2.1 Lower Noise

- Optimize air channel system design to ensure the maximum quietness and comfort.
- Noise max down 6dB.

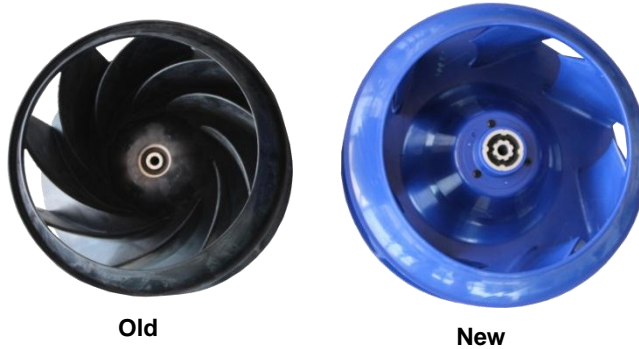

2.3.2.2 Turbo Mode (Optional)

- Turbo function can boost cooling or heating speed in a short period, and makes the room cool down or heat up rapidly.

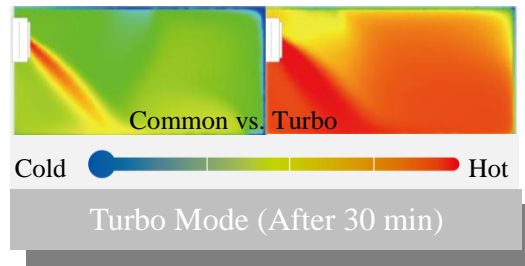

2.3.2.3 Fire-proof Controller Box

- Electrical control box adopts new design, which can meet higher fire safety requirements.

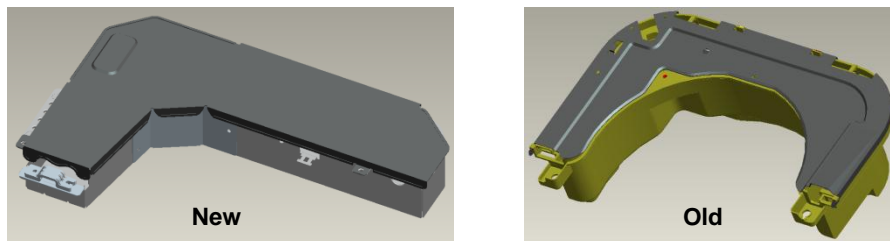

2.3.2.4 Fresh Air

- Fresh air intake function bring you fresh and comfortable air feeling.

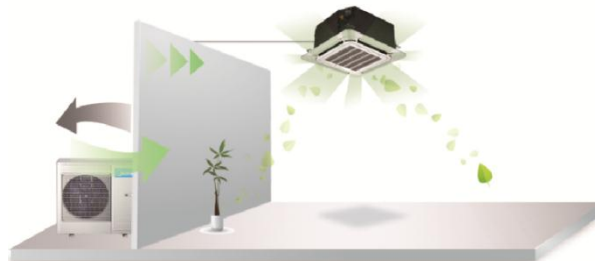

2.3.2.5 Wired Controller (Optional)

- Compared with infrared remote controller, wired controller can be fixed on the wall and avoid mislaying. It's mainly used for commercial zone and makes air conditioner control more convenient.



2.3.2.6 Build-in Drain Pump

- The drain pump can lift the condensing water up to 750mm upmost.
- It's convenient to install drainage piping under most space condition.

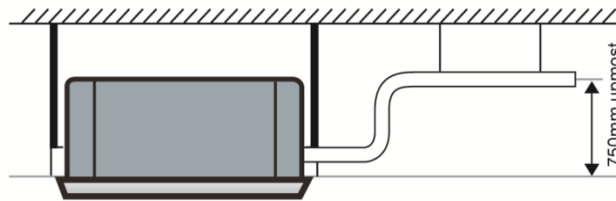

2.3.2.7 Terminals For Alarm Lamp and Long-distance On-off Controller Connection Are Standard

- Reserve terminals for the connection of alarm lamp and long-distance on-off controller, more human control.

2.3.3 Console Units

2.3.3.1. Modern and Elegant Appearance

- The simple and stylish designs can nicely harmonies with your living space.



2.3.3.2. Two Air-outlet Ways

Cooling mode

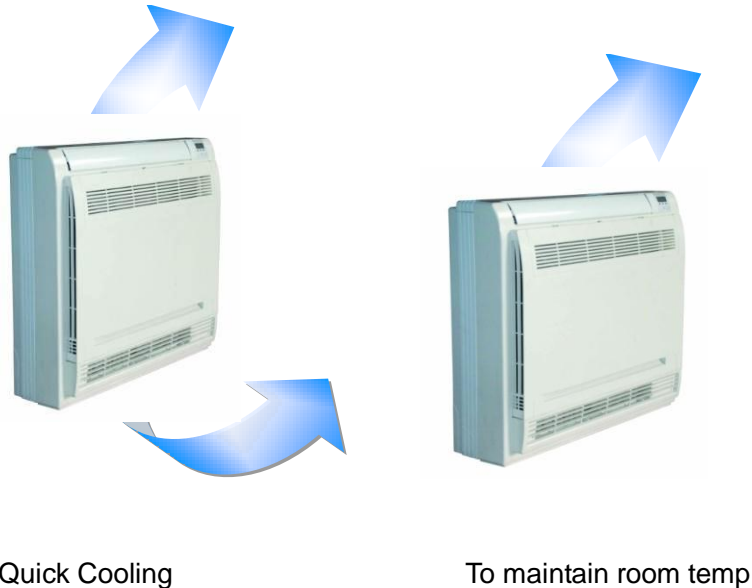

- Air outlet from top and bottom to make quick cooling -----When the A/C is just switched on, or room temp. is still high, cold air will be blown out from top and bottom air outlet to cool down the room quickly
- Air outlet from top to maintain room temp. ----When the room has been cooled down, or the A/C has been opened over 1 hour, cold air only from the top outlet to keep constant room temp

Heating mode

- Anti-cold air -----When the AC is just turn on, temperature of evaporator is very low, in this case, in order to prevent cold air direct blowing, only the upper louver is opened in a high position, the lower louver closed.



2.3.3.3. Four Air Inlets



2.3.3.4. Low Noise

- DC indoor fan motor, which has five speeds.
- Low noise and energy saving.

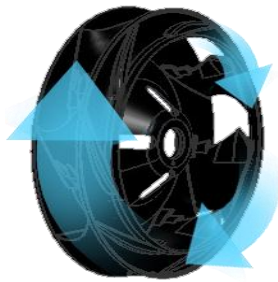

- Advanced centrifugal fan technology makes a fast airflow and reduces the indoor noise.

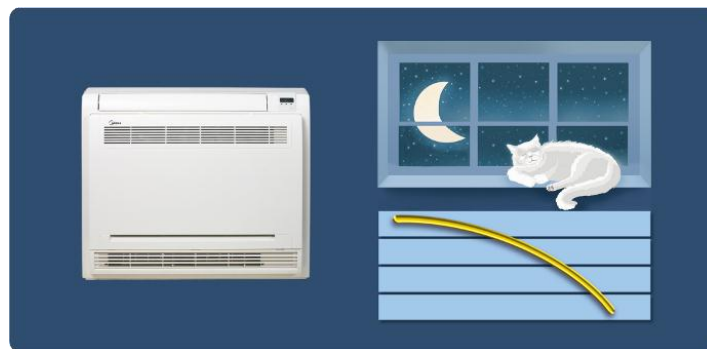

2.3.4 Ceiling-floor Units

2.3.4.1 Two-way Installation

- The rounded design of the ceiling and floor type air conditioner allows either ceiling or floor-level installation. Ceiling installation saves room space, while floor installation helps prevent the loss of warm air.

2.3.4.2 Brief Design

- Brief design that is suitable for any interior will not only give you cooling and heating performance but also upgrade your lifestyle.

2.3.4.3 3D Airflow

Vertical air flow and horizontal airflow can be adjusted by remote controller, the cooperation of the two airflow ways help to spread air comfortably throughout even a large room. With these functions, the whole room can be evenly air-conditioned for both floor-level and ceiling installation.



2.3.4.4 Optional Drainage Pipe Connection

- Both right side and left side drainage holes are available to avoid the space limitation for drainage pipe installation. Make you more convenient during installation.



2.3.4.5 Convenience Operating and Easy Maintenance

- Remote controller as standard, wired controller for optional.
- The filter without screw fixed, can be took out easily.

2.3.4.6 Easy Installation, Save Working Time

- The pipes can be connected from bottom, back and right side, makes the installation more easily.
- The wiring works can be finished before installation.

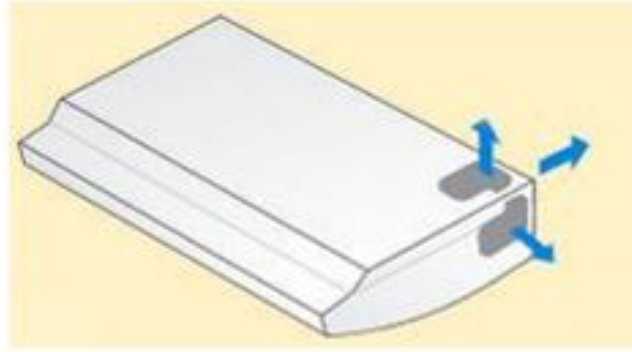

2.3.4.7 Outside Water Pump for Optional When Ceiling Installation.

2.3.5 A6 Duct Units

2.3.5.1. Higher Static Pressure

- As a ducted air conditioner with medium static pressure, it has the widest static pressure range.
- The maximum static pressure reaches 160Pa

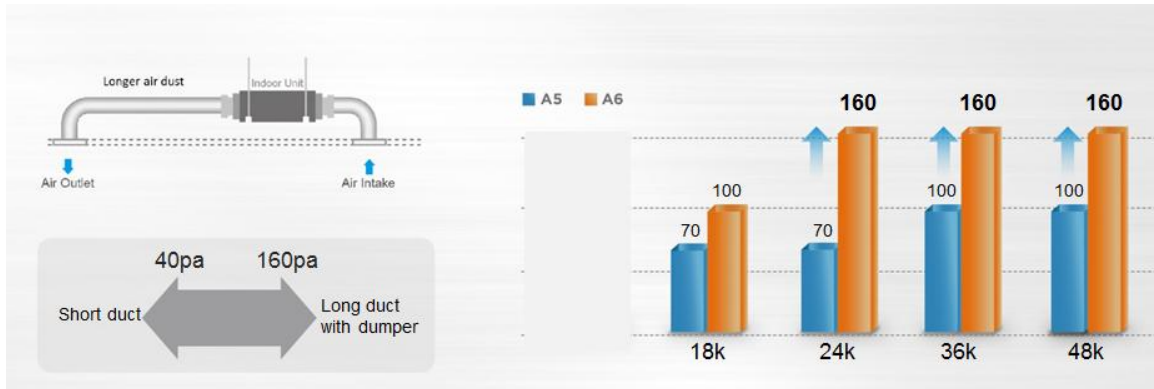

2.3.5.2. Slim Design

- The industry Lowest height is designed to be fitted into tight roof spaces.

*18K unit - 210mm, 24K/36K unit - 249mm, 48K unit - 300mm

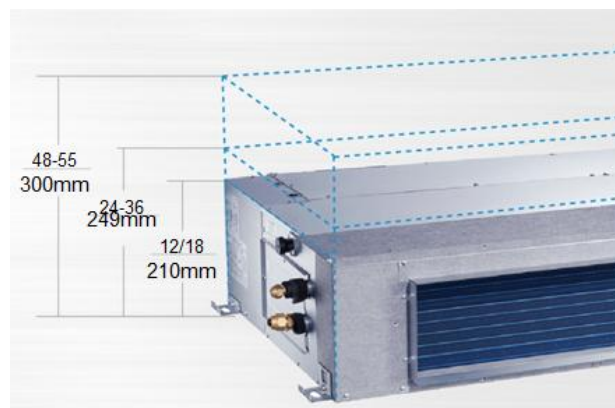

2.3.5.3. Flexible Air Intake Way (Bottom side or Rear side)

- The frame size of air inlet in rear and bottom is the same. It's very easy to switch to match different application.

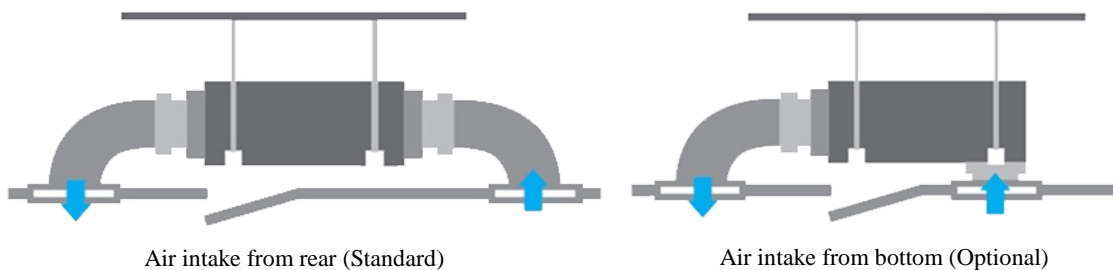

2.3.5.4. Communication wire connection

- A6 duct uses two wires without polarity connection way, which almost has no mistake during the installation.



2.3.5.5. Easy Clean

- With a larger window design, once the motor and the blower wheels have been detached, heat exchanger and water receiver tray in behind can be seen very clearly. Dust can be easily removed from the inside by vacuum



2.3.5.6. Fresh air intake function(Optional)

- Install one duct from the reserved fresh-air intake to outdoor.
Continually inhale the fresh air to improve the quality of the indoor air, fulfills air quality more healthy and comfortable.
- A ventilation motor (provided by the installer) can be installed inside the fresh air duct to improve the fresh air volume. There are reserved ports for this motor on main PCB (Standard for 3D inverter units, and only optional for DC inverter 53~160 units).

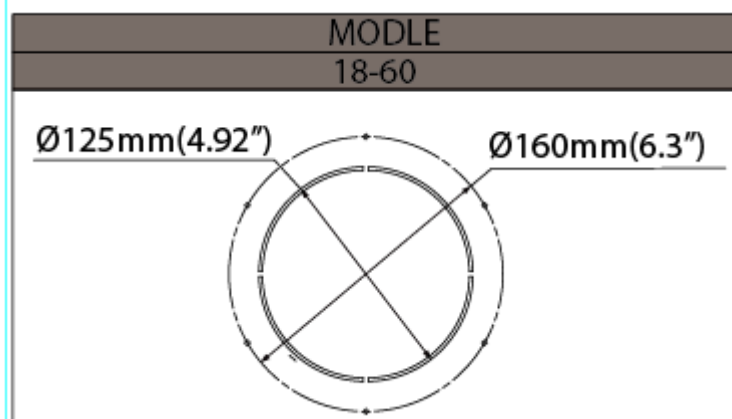

2.3.5.7. Drain pump (Optional)

- Built-in drain pump can lift the water to 750mm upmost, which widens the drainage piping range.

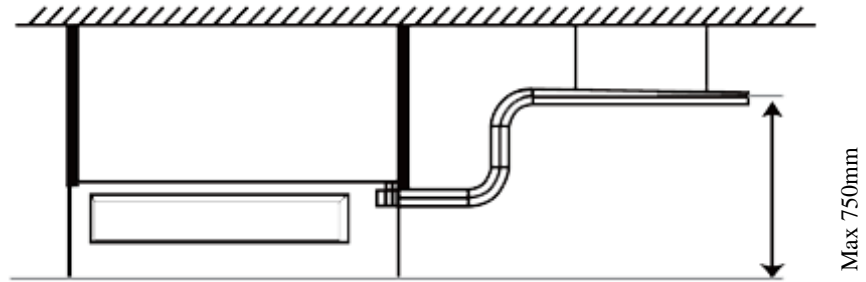

2.3.6 HESP DUCT Units

2.3.6.1 High static pressure design

- Max static pressure of indoor unit is 200Pa.
- The longest distance of air supply is 40m, the max height of air supply is 6.5m.
- Specially recommended for spacious and large rooms like large stores and factories.

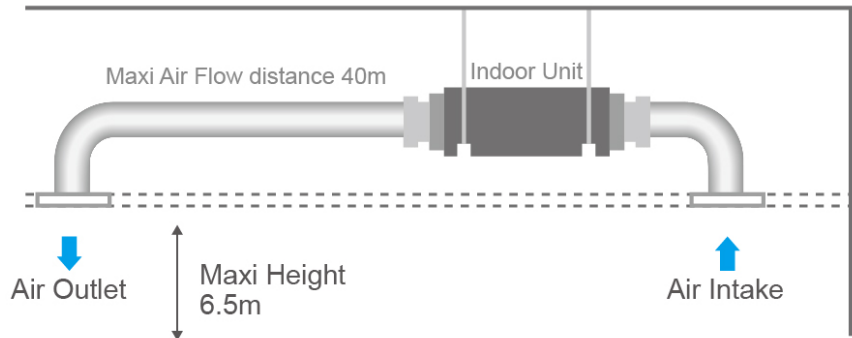

2.3.6.2 Easy maintenance

- The unit can be opened from top or bottom.

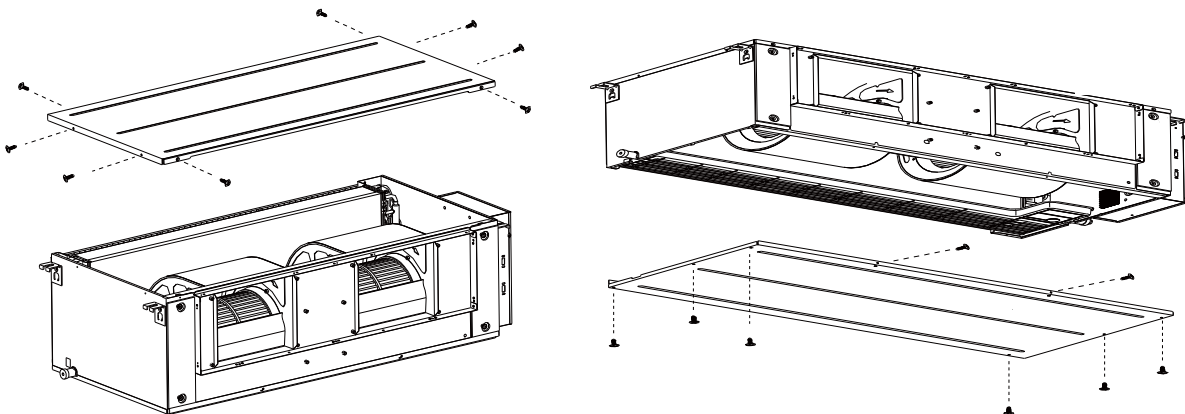

- The air outlet flange is isolated from either top panel or base panel, which makes the maintenance much easier when connecting duct.

2.3.6.3 Flexible Installation

- Different solutions for any shape room by using kinds of air distribution ducts.

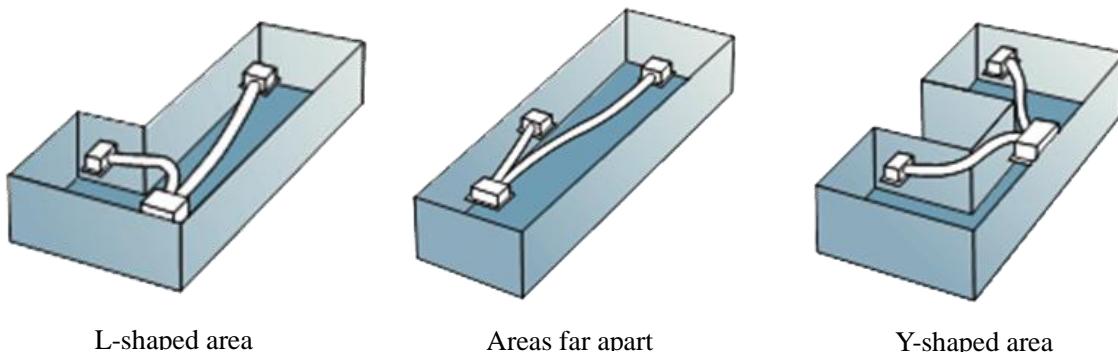

3. Dimension

3.1 Indoor Unit

A5 Duct Units

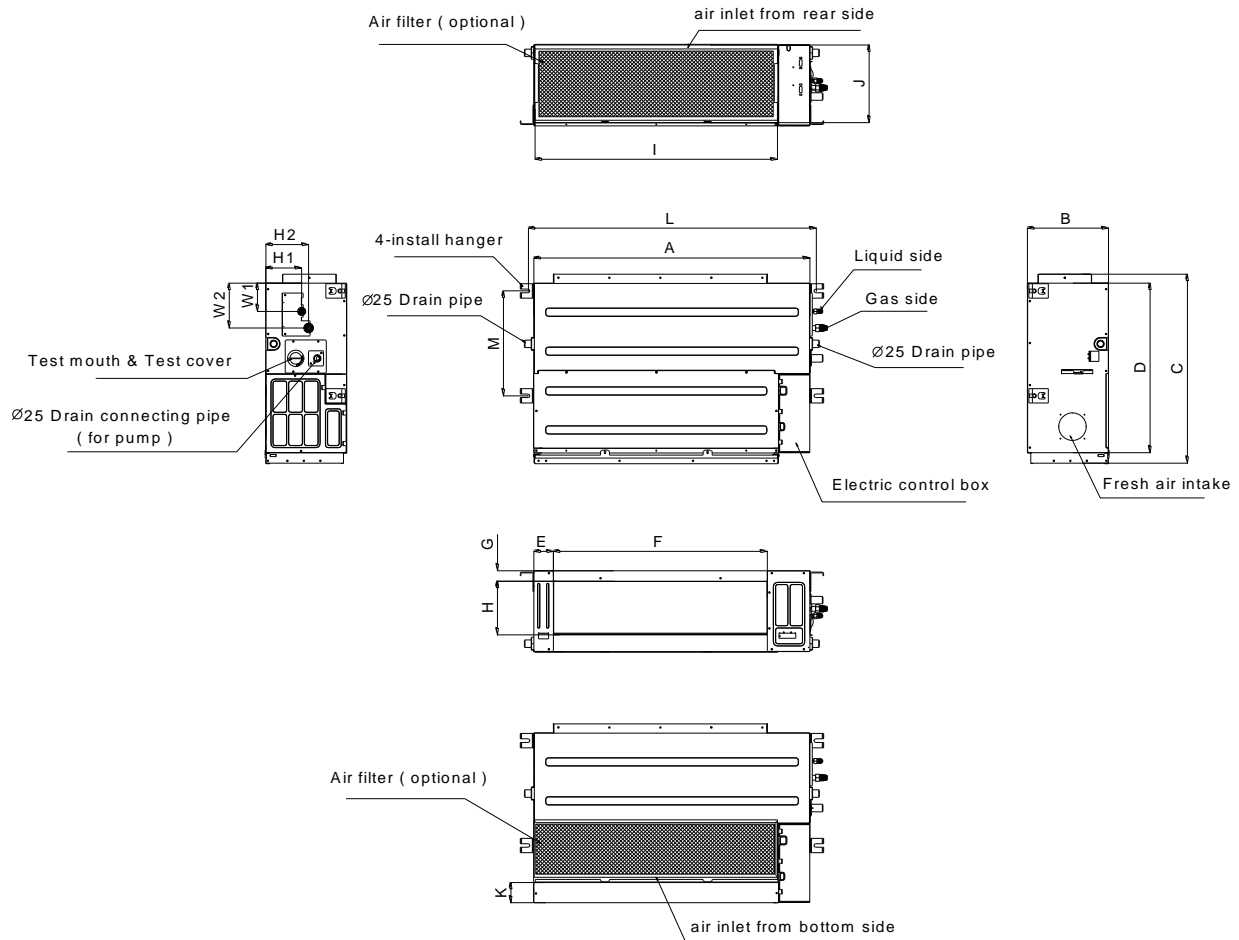

Capacity (KBtu)	Outline dimension(mm)				Air outlet opening size				Air return opening size			Size of install hanger		Size of refrigerant pipe				
	A	B	C	D	E	F	G	H	I	J	K	L	M	H1	H2	W1	W2	
9	mm	700	210	635	570	65	493	35	119	595	200	80	740	350	120	143	95	150
	in	27.56	8.27	25	22.44	2.56	19.41	1.38	4.69	23.43	7.87	3.15	29.13	13.78	4.72	5.63	3.74	5.91
12	mm	700	210	635	570	65	493	35	119	595	200	80	740	350	120	143	95	150
	in	27.56	8.27	25	22.44	2.56	19.41	1.38	4.69	23.43	7.87	3.15	29.13	13.78	4.72	5.63	3.74	5.91
18	mm	920	210	635	570	65	713	35	119	815	200	80	960	350	120	143	95	150
	in	36.22	8.27	25.00	22.44	2.56	28.07	1.38	4.69	32.09	7.87	3.15	37.80	13.78	4.72	5.63	3.74	5.91
24	mm	920	270	635	570	65	713	35	179	815	260	20	960	350	120	143	95	150
	in	36.22	10.63	25.00	22.44	2.56	28.07	1.38	7.05	32.09	10.24	0.78	37.80	13.78	4.72	5.63	3.74	5.91
36	mm	1140	270	775	710	65	933	35	179	1035	260	20	1180	490	120	143	95	150
	in	44.88	10.63	30.51	27.95	2.56	36.73	1.38	7.05	40.75	10.24	0.78	46.46	19.29	4.72	5.63	3.74	5.91
48	mm	1200	300	865	800	80	968	40	204	1094	288	45	1240	500	175	198	155	210
	in	47.24	11.81	34.06	31.50	3.15	38.11	1.57	8.03	43.07	11.34	1.77	48.82	19.69	6.89	7.80	6.10	8.27

Cassette Units(9K, 12K, 18K)

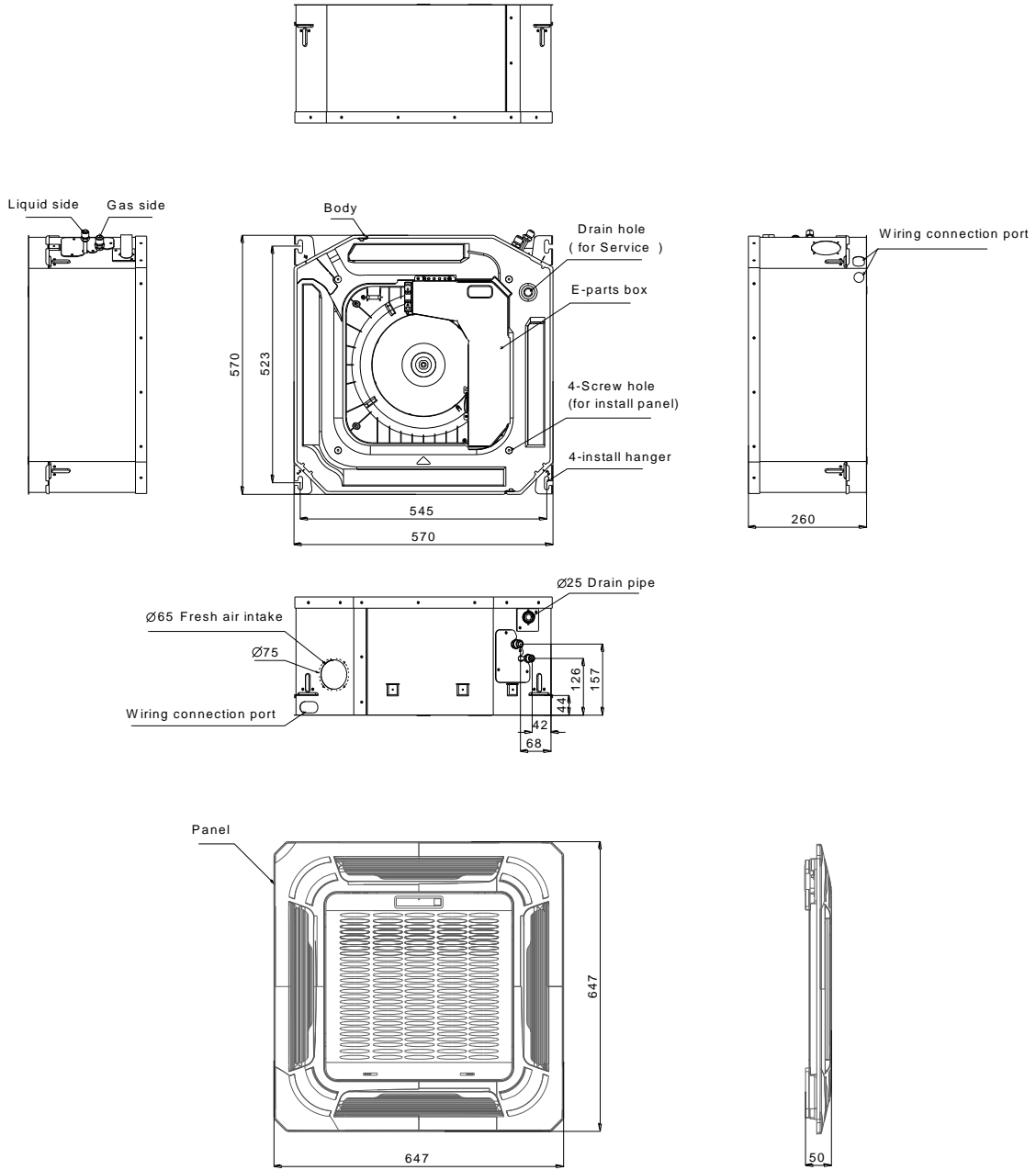

Cassette Units (24K, 36K, 48K)

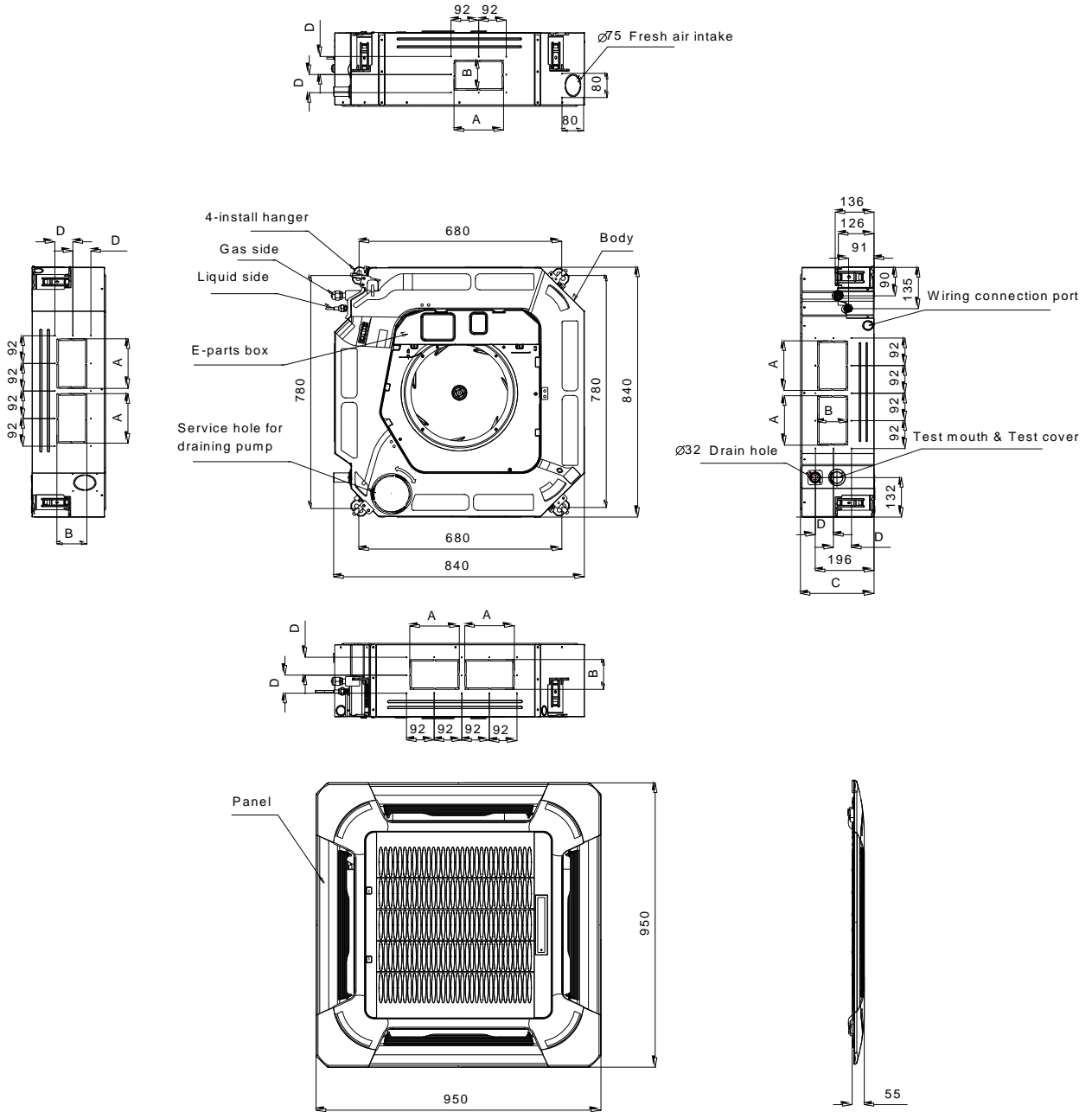

Capacity (Btu/h)		A	B	C	D
24K	mm	160	75	205	50
	inch	6.30	2.95	8.07	1.97
36K	mm	160	95	245	60
	inch	6.30	3.74	9.65	2.36
48K	mm	160	95	287	60
	inch	6.30	3.74	11.30	2.36

Console Units

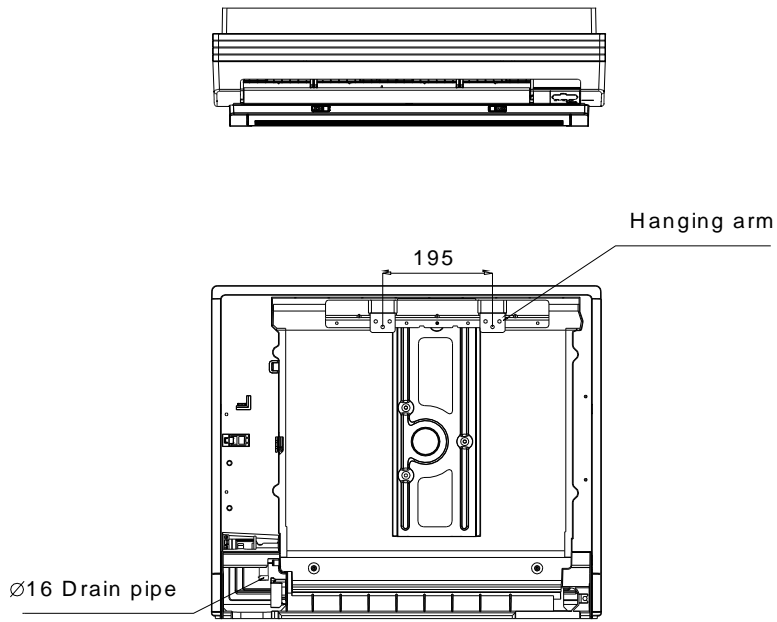
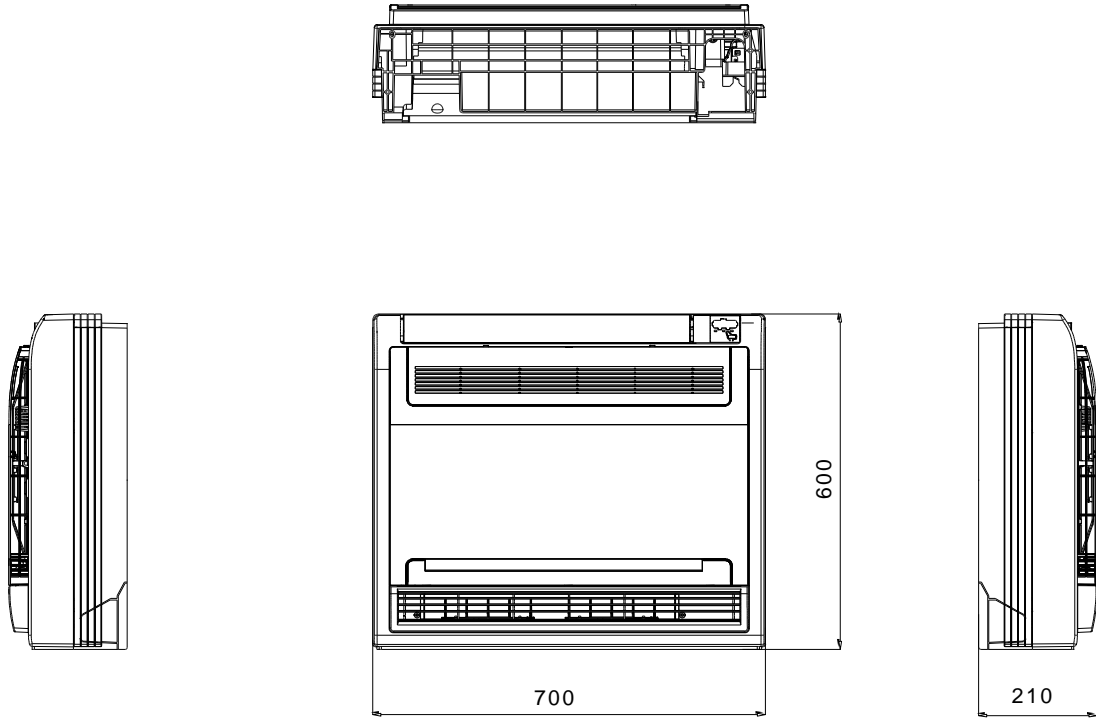

Unit: mm

Ceiling-floor Units (18K-60K)

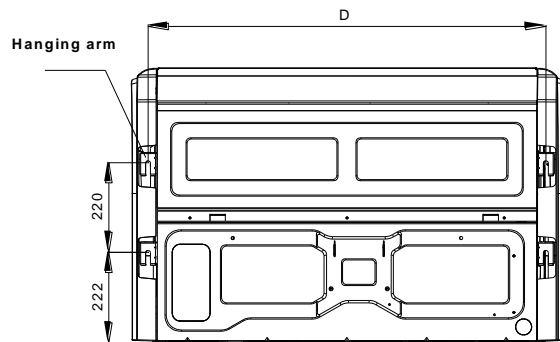
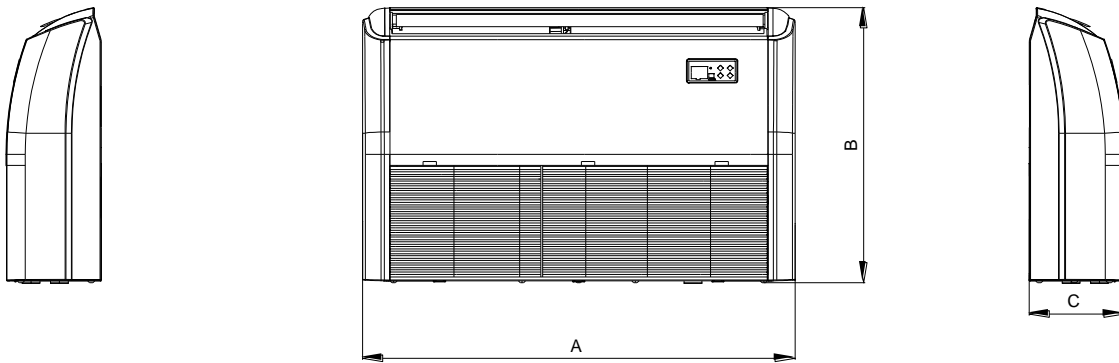
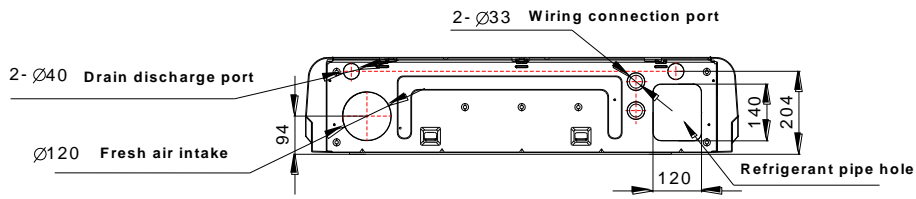

Capacity (Btu/h)		A	B	C	D
18K / 24K	mm	1068	675	235	983
	inch	42.05	26.57	9.25	38.70
36K	mm	1285	675	235	1200
	inch	50.59	26.57	9.25	47.24
48K/60K	mm	1650	675	235	1565
	inch	64.96	26.57	9.25	61.61

A6 Duct Units

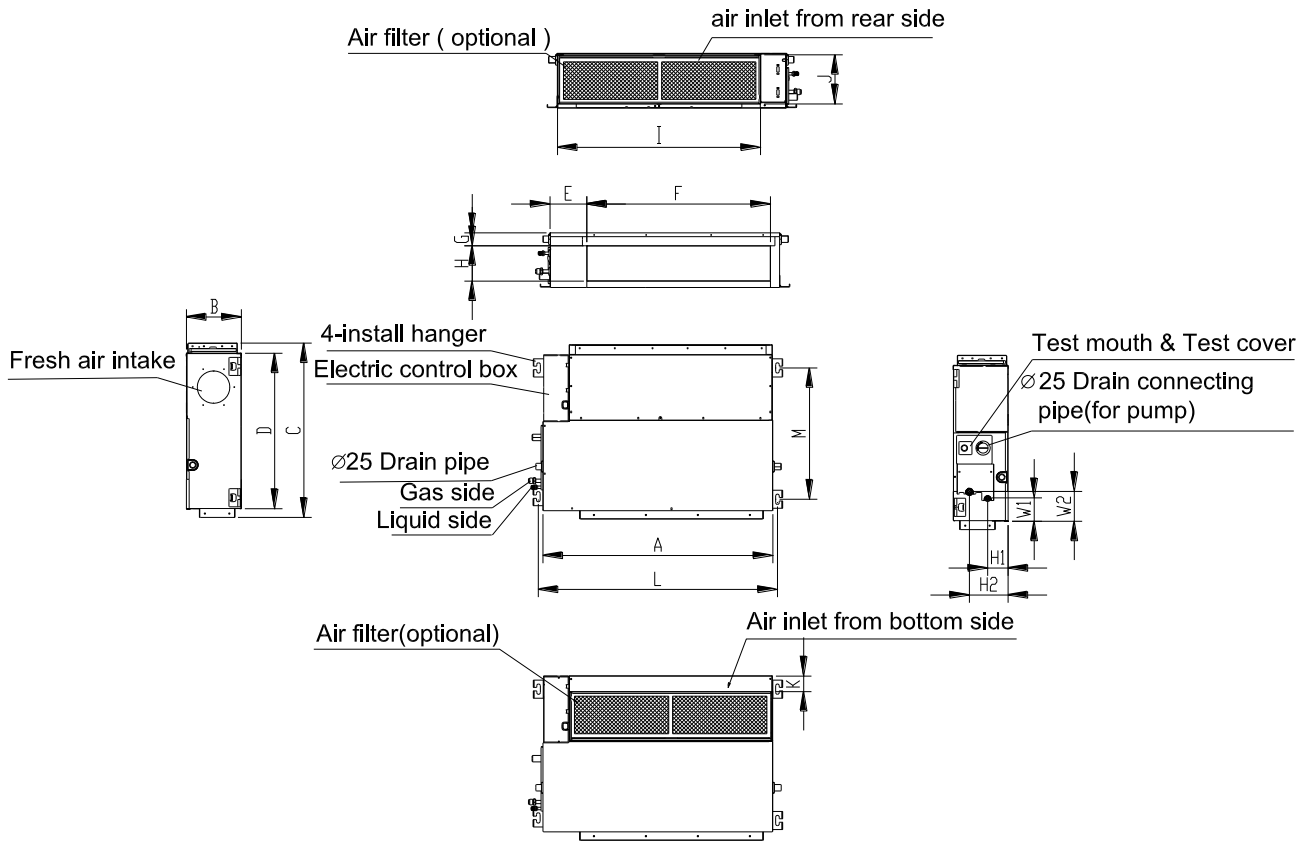

Model (KBtu/h)	unit	A	B	C	D	E	F	G	H	I	J	K	L	M	H1	H2	W1	W2
9/12	mm	700	200	506	450	137	537	30	152	599	186	50	741	360	84	140	84	84
	inch	27.6	7.9	19.9	17.7	5.4	21.1	1.2	6.0	23.6	7.3	2.0	29.2	14.2	3.3	5.5	3.3	3.3
18	mm	880	210	674	600	140	706	50	136	782	190	40	920	508	78	148	88	112
	inch	34.6	8.3	26.5	23.6	5.5	27.8	2.0	5.4	30.8	7.5	1.6	36.2	20.0	3.1	5.8	3.5	4.4
24	mm	1100	249	774	700	140	926	50	175	1001	228	5	1140	598	80	150	130	155
	inch	43.3	9.8	30.5	27.6	5.5	36.5	2.0	6.9	39.4	9.0	0.2	44.9	23.5	3.1	5.9	5.1	6.1
36	mm	1360	249	774	700	140	1186	50	175	1261	228	5	1400	598	80	150	130	155
	inch	53.5	9.8	30.5	27.6	5.5	46.7	2.0	6.9	49.6	9.0	0.2	55.1	23.5	3.1	5.9	5.1	6.1
48	mm	1200	300	874	800	123	1044	50	227	1101	280	5	1240	697	80	150	185	210
	inch	47.2	11.8	34.4	31.5	4.8	41.1	2.0	8.9	43.3	11.0	0.2	48.8	27.4	3.1	5.9	7.3	8.3

MHG-60HWFN1-MW

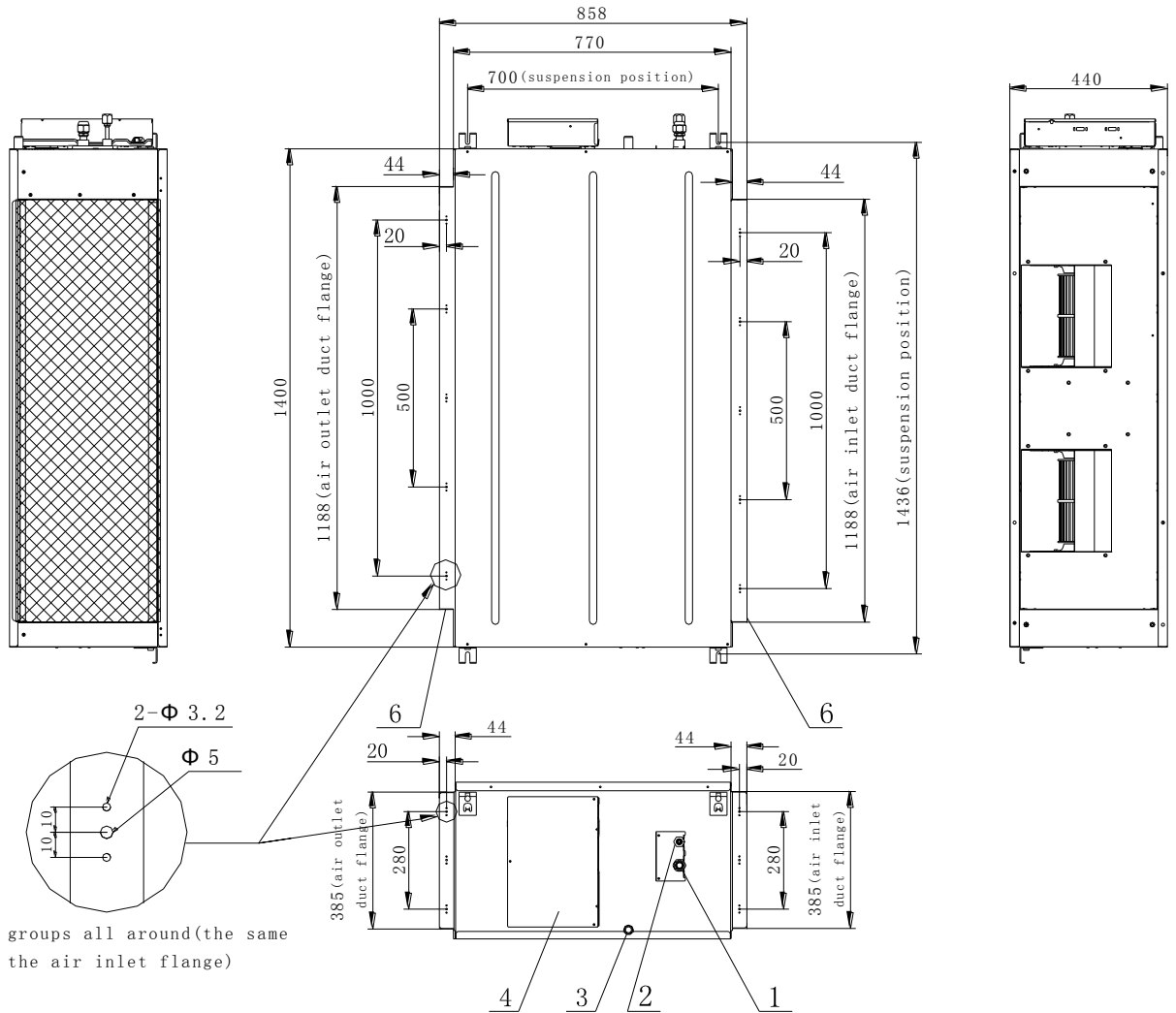

NOTE: 16 groups all around (the same of the air inlet flange)

3.2 Outdoor Unit

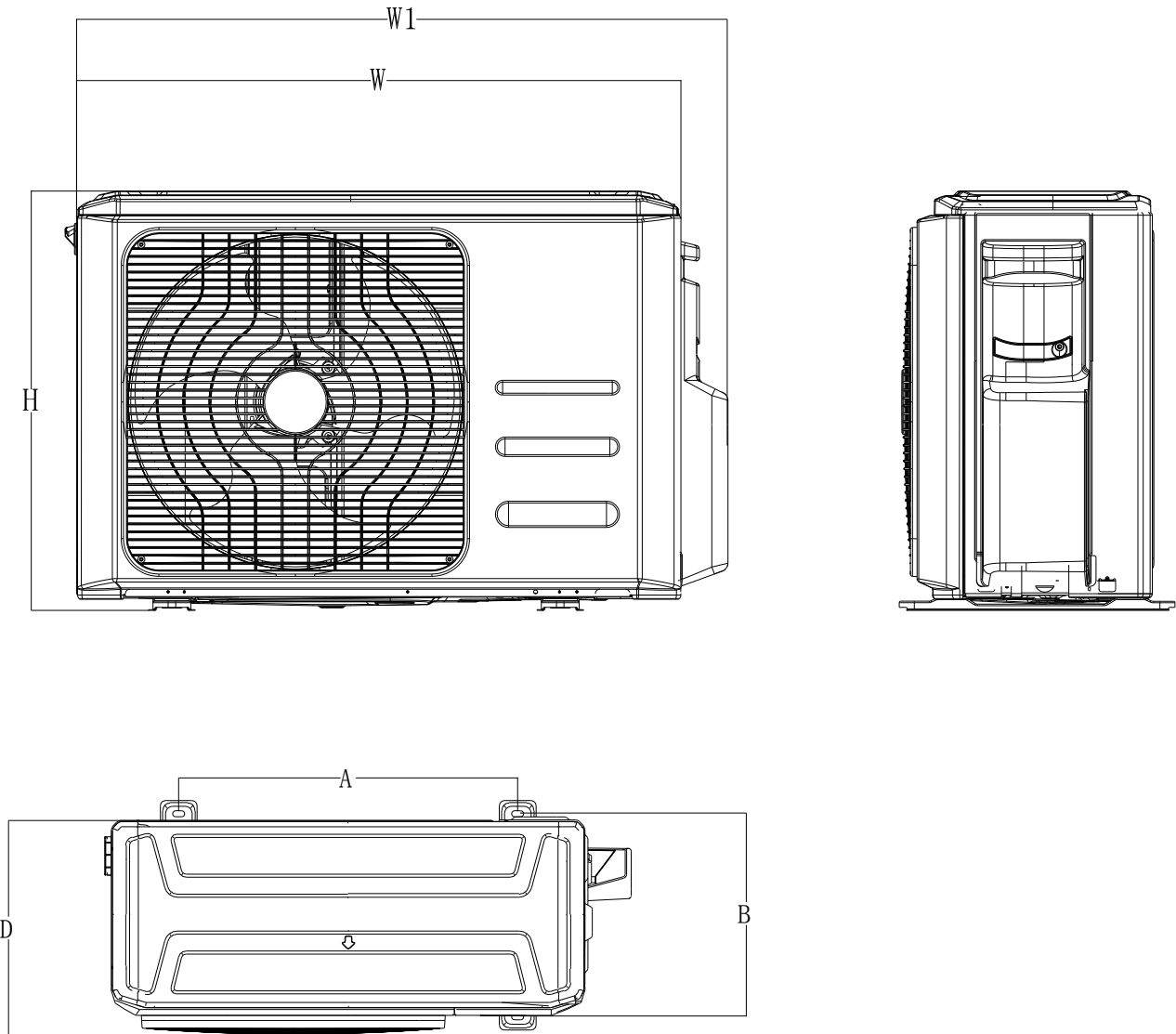

Note: The above drawing is only for reference. The appearance of your units may be different.

Model	unit	W	D	H	W1	A	B
MOBA30-09HFN1-MT0W	mm	770	300	555	840	487	298
	inch	30.3	11.8	21.9	33.1	19.2	11.7
MOB30-09HFN1-MX0W MOB30-12HFN1-MV0W MOB30-12HFN1-MT0W MOB01-09HFN1-MW0W MOB01-12HFN1-MV0W	mm	800	333	554	870	514	340
	inch	31.5	13.1	21.8	34.3	20.2	13.4
MOCA01-18HFN1-MT0W MOCA30-18HFN1-MT0W MOCA31-18HFN1-MT0W	mm	845	363	702	914	540	350
	inch	33.3	14.3	27.6	36.0	21.3	13.8
MOD01-23HFN1-MT0W	mm	946	420	810	1030	673	403
	inch	37.2	16.5	31.9	40.6	26.5	15.9
MOD30-24HFN1-MT0W	mm	946	410	810	1030	673	403

MOD31-24HFN1-MT0W MOD30U-36HFN1-M	inch	37.2	16.1	31.9	40.6	26.5	15.9
--------------------------------------	------	------	------	------	------	------	------

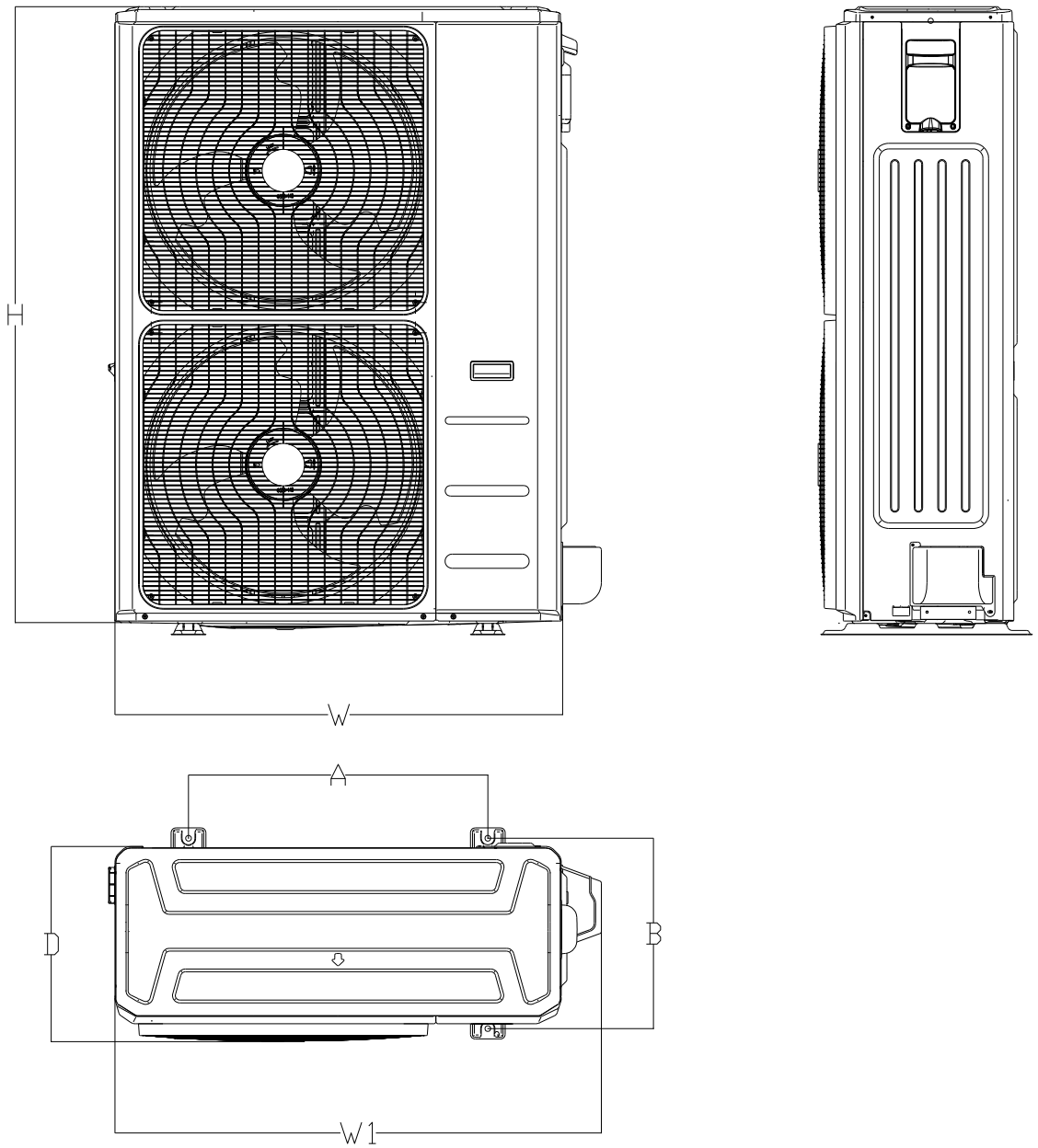

Model		W	D	H	W1	A	B
MOE30U-48HFN1-M	mm	952	415	1333	1045	634	404
MOE30U-60HFN1-M	inch	37.5	16.3	52.5	41.1	25.0	15.9

4. Service Space

4.1 Indoor Unit

A5/A6 Duct Units

Ensure enough space required for installation and maintenance.

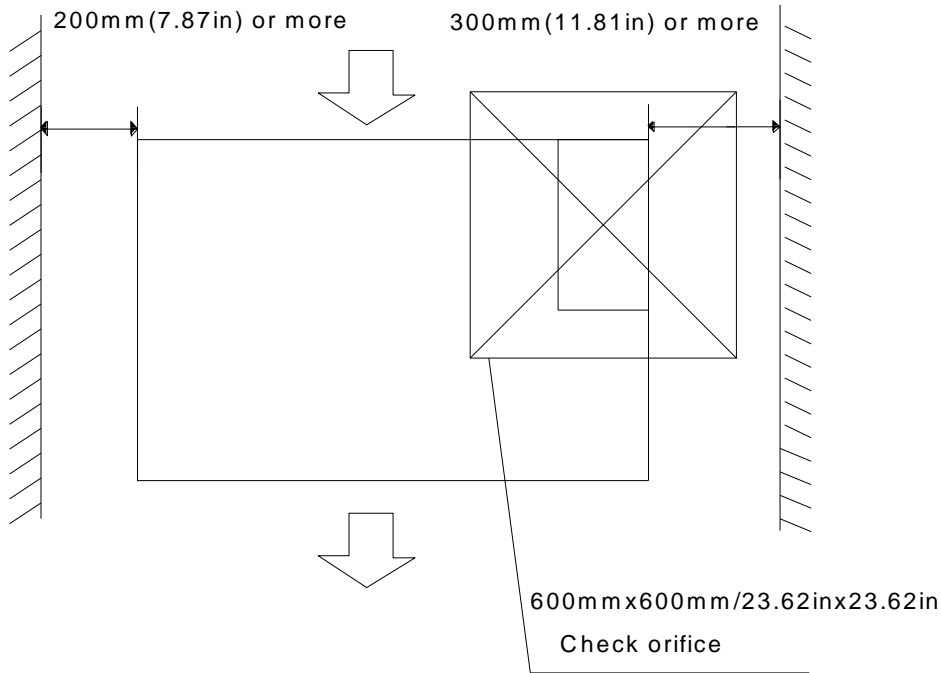

All the indoor units reserve the hole to connect the fresh air pipe. The hole size as following

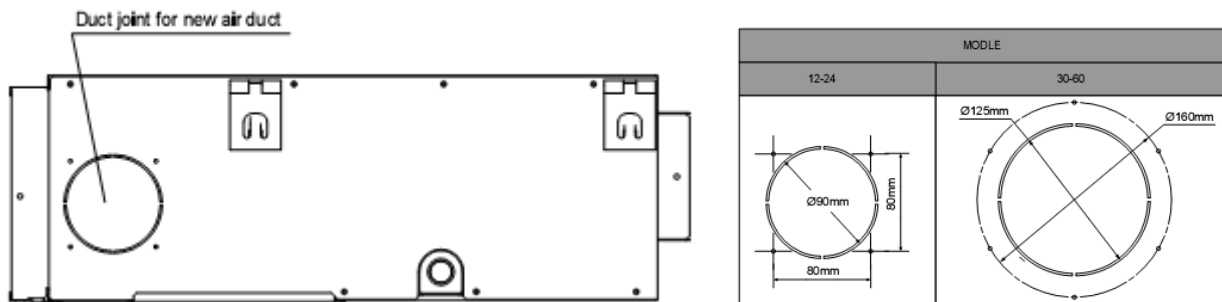

Cassette Units

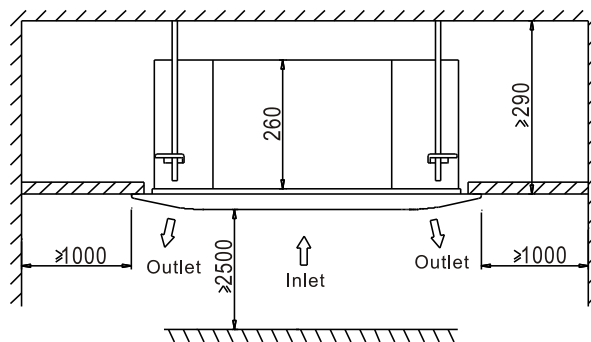

Unit: mm

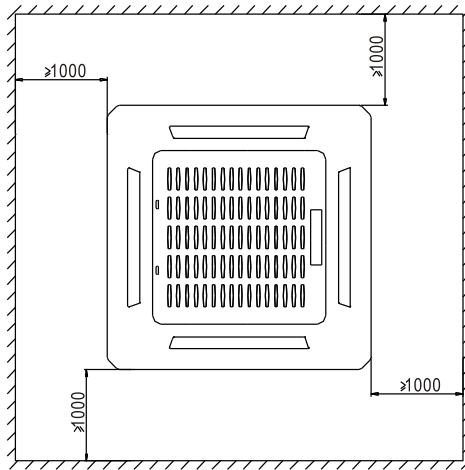

Console Units

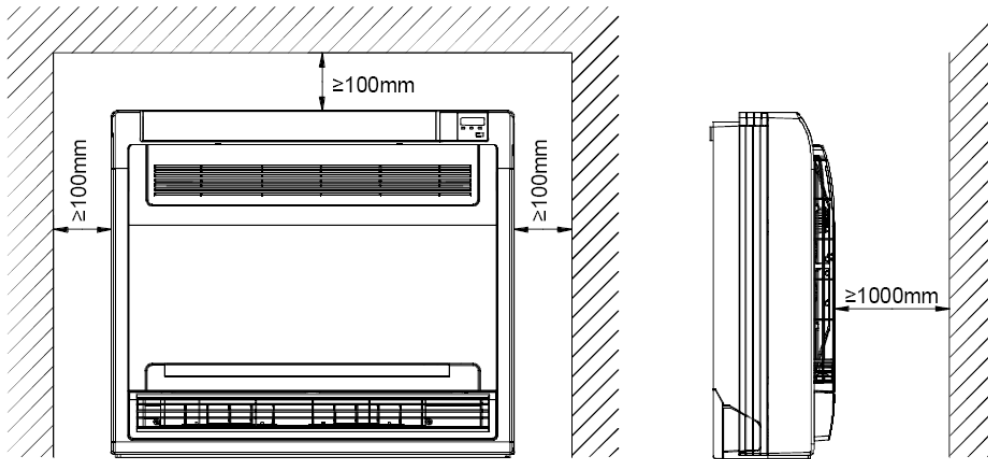

Ceiling-floor Units

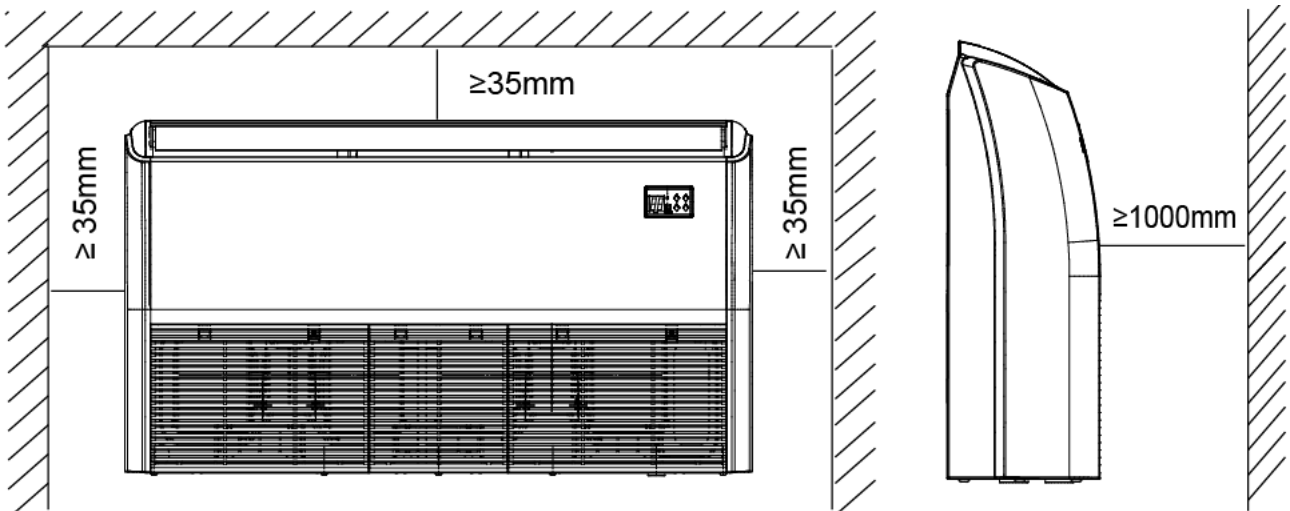

HESP DUCT

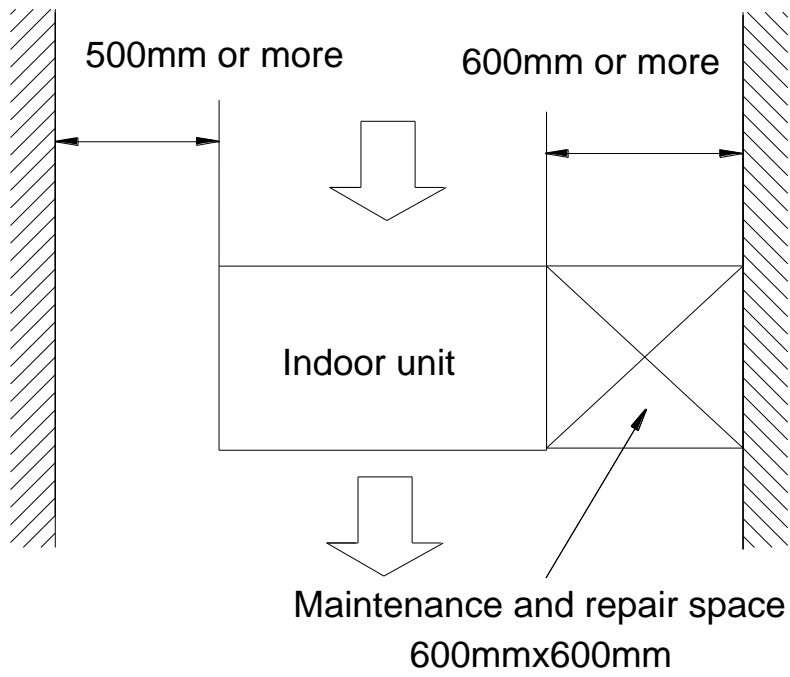

4.2 Outdoor Unit

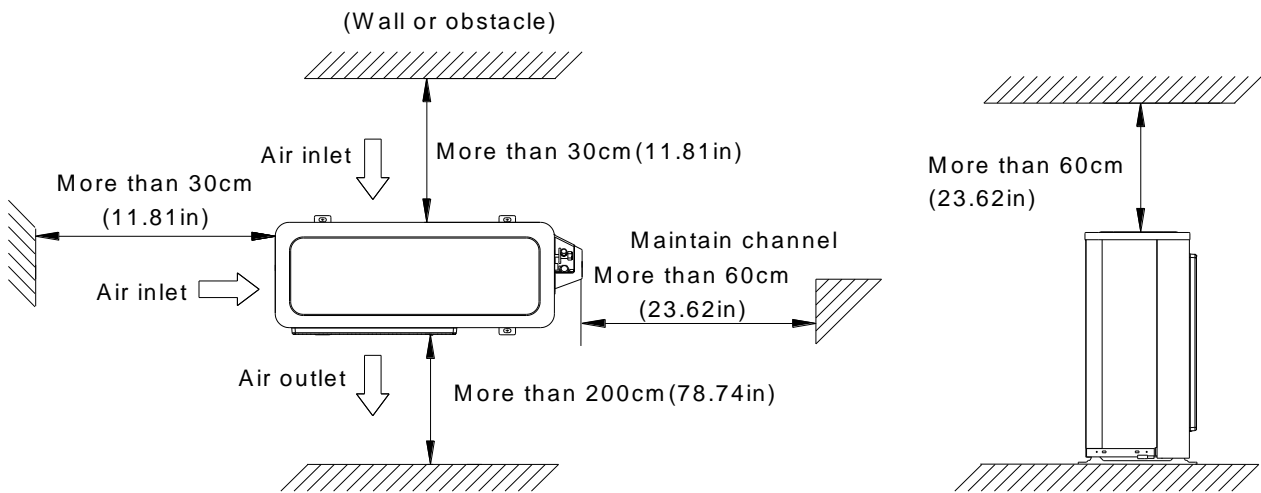

5. Refrigerant Cycle Diagram

MOCA30-18HFN1-MT0W, MOCA01-18HFN1-MT0W, MOD30-24HFN1-MT0W,
MOD01-23HFN1-MT0W, MOD31-24HFN1-MT0W

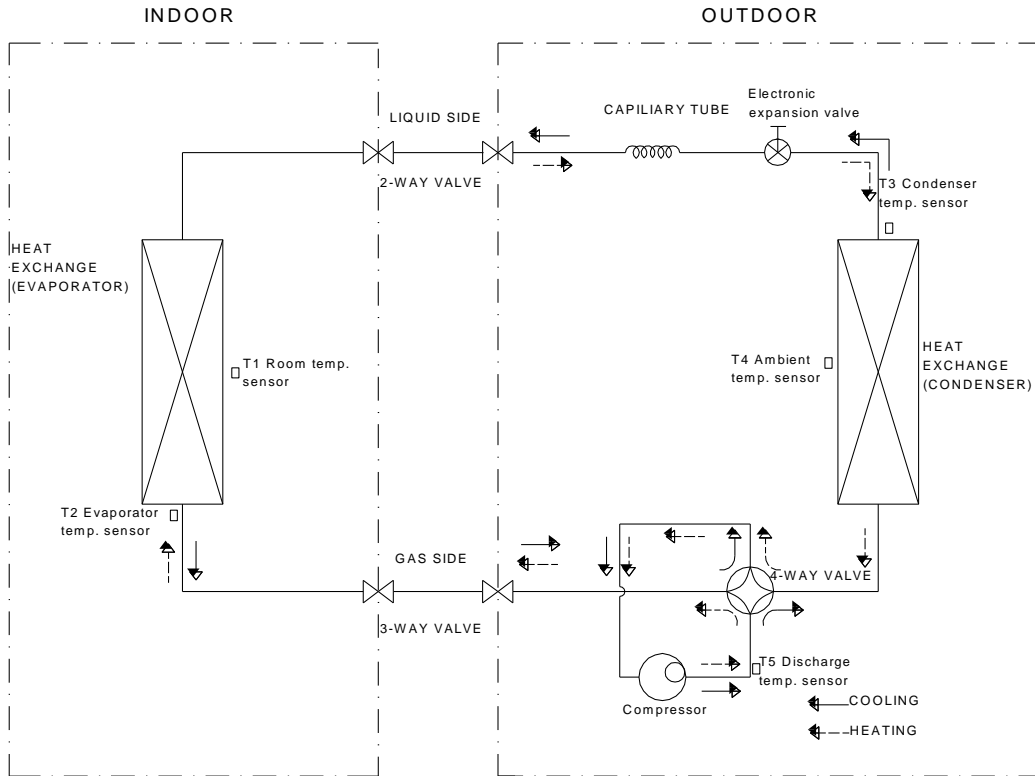

MOB30-09HFN1-MX0W, MOB01-09HFN1-MW0W, MOB30-12HFN1-MV0W, MOB01-12HFN1-MV0W
MOBA30-09HFN1-MT0W, MOB30-12HFN1-MT0W, MOCA31-18HFN1-MT0W

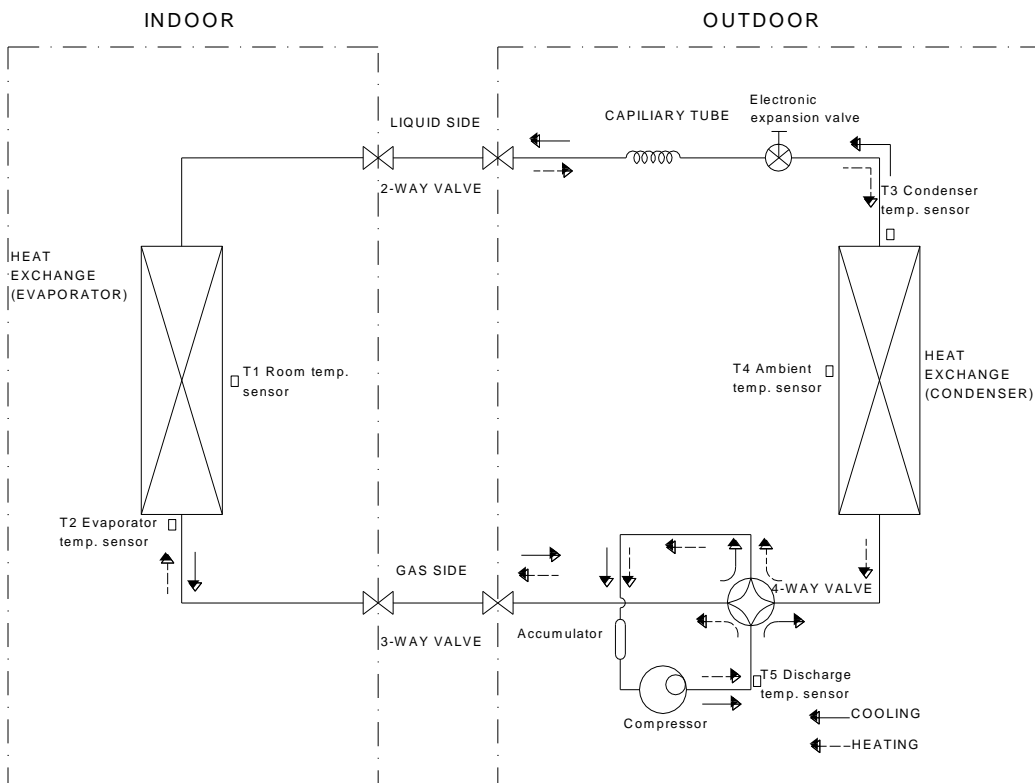

MOD30U-36HFN1-M, MOE30U-48HFN1-M, MOE30U-60HFN1-M

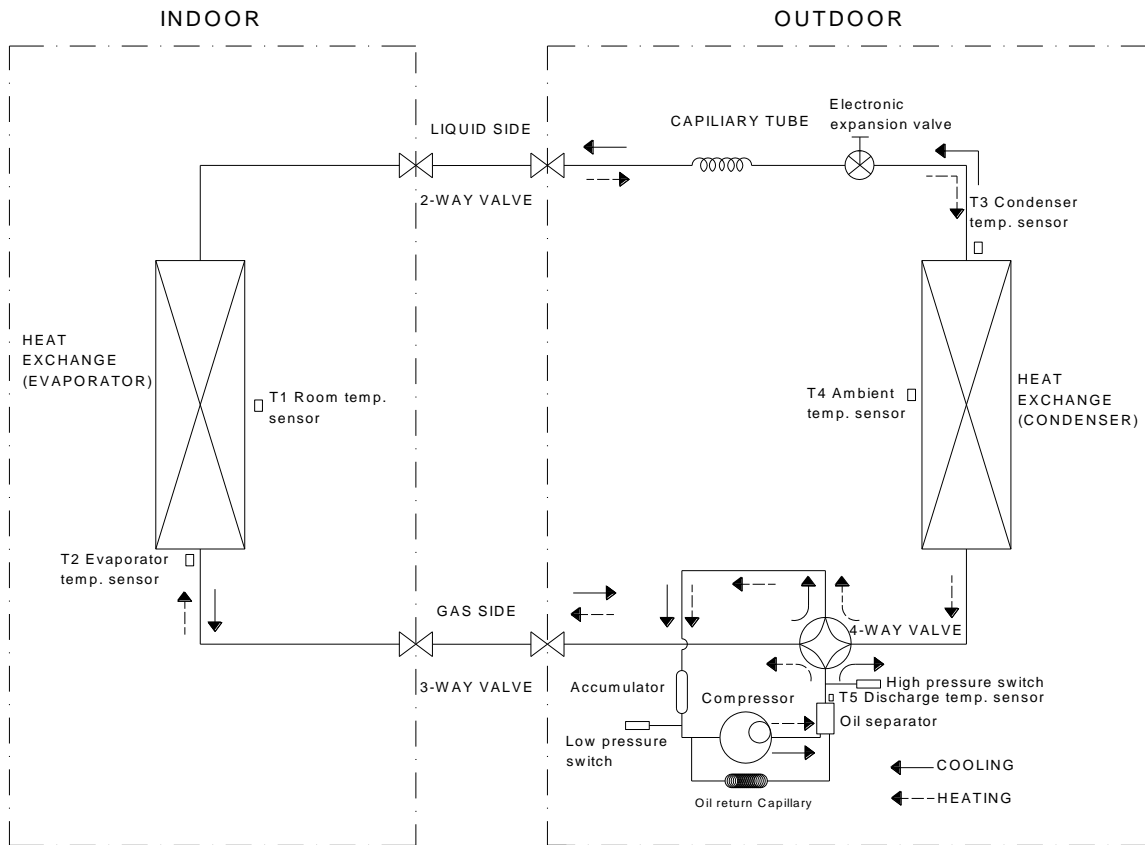

6. Wiring Diagram

6.1 Indoor Unit

CCA3U-09HRFN1-M(C), CCA3U-12HRFN1-M(C), CCA3U-18HRFN1-M(C), MCD-24HRFN1-M(C)

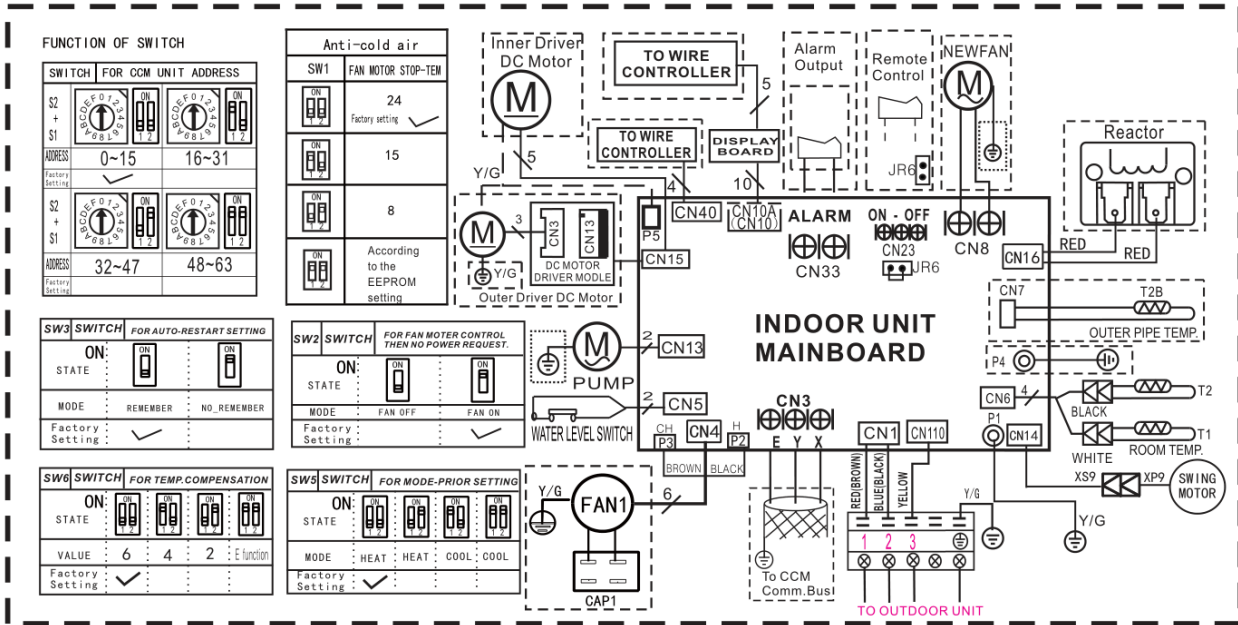

CTBU-09HWFN1-M(C), CTBU-12HWFN1-M(C), CTBU-18HWFN1-M(C), CTBU-24HWFN1-M(C)

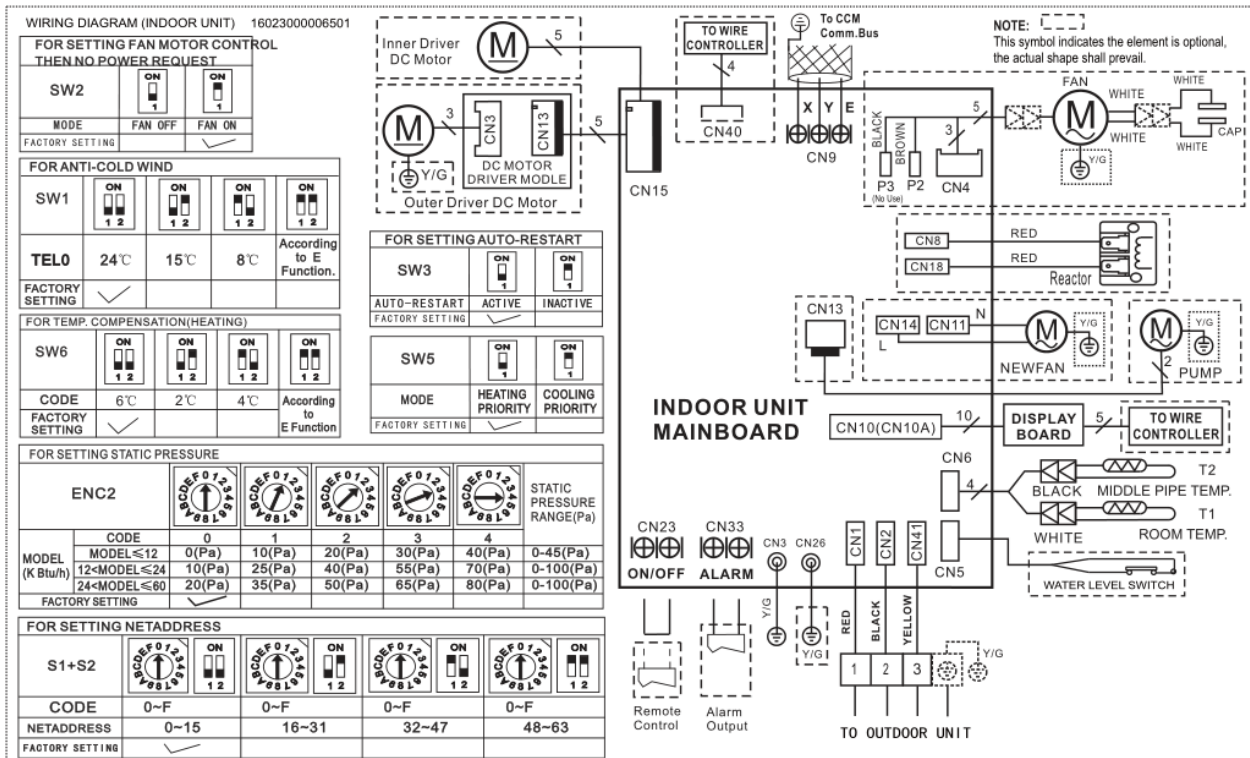

CFAU-09HRFN1-M(C), CFAU-12HRFN1-M(C)

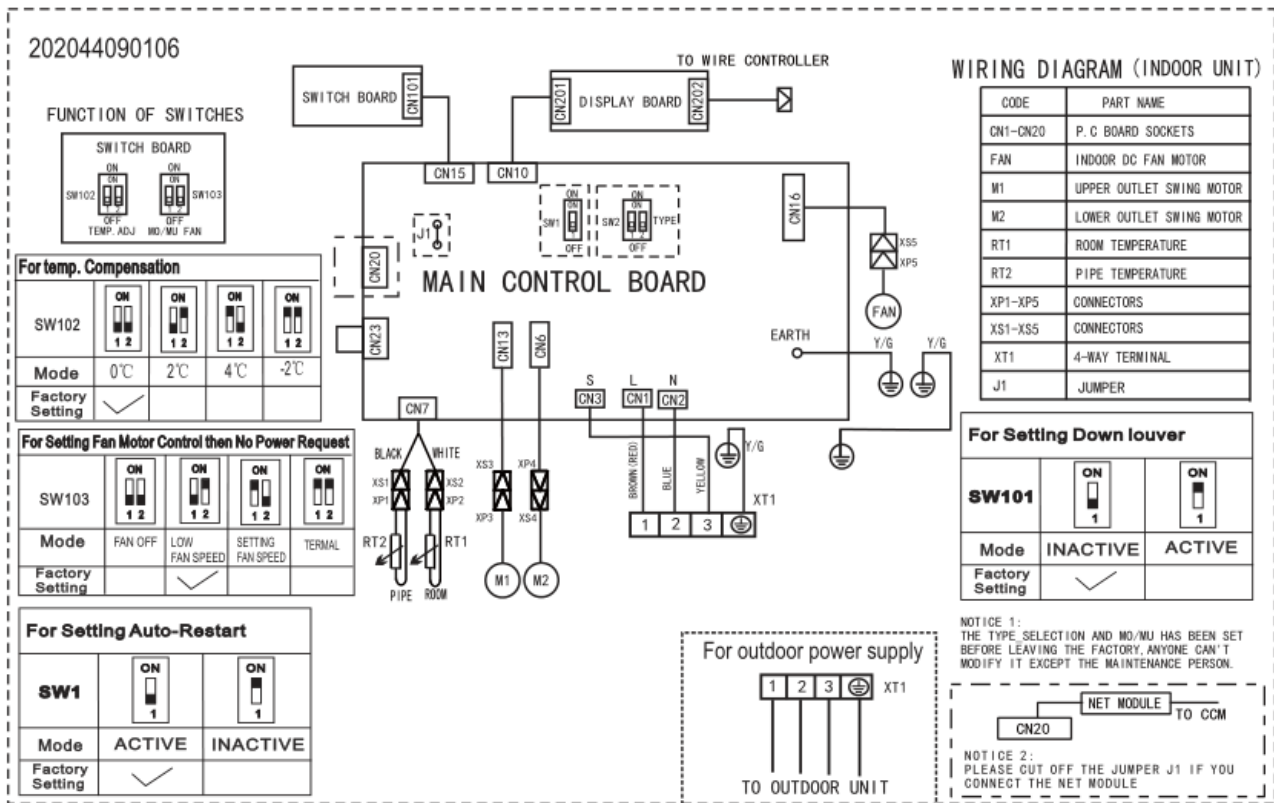

MCD-36HRFN1-M(C), MCD-48HRFN1-M(D)

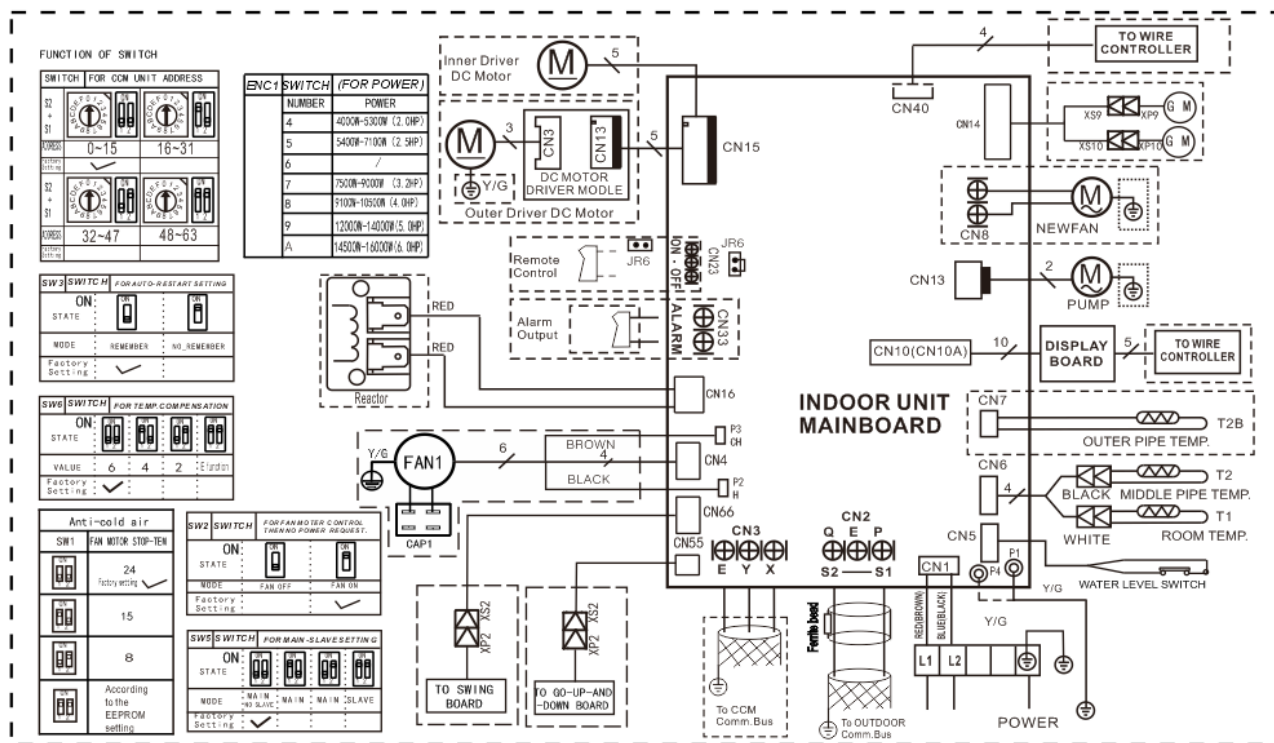

CTBU-36HWFN1-M(C), CTBU-48HWFN1-M(C)

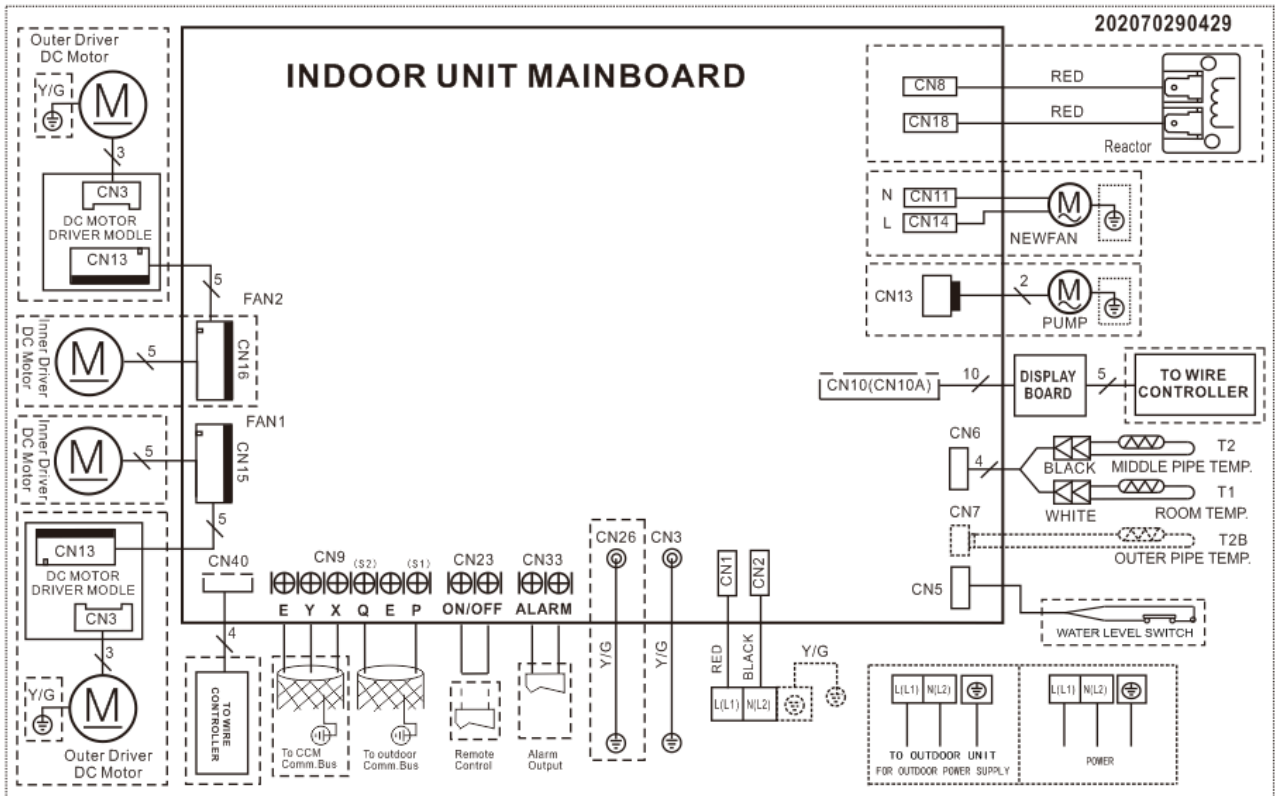

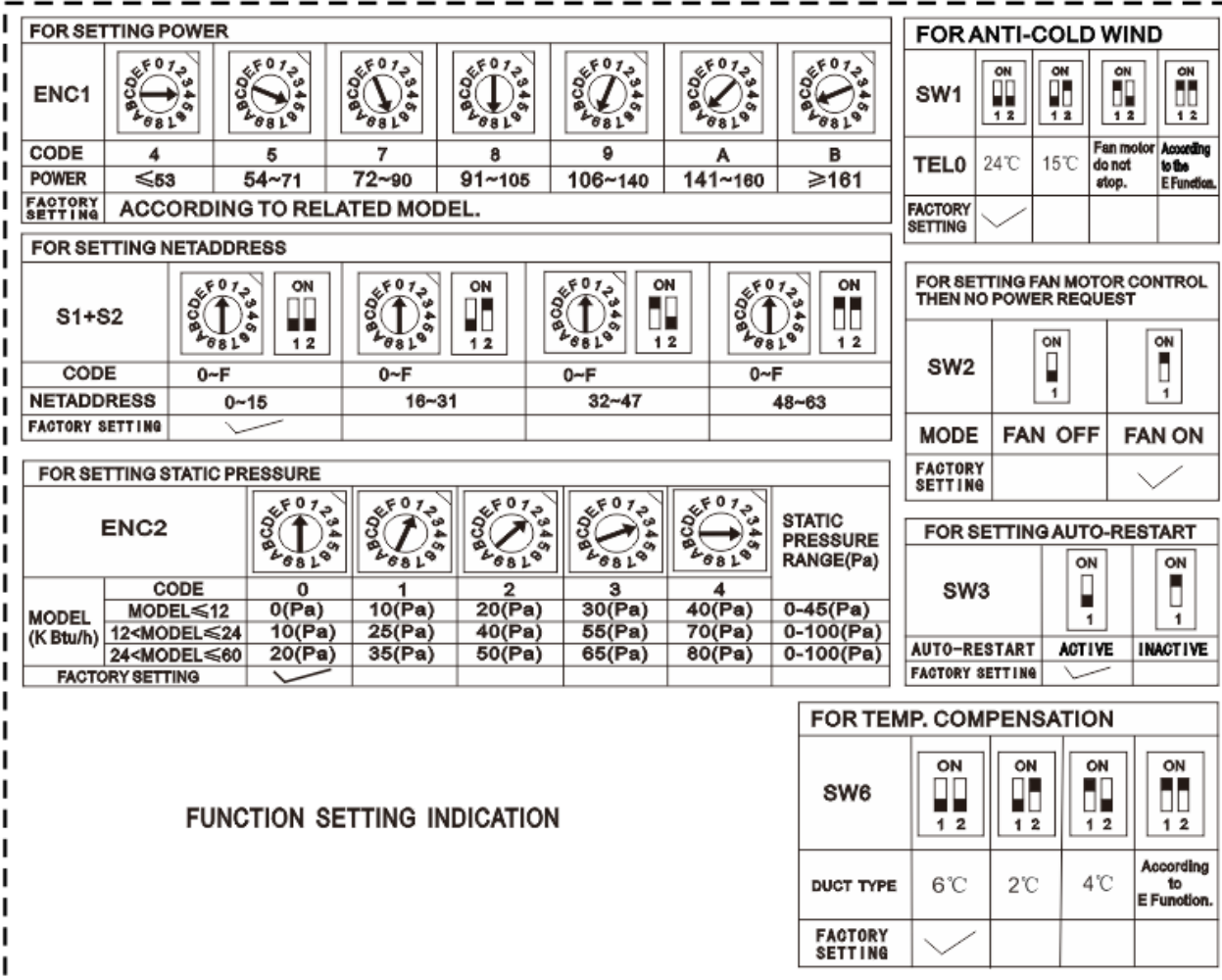

FUNCTION SETTING INDICATION

MUEU-18HRFN1-M(C), MUEU-24HRFN1-M(C)

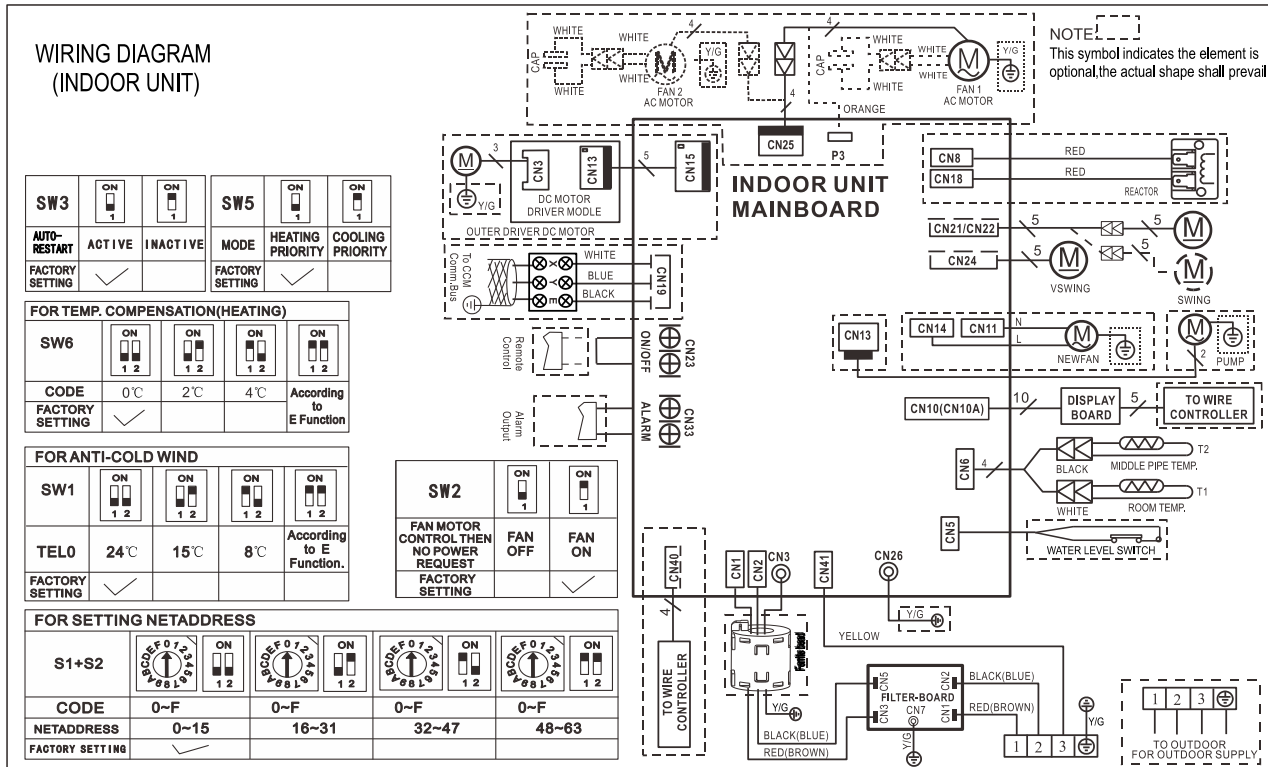

MUE-36HRFN1-M(C)

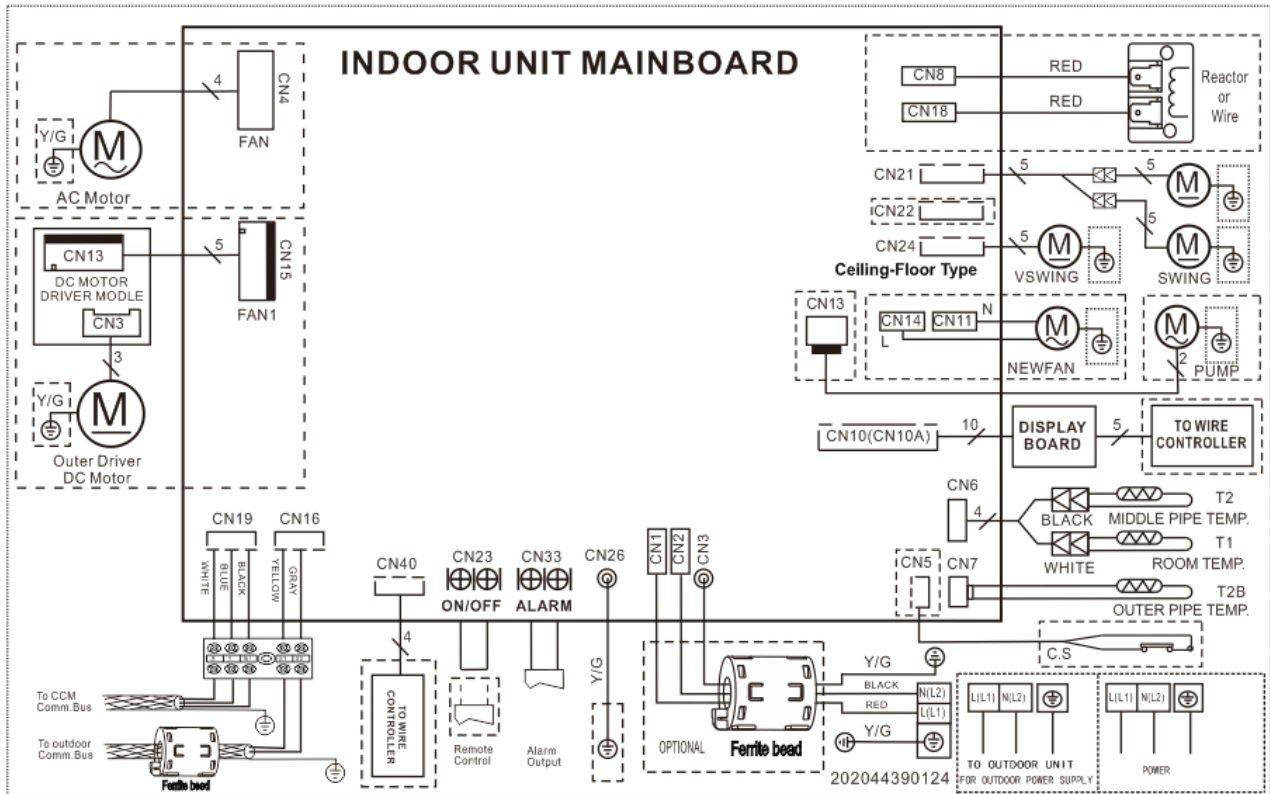

MUE-48HRFN1-M(C)

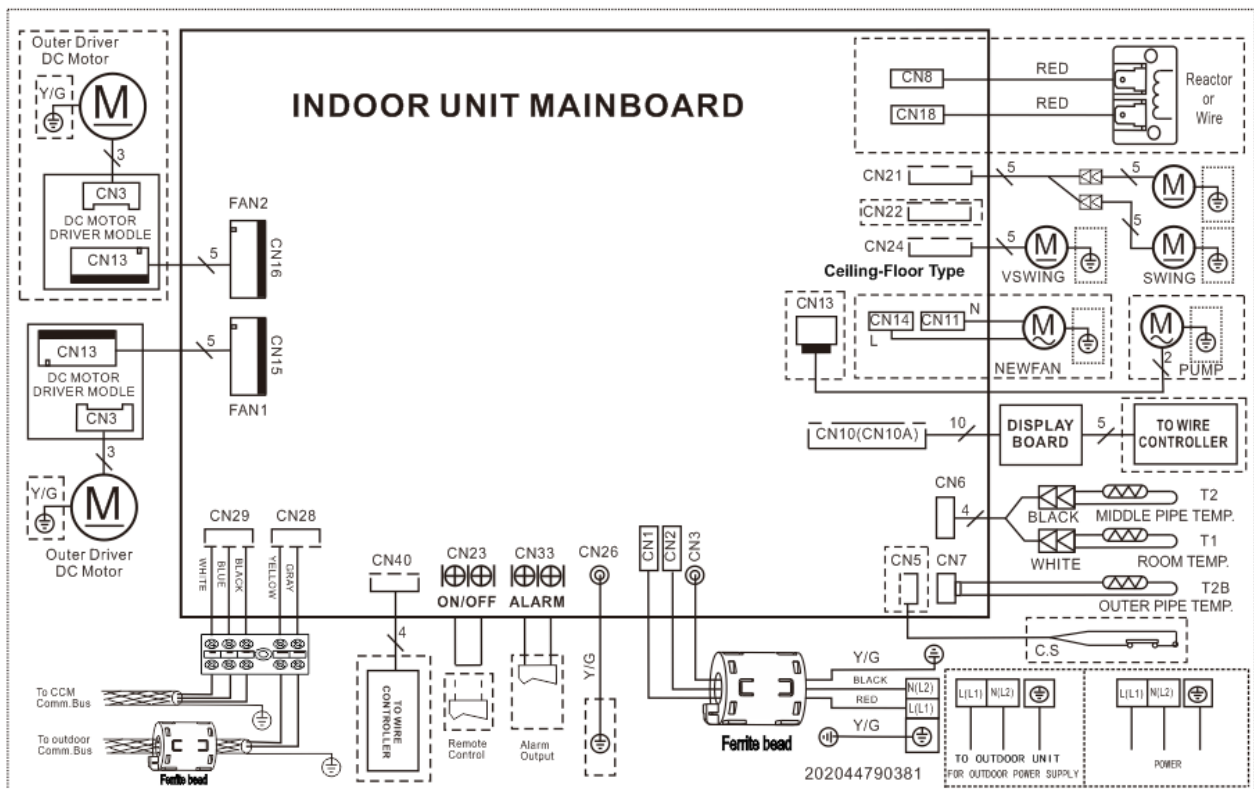

MUE-60HRFN1-MW

16022700002748

FOR ANTI-COLD WIND(HEATING)				
SW1	<input type="checkbox"/> ON <input type="checkbox"/> 1 2	<input type="checkbox"/> ON <input type="checkbox"/> 1 2	<input type="checkbox"/> ON <input type="checkbox"/> 1 2	<input type="checkbox"/> ON <input type="checkbox"/> 1 2
TELO	24°C	15°C	8°C	EEPROM default
FACTORY SETTING	<input checked="" type="checkbox"/>			

FOR SETTING AUTO-RESTART		
SW3	<input type="checkbox"/> ON <input type="checkbox"/> 1	<input type="checkbox"/> ON <input type="checkbox"/> 1
MODE	ACTIVE	INACTIVE
FACTORY SETTING	<input checked="" type="checkbox"/>	

FOR SETTING FAN QUANTITY		
SW4	<input type="checkbox"/> ON <input type="checkbox"/> 1	<input type="checkbox"/> ON <input type="checkbox"/> 1
MODE	Single Fan	Double Fan
Factory Setting	<input checked="" type="checkbox"/>	







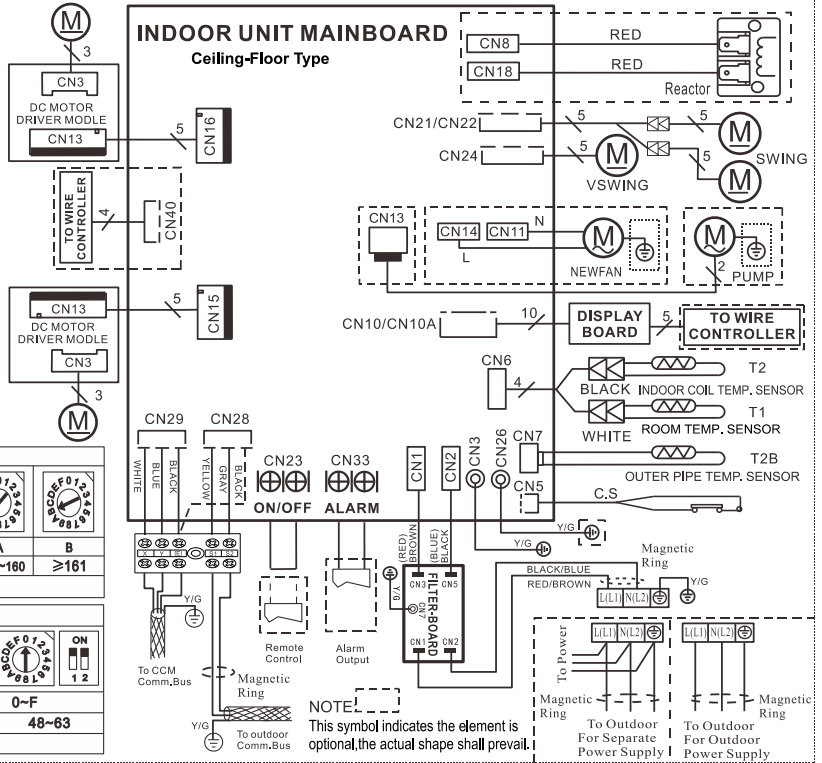





















FOR TEMP. COMPENSATION(HEATING)				
SW6	<input type="checkbox"/> ON <input type="checkbox"/> 1 2	<input type="checkbox"/> ON <input type="checkbox"/> 1 2	<input type="checkbox"/> ON <input type="checkbox"/> 1 2	<input type="checkbox"/> ON <input type="checkbox"/> 1 2
CODE	0°C	2°C	4°C	EEPROM default
FACTORY SETTING	<input checked="" type="checkbox"/>			

FOR SETTING POWER						
ENC1						
CODE	4	5	7	8	9	A B
POWER	≤53	54~71	72~90	91~105	106~140	141~160 ≥161
FACTORY SETTING	FACTORY USE ONLY.					

FOR SETTING NETADDRESS				
S1+S2		<input type="checkbox"/> ON <input type="checkbox"/> 1 2		<input type="checkbox"/> ON <input type="checkbox"/> 1 2
CODE	0~F	0~F	0~F	0~F
NETADDRESS	0~15	16~31	32~47	48~63
FACTORY SETTING	<input checked="" type="checkbox"/>			



MUE-36HRFN1-M(C),MUE-48HRFN1-M(C)

For Setting NETAddress				FOR ANTI-COLD WIND							
S1+S2	 	 	 	 	SW1						
Code	0~F 00	0~F 01	0~F 10	0~F 11	TELO	24℃	15℃	Fan motor do not stop.	According to the E Function.		
NETAddress	0~15	16~31	32~47	48~63	FACTORY SETTING	<input checked="" type="checkbox"/>					
Factory Setting	<input checked="" type="checkbox"/>										
FOR SETTING POWER				FOR SETTING AUTO-RESTART							
ENC1								SW3			
CODE	4	5	7	8	9	A	B	AUTO-RESTART	ACTIVE	INACTIVE	
POWER	≤53	54~71	72~90	91~105	106~140	141~160	≥161	FACTORY SETTING	<input checked="" type="checkbox"/>		
FACTORY SETTING	ACCORDING TO RELATED MODEL.										
For temp. compensation				For Setting Fan Quantity (optional)				For Setting Fan Motor Control then No Power Request			
SW6					SW4			SW2			
CEILING AND FLOOR TYPE	0℃	2℃	4℃	According to E Function	Mode	Single Fan	Double Fan	Mode	Fan OFF	Fan ON	
For Setting CEILING TYPE or FLOOR TYPE	FLOOR TYPE	CEILING TYPE		Factory Setting	Factory Setting	<input checked="" type="checkbox"/>		Factory Setting	<input checked="" type="checkbox"/>		
Factory Setting	<input checked="" type="checkbox"/>										

FUNCTION SETTING INDICATION
202044690388

MTIU-09HWFN1-M, MTIU-12HWFN1-M, MTIU-18HWFN1-M, MTIU-24HWFN1-M

1602300007041
 WIRING DIAGRAM
 (INDOOR UNIT)

NOTE:
 1.The parts with dotted line indicates optional features.
 2.Remove the short connector of J7 when you use the "on-off" function.

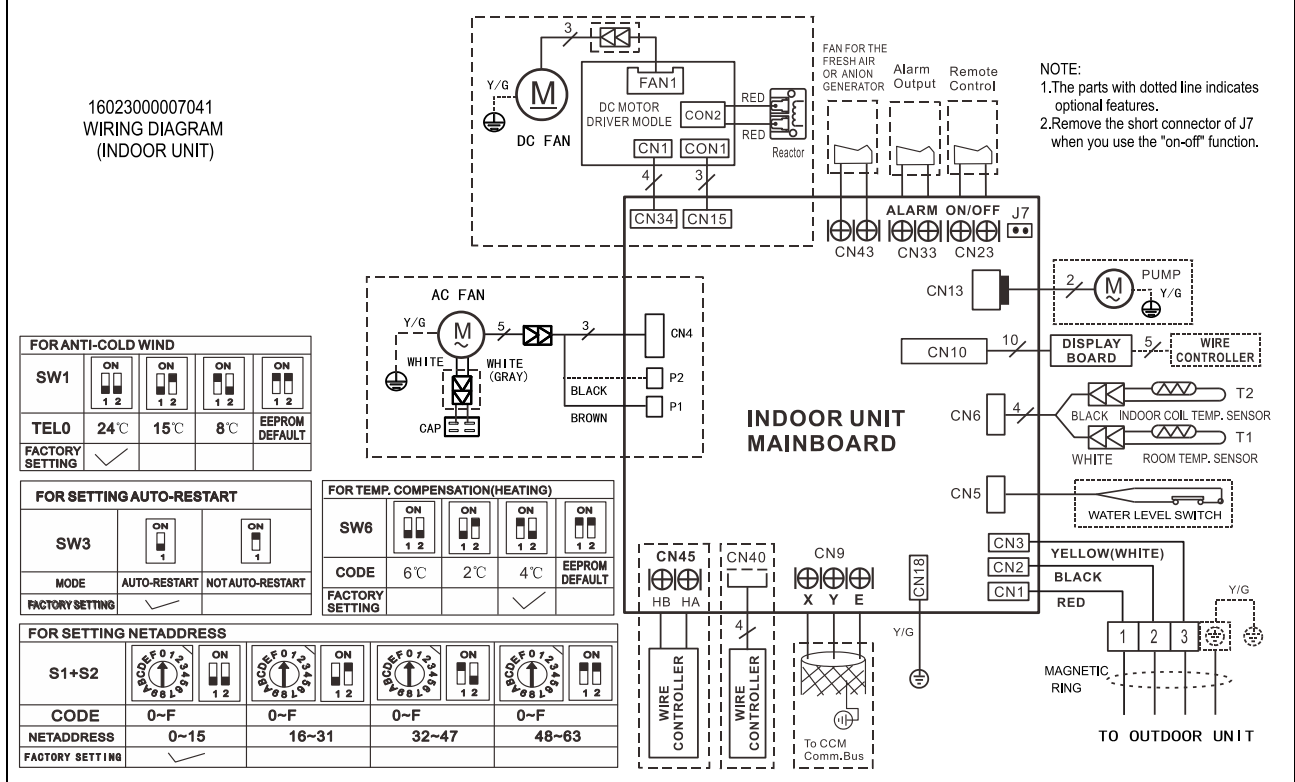

MTI-36HWFN1-M , MTI-48HWFN1-M, MHG-60HWFN1-MW

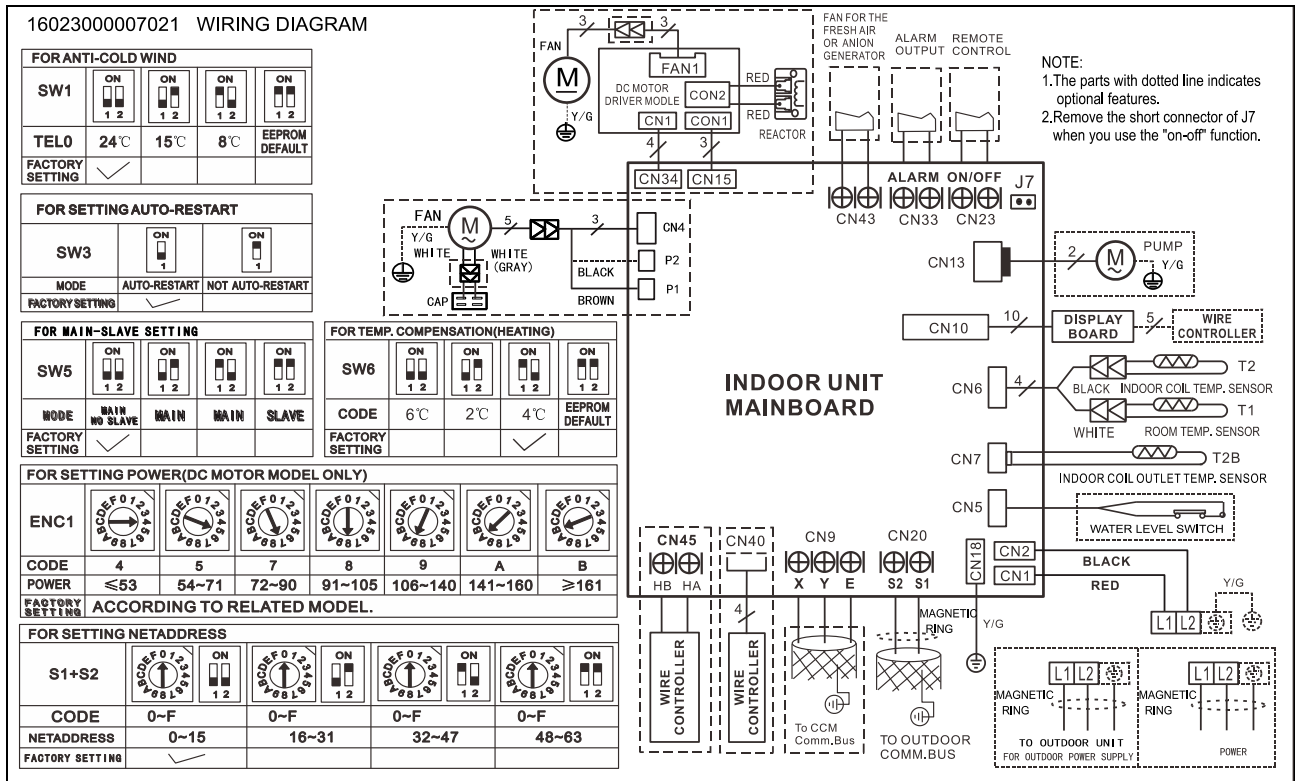

6.1.1 Some connectors introduce:

CCA3U-09HRFN1-M(C), CCA3U-12HRFN1-M(C), CCA3U-18HRFN1-M(C), MCD-24HRFN1-M(C), MCD-36HRFN1-M(C), MCD-48HRFN1-M(D)

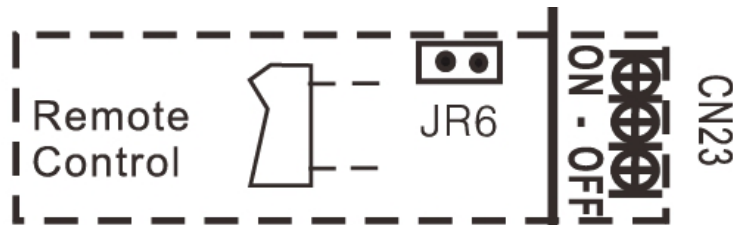

A For remote control (ON-OFF) terminal port CN23 and short connector of JR6

1. Remove the short connector of JR6 when you use ON-OFF function;
2. When remote switch off (OPEN), the unit would be off;
3. When remote switch on (CLOSE), the unit would be on;
4. When close/open the remote switch, the unit would be responded the demand within 2 seconds;
5. When the remote switch on. you can use remote controller/ wire controller to select the mode what you want ;when the remote switch off , the unit would not respond the demand from remote controller/wire controller.

When the remote switch off, but the remote controller / wire controller are on, CP code would be shown on the display board.

6. The voltage of the port is 12V DC , design Max. current is 5mA.

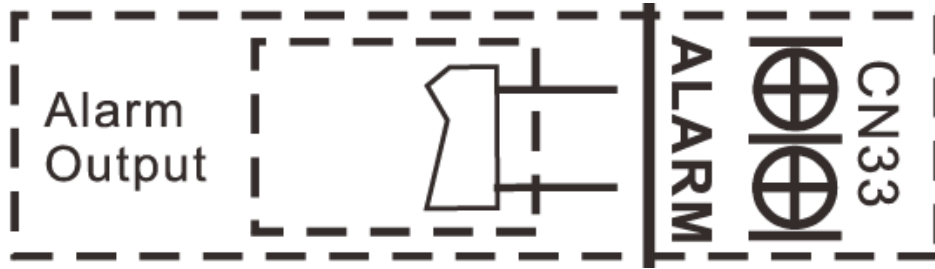
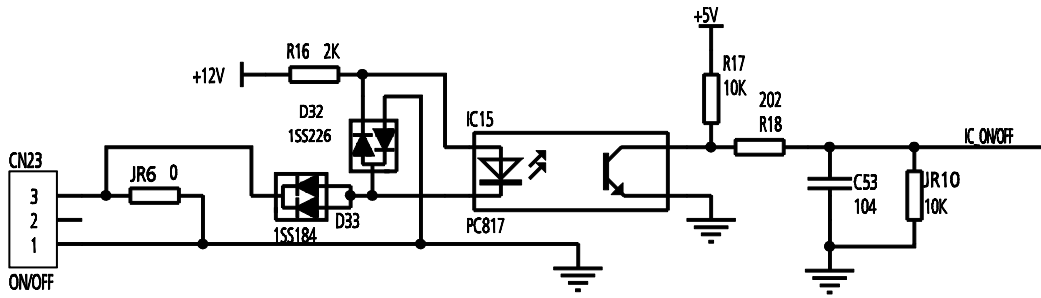

B For ALARM terminal port CN33

1. Provide the terminal port to connect ALARM ,but no voltage of the terminal port , the power from the ALARM system (not from the unit)
2. Although design voltage can support higher voltage, but we strongly ask you connect the power less than 24V, current less than 0.5A
3. When the unit occurs the problem, the relay would be closed, then ALARM works

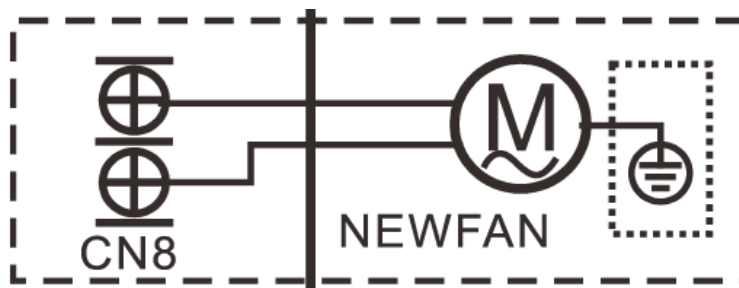
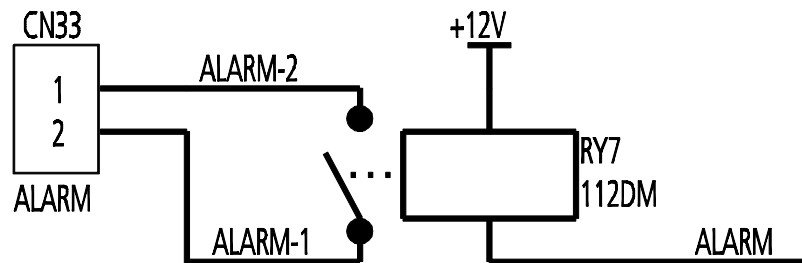

C. For new fresh motor terminal port CN8

1. Connect the fan motor to the port, no need care L/N of the motor;
2. The output voltage is the power supply;
3. The fresh motor cannot exceed 200W or 1A, follow the smaller one ;

4. The new fresh motor will be worked when the indoor fan motor work ;when the indoor fan motor stops , the new fresh motor would be stopped ;
5. When the unit enter force cooling mode or capacity testing mode, the fresh motor isn't work .

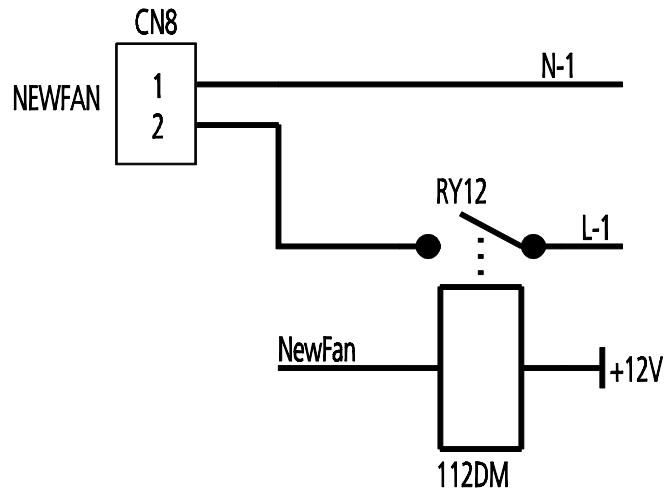

**CTBU-09HWFN1-M(C), CTBU-12HWFN1-M(C), CTBU-18HWFN1-M(C),CTBU-24HWFN1-M(C),
CTBU-36HWFN1-M(C), CTBU-48HWFN1-M(C), MUEU-18HRFN1-M(C), MUEU-24HRFN1-M(C),
MUE-36HRFN1-M(C), MUE-48HRFN1-M(C), MUE-60HRFN1-MW**

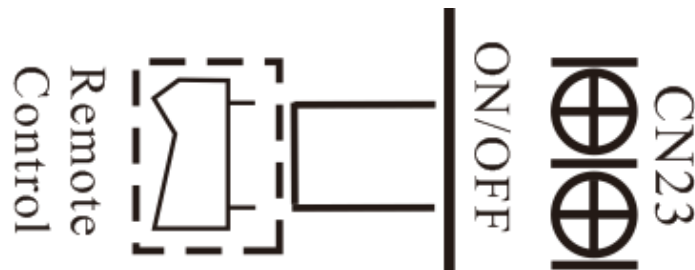

A For remote control (ON-OFF) terminal port CN23

1. Remove the short connector in CN23 when you use ON-OFF function;
2. When remote switch off (OPEN), the unit would be off;
3. When remote switch on (CLOSE), the unit would be on;
4. When close/open the remote switch, the unit would be responded the demand within 2 seconds;
5. When the remote switch on. You can use remote controller/wire controller to select the mode what you want; when the remote switch off, the unit would not respond the demand from remote controller/wire controller.

When the remote switch off, but the remote controller/wire controller are on, CP code would be shown on the display board.

6. The voltage of the port is 12V DC, design Max. current is 5mA.

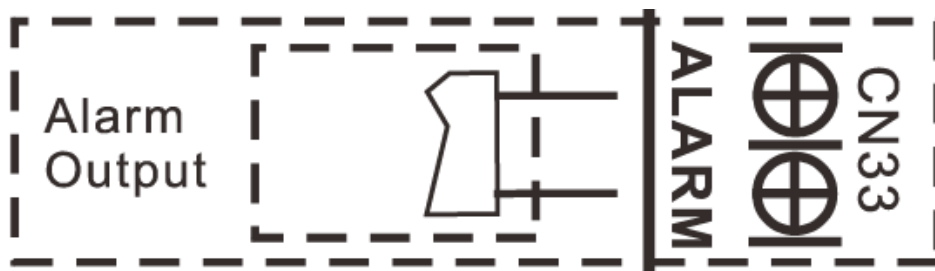
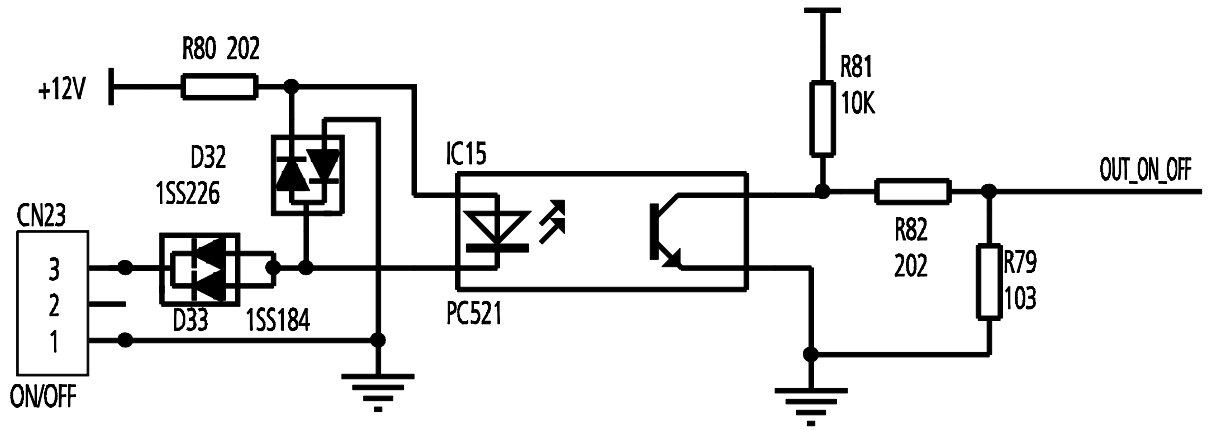

B For ALARM terminal port CN33

1. Provide the terminal port to connect ALARM, but no voltage of the terminal port , the power from the ALARM system (not from the unit)
2. Although design voltage can support higher voltage, but we strongly ask you connect the power less than 24V, current less than 0.5A
3. When the unit occurs the problem, the relay would be closed, then ALARM works

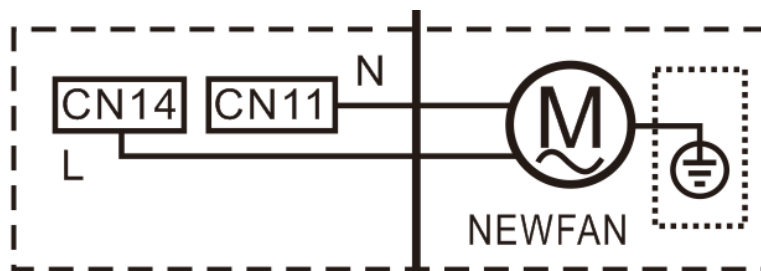
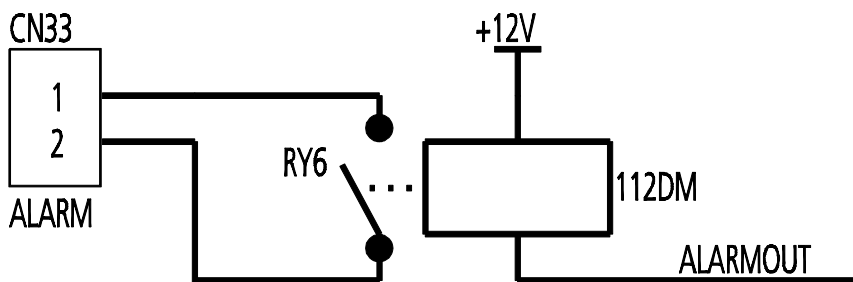

C. For new fresh motor terminal port CN14&CN14

1. Connect the fan motor to the port, no need care L/N of the motor;
2. The output voltage is the power supply;
3. The fresh motor cannot exceed 200W or 1A, follow the smaller one;
4. The new fresh motor will be worked when the indoor fan motor work ;when the indoor fan motor stops, the new fresh motor would be stopped;
5. When the unit enter force cooling mode or capacity testing mode, the fresh motor isn't work.

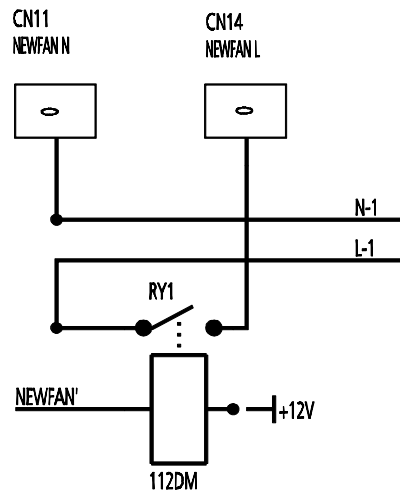

MTIU-09HWFN1-M, MTIU-12HWFN1-M, MTIU-18HWFN1-M, MTIU-24HWFN1-M, MTI-36HWFN1-M ,
 MTI-48HWFN1-M, MHG-60HWFN1-MW

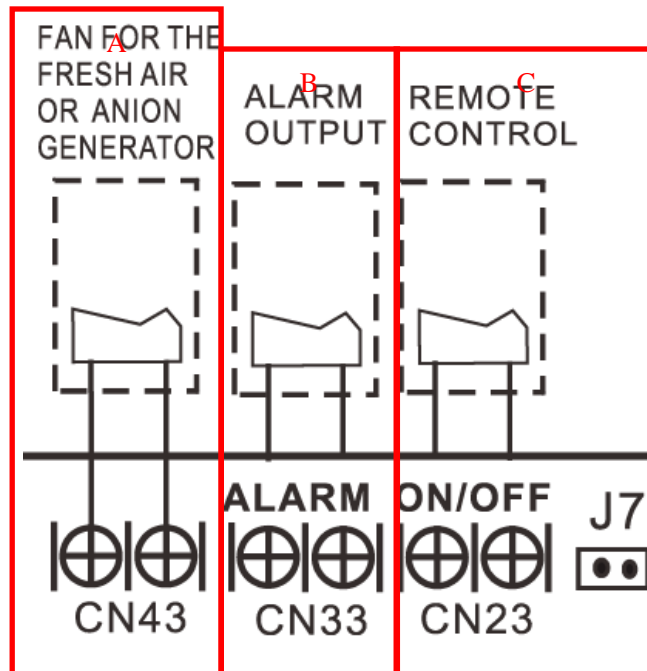

A. For new fresh motor terminal port (also for Anion generator) CN43:

1. Connect the fan motor to the port, no need care L/N of the motor;
2. The output voltage is the power supply;
3. The fresh motor cannot excess 200W or 1A, follow the smaller one;
4. The new fresh motor will be worked when the indoor fan motor work; when the indoor fan motor stops, the new fresh motor would be stopped;
5. When the unit enter force cooling mode or capacity testing mode, the fresh motor isn't work.

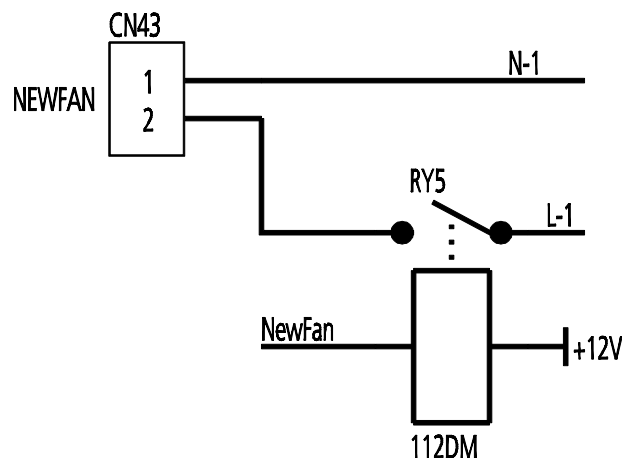

B For ALARM terminal port CN33

1. Provide the terminal port to connect ALARM, but no voltage of the terminal port, the power from the ALARM system (not from the unit)
2. Although design voltage can support higher voltage, but we strongly ask you connect the power less than 24V, current less than 0.5A
3. When the unit occurs the problem, the relay would be closed, then ALARM works

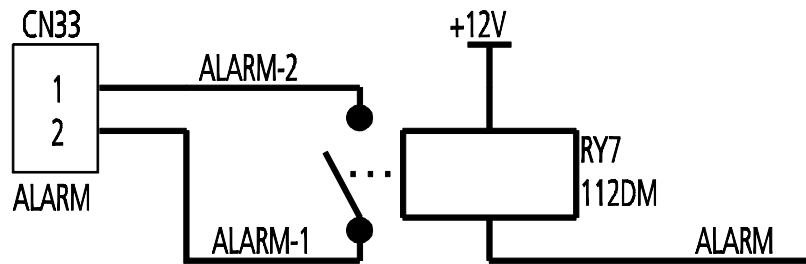

C. For remote control (ON-OFF) terminal port CN23 and short connector of J7

1. Remove the short connector of J7 when you use ON-OFF function;
2. When remote switch off (OPEN), the unit would be off;
3. When remote switch on (CLOSE), the unit would be on;
4. When close/open the remote switch, the unit would be responded the demand within 2 seconds;
5. When the remote switch on. You can use remote controller/wire controller to select the mode what you want; when the remote switch off, the unit would not respond the demand from remote controller/wire controller.

When the remote switch off, but the remote controller / wire controller are on, CP code would be shown on the display board.

6. The voltage of the port is 12V DC, design Max. current is 5mA.

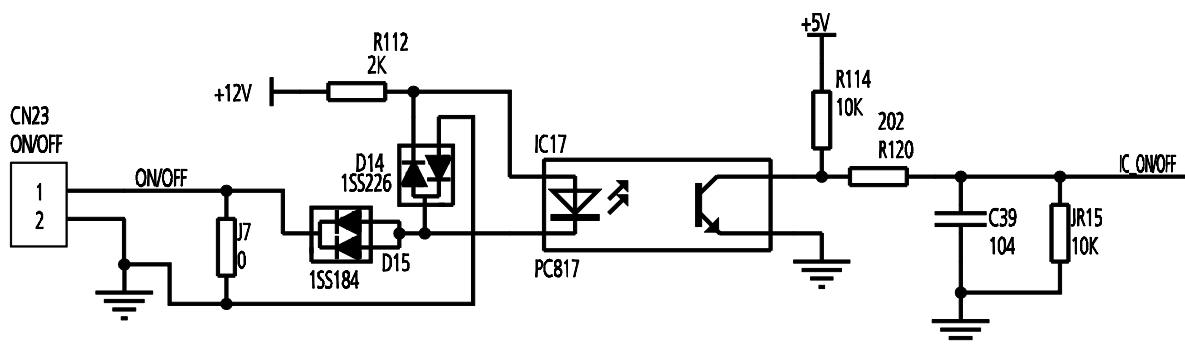

6.1.2 Micro-Switch Introduce:

CCA3U-09HRFN1-M(C), CCA3U-12HRFN1-M(C), CCA3U-18HRFN1-M(C),MCD-24HRFN1-M(C)

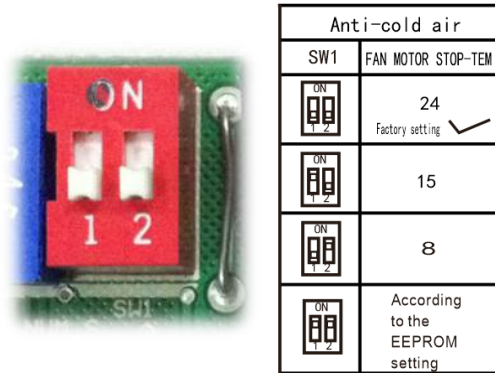

A. Micro-switch SW1 is for selection of indoor fan stop temperature (TEL0) when it is in anti-cold wind action in heating mode.

Range: 24°C, 15°C, 8°C, according to EEROM setting (reserved for special customizing).

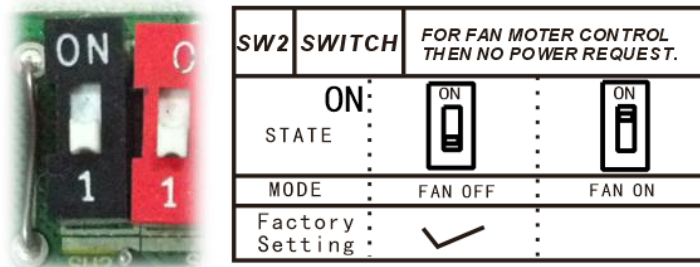
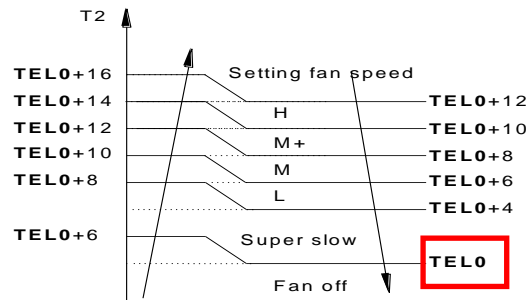

B. Micro-switch SW2 is for selection of indoor FAN ACTION if room temperature reaches the setpoint and the compressor stops.

Range: OFF (in 127s), Keep running.

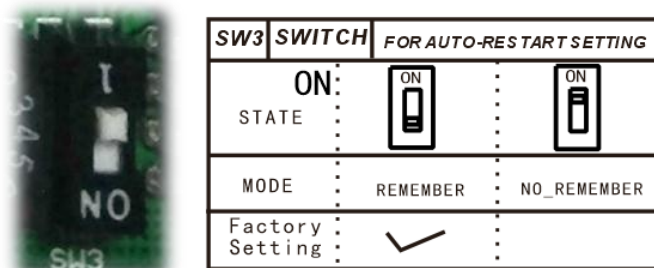

C. Micro-switch SW3 is for selection of auto-restart function.

Range: Active, inactive

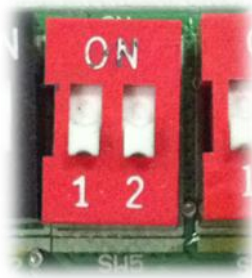

SW5	SWITCH	FOR MODE-PRIOR SETTING			
ON:					
STATE		ON	ON	ON	ON
MODE		HEAT	HEAT	COOL	COOL
Factory Setting		✓			

D. Micro-switch SW5 is for setting mode priority of multi connection.

Range: Heat, cool.



SW6	SWITCH	FOR TEMP. COMPENSATION			
ON:					
STATE		ON	ON	ON	ON
VALUE		6	4	2	E function
Factory Setting		✓			

E. Micro-switch SW6 is for selection of temperature compensation in heating mode. This helps to reduce the real temperature difference between ceiling and floor so that the unit could run properly. If the height of installation is lower, smaller value could be chosen.

Range: 6°C, 4°C, 2°C, E function (reserved for special customizing)

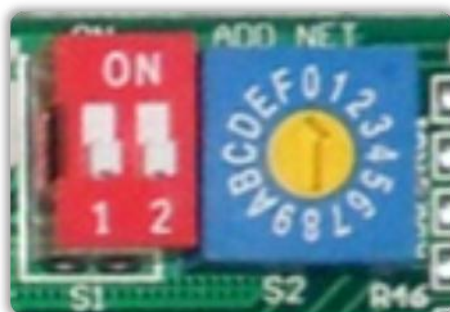





SWITCH		FOR CCM UNIT ADDRESS	
S2 + S1			
ADDRESS	0~15		16~31
Factory Setting	✓		
S2 + S1			
ADDRESS	32~47		48~63
Factory Setting			

F. Micro-switch S1 and dial-switch S2 are for address setting when you want to control this unit by a central controller.

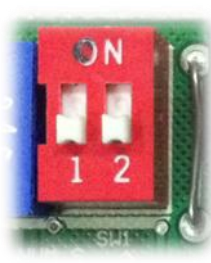
Range: 00-63



CTBU-09HWFN1-M(C), CTBU-12HWFN1-M(C), CTBU-18HWFN1-M(C),CTBU-24HWFN1-M(C), CTBU-36HWFN1-M(C), CTBU-48HWFN1-M(C)



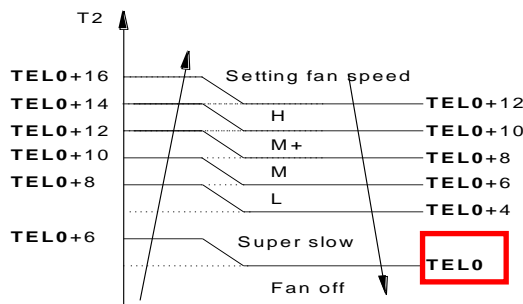

FOR ANTI-COLD WIND				
SW1				
TELO	24°C	15°C	Fan motor do not stop.	According to the E Function.
FACTORY SETTING	✓			

A. Micro-switch SW1 is for selection of indoor fan stop temperature (TELO) when it is in anti-cold wind action in heating mode.

Range: 24°C, 15°C, Fan motor do not stop, According to EEROM setting (reserved for special customizing).





SW2	SWITCH	FOR FAN MOTER CONTROL THEN NO POWER REQUEST.	
ON STATE			
MODE	FAN OFF	FAN ON	
Factory Setting			✓

B. Micro-switch SW2 is for selection of indoor FAN ACTION if room temperature reaches the setpoint and the compressor stops.

Range: OFF (in 127s), Keep running.



FOR SETTING AUTO-RESTART		
SW3		
AUTO-RESTART	ACTIVE	INACTIVE
FACTORY SETTING	✓	

C. Micro-switch SW3 is for selection of auto-restart function.

Range: Active, inactive



SW5		
MODE	HEATING PRIORITY	COOLING PRIORITY
FACTORY SETTING	<input checked="" type="checkbox"/>	

D. Micro-switch SW5 is for setting mode priority of multi connection.(Only for CTBU-09HWFN1-M(C), , CTBU-12HWFN1-M(C), CTBU-18HWFN1-M(C),CTBU-24HWFN1-M(C))

Range: Heat, cool.



FOR TEMP. COMPENSATION(HEATING)				
SW6				
CODE	6°C	2°C	4°C	EEPROM DEFAULT
FACTORY SETTING	<input checked="" type="checkbox"/>			

E. Micro-switch SW6 is for selection of temperature compensation in heating mode. This helps to reduce the real temperature difference between ceiling and floor so that the unit could run properly. If the height of installation is lower, smaller value could be chosen.

Range: 6°C, 2°C, 4°C, E function (reserved for special customizing)

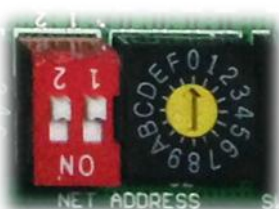

FOR SETTING NETADDRESS				
S1+S2				
CODE	0~F	0~F	0~F	0~F
NETADDRESS	0~15	16~31	32~47	48~63
FACTORY SETTING	<input checked="" type="checkbox"/>			

F. Micro-switch S1 and dial-switch S2 are for address setting when you want to control this unit by a central controller.







Range: 00-63

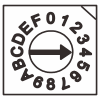

FOR SETTING STATIC PRESSURE							
ENC2						STATIC PRESSURE RANGE(Pa)	
MODEL (K Btu/h)	CODE	0	1	2	3	4	
	MODEL ≤ 12	0(Pa)	10(Pa)	20(Pa)	30(Pa)	40(Pa)	0-45(Pa)
	12 < MODEL ≤ 24	10(Pa)	25(Pa)	40(Pa)	55(Pa)	70(Pa)	0-100(Pa)
	24 < MODEL ≤ 60	20(Pa)	35(Pa)	50(Pa)	65(Pa)	80(Pa)	0-100(Pa)
	FACTORY SETTING	<input checked="" type="checkbox"/>					

G. Dial-switch ENC2 is for adjusting the fan motor to suit different ducts with different pressure drop. You can set it according to the fan curve.



FOR SETTING POWER(FACTORY USE ONLY)						
ENC1						
CODE	4	5	7	8	9	A B
POWER	≤53	54~71	72~90	91~105	106~140	141~160 ≥161
FACTORY SETTING	ACCORDING TO RELATED MODEL.					

H. Dial-switch ENC1(Only for CTBU-36HWFN1-M(C), CTBU-48HWFN1-M(C)): The indoor PCB is universal designed for whole series units from 18K to 55K. This ENC1 setting will tell the main program what size the unit is.

NOTE: Usually there is glue on it because the switch position cannot be changed at random unless you want to use this PCB as a spare part to use in another unit. Then you have to select the right position to match the size of the unit.

“53” means 5.3kW (18K),“105” means 10.5kW(36K), and so on.

CFAU-09HRFN1-M(C), CFAU-12HRFN1-M(C)



For Setting Auto-Restart		
SW1		
Mode	ACTIVE	INACTIVE
Factory Setting	✓	

A. Micro-switch SW1 is for selection of auto-restart function.

Range: Active, inactive.



For Setting Down louver		
SW101		
Mode	INACTIVE	ACTIVE
Factory Setting	✓	

B. Take off the panel, you can see the switch SW101 which is used for selecting both air outlets or upper air outlet only.



FOR TEMP. COMPENSATION(HEATING)				
SW102				
Mode	According to E Function (0°C)	2°C	4°C	-2°C
Factory Setting	✓			

C. Micro-switch SW102 is for selection of temperature compensation in heating mode. This helps to reduce the real temperature difference between ceiling and floor so that the unit could run properly. If the unit is on-floor installed, 0 should be chosen.

Range: E function (reserved for special customizing) /0°C, 2°C, 4°C, -2°C







For Setting Fan Motor Control then No Power Request				
SW103				
Mode	FAN OFF	LOW FAN SPEED	SETTING FAN SPEED	TERMAL
Factory Setting		✓		

D. Micro-switch SW103 is for selection of indoor FAN ACTION if room temperature reaches the setpoint and the compressor stops.

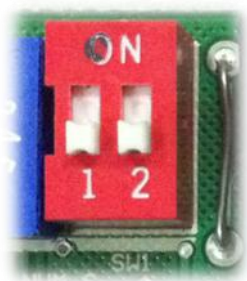
Range: OFF (in 127s), Low Speed, Setting Speed, Termal (runs for 1 minute ever 4-minute stop).



MCD-36HRFN1-M(C), MCD-48HRFN1-M(D)



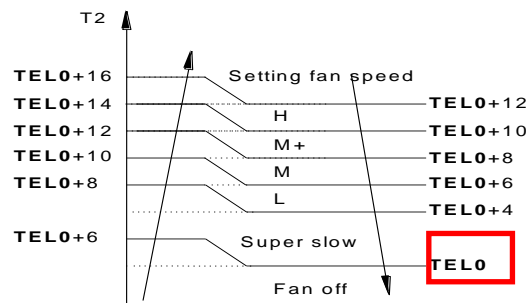

Anti-cold air	
SW1	FAN MOTOR STOP-TEM
	24 Factory setting ✓
	15
	8
	According to the EEPROM setting

A. Micro-switch SW1 is for selection of indoor fan stop temperature (TELO) when it is in anti-cold wind action in heating mode.

Range: 24°C, 15°C, 8°C, according to EEROM setting (reserved for special customizing).





SW2	SWITCH	FOR FAN MOTER CONTROL THEN NO POWER REQUEST.	
ON	STATE		
	MODE	FAN OFF	FAN ON
	Factory Setting		✓

B. Micro-switch SW2 is for selection of indoor FAN ACTION if room temperature reaches the setpoint and the compressor stops.

Range: OFF (in 127s), Keep running.



SW3	SWITCH	FOR AUTO-RESTART SETTING	
ON	STATE		
	MODE	REMEMBER	NO_REMEMBER
	Factory Setting	✓	

C. Micro-switch SW3 is for selection of auto-restart function.

Range: Active, inactive

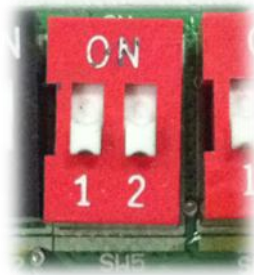

SW5 SWITCH		FOR MAIN-SLAVE SETTING			
ON:					
STATE					
MODE		MAIN NO SLAVE	MAIN	MAIN	SLAVE
Factory Setting		✓			

D. Micro-switch SW5 is for setting the master or slave unit when the unit is in twin connection.

Range: Master no slave (Normal 1 drive 1 connection), Master (2 positions without difference), Slave



SW6 SWITCH		FOR TEMP. COMPENSATION			
ON:					
STATE					
VALUE		6	4	2	E function
Factory Setting		✓			

E. Micro-switch SW6 is for selection of temperature compensation in heating mode. This helps to reduce the real temperature difference between ceiling and floor so that the unit could run properly. If the height of installation is lower, smaller value could be chosen.

Range: 6°C, 4°C, 2°C, E function (reserved for special customizing)



SWITCH		FOR CCM UNIT ADDRESS			
S2 + S1					
ADDRESS		0~15		16~31	
Factory Setting		✓			
S2 + S1					
ADDRESS		32~47		48~63	
Factory Setting					

F. Micro-switch S1 and dial-switch S2 are for address setting when you want to control this unit by a central controller.

Range: 00-63



ENC1	SWITCH	(FOR POWER)
	NUMBER	POWER
	4	4000W-5300W (2.0HP)
	5	5400W-7100W (2.5HP)
	6	/
	7	7500W-9000W (3.2HP)
	8	9100W-10500W (4.0HP)
	9	12000W-14000W (5.0HP)
	A	14500W-16000W (6.0HP)

G. Dial-switch ENC1: The indoor PCB is universal designed for whole series units from 18K to 55K. This ENC1 setting will tell the main program what size the unit is.

NOTE: Usually there is glue on it because the switch position cannot be changed at random unless you want to use this PCB as a spare part to use in another unit. Then you have to select the right position to match the size of the unit.

MUEU-18HRFN1-M(C), MUEU-24HRFN1-M(C)

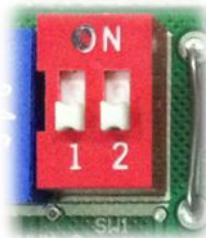

FOR ANTI-COLD WIND				
SW1				
TELO	24°C	15°C	8°C	According to E Function.
FACTORY SETTING	✓			

A. Micro-switch SW1 is for selection of indoor fan stop temperature (TELO) when it is in anti-cold wind action in heating mode.

Range: 24°C, 15°C, 8°C, According to EEROM setting (reserved for special customizing).

For MUEU-24HRFN1-M(C):

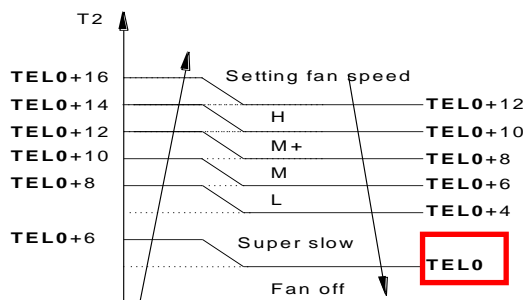

For MUEU-18HRFN1-M(C):

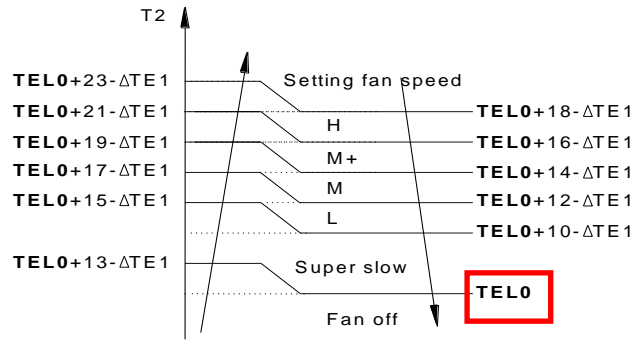

SW2		
FAN MOTOR CONTROL THEN NO POWER REQUEST	FAN OFF	FAN ON
FACTORY SETTING		✓

B. Micro-switch SW2 is for selection of indoor FAN ACTION if room temperature reaches the setpoint and the compressor stops.

Range: OFF (in 127s), Keep running.



FOR SETTING AUTO-RESTART		
SW3		
AUTO-RESTART	ACTIVE	INACTIVE
FACTORY SETTING	✓	

C. Micro-switch SW3 is for selection of auto-restart function.

Range: Active, inactive



SW5		
MODE	HEATING PRIORITY	COOLING PRIORITY
FACTORY SETTING	✓	

D. Micro-switch SW5 is for setting mode priority of multi connection.

Range: Heat, cool.

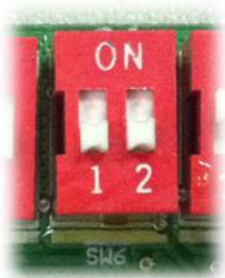

FOR SETTING TEMP. COMPENSATION(HEATING)				
SW6				
CODE	0°C	2°C	4°C	According to E function
FACTORY SETTING	✓			

E. Micro-switch SW6 is for selection of temperature compensation in heating mode. This helps to reduce the real temperature difference between ceiling and floor so that the unit could run properly. If the unit is on-floor installed, 0 should be chosen.

Range: 0°C, 2°C, 4°C, E function (reserved for special customizing)

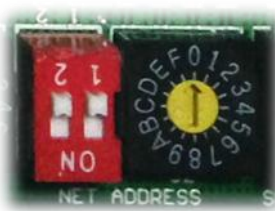

FOR SETTING NETADDRESS				
S1+S2				
CODE	0~F	0~F	0~F	0~F
NETADDRESS	0~15	16~31	32~47	48~63
FACTORY SETTING	✓			

F. Micro-switch S1 and dial-switch S2 are for address setting when you want to control this unit by a central controller.

Range: 00-63

MUE-36HRFN1-M(C), MUE-48HRFN1-M(C)

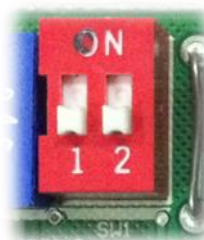

FOR ANTI-COLD WIND				
SW1				
TELO	24°C	15°C	Fan motor do not stop.	According to the EFunction.
FACTORY SETTING	✓			

A. Micro-switch SW1 is for selection of indoor fan stop temperature (TELO) when it is in anti-cold wind action in heating mode.

Range: 24°C, 15°C, Fan motor do not stop, According to EEROM setting (reserved for special customizing).

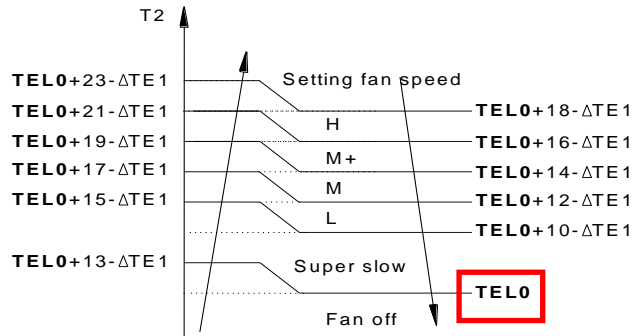

FOR SETTING FAN MOTOR CONTROL WHEN THERE IS NO DEMAND		
SW2		
MODE	FAN OFF	FAN ON
FACTORY SETTING	<input checked="" type="checkbox"/>	<input type="checkbox"/>

B. Micro-switch SW2 is for selection of indoor FAN ACTION if room temperature reaches the setpoint and the compressor stops.

Range: OFF (in 127s), Keep running.



FOR SETTING AUTO-RESTART		
SW3		
AUTO-RESTART	ACTIVE	INACTIVE
FACTORY SETTING	<input checked="" type="checkbox"/>	<input type="checkbox"/>

C. Micro-switch SW3 is for selection of auto-restart function.

Range: Active, inactive



For Setting Fan Quantity		
SW4		
Mode	Single Fan	Double Fan
Factory Setting	<input type="checkbox"/>	<input checked="" type="checkbox"/>

D. Micro-switch SW4 is for selection of quantity of fan motors. Same as size selection switch, this switch is for making the PCB suitable for all series units. DO NOT change it at random unless you want to use the PCB as a spare part

Range: Single Fan, Double Fan



For temp. compensation				
SW6				
CEILING AND FLOOR TYPE	0°C	2°C	4°C	According to E Function
For Setting CEILING TYPE or FLOOR TYPE	FLOOR TYPE	CEILING TYPE		
Factory Setting	✓			

E. Micro-switch SW6 is for selection of temperature compensation in heating mode. This helps to reduce the real temperature difference between ceiling and floor so that the unit could run properly. If the unit is on-floor installed, 0 should be chosen.

Range: 0°C, 2°C, 4°C, E function (reserved for special customizing)



FOR SETTING NETADDRESS				
S1+S2				
CODE	0~F	0~F	0~F	0~F
NETADDRESS	0~15	16~31	32~47	48~63
FACTORY SETTING	✓			

F. Micro-switch S1 and dial-switch S2 are for address setting when you want to control this unit by a central controller.

Range: 00-63



FOR SETTING POWER (FACTORY USE ONLY)							
ENC1							
CODE	4	5	7	8	9	A	B
POWER	≤53	54~71	72~90	91~105	106~140	141~160	≥161
FACTORY SETTING	ACCORDING TO RELATED MODEL.						

G. Dial-switch ENC1: The indoor PCB is universal designed for whole series units from 18K to 55K. This ENC1 setting will tell the main program what size the unit is.

NOTE: Usually there is glue on it because the switch position cannot be changed at random unless you want to use this PCB as a spare part to use in another unit. Then you have to select the right position to match the size of the unit.

“53” means 5.3kW (18K), “105” means 10.5kW(36K), and so on.

MUE-60HRFN1-MW



FOR ANTI-COLD WIND				
SW1				
TELO	24°C	15°C	8°C	EEPROM DEFAULT
FACTORY SETTING	✓			

A. Micro-switch SW1 is for selection of indoor fan stop temperature (TELO) when it is in anti-cold wind action in heating mode.

Range: 24°C, 15°C, 8°C , According to EEROM setting (reserved for special customizing).

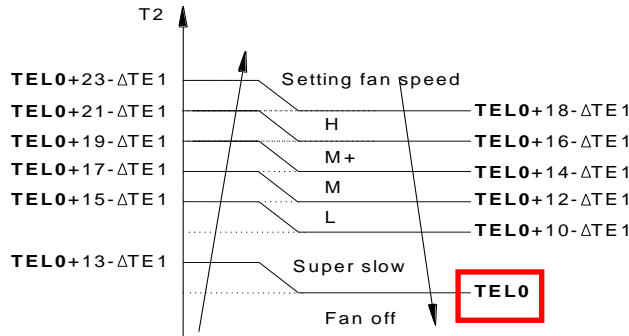

FOR SETTING AUTO-RESTART		
SW3		
AUTO-RESTART	ACTIVE	INACTIVE
FACTORY SETTING	✓	

B. Micro-switch SW3 is for selection of auto-restart function.

Range: Active, inactive



For Setting Fan Quantity		
SW4		
Mode	Single Fan	Double Fan
Factory Setting		✓

C. Micro-switch SW4 is for selection of quantity of fan motors. Same as size selection switch, this switch is for making the PCB suitable for all series units. DO NOT change it at random unless you want to use the PCB as a spare part

Range: Single fan, double fan



FOR TEMP. COMPENSATION(HEATING)				
SW6				
CODE	0°C	2°C	4°C	EEPROM default
FACTORY SETTING	✓			

D. Micro-switch SW6 is for selection of temperature compensation in heating mode. This helps to reduce the real temperature difference between ceiling and floor so that the unit could run properly. If the unit is on-floor installed, 0 should be chosen.

Range: 0°C, 2°C, 4°C, E function (reserved for special customizing)

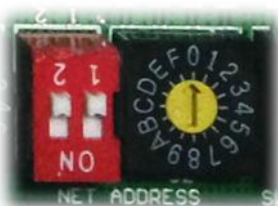

FOR SETTING NETADDRESS				
S1+S2				
CODE	0~F	0~F	0~F	0~F
NETADDRESS	0~15	16~31	32~47	48~63
FACTORY SETTING	✓			

E. Micro-switch S1 and dial-switch S2 are for address setting when you want to control this unit by a central controller.

Range: 00-63



FOR SETTING POWER(FACTORY USE ONLY)							
ENC1							
CODE	4	5	7	8	9	A	B
POWER	≤53	54~71	72~90	91~105	106~140	141~160	≥161
FACTORY SETTING	ACCORDING TO RELATED MODEL.						

F. Dial-switch ENC1: The indoor PCB is universal designed for whole series units from 18K to 55K. This ENC1 setting will tell the main program what size the unit is.

NOTE: Usually there is glue on it because the switch position cannot be changed at random unless you want to use this PCB as a spare part to use in another unit. Then you have to select the right position to match the size of the unit.

“53” means 5.3kW (18K), “105” means 10.5kW(36K), and so on.

MTIU-09HWFN1-M, MTIU-12HWFN1-M, MTIU-18HWFN1-M, MTIU-24HWFN1-M

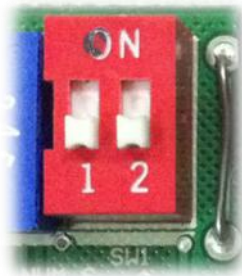

FOR ANTI-COLD WIND				
SW1				
TELO	24°C	15°C	8°C	EEPROM DEFAULT
FACTORY SETTING	✓			

A. Micro-switch SW1 is for selection of indoor fan stop temperature (TELO) when it is in anti-cold wind action in heating mode.

Range: 24°C, 15°C, 8°C, according to EEROM setting (reserved for special customizing).

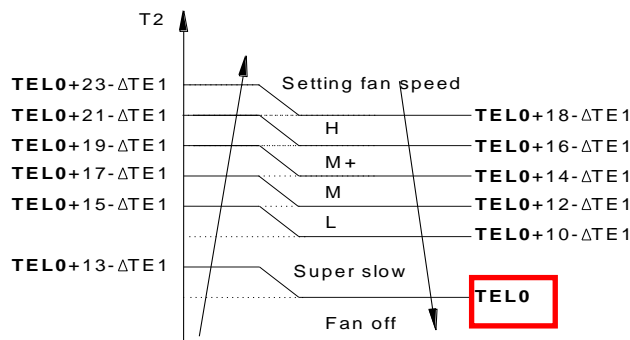

FOR SETTING AUTO-RESTART		
SW3		
MODE	AUTO-RESTART	NOT AUTO-RESTART
FACTORY SETTING	✓	

B. Micro-switch SW3 is for selection of auto-restart function.

Range: Active, inactive



FOR TEMP. COMPENSATION(HEATING)				
SW6				
CODE	6°C	2°C	4°C	EEPROM DEFAULT
FACTORY SETTING	✓			

C. Micro-switch SW6 is for selection of temperature compensation in heating mode. This helps to reduce the real temperature difference between ceiling and floor so that the unit could run properly. If the height

of installation is lower, smaller value could be chosen.

Range: 6°C, 4°C, 2°C, E function (reserved for special customizing)

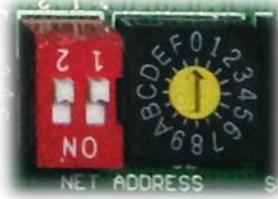

FOR SETTING NETADDRESS				
S1+S2				
CODE	0~F	0~F	0~F	0~F
NETADDRESS	0~15	16~31	32~47	48~63
FACTORY SETTING	<input checked="" type="checkbox"/>			

D. Micro-switch S1 and dial-switch S2 are for address setting when you want to control this unit by a central controller.

Range: 00-63

MTI-36HWFN1-M , MTI-48HWFN1-M, MHG-60HWFN1-MW

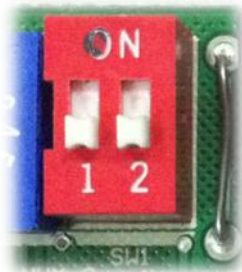

FOR ANTI-COLD WIND				
SW1				
TELO	24°C	15°C	8°C	EEPROM DEFAULT
FACTORY SETTING	<input checked="" type="checkbox"/>			

A. Micro-switch SW1 is for selection of indoor fan stop temperature (TELO) when it is in anti-cold wind action in heating mode.

Range: 24°C, 15°C, 8°C, according to EEROM setting (reserved for special customizing).

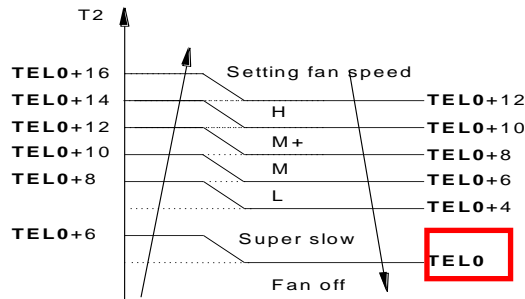



FOR SETTING AUTO-RESTART		
SW3		
MODE	AUTO-RESTART	NOT AUTO-RESTART
FACTORY SETTING	<input checked="" type="checkbox"/>	

B. Micro-switch SW3 is for selection of auto-restart function.

Range: Active, inactive

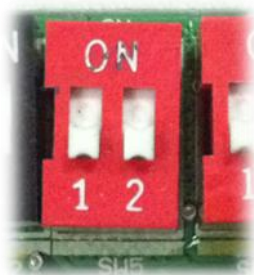

FOR MAIN-SLAVE SETTING				
SW5				
MODE	MAIN NO SLAVE	MAIN	MAIN	SLAVE
FACTORY SETTING	<input checked="" type="checkbox"/>			

C. Micro-switch SW5 is for setting the master or slave unit when the unit is in twin connection.

Range: Master no slave (Normal 1 drive 1 connection), Master (2 positions without difference), Slave



FOR TEMP. COMPENSATION(HEATING)				
SW6				
CODE	6°C	2°C	4°C	EEPROM DEFAULT
FACTORY SETTING	<input checked="" type="checkbox"/>			

D. Micro-switch SW6 is for selection of temperature compensation in heating mode. This helps to reduce the real temperature difference between ceiling and floor so that the unit could run properly. If the height of installation is lower, smaller value could be chosen.

Range: 6°C, 4°C, 2°C, E function (reserved for special customizing)

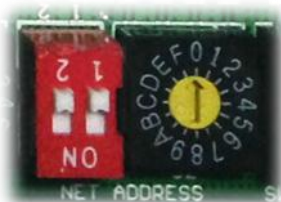

FOR SETTING NETADDRESS				
S1+S2				
CODE	0~F	0~F	0~F	0~F
NETADDRESS	0~15	16~31	32~47	48~63
FACTORY SETTING	✓			

E. Micro-switch S1 and dial-switch S2 are for address setting when you want to control this unit by a central controller.

Range: 00-63



FOR SETTING POWER(FACTORY USE ONLY)							
ENC1							
CODE	4	5	7	8	9	A	B
POWER	≤53	54~71	72~90	91~105	106~140	141~160	≥161
FACTORY SETTING	ACCORDING TO RELATED MODEL.						

F. Dial-switch ENC1: The indoor PCB is universal designed for whole series units from 18K to 55K. This ENC1 setting will tell the main program what size the unit is.

NOTE: Usually there is glue on it because the switch position cannot be changed at random unless you want to use this PCB as a spare part to use in another unit. Then you have to select the right position to match the size of the unit.

“53” means 5.3kW (18K), “105” means 10.5kW(36K), and so on.

6.2 Outdoor Unit

**MOB30-09HFN1-MX0W, MOB01-09HFN1-MW0W, MOB30-12HFN1-MV0W, MOB01-12HFN1-MV0W,
MOCA30-18HFN1-MT0W, MOCA01-18HFN1-MT0W, MOCA31-18HFN1-MT0W,
MOD31-24HFN1-MT0W**

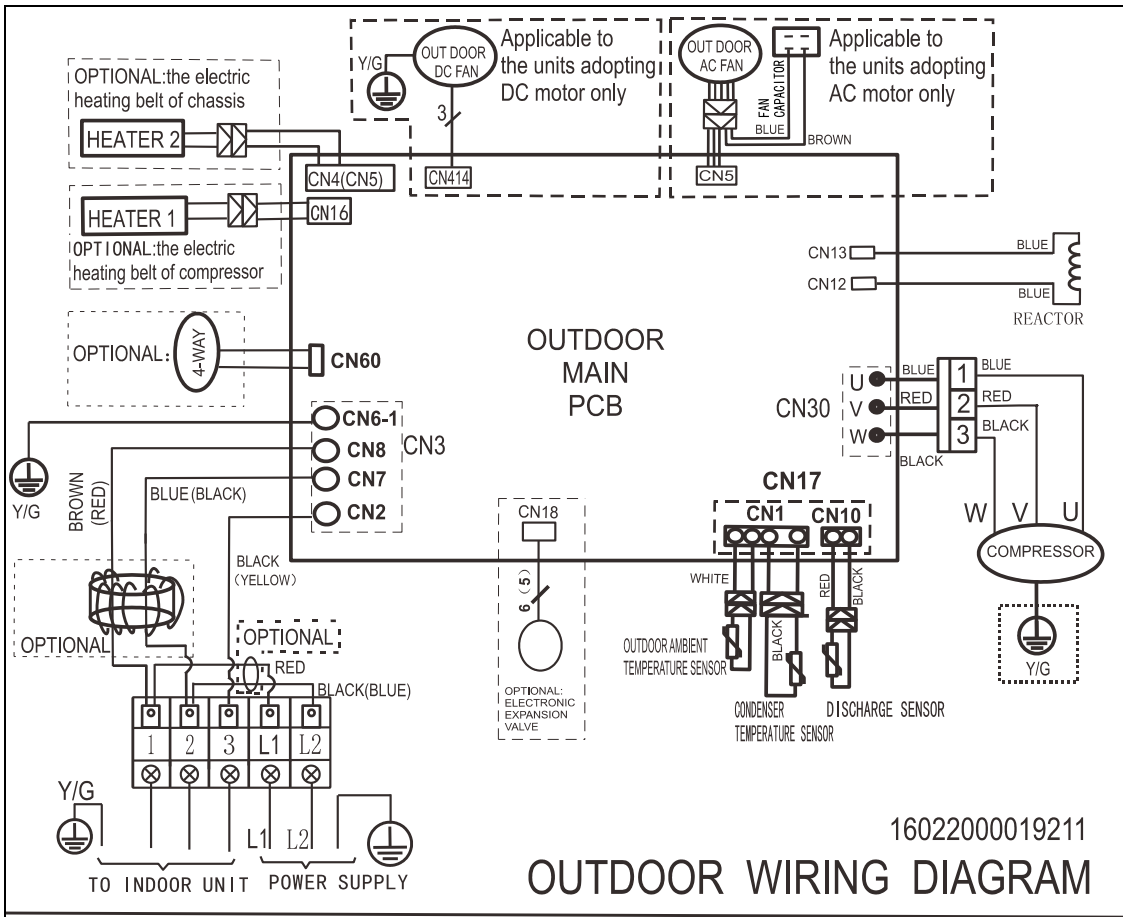

MOBA30-09HFN1-MT0W, MOB30-12HFN1-MT0W

Notes: - - - - -

This symbol indicates the element is optional, the actual shape shall prevail.

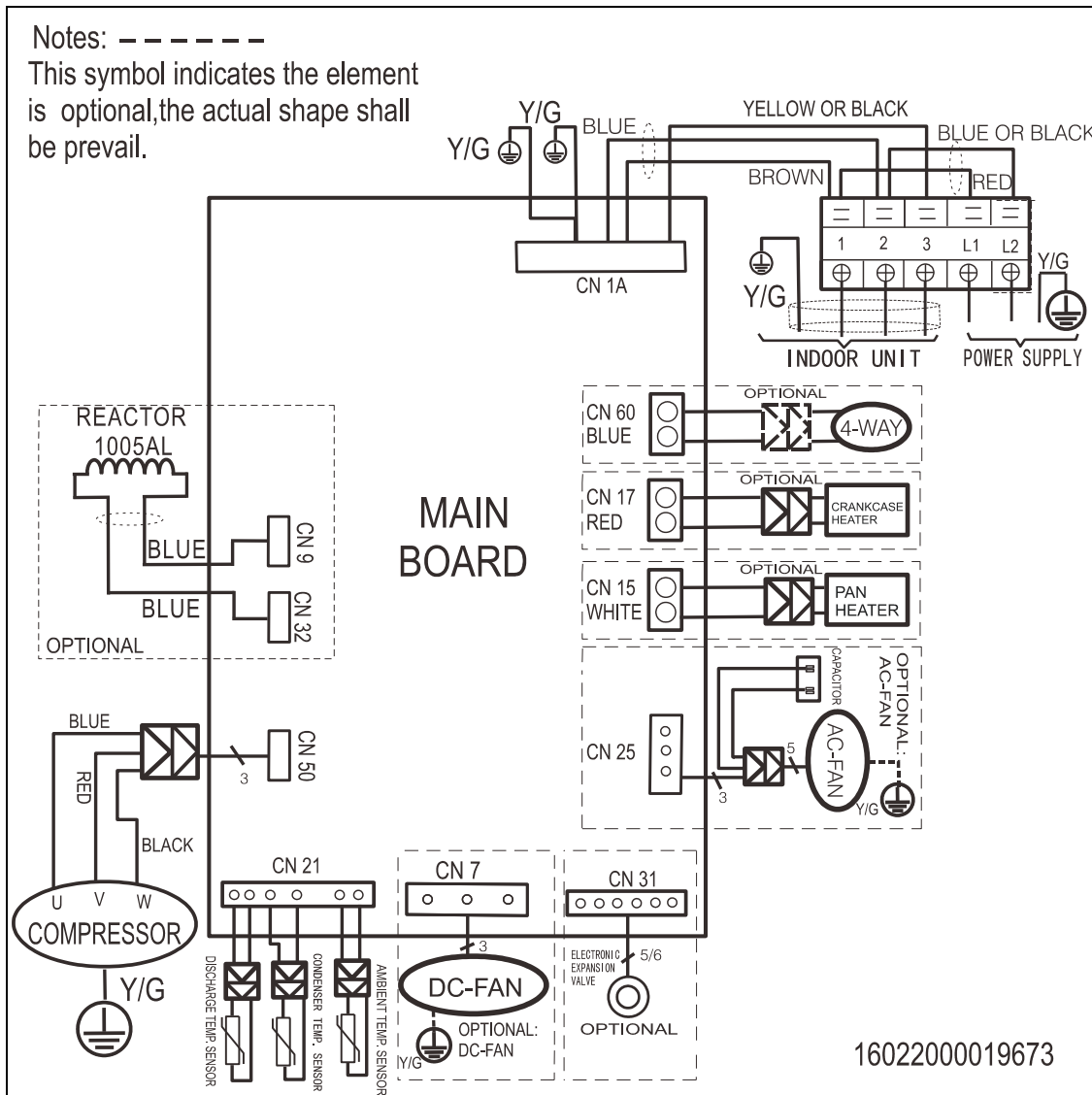

MOD30-24HFN1-MT0W, MOD01-23HFN1-MT0W

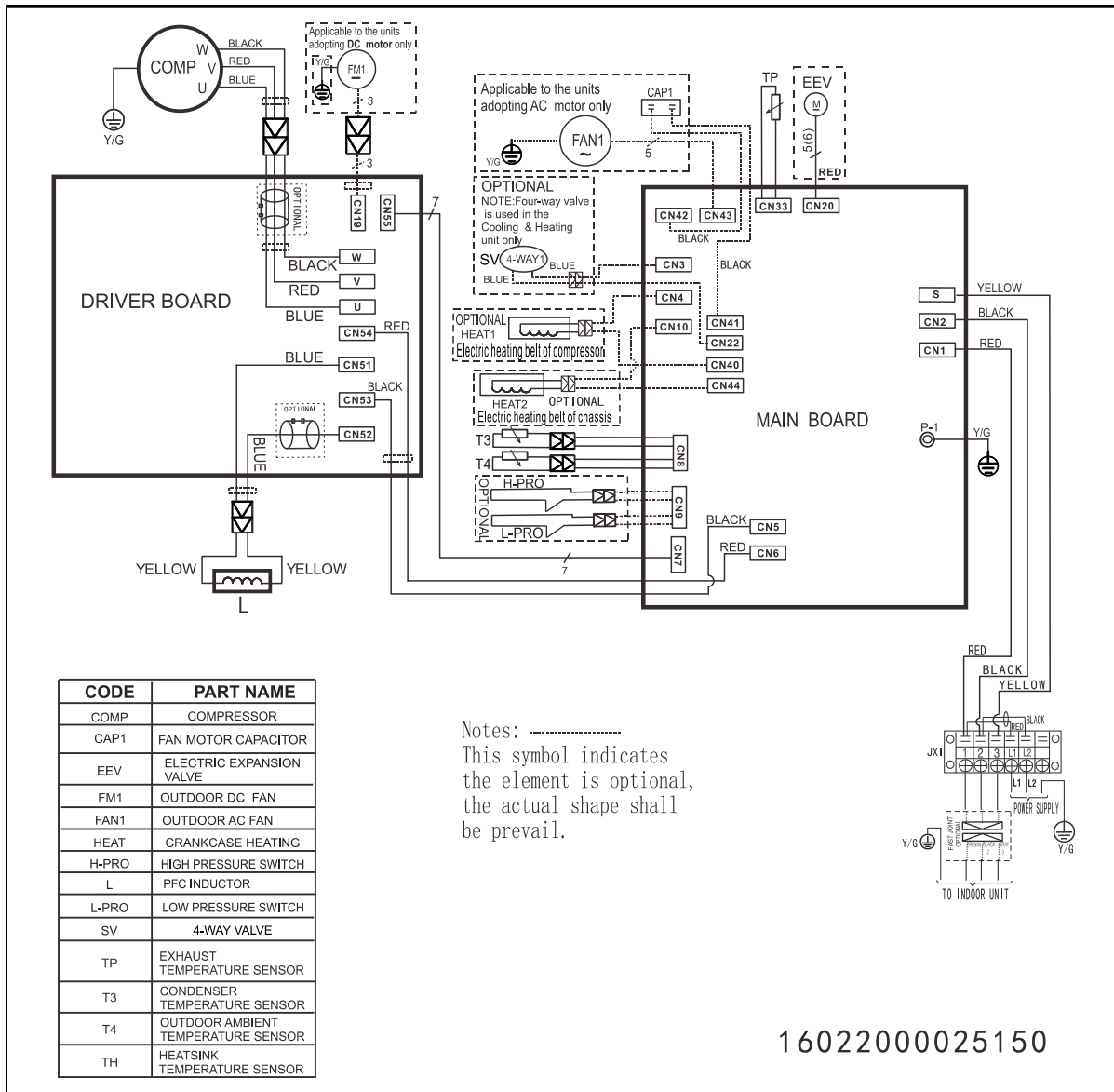

MOD30U-36HFN1-M

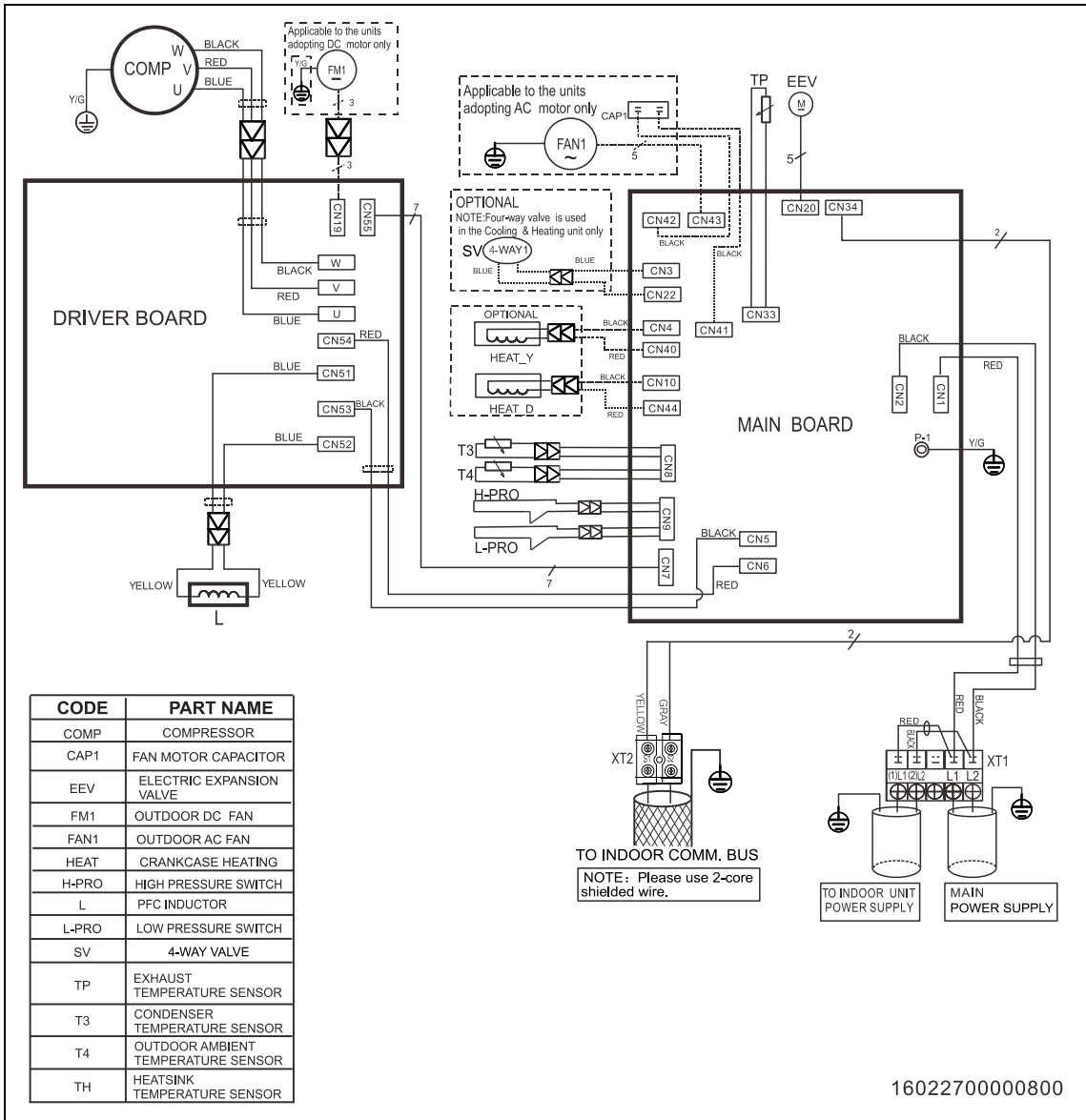

1602270000800

MOE30U-48HFN1-M, MOE30U-60HFN1-M

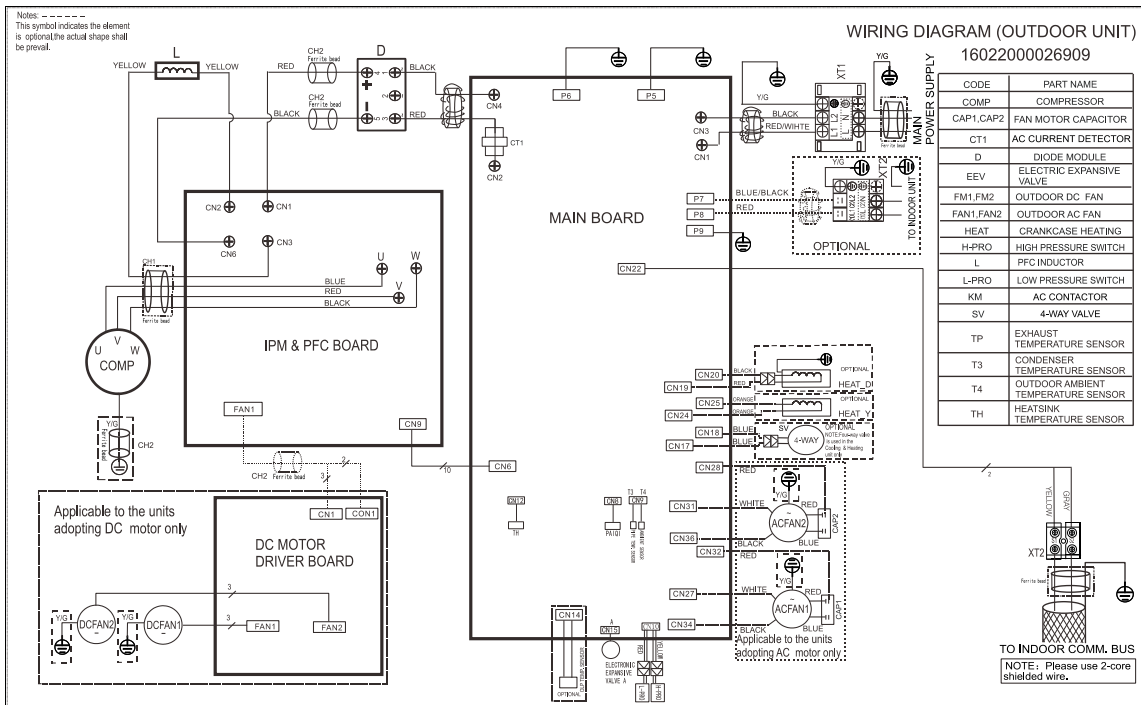

PCB board of MOB30-09HFN1-MX0W, MOB30-12HFN1-MV0W, MOCA30-18HFN1-MT0W, MOB01-09HFN1-MW0W, MOB01-12HFN1-MV0W, MOCA01-18HFN1-MT0W, MOCA31-18HFN1-MT0W, MOD31-24HFN1-MT0W

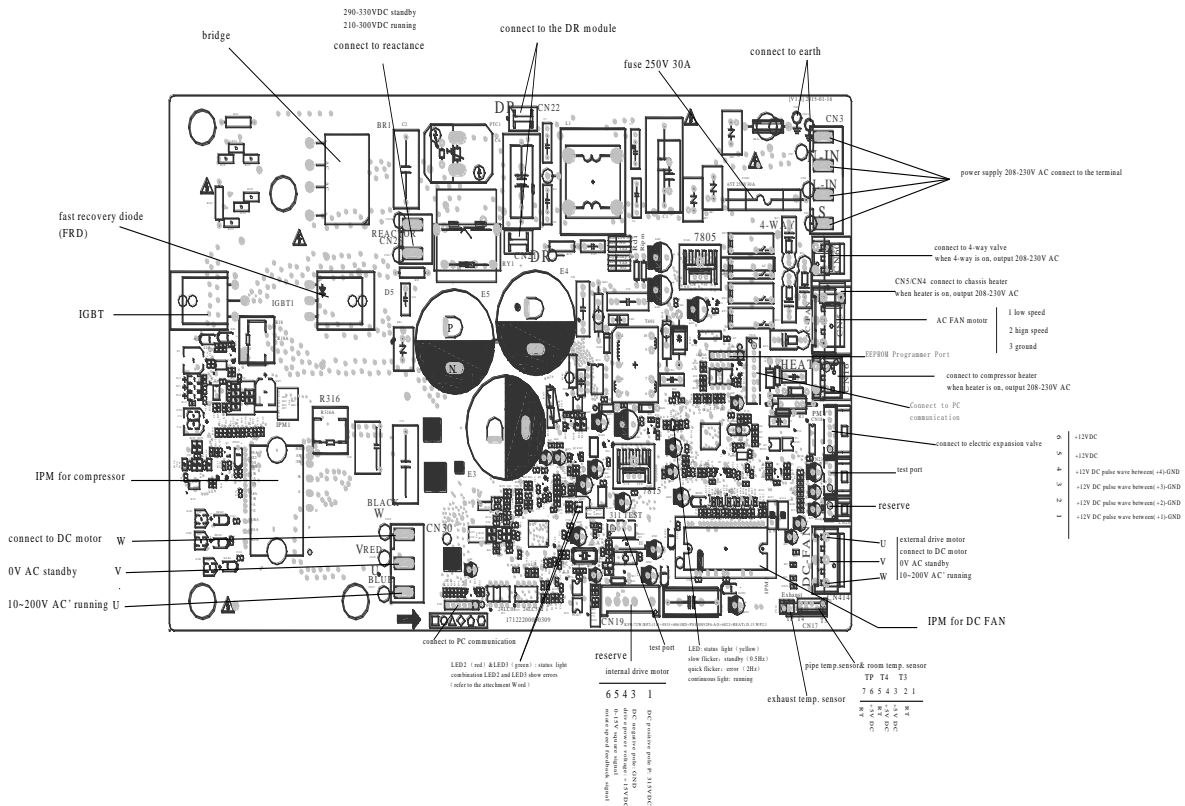

For MOD30-24HFN1-MT0W, MOD01-23HFN1-MT0W, MOD30U-36HFN1-M

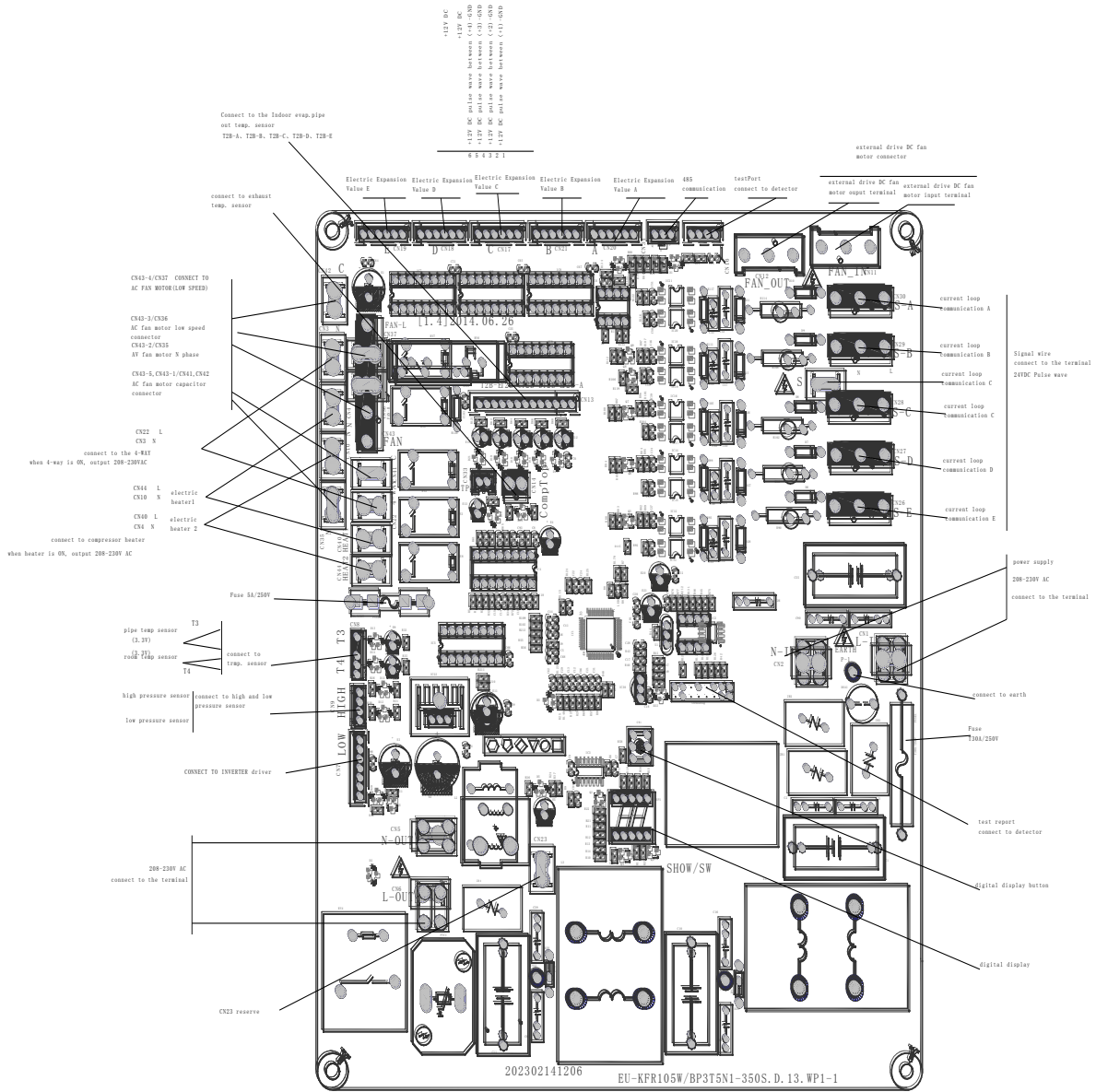

For MOBA30-09HFN1-MT0W, MOB30-12HFN1-MT0W

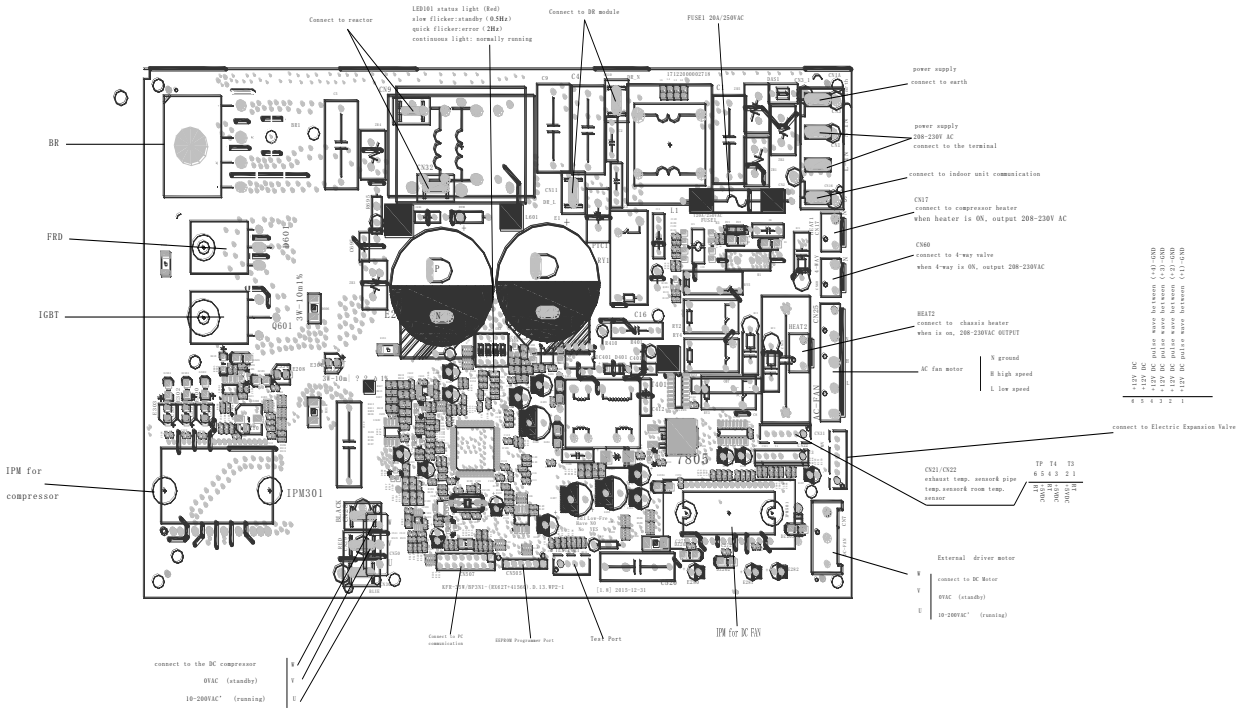

For MOE30U-48HFN1-M, MOE30U-60HFN1-M

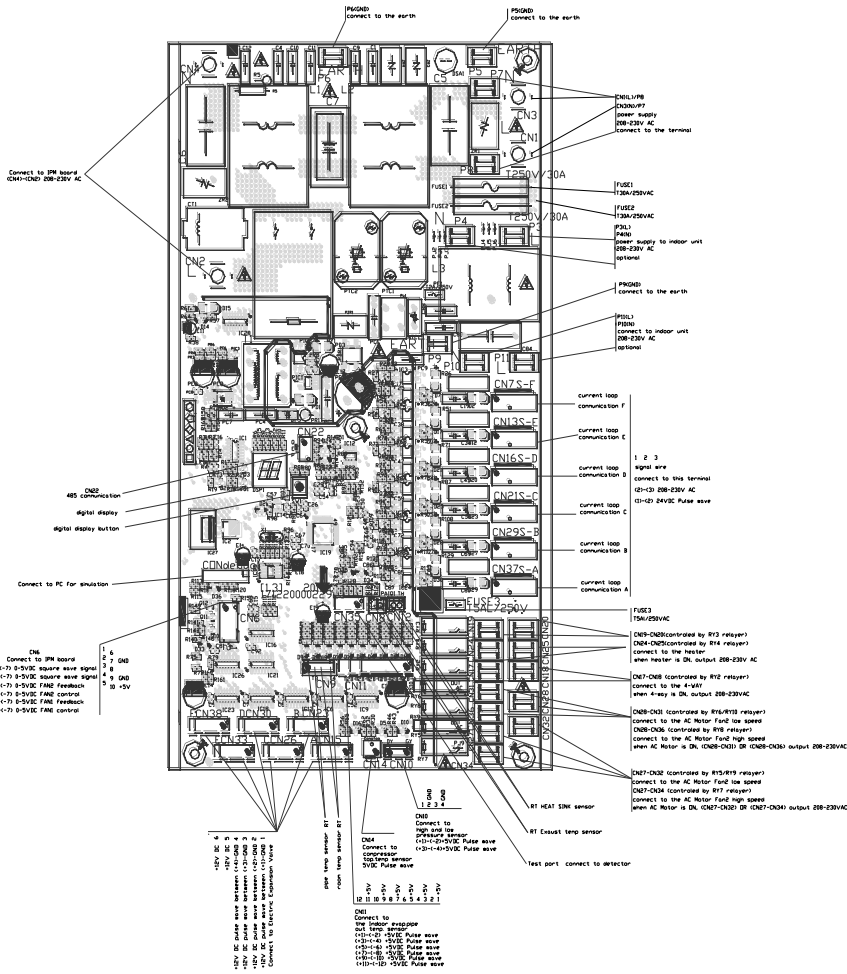

IPM board of MOD30-24HFN1-MT0W, MOD01-23HFN1-MT0W, MOD30U-36HFN1-M

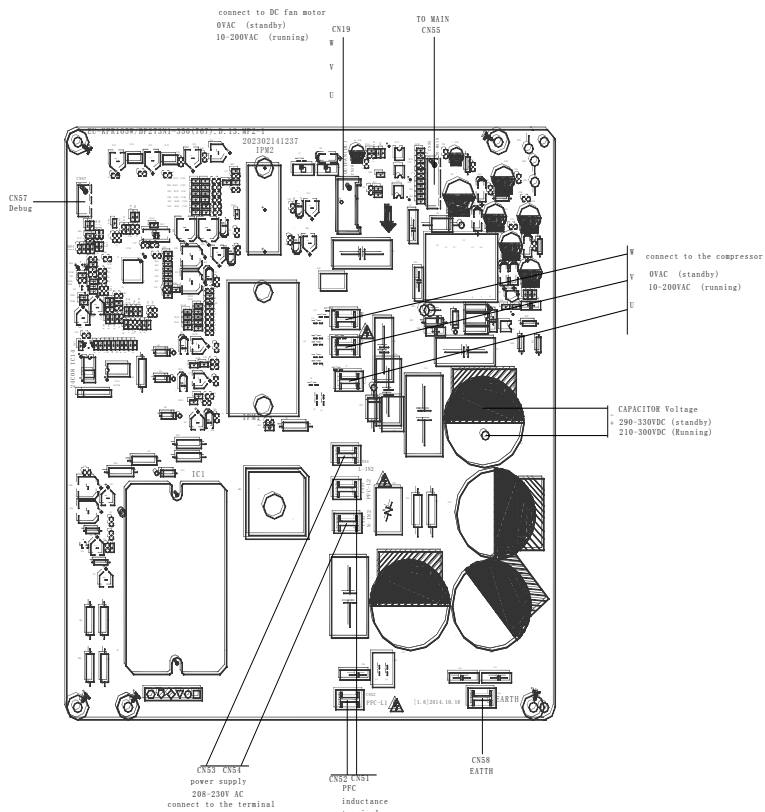

For MOE30U-48HFN1-M, MOE30U-60HFN1-M

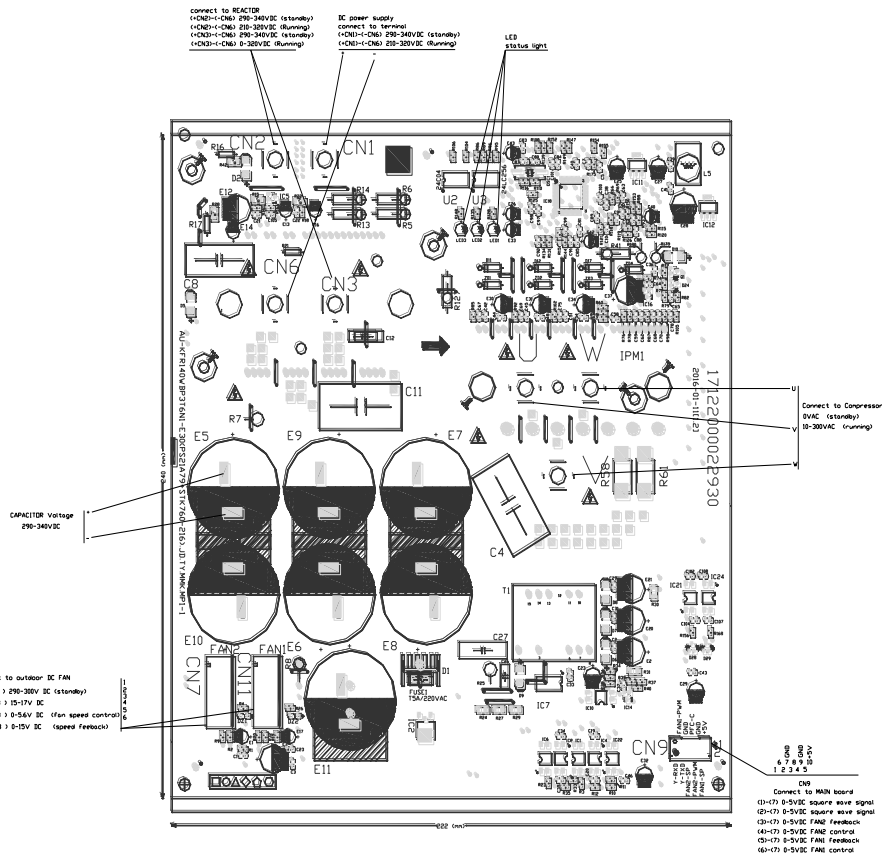

7. Fan Curves

ENC2							Static Pressure Range In. WG (Pa)
Model (K Btu/h)	Model	0	1	2	3	4	
	Model ≤ 12	0.02 (5)	0.04 (10)	0.08 (20)	0.12 (30)	0.16 (40)	0-0.18 (0-45)
	Model = 18	0.04 (10)	0.10 (25)	0.14 (35)	0.18 (45)	0.22 (55)	0-0.28 (0-70)
	18 < Model ≤ 24	0.04 (10)	0.10 (25)	0.16 (40)	0.22 (55)	0.28 (70)	0-0.40 (0-100)
	24 < Model ≤ 60	0.08 (20)	0.14 (35)	0.20 (50)	0.26 (65)	0.32 (80)	0-0.40 (0-100)
Factory Setting		√					

CTBU-09HWFN1-M(C),

Code 0

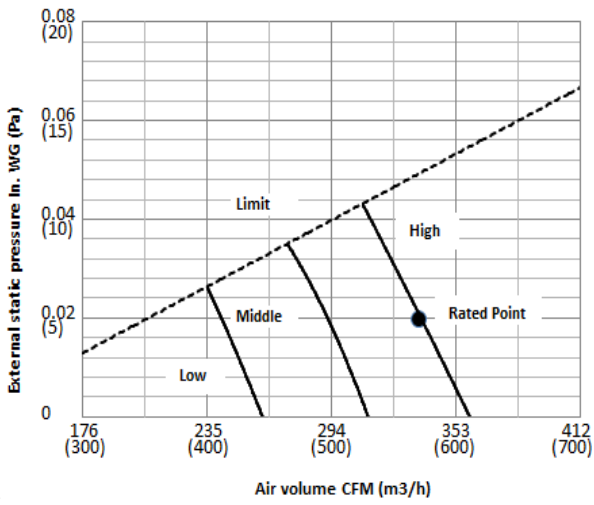

Code 1

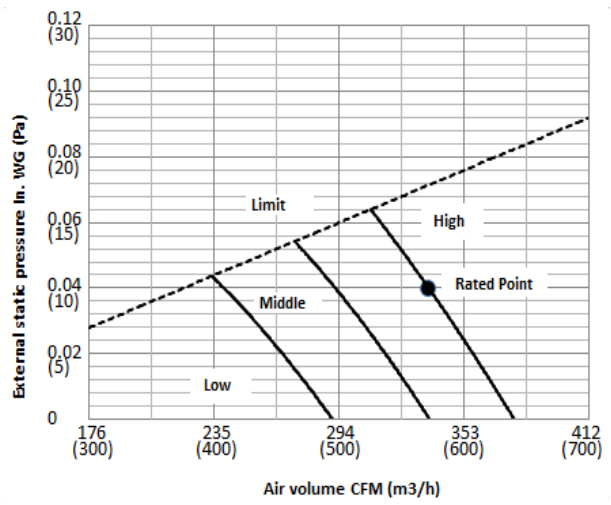

Code 2

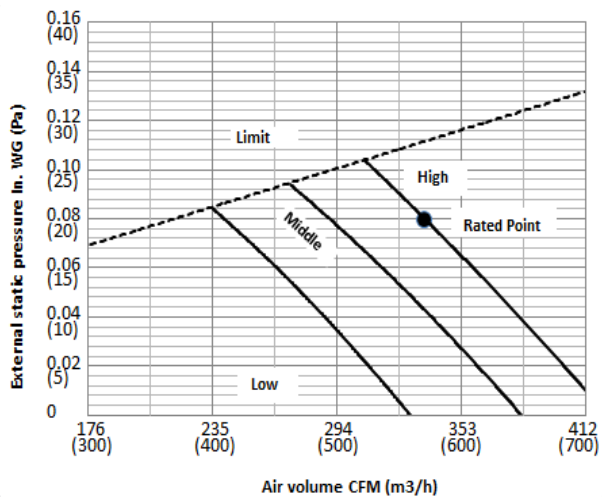

Code 3

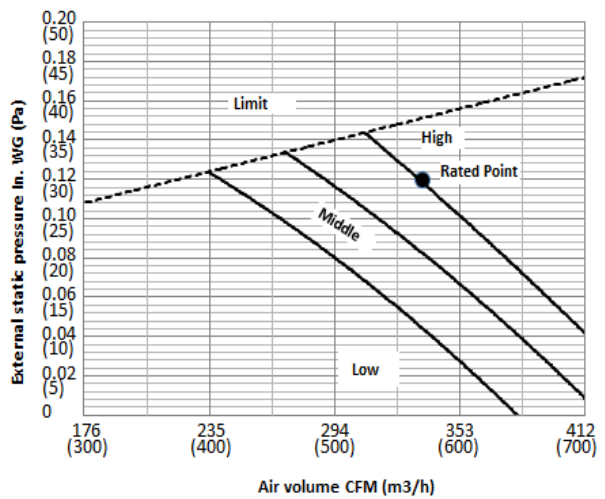

Code 4

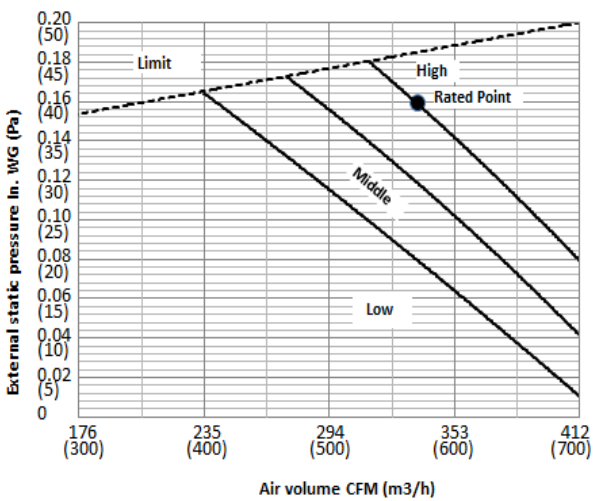

CTBU-12HWFN1-M(C)

Code 0

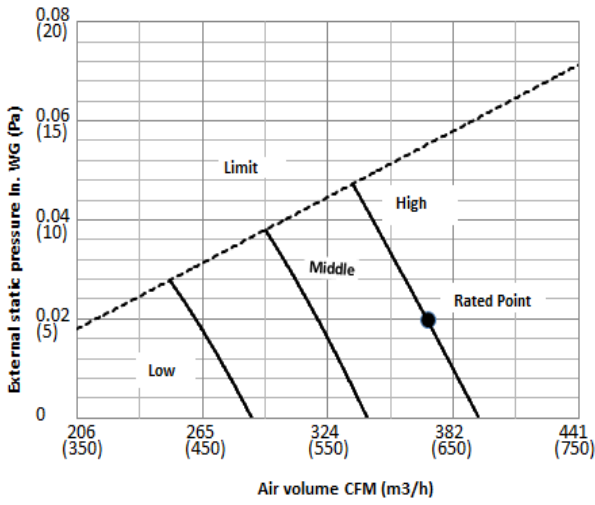

Code 1

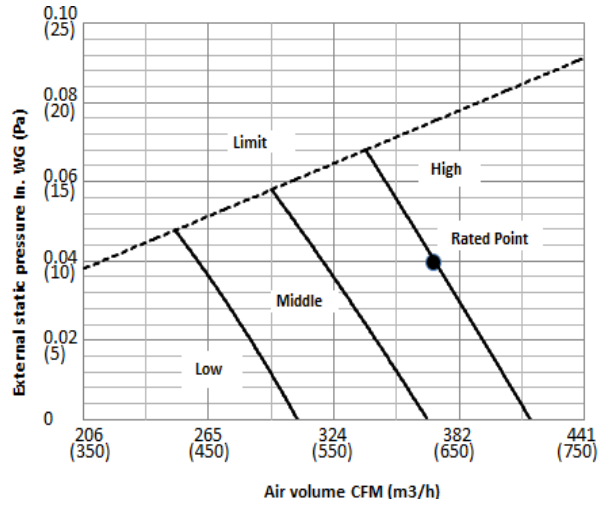

Code 2

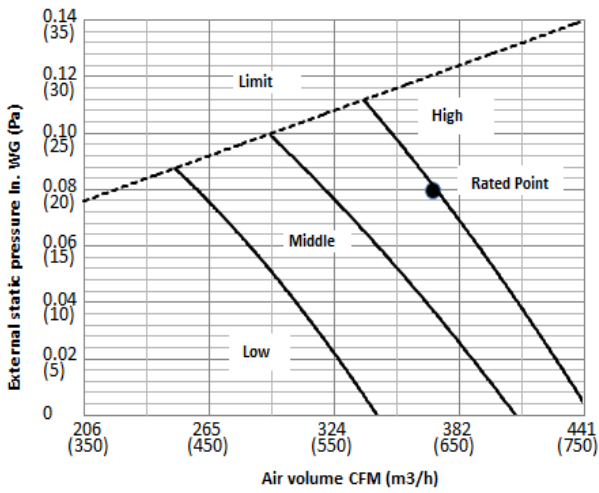

Code 3

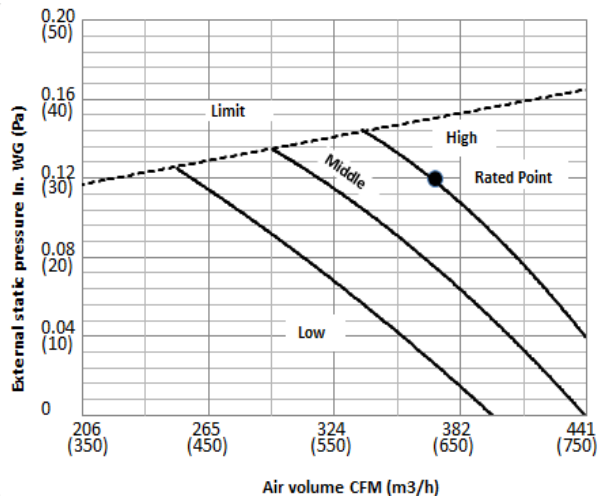

Code 4

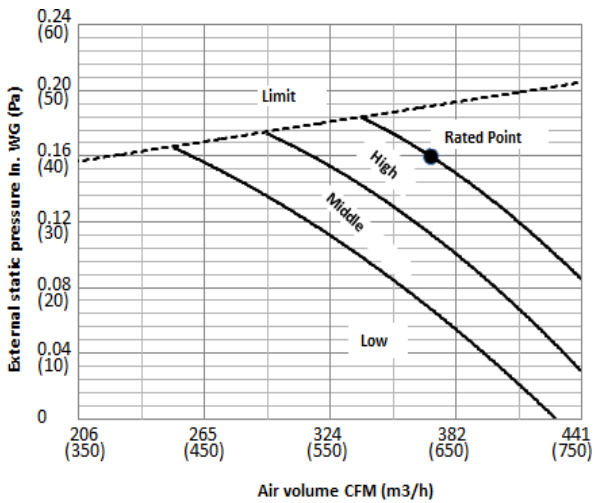

CTBU-18HWFN1-M(C)

Code 0

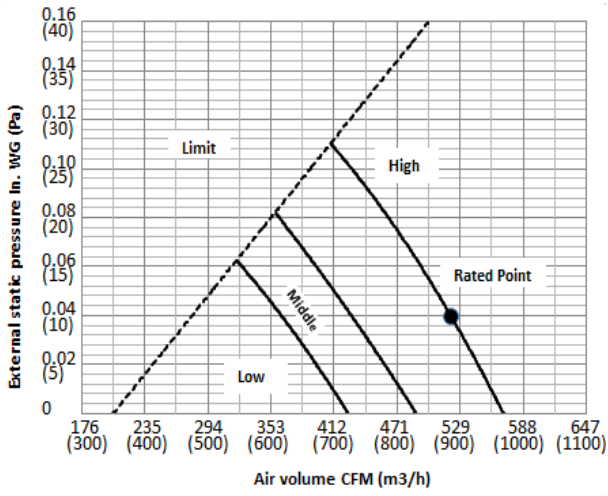

Code 1

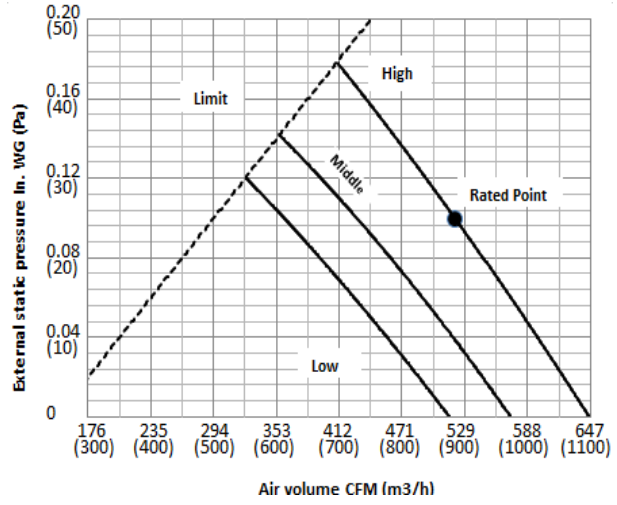

Code 2

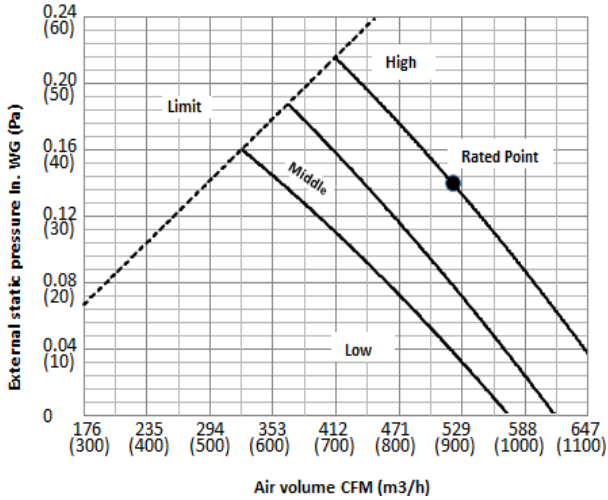

Code 3

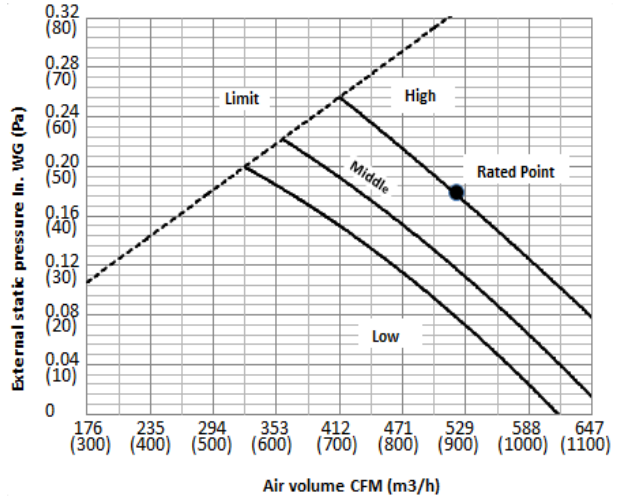

Code 4

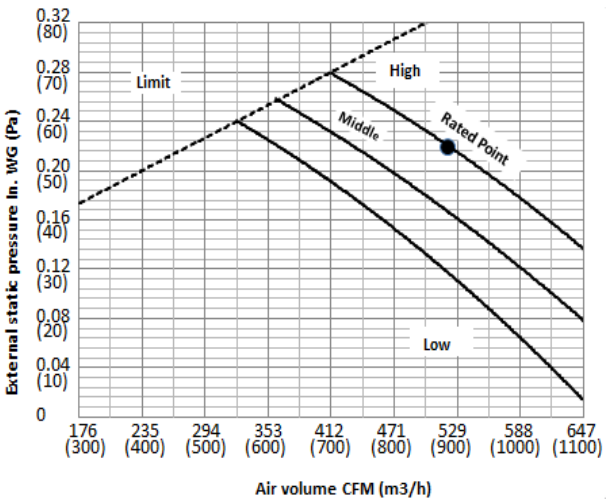

CTBU-24HWFN1-M(C)

Code 0

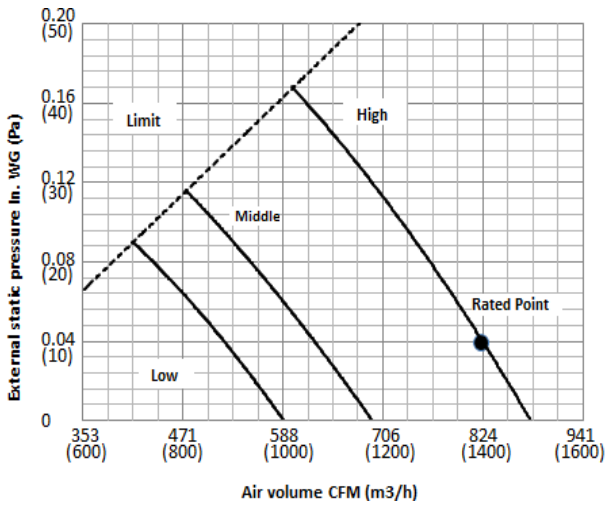

Code 1

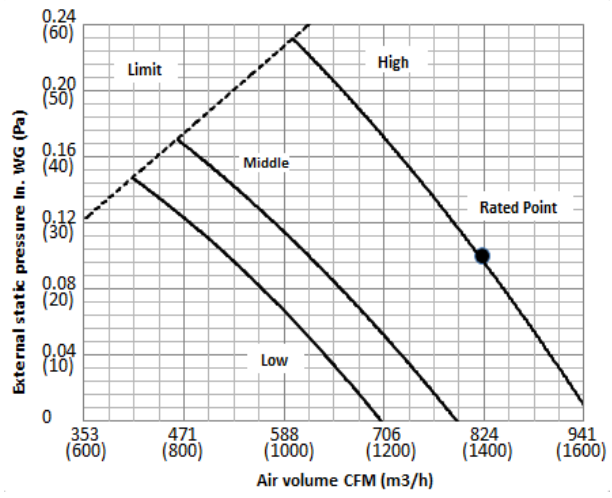

Code 2

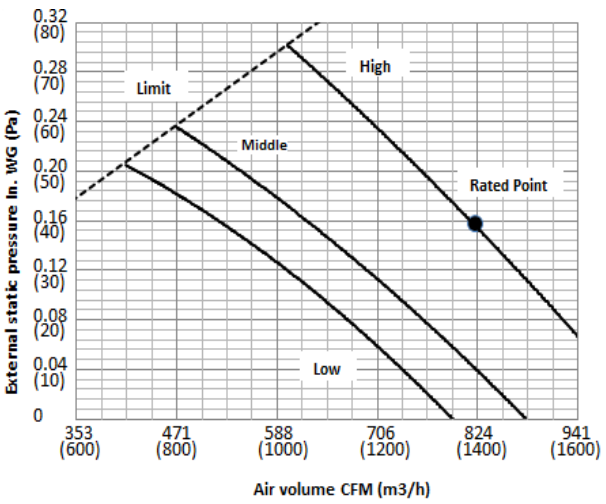

Code 3

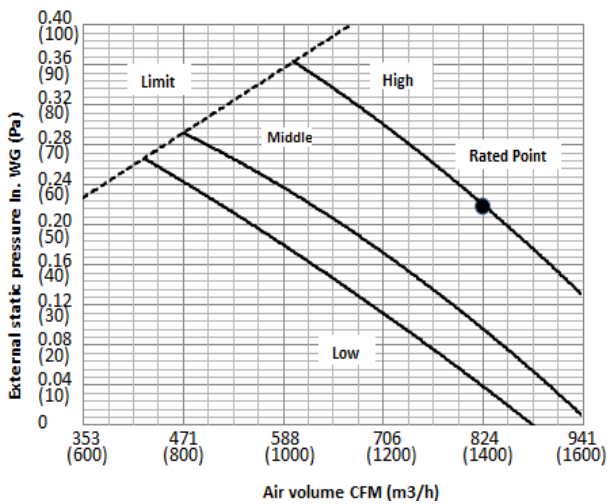

Code 4

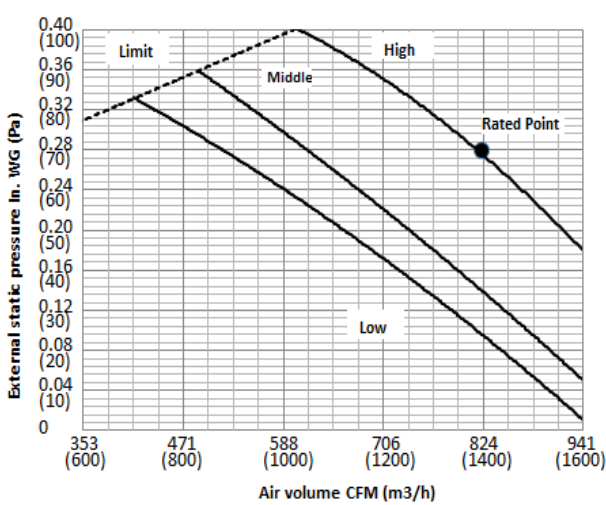

CTB-36HWFN1-M(C)

Code 0

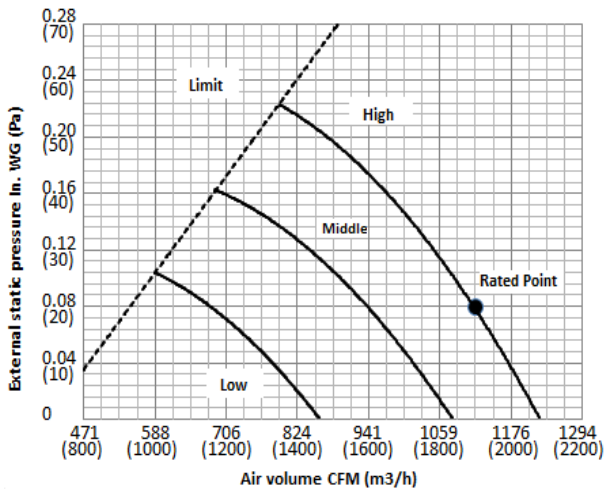

Code 1

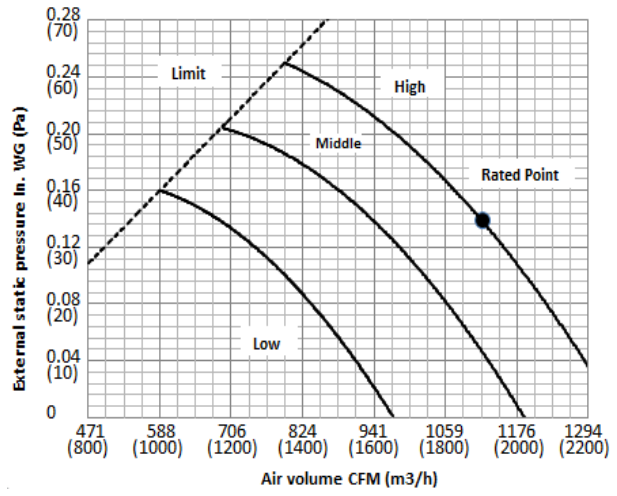

Code 2

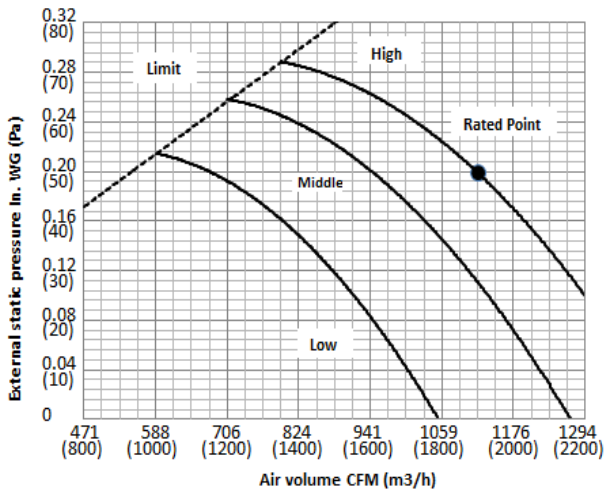

Code 3

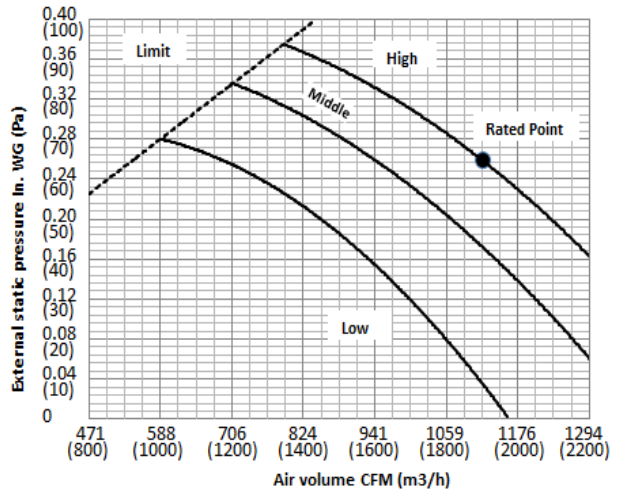

Code 4

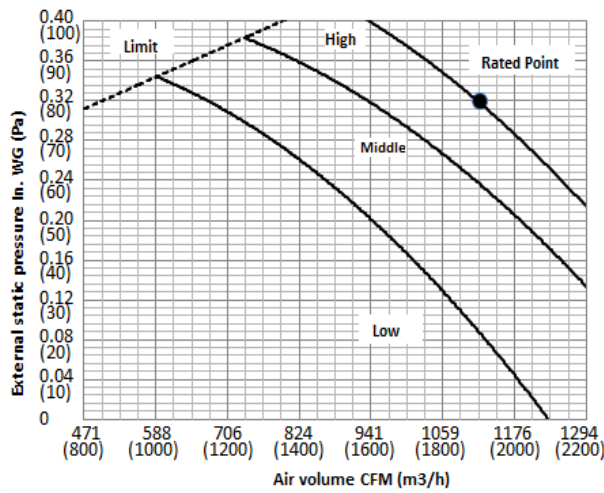

CTB-48HWFN1-M(C)

Code 0

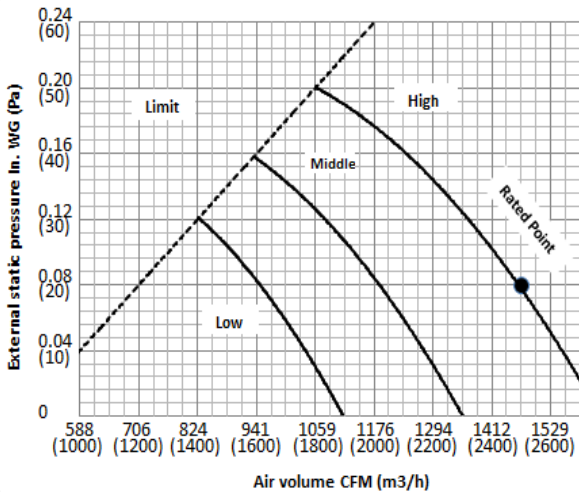

Code 1

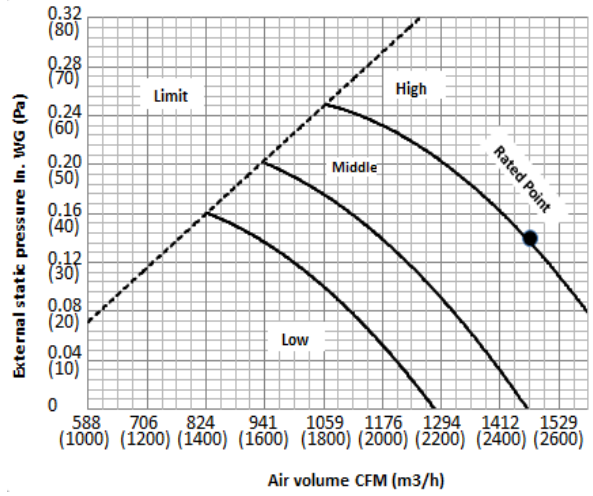

Code 2

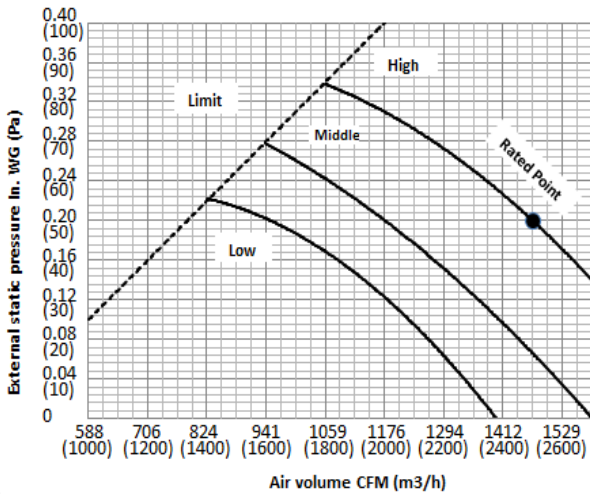

Code 3

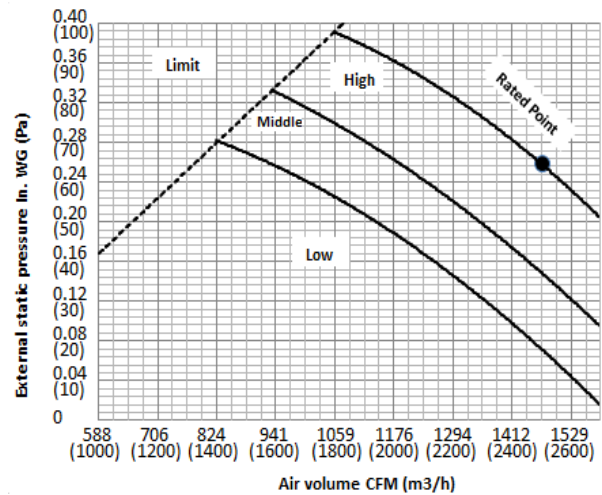

Code 4

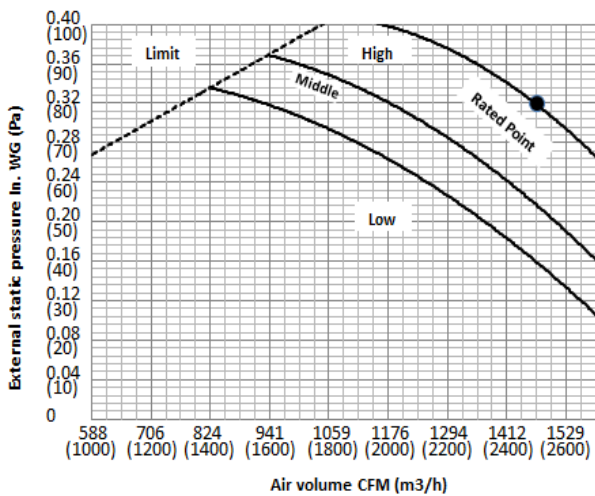

MTIU-09HWFN1-M,

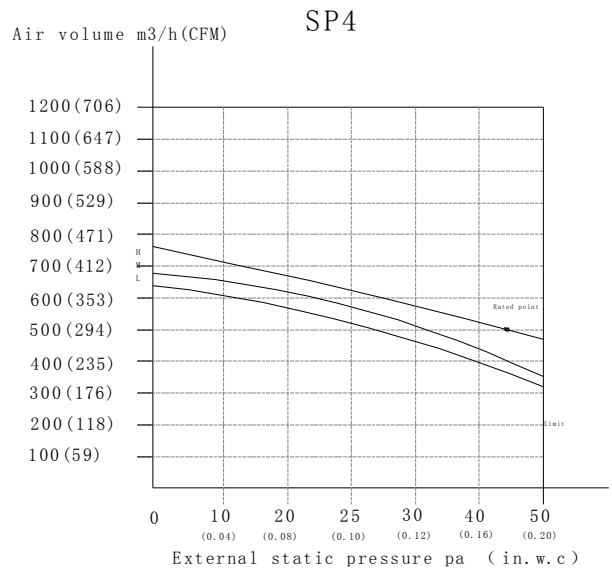
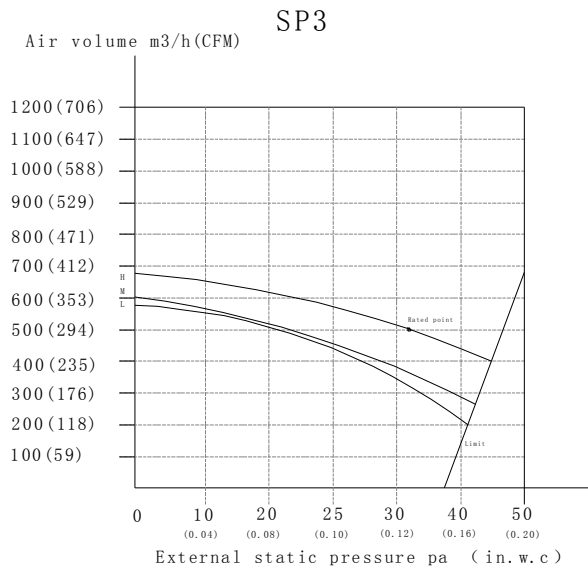
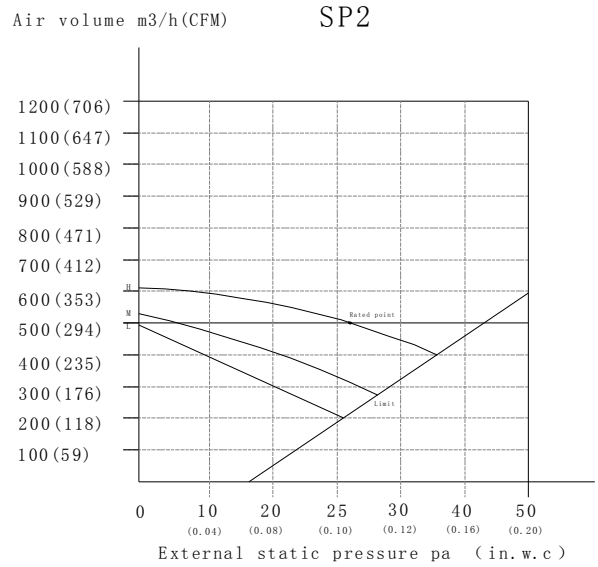
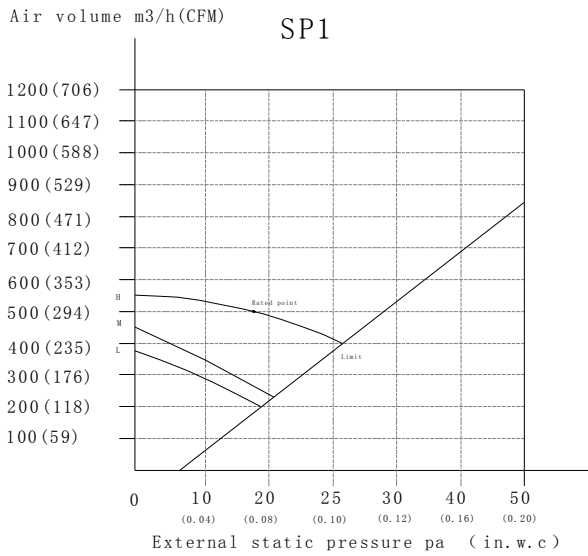

MTIU-12HWFN1-M

Air volume m³/h(CFM)

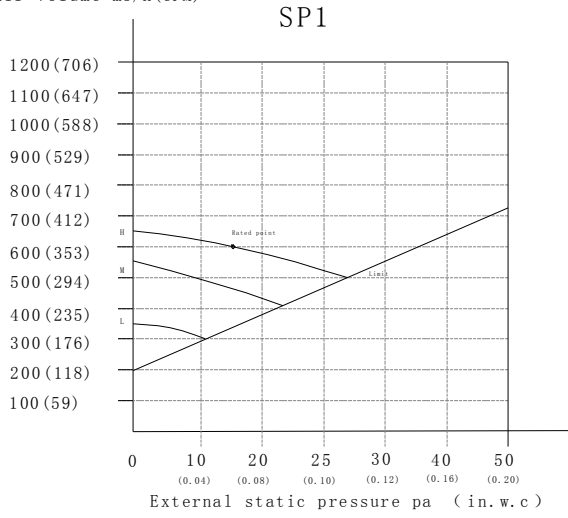

Air volume m³/h(CFM)

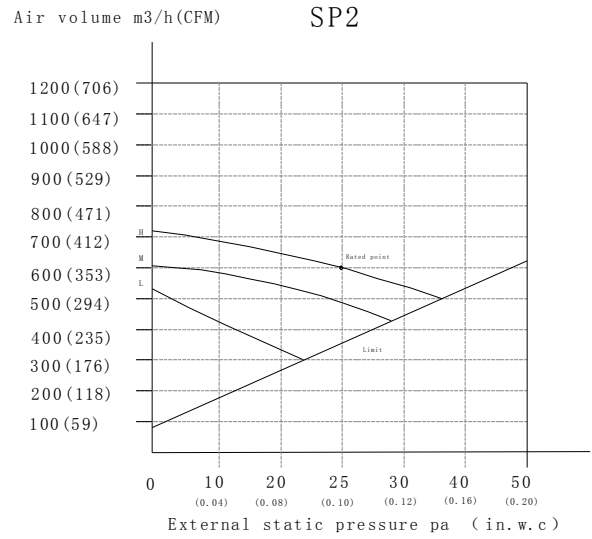

Air volume m³/h(CFM)

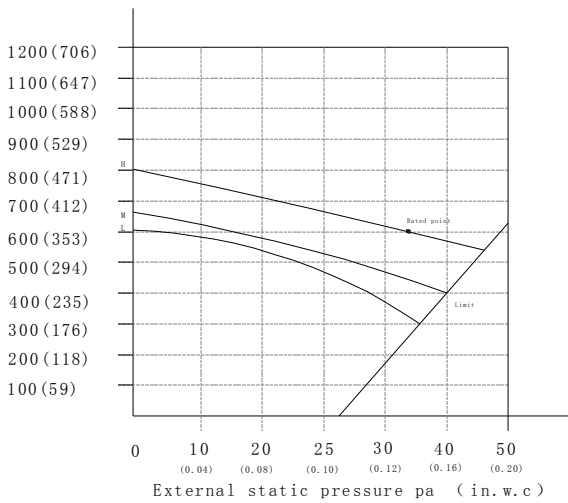

Air volume m³/h(CFM)

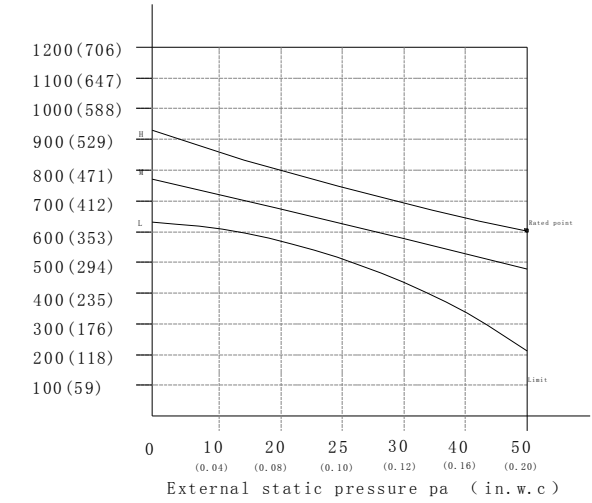

MTIU-18HWFN1-M

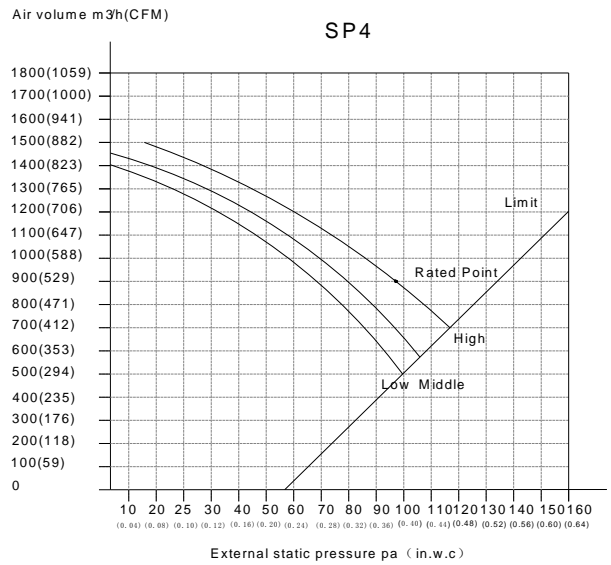
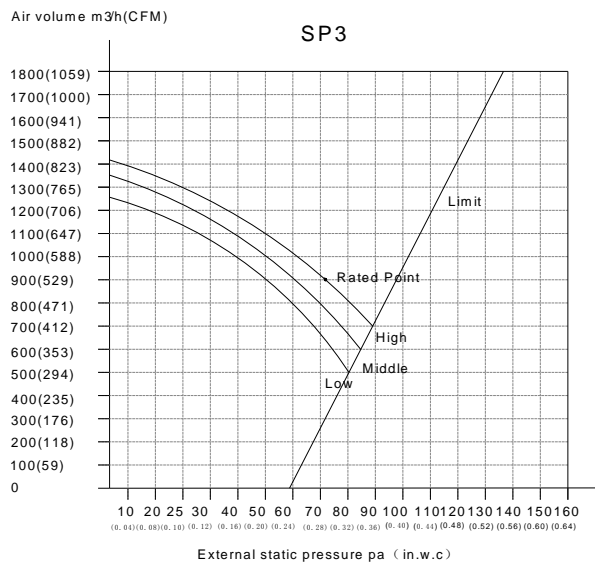
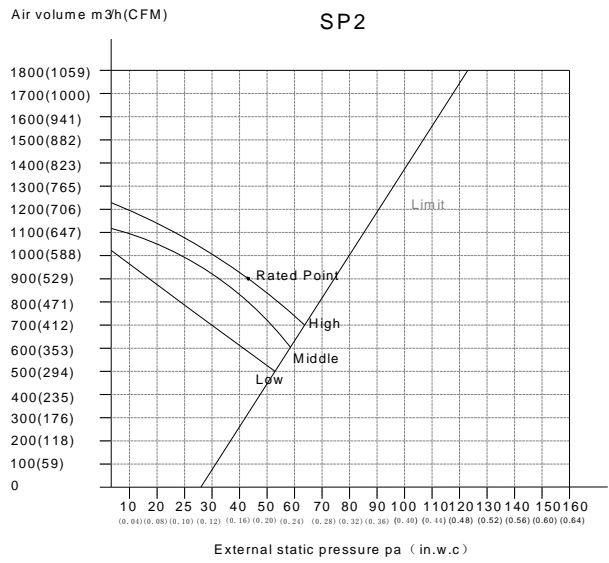
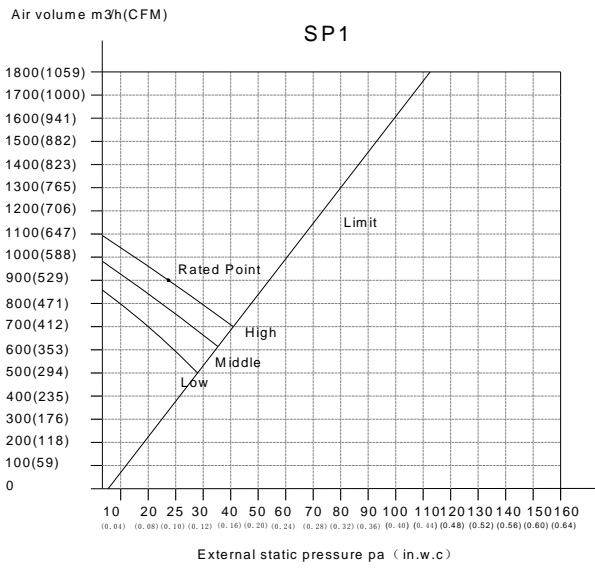

MTIU-24HWFN1-M

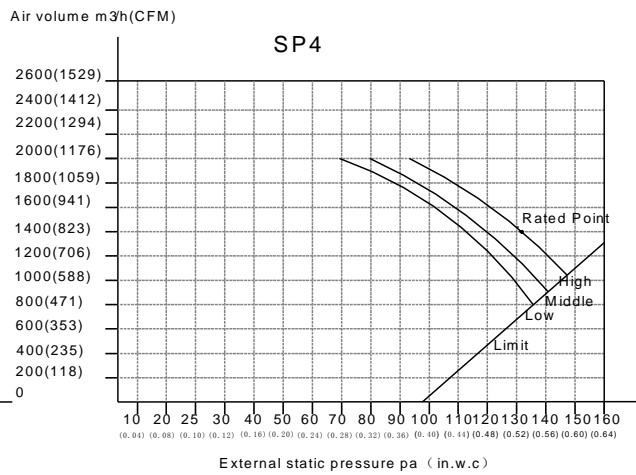
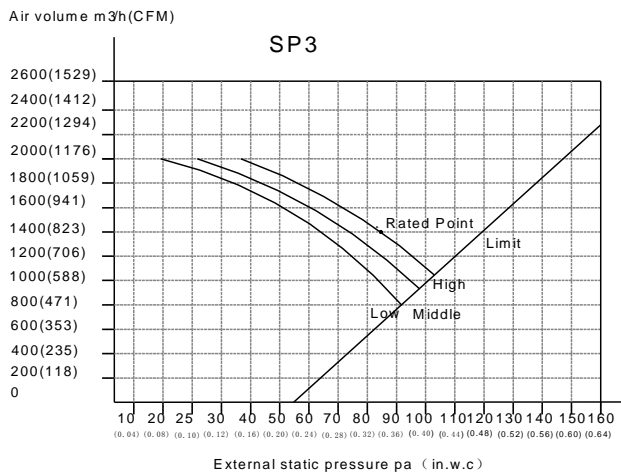
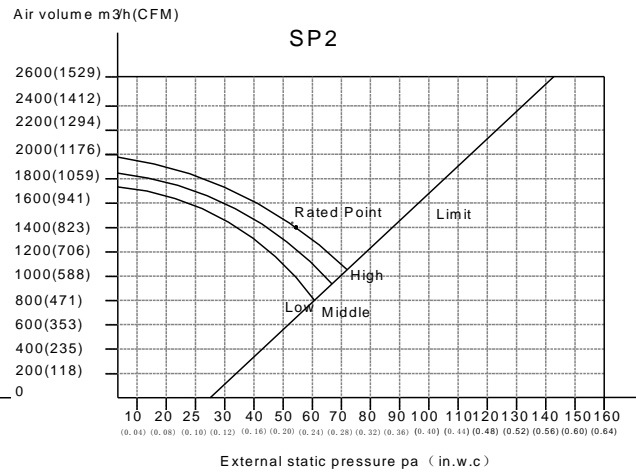
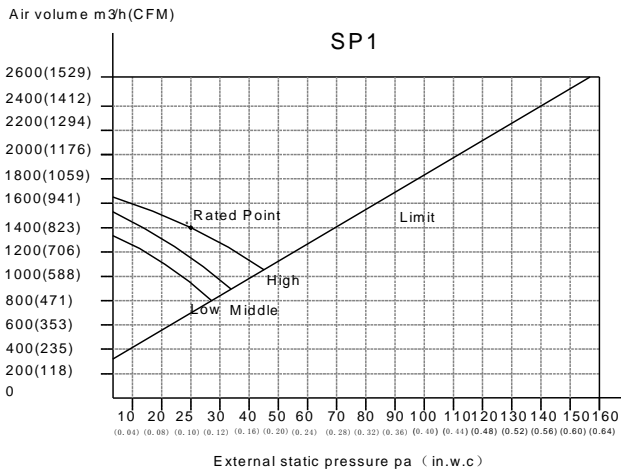

MTI-36HWFN1-M

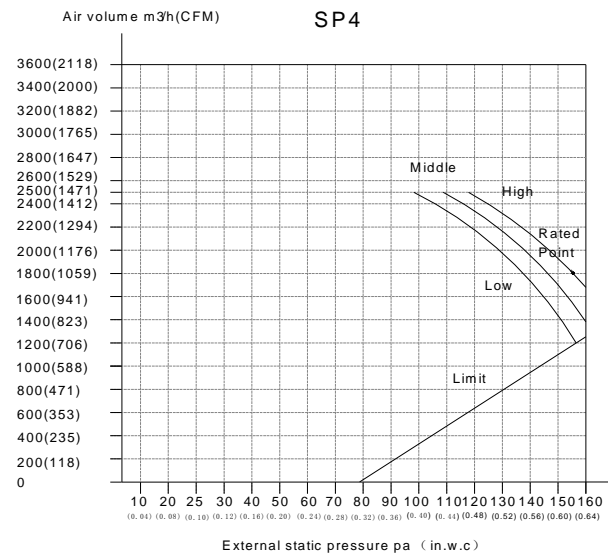
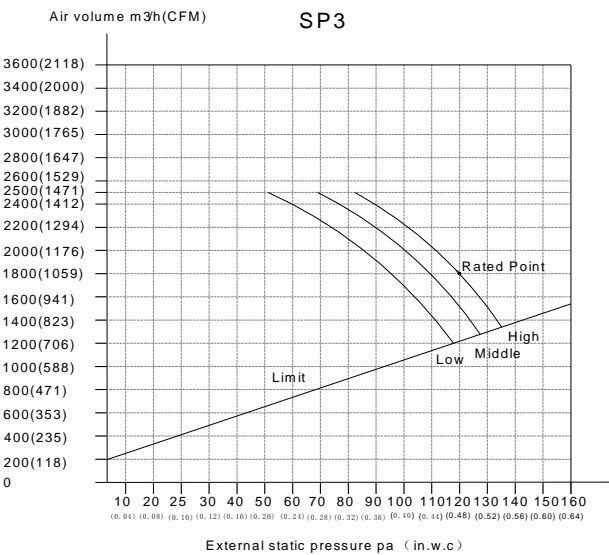
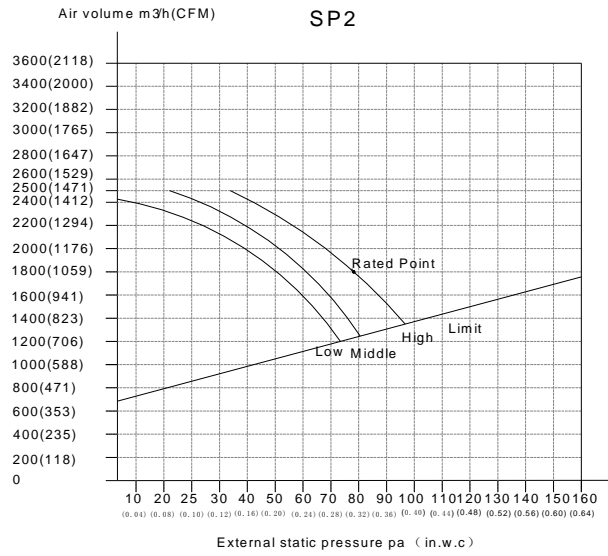
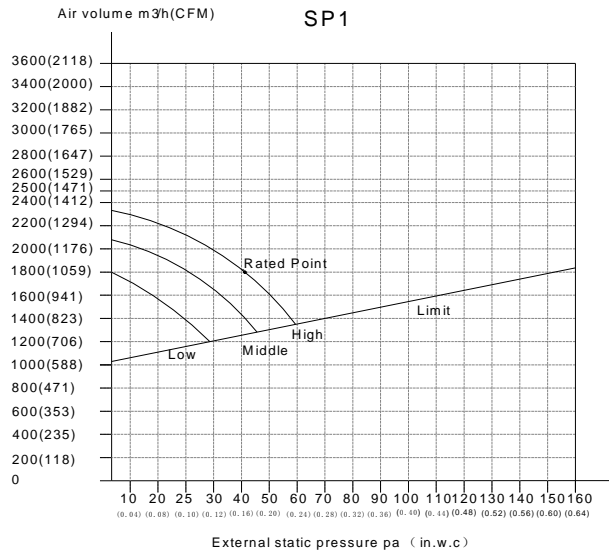

MHG-60HWFN1-MW

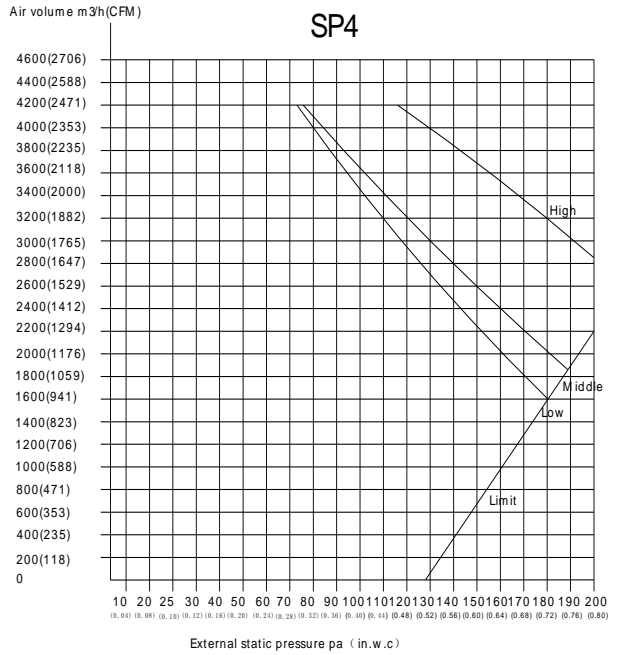
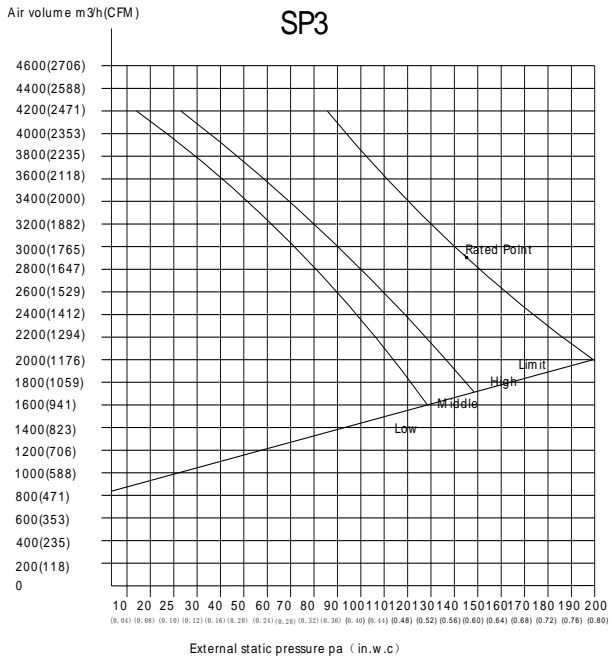
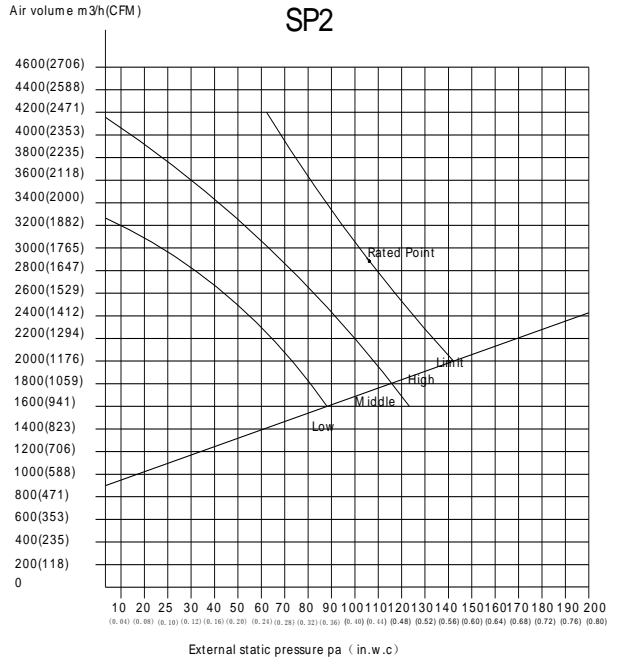
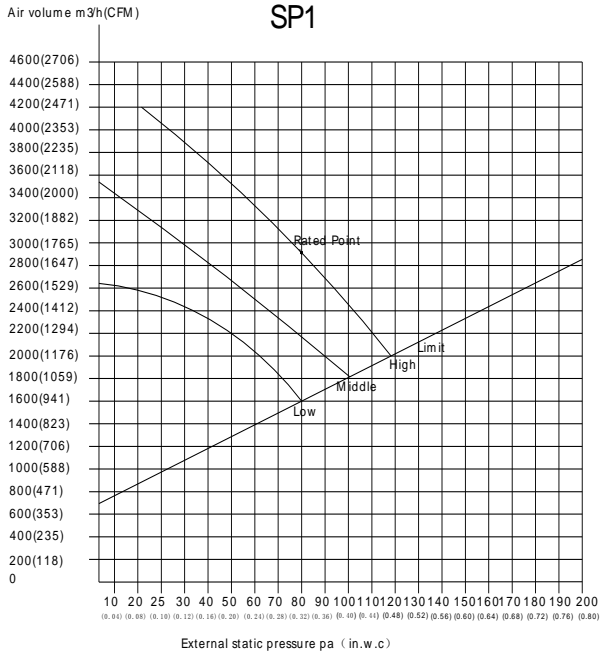

8 Electric Characteristics

Model	Indoor Unit			
	Hz	Voltage	Min.	Max.
CCA3U-09HRFN1-M(C)	60	208-230V	187V	253V
CTBU-09HWFN1-M(C)	60	208-230V	187V	253V
MTIU-09HWFN1-M	60	208-230V	187V	253V
CFAU-09HRFN1-M(C)	60	208-230V	187V	253V
CCA3U-12HRFN1-M(C)	60	208-230V	187V	253V
CTBU-12HWFN1-M(C)	60	208-230V	187V	253V
MTIU-12HWFN1-M	60	208-230V	187V	253V
CFAU-12HRFN1-M(C)	60	208-230V	187V	253V
CCA3U-18HRFN1-M(C)	60	208-230V	187V	253V
CTBU-18HWFN1-M(C)	60	208-230V	187V	253V
MUEU-18HRFN1-M(C)	60	208-230V	187V	253V
MTIU-18HWFN1-M	60	208-230V	187V	253V
MCD-24HRFN1-M(C)	60	208-230V	187V	253V
CTBU-24HWFN1-M(C)	60	208-230V	187V	253V
MUEU-24HRFN1-M(C)	60	208-230V	187V	253V
MTIU-24HWFN1-M	60	208-230V	187V	253V
MCD-36HRFN1-M(C)	60	208-230V	187V	253V
CTB-36HWFN1-M(C)	60	208-230V	187V	253V
MUE-36HRFN1-M(C)	60	208-230V	187V	253V
MTI-36HWFN1-M	60	208-230V	187V	253V
MCD-48HRFN1-M(D)	60	208-230V	187V	253V
CTB-48HWFN1-M(C)	60	208-230V	187V	253V
MUE-48HRFN1-M(C)	60	208-230V	187V	253V
MTI-48HWFN1-M	60	208-230V	187V	253V
MHG-60HWFN1-MW	60	208-230V	187V	253V
MUE-60HRFN1-MW	60	208-230V	187V	253V

9 Sound Level

9.1 Indoor unit

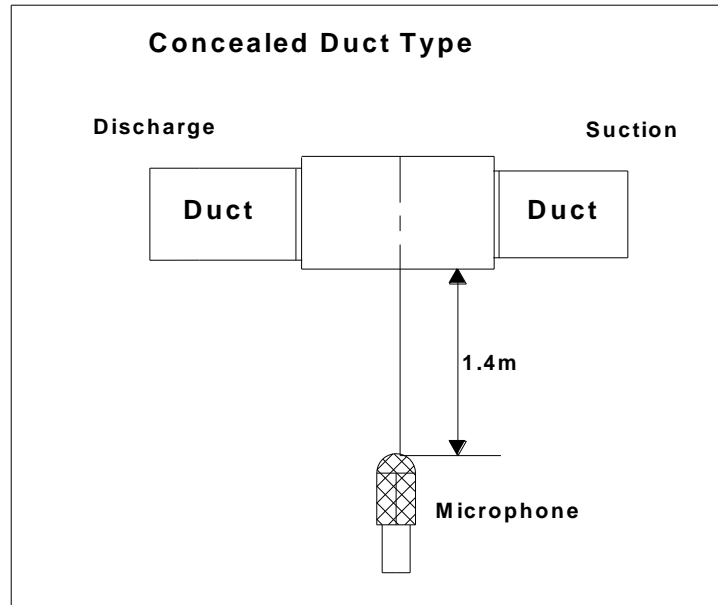

Model	Noise level dB(A)		
	H	M	L
CTBU-09HWFN1-M(C)	37	34	31
CTBU-12HWFN1-M(C)	39	36	32
CTBU-18HWFN1-M(C)	35	33	31
CTBU-24HWFN1-M(C)	50	47	45
CTBU-36HWFN1-M(C)	53	49	45
CTBU-48HWFN1-M(C)	44	47	41
MTIU-09HWFN1-M	37	32	30
MTIU-12HWFN1-M	38	33	30
MTIU-18HWFN1-M	39	37	35
MTIU-24HWFN1-M	44	40	35
MTI-36HWFN1-M	46	42	39
MTI-48HWFN1-M	52	49	46
MHG-60HWFN1-MW	57	54	51

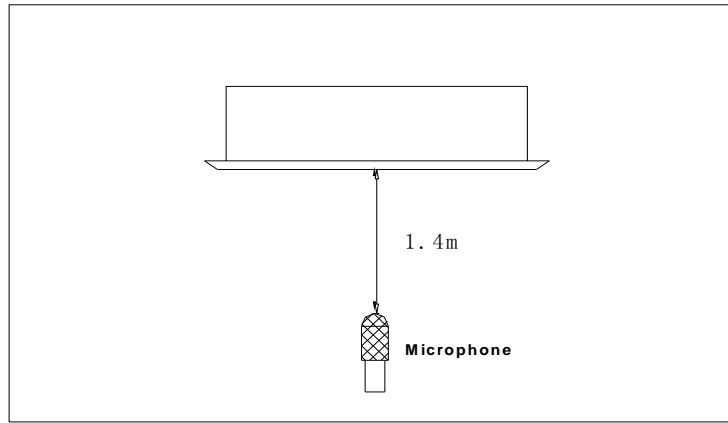

Model	Noise level dB(A)		
	H	M	L
CCA3U-09HRFN1-M(C)	41	39	37
CCA3U-12HRFN1-M(C)	41	38	35
CCA3U-18HRFN1-M(C)	46	43	41
MCD-24HRFN1-M(C)	51	47	43
MCD-36HRFN1-M(C)	52	47	44
MCD-48HRFN1-M(C)	53	49	45

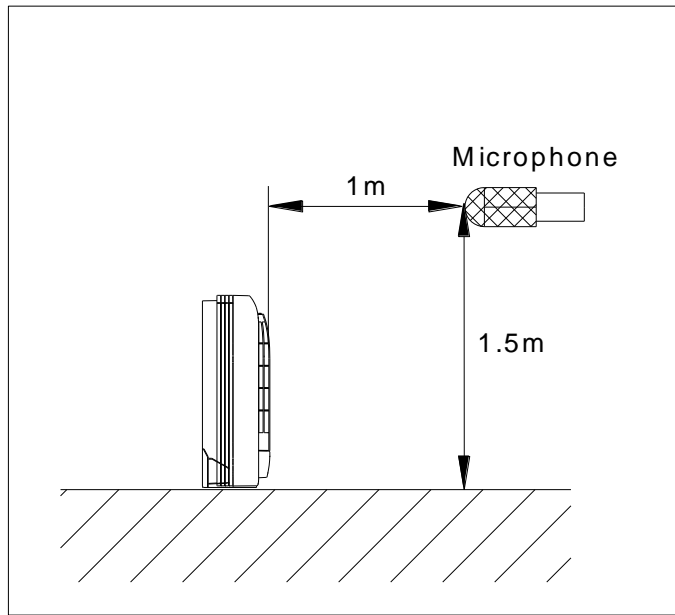

Model	Noise level dB(A)		
	H	M	L
CFAU-09HRFN1-M(C)	45	41	35
CFAU-12HRFN1-M(C)	44	42	38

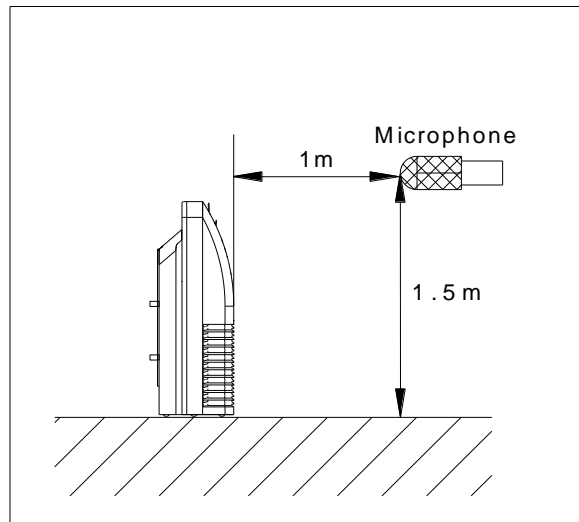
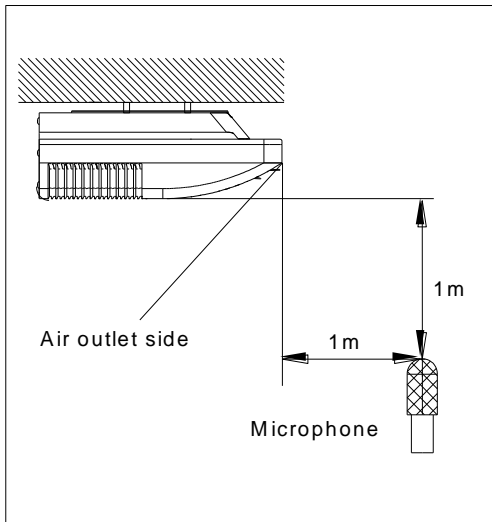

Model	Noise level dB(A)		
	H	M	L
MUBU-18HRFN1-M(C)	47	44	38
MUEU-24HRFN1-M(C)	53	49	45
MUE-36HRFN1-M(C)	55	48	41
MUE-48HRFN1-M(C)	57	54	52
MUE-60HRFN1-MW	55	49	46

9.2 Outdoor unit

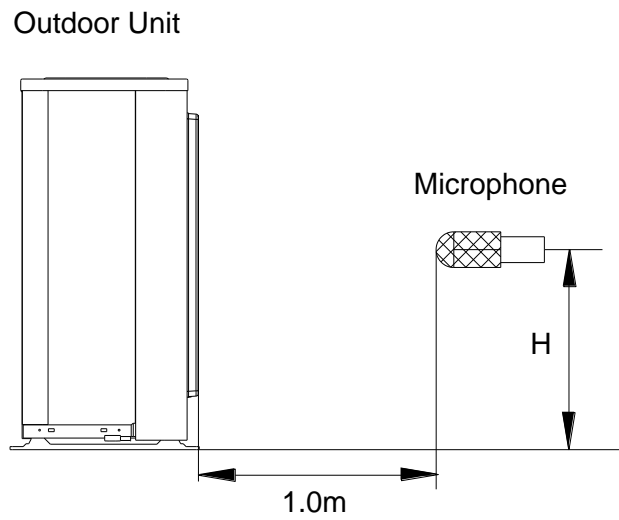









Note: $H = 0.5 \times \text{height of outdoor unit}$





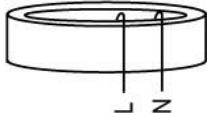

Model	Noise Level dB(A)
MOB30-09HFN1-MX0W MOB01-09HFN1-MW0W	59
MOBA30-09HFN1-MT0W	56
MOB30-12HFN1-MT0W	57
MOB30-12HFN1-MV0W MOB01-12HFN1-MV0W	56
MOCA30-18HFN1-MT0W MOCA01-18HFN1-MT0W	59
MOCA31-18HFN1-MT0W	59
MOD30-24HFN1-MT0W MOD01-23HFN1-MT0W	61
MOD31-24HFN1-MT0W	61
MOD30U-36HFN1-M	65
MOE30U-48HFN1-M	63
MOE30U-60HFN1-M	64



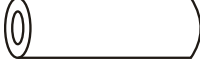
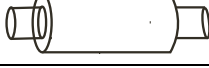

10 Accessories

Duct Units



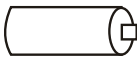

	Name	Shape	Quantity
Tubing & Fittings	Soundproof / insulation sheath		2
	Binding tape		1
	Seal sponge		1
Drainpipe Fittings (for cooling & heating)	Drain joint		1
	Seal ring		1
Wired controller & Its Frame	Wired controller		1
Others	Owner's manual		1
	Installation manual		1
EMS & It's fitting	Magnetic ring (twist the electric wires L and N around it to five circles)		1

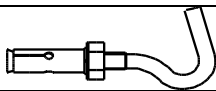
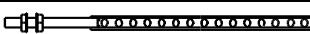
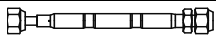
Cassette Units



	Name	Shape	Quantity
Installation Fittings	Installation paper board		1
Tubing & Fittings	Soundproof / insulation sheath		1
Drainpipe Fittings	Out-let pipe sheath		1
	Out-let pipe clasp		1
	Drain joint		1
	Seal ring		1
Remote controller & Its Frame (The product you have might not be provided the following accessories)	Remote controller & Its Frame		1
	Remote controller holder		1

	Mounting screw(ST2.9×10-C-H)		2
	Remote controller manual		1
	Alkaline dry batteries (AM4)		2
Others	Owner's manual		1
	Installation manual		1
Installation accessory (The product you have might not be provided the following accessories	Expansible hook		4
	Installation hook		4
	Orifice		1

Console Units

	Name	Shape	Quantity
Installation fittings	Hook		2
Remote controller & Its Frame	Remote controller		1
	Frame		1
	Mounting screw(ST2.9×10-C-H)		2
	Alkaline dry batteries (AM4)		2
Others	Installation manual	/	1
	Owner's manual	/	1

Ceiling-floor Units

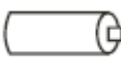
	Name	Shape	Quantity
Remote controller & Its holder	1. Remote controller		1
	2. Remote controller holder		1
	3. Mounting screw (ST2.9×10-C-H)		2
	4. Alkaline dry batteries (AM4)		2
Others	5. Owner's manual	—	1
	6. Installation manual	—	1
	7. Remote controller manual	—	1

11. The Specification of Power

Type		9K-18K	24K
Power	Phase	1-phase	1-phase
	Frequency and Voltage	208-230V, 60Hz	208-230V, 60Hz
Circuit Breaker/ Fuse (A)		25/20	25/20
Indoor Unit Power Wiring		—————	—————
Indoor/Outdoor Connecting Wiring	Outdoor Unit Power Wiring	3-core cable (14AWG)	3-core cable (14AWG)
	Strong Electric Signal	4-core cable (16AWG)	4-core cable (16AWG)
		4-core cable (14AWG)(with auxiliary electric heater)	4-core cable (14AWG)(with auxiliary electric heater)
	Weak Electric Signal	—————	—————

Model		36K	48K/60k
Power	Phase	1-phase	1-phase
	Frequency and Voltage	208-230V, 60Hz	208-230V, 60Hz
Circuit Breaker/ Fuse (A)		40/30	50/40
Indoor Unit Power Wiring		—————	—————
Indoor/Outdoor Connecting Wiring	Outdoor Unit Power Wiring	3-core cable 12AWG	3-core cable 10AWG
	Strong Electric Signal	3-core cable 16AWG	3-core cable 16AWG
		4-core cable (14AWG)(with auxiliary electric heater)	4-core cable (14AWG)(with auxiliary electric heater)
	Weak Electric Signal	2-core shielded cable 24AWG	2-core shielded cable 24AWG

12 Field Wiring

9K~24K

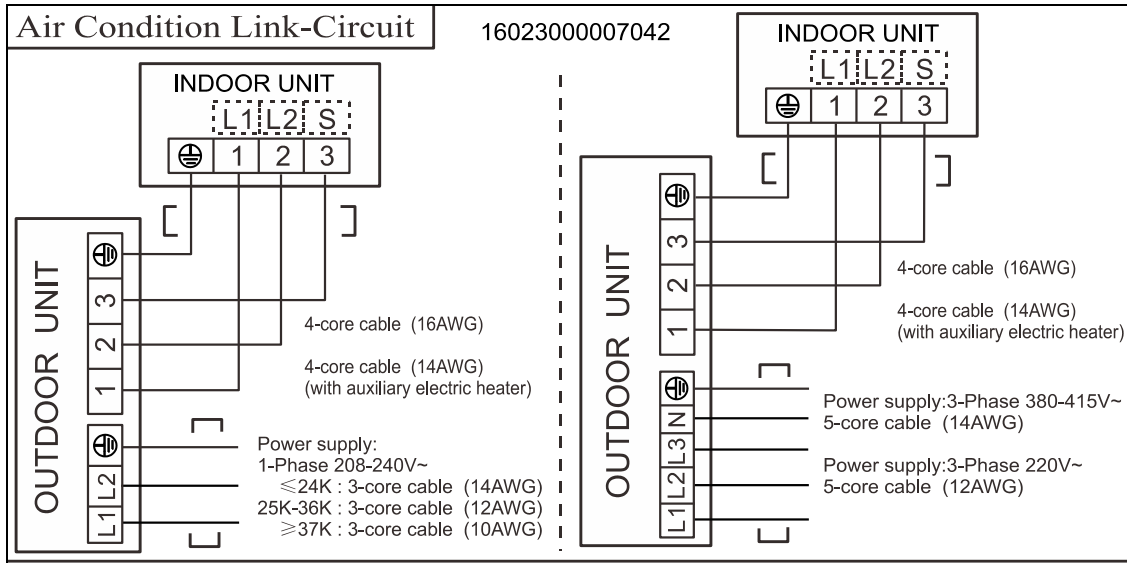

36K, 48K

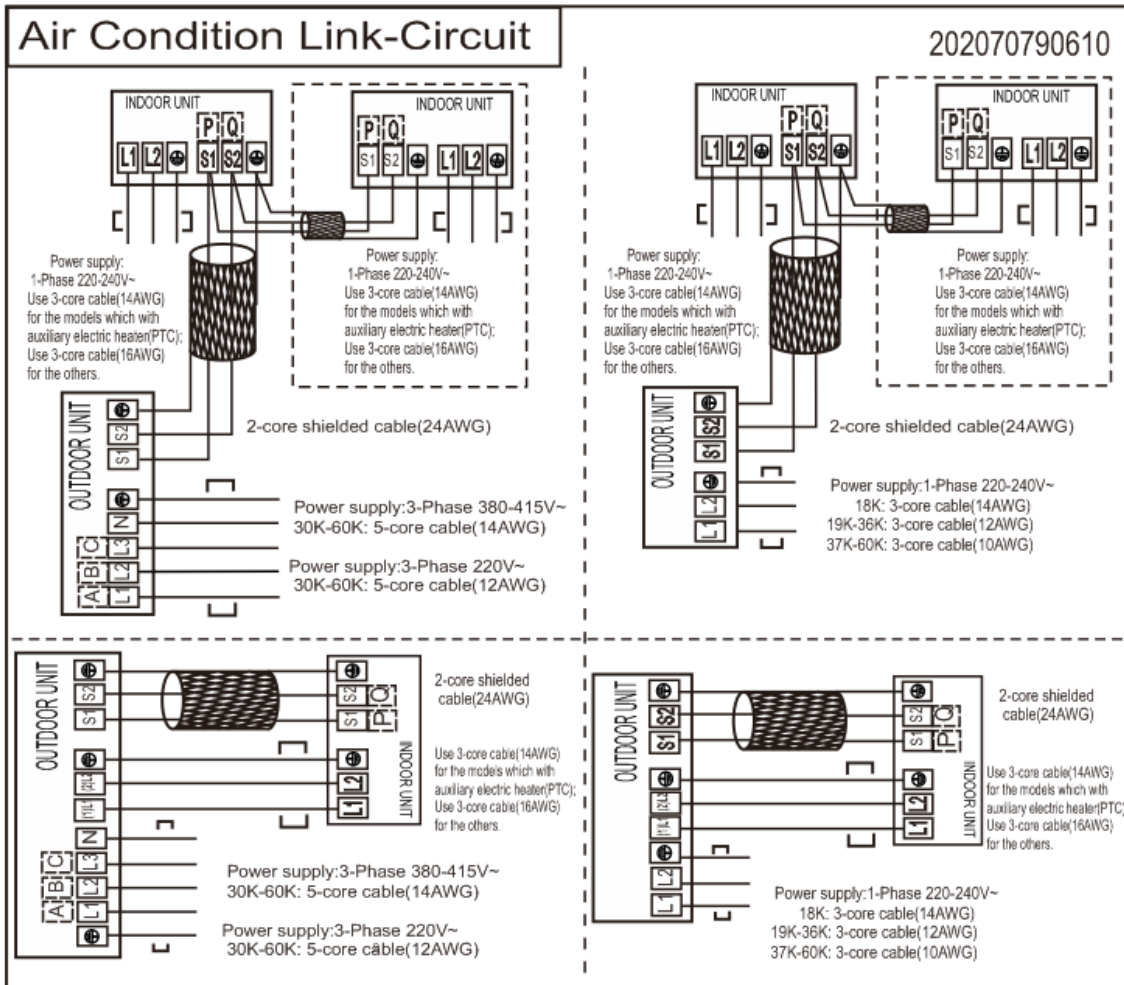

60K

Air Condition Link-Circuit

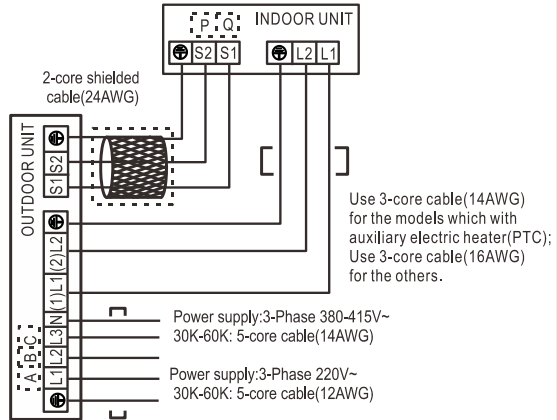
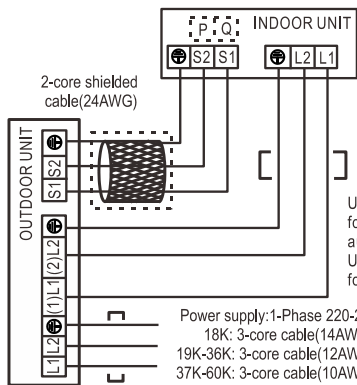

13 Installation Details

13.1 Location selection

13.1.1 Indoor unit location selection

- The place shall easily support the indoor unit's weight.
- The place can ensure the indoor unit installation and inspection.
- The place can ensure the indoor unit horizontally installed.
- The place shall allow easy water drainage.
- The place shall easily connect with the outdoor unit.
- The place where air circulation in the room should be good.
- There should not be any heat source or steam near the unit.
- There should not be any oil gas near the unit
- There should not be any corrosive gas near the unit
- There should not be any salty air neat the unit
- There should not be strong electromagnetic wave near the unit
- There should not be inflammable materials or gas near the unit
- There should not be strong voltage vibration.

13.1.2 Outdoor unit location selection

- The place shall easily support the outdoor unit's weight.
- Locate the outdoor unit as close to indoor unit as possible
- The piping length and height drop cannot exceed the allowable value.
- The place where the noise, vibration and outlet air do not disturb the neighbors.
- There is enough room for installation and maintenance.
- The air outlet and the air inlet are not impeded, and not face the strong wind.
- It is easy to install the connecting pipes and cables.
- There is no danger of fire due to leakage of inflammable gas.
- It should be a dry and well ventilation place
- The support should be flat and horizontal
- Do not install the outdoor unit in a dirty or severely polluted place, so as to avoid

blockage of the heat exchanger in the outdoor unit.

- If is built over the unit to prevent direct sunlight, rain exposure, direct strong wend, snow and other scraps accumulation, make sure that heat radiation from the condenser is not restricted.

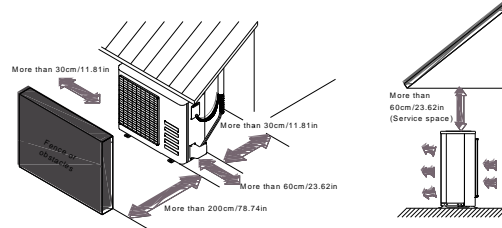

13.2 Indoor unit installation

13.2.1 A5&A6 Duct indoor unit installation

13.2.1.1 Service space for indoor unit

A5/A6 Duct

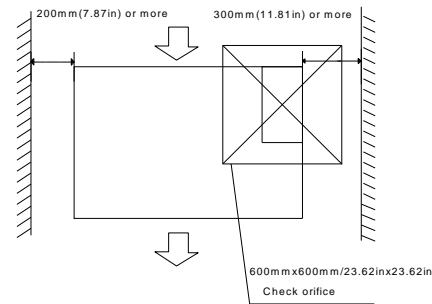

13.2.1.2 Bolt pitch

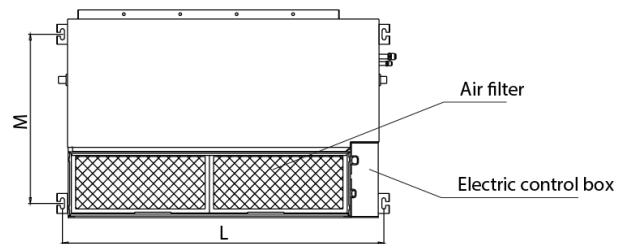

Model	Size of outline dimension mounted plug	
	L	M
CTBU-09HWFN1-M(C) CTBU-12HWFN1-M(C)	740 29.13	350 13.78
CTBU-18HWFN1-M(C)	960	350
	37.80	13.78
CTBU-24HWFN1-M(C)	960	350
	37.80	13.78
CTB-36HWFN1-M(C)	1180	490
	46.46	19.29
CTB-48HWFN1-M(C)	1240	500

	48.82	19.69
MTIU-09HWFN1-M/ MTIU-12HWFN1-M	741	360
	29.2	14.2
MTIU-18HWFN1-M	920	508
	36.22	20
MTIU-24HWFN1-M	1140	598
	44.88	23.54
MTI-36HWFN1-M	1400	598
	55.12	23.54
MTI-48HWFN1-M	1240	697
	48.82	27.44

13.2.1.3 Hang indoor unit

1. Please refer to the upper data to locate the four positioning screw bolt hole on the ceiling. Be sure to mark the areas where ceiling hook holes will be drilled.
2. Install and fit pipes and wires after you have finished installing the main body. When choosing where to start, determine the direction of the pipes to be drawn out. Especially in cases where there is a ceiling involved, align the refrigerant pipes, drain pipes, and indoor and outdoor lines with their connection points before mounting the unit.
3. Install hanging screw bolts.
 - Cut off the roof beam.
 - Strengthen the place that has been cut off, and consolidate the roof beam.
4. After you select an installation location, align the refrigerant pipes, drain pipes, as well as indoor and outdoor wires with their connection points before mounting the unit.
5. Drill 4 holes 10cm (4") deep at the ceiling hook positions in the internal ceiling. Be sure to hold the drill at a 90° angle to the ceiling.
6. Secure the bolt using the washers and nuts provided.
7. Install the four suspension bolts.
8. Mount the indoor unit with at least two people to lift and secure it. Insert suspension bolts into the unit's hanging holes. Fasten

them using the washers and nuts provided.

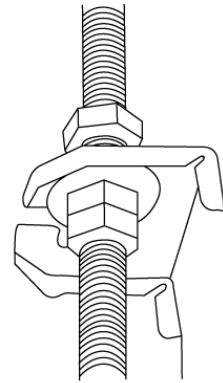

9. Mount the indoor unit onto the hanging screw bolts with a block. Position the indoor unit flat using a level indicator to prevent leaks.

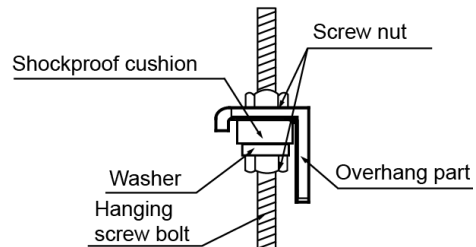

Note: Confirm the minimum drain tilt is 1/100 or more.

13.2.1.4 Duct and accessories installation

1. Install the filter (optional) according to the size of the air inlet.
2. Install the canvas tie-in between the body and the duct.
3. Air inlet and air outlet duct should be apart far enough to avoid air passage short-circuit.
4. Connect the duct according to the following diagram.

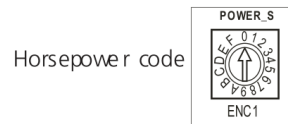
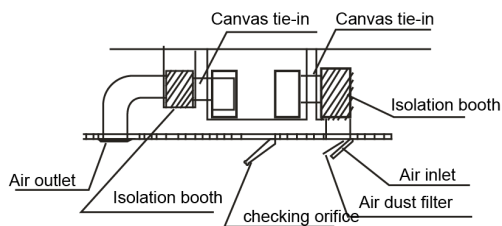

5. Please refer to the following static pressure to install.

Model	Static Pressure(Pa)
CTBU-09HWFN1-M(C)	0-45
CTBU-12HWFN1-M(C)	
CTBU-18HWFN1-M(C)	0-70
CTBU-24HWFN1-M(C)	0-100
CTB-36HWFN1-M(C)	0-100
CTB-48HWFN1-M(C)	0-100
MTIU-18HWFN1-M	0-100
MTIU-24HWFN1-M	0-160
MTI-36HWFN1-M	0-160
MTI-48HWFN1-M	0-160

Change the fan motor static pressure corresponding to external duct static pressure.
NOTE: 1. Do not put the connecting duct weight on the indoor unit.

2. When connecting duct, use inflammable canvas tie-in to prevent vibrating.
3. Insulation foam must be wrapped outside the duct to avoid condensate. An internal duct underlayer can be added to reduce noise, if the end-user requires.

13.2.1.5 Control (only for inverter A5 Duct units)

- The capacity of the system and the network address of the air-conditioner can be set by the switches on the indoor Main Control Board.
- Before setting, turn off the power. After setting, restart the unit.
- Setting is not allowed when the unit is power on.

1. Horsepower code setting

The capacity of the indoor unit has been set in the factory according to the below table.

ENC1	Toggle switch Code	Capacity(kw)
Note: The capacity has been set in the factory, anyone can't adjust it except the qualified person	4	5.3
	5	5.6
	7	7.1
	8	9.0
	9	10.5
		14
		16

2. Network address set

Every air-conditioner in network has only one network address to distinguish each other. Address code of air-conditioner in LAN is set by code switches S1 & S2 on the Main Control Board of the indoor unit, and the set range is 0-63.

Toggle switch set		Network address code
S1	S2	
		00~15
		16~31
		32~47
		48~63

13.2.1.6 Adjust the air inlet direction (From rear side to under-side)

For A5 Duct units

- ① Take off ventilation panel and flange, cut off the staples at side rail

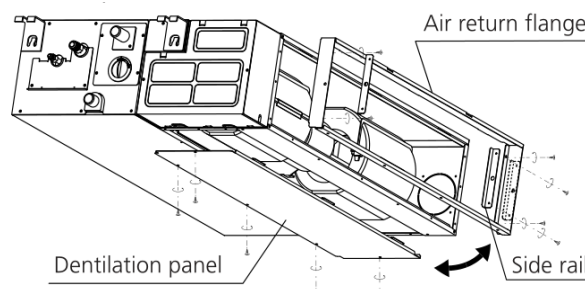

2. Stick the attached seal sponge as per the indicating place in the following fig, and then change the mounting positions of air return panel and air return flange.

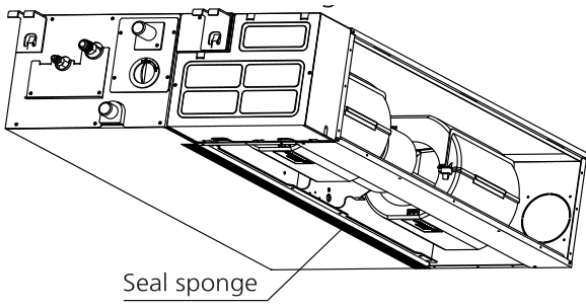

3. When installing the filter mesh, fit it into the flange inclined from air return opening, and then push up.

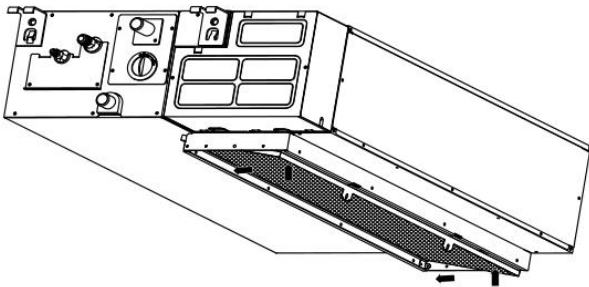

4. The installation has finish, upon filter mesh which fixing blocks have been insert to the flange positional holes.

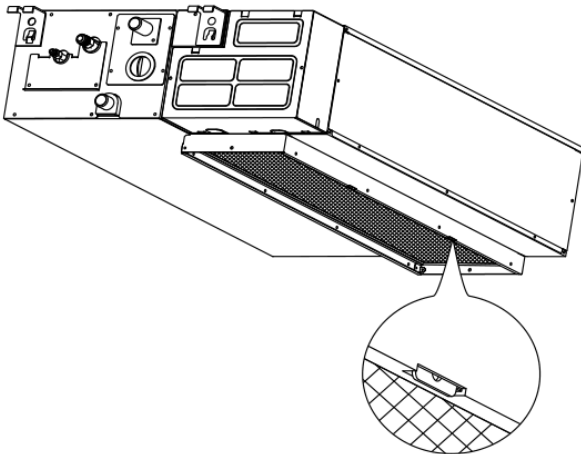

For A6 Duct units

1. Take off ventilation panel and flange, cut off the staples at side rail

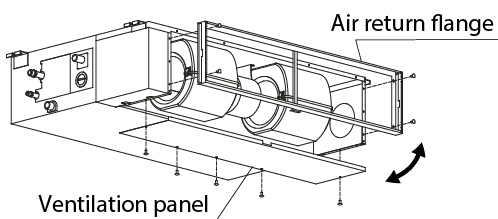

2. Change the mounting positions of ventilation panel and air return flange .

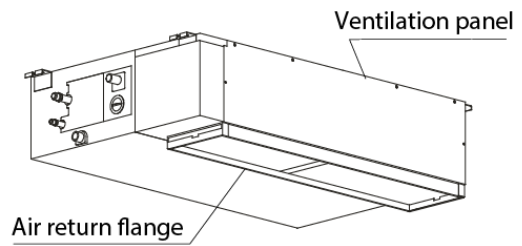

3. When installing the filter mesh, fit it into the flange as illustrated in the following figure.

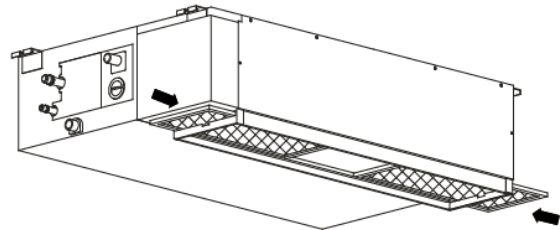

NOTE: All the figures in this manual are for demonstration purposes only. The air conditioner you have purchased may be slightly different in design, though similar in shape.

13.2.1.7 Fresh air duct installation

Dimension :

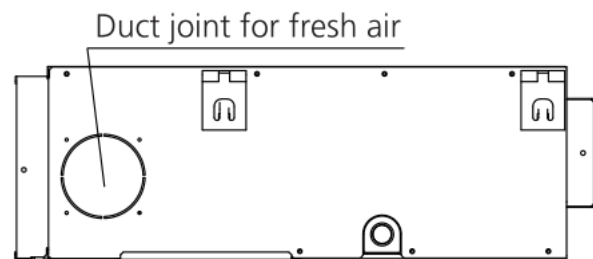

MODLE	
12-24	30-60

13.2.2 Compact cassette indoor unit installation

13.2.2.1 Service space for indoor unit

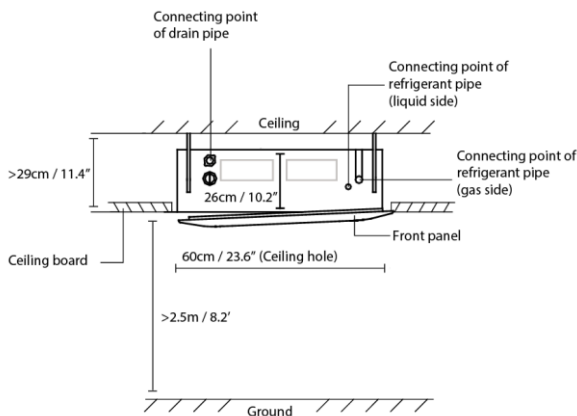
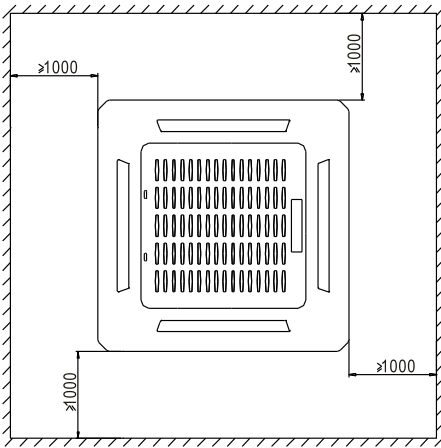

13.2.2.2 Bolt pitch

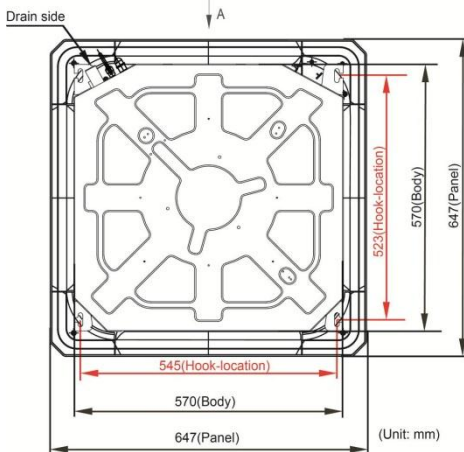

13.2.2.3 Install the pendant bolt

Select the position of installation hooks according to the hook holes positions showed in upper picture.

Drill four holes of $\varnothing 12\text{mm}$, 45~50mm deep at the selected positions on the ceiling. Then embed the expansible hooks (fittings).



Face the concave side of the installation hooks toward the expansible hooks. Determine the length of the installation hooks from the height of ceiling, then cut off the unnecessary part. If the ceiling is extremely high, please determine the length of the installation hook depending on the real situation.

13.2.2.4 Install the main body

Make the 4 suspender through the 4 hanger of the main body to suspend it. Adjust the hexangular nuts on the four installation hooks evenly, to ensure the balance of the body. Use a leveling instrument to make sure the levelness of the main body is within $\pm 1^\circ$.

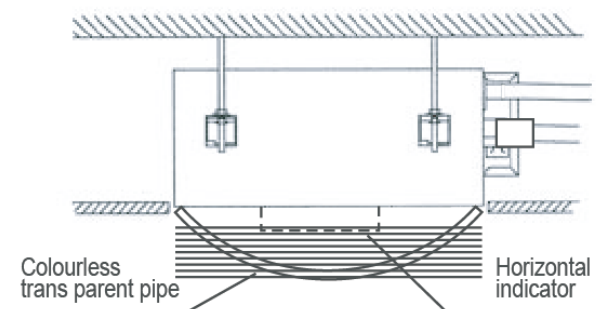

Adjust the position to ensure the gaps between the body and the four sides of ceiling are even. The body's lower part should sink into the ceiling for 10~12 mm. In general, L is half of the screw length of the installation hook.

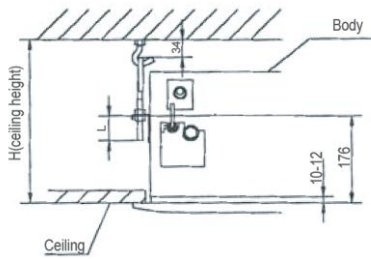

Locate the air conditioner firmly by wrenching the nuts after having adjusted the body's position well.



13.2.2.5 Install the panel

Remove the grille

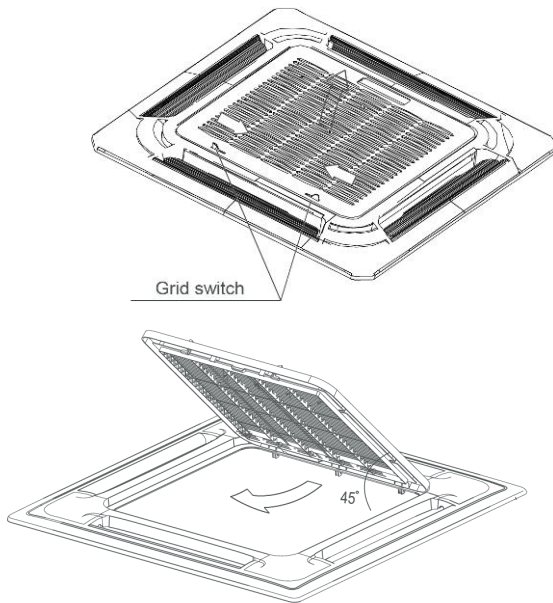

Hang the panel to the hooks on the mainbody.

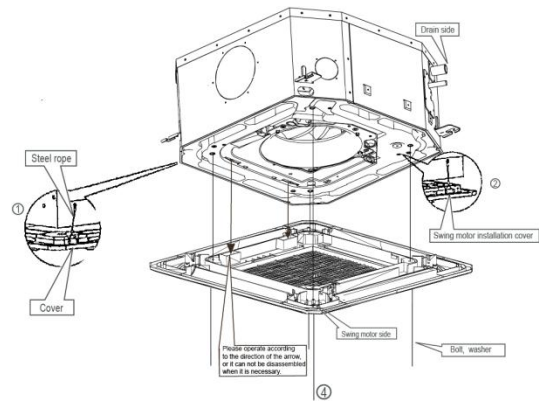

Tighten the screws under the panel hooks till the panel closely stick on the ceiling to avoid condensate water.

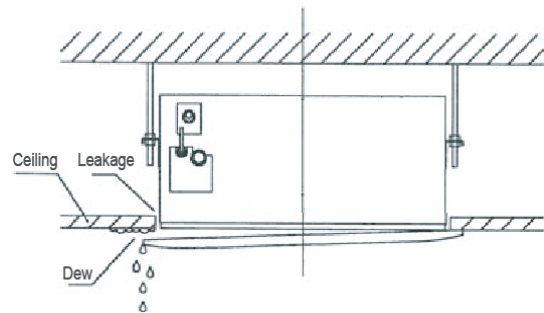
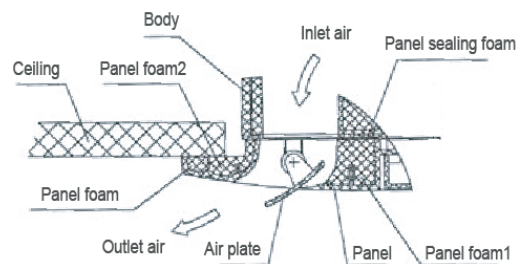

Hang the air-in grill to the panel, then connect the lead terminator of the swing motor and that of the control box with corresponding terminators on the body respectively.

Note: The panel shall be installed after the wiring connected.

13.2.3 Console indoor unit installation

13.2.3.1 Service space for indoor unit

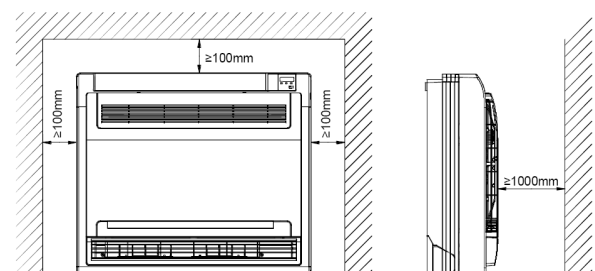

13.2.3.2 Install the main body

- Fix the hook with tapping screw onto the wall

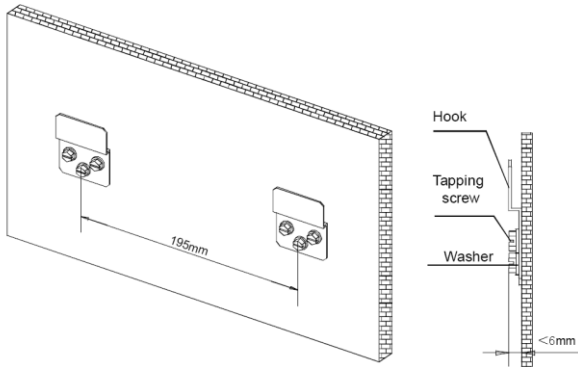

- Hang the indoor unit on the hook.
(The bottom of body can touch with floor or suspended, but the body must install vertically.)

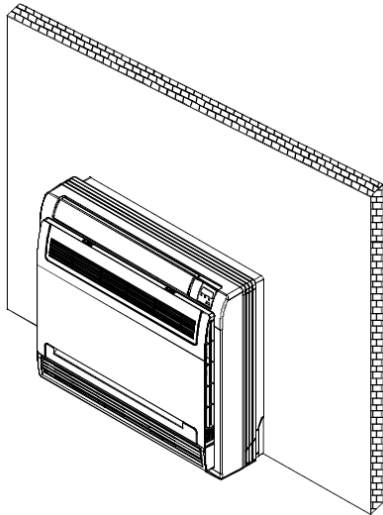

13.2.4 Ceiling-floor unit installation

13.2.4.1 Service space for indoor unit

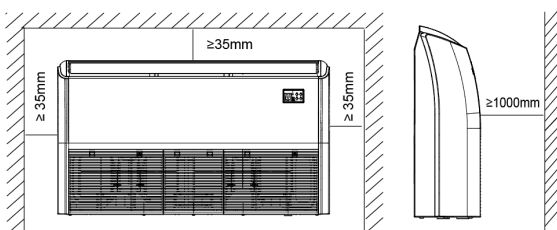

13.2.4.2 Bolt pitch

- ① Ceiling installation

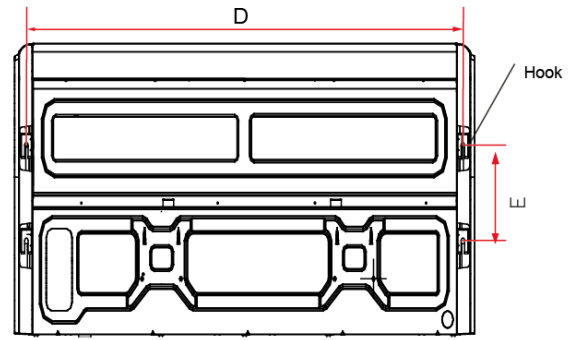

Capacity (Btu/h)		D	E
18K / 24K	mm	983	220
	inch	38.70	8.66
36K	mm	1200	220
	inch	47.24	8.66
48K/60K	mm	1565	220
	inch	61.61	8.66

- ② Wall-mounted installation

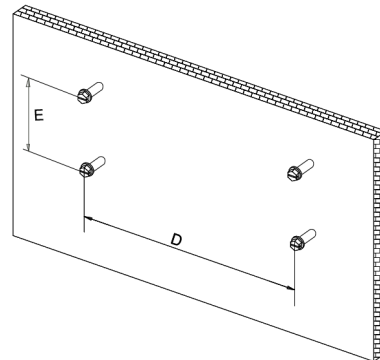

13.2.4.3 Install the pendant bolt

- ① Ceiling installation

Select the position of installation hooks according to the hook holes positions showed in upper picture.

Drill four holes of $\varnothing 12\text{mm}$, 45~50mm deep at the selected positions on the ceiling. Then embed the expansible hooks (fittings).



- ② Wall-mounted installation

Install the tapping screws onto the wall. (Refer to picture below)

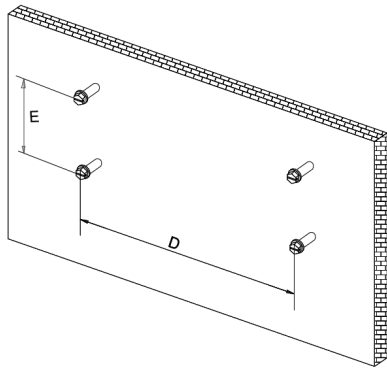

13.2.4.4 Install the main body

① Ceiling installation (The only installation method for the unit with drain pump)
Remove the side board and the grille.

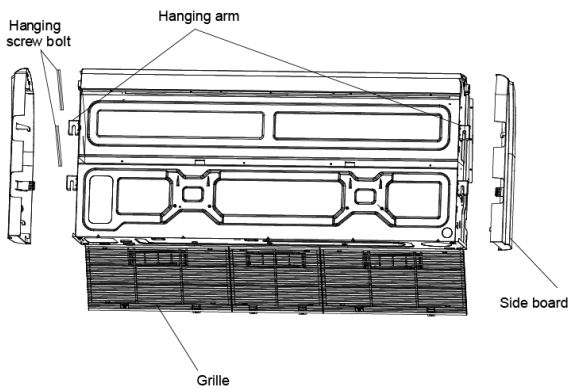

Locate the hanging arm on the hanging screw bolt. Prepare the mounting bolts on the unit.

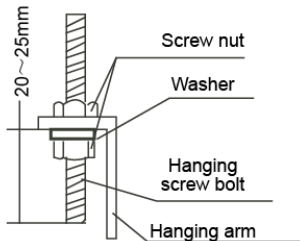

Put the side panels and grilles back.

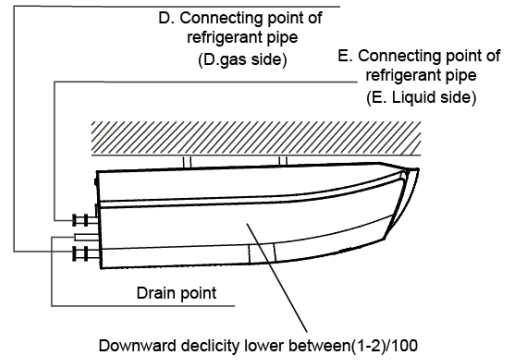
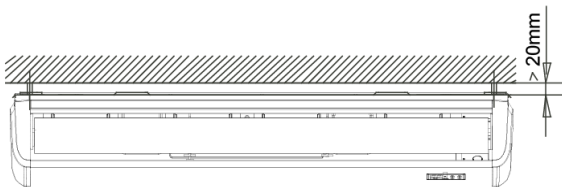

② Wall-mounted installation

Hang the indoor unit by insert the tapping screws into the hanging arms on the main unit. (The bottom of body can touch with floor or suspended, but the body must install vertically.)

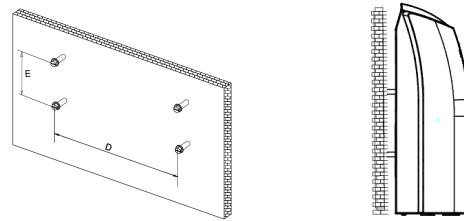

13.2.5 Slim cassette indoor unit installation

13.2.5.1 Service space for indoor unit

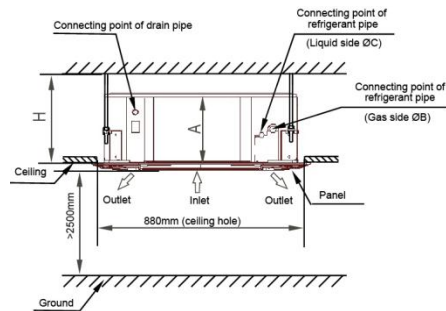
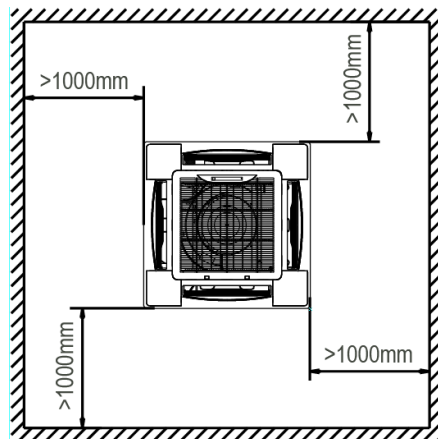

Capacity (Btu/h)		A	H
24K	mm	205	>235
	inch	8.07	>9.25

36K	mm	245	>275
	inch	9.65	>10.83
48K	mm	287	>317
	inch	11.30	>12.48

13.2.5.2 Bolt pitch

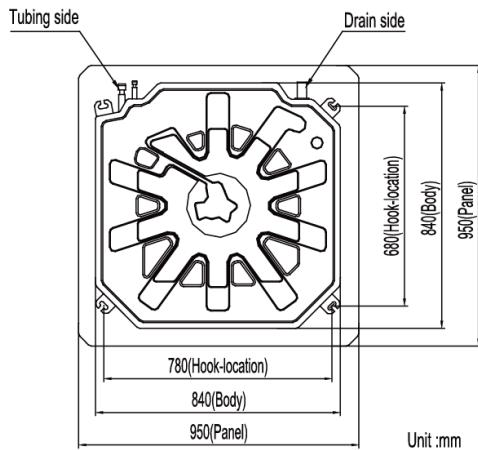

13.2.5.3 Install the pendant bolt

Select the position of installation hooks according to the hook holes positions showed in upper picture.

Drill four holes of $\varnothing 12\text{mm}$, 45~50mm deep at the selected positions on the ceiling. Then embed the expansible hooks (fittings).



13.2.5.4 Install the main body

Make the 4 suspender through the 4 hanger of the main body to suspend it. Adjust the hexangular nuts on the four installation hooks evenly, to ensure the balance of the body. Use a leveling instrument to make sure the levelness of the main body is within $\pm 1^\circ$.



Adjust the position to ensure the gaps between the body and the four sides of ceiling are even. The body's lower part should sink into the ceiling for 10~12 mm. In general, L is half of the screw length of the installation hook.

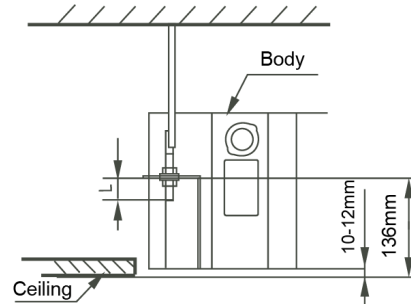

Locate the air conditioner firmly by wrenching the nuts after having adjusted the body's position well.



13.2.5.5 Install the panel

Remove the grille

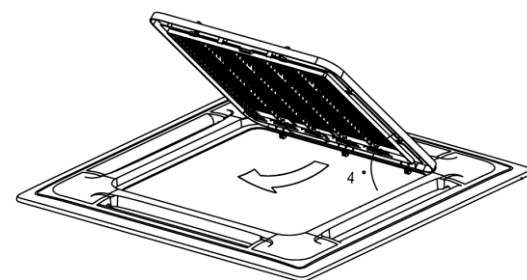
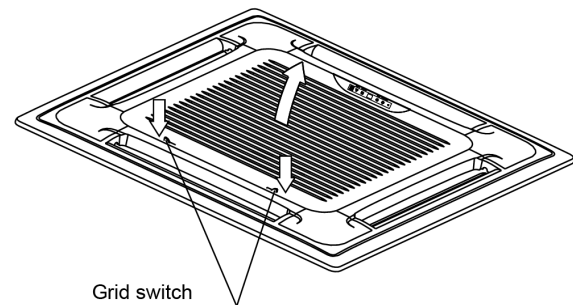

Remove the 4 corner covers.

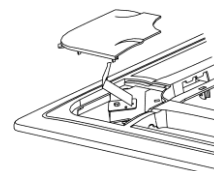

Hang the panel to the hooks on the mainbody. If the panel is with auto-lift grille, please watch the ropes lifing the grille, DO NOT make the ropes entwinded or blocked.

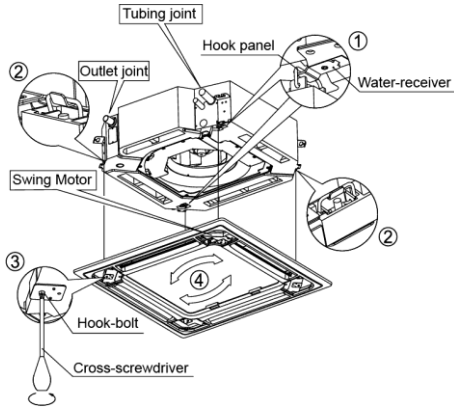

Tighten the screws under the panel hooks till the panel closely stick on the ceiling to avoid condensate water.

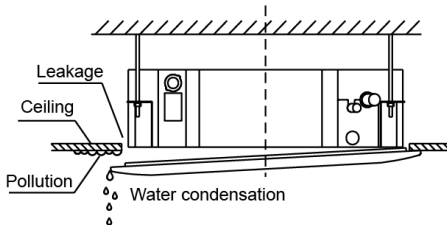
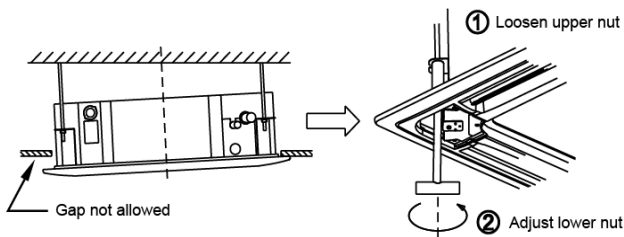

Hang the air-in grille to the panel, then connect the lead terminator of the swing motor and that of the control box with corresponding terminators on the body respectively.

Install the 4 corner covers back.

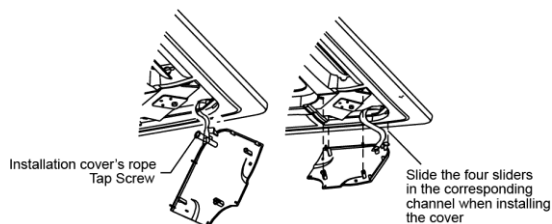

Note: The panel shall be installed after the wiring connected.

13.2.6 HESP duct indoor unit installation

13.2.6.1 Service space for indoor unit

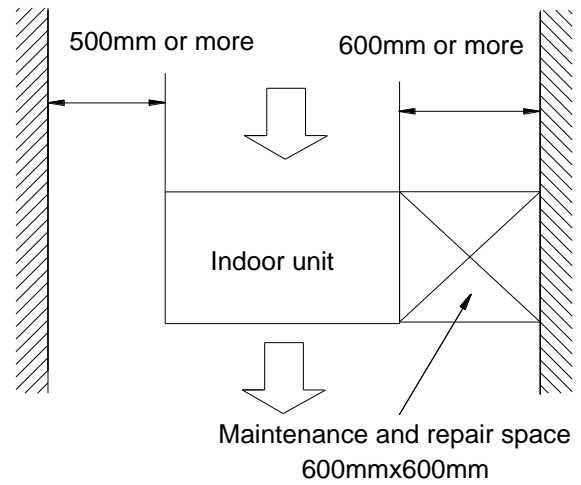

13.2.6.2 Bolt pitch

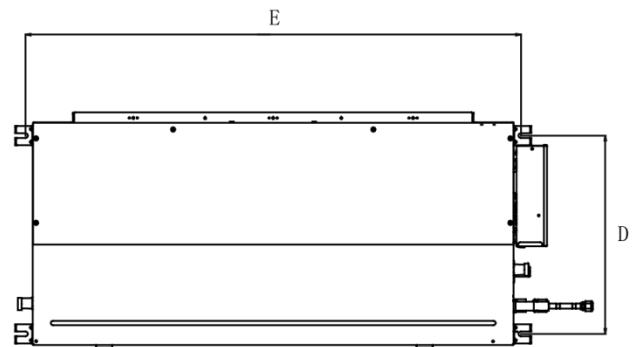

Capacity (KBtu)	Size of mounted lug	
	D	E
60	700	1436

13.2.6.3 Install the pendant bolt

Select the position of installation hooks according to the hook holes positions showed in upper picture.

Drill four holes of $\varnothing 12\text{mm}$, 45~50mm deep at the selected positions on the ceiling. Then embed the expansible hooks (fittings).



13.2.6.4 Install the main body

Make the 4 suspender through the 4 hanger of the main body to suspend it. Adjust the hexangular nuts on the four installation hooks evenly, to ensure the balance of the body. Use a leveling instrument to make sure the levelness of the main body is within $\pm 1^\circ$.

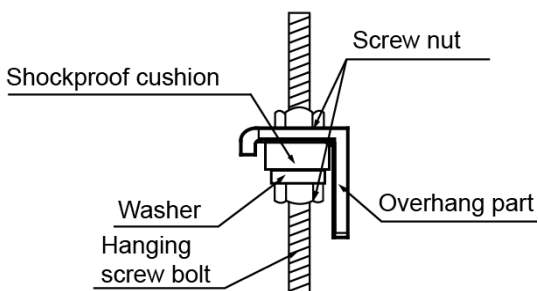

13.2.6.5 Install the air duct

Please design the air duct as below recommended picture

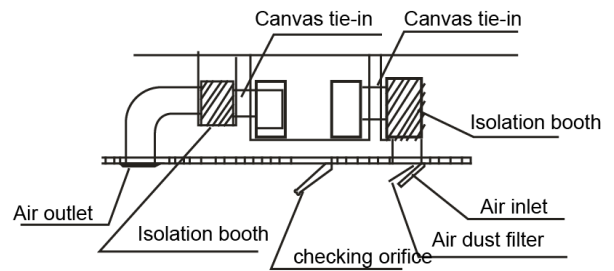

13.3 Outdoor unit installation

13.3.1 Service space for outdoor unit

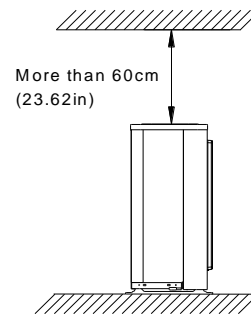
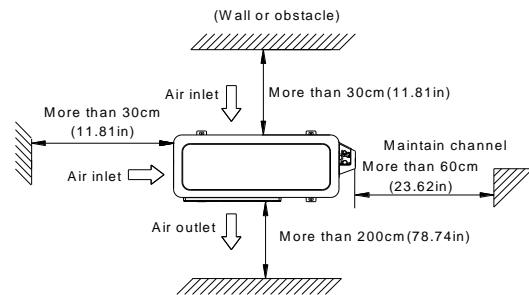

13.3.2 Bolt pitch

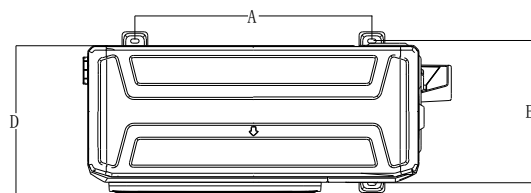

For the value of A, B and D, please refer to the dimension part.

13.3.3 Install the Unit

Since the gravity center of the unit is not at its physical center, so please be careful when lifting it with a sling.

Never hold the inlet of the outdoor unit to prevent it from deforming.

Do not touch the fan with hands or other objects.

Do not lean it more than 45°, and do not lay it sidelong.

Make concrete foundation according to the specifications of the outdoor units.

Fasten the feet of this unit with bolts firmly to prevent it from collapsing in case of earthquake or strong wind.

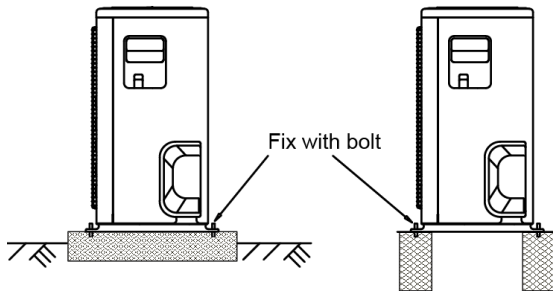

13.4 Refrigerant pipe installation

13.4.1 Maximum pipe length and height drop

Considering the allowable pipe length and height drop to decide the installation position. Make sure the distance and height drop between indoor and outdoor unit not exceeded the data in the following table.

Model	Max. Length		Max. Elevation	
	m	Ft.	m	Ft.
9,000Btu/h	25	82.2	10	32.9
12,000Btu/h	25	82.2	10	32.9
18,000Btu/h	30	98.7	20	65.8
24,000Btu/h	50	164.5	25	82.2
36,000Btu/h	65	213.8	30	98.7
48,000Btu/h	65	213.8	30	98.7

13.4.2 The procedure of connecting pipes

1. Choose the pipe size according to the specification table.
2. Confirm the cross way of the pipes.
3. Measure the necessary pipe length.
4. Cut the selected pipe with pipe cutter
- Make the section flat and smooth.

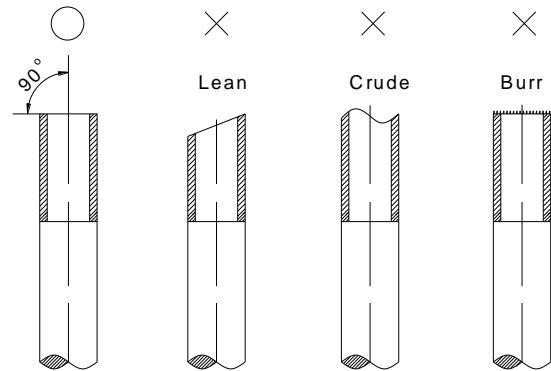

5. Insulate the copper pipe
 - Before test operation, the joint parts should not be heat insulated.
6. Flare the pipe
 - Insert a flare nut into the pipe before flaring the pipe
 - According to the following table to flare the pipe

Pipe diameter	Flare dimension A (mm)		Flare shape
	Min	Max	
1/4" (6.35)	8.3	8.7	
3/8" (9.52)	12.0	12.4	
1/2" (12.7)	15.4	15.8	
5/8" (15.9)	18.6	19.1	
3/4" (19)	22.9	23.3	

- After flared the pipe, the opening part must be seal by end cover or adhesive tape to avoid duct or exogenous impurity come into the pipe.
7. Drill holes if the pipes need to pass the wall.
8. According to the field condition to bend the pipes so that it can pass the wall smoothly.
9. Bind and wrap the wire together with the insulated pipe if necessary.
10. Set the wall conduit
11. Set the supporter for the pipe.
12. Locate the pipe and fix it by supporter

- For horizontal refrigerant pipe, the distance between supporters should not be exceed 1m.
 - For vertical refrigerant pipe, the distance between supporters should not be exceed 1.5m.
13. Connect the pipe to indoor unit and outdoor unit by using two spanners.
- Be sure to use two spanners and proper torque to fasten the nut, too large torque will damage the flare, and too small torque may cause leakage. Refer the following table for different pipe connection.

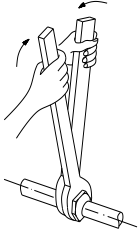
Pipe Diameter	Torque		Sketch map
	(kgf.cm)	(N.cm)	
1/4" (6.35)	144~176	1420~1720	
3/8" (9.52)	333~407	3270~3990	
1/2" (12.7)	504~616	4950~6030	
5/8" (15.9)	630~770	6180~7540	
3/4" (19)	990~1210	9270~11860	

13.4.3 First-Time Installation

Air and moisture in the refrigerant system cause the following problems:

- Increases in system pressure
- Increases in operating current
- Decreases in cooling and heating efficiency
- Blocks in capillary tubing caused by moisture in the refrigerant circuit freezing
- Corrosion of parts in the refrigerant system caused by water

The indoor units and the pipes between indoor and outdoor units must be tested for leakages and evacuated to remove gas and moisture from the system.

Gas leak check with soap water:

Apply soap water or a liquid neutral detergent on the connections with a soft brush to check for leakage in the pipe connecting points. If bubbles emerge, the pipes are leaking.

1. Air Purging Using the Vacuum Pump

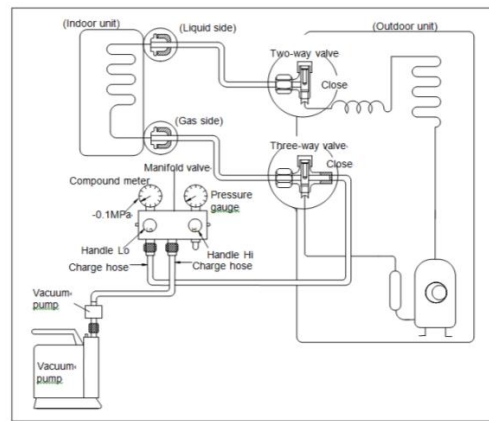

- 1) Completely tighten the flare nuts on the indoor and outdoor units. Confirm that both the 2-way and 3-way valves are set to the closed position.
- 2) Connect the charge hose with the push pin of the Handle Lo to the 3-way valve gas service port.
- 3) Connect the charge hose of the Handle Hi to the vacuum pump.
- 4) Fully open the Handle Lo of the manifold valve.
- 5) Turn on the vacuum pump to begin evacuation.
- 6) Conduct a 30-minute evacuation. Check whether the compound meter indicates -0.1Mpa(14.5Psi). If the meter does not indicate -0.1Mpa(14.5Psi) after 30 minutes has elapsed, continue evacuation for 20 more minutes. If the pressure does not reach -0.1Mpa(14.5Psi) after 50 minutes has elapsed, check if there are any leaks.
Fully close the Handle Lo valve of the manifold valve and turn off the vacuum pump. After 5 minutes, confirm that the gauge needle is not moving.
- 7) Turn the flare nut on the 3-way valve 45° counterclockwise for 6-7 seconds. Once gas begins to come out, tighten the flare nut. Make sure the pressure display on the pressure indicator is higher than atmospheric pressure. Then remove the charge hose from the 3-way valve.
- 8) Fully open the 2-way and 3-way valves and securely tighten the cap on the 3-way valve.

2. Air Purging Using Refrigerant

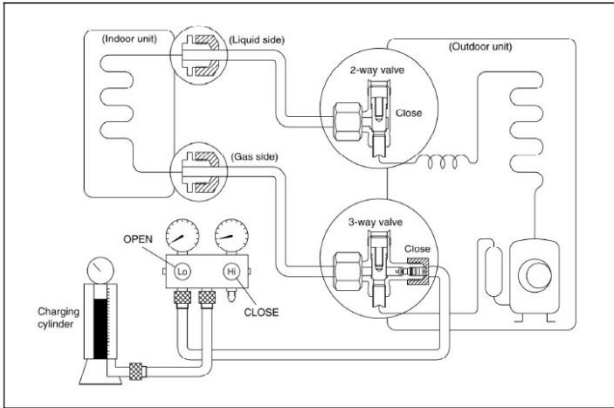

Procedure:

- 1). Confirm that both the 2-way and 3-way valves are set to the closed position.
- 2). Connect the charge set and a charging cylinder to the service port on the 3-way valve.
- 3). Air purging:
Open the valves on the charging cylinder and the charge set. Loosen the flare nut on the 2-way valve approximately 45° for 3 seconds then closing it for 1 minute. Repeat 3 times.
After purging the air, use a torque wrench to tighten the flare nut on the 2-way valve.
- 4). Check for gas leaks.
Check the flare connections for gas leaks.
- 5). Discharge the refrigerant.
Close the valve on the charging cylinder and discharge the refrigerant by loosening the flare nut on the 2-way valve approximately 45° until the gauge displays a value between 0.3 to 0.5 Mpa(43.5 to 72.5Psi)
- 6). Disconnect the charge set and the charging cylinder. Set the 2-way and 3-way valves to the open position.
Be sure to use a hexagonal wrench to open and close the valve stems.
- 7). Mount the valve stems nuts and the service port cap.
Be sure to use a torque wrench to tighten the service port cap to a torque of 18N·m.
Be sure to check for gas leaks.

13.4.4 Adding Refrigerant after Long-Term System Operation

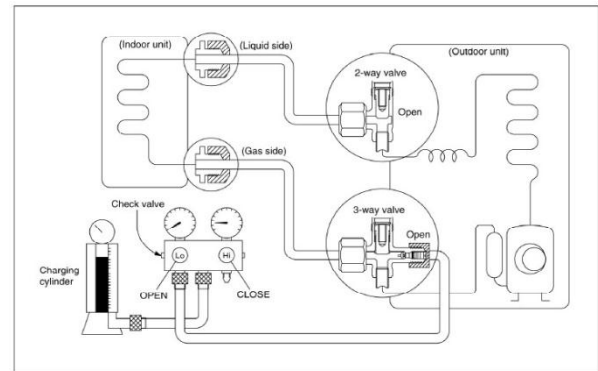

Procedure

- 1). Connect the charge hose to the 3-way service port and open the 2-way and 3-way valve.
Connect the charge hose to the valve at the bottom of the cylinder. If the refrigerant is R410A, place the cylinder bottom-up to ensure liquid charge.
- 2). Purge the air from the charge hose.
Open the valve at the bottom of the cylinder and press the check valve on the charge set to purge the air (be careful of the liquid refrigerant).
- 3) Place the charging cylinder onto the electronic scale and record the weight.
- 4) Turn on the air conditioner in cooling mode.
- 5) Open the valves (Low side) on the charge set and charge the system with liquid refrigerant.
- 6).When the electronic scale displays the proper weight (refer to the gauge and the pressure of the low side), disconnect the charge hose from the 3-way valve's service port immediately and turn off the air conditioner before disconnecting the hose.
- 7). Mount the valve stem caps and the service port.
Use torque wrench to tighten the service port cap to a torque of 18N·m.
Be sure to check for gas leaks.

13.4.5 Re-installation When Indoor Unit Requires Repairs

1. Collecting the Refrigerant into the Outdoor Unit

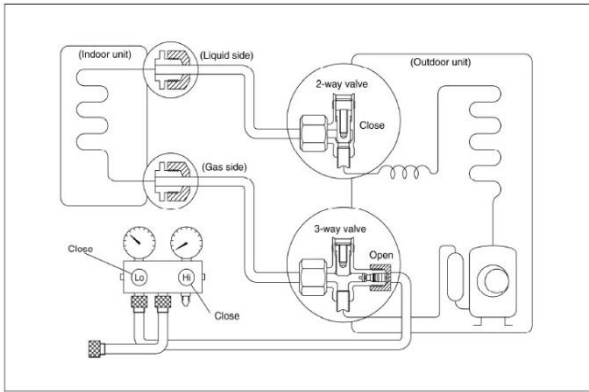

Procedure

- 1). Confirm that both the 2-way and 3-way valves are open.
Remove the valve stem caps and confirm that the valve stems are open.
Be sure to use a hexagonal wrench to operate the valve stems.
- 2). Connect the charge hose with the push pin of handle Lo to the 3-way valves gas service port.
- 3). Purge the air from the charge hose.
Open the handle Lo valve of the manifold valve slightly to purge air from the charge hose for 5 seconds and then close it quickly.
- 4). Close the 2-way valve.
- 5). Turn on the air conditioner in cooling mode.
Turn it off when the gauge indicates -0.1MPa(14.5Psi).
- 6).Immediately close the 3-way valve
Do this quickly so that the gauge displays a value between 0.3 to 0.5 Mpa(43.5 to 72.5Psi).
Disconnect the charge set, and tighten the 2-way and 3-way valves' stem nuts.
Use a torque wrench to tighten the 3-way valves service port cap to a torque of 18N.m.
Be sure to check for gas leaks.

2. Air Purging by the Refrigerant

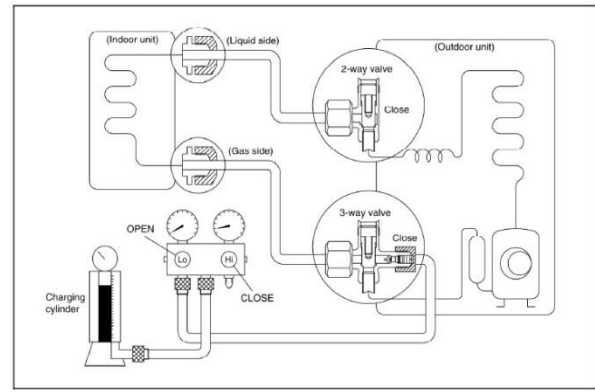

Procedure:

- 1). Confirm that both the 2-way and 3-way valves are closed.
- 2). Connect the charge set and a charging cylinder to the service port of the 3-way valve
Leave the valve on the charging cylinder closed.
- 3). Purge the air from the charge hose.
Open the valves on the charging cylinder and the charge set. Purge the air by loosening the flare nut on the 2-way valve approximately 45' for 3 seconds and then closing it for 1 minute.
Repeat 3 times.
After purging the air, use a torque wrench to tighten the flare nut on the 2-way valve.
- 4). Check for gas leaks
Check the flare connections for gas leakage.
- 5). Discharge the refrigerant.
Close the valve on the charging cylinder and discharge the refrigerant by loosening the flare nut on the 2-way valve approximately 45' until the gauge indicates 0.3 to 0.5 Mpa(43.5 to 72.5Psi)
- 6). Disconnect the charge set and the charging cylinder, and open the 2-way and 3-way valves
Be sure to use a hexagonal wrench to operate the valve stems.
- 7). Mount the valve stems nuts and the service port cap.
Be sure to use a torque wrench to tighten the service port cap to a torque 18N.m.
Be sure to check for gas leakage.

13.4.6 Re-Installation When the Outdoor Unit Requires Repairs

1. Evacuation for the whole system

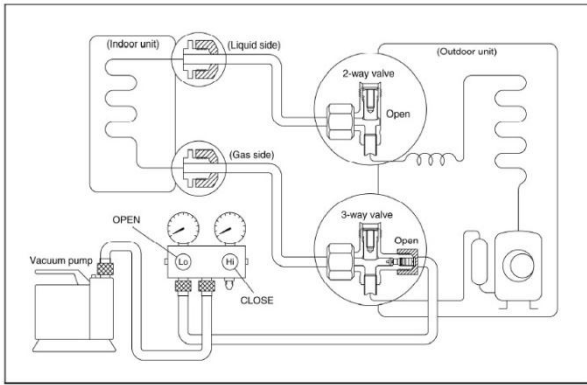

Procedure:

- 1). Confirm that both the 2-way and 3-way valves are open.
- 2). Connect the vacuum pump to 3-way valve's service port.
- 3). Conduct an evacuation for approximately one hour. Confirm that the compound meter displays a value of -0.1Mpa(14.5Psi).
- 4). Close the valve (Low side) on the charge set, turn off the vacuum pump. After 5 minutes, confirm that the gauge needle is not moving.
- 5). Disconnect the charge hose from the vacuum pump.

2. Refrigerant charging

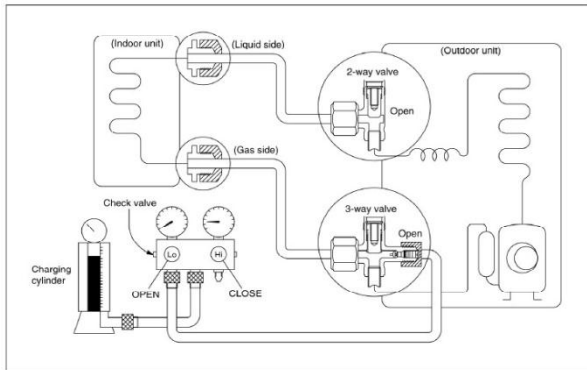

Procedure:

- 1). Connect the charge hose to the charging cylinder. Open the 2-way 3-way valve. With the charge hose you disconnected from the vacuum pump, connect it to the valve at the bottom of the cylinder. If the refrigerant is R410A, place the cylinder bottom-up to ensure liquid charge.
- 2). To purge the air from the charge hose, open the valve at the bottom of the cylinder and press

the check valve on the charge set (be careful of the liquid refrigerant).

- 3) Place the charging cylinder onto the electronic scale and record the weight.
- 4). Open the valves (Low side) on the charge set and charge the system with liquid refrigerant. If the system cannot be charged with the specified amount of refrigerant, or can be charged with a only a small amount at a time (approximately 150g each time), turn the unit on in cooling mode; however, one time is not sufficient, wait approximately 1 minute and then repeat the procedure.
- 5). If the electronic scale displays the proper weight, disconnect the charge hose from the 3-way valve's service port immediately. If the system has been charged with liquid refrigerant while the air conditioner is on, turn off the air conditioner before disconnecting the hose.
- 6). Mount the valve stem caps and the service port. Use a torque wrench to tighten the service port cap to a torque of 18N.m. Be sure to check for gas leakage.

13.5 Drainage pipe installation

Install the drainage pipe as shown below and take measures against condensation. Improperly installation could lead to leakage and eventually wet furniture and belongings.

13.5.1 Installation principle

- Ensure at least 1/100 slope of the drainage pipe
- Adopt suitable pipe diameter
- Adopt nearby condensate water discharge

13.5.2 Key points of drainage water pipe installation

1. **Considering the pipeline route and elevation**
 - Before installing condensate water pipeline, determine its route and elevation to avoid

intersection with other pipelines and ensure slope is straight.

2. Drainage pipe selection

- The drainage pipe diameter shall not small than the drain hose of indoor unit
- According to the water flowrate and drainage pipe slope to choose the suitable pipe, the water flowrate is decided by the capacity of indoor unit.

Relationship between water flowrate and capacity of indoor unit

Capacity (x1000Btu)	Water flowrate (l/h)
12	2.4
18	4
24	6
30	7
36	8
42	10
48	12
60	14

According to the above table to calculate the total water flowrate for the confluence pipe selection.

For horizontal drainage pipe (The following table is for reference)

PVC pipe	Reference value of inner diameter of pipe (mm)	Allowable maximum water flowrate (l/h)		Remark
		Slope 1/50	Slope 1/100	
PVC25	20	39	27	For branch pipe
PVC32	25	70	50	
PVC40	31	125	88	Could be used for confluence pipe
PVC50	40	247	175	
PVC63	51	473	334	

Attention: Adopt PVC40 or bigger pipe to be the main pipe.

For Vertical drainage pipe (The following table is for reference)

PVC pipe	Reference value of inner diameter of pipe (mm)	Allowable maximum water flowrate (l/h)	Remark
PVC25	20	220	For branch pipe
PVC32	25	410	
PVC40	31	730	Could be used

PVC50	40	1440	for confluence pipe
PVC63	51	2760	
PVC75	67	5710	
PVC90	77	8280	

Attention: Adopt PVC40 or bigger pipe to be the main pipe.

3. Individual design of drainage pipe system

- The drainage pipe of air conditioner shall be installed separately with other sewage pipe, rainwater pipe and drainage pipe in building.
- The drainage pipe of the indoor unit with water pump should be apart from the one without water pump.

4. Supporter gap of drainage pipe

- In general, the supporter gap of the drainage pipe horizontal pipe and vertical pipe is respectively 1m~1.5m (3.28~4.92ft) and 1.5m~2.0m(4.95~6.56ft).
- Each vertical pipe shall be equipped with not less than two hangers.
- Overlarge hanger gap for horizontal pipe shall create bending, thus leading to air block.

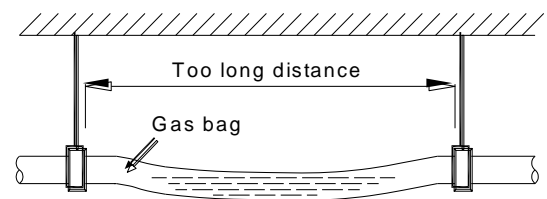

5. The horizontal pipe layout should avoid converse flow or bad flow

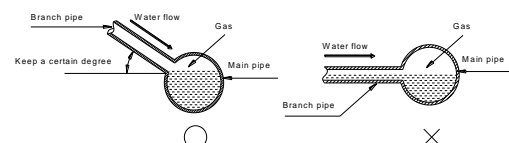
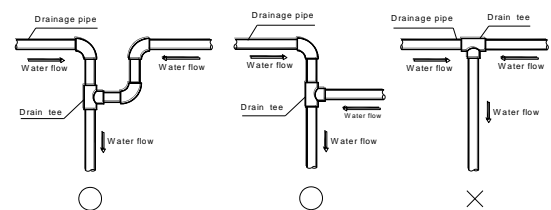

- The correct installation will not cause converse water flow and the slope of the branch pipes can be adjusted freely

- The false installation will cause converse water flow and the slope of the branch pipe cannot be adjusted.

6. Water storage pipe setting

- If the indoor unit has high extra static pressure and without water pump to elevate the condensate water, such as high extra static pressure duct unit, the water storage pipe should be set to avoid converse flow or blow water phenomena.

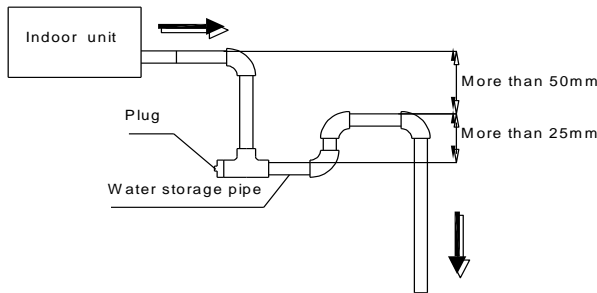

7. Lifting pipe setting of indoor unit with water pump

- The length of lifting pipe should not exceed the pump head of indoor unit water pump.
- The drainage pipe should be set down inclined after the lifting pipe immediately to avoid wrong operation of water level switch.
- Refer the following picture for installation reference.

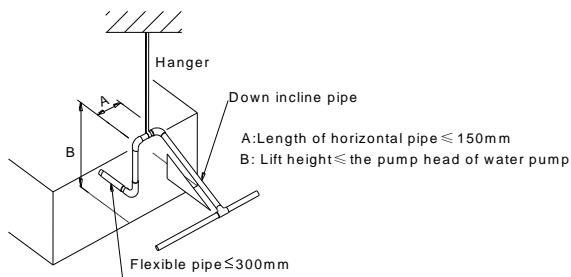

8. Blowhole setting

- For the concentrated drainage pipe system, there should design a blowhole at the highest point of main pipe to ensure the condensate water discharge smoothly.
- The air outlet shall face down to prevent dirt entering pipe.
- Each indoor unit of the system should be installed it.
- The installation should be considering the convenience for future cleaning.

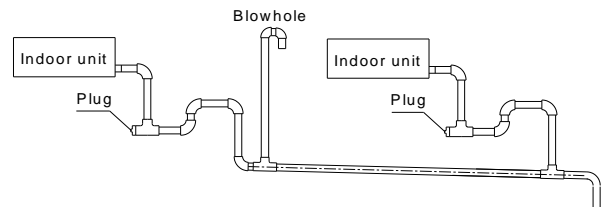

9. The end of drainage pipe shall not contact with ground directly.

13.5.3 Drainage test

13.5.3.1. Water leakage test

After finishing the construction of drainage pipe system, fill the pipe with water and keep it for 24 hours to check whether there is leakage at joint section.

13.5.3.2. Water discharge test

1. Natural drainage mode (the indoor unit with outdoor drainage pump)

Infuse above 600ml water through water test hole slowly into the water collector, observe whether the water can discharge through the transparent hard pipe at drainage outlet.

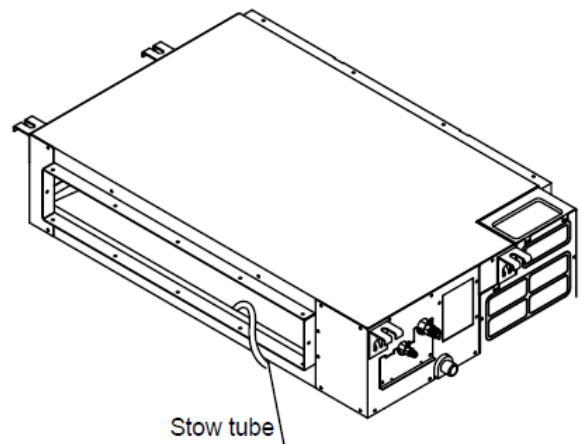

2. Pump drainage mode

2.1 Disconnect the plug of water level switch, remove the cover of water test hole and slowly infuse about 2000ml water through the water test hole, be sure that the water will not touch the motor of drainage pump.

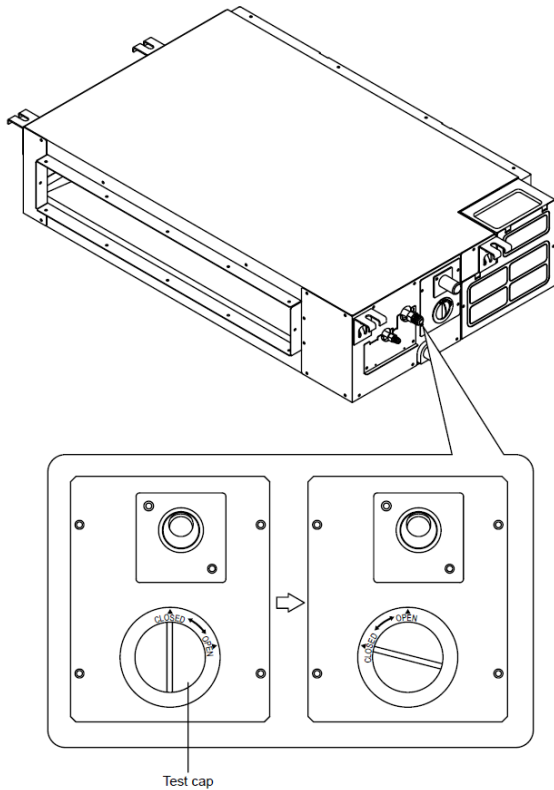

- 2.2 Power on and let the air conditioner operate for cooling. Check operation status of drainage pump, and then connect the plug of water level switch, check the operation sound of water pump and observe whether the water can discharge through the transparent hard pipe at drainage outlet. (In light of the length of drainage pipe, water shall be discharged about 1 minute delayed)
- 2.3 Stop the operation of air conditioner, power off the power supply and put the cover of water test hole back to the original place.
- a. After stopped the air conditioner 3 minutes, check whether there is anything abnormal. If drainage pipes have not been distributed properly, over back-flow water shall cause the flashing of alarm indicator at remote-controlled receiving board and even water shall run over the water collector.

- b. Continuously infusing water until water level alarmed, check whether the drainage pump could discharge water at once. If water level does not decline under warning water level 3 minutes later, it shall cause shutdown of unit. When this situation happens, the normal startup only can be recovered by turning down power supply and eliminating accumulated water.

Note: Drain plug at the main water-containing plate is used for eliminating accumulated water in water-containing plate when maintaining air conditioner fault. During normal operation, the plug shall be filled in to prevent leakage.

13.5.4 Insulation work of drainage pipe

Refer the introduction to the insulation engineering parts.

13.6 Vacuum Drying and Leakage Checking

13.6.1 Purpose of vacuum drying

- Eliminating moisture in system to prevent the phenomena of ice-blockage and copper oxidation.
Ice-blockage shall cause abnormal operation of system, while copper oxide shall damage compressor.
- Eliminating the non-condensable gas (air) in system to prevent the components oxidizing, pressure fluctuation and bad heat exchange during the operation of system.

13.6.2 Selection of vacuum pump

- The ultimate vacuum degree of vacuum pump shall be -756mmHg or above.
- Precision of vacuum pump shall reach 0.02mmHg or above.

13.6.3 Operation procedure for vacuum drying

Due to different construction environment, two kinds of vacuum drying ways could be chosen,

namely ordinary vacuum drying and special vacuum drying.

1 Ordinary vacuum drying

- When conduct first vacuum drying, connect pressure gauge to the infusing mouth of gas pipe and liquid pipe, and keep vacuum pump running for 1hour (vacuum degree of vacuum pump shall be reached -755mmHg).
- If the vacuum degree of vacuum pump could not reach -755mmHg after 1 hour of drying, it indicates that there is moisture or leakage in pipeline system and need to go on with drying for half an hour.
- If the vacuum degree of vacuum pump still could not reach -755mmHg after 1.5 hours of drying, check whether there is leakage source.
- Leakage test: After the vacuum degree reaches -755mmHg, stop vacuum drying and keep the pressure for 1 hour. If the indicator of vacuum gauge does not go up, it is qualified. If going up, it indicates that there is moisture or leak source.

2 Special vacuum drying

The special vacuum drying method shall be adopted when:

- Finding moisture during flushing refrigerant pipe.
- Conducting construction on rainy day, because rain water might penetrated into pipeline.
- Construction period is long, and rain water might penetrated into pipeline.
- Rain water might penetrate into pipeline during construction.

Procedures of special vacuum drying are as follows:

- Vacuum drying for 1 hour.
- Vacuum damage, filling nitrogen to reach 0.5Kgf/cm2 .
Because nitrogen is dry gas, vacuum damage could achieve the effect of vacuum drying, but this method could not achieve drying thoroughly when there is too much moisture. Therefore, special attention shall be drawn to prevent the entering of water and the formation of condensate water.
- Vacuum drying again for half an hour.
If the pressure reaches -755mmHg, start to pressure leakage test. If it cannot reach the value, repeat vacuum damage and vacuum drying again for 1 hour.
- Leakage test: After the vacuum degree reaches -755mmHg, stop vacuum drying and keep the pressure for 1 hour. If the indicator of vacuum gauge does not go up, it is qualified. If going up, it indicates that there is moisture or leak source.

13.7 Additional refrigerant charge

- After the vacuum drying process is carried out, the additional refrigerant charge process needs to be performed.
- The outdoor unit is factory charged with refrigerant. The additional refrigerant charge volume is decided by the diameter and length of the liquid pipe between indoor and outdoor unit. Refer the following formula to calculate the charge volume.

Diameter of liquid pipe (mm)	Φ6.35	Φ9.52
Formula	$V=15g/m \times (L-7.5)$	$V=30g/m \times (L-7.5)$

V: Additional refrigerant charge volume (g).

L: The length of the liquid pipe (m).

Note:

- Refrigerant may only be charged after performed the vacuum drying process.
- Always use gloves and glasses to protect your hands and eyes during the charge work.
- Use electronic scale or fluid infusion apparatus to weight refrigerant to be recharged. Be sure to avoid extra refrigerant charged, it may cause liquid hammer of the compressor or protections.
- Use supplementing flexible pipe to connect refrigerant cylinder, pressure gauge and outdoor unit. And The refrigerant should be charged in liquid state. Before recharging, The air in the flexible pipe and manifold gauge should be exhausted.
- After finished refrigerant recharge process, check whether there is refrigerant leakage at the connection joint part. (Using gas leakage detector or soap water to detect).

13.8 Engineering of insulation

13.8.1 Insulation of refrigerant pipe

1 Operational procedure of refrigerant pipe insulation

Cut the suitable pipe → insulation (except joint section) → flare the pipe → piping layout and connection → vacuum drying → insulate the joint parts

2 Purpose of refrigerant pipe insulation

- During operation, temperature of gas pipe and liquid pipe shall be over-heating or over-cooling extremely. Therefore, it is necessary to carry out insulation; otherwise it shall debase the performance of unit and burn compressor.
- Gas pipe temperature is very low during cooling. If insulation is not enough, it shall form dew and cause leakage.
- Temperature of gas pipe is very high (generally 50-100 °C) during heating. Insulation work must be carried out to prevent hurt by carelessness touching.

3 Insulation material selection for refrigerant pipe

- The burning performance should over 120°C
- According to the local law to choose insulation materials
- The thickness of insulation layer shall be above 10mm. If in hot or wet environment place, the layer of insulation should be thicker accordingly.

4 Installation highlights of insulation construction

- Gas pipe and liquid pipe shall be insulated separately, if the gas pipe and liquid pipe were insulated together; it will decrease the performance of air conditioner.

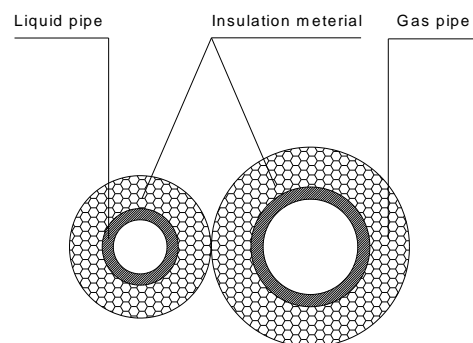

- The insulation material at the joint pipe shall be 5~10cm longer than the gap of the insulation material.
- The insulation material at the joint pipe shall be inserted into the gap of the insulation material.
- The insulation material at the joint pipe shall be banded to the gap pipe and liquid pipe tightly.
- The linking part should be use glue to paste together
- Be sure not bind the insulation material over-tight, it may extrude out the air in the material to cause bad insulation and cause easy aging of the material.

13.8.2 Insulation of drainage pipe

1 Operational procedure of refrigerant pipe insulation

Select the suitable pipe → insulation (except joint section) → piping layout and connection → drainage test → insulate the joint parts

2 Purpose of drainage pipe insulation

The temperature of condensate drainage water is very low. If insulation is not enough, it shall form dew and cause leakage to damage the house decoration.

3 Insulation material selection for drainage pipe

- The insulation material should be flame retardant material, the flame retardancy of the material should be selected according to the local law.
- Thickness of insulation layer is usually above 10mm.
- Use specific glue to paste the seam of insulation material, and then bind with adhesive tape. The width of tape shall not be less than 5cm. Make sure it is firm and avoid dew.

4 Installation and highlights of insulation construction

- The single pipe should be insulated before connecting to another pipe, the joint part should be insulated after the drainage test.
- There should be no insulation gap between the insulation material.

13.9 Engineering of electrical wiring

1 Highlights of electrical wiring installation

- All field wiring construction should be finished by qualified electrician.
- Air conditioning equipment should be grounded according to the local electrical regulations.
- Current leakage protection switch should be installed.
- Do not connect the power wire to the terminal of signal wire.
- When power wire is parallel with signal wire, put wires to their own wire tube and remain at least 300mm gap.
- According to table in indoor part named "the specification of the power" to choose the wiring, make sure the selected wiring not small than the date showing in the table.
- Select different colors for different wire according to relevant regulations.

- Do not use metal wire tube at the place with acid or alkali corrosion, adopt plastic wire tube to replace it.
- There must be not wire connect joint in the wire tube If joint is a must, set a connection box at the place.
- The wiring with different voltage should not be in one wire tube.
- Ensure that the color of the wires of outdoor and the terminal No. are same as those of indoor unit respectively.

13.10 Test operation

1 The test operation must be carried out after the entire installation has been completed.

2 Please confirm the following points before the test operation.

- The indoor unit and outdoor unit are installed properly.
- Tubing and wiring are correctly completed.
- The refrigerant pipe system is leakage-checked.
- The drainage is unimpeded.
- The ground wiring is connected correctly.
- The length of the tubing and the added stow capacity of the refrigerant have been recorded.
- The power voltage fits the rated voltage of the air conditioner.
- There is no obstacle at the outlet and inlet of the outdoor and indoor units.
- The gas-side and liquid-side stop valves are both opened.
- The air conditioner is pre-heated by turning on the power.

3 Test operation

Set the air conditioner under the mode of "COOLING" by remote controller, and check the following points.

Indoor unit

- Whether the switch on the remote controller works well.
- Whether the buttons on the remote controller works well.
- Whether the air flow louver moves normally.
- Whether the room temperature is adjusted well.
- Whether the indicator lights normally.
- Whether the temporary buttons works well.

- Whether the drainage is normal.
- Whether there is vibration or abnormal noise during operation.

Outdoor unit

- Whether there is vibration or abnormal noise during operation.
- Whether the generated wind, noise, or condensed of by the air conditioner have influenced your neighborhood.
- Whether any of the refrigerant is leaked.

14. Operation Characteristics

Temperature Mode	Cooling operation	Heating operation	Drying operation
Room temperature	17°C ~ 32°C (62°F ~ 90°F)	0°C ~ 30°C (32°F ~ 86°F)	10°C ~ 32°C (50°F ~ 90°F)
Outdoor temperature (Entry level)	0°C ~ 50°C (32°F ~ 122°F) (-15°C ~ 50°C (5°F ~ 122°F) : For the models with low temperature cooling system)	-15°C ~ 30°C (5°F ~ 86°F)	0°C ~ 50°C (32°F ~ 122°F)
Outdoor temperature (E-Star level)	-25°C ~ 50°C (-13°F ~ 122°F)	-25°C ~ 30°C (-13°F ~ 86°F)	
Outdoor temperature (Hyper heat)	-30°C ~ 50°C (-22°F ~ 122°F)	-30°C ~ 50°C (-22°F ~ 122°F)	

CAUTION:

1. If the air conditioner is used beyond the above conditions, certain safety protection features may come into operation and cause the unit to operate abnormally.
2. The room relative humidity should be less than 80%. If the air conditioner operates beyond this figure, the surface of the air conditioner may attract condensation. Please set the vertical air flow louver to its maximum angle (vertically to the floor), and set HIGH fan mode.
3. The optimum performance will be achieved during this operating temperature zone.

15. Electronic Function

15.1 Abbreviation

- T1: Indoor room temperature
- T2: Coil temperature of indoor heat exchanger
- T3: Coil temperature of condenser
- T4: Outdoor ambient temperature
- T5: Compressor discharge temperature
- Td: Target temperature

15.2 Display function

15.2.1 Icon explanation on indoor display board (Duct)

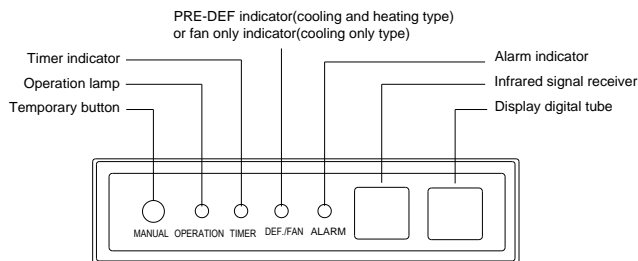

15.2.2 Icon explanation on indoor display board (Compact cassette).

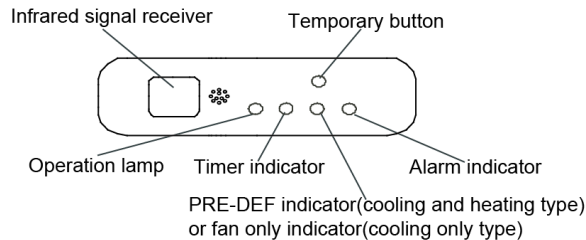

15.2.3 Icon explanation on indoor display board (slim Cassette).

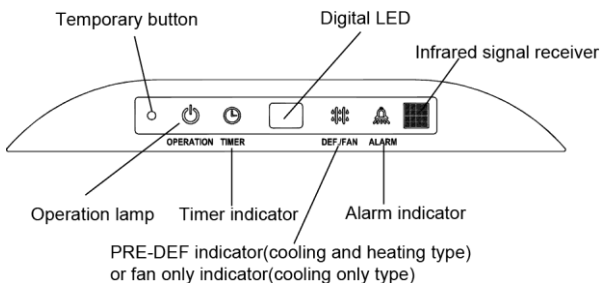

15.2.4 Icon explanation on indoor display board (Console).

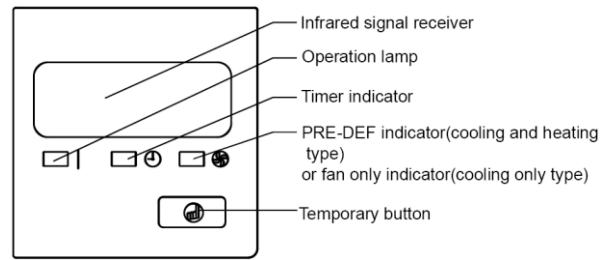

15.2.5 Icon explanation on indoor display board (Ceiling Floor)

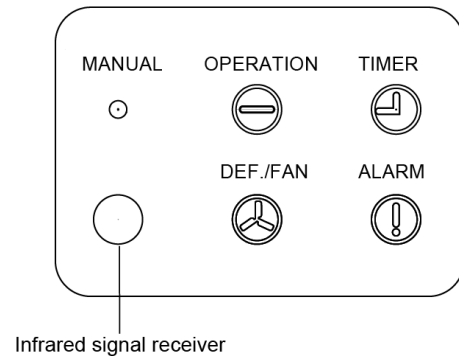

15.3 Main Protection

15.3.1 Three minutes delay at restart for compressor

1 minute delay for the 1st time stand-up and 3 minutes delay for others.

15.3.2 Temperature protection of compressor top

The unit will stop working when the compressor top temp. protector cut off, and will restart after the compressor top temp. protector restart.

15.3.3 Temperature protection of compressor discharge

When the compressor discharge temp. is getting higher, the running frequency will be limited as below rules:

---Compressor discharge temp. $T5 > 115\text{ }^{\circ}\text{C}$ (239°F) for 5s, compressor stops and restarts up till $T5 < 90\text{ }^{\circ}\text{C}$ (194°F)

--- $110 < T5 < 115\text{ }^{\circ}\text{C}$ (239°F), decrease the frequency to the lower level every 2 minutes.

--- $105(221\text{ }^{\circ}\text{F}) < T5 < 110\text{ }^{\circ}\text{C}$ (230°F), keep running at the current frequency.

---- $T5 < 105\text{ }^{\circ}\text{C}$ (221°F), no limit for frequency.

15.3.4 Fan speed malfunction

When indoor fan speed keeps too low (lower than 300RPM) for 50s, the indoor fan will shut

off and restart 30s later, if protection happened 3 times when fan motor restarts continuously, the unit will stop and the LED will display the failure.

When outdoor fan speed keeps too low (lower than 100RPM) or too high (higher than 1500RPM) for 60s, the unit will stop and the LED will display the failure. Malfunction is cleared 30s later.

For A6 Duct& HESP Duct:

If a fault occurs on the air volume regulator or the regulator enters protection mode, it sends the error message CF and an instruction to reduce fan speed to the master. The message and the instruction can be inquired with the remote controller or the wired controller. (Fault and protection information are displayed for one minute). After a fault occurs, the master unit shows the error code E3 and the fault count for one minute. If the fault occurs three times, then the fan is unable to resolve the problem independently. External shutdown by a remote controller, wired controller, or central controller must be used to clear the fan fault and fault count. The fan runs normally for 5 minutes while clearing fault count.

0: No malfunction
1:P0 Overcurrent
2:Overpressure
3:Overload
4:Overspeed
5:Startup malfunction
6:Lack of phase
7:DC voltage too low
8:Communication fault
9:Parameter fault
10:L3 Current limited
11:L5 Voltage limited
12:Target speed cannot be met during the static pressure calculation process.

15.3.5 Inverter module protection

The Inverter module has a protection function about current, voltage and temperature. If these protections happen, the corresponding code will display on indoor unit and the unit will stop working.

15.3.6 Indoor fan delayed open function

When the unit starts up, the louver will be active immediately and the indoor fan will open 7s later.

If the unit runs in heating mode, the indoor fan will be also controlled by anti-cold wind function.

15.3.7 Compressor preheating functions

Preheating permitting condition:

If $T4 < 3^{\circ}\text{C}$ (37.4°F) and the machine connects to power supply newly within 5 seconds or if $T4 < 3^{\circ}\text{C}$ (37.4°F) and compressor has stopped for over 3 hours, the compressor heating cable will work.

Preheating mode:

A weak current flow through the coil of compressor from the wiring terminal of the compressor, then the compressor is heated without operation.

Preheating release condition:

If $T4 \geq 5^{\circ}\text{C}$ (41°F) or the compressor starts running, the preheating function will stop.

15.3.9 Condenser high temperature T3 protection

-- 55°C (131°F) $< T3 < 60^{\circ}\text{C}$ (140°F), the compressor frequency will decrease to the lower level until to F1 and then runs at F1. If $T3 < 54^{\circ}\text{C}$ (129.2°F), the compressor will keep running at the current frequency.

-- $T3 < 52^{\circ}\text{C}$ (125.6°F), the compressor will not limit the frequency and resume to the former frequency.

--- $T3 > 60^{\circ}\text{C}$ (140°F) for 5 seconds, the compressor will stop until $T3 < 52^{\circ}\text{C}$ (125.6°F).

15.3.10 Evaporator low temperature T2 protection

-- $T2 < 0^{\circ}\text{C}$ (32°F), the compressor will stop and restart when $T2 \geq 5^{\circ}\text{C}$ (41°F).

--- 0°C (32°F) $\leq T2 < 4^{\circ}\text{C}$ (39.2°F), the compressor frequency will be limited and decreased to the lower level

--- $4^{\circ}\text{C}(39.2^{\circ}\text{F})\leq T_2\leq 7^{\circ}\text{C}(44.6^{\circ}\text{F})$, the compressor will keep the current frequency.
 --- $T_2>7^{\circ}\text{C}(44.6^{\circ}\text{F})$, the compressor frequency will not be limited.

15.4 Operation Modes and Functions

15.4.1 Fan mode

- (1) Outdoor fan and compressor stop.
- (2) Temperature setting function is disabled, and no setting temperature is displayed.
- (3) Indoor fan can be set to high/med/low/auto.
- (4) The louver operates same as in cooling mode.
- (5) Auto fan:

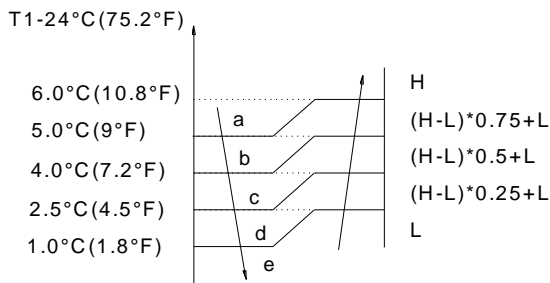

15.4.2 Cooling Mode

15.4.2.1 Outdoor fan running rules

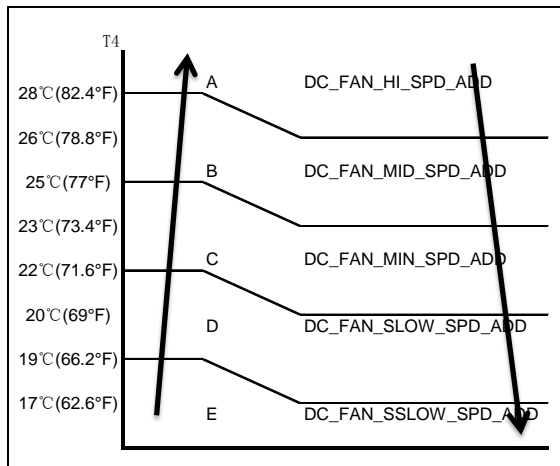

15.4.2.2 Indoor fan running rules

In cooling mode, indoor fan runs all the time and the speed can be selected as high, medium, low and auto.

The indoor fan is controlled as below:

Setting fan speed	T1-Td °C(°F)	Actual fan speed
H	4.5(8.1)	H+ (H+=H+G)
	3.0(5.4)	H (=H)
	1.5(2.7)	H- (H-=H-G)
M	4.5(8.1)	M+ (M+=M+Z)
	3.0(5.4)	M(M=M)
	1.5(2.7)	M- (M-=M-Z)
L	4.5(8.1)	L+ (L+=L+D)
	3.0(5.4)	L(L=L)
	1.5(2.7)	L- (L-=L-D)

Auto fan in cooling mode acts as follow:

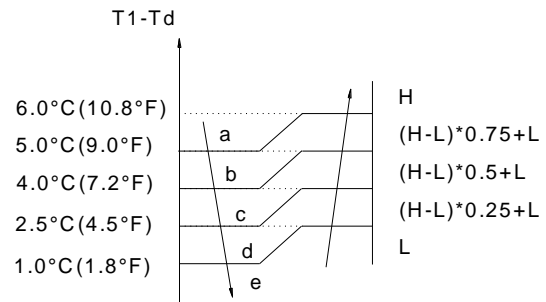

15.4.3 Heating Mode

15.4.3.1 Outdoor fan running rules

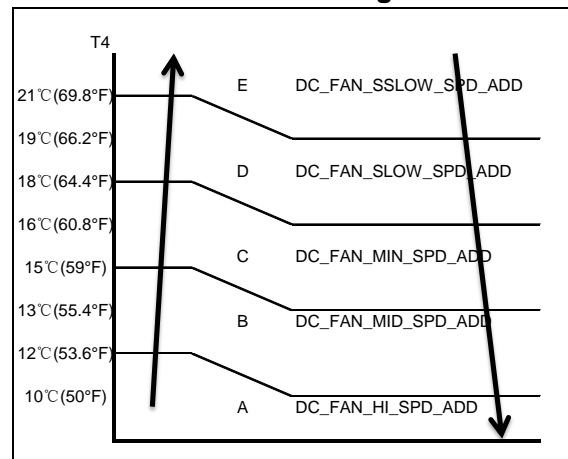

15.4.3.2 Indoor fan running rules

When the compressor is on, the indoor fan can be set to high/med/low/auto. And the anti-cold wind function has the priority.

The indoor fan is controlled as below:

Setting fan speed	T1-Td+1.5 °C(34.7°F)	Actual fan speed
H	-1.5(-2.7° F)	H- (H-=H+G)
	-3.0(-4.8° F)	H (=H)
	-4.5(-8.1° F)	H+(H+=H+G)
M	-1.5(-2.7° F)	M- (M-=M-Z)
	-3.0(-4.8° F)	M(M=M)
	-4.5(-8.1° F)	M+(M+=M+Z)
L	-1.5(-2.7° F)	L- (L-=L-D)
	-3.0(-4.8° F)	L(L=L)
	-4.5(-8.1° F)	L+(L+=L+D)

Auto fan action in heating mode:

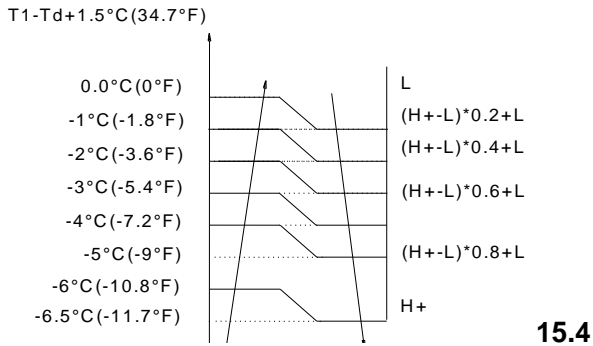

3.3 Defrosting mode

If any one of the following items is satisfied, AC will enter the defrosting mode.

After the compressor starts up and keeps running, mark the minimum value of T3 from the 10th minutes to 15th minutes as T30.

- 1) If the compressor cumulate running time is up to 29 minutes and $T3 < TCDI1$, $T3 + T30SUBT3ONE \leq T30$.
- 2) If the compressor cumulate running time is up to 35 minutes and $T3 < TCDI2$, $T3 + T30SUBT3TWO \leq T30$.
- 3) If the compressor cumulate running time is up to 29 minutes and $T3 < TCDI3$ for 3 minutes.
- 4) If the compressor cumulate running time is up to 120 minutes and $T3 < -15^{\circ}\text{C} (5^{\circ}\text{F})$.

Condition of ending defrosting:

If any one of the following items is satisfied, the defrosting will finish and the machine will turn to normal heating mode.

- T3 rises to be higher than TCDE1.
- T3 keeps to be higher than TCDE2 for 80 seconds.
- The machine has run for 10 minutes in defrosting mode.

Defrosting action:

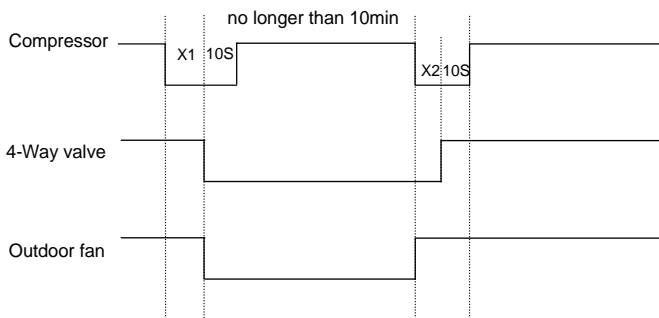

15.4.3.5 Evaporator coil temperature protection

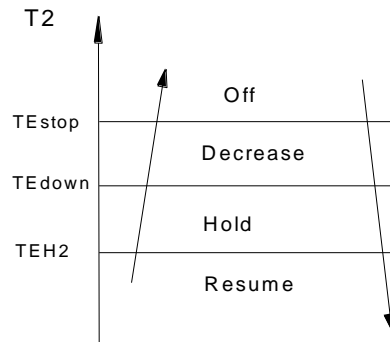

Off: Compressor stops.

Decrease: Decrease the running frequency to the lower level.

Hold: Keep the current frequency.

Resume: No limitation for frequency.

15.4.4 Auto-mode

This mode can be chosen with remote controller and the setting temperature can be changed between $17\sim 30^{\circ}\text{C} (63\sim 86^{\circ}\text{F})$.

In auto mode, the machine will choose cooling, heating or fan-only mode according to ΔT ($\Delta T = T1 - Ts$).

$\Delta T = T1 - Ts$	Running mode
$\Delta T > 2^{\circ}\text{C} (3.6^{\circ}\text{F})$	Cooling
$-2^{\circ}\text{C} (-3.6^{\circ}\text{F}) \leq \Delta T \leq 2^{\circ}\text{C} (3.6^{\circ}\text{F})$	Fan-only
$\Delta T < -2^{\circ}\text{C} (-3.6^{\circ}\text{F})$	Heating

Indoor fan will run at auto fan of the relevant mode.

The louver operates same as in relevant mode. If the machine switches mode between heating and cooling, the compressor will keep stopping for 15 minutes and then choose mode according to $T1 - Ts$.

If the setting temperature is modified, the machine will choose running function again.

15.4.5 Drying mode

Drying mode works the same as cooling mode in breeze speed.

All protections are active and the same as that in cooling mode.

15.4.6 Timer function

15.4.6.1 Timing range is 24 hours.

15.4.6.2 Timer on. The machine will turn on automatically when reaching the setting time.

15.4.6.3 Timer off. The machine will turn off automatically when reaching the setting time.

15.4.6.4 Timer on/off. The machine will turn on automatically when reaching the setting "on" time, and then turn off automatically when reaching the setting "off" time.

15.4.6.5 Timer off/on. The machine will turn off automatically when reaching the setting "off" time, and then turn on automatically when reaching the setting "on" time.

15.4.6.6 The timer function will not change the AC current operation mode. Suppose AC is off now, it will not start up firstly after setting the "timer off" function. And when reaching the setting time, the timer LED will be off and the AC running mode has not been changed.

15.4.6.7 The setting time is relative time.

15.4.7 Sleep function mode

15.4.7.1 The sleep function is available in cooling, heating or auto mode.

15.4.7.2. Operation process in sleep mode is as follow:

When cooling, the setting temperature rises 1°C (1.8°F) (be lower than 30°C(86°F)) every one hour, 2 hours later the setting temperature stops rising and the indoor fan is fixed at low speed.

When heating, the setting temperature decreases 1°C (1.8°F) (be higher than 17°C (62.6°F)) every one hour, 2 hours later the setting temperature stops rising and indoor fan is fixed at low speed. (Anti-cold wind function has the priority).

15.4.7.3 Operation time in sleep mode is 7 hours. After 7 hours, the unit does not switch off, but for console, the unit switches off.

15.4.7.4 Timer setting is available.

15.4.8 Auto-Restart function

The indoor unit is equipped with auto-restart function, which is carried out through an auto-restart module. In case of a sudden power

failure, the module memorizes the setting conditions before the power failure. The unit will resume the previous operation setting (not including sleep function) automatically after 3 minutes when power returns.

15.4.9 Follow me

1) If the indoor PCB receives the signal which results from pressing the FOLLOW ME button on remote controller or wired remote controller, the buzzer will emit a sound and this indicates the follow me function is initiated. But when the indoor PCB receives signal which sent from remote controller every 3 minutes, the buzzer will not respond. When the unit is running with follow me function, the PCB will control the unit according to the temperature from follow me signal, and the temperature collection function of room temperature sensor will be shielded.

2) When the follow me function is available, the PCB will control the unit according to the room temperature from the remote controller and the setting temperature.

3) The PCB will take action to the mode change information from remote controller signal, but it will not be affected by the setting temperature.

4) When the unit is running with follow me function, if the PCB doesn't receive any signal from remote controller for 7 minutes or pressing FOLLOW ME button again, the follow me function will be turned off automatically, and the temperature will control the unit according to the room temperature detected from its own room temperature sensor and setting temperature.

15.4.10 8°C Heating(optional)

In heating operation, the preset temperature of the air conditioner can be as low as 8°C (46.4°F), which keeps the room temperature steady at 8°C(46.4°F) and prevents household things freezing when the house is unoccupied for a long time in severe cold weather.

15.4.11 Drain pump control

Adopt the water-level switch to control the action of drain pump.

Main action under different condition :(every 5 seconds the system will check the water level one time)

1. When the A/C operates with cooling (including auto cooling), dehumidifying, and forced cooling mode, the pump will start running immediately and continuously, till stop cooling.

2. Once the water level increase and up to the control point, LED will alarm and the drain pump open and continue checking the water level. If the water level fall down and LED disarmed (drain pump delay close 1 minute) and operate with the last mode. Otherwise the entire system stop operating (including the pump) and LED remain alarming after 3 minutes,

15.4.12 Point check function

Press the LED DISPLAY or LED or MUTE button of the remote controller three times, and then press the AIR DIRECTION or SWING button three times in ten seconds, the buzzer will keep ring for two seconds. The air conditioner will enter into the information enquiry status. You can press the LED DISPLAY or AIR DIRECTION button to check the next or front item's information.

When the AC enter the "information enquiry" status, it will display the code name in 2 seconds, the details are as follows.

Enquiry information	Displaying code	Meaning
T1	T1	T1 temp.
T2	T2	T2 temp.
T3	T3	T3 temp.
T4	T4	T4 temp.
T2B	Tb	T2B temp.
TP	TP	TP temp.
TH	TH	TH temp.
Targeted Frequency	FT	Targeted Frequency
Actual Frequency	Fr	Actual Frequency
Indoor fan speed	IF	Indoor fan speed
Outdoor fan speed	OF	Outdoor fan speed
EXV opening angle	LA	EXV opening angle
Compressor continuous running time	CT	Compressor continuous running time
Causes of compressor stop.	ST	Causes of compressor stop.
Reserve	A0	
Reserve	A1	
Reserve	b0	
Reserve	b1	
Reserve	b2	
Reserve	b3	
Reserve	b4	
Reserve	b5	
Reserve	b6	
Reserve	dL	
Reserve	Ac	
Reserve	Uo	
Reserve	Td	

When the AC enter into the information enquiry status, it will display the code value in the next 25s, the details are as follows.

Enquiry information	Display value	Meaning	Remark
T1,T2,T3,T4, T2B,TP,TH, Targeted Frequency, Actual Frequency	-1F,-1E,-1d,-1c,- 1b,-1A	-25,-24,-23,-22,-21,-2 0	1. All the displaying temperature is actual value. 2. All the temperature is °C no matter what kind of remote controller is used. 3. T1,T2,T3,T4,T2B display range:-25~70, TP display range:-20~130. 4. Frequency display range: 0~159HZ. 5. If the actual value exceeds the range, it will display the maximum value or minimum value.
	-19—99	-19—99	
	A0,A1,...A9	100,101,...109	
	b0,b1,...b9	110,111,...119	
	c0,c1,...c9	120,121,...129	
	d0,d1,...d9	130,131,...139	
	E0,E1,...E9	140,141,...149	
	F0,F1,...F9	150,151,...159	
Indoor fan speed /Outdoor fan speed	0	OFF	
	1,2,3,4	Low speed, Medium speed, High speed, Turbo	For some big capacity motors.
	14-FF	Actual fan speed=Display value turns to decimal value and then multiply 10. The unit is RPM.	For some small capacity motors, display value is from 14-FF(hexadecimal), the corresponding fan speed range is from 200-2550RPM.
EXV opening angle	0-FF	Actual EXV opening value=Display value turns to decimal value and then multiply 2.	
Compressor continuous running time	0-FF	0-255 minutes	If the actual value exceeds the range, it will display the maximum value or minimum value.
Causes of compressor stop.	0-99	For the detailed meaning, please consult with engineer	Decimal display
Reserve	0-FF		

16. Troubleshooting

Safety

Electricity is stored in capacitors, even when the power supply is shut off. Do not forget to discharge the electricity in the capacitors.

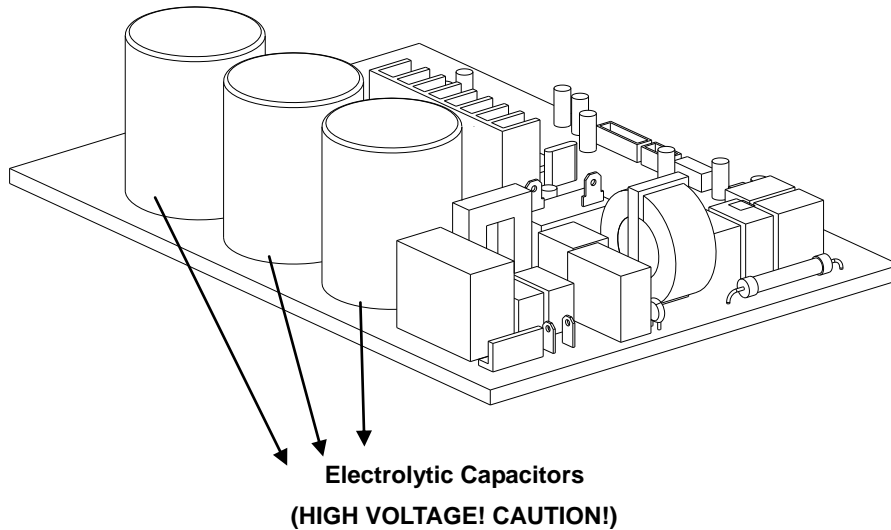

For other models, For other models, connect a discharge resistor (approx. 100Ω 40W) or a soldering iron plug between the + and - terminals of the electrolytic capacitor on the opposite side of the outdoor printed circuit board (PCB).

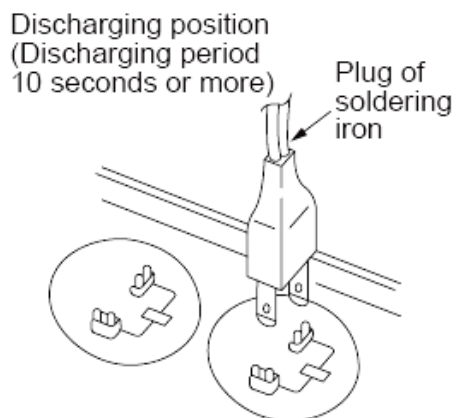

Note: The picture above is for reference purposes only. The design of the devices depicted may vary by model.

16.1 Indoor Unit Error Display

Operation lamp	Timer lamp	Display	LED STATUS
☆ 1 time	X	E0	Indoor unit EEPROM parameter error
☆ 2 times	X	E1	Communication malfunction between indoor and outdoor units
☆ 4 times	X	E3	Indoor fan speed malfunction
☆ 5 times	X	E4	Indoor room temperature sensor (T1) malfunction
☆ 6 times	X	E5	Evaporator coil temperature sensor (T2) malfunction
☆ 7 times	X	EC	Refrigerant leakage detection
☆ 8 times	X	EE	Water-level alarm malfunction
☆ 1 time	O	F0	Current overload protection
☆ 2 times	O	F1	Outdoor ambient temperature sensor (T4) malfunction
☆ 3 times	O	F2	Condenser coil temperature sensor (T3) malfunction
☆ 4 times	O	F3	Compressor discharge temperature sensor (T5) malfunction
☆ 5 times	O	F4	Outdoor unit EEPROM parameter error
☆ 6 times	O	F5	Outdoor fan speed malfunction
☆ 8 times	O	F7	Communication malfunction between indoor unit and auto-lifting panel
☆ 9 times	O	F8	Auto-lifting panel malfunction
☆ 10 times	O	F9	Auto-lifting panel malfunction is not closed
☆ 1 times	☆	P0	Inverter module (IPM) malfunction
☆ 2 times	☆	P1	Over-voltage or under-voltage protection
☆ 3 times	☆	P2	Compressor top high temperature protection (OLP)/ High temperature protection of IPM board
☆ 4 times	☆	P3	Low ambient temperature cut off in heating
☆ 5 times	☆	P4	Compressor drive malfunction
☆ 6 times	☆	P5	Indoor units mode conflict
☆ 7 times	☆	P6	Low pressure protection
☆ 8 times	☆	P7	Outdoor IPM temperature sensor error

O (light) X (off) ☆ (flash)

16.2 Error Display on Two Way Communication Wired Controller

Display	LED STATUS
F0	Communication error between wired controller and indoor unit
F1	The cassette faceplate is abnormal
E7	Indoor unit EEPROM parameter error
E1	Communication malfunction between indoor and outdoor units
E8	Indoor fan speed malfunction
E2	Indoor room temperature sensor (T1) malfunction
E3	Evaporator coil temperature sensor (T2) malfunction
EF	Refrigerant leakage detection
EE	Water-level alarm malfunction
E5	Outdoor ambient temperature sensor (T4) malfunction
E5	Condenser coil temperature sensor (T3) malfunction
E5	Compressor discharge temperature sensor (T5) malfunction
ED	Outdoor unit EEPROM parameter error
ED	Outdoor fan speed malfunction
EB	Inverter module (IPM) malfunction
EF	Other malfunction

16.3 Outdoor unit error display

For 9K-24K outdoor unit:

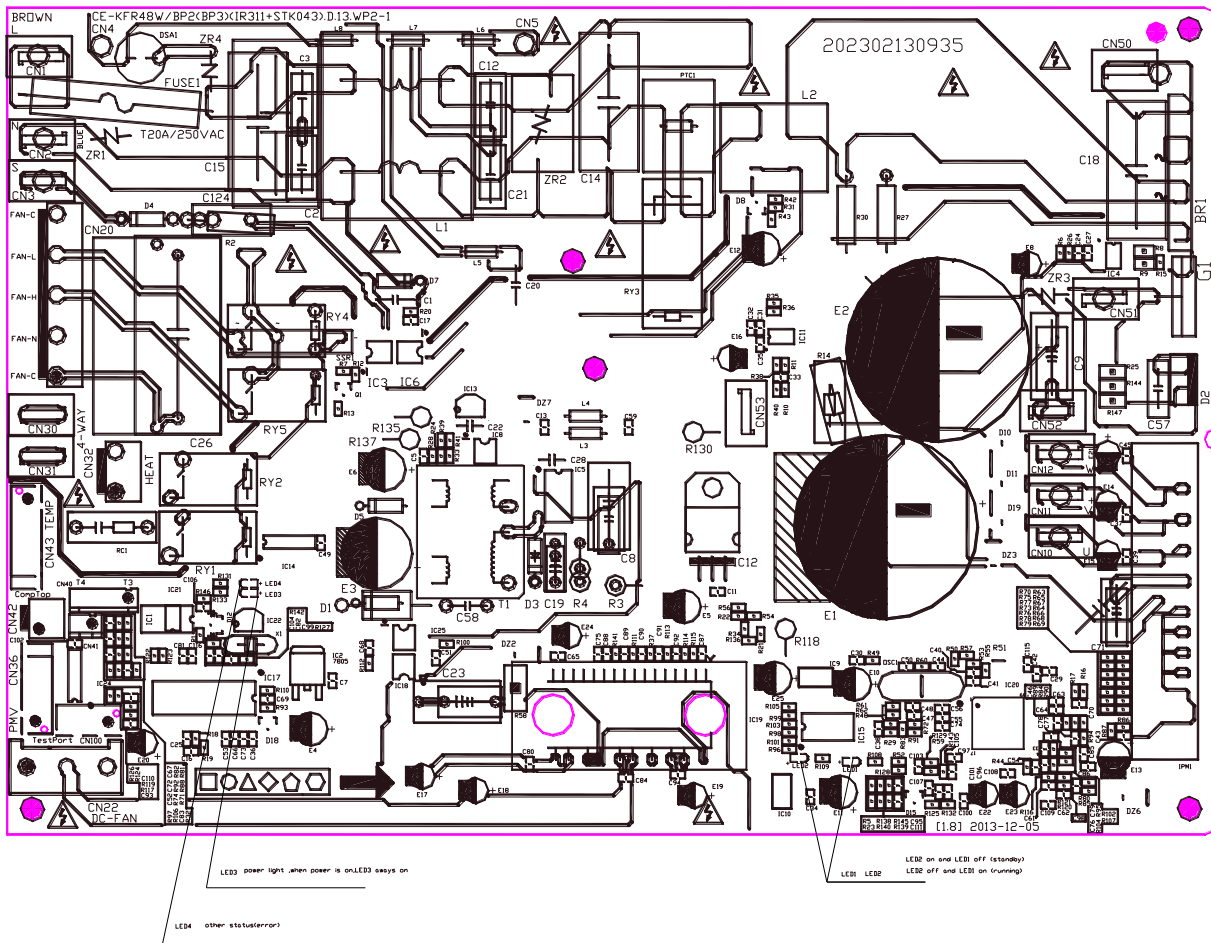

No.	Problems	LED2 (Green)	LED1 (Red)	IU display
1	standby for normal	O	X	
2	Operation normally	X	O	
3	Compressor drive board EEPROM error	O	☆	E5
4	IPM malfunction or IGBT over-strong current protection	☆	X	P0
5	Over voltage or too low voltage protection	O	O	P1
6	Inverter compressor drive error	X	☆	P4
7	Inverter compressor drive error	☆	O	P4
8	Communication malfunction between main control board and driver board	☆	☆	P4

For 36K-60K Outdoor Unit

No	Problems	Error Code
1	Communication malfunction between indoor and outdoor units	E1
2	Current overload protection	F0
3	Outdoor ambient temperature sensor (T4) malfunction	F1
4	Condenser coil temperature sensor (T3) malfunction	F2
5	Compressor discharge temperature sensor (T5) malfunction	F3
6	Outdoor unit EEPROM parameter error	F4
7	Outdoor fan speed malfunction	F5
8	Inverter module (IPM) malfunction	P0
9	Over-voltage or under-voltage protection	P1
10	Compressor top high temperature protection (OLP)	P2
11	Low ambient temperature cut off in heating	P3
12	Compressor drive malfunction	P4
13	High temperature protection of indoor coil in heating	J0
14	Outdoor temperature protection of outdoor coil in cooling	J1
15	Temperature protection of compressor discharge	J2
16	PFC module protection	J3
17	Communication malfunction between control board and IPM board	J4
18	High pressure protection	J5
19	Low pressure protection	J6
20	Outdoor IPM module temperature sensor malfunction	P7
21	AC voltage protection	J8

Outdoor check function

N	Display	Remark
00	Normal display	Display running frequency, running state or malfunction code
01	Indoor unit capacity demand code	Actual data*HP*10 If capacity demand code is higher than 99, the digital display tube will show single digit and tens digit. (For example, the digital display tube show "5.0",it means the capacity demand is 15. the digital display tube show "60",it means the capacity demand is 6.0)
02	Amendatory capacity demand code	
03	The frequency after the capacity requirement transfer	
04	The frequency after the frequency limit	
05	The frequency of sending to 341 chip	
06	Indoor unit evaporator temperature	If the temp. is lower than 0 degree, the digital display tube will show "0".If the temp. is higher than 70 degree, the digital display tube will show "70".
07	Condenser pipe temp.(T3)	If the temp. is lower than -9 degree, the digital display tube

08	Outdoor ambient temp.(T4)	will show “-9”.If the temp. is higher than 70 degree, the digital display tube will show “70”. If the indoor unit is not connected, the digital display tube will show: “——”		
09	Compressor discharge temp.(T5)	The display value is between 13~129 degree. If the temp. is lower than 13 degree, the digital display tube will show “13”.If the temp. is higher than 99 degree, the digital display tube will show single digit and tens digit. (For example, the digital display tube show “0.5”,it means the compressor discharge temp. is 105 degree. the digital display tube show “1.6”,it means the compressor discharge temp. is 116 degree)		
10	AD value of current	The display value is hex number.		
11	AD value of voltage			
12	Indoor unit running mode code	Off:0, Fan only 1,Cooling:2, Heating:3		
13	Outdoor unit running mode code	Off:0, Fan only 1,Cooling:2, Heating:3, Forced cooling:4		
14	EXV open angle	Actual data/4. If the value is higher than 99, the digital display tube will show single digit and tens digit. For example, the digital display tube show “2.0”,it means the EXV open angle is 120×4=480p.)		
15	Frequency limit symbol	Bit7	Frequency limit caused by IGBT radiator	The display value is hex number. For example, the digital display tube show 2A, then Bit5=1, Bit3=1, Bit1=1. It means frequency limit caused by T4, T3 and current.
		Bit6	Frequency limit caused by PFC	
		Bit5	Frequency limit caused by T4.	
		Bit4	Frequency limit caused by T2.	
		Bit3	Frequency limit caused by T3.	
		Bit2	Frequency limit caused by T5.	
		Bit1	Frequency limit caused by current	
Bit0	Frequency limit caused by voltage			
16	DC fan motor speed			
17	IGBT radiator temp.	The display value is between 30~120 degree. If the temp. is lower than 30 degree, the digital display tube will show “30”.If the temp. is higher than 99 degree, the digital display tube will show single digit and tens digit. (For example, the digital display tube show “0.5”,it means the IGBT radiator temp. is 105 degree. the digital display tube show “1.6”,it means the IGBT radiator temp. is 116 degree)		
18	Indoor unit number	The indoor unit can communicate with outdoor unit well. General:1, Twins:2		
19	Evaporator pipe temp. T2 of 1# indoor unit	If the temp. is lower than 0 degree, the digital display tube will show “0”.If the temp. is higher than 70 degree, the digital display tube will show “70”. If the indoor unit is not		
20	Evaporator pipe temp. T2 of 2# indoor unit			
21	Evaporator pipe temp. T2 of 3# indoor unit			

		connected, the digital display tube will show: “——”
22	1# Indoor unit capacity demand code	Actual data*HP*10 If capacity demand code is higher than 99, the digital display tube will show single digit and tens digit. (For example, the digital display tube show “5.0”,it means the capacity demand is 15. the digital display tube show “60”,it means the capacity demand is 6.0). If the indoor unit is not connected, the digital display tube will show: “——”
23	2# Indoor unit capacity demand code	
24	3# Indoor unit capacity demand code	
25	Room temp. T1 of 1# indoor unit	If the temp. is lower than 0 degree, the digital display tube will show “0”.If the temp. is higher than 70 degree, the digital display tube will show “70”. If the indoor unit is not connected, the digital display tube will show: “——”
26	Room temp. T1 of 2# indoor unit	
27	Average room temp. T1	
28	Reason of stop	
29	Evaporator pipe temp. T2B of 1# indoor unit	If the temp. is lower than 0 degree, the digital display tube will show “0”.If the temp. is higher than 70 degree, the digital display tube will show “70”. If the indoor unit is not connected, the digital display tube will show: “——”
30	Evaporator pipe temp. T2B of 2# indoor unit	

16.4 Diagnosis and Solution

16.4.1 EEPROM parameter error diagnosis and solution (E0/F4)

Error Code	E0/F4
Malfunction conditions	Indoor or outdoor PCB main chip does not receive feedback from EEPROM chip.
Potential causes	<ul style="list-style-type: none">● Installation mistake● Faulty PCB

Trouble shooting:

Power off, then restart the unit 2 minutes later. Does a problem still remain?

Yes

Replace the indoor/outdoor main PCB.

EEPROM: a type of read-only memory. The contents can be erased and reprogrammed using a pulsed voltage. To locate the EEPROM chip,

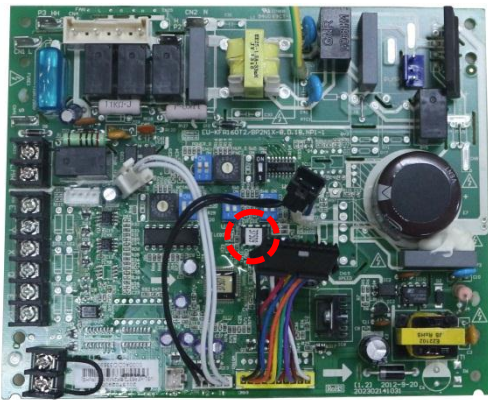

Indoor PCB



Outdoor PCB

Note: The two photos above are only for reference purposes only. The design of the devices depicted may vary by model.

16.4.2 Communication malfunction between indoor and outdoor units diagnosis and solution (E1)

For 9K-24K:

Error Code	E1
Malfunction conditions	If the indoor unit does not receive feedback from outdoor unit for 110 seconds 4 consecutive times.
Potential causes	<ul style="list-style-type: none"> ● Wiring mistake ● Faulty indoor or outdoor PCB

Trouble shooting:

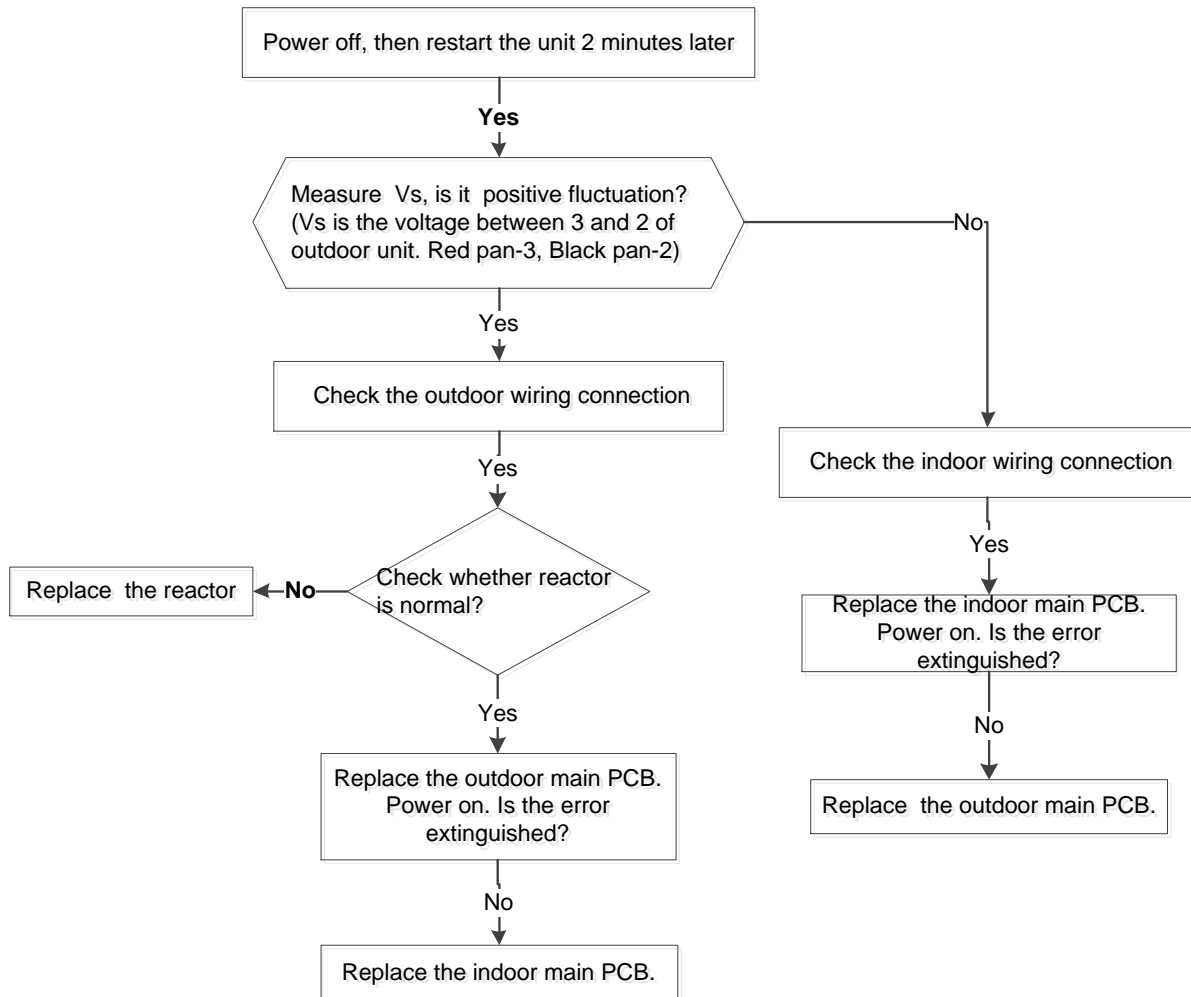

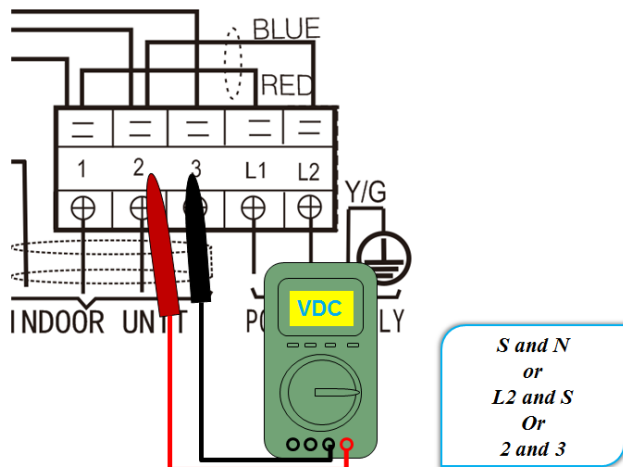

Remark:

Use a multimeter to test the DC voltage between 2 port and 3 port of outdoor unit. The red pin of multimeter connects with 2 port while the black pin is for 3 port.

When AC is normal running, the voltage will move alternately between -50V to 50V.

If the outdoor unit has malfunction, the voltage will move alternately with positive value.

While if the indoor unit has malfunction, the voltage will be a certain value.

Remark,

The old label is L1,L2,S, L1,L2

The new label is 1, 2, 3, L1,L2

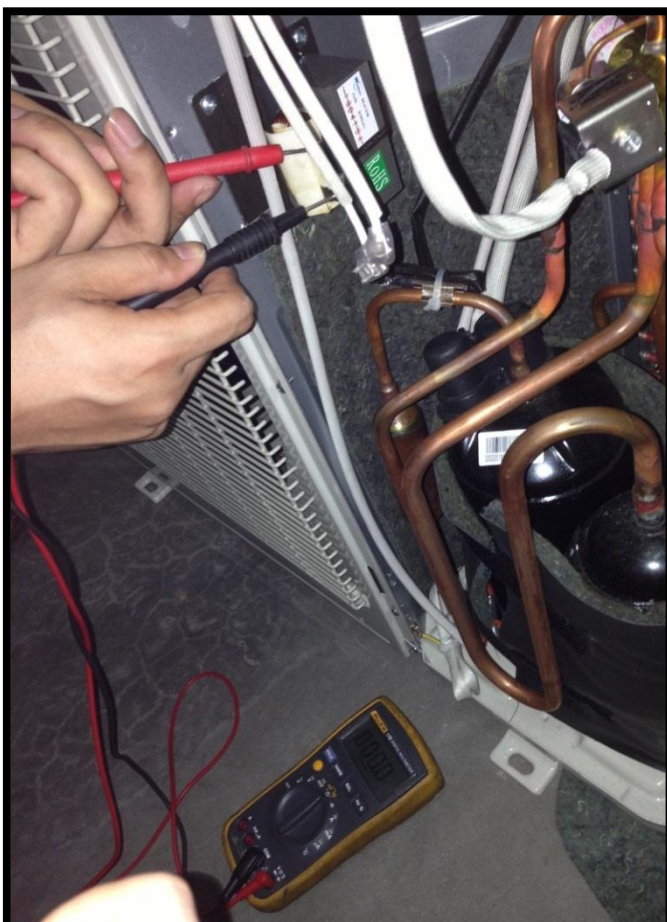

Remark:

Use a multimeter to test the resistance of the reactor which does not connect with capacitor.

The normal value should be around zero ohm. Otherwise, the reactor must have malfunction and need to be replaced.

For 36K-48K:

Malfunction conditions	Indoor unit does not receive feedback from outdoor unit for 60 seconds OR outdoor unit does not receive feedback from indoor unit for 120 seconds.
Possible causes	<ul style="list-style-type: none"> ● Wiring mistakes ● Faulty indoor or outdoor PCB

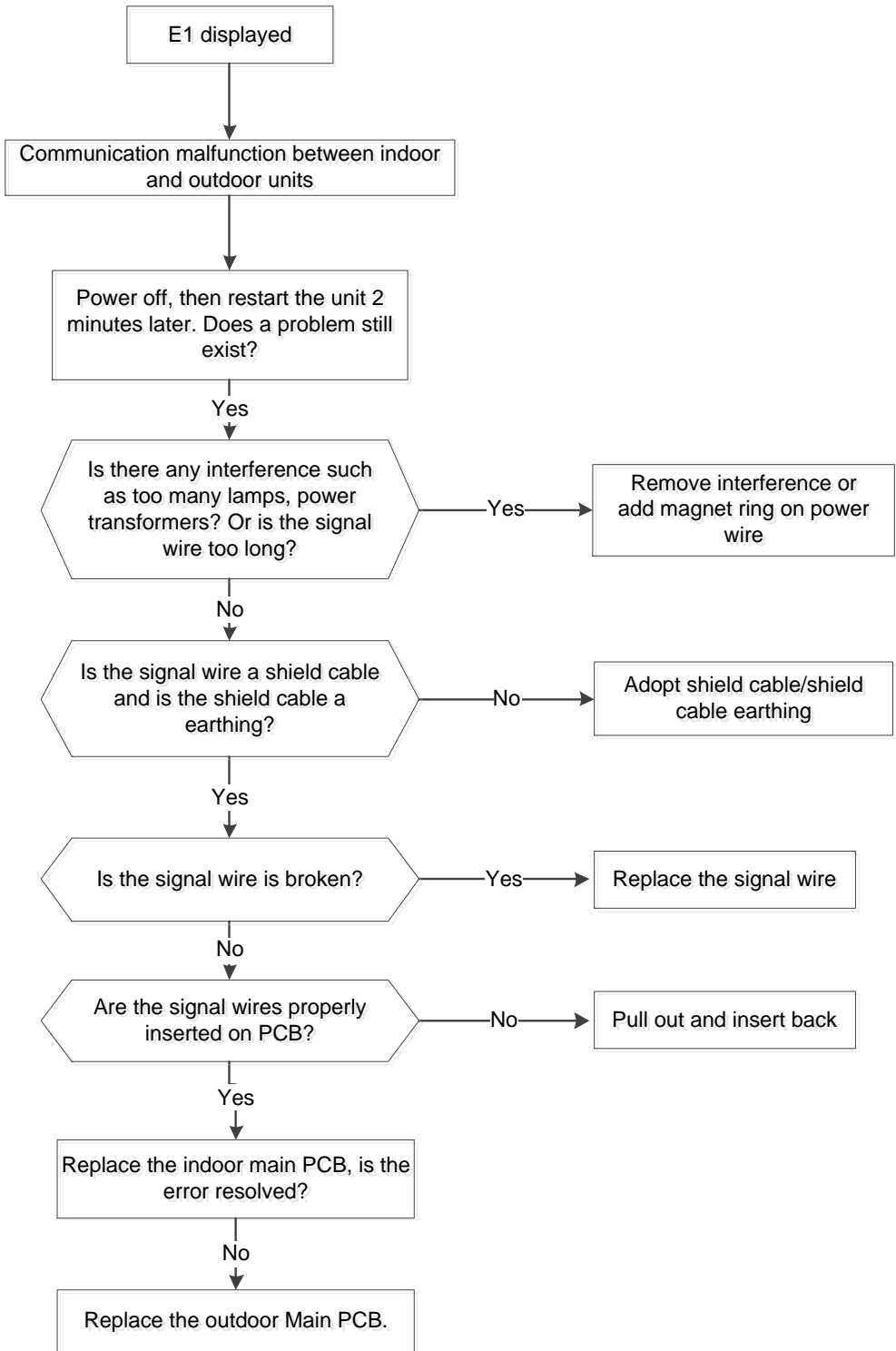

16.4.3 Fan speed malfunction diagnosis and solution (E3/F5)

Error Code	E3/F5
Malfunction conditions	When indoor fan speed is too low (300RPM) for a certain period of time, the unit ceases operation and the LED displays a failure code.
Potential Causes	<ul style="list-style-type: none"> ● Wiring mistake ● Faulty fan assembly ● Faulty fan motor ● Faulty PCB

Trouble shooting:

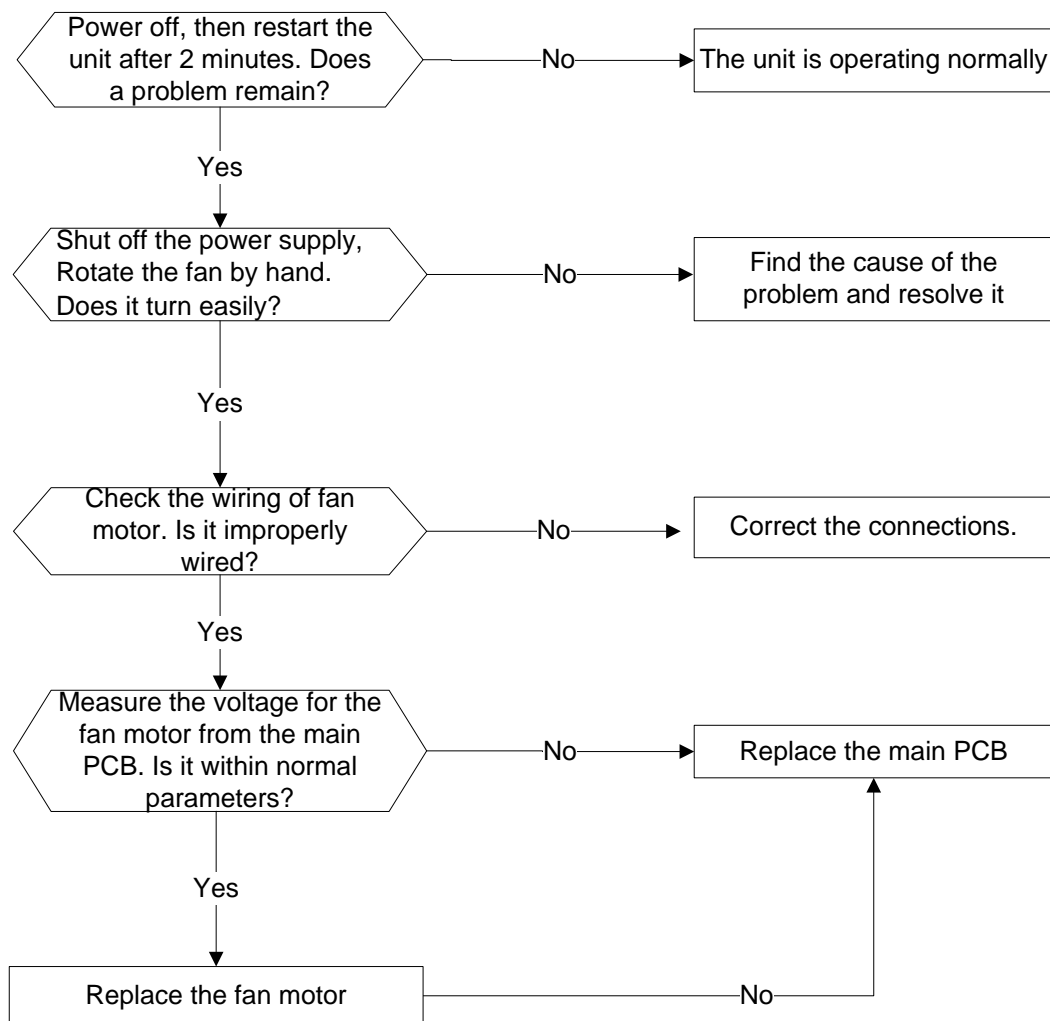

Index 1:

1. Indoor or outdoor DC fan motor (Control Chip is in Fan Motor)

Turn power on and while the unit is on standby, measure the voltage between pin1 and pin3 as well as between pin4 and pin3 in fan motor connector. If the value of the voltage is not within the range shown in the following table, the PCB may be experiencing problems and need to be replaced.

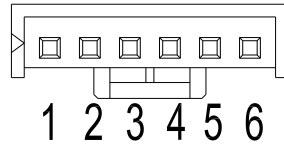

DC motor voltage input and output

NO.	Color	Signal	Voltage
1	Red	Vs/Vm	200~380V
2	---	---	---
3	Black	GND	0V
4	White	Vcc	13.5~16.5V
5	Yellow	Vsp	0~6.5V
6	Blue	FG	13.5~16.5V

2. Indoor or outdoor DC Fan Motor (control chip is in PCB)

Release the UVW connector. Measure the resistance of U-V, U-W, and V-W. If the resistances are not equal to each other, the fan motor may be experiencing problems and need to be replaced. Otherwise, the PCB must has problems and need to be replaced.

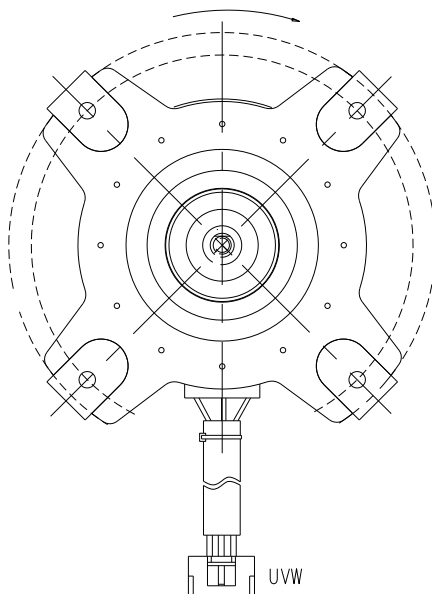

16.4.4 Open or short circuit of temperature sensor diagnosis and solution (E4/E5/F1/F2/F3)

Error Code	E4/E5/F1/F2/F3
Malfunction conditions	If the sampling voltage is lower than 0.06V or higher than 4.94V, the LED displays a failure.
Potential causes	<ul style="list-style-type: none"> ● Wiring mistake ● Faulty sensor

Trouble shooting:

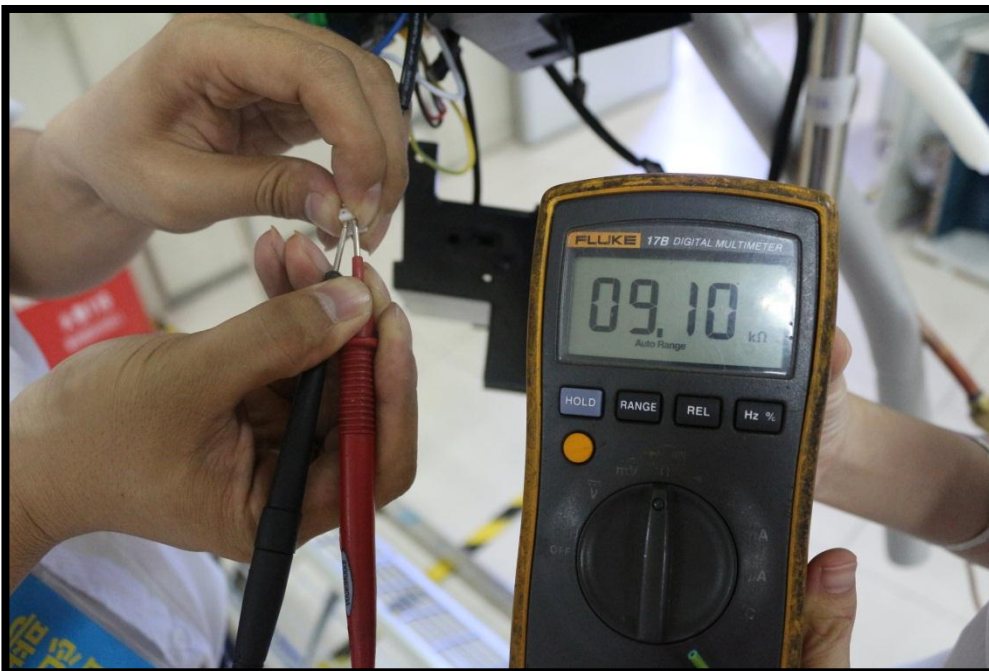
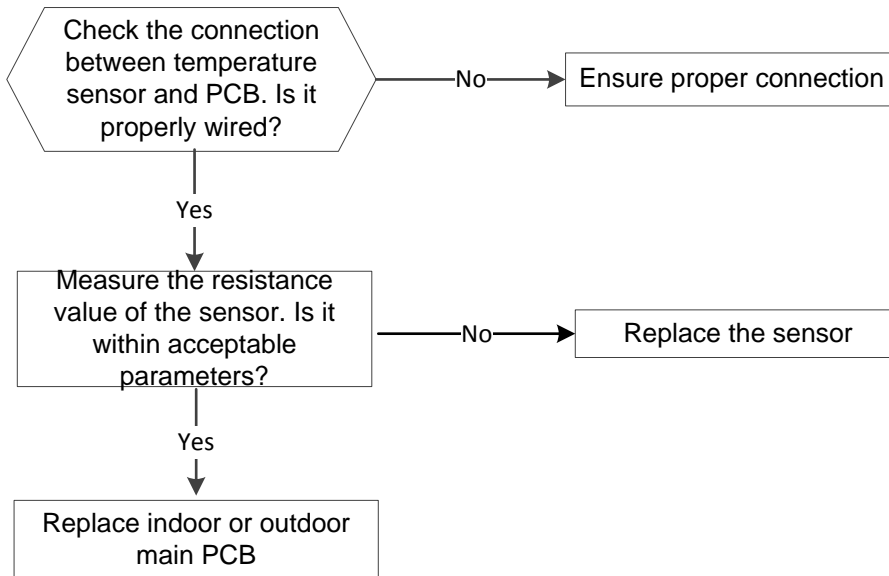

16.4.5 Refrigerant Leakage Detection diagnosis and solution (EC)

Error Code	EC
Malfunction conditions	<p>Define the evaporator coil temperature T2 of the compressor starts running as Tcool.</p> <p>If the following occurs 3 times, the display shows "EC" and the unit switches off:</p> <p>In the first 8 minutes after the compressor starts up, if $T2 < T_{cool} - 2^{\circ}\text{C}$ is not maintained for 4 seconds and compressor</p>
Potential Causes	<ul style="list-style-type: none"> ● Faulty T2 sensor ● Faulty indoor PCB ● System problems, such as leakage or blockages

Trouble shooting:

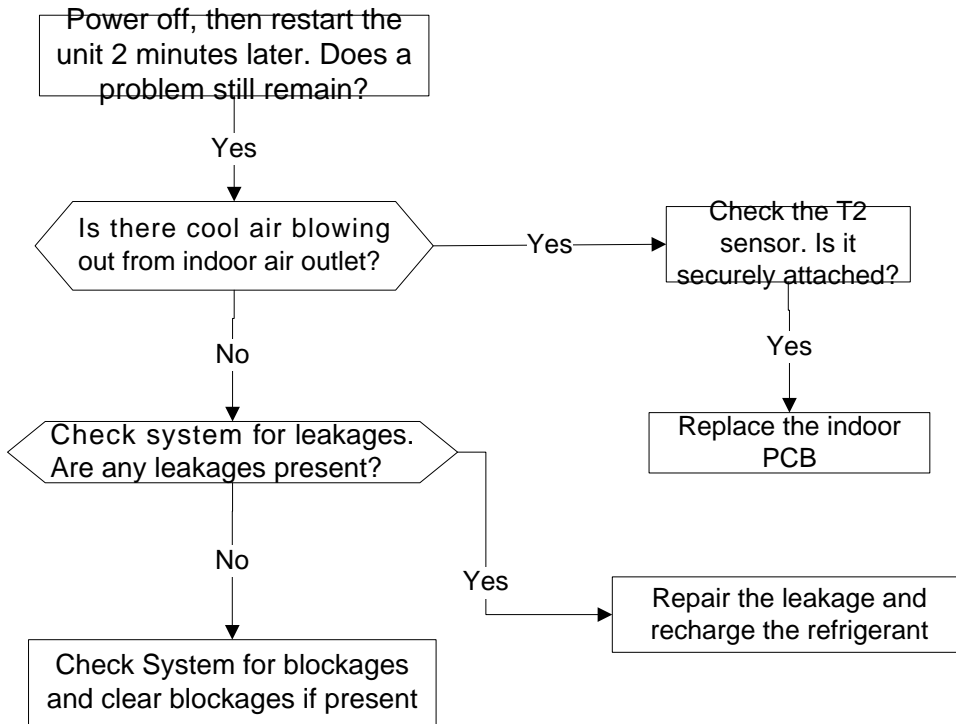

16.4.6 Water-level alarm malfunction diagnosis and solution

Error Code	EE
Malfunction conditions	If the sampling voltage is not 5V, the LED will display the failure code.
Possible causes	<ul style="list-style-type: none"> ● Wiring mistakes ● Faulty water-level switch ● Faulty water pump ● Faulty indoor PCB

Power off, then restart the unit 3 minutes later. Is it still displaying the error code?

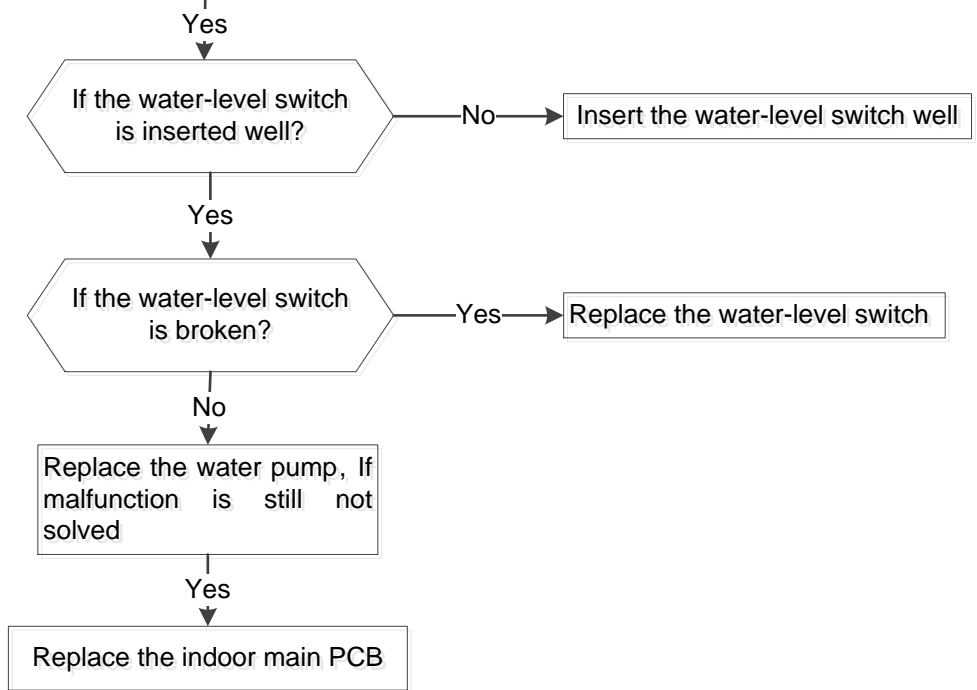

16.4.7 IPM malfunction or IGBT over-strong current protection diagnosis and solution (P0)

Error Code	P0
Malfunction conditions	When the voltage signal the IPM sends to the compressor drive chip is abnormal, the display LED shows “P0” and the AC turn
Possible causes	<ul style="list-style-type: none"> ● Wiring mistake ● IPM malfunction

Trouble shooting:

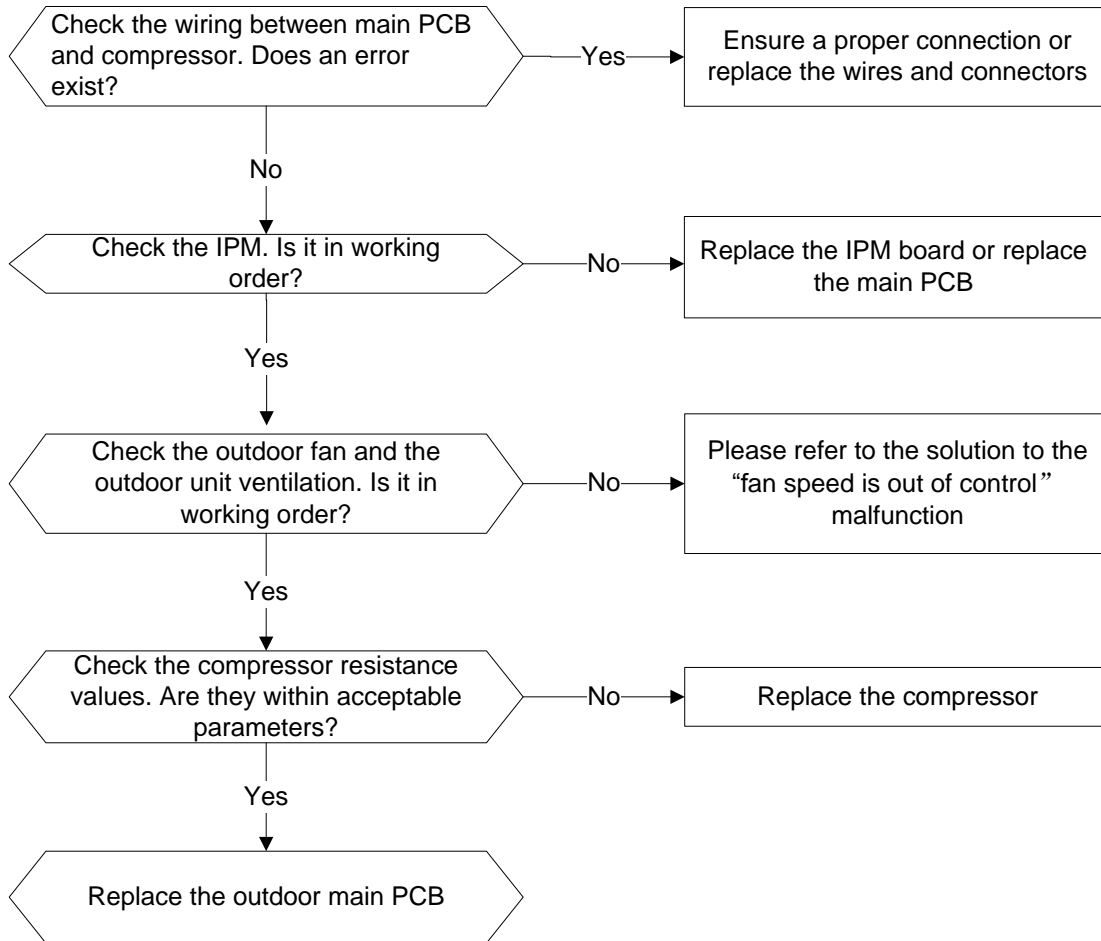

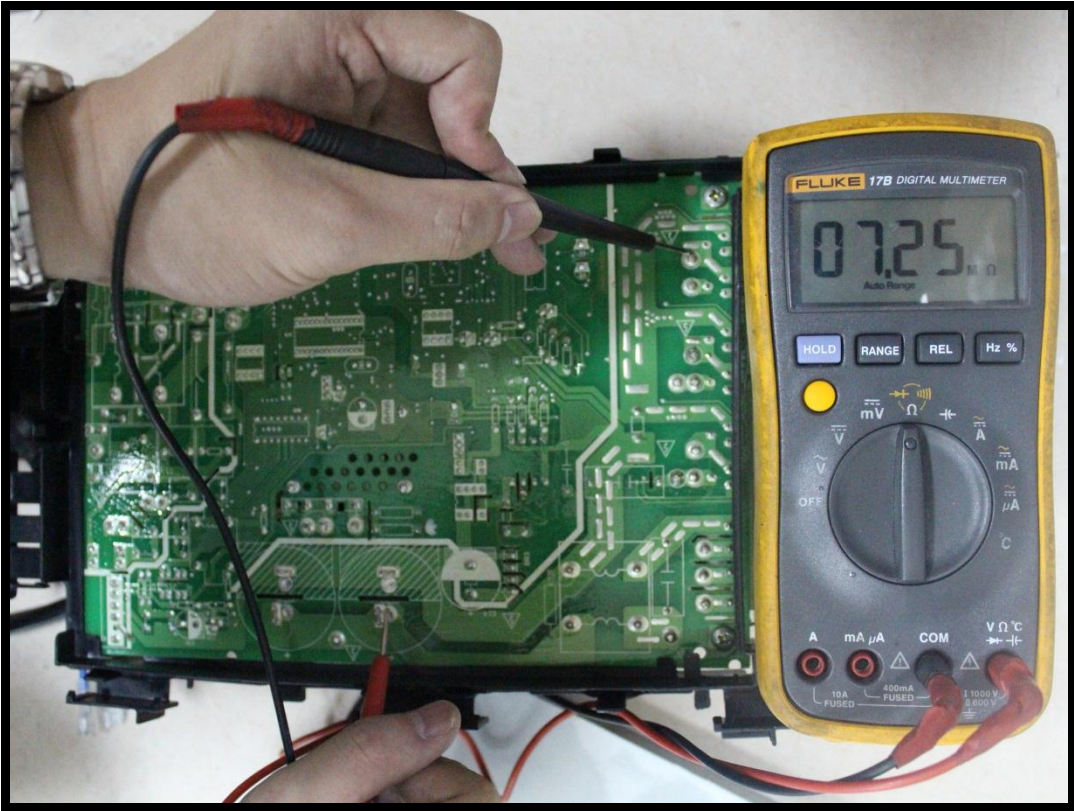

P-U

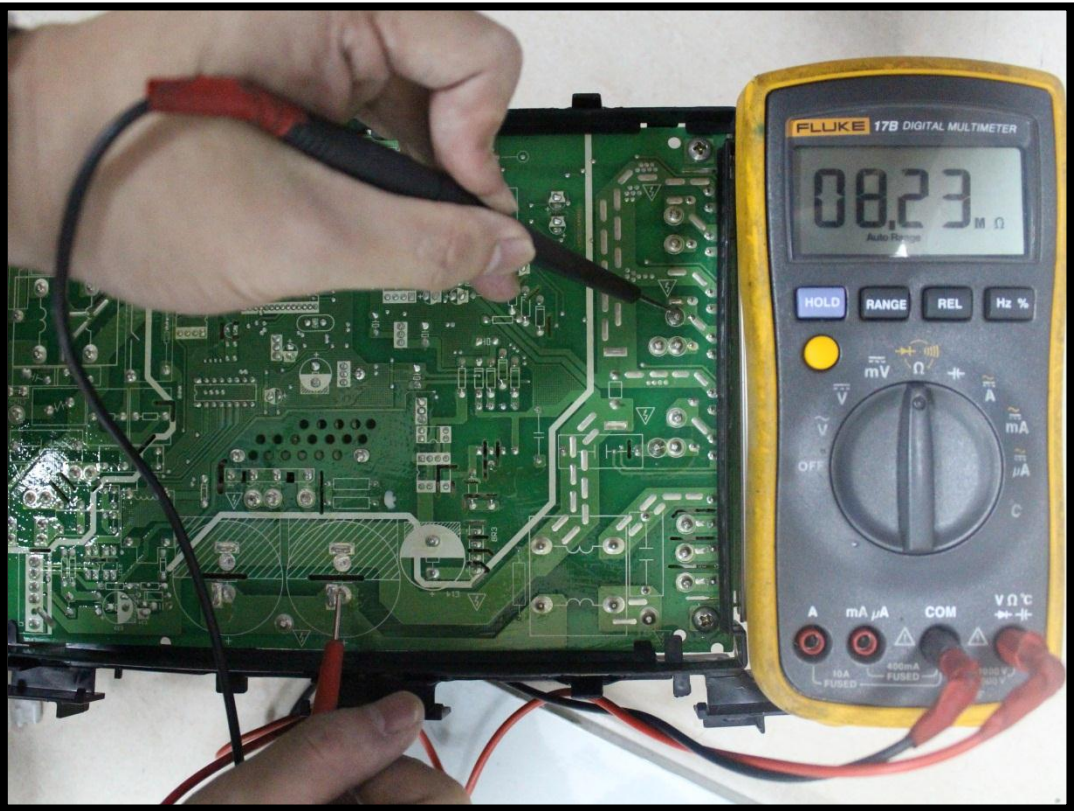

P-V

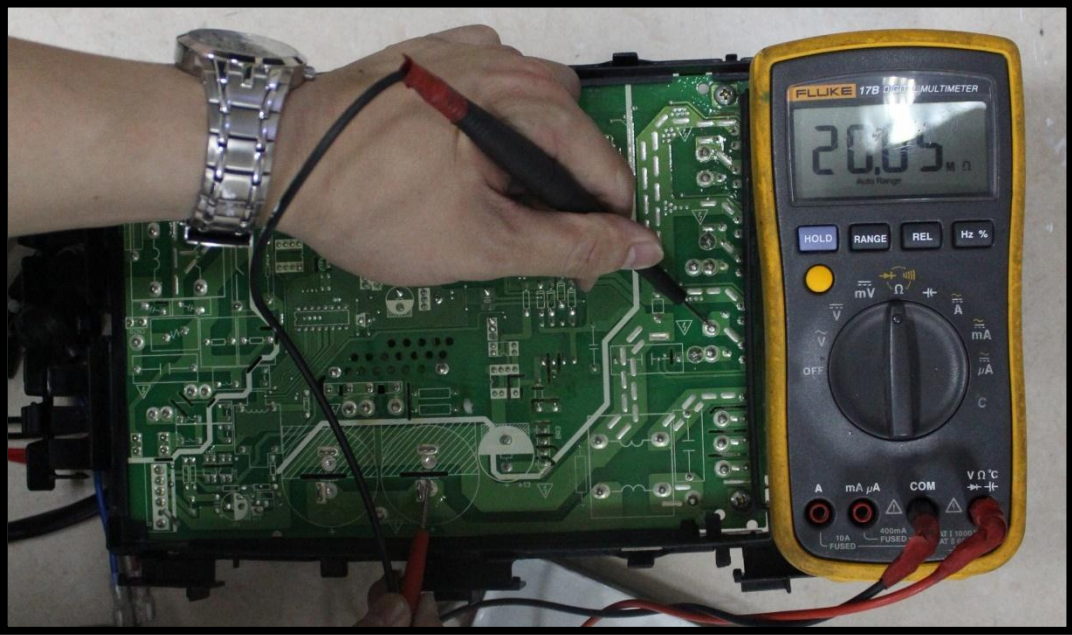

P-W

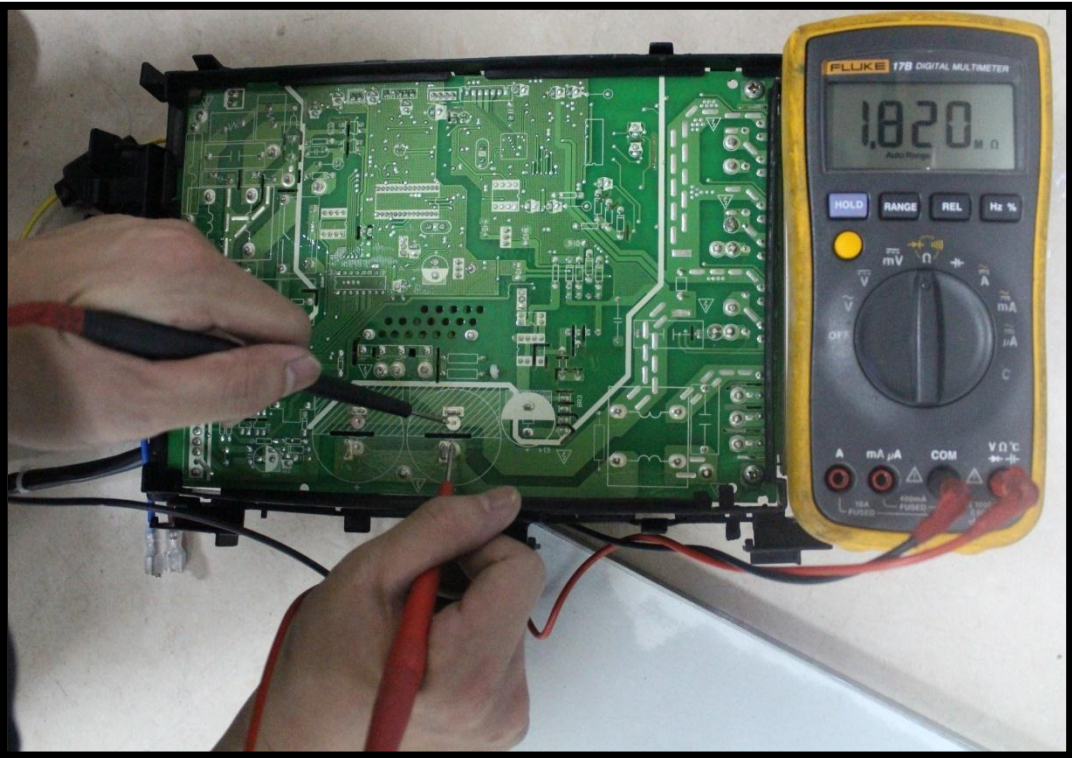

P-N

16.4.8 Over-voltage or under-voltage protection diagnosis and solution (P1)

Error Code	P1
Malfunction conditions	Abnormal increases or decreases in voltage are detected by checking the specified voltage detection circuit.
Potential causes	<ul style="list-style-type: none"> ● Power supply issues ● System leakage or blockage ● Faulty PCB

Trouble shooting:

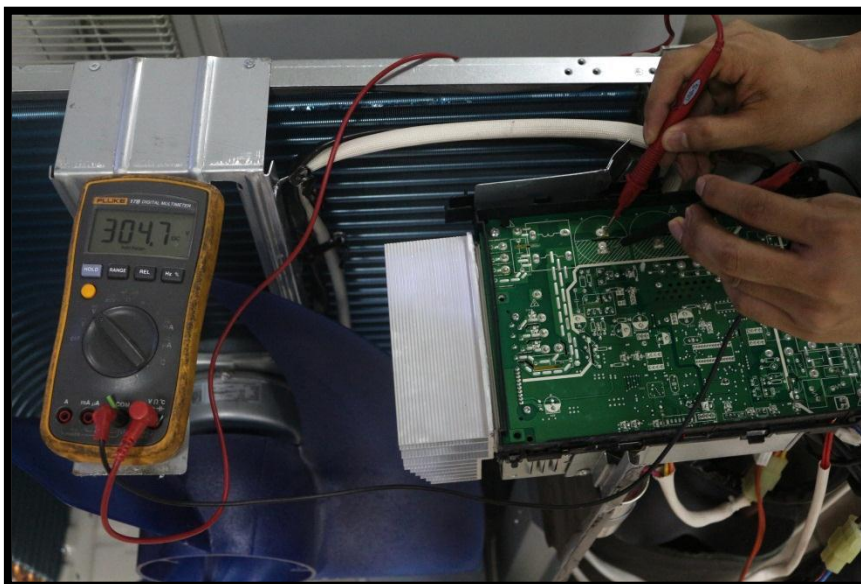
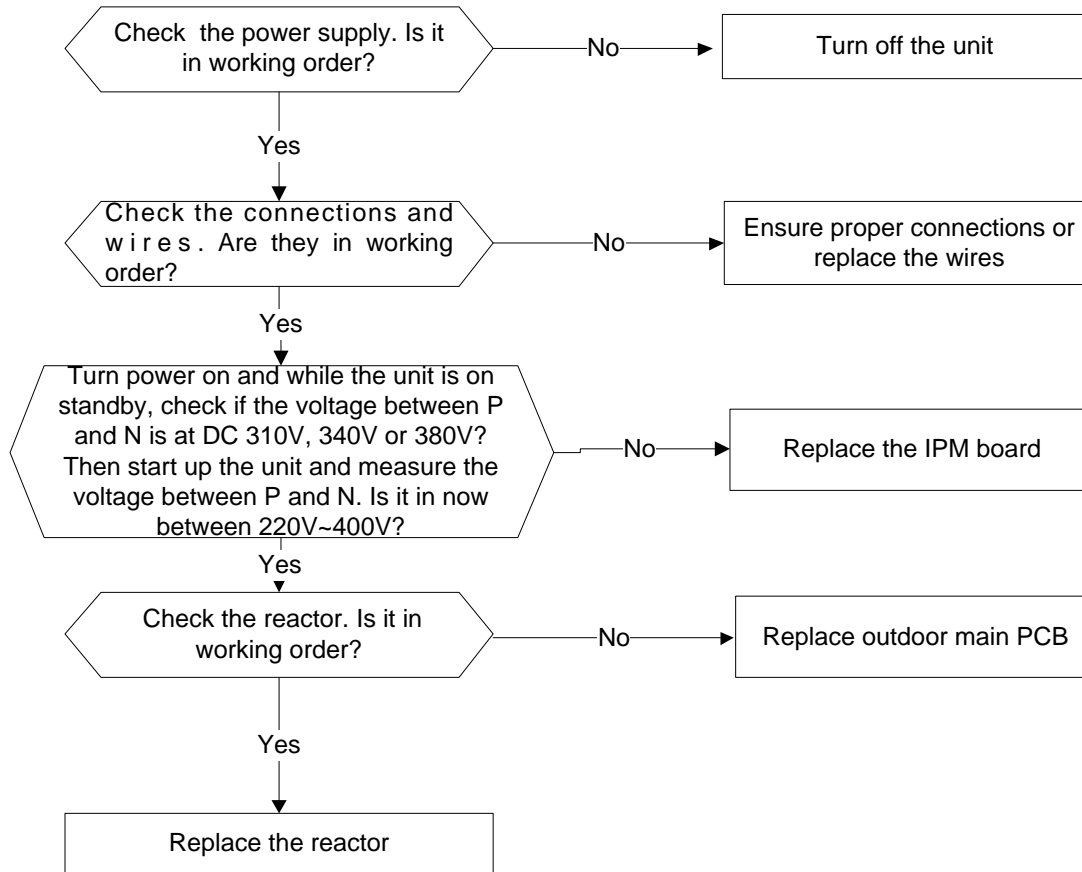

Remark:
 Measure the DC voltage between P and N port.
 The normal value should be around 310V.340V or 380V

16.4.9 High temperature protection of compressor top diagnosis and solution (P2)

Error Code	P2
Malfunction decision conditions	If the sampling voltage is not 5V, the LED will display the failure.
Supposed causes	<ul style="list-style-type: none"> ● Power supply problems. ● System leakage or block ● PCB faulty

Trouble shooting:

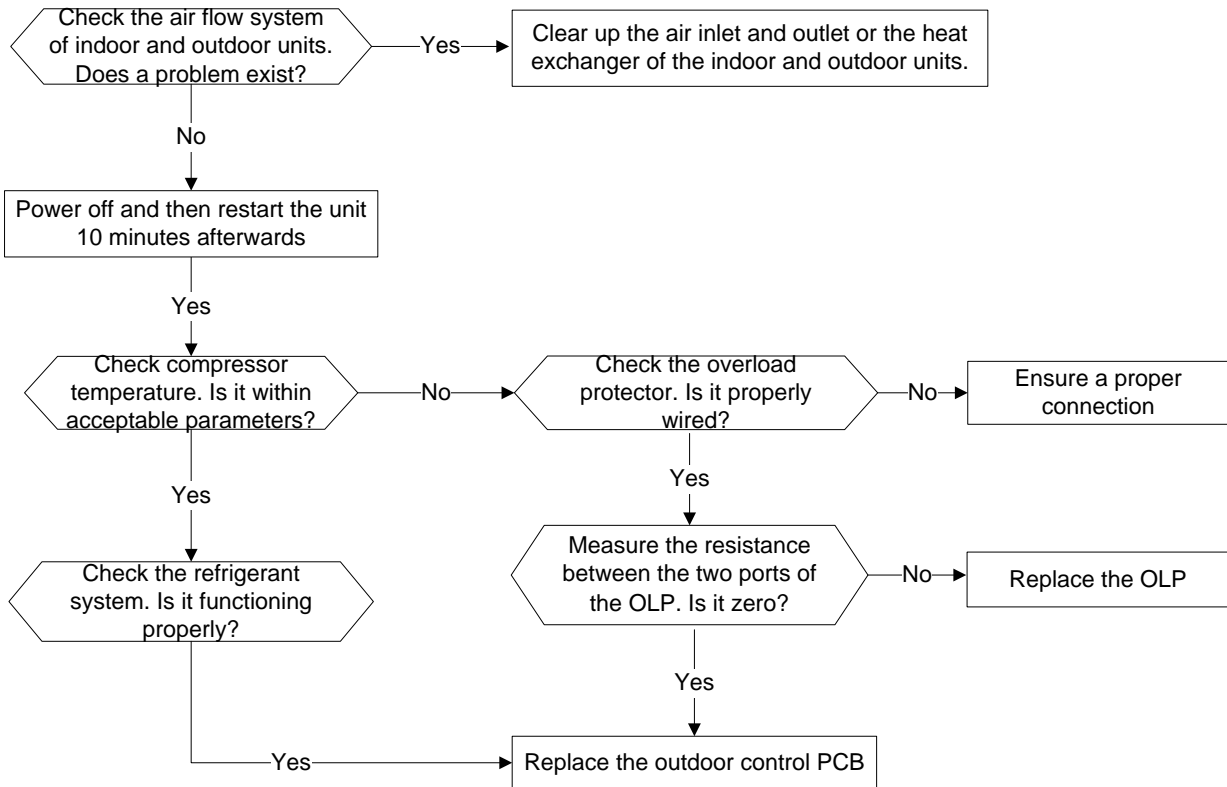

High temperature protection of IPM board diagnosis and solution (P2)

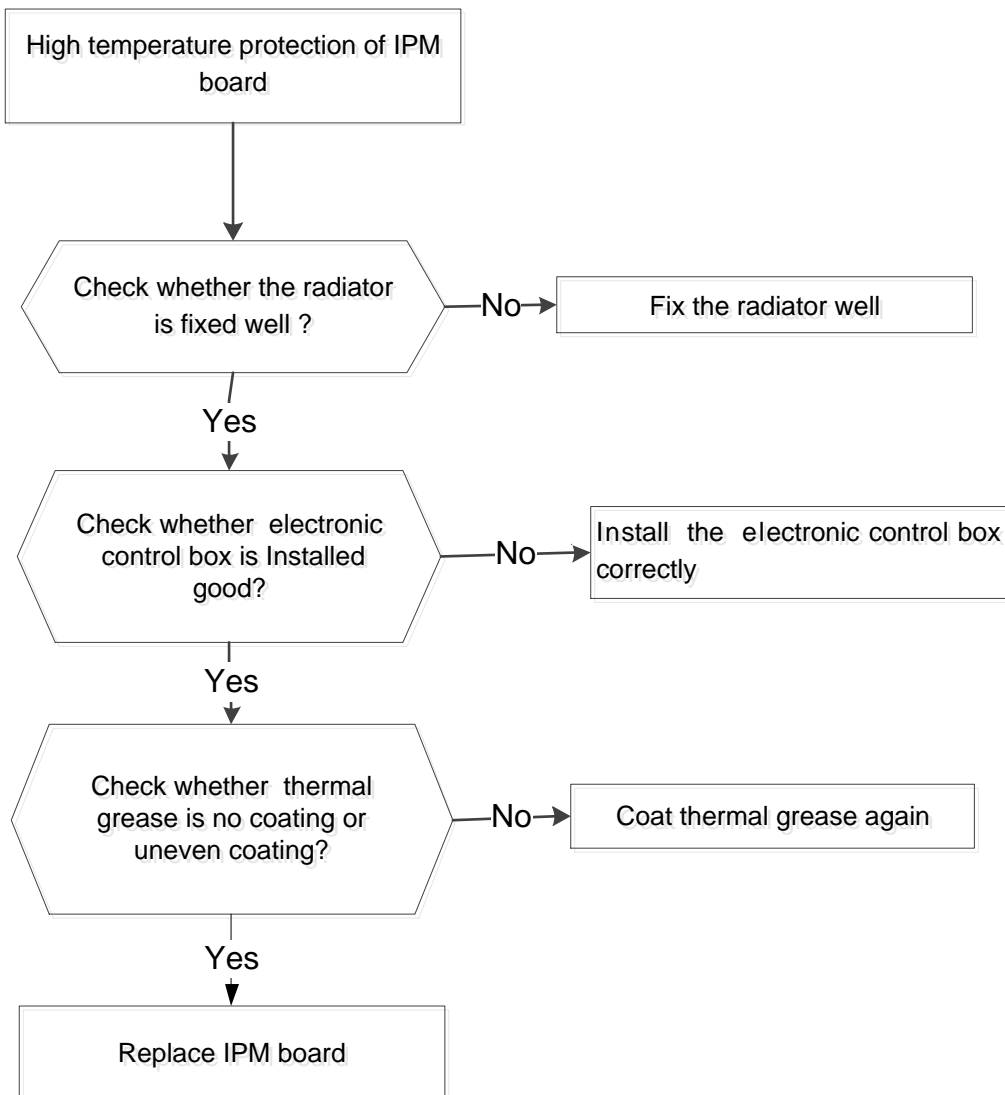

16.4.10 Inverter compressor drive error diagnosis and solution(P4)

Error Code	P4
Malfunction conditions	Abnormalities in the inverter compressor drive is detected by a special detection circuit, which can perform communication signal detection, voltage detection, and compressor rotation speed signal detection.
Potential causes	<ul style="list-style-type: none"> ● Wiring mistake ● IPM malfunction ● Faulty outdoor fan assembly ● Compressor malfunction ● Faulty outdoor PCB

Trouble shooting:

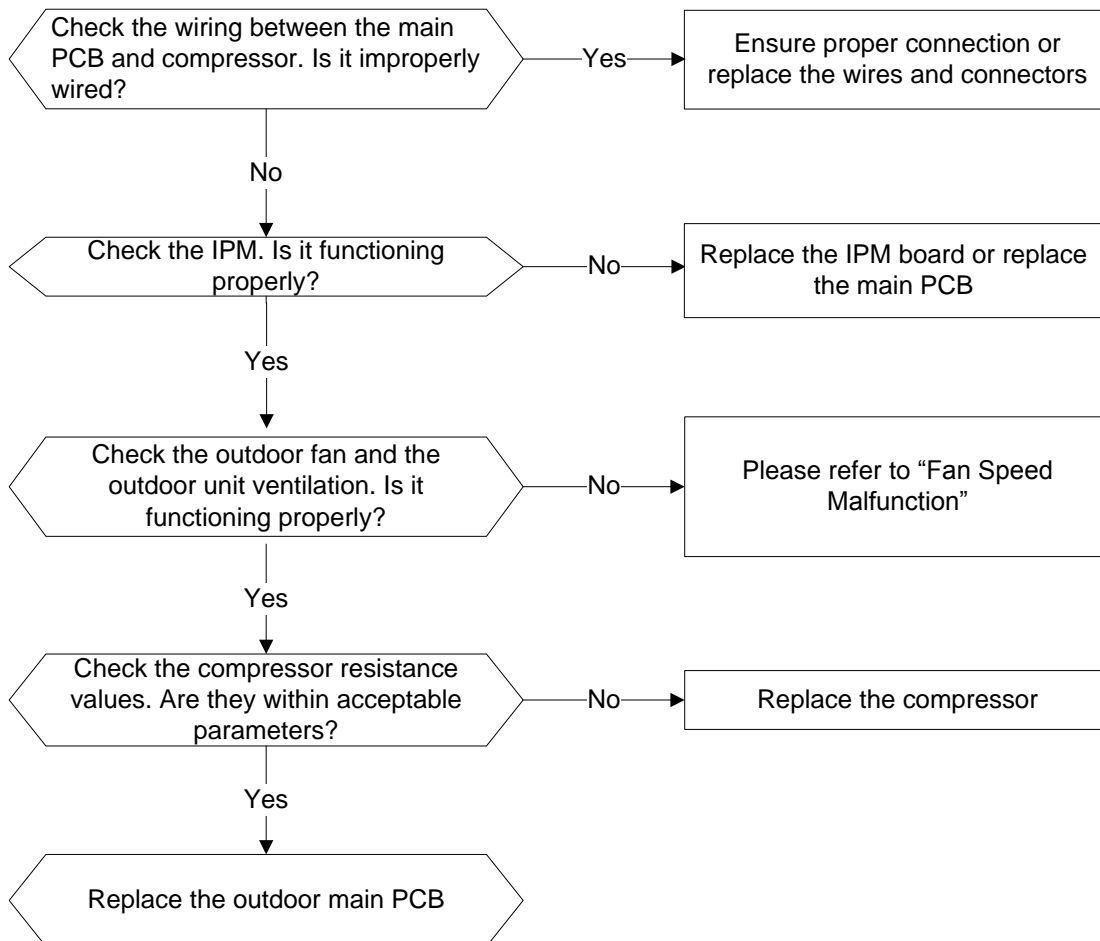

16.4.11 Outdoor IPM module temperature sensor malfunction diagnosis and solution (P7)

Error Code	P7
Malfunction conditions	If the sampling voltage is lower than 0.06V or higher than 4.94V, the LED displays a failure.
Potential causes	<ul style="list-style-type: none">● Wiring mistake● Faulty sensor

Trouble shooting:

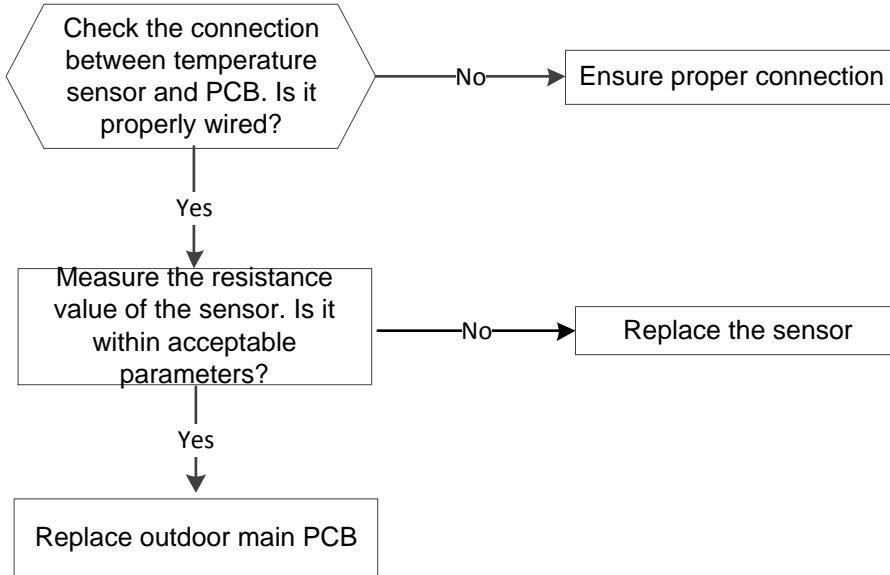

16.4.12. J0 Malfunction

Malfunction conditions	When evaporator coil temperature is more than 60°C, the unit stops. It starts again only when the evaporator coil temperature is less than 54°C
Possible causes	<ul style="list-style-type: none"> • Faulty evaporator coil temperature sensor • Dirty heat exchanger • Faulty fan • Faulty PCB

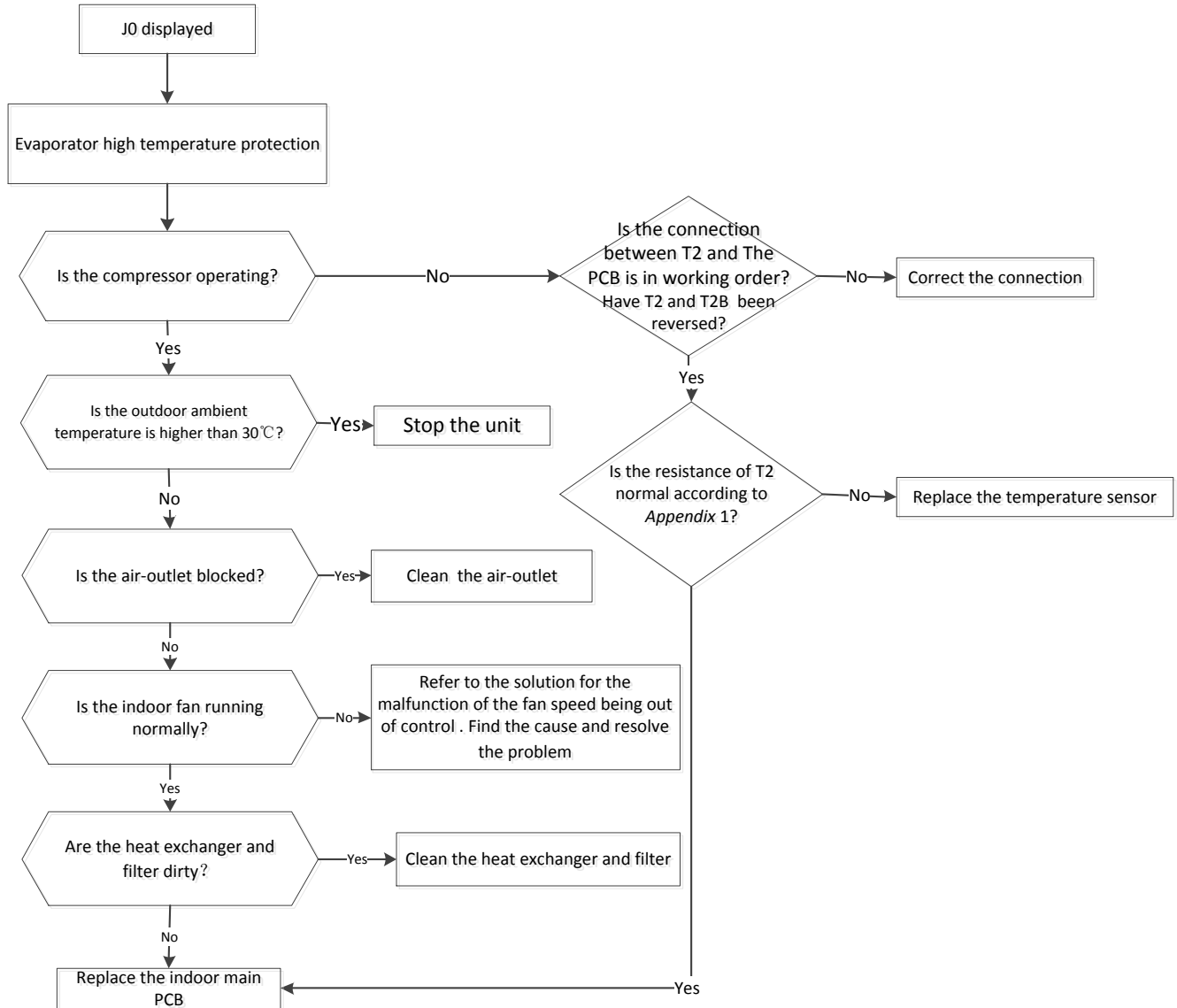

16.4.13. J1 Malfunction

Malfunction conditions	When the outdoor pipe temperature is more than 65°C, the unit stops. It starts again only when the outdoor pipe temperature is less than 52°C.
Possible causes	<ul style="list-style-type: none"> ● Faulty condenser temperature sensor ● Dirty heat exchanger ● System leakage or blockages

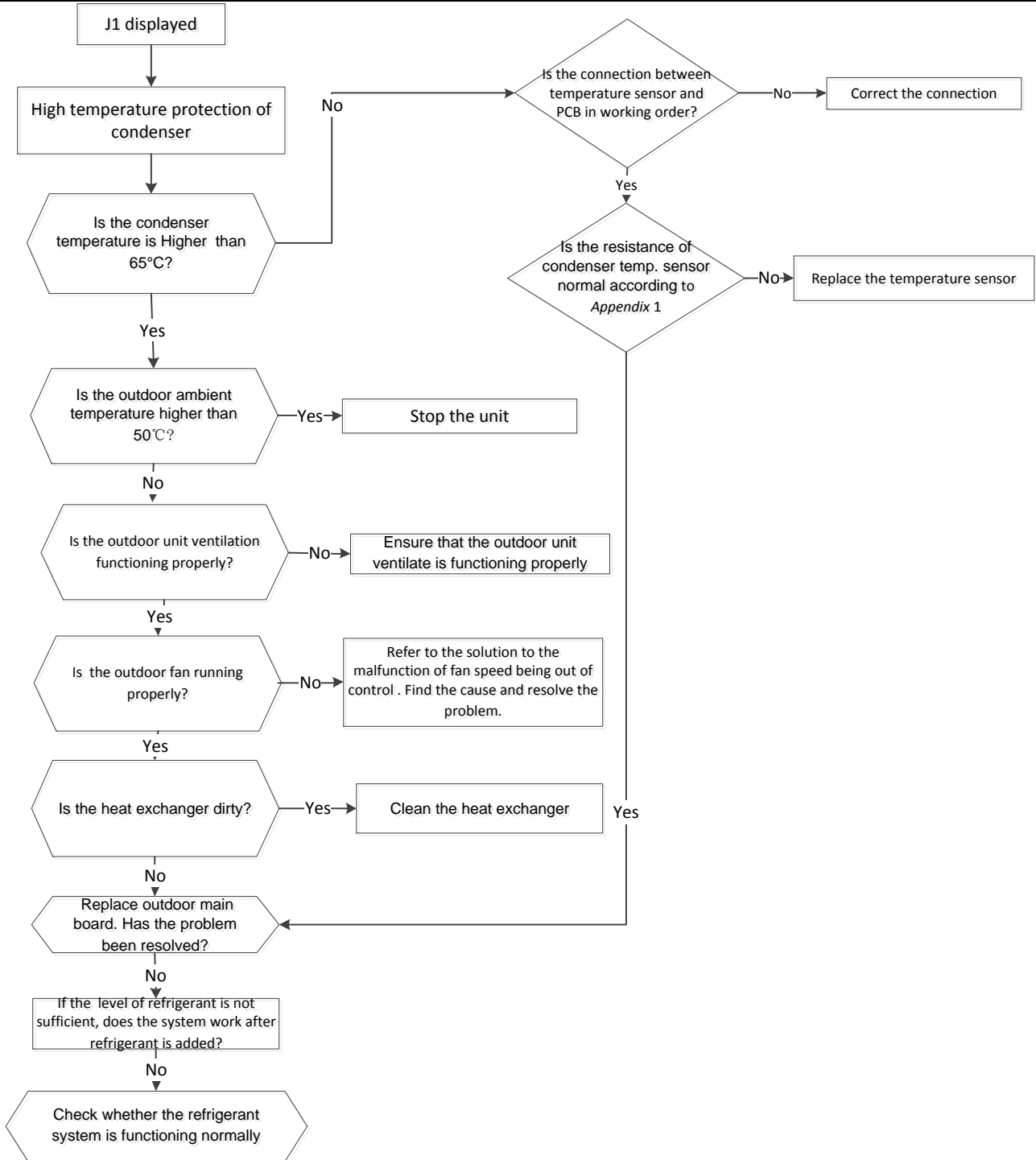

16.4.14. J2 Malfunction

Malfunction conditions	When the compressor discharge temperature (T5) is more than 115°C for 10 seconds, the compressor will stop and not restart until T5 is less than 90°C.
Possible causes	<ul style="list-style-type: none"> ● Refrigerant leakage ● Wiring mistake ● Faulty discharge temperature sensor ● Faulty outdoor PCB

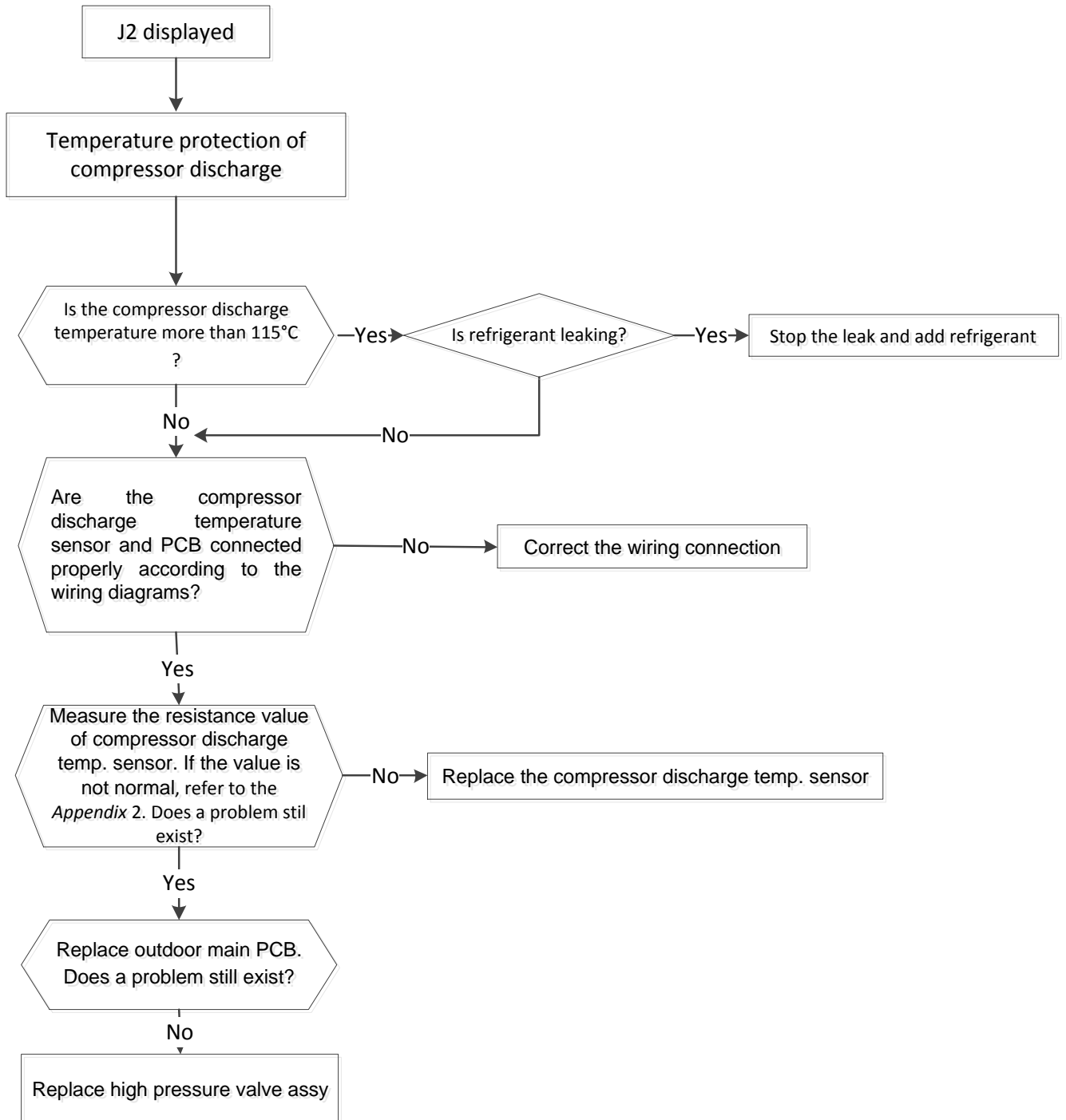

16.4.15. J3 Malfunction

Malfunction decision conditions	When the voltage signal that IPM send to compressor drive chip is abnormal, the display LED will show "J3" and AC will turn off.
Supposed causes	<ul style="list-style-type: none"> ● Wiring mistake ● Faulty IPM board ● Faulty outdoor fan ass'y ● Compressor malfunction ● Faulty outdoor PCB

At first test the resistance between every two ports of U, V, W of IPM and P, N. If any result of them is 0 or close to 0, the IPM is defective. Otherwise, please follow the procedure below:

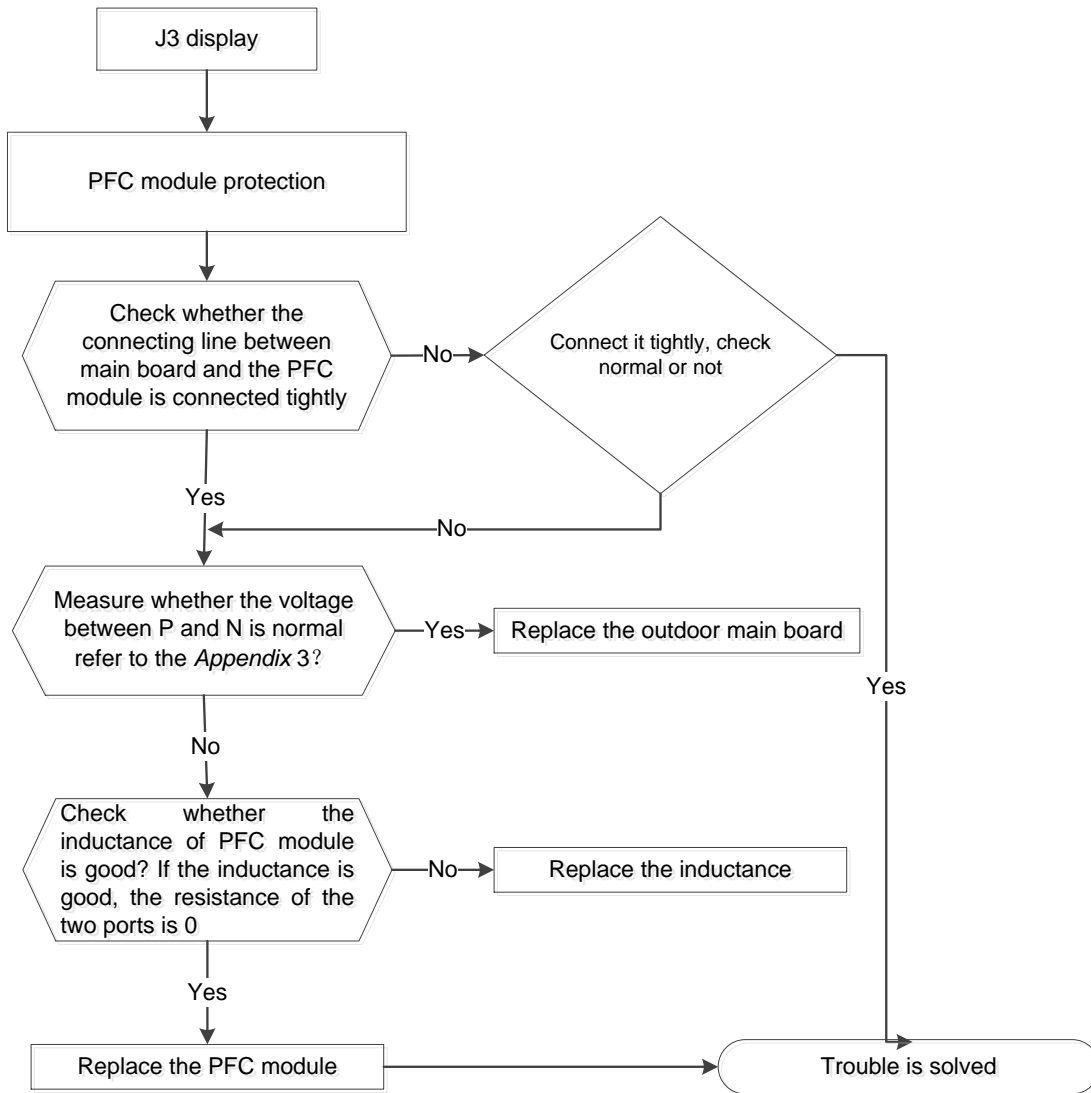

16.4.16. J4 Malfunction

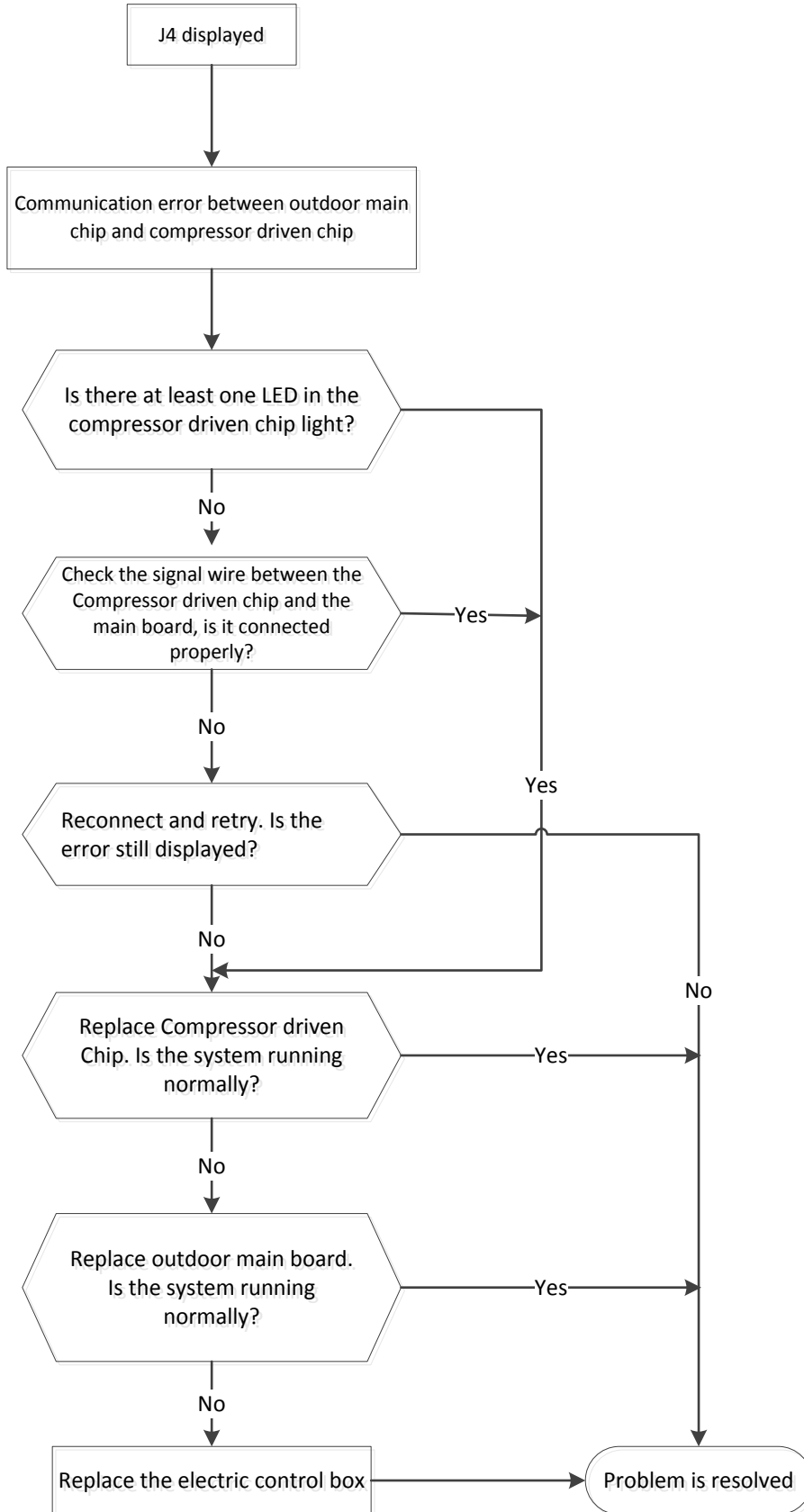

16.4.17. J5 Malfunction

Malfunction conditions	If the sampling voltage is not 5V, the LED displays a failure code.
Possible causes	<ul style="list-style-type: none"> ● Wiring mistakes ● Faulty overload protector ● System blockages ● Faulty outdoor PCB

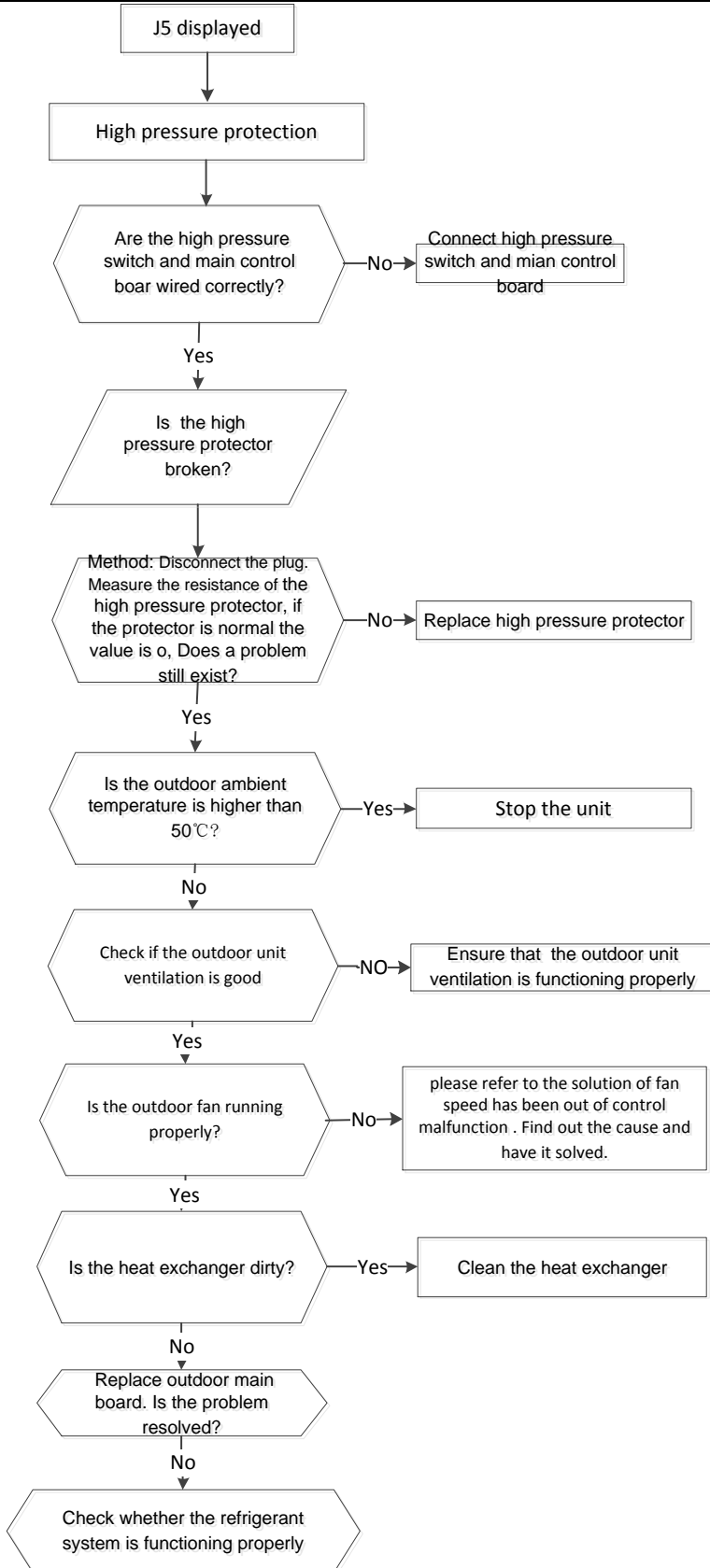

16.4.18. J6/P6 Malfunction

Malfunction conditions	If the sampling voltage is not 5V, the LED displays a failure code.
Possible causes	<ul style="list-style-type: none"> ● Wiring mistake ● Faulty over load protector ● System blockages ● Faulty outdoor PCB

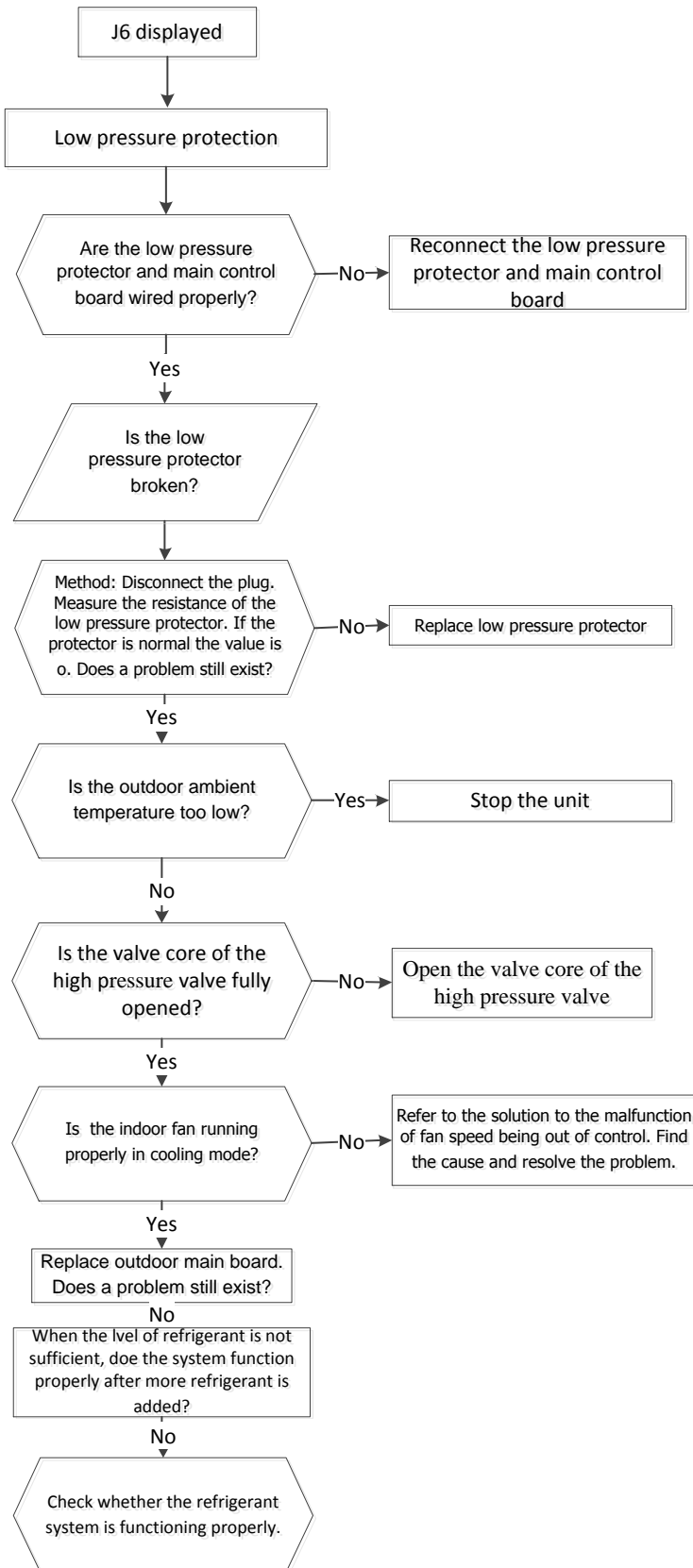

16.4.19. J8 malfunction

Malfunction conditions	decision	An abnormal voltage rise or drop is detected by checking the specified voltage detection circuit.
Supposed causes		<ul style="list-style-type: none">● Abnormal power supply● Wiring mistake● Faulty bridge rectifier● Faulty IPM board

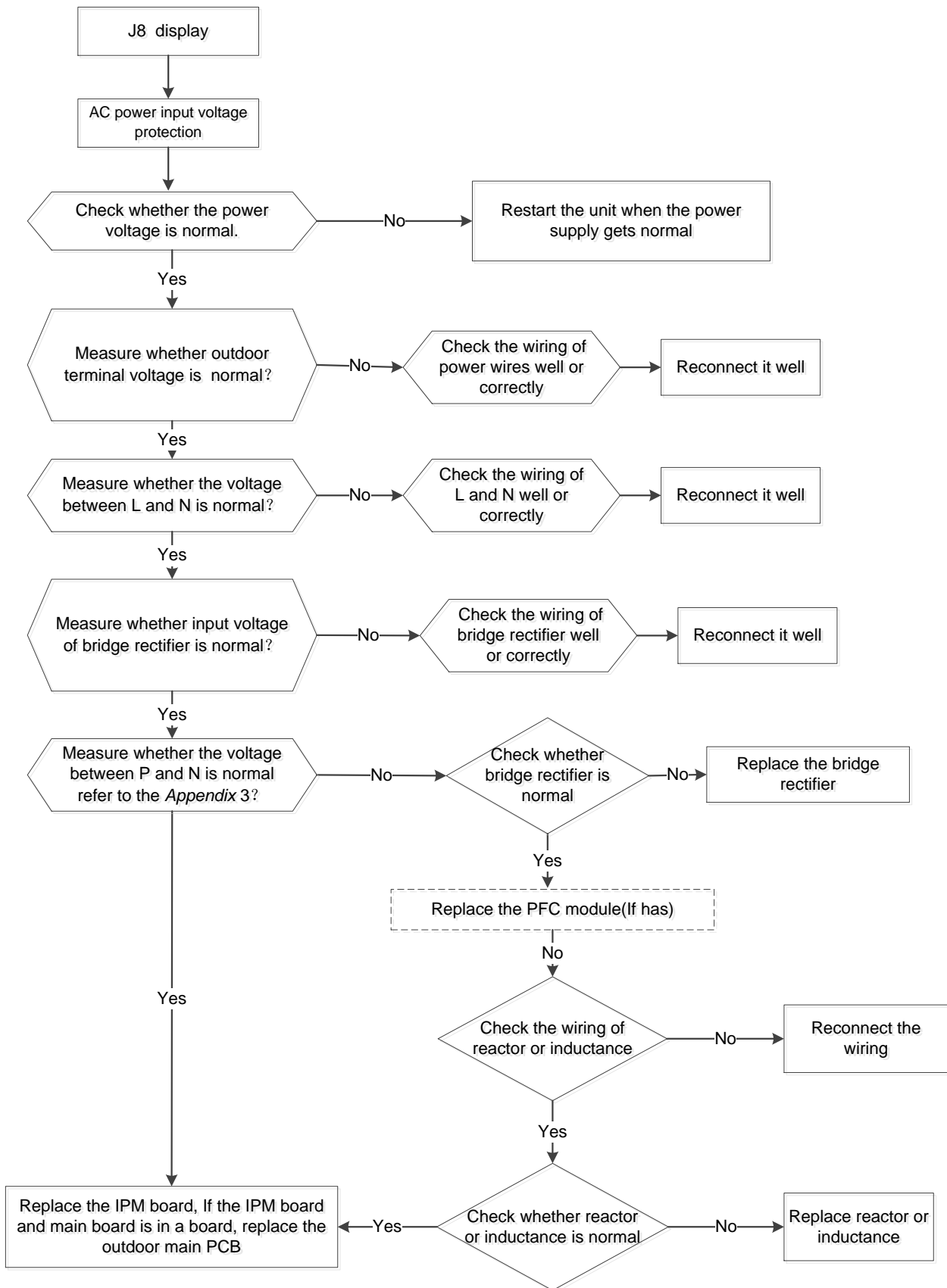

16.4.20 Communication Malfunction between Indoor Unit and auto-lifting Panel (F7)

Malfunction decision conditions	Indoor PCB does not get the feedback from the PCB of auto lifting-panel
Possible causes	<ul style="list-style-type: none"> ● Wiring mistake between indoor PCB and auto-lifting panel ● Faulty PCB of auto-lifting panel ● Faulty indoor PCB

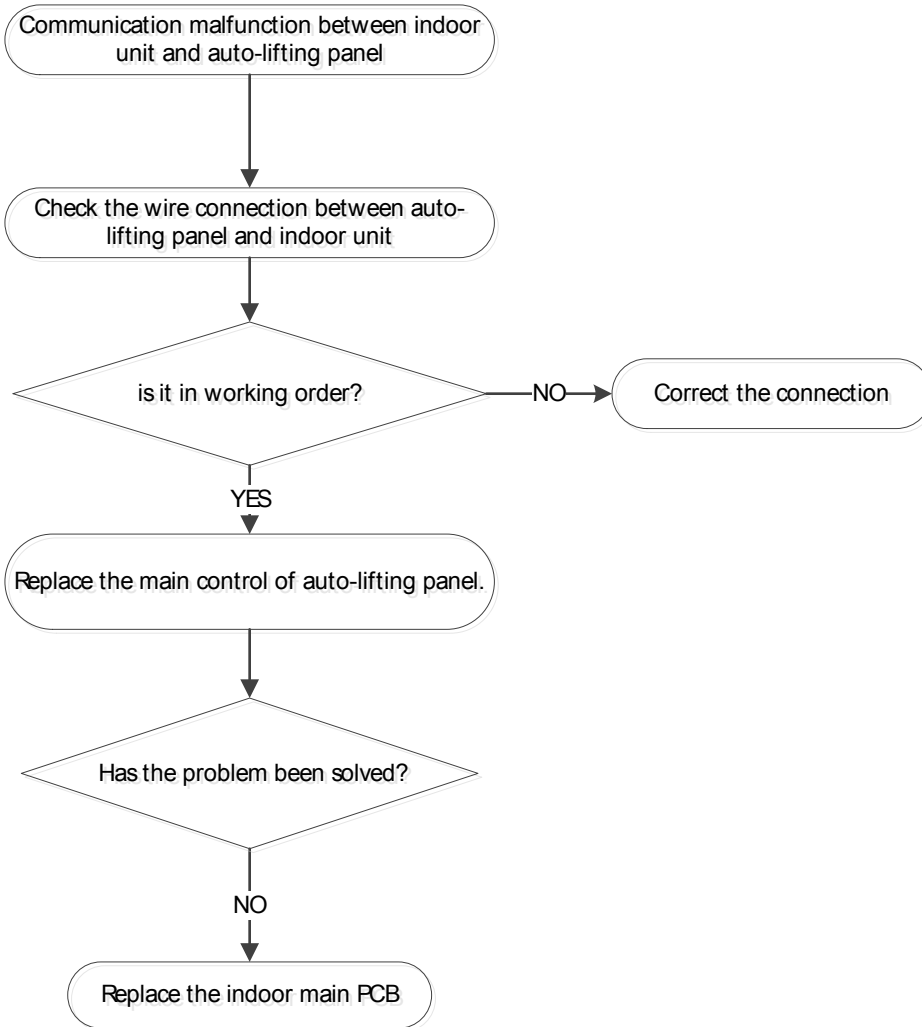

16.4.21 Auto-lifting panel malfunction(F8)

Malfunction decision conditions	Indoor PCB does not get the right close position from the PCB of auto lifting-panel when the panel motor stops
Possible causes	<ul style="list-style-type: none"> ● Wiring mistake between indoor PCB and auto-lifting panel ● Faulty PCB of auto-lifting panel ● Faulty indoor PCB

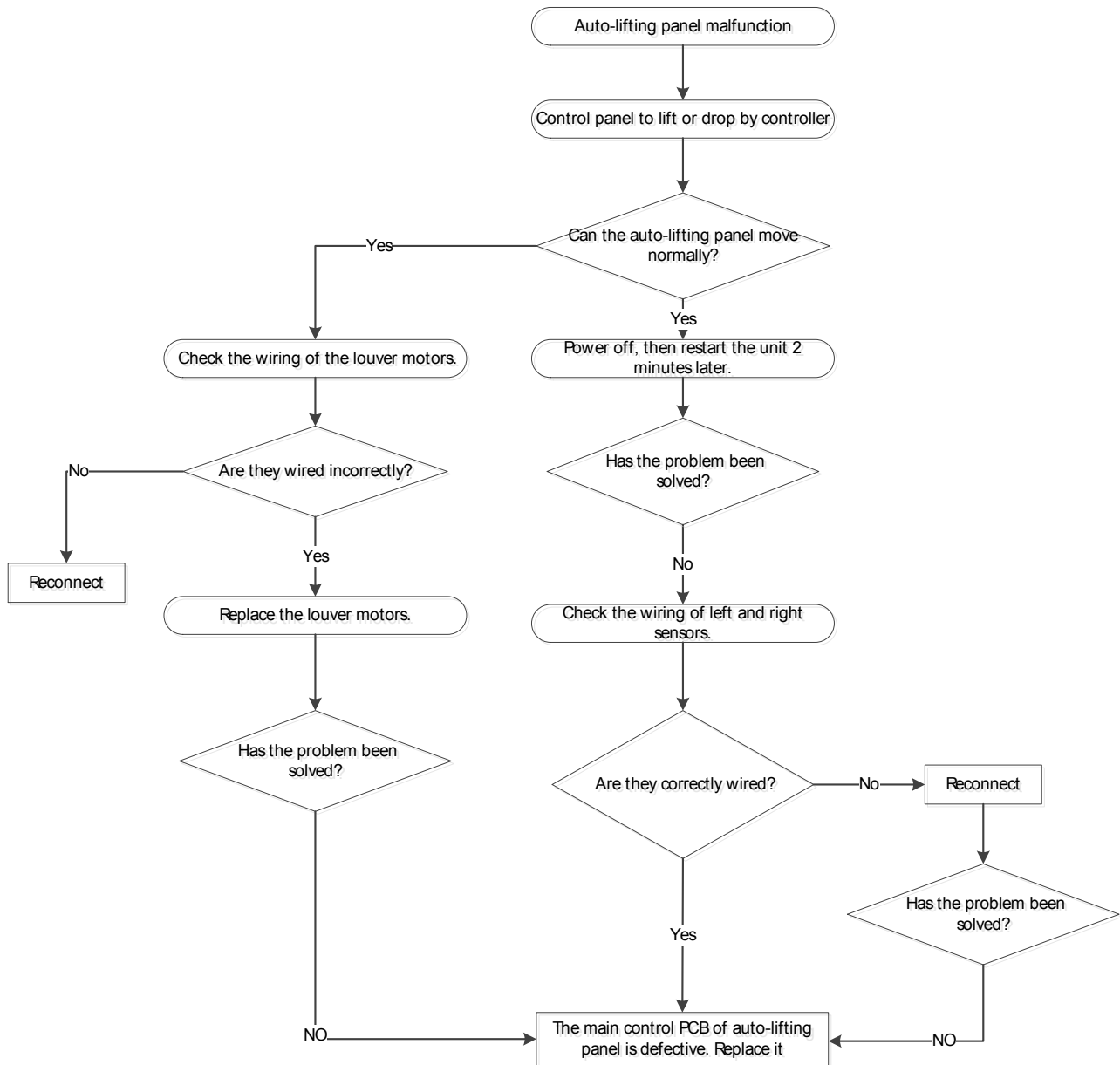

16.4.22 Overcurrent Protection (F0)

Malfunction decision conditions	If the outdoor current exceeds the current limit value, the LED displays a failure code.
Possible causes	<ul style="list-style-type: none">● Wiring mistakes● Faulty bridge rectifier● System blockages● Faulty outdoor PCB

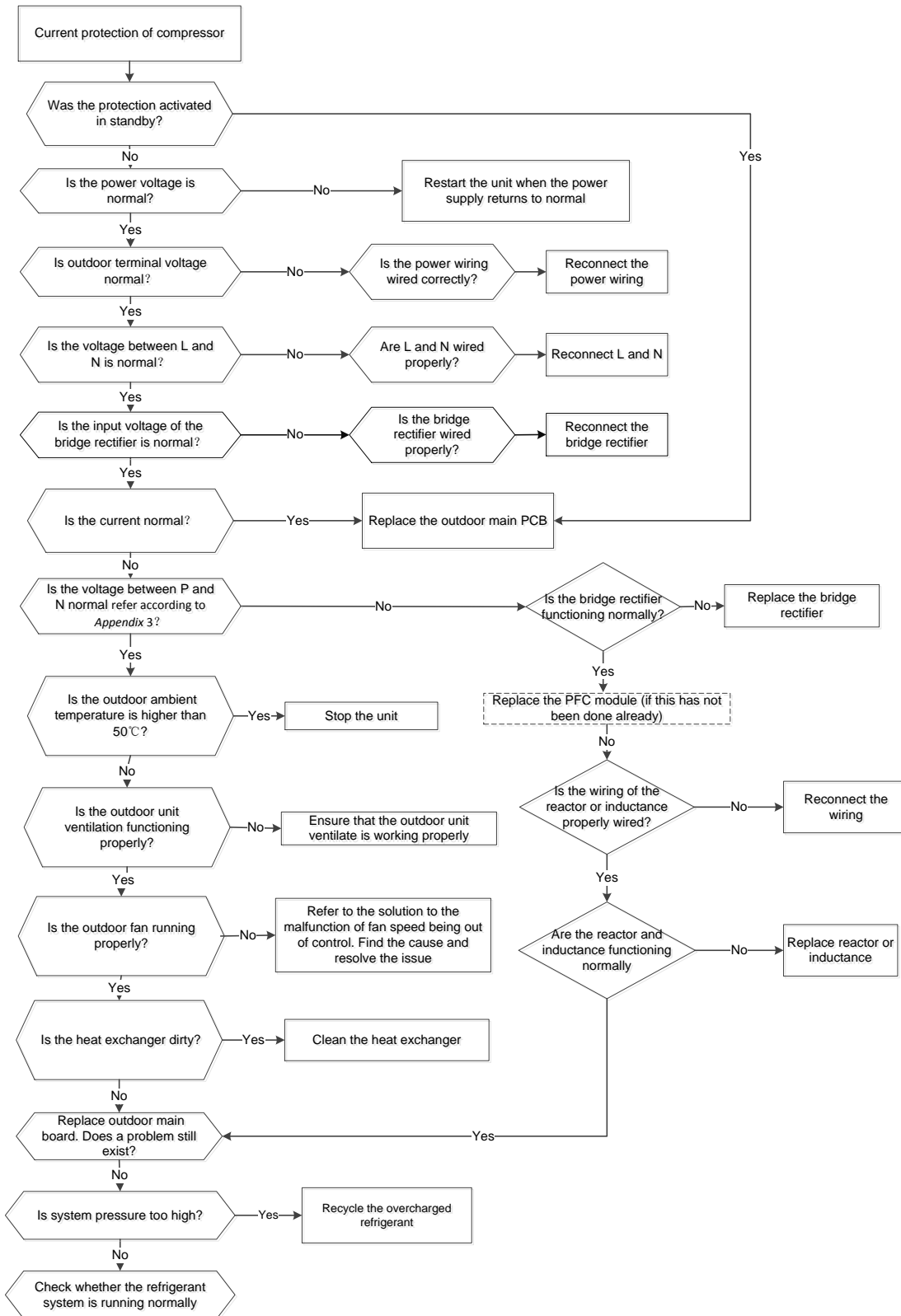

16.5 Main parts check

1. Temperature sensor checking

Disconnect the temperature sensor from PCB, measure the resistance value with a tester.

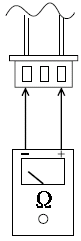

Tester

Temperature Sensors.

Room temp.(T1) sensor,

Indoor coil temp.(T2) sensor,

Outdoor coil temp.(T3) sensor,

Outdoor ambient temp.(T4) sensor,

Compressor discharge temp.(T5) sensor.

Measure the resistance value of each winding by using the multi-meter.

Appendix 1 Temperature Sensor Resistance Value Table for T1,T2,T3,T4 (°C--K)

°C	°F	K Ohm	°C	°F	K Ohm	°C	°F	K Ohm	°C	°F	K Ohm
-20	-4	115.266	20	68	12.6431	60	140	2.35774	100	212	0.62973
-19	-2	108.146	21	70	12.0561	61	142	2.27249	101	214	0.61148
-18	0	101.517	22	72	11.5	62	144	2.19073	102	216	0.59386
-17	1	96.3423	23	73	10.9731	63	145	2.11241	103	217	0.57683
-16	3	89.5865	24	75	10.4736	64	147	2.03732	104	219	0.56038
-15	5	84.219	25	77	10	65	149	1.96532	105	221	0.54448
-14	7	79.311	26	79	9.55074	66	151	1.89627	106	223	0.52912
-13	9	74.536	27	81	9.12445	67	153	1.83003	107	225	0.51426
-12	10	70.1698	28	82	8.71983	68	154	1.76647	108	226	0.49989
-11	12	66.0898	29	84	8.33566	69	156	1.70547	109	228	0.486
-10	14	62.2756	30	86	7.97078	70	158	1.64691	110	230	0.47256
-9	16	58.7079	31	88	7.62411	71	160	1.59068	111	232	0.45957
-8	18	56.3694	32	90	7.29464	72	162	1.53668	112	234	0.44699
-7	19	52.2438	33	91	6.98142	73	163	1.48481	113	235	0.43482
-6	21	49.3161	34	93	6.68355	74	165	1.43498	114	237	0.42304
-5	23	46.5725	35	95	6.40021	75	167	1.38703	115	239	0.41164
-4	25	44	36	97	6.13059	76	169	1.34105	116	241	0.4006
-3	27	41.5878	37	99	5.87359	77	171	1.29078	117	243	0.38991
-2	28	39.8239	38	100	5.62961	78	172	1.25423	118	244	0.37956
-1	30	37.1988	39	102	5.39689	79	174	1.2133	119	246	0.36954
0	32	35.2024	40	104	5.17519	80	176	1.17393	120	248	0.35982
1	34	33.3269	41	106	4.96392	81	178	1.13604	121	250	0.35042
2	36	31.5635	42	108	4.76253	82	180	1.09958	122	252	0.3413
3	37	29.9058	43	109	4.5705	83	181	1.06448	123	253	0.33246
4	39	28.3459	44	111	4.38736	84	183	1.03069	124	255	0.3239
5	41	26.8778	45	113	4.21263	85	185	0.99815	125	257	0.31559
6	43	25.4954	46	115	4.04589	86	187	0.96681	126	259	0.30754
7	45	24.1932	47	117	3.88673	87	189	0.93662	127	261	0.29974
8	46	22.5662	48	118	3.73476	88	190	0.90753	128	262	0.29216
9	48	21.8094	49	120	3.58962	89	192	0.8795	129	264	0.28482
10	50	20.7184	50	122	3.45097	90	194	0.85248	130	266	0.2777
11	52	19.6891	51	124	3.31847	91	196	0.82643	131	268	0.27078
12	54	18.7177	52	126	3.19183	92	198	0.80132	132	270	0.26408
13	55	17.8005	53	127	3.07075	93	199	0.77709	133	271	0.25757
14	57	16.9341	54	129	2.95896	94	201	0.75373	134	273	0.25125
15	59	16.1156	55	131	2.84421	95	203	0.73119	135	275	0.24512
16	61	15.3418	56	133	2.73823	96	205	0.70944	136	277	0.23916
17	63	14.6181	57	135	2.63682	97	207	0.68844	137	279	0.23338
18	64	13.918	58	136	2.53973	98	208	0.66818	138	280	0.22776

19	66	13.2631	59	138	2.44677	99	210	0.64862	139	282	0.22231
----	----	---------	----	-----	---------	----	-----	---------	-----	-----	---------

Appendix 2 Temperature Sensor Resistance Value Table for T5,TH (°C--K)

°C	°F	K Ohm	°C	°F	K Ohm	°C	°F	K Ohm	°C	°F	K Ohm
-20	-4	542.7	20	68	68.66	60	140	13.59	100	212	3.702
-19	-2	511.9	21	70	65.62	61	142	13.11	101	214	3.595
-18	0	483	22	72	62.73	62	144	12.65	102	216	3.492
-17	1	455.9	23	73	59.98	63	145	12.21	103	217	3.392
-16	3	430.5	24	75	57.37	64	147	11.79	104	219	3.296
-15	5	406.7	25	77	54.89	65	149	11.38	105	221	3.203
-14	7	384.3	26	79	52.53	66	151	10.99	106	223	3.113
-13	9	363.3	27	81	50.28	67	153	10.61	107	225	3.025
-12	10	343.6	28	82	48.14	68	154	10.25	108	226	2.941
-11	12	325.1	29	84	46.11	69	156	9.902	109	228	2.86
-10	14	307.7	30	86	44.17	70	158	9.569	110	230	2.781
-9	16	291.3	31	88	42.33	71	160	9.248	111	232	2.704
-8	18	275.9	32	90	40.57	72	162	8.94	112	234	2.63
-7	19	261.4	33	91	38.89	73	163	8.643	113	235	2.559
-6	21	247.8	34	93	37.3	74	165	8.358	114	237	2.489
-5	23	234.9	35	95	35.78	75	167	8.084	115	239	2.422
-4	25	222.8	36	97	34.32	76	169	7.82	116	241	2.357
-3	27	211.4	37	99	32.94	77	171	7.566	117	243	2.294
-2	28	200.7	38	100	31.62	78	172	7.321	118	244	2.233
-1	30	190.5	39	102	30.36	79	174	7.086	119	246	2.174
0	32	180.9	40	104	29.15	80	176	6.859	120	248	2.117
1	34	171.9	41	106	28	81	178	6.641	121	250	2.061
2	36	163.3	42	108	26.9	82	180	6.43	122	252	2.007
3	37	155.2	43	109	25.86	83	181	6.228	123	253	1.955
4	39	147.6	44	111	24.85	84	183	6.033	124	255	1.905
5	41	140.4	45	113	23.89	85	185	5.844	125	257	1.856
6	43	133.5	46	115	22.89	86	187	5.663	126	259	1.808
7	45	127.1	47	117	22.1	87	189	5.488	127	261	1.762
8	46	121	48	118	21.26	88	190	5.32	128	262	1.717
9	48	115.2	49	120	20.46	89	192	5.157	129	264	1.674
10	50	109.8	50	122	19.69	90	194	5	130	266	1.632
11	52	104.6	51	124	18.96	91	196	4.849			
12	54	99.69	52	126	18.26	92	198	4.703			
13	55	95.05	53	127	17.58	93	199	4.562			
14	57	90.66	54	129	16.94	94	201	4.426			
15	59	86.49	55	131	16.32	95	203	4.294			
16	61	82.54	56	133	15.73	96	205	4.167			
17	63	78.79	57	135	15.16	97	207	4.045			
18	64	75.24	58	136	14.62	98	208	3.927			
19	66	71.86	59	138	14.09	99	210	3.812			

Appendix 3:

°C	10	11	12	13	14	15	16	17	18	19	20	21	22
°F	48	50	52	54	56	58	60	62	64	66	68	70	72
°C	23	24	25	26	27	28	29	30	31	32	33	34	35
°F	74	76	78	80	82	84	86	88	90	92	94	96	98

2. Compressor checking

Measure the resistance value of each winding by using the tester.

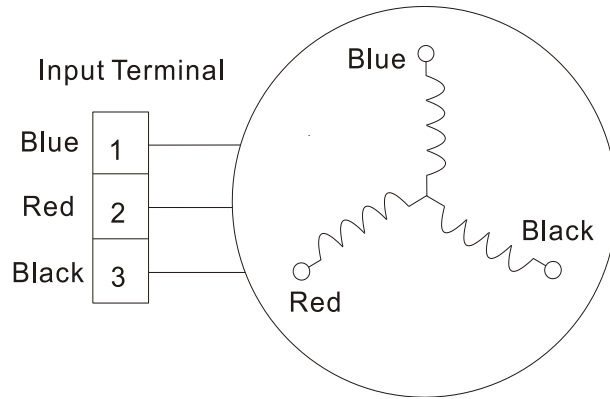

Position	Resistance Value						
	ASN98D22UFZ	ASM135D23UFZ	ATF235D22UMT	ATF250D22UMT	ATF310D43UMT	ATQ420D1UMU	ATM115D43UFZ2
Blue - Red	1.57Ω	1.75 Ω	0.75 Ω	0.75 Ω	0.65 Ω	0.38Ω	1.87Ω
Blue - Black							
Red - Blue							



3. IPM continuity check

Turn off the power, let the large capacity electrolytic capacitors discharge completely, and dismount the IPM. Use a digital tester to measure the resistance between P and UVWN; UVW and N.

Digital tester		Normal resistance value	Digital tester		Normal resistance value
(+)Red	(-)Black		(+)Red	(-)Black	
P	N	∞ (Several MΩ)	U	N	∞ (Several MΩ)
	U				
	V				
	W				
	W		(+)Red		

4: Pressure on Service Port

Cooling chart:

COOLING MODE

°F (°C)	Indoor Temp.	Outdoor temp.				
		75 (23.89)	85 (29.44)	95 (35)	105 (40.56)	115 (46.11)
BAR	70	8.2	7.8	8.1	8.6	10.1
BAR	75	8.6	8.3	8.7	9.1	10.7
BAR	80	9.3	8.9	9.1	9.6	11.2

PSI	70	119	113	117	125	147
PSI	75	124	120	126	132	155
PSI	80	135	129	132	140	162

MPA	70	0.82	0.78	0.81	0.86	1.01
MPA	75	0.86	0.83	0.87	0.91	1.07
MPA	80	0.93	0.89	0.91	0.96	1.12

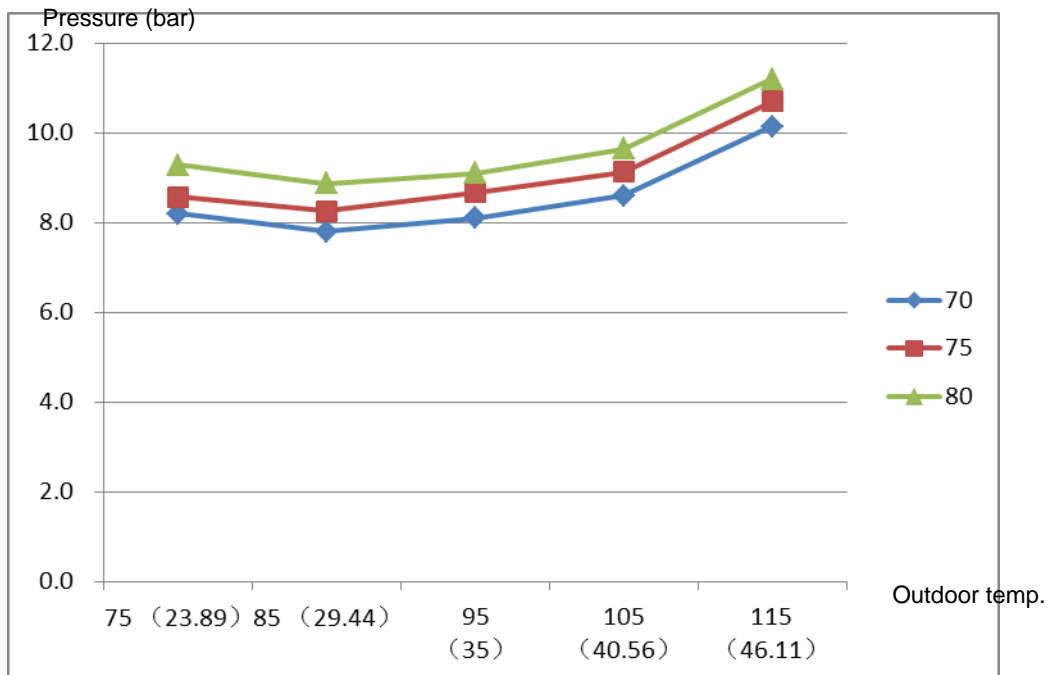

Heating Chart:

HEATING MODE

°F (°C)	Indoor Temp.	Outdoor temp.				
		57 (13.89)	47 (8.33)	37 (2.78)	27 (-2.78)	17 (-8.33)
BAR	55	30.3	28.5	25.3	22.8	20.8
BAR	65	32.5	30.0	26.6	25.4	23.3
BAR	75	33.8	31.5	27.8	26.3	24.9

PSI	55	439	413	367	330	302
PSI	65	471	435	386	368	339
PSI	75	489	457	403	381	362

MPA	55	3.03	2.85	2.53	2.28	2.08
MPA	65	3.25	3.00	2.66	2.54	2.33
MPA	75	3.38	3.15	2.78	2.63	2.49

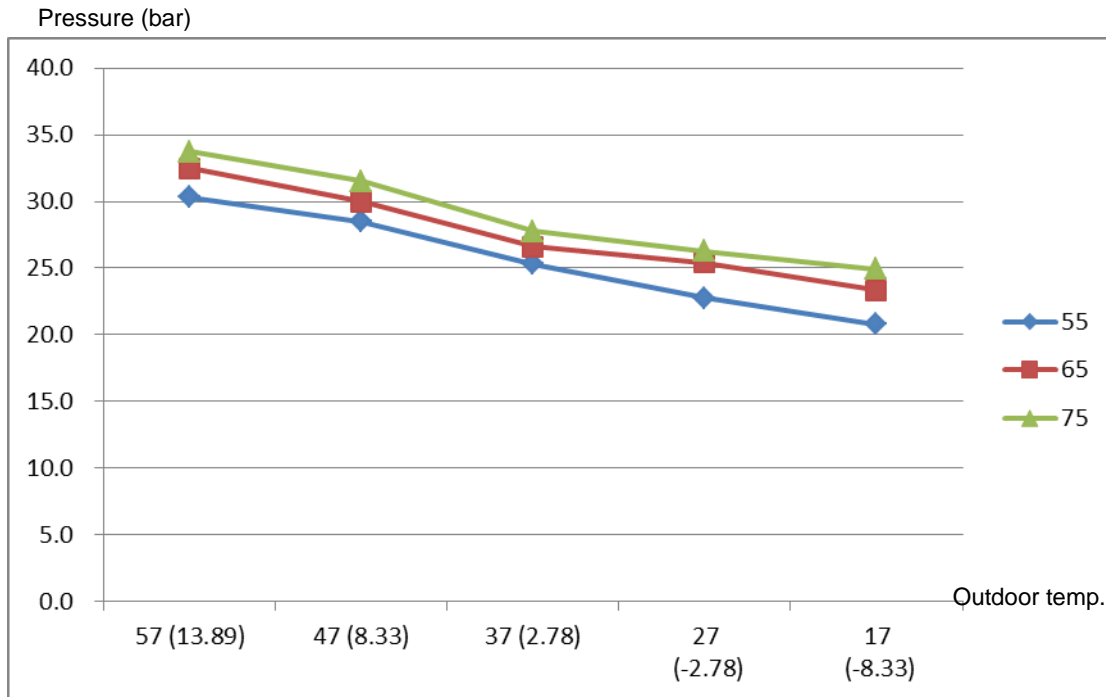





17. Disassembly Instructions



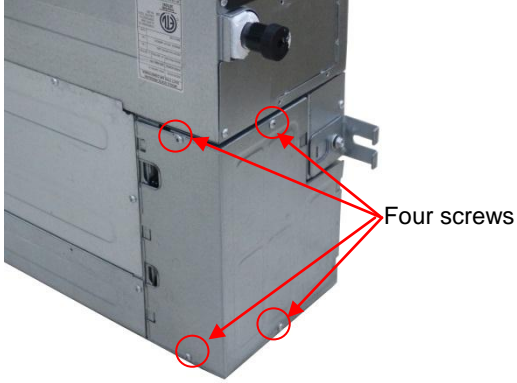
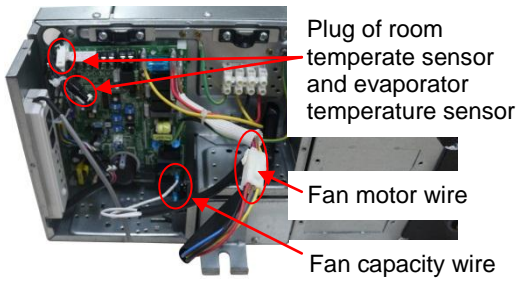
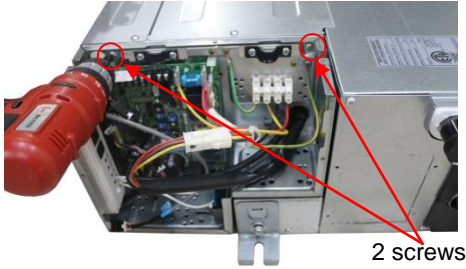
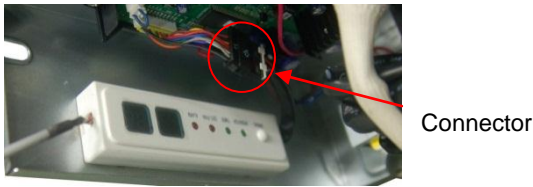

Note: This part is for reference, the photos may have slight difference with your machine.

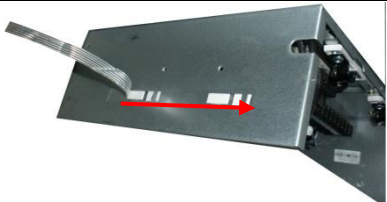

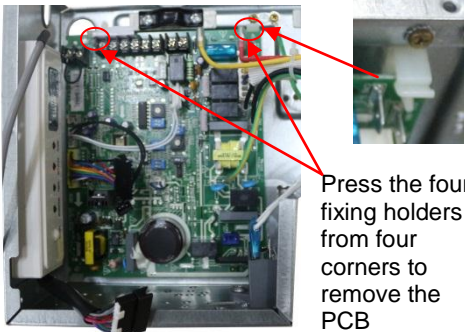
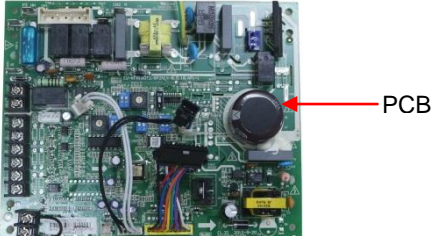
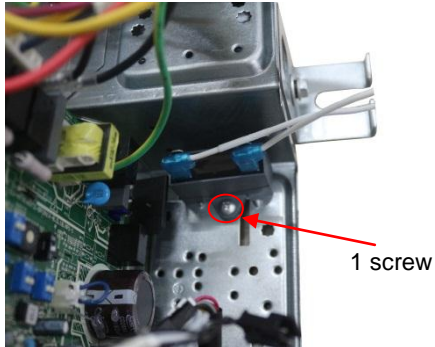
17.1 Indoor unit

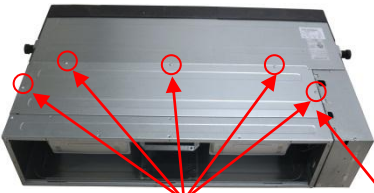
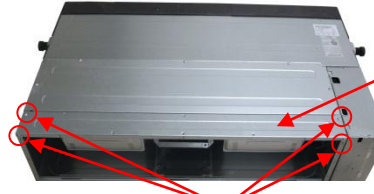

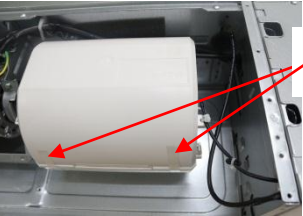
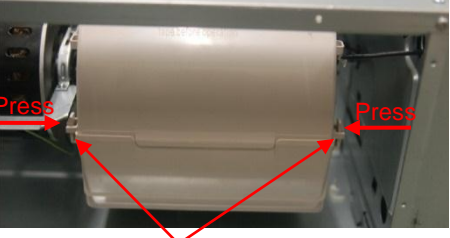
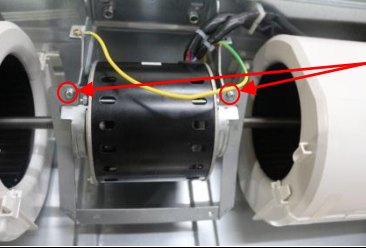
➤ A5 Duct Unit

No.	Parts name	Procedures	Remarks
1	Remove the electronic control box	1) Screw off the screws to remove the cover of electronic control box	 <p>Four screws</p>
		2) Disconnect the fan motor wire, fan capacity wire, room temperature sensor wire and evaporator temperature sensor wire	 <p>Plug of room temperate sensor and evaporator temperature sensor Fan motor wire Fan capacity wire</p>
		3) Screw off the screws to remove electronic control box	 <p>2 screws</p>
2	Remove the display board	1) Remove the cover of electronic control box	Repeat the operation of step1 of No1
		2) Disconnect the display board wire connected to PCB	 <p>Connector</p>
		3) Remove the sticker	 <p>Sticker</p>

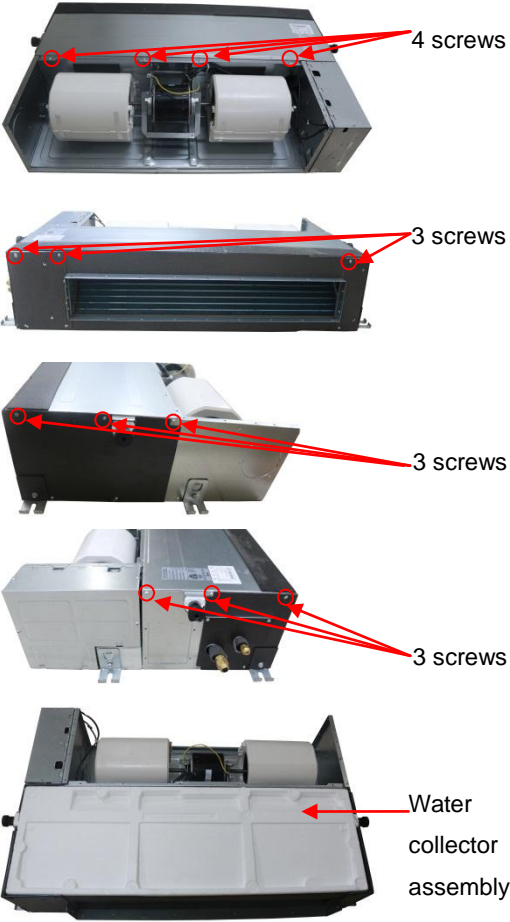

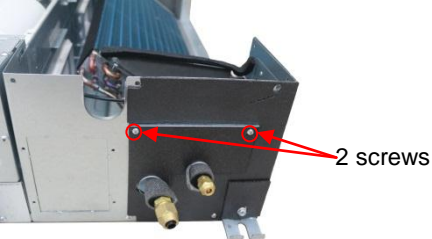
		3) Move the display board according to the arrow direction to disassemble it.	
3	Remove the PCB	1) Remove the cover of electronic control box	Repeat the operation of step1 of No1
		1) Pull out all the plugs or connectors connected to the PCB and remove the ground wire after remove the screw.	
		2) Remove the PCB from the electronic control box	 <p>Press the four fixing holders from four corners to remove the PCB</p>  <p>PCB</p>
4	Remove the fan capacitor	1) Remove the cover of electronic control box	Repeat the operation of step1 of No1
		2) Disconnect the fan capacity wire.	Repeat the operation of step2 of No1
		3) Screw off the screw to remove it	 <p>1 screw</p>

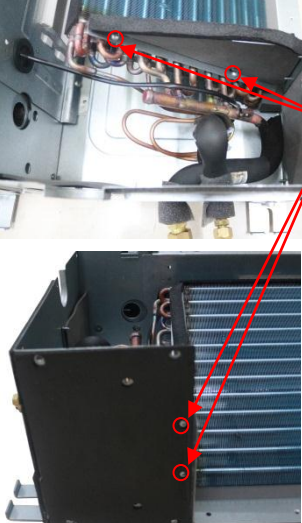
5	Remover the fan motor	1) Screw off the fixing screws to remove the rear cover board	 <p style="text-align: center;">5 screws Rear cover board</p>
		2) Screw off the fixing screws to remove the rear beam	 <p style="text-align: center;">Rear beam Total four screws at the left side and right side</p>
		3) Remove room temperature sensor	 <p style="text-align: right;">Cut off the fastening belt to take off the room temperature sensor</p>
		4) Remove the sticker	 <p style="text-align: right;">Stickers</p>
		5) Remove the below volute shell	 <p style="text-align: center;">Press Press</p> <p style="text-align: center;">Press the clips to take off the volute shell</p>
		6) Remove the fan motor wire from the electronic control box	<p>Refer the operation of step2 of No.1</p>
		7) Disassemble the fan motor fixing clamps to remove the fan motor assembly and fan wheel assembly	 <p style="text-align: right;">The fan motor assembly and fan wheel assembly can be removed after took off the 2screws used to fix the fan motor holder.</p>
		8) Disassemble the fan wheels, then you can remove the fan motor	 <p style="text-align: center;">Take off the screw to remove the fan wheel</p>



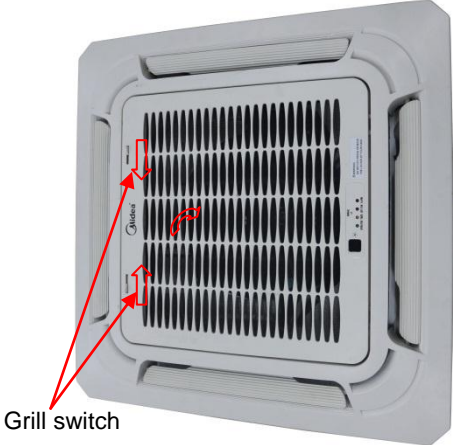

6	Remove the water collector assembly	1) Remove the rear cover board	Repeat the operation of step1 of No.5
		2) Screw off the screws to remove the water collector assembly	 <p>4 screws</p> <p>3 screws</p> <p>3 screws</p> <p>3 screws</p> <p>Water collector assembly</p>
7	Remove the evaporator	1) Remove the water collector	Repeat the operation of No.6
		2) Remove the evaporator sensor	 <p>Evaporator sensor</p>
		3) Remove the pipe clamp board	 <p>2 screws</p>

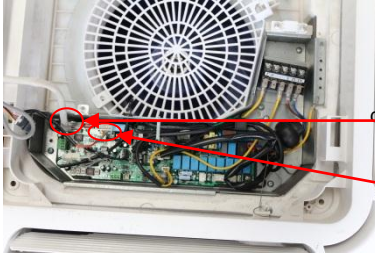
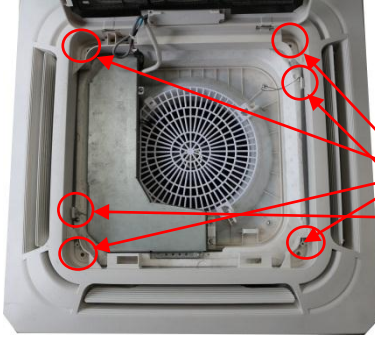

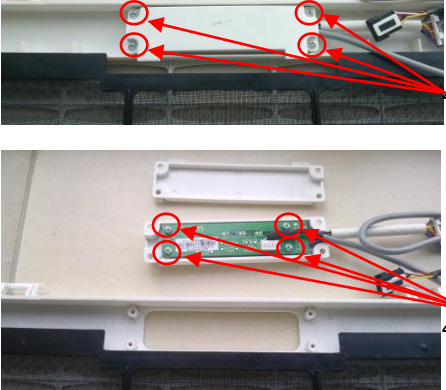
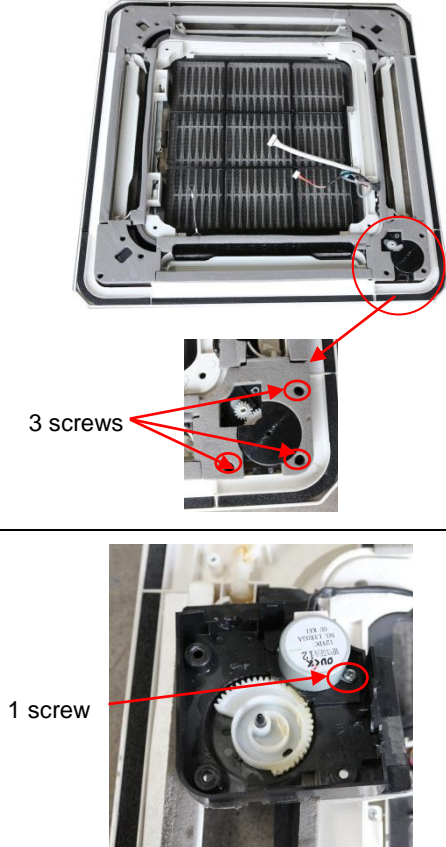
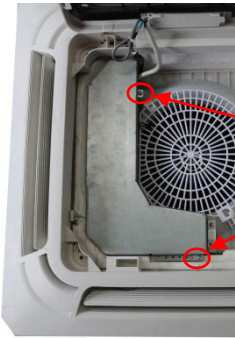
		<p>4) Remove the evaporator support board</p>	 <p>4 screws</p>
		<p>5) Screw off the fixing screws to remove the evaporator</p>	 <p>1 screw</p>

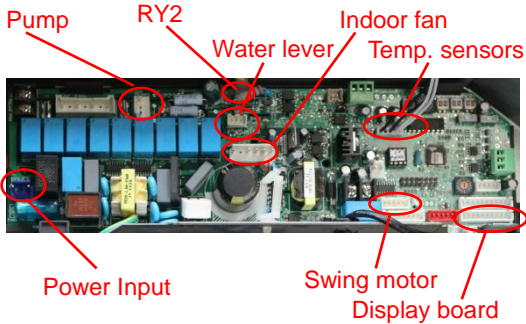

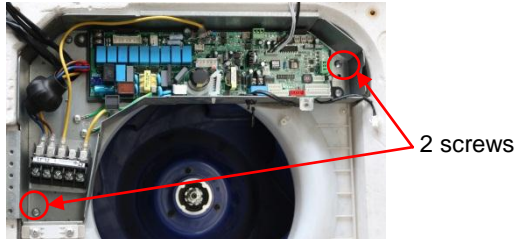
➤ **Cassette Unit**

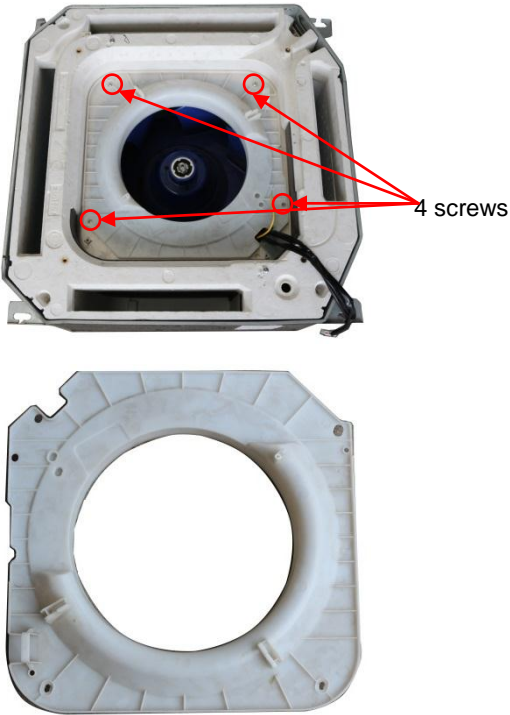

No.	Parts name	Procedures	Remarks
1	Remove the filter	3) Open the grille	
		4) Remove the filter Note: the filter is easy to be damaged, be careful when removing it.	
2	Remove the panel	4) Open the grille 5) Remove the grille <ul style="list-style-type: none"> ● Screw off two screws. ● Disconnect the display board wire and swing motor wire connected to the PCB. ● Remove the grille. 5) Loose the four screws and two wireropes, then the panel can be disassembled.	Repeat the operation of step1 of No.1  <p>2 screws</p>  <p>display board wire swing motor wire</p>  <p>4 screws 2 wireropes</p>
3	Remove the display	1) Open the grille	Repeat the operation of step1 of No.1
		2) Remove the grille	Repeat the operation of step2 of No.2

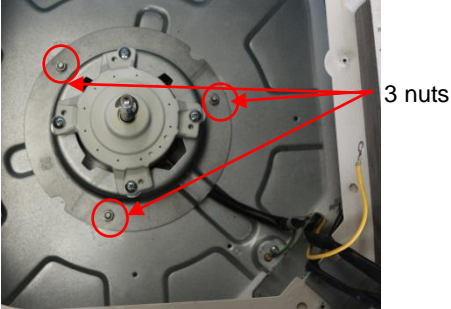
	board	<p>3) Disassemble the display board</p> <ul style="list-style-type: none"> ● Remove the display board cover(4 screws) ● Remove the display board(4 screws) 	 <p>4 screws</p> <p>4 screws</p>
4	Remove the swing motor	<p>1) Remove the panel</p> <p>2) Screw off 3 screws to remove the swing motor assy.</p> <p>3) Screw off 1 screws to remove the swing motor.</p>	<p>Repeat the operation of step1,2,3 of No.2</p>  <p>3 screws</p> <p>1 screw</p>
5	Remove the PCB	<p>1) Open the grille</p> <p>2) Disassemble the electronic control box cover after remove the 2 screws.</p>	<p>Repeat the operation of step1 of No.1(No need to remove the panel)</p>  <p>2 screws</p>

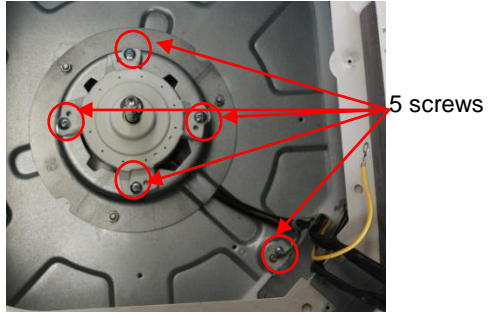
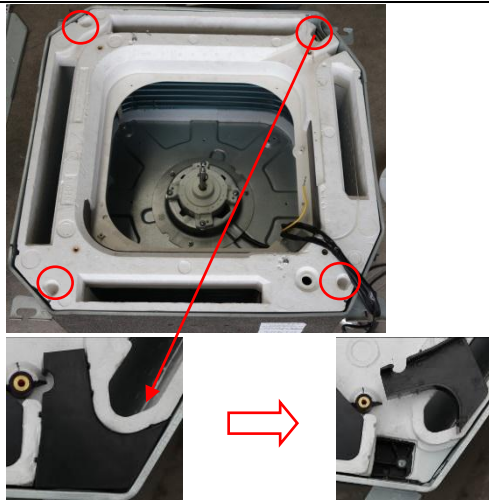
		<p>3) Pull out all the connection wires to other parts, then the PCB can be replaced.</p>	
		<p>4) There are 2 buckles fixing the PCB. To draw out the PCB, you should open them.</p>	
6	Remove the electronic control box	<p>1) Open the grille</p>	<p>Repeat the operation of step1 of No.1 (No need to take down the panel)</p>
		<p>2) Remove the electronic control box cover</p>	<p>Repeat the operation of step 2 of No.5</p>
		<p>3) Pull out all the plugs or connectors connected to the electronic control box</p>	
		<p>4) Remove the electronic control box Remove the 2 screws to disassemble the electronic control box</p>	 
7	Remover the fan	<p>1) Repeat the operation of No.5</p>	

	<p>wheel</p>	<p>2) Remove the ventilation ring Release the 4 screws to disassemble it.</p>	
		<p>3) Remove the fixing nut to disassemble the fan wheel</p>	
		<p>4) Pull out the fan wheel</p>	
<p>8</p>	<p>Remove the fan motor</p>	<p>1) Repeat the operation of No.6</p>	
		<p>2) Remove the fixing board of fan motor wire</p>	

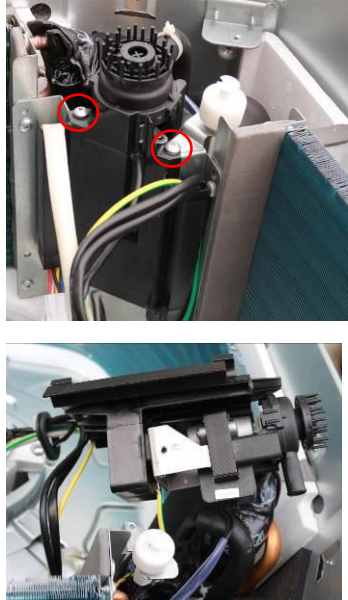

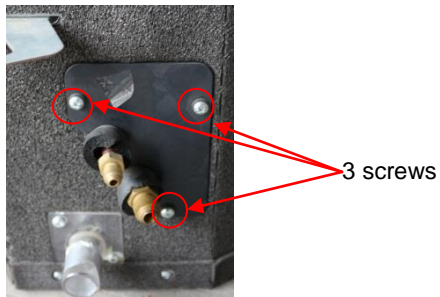
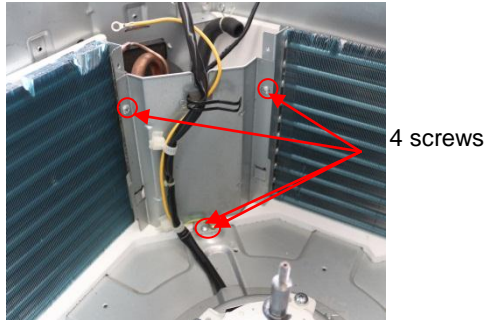
		3) Remove the 5 screws to disassemble the fan motor	
9	Remove the water collecting assembly	6) Remove the panel	Repeat the operation of No.2
		7) Remove the electronic control box	Repeat the operation of No.6
		8) Screw off the 4 screws inside 4 holes (1 is under a protection cover) to remove the water collecting assembly.	
		9) Take out the water collecting assembly	
10	Remove the draining pump	1) Remove the panel	Repeat the operation of No.2
		2) Remove the electronic control box	Repeat the operation of No.6
		3) Remove the water collecting assembly	Repeat the operation of No.9
		4) Disconnect the drain pipe.	

		<p>5) Release 2 screws to remove the pump supporter. Be careful of the connection wires.</p>	
		<p>6) There are 2 screws under the supporter to fixing the pump. Release them to take the pump out of the supporter.</p>	
11	Remove the evaporator	<p>1) Remove the water collecting assembly</p>	Repeat the operation of No.9
		<p>2) Remove the seal board of evaporator</p>	
		<p>3) Remove the evaporator fixing board</p>	

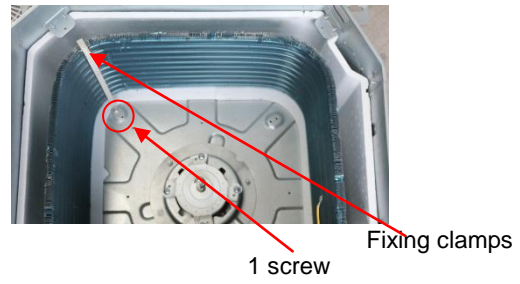

4) Remove the evaporator fixing clamps to disassemble the evaporator.

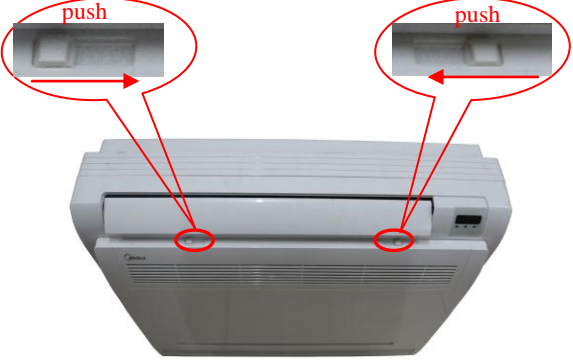
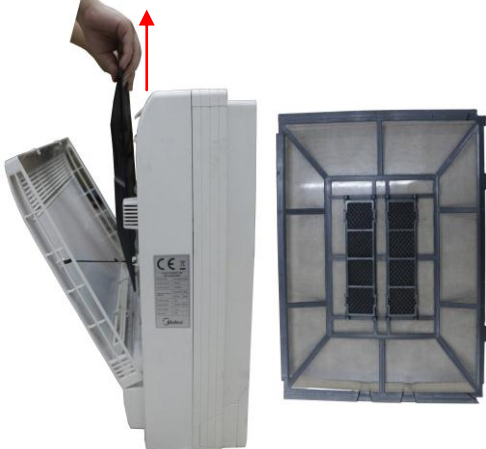

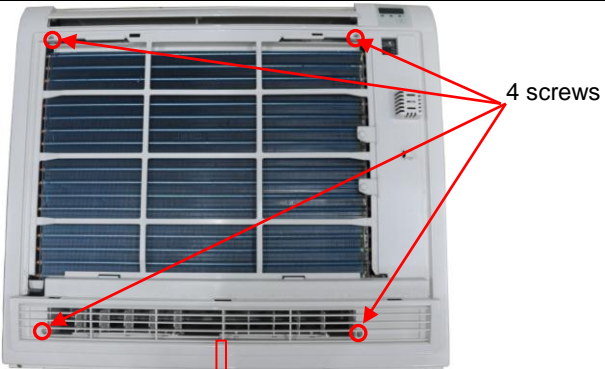

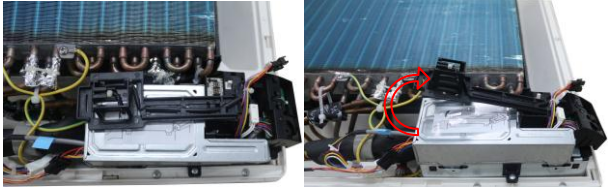
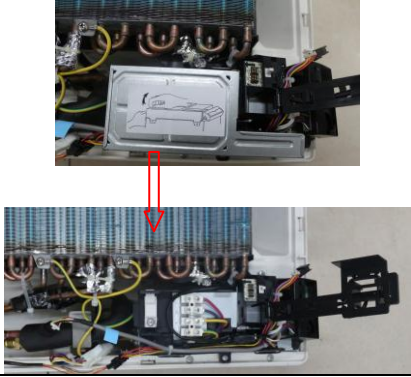
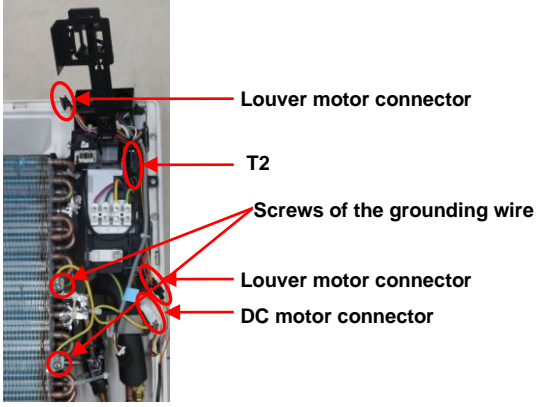

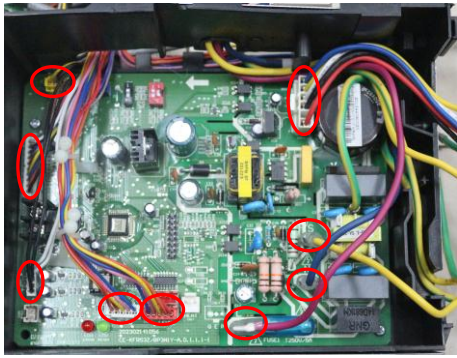
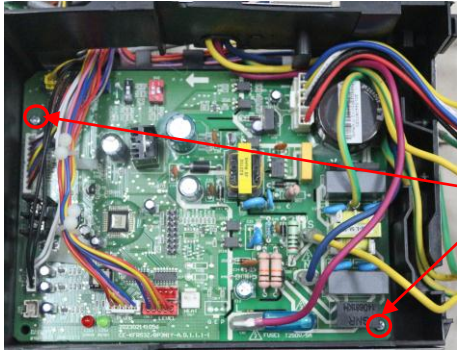

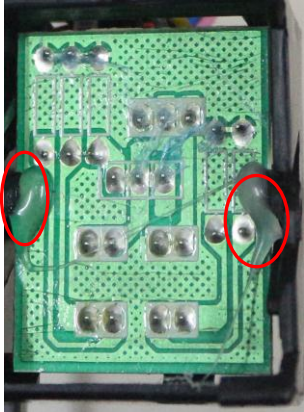

➤ Console Unit

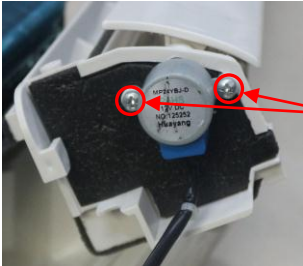
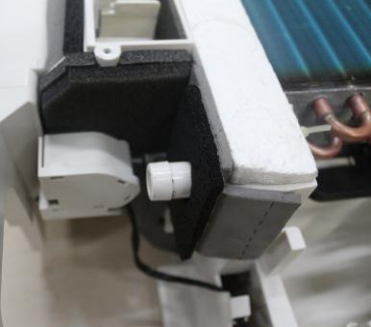
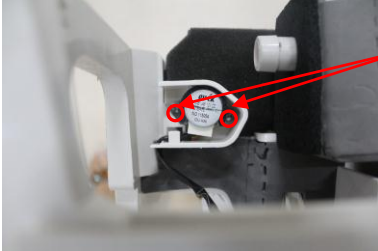

No.	Parts name	Procedures	Remarks
1	Remove the Filter	4) Slide the two stoppers on the left and right sides to open the front panel	
		5) Remove the filter.	
2	Remove the electronic control box	4) Remove the air front panel	<ul style="list-style-type: none"> ● Open the front panel Repeat the operation of step1 of No.1
		5) Remove the filter.	<ul style="list-style-type: none"> ● Remove the string.  <ul style="list-style-type: none"> ● Allowing the front panel to fall forward will enable you to remove it.
		6) Remove four fixing screws to remove the panel frame assembly	<p>Repeat the operation of step 2 of No.1</p>  <p>4 screws</p>

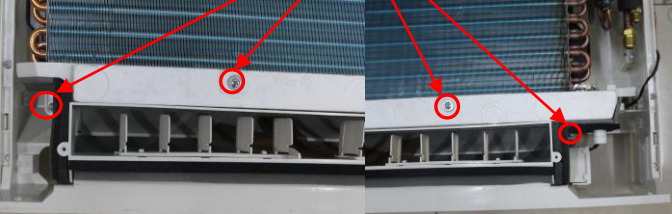
			
		7) Remove the installation plate of electric parts	
		8) Remove the fixing board of electronic control box	
		9) Disconnect the DC motor wire, 2 louver motor wires, evaporator coil temperature sensor(T2) wire, and two grounding wire (yellow-green) to remove the electronic control box	
3	Remove the PCB	6) Take out the electronic control box from the body and remove its cover	Repeat the operation of step1~ step6 of No2.

		7) Disconnect all the wires of plugs connected to the PCB	
		8) Remove two fixing screws to remove the PCB	 2 screws
4.	Remove the display board	1) Remove the electronic control box	Repeat the operation of step1~step of No2.
		2) Remove the fixing glue to remove the display board	
5	Remove the switch board	1) Remove the electronic control box	Repeat the operation of step1~step of No2.
		2) Remove the fixing glue to remove the display board	
7	Remove the air outlet grille assembly	1) Remove the front panel assembly and the panel frame assembly	Repeat the operation of step1, step2 and step3 of No 2.

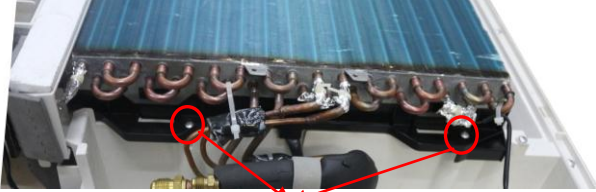

		2) Remove the 1 fixing screw to remove air outlet grille assembly	
		3) Disconnect louver motor wire	
8	Remove the louver motor of air outlet assembly	1) Remove the air outlet grille assembly	Repeat the operation of No.7 to remove the air outlet grille assembly
		2) Screw off the screws to remove the motor	
9	Remove the louver motor of the water collector	1) Remove the front panel assembly and the panel frame assembly	Repeat the operation of step1, step2 and step3 of No 2.
		2) Remove the cover of louver motor	
		3) Screw off the screws to remove the motor	
10	Remove the water collector	3) Remove the front panel assembly and the panel frame assembly	Repeat the operation of step1, step2 and step3 of No 2.

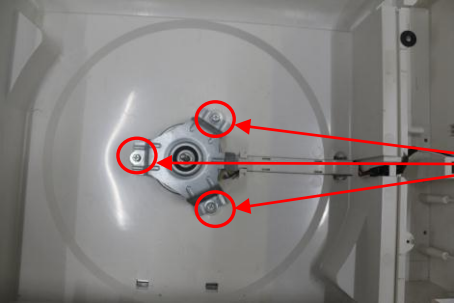

		<p>4) Disconnect louver motor wire</p>	 <p>Louver motor connector</p>
		<p>5) Remove 4 fixing screws to disassemble the water collector</p>	 <p>4 screws</p>  
<p>11</p>	<p>Remove the evaporator assembly</p>	<p>1) Remove the electronic control box</p>	<p>Repeat the operation of No.2 to remove the electronic control box</p>
		<p>2) Remove the air outlet grille assembly</p>	<p>Repeat the operation of No.7 to remove the air outlet grille assembly</p>
		<p>3) Remove the evaporator sensor and release the pipe strap.</p>	
		<p>4) Remove the evaporator assembly</p>	

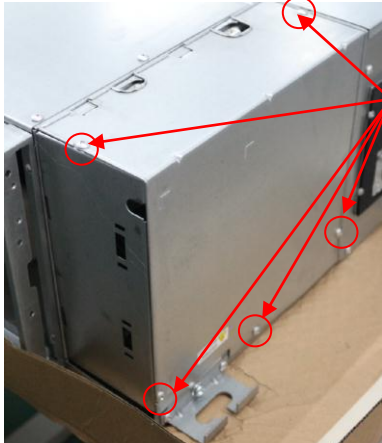
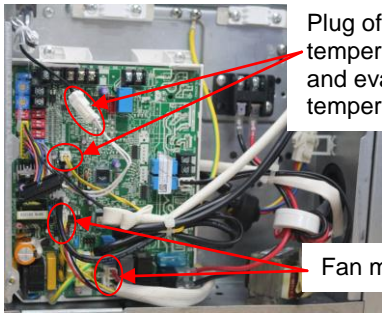
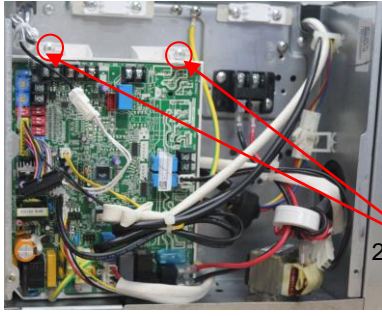
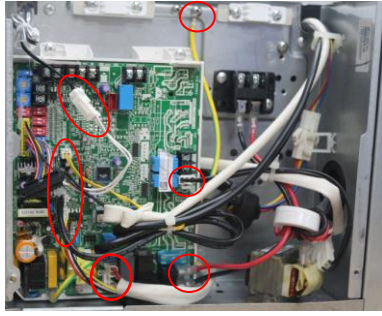

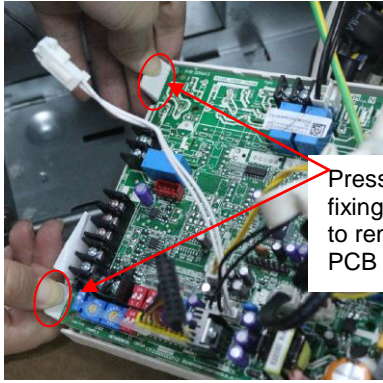
12	Remove the centrifugal fan	1) Remove the electronic control box	Repeat the operation of No.2 to remove the electronic control box
		2) Remove the air outlet grille assembly	Repeat the operation of No.7 to remove the air outlet grille assembly
		3) Remove four fixing screws to remove the ventilation assembly	 <p>Each side has two screws</p>
		4) Remove the hex nut fixing the fan to remove the fan.	
13	Remove the fan motor	5) Remove the centrifugal fan	Repeat the operation of No.12 to remove the centrifugal fan
		6) Remove the fan motor after unfastening three fixing screws.	 <p>3 screws</p>

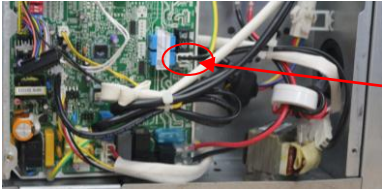
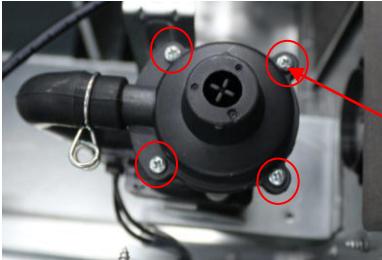
➤ **A6 Duct Unit**

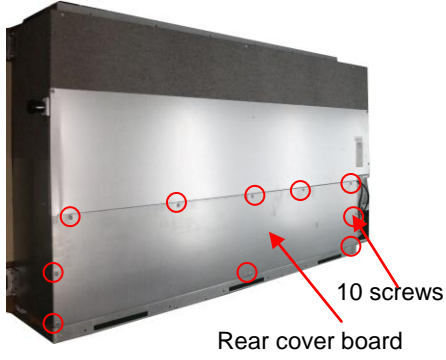
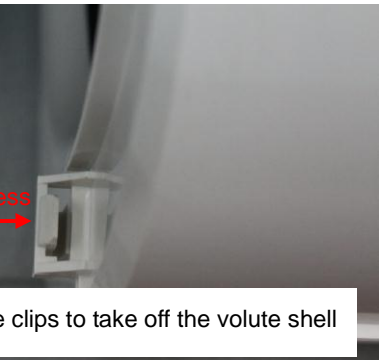
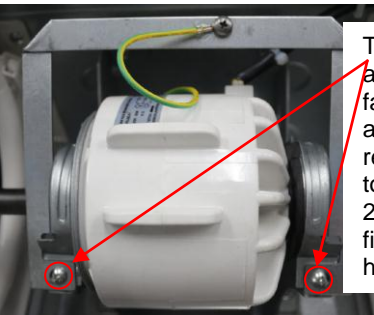
No.	Parts name	Procedures	Remarks
1	Remove the electronic control box	6) Screw off the screws to remove the cover of electronic control box	 <p>Five screws</p>
		7) Disconnect the fan motor wire, room temperature sensor wire and evaporator temperature sensor wire	 <p>Plug of room temperate sensor and evaporator temperature sensor</p> <p>Fan motor wire</p>
		8) Screw off the screws to remove electronic control box	 <p>2 screws</p>
2	Remove the PCB	9) Remove the cover of electronic control box	Repeat the operation of step1 of No1
		2) Pull out all the plugs or connectors connected to the PCB and remove the ground wire after remove the screw.	

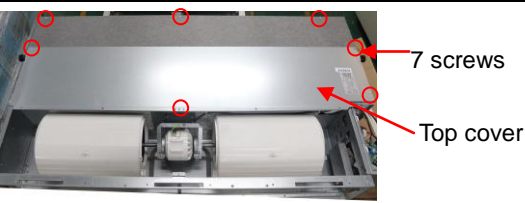
		10) Remove the PCB from the electronic control box	 <p>Press the two fixing holders to remove the PCB</p>
3**	Remove the reactance	6) Remove the cover of electronic control box	Repeat the operation of step1 of No1
		7) Disconnect the reactance wire	 <p>Reactance wire</p>
		8) Screw off the screw to remove it	 <p>1 screw</p>
4**	Remove the drain pump	1) Remove the cover of electronic control box	Repeat the operation of step1 of No1
		2) Disconnect the drain pump wire	 <p>Drain pump wire</p>
		3) Screw off the screws to remove it	 <p>4 screws</p>

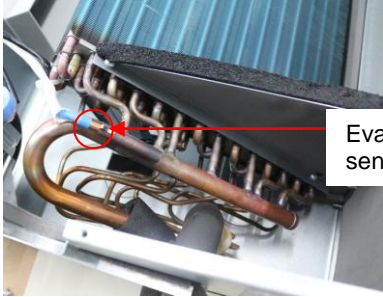
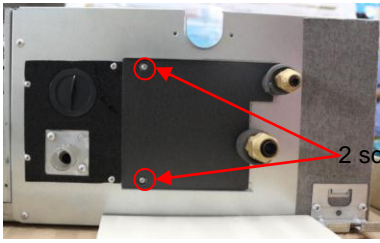
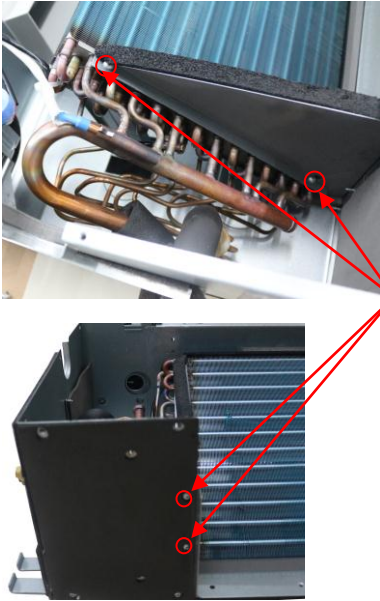

5	Remover the fan motor	9) Screw off the fixing screws to remove the rear cover board	 <p>10 screws Rear cover board</p>
		10) Remove the volute shell	 <p>Press Press the clips to take off the volute shell</p>
		11) Remove the fan motor wire from the electronic control box	Refer the operation of step2 of No.1
		12) Disassemble the fan motor fixing clamps to remove the fan motor assembly and fan wheel assembly	 <p>The fan motor assembly and fan wheel assembly can be removed after took off the 2screws used to fix the fan motor holder.</p>
		13) Disassemble the fan wheels, then you can remove the fan motor	 <p>Take off the screw to remove the fan wheel</p>
6	Remove the water collector assembly	6) Remove the rear cover board	Repeat the operation of step1 of No.5
		7) Screw off the seven screws to remove the top cover, then remove the water collector assembly	 <p>7 screws Top cover</p>

			 <p>Water collector assembly</p>
7	Remove the evaporator	10) Remove the water collector	Repeat the operation of No.6
		11) Remove the evaporator sensor	 <p>Evaporator sensor</p>
		12) Remove the pipe clamp board	 <p>2 screws</p>
		13) Remove the evaporator support board	 <p>4 screws</p>
		14) Screw off the fixing screws to remove the evaporator	 <p>1 screw</p>

** means there is no this part in some models.

17.2 Outdoor unit

➤ MOB01-09HFN1-MW0W, MOB01-12HFN1-MV0W

No.	Part name	Procedures	Remarks
1	Panel plate	<p>How to remove the panel plate.</p> <p>1) Stop operation of the air conditioner and turn "OFF" the power breaker.</p> <p>2) Remove the big handle first, then remove the top cover (3 screws)</p> <p>3) Remove the screws of front panel (6 screws)</p> <p>(4) Remove the screws of the right side panel (6 screws)</p>	<p>Screws of top panel (3 screws, 1 screw is under the big handle)</p>  <p>3 screws of big handle</p> <p>Screws of front panel (6 screws)</p> 
2	Fan ass'y	<p>How to remove the fan ass'y.</p>	

1)After remove the panel plate following procedure 1

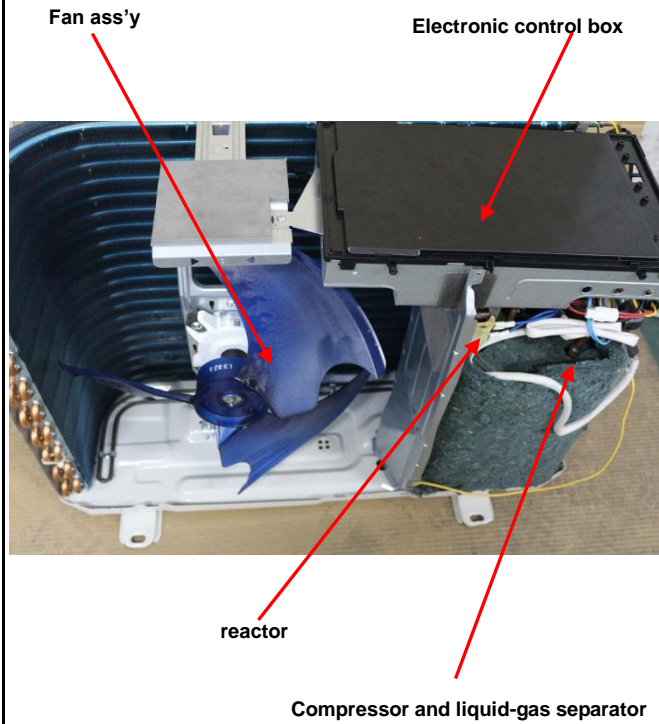

2) Remove the nut fixing the fan, and remove the fan.

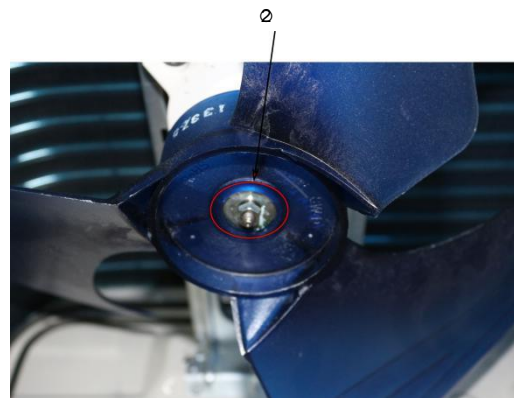

3) Unfix the hooks and then open the electronic control box cover.

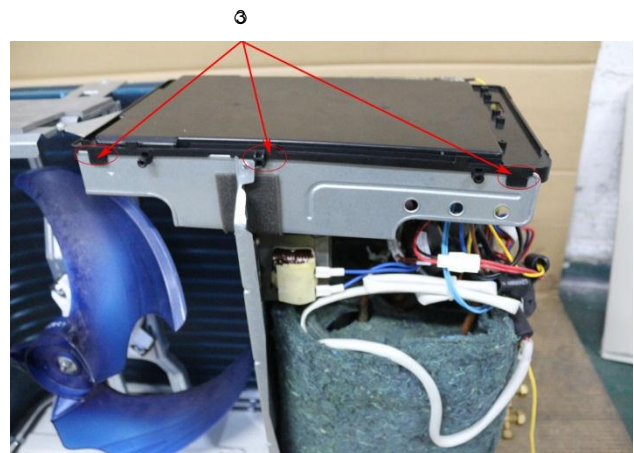

4) Disconnect the connector for fan motor from the electronic control board.



5) Remove the four fixing screws of the fan motor, then remove the motor.

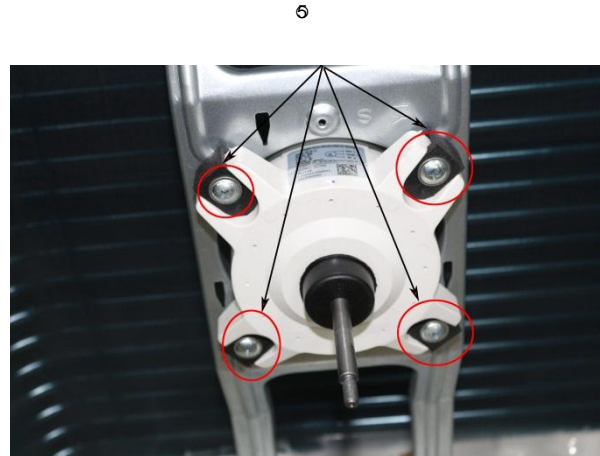
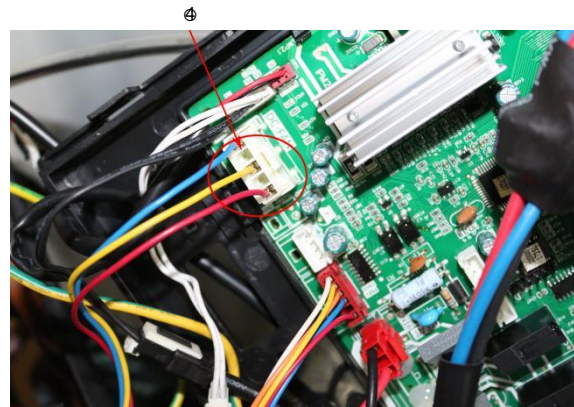

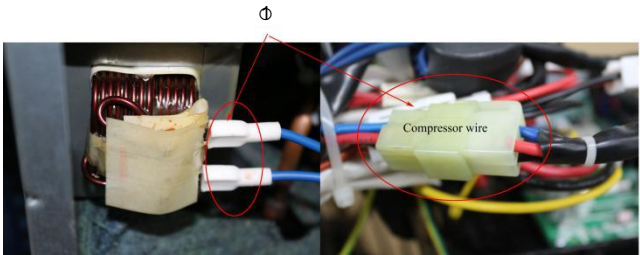
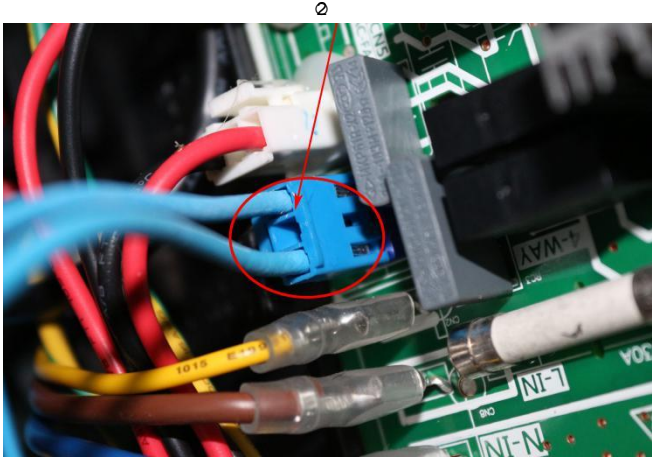
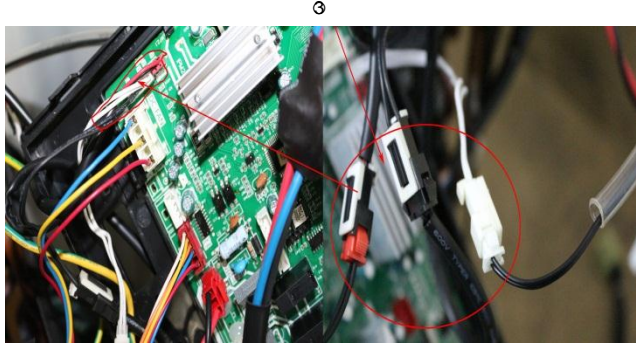
3	Electrical parts	<p>How to remove the electrical parts.</p> <p>3) After finish work of item 1 and item 2, remove the two connectors for the compressor and the reactors.</p> <p>4) Pull out the two blue wires connected with the four way valve.</p> <p>3) Pull out connectors of the compressor top temp. sensor, condenser coil temp. sensor(T3),outdoor ambient temp. sensor(T4) and discharge temp. sensor(T5).</p> <p>4)Disconnect the Compressor crankcase</p>	  
---	------------------	--	---

heater connector.

5) Disconnect the electronic expansion valve wire from the control board

6) Remove the ground wires .

7) Remove the power supply wires(old label, L1,L2,S, new label 1,2,3).

8) Then remove the electronic control box.

④

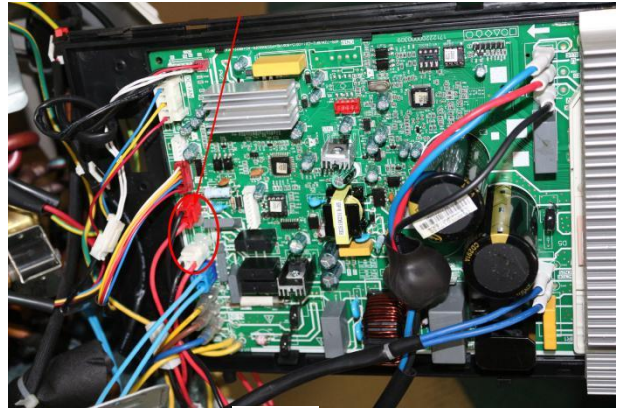

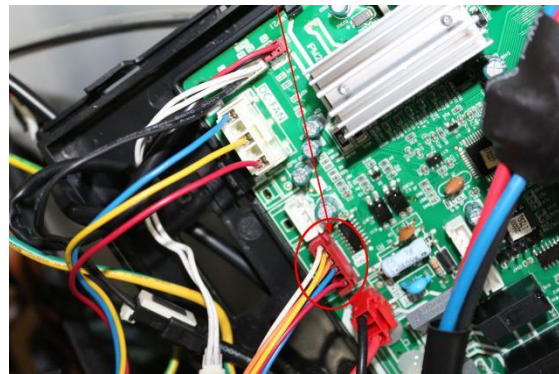

⑤



⑥

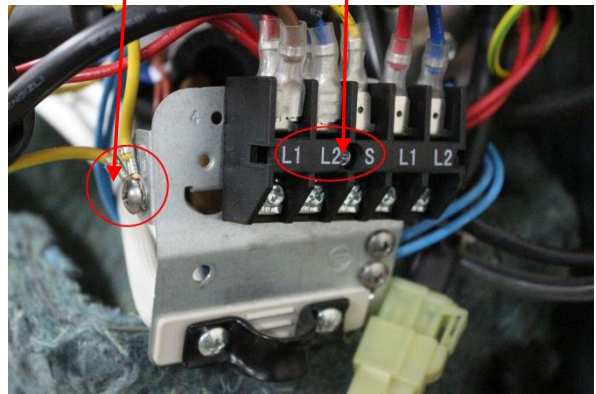

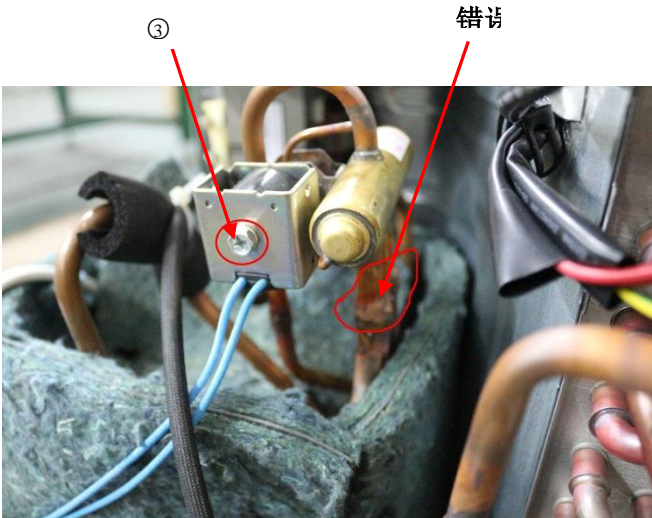
⑦

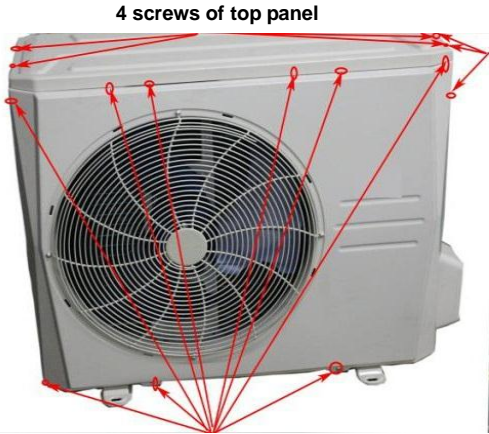
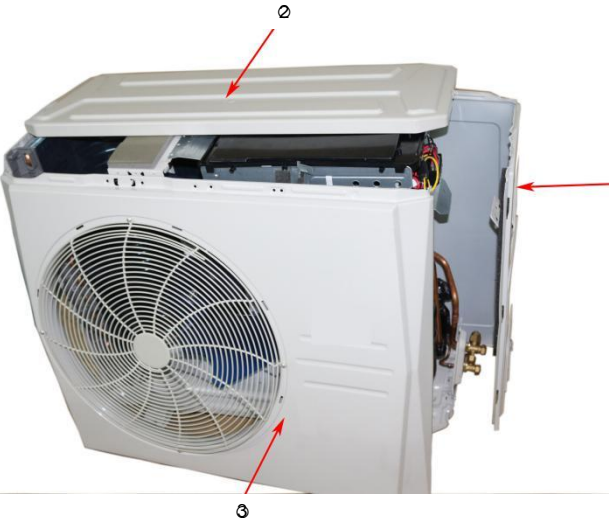

4	Four-way valve	<p>How to remove the four-way valve.</p> <ol style="list-style-type: none"> 1) Perform work of item 1,2,3. 2) Recover refrigerant from the refrigerant circuit. 3) Remove the screw of the coil and then remove the coil. 4) Detach the welded parts of four-way valve and pipe. 5) Then the four-way valve ass'y can be removed 	<p>The picture of four-way valve may be different from the one on your side.</p> 
5	Compressor	<p>How to remove the compressor.</p> <ol style="list-style-type: none"> 1) After perform work of item1,2,3. 2) Remove the discharge pipe and suction pipe with a burner. 3) Remove the hex nuts and washers fixing the compressor on bottom plate. 4) Lift the compressor from the base pan assembly. 	

➤ MOCA01-18HFN1-MT0W

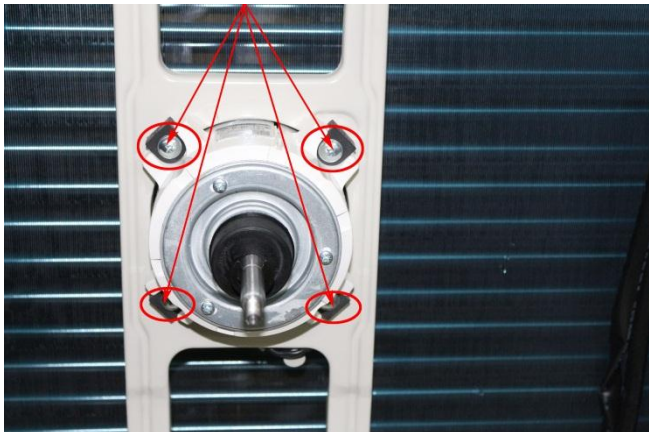
No.	Part name	Procedures	Remarks
	Panel plate	<p>How to remove the panel plate.</p> <p>1) Stop operation of the air conditioner and turn "OFF" the power breaker.</p> <p>2) Remove the top panel(7 screws).</p> <p>3) Remove the screws of front panel(9 screws)</p> <p>4) Remove the screws of the right side panel(10 screws)</p>	 <p>4 screws of top panel</p> <p>3 screws of big handle</p> <p>9 screws of front panel</p> 
2	Fan ass'y	How to remove the fan ass'y.	

		<p>connector for fan motor from the electronic control board.</p> <p>4) Remove the four fixing screws of the fan motor.</p> <p>5) Then remove the fan motor.</p>	
3	Electrical parts	<p>How to remove the electrical parts.</p> <p>1) After finish work of item 1 and item 2, remove the connectors for the compressor and reactor.</p> <p>2) Pull out the two blue wires connected with the</p>	 

four way valve.

3) Pull out connectors of the compressor top temp. sensor, condenser coil temp. sensor(T3),outdoor ambient temp. sensor(T4) and discharge temp. sensor(T5).

4) disconnect the electronic expansion valve wire

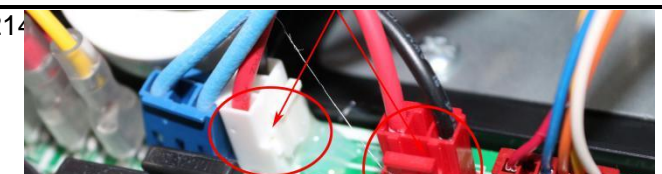
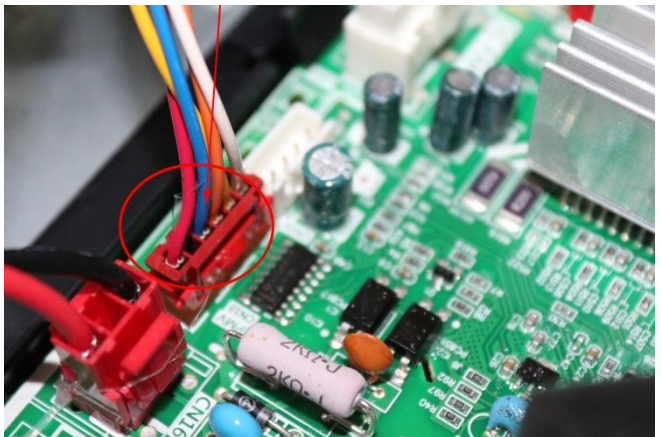
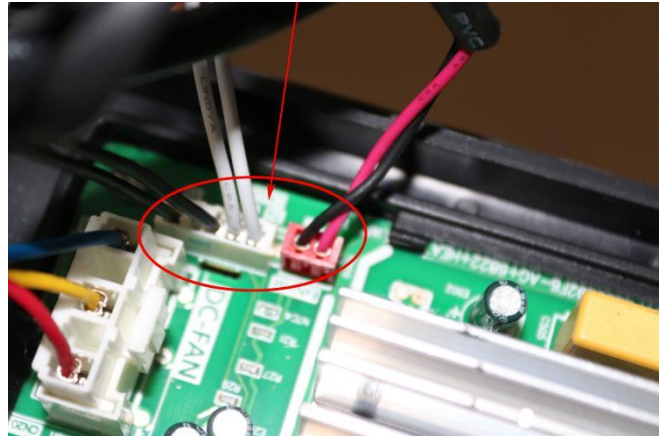

5) remove the compressor Crankcase electric heater



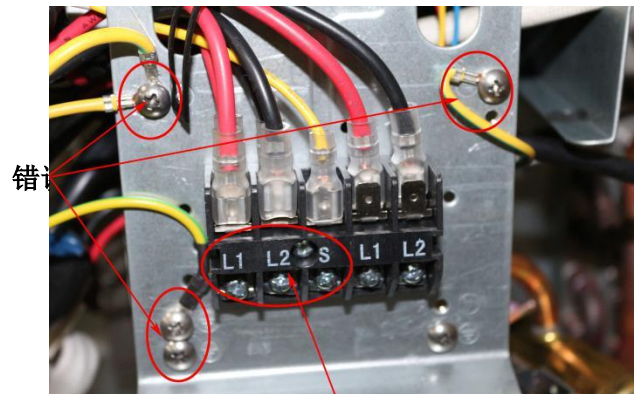

- 6) Remove the grounding screw.
- 7) Remove the power supply wires(old label, L1,L2,S; new label 1,2,3).
- 8) Then remove the electronic control box.

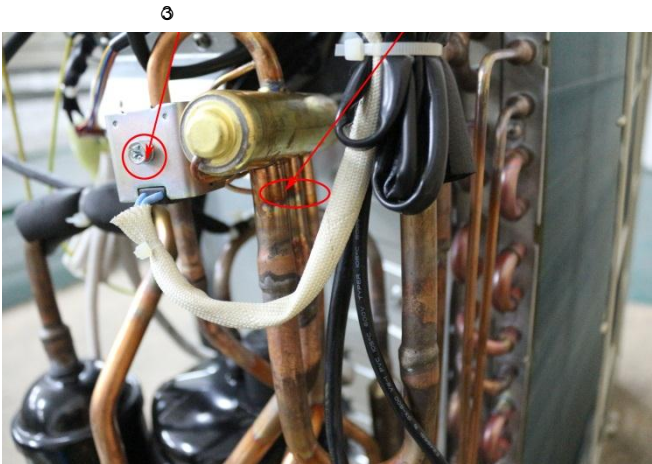

⑦

4	Four-way valve	<p>How to remove the four-way valve.</p> <ol style="list-style-type: none"> 1) Perform work of item1,2,3. 2) Recover refrigerant from the refrigerant circuit. 3) Remove the screw of the coil and then remove the coil. 4) Detach the welded parts of four-way valve and pipe. 5) Then the four-way valve ass'y can be removed 	<p>The picture of four-way valve may be different from the one on your side.</p> 
5	Compressor	<p>How to remove the compressor.</p> <ol style="list-style-type: none"> 1) After perform work of item1,2,3. 2) Remove the discharge pipe and suction pipe with a burner. 3) Remove the hex nuts and washers fixing the compressor on bottom plate. 4) Lift the compressor from the base pan assembly. 	

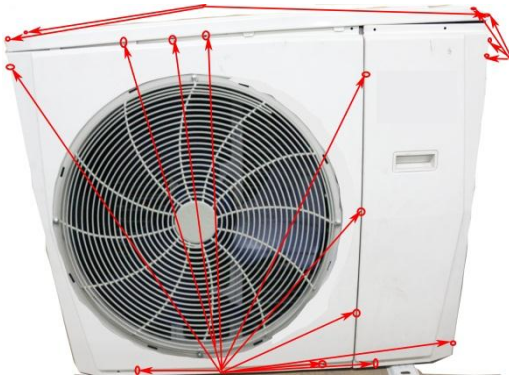
➤ MOD01-23HFN1-MT0W

No.	Part name	Procedures	Remarks
	Panel plate	<p>How to remove the panel plate.</p> <p>1) Stop operation of the air conditioner and turn "OFF" the power breaker.</p> <p>2) Remove the big handle first, then remove the top panel(7screws)</p> <p>3) Remove the screws of the front panel(11 screws)</p> <p>4) Remove the screws of the right side plate and remove the right side plate.(12 screws)</p>	<p>3 screws of top panel</p>  <p>4 screws of big handle</p> <p>11 screws of front panel</p> 
2	Fan ass'y	<p>How to remove the fan ass'y.</p>	

1) After remove the panel plate following procedure 1, remove the hex nut fixing the fan and then remove the fan.

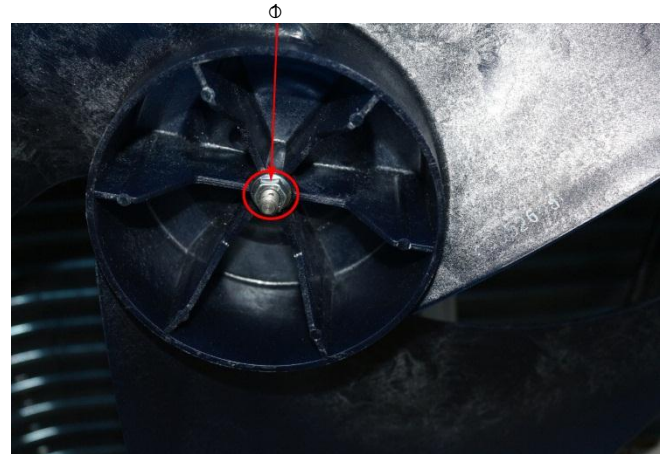

2) Unfix the hooks and screws, then open the electronic control box cover.

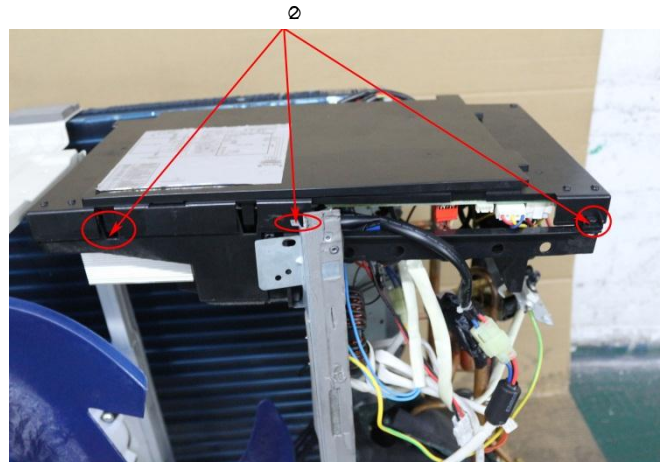

T3,T4,T5 sensor wire

Compressor wire

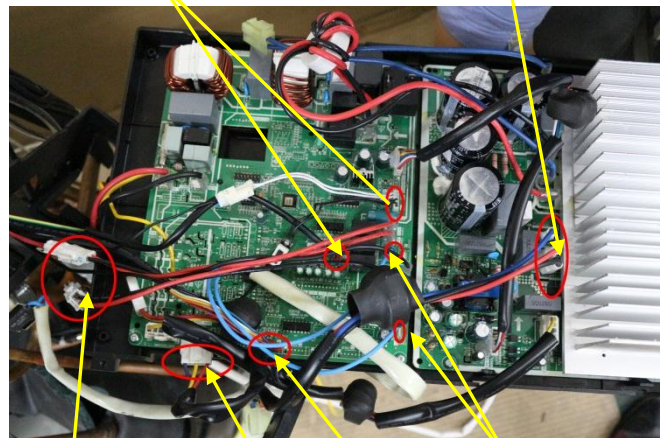

Electric pipe heater and Crankcase electric Heater wire

Motor wire

4 way valve

Electronic expansion Valve wire

3) Disconnect the connector for fan motor from the electronic control board.

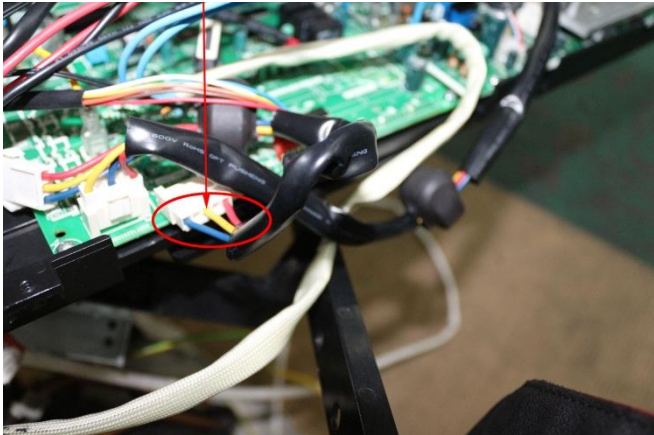
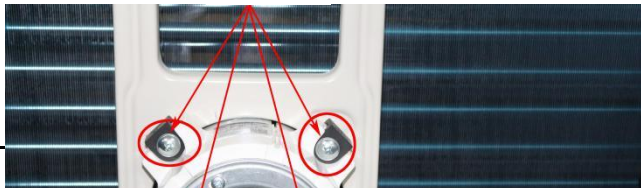
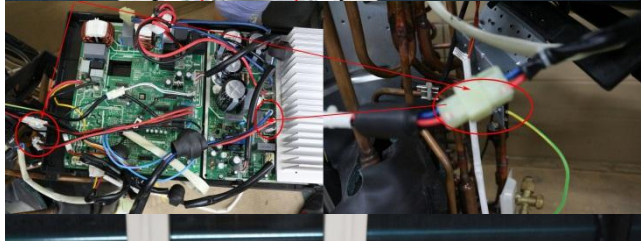
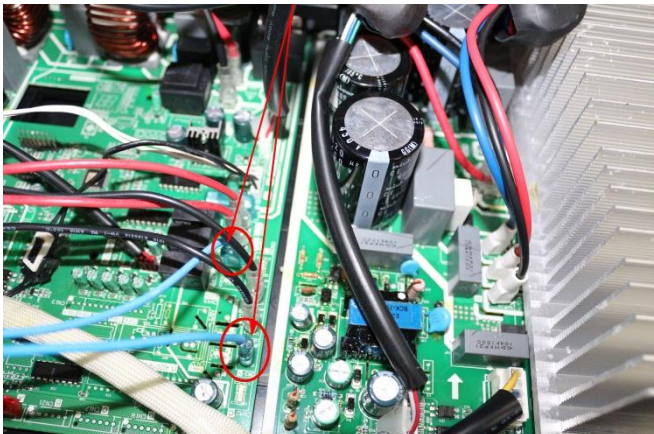
		<p>2) Remove the four fixing screws of the fan motor.</p> <p>3) Then remove the fan motor.</p>	 
3	Electrical parts	<p>How to remove the electrical parts.</p> <p>1) After finish work of item 1 and item 2, remove the three connectors for the compressor and the compressor crankcase heater and the electric heater.</p> <p>2) Pull out the two blue wires connected with the four way valve.</p> <p>3) Pull out connectors of the compressor top temp. sensor, condenser coil temp. sensor(T3),outdoor ambient temp. sensor(T4)</p>	 

and discharge temp.
sensor(T5).

4) Disconnect the
electronic expansion valve
wire from the control board

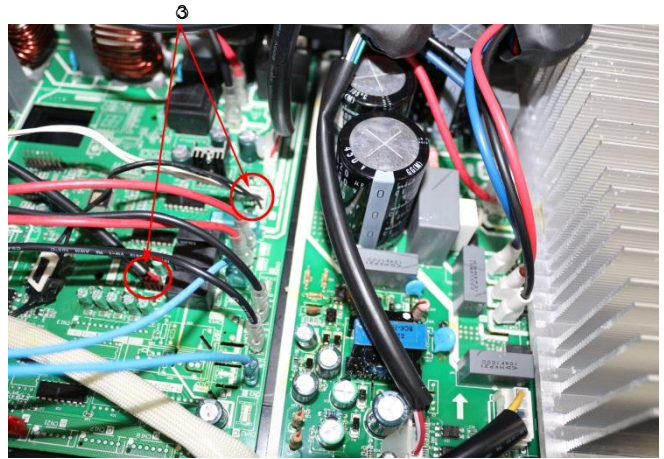

5) Remove the
grounding screw.

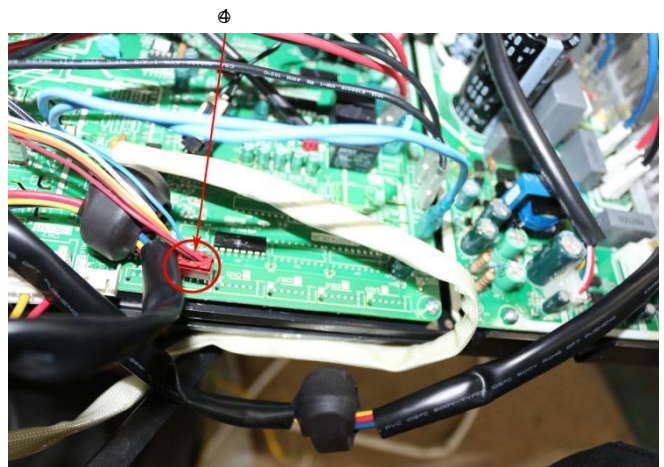

6) Remove the power
supply wires(old label,
L1,L2,S; old label 1,2,3).

7) Then remove the
electronic control box.

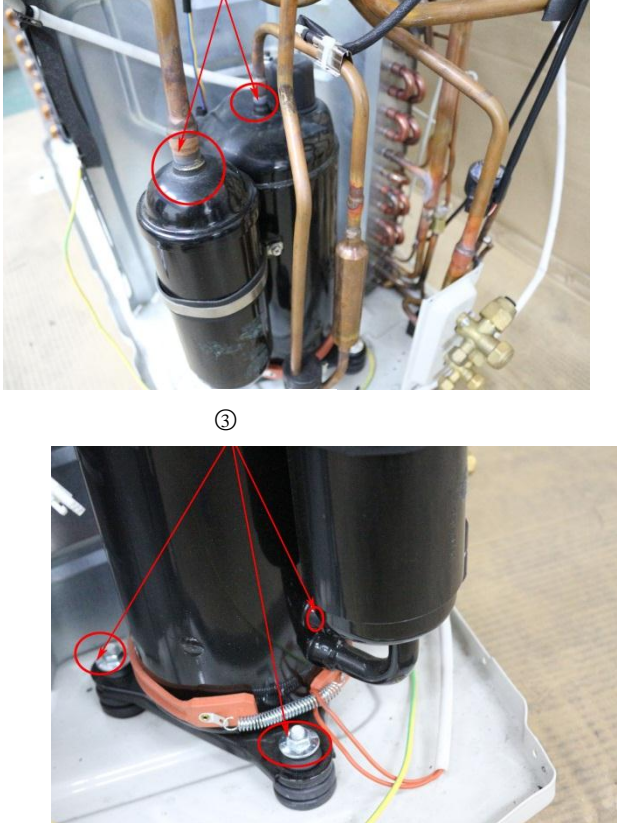

4	Four-way valve	<p>How to remove the four-way valve.</p> <ol style="list-style-type: none"> 1) Perform work of item1,2,3. 2) Recover refrigerant from the refrigerant circuit. 3) Remove the screw of the coil and then remove the coil. 4) Detach the welded parts of four-way valve and pipe. 5) Then the four-way valve ass'y can be removed 	<p>The picture of four-way valve may be different from the one on your side.</p> 
5	Compressor	<p>How to remove the compressor.</p> <ol style="list-style-type: none"> 1) After perform work of item1,2,3. 2) Remove the discharge pipe and suction pipe with a burner. 3) Remove the hex nuts and washers fixing the compressor on bottom plate. 4) Lift the compressor from the base pan assembly. 	

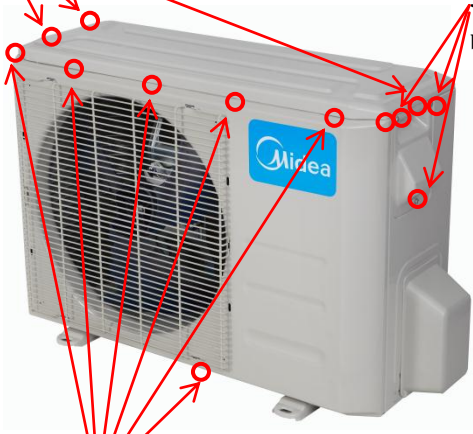
➤ **MOBA30-09HFN1-MT0W**

No.	Part name	Procedures	Remarks
1	Panel plate	<p>How to remove the panel plate.</p> <p>1) Stop operation of the air conditioner and turn "OFF" the power breaker.</p> <p>2) Remove the big handle first, then remove the top cover (3 screws)</p> <p>3) Remove the screws of front panel(7 screws)</p> <p>(4) Remove the screws of the right side panel(11 screws)</p>	<p>Screws of top panel (3 screws, 1 screw is under the big handle)</p>  <p>3 screw of big handle</p> <p>Screws of front panel(7 screws)</p> 
2	Fan ass'y	<p>How to remove the fan ass'y.</p> <p>1) After remove the</p>	

panel plate following procedure 1.

2) Remove the nut fixing the fan, and remove the fan.



3) After remove the top cover .Unfix the hooks and then open the electronic control box cover.

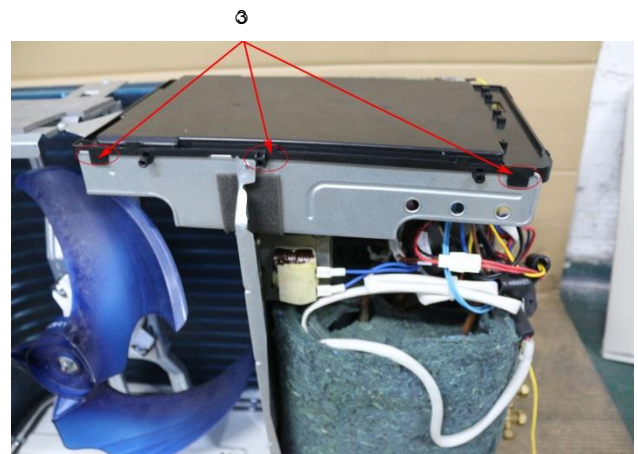

4) Disconnect the connector for fan motor from the electronic control board.

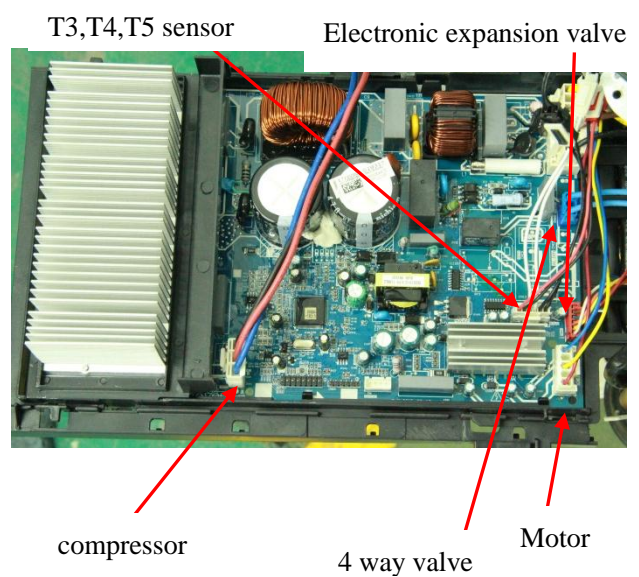

5) Remove the four fixing screws of the fan motor, then remove the motor.

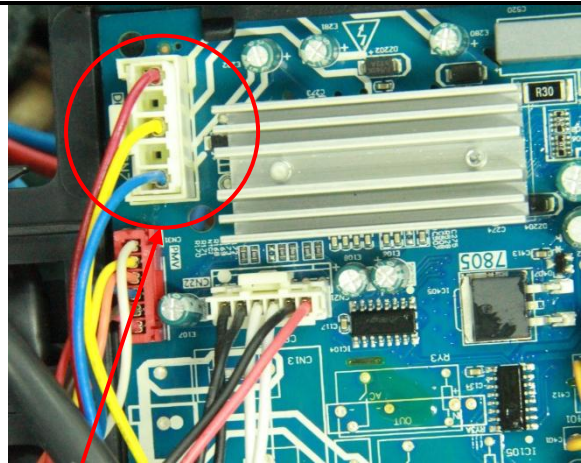

④

5

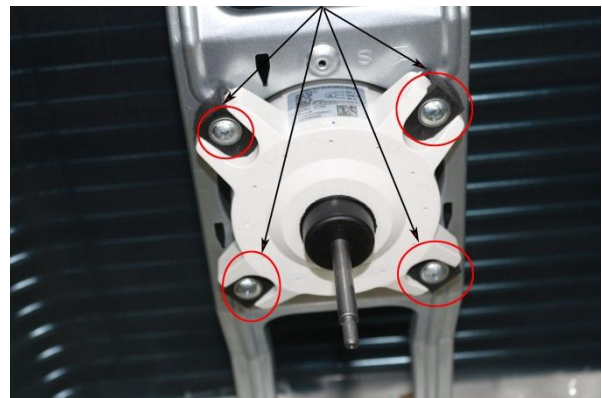

<p>3</p>	<p>Electrical parts</p>	<p>How to remove the electrical parts.</p> <p>5) After finish work of item 1 and item 2, remove the connector for the compressor .</p> <p>6) Pull out the two blue wires connected with the four way valve.</p> <p>3) Pull out connectors of the condenser coil temp. sensor(T3),outdoor ambient temp. sensor(T4) and discharge temp. sensor(T5).</p> <p>4) Disconnect the</p>	
----------	-------------------------	--	--

electronic expansion valve
wire from the control board

④

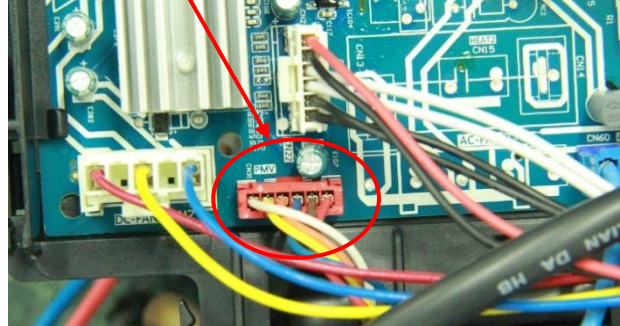

5) Remove the ground
wires .

6) Remove the
wires(1,2,3).

7) Then remove the
electronic control box.

5

6

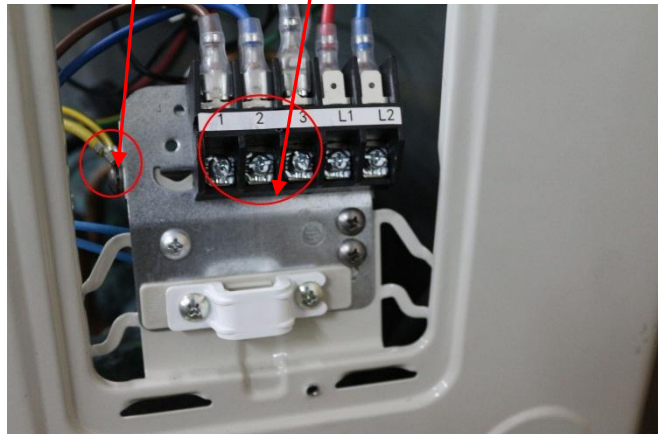

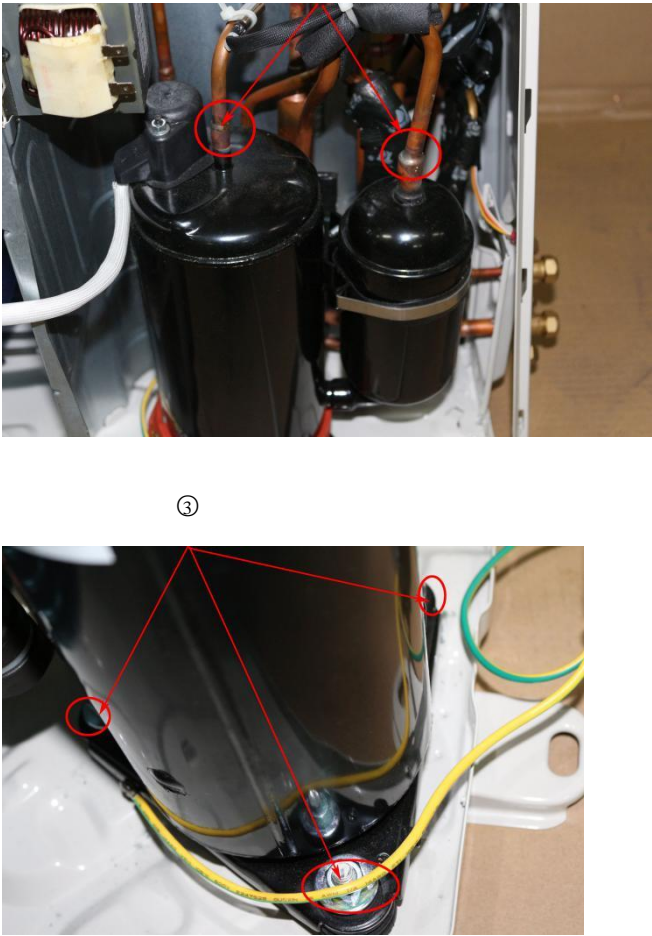
4	Four-way valve	<p>How to remove the four-way valve.</p> <ol style="list-style-type: none"> 1) Perform work of item 1,3. 2) Recover refrigerant from the refrigerant circuit. 3) Remove the screw of the coil and then remove the coil. 4) Detach the welded parts of four-way valve and pipe. 5) Then the four-way valve ass'y can be removed 	<p>The picture of four-way valve may be different from the one on your side. ④</p> 
5	Compressor	<p>How to remove the compressor.</p> <ol style="list-style-type: none"> 6) After perform work of item 1,3. Recover refrigerant from the refrigerant circuit. 7) Remove the discharge pipe and suction pipe with a burner. 8) Remove the hex nuts and washers fixing the compressor on bottom plate. 9) Lift the compressor from the base pan assembly. 	

ass'y.

1) After remove the panel plate following procedure 1, remove the hex nut fixing the fan and then remove the fan.

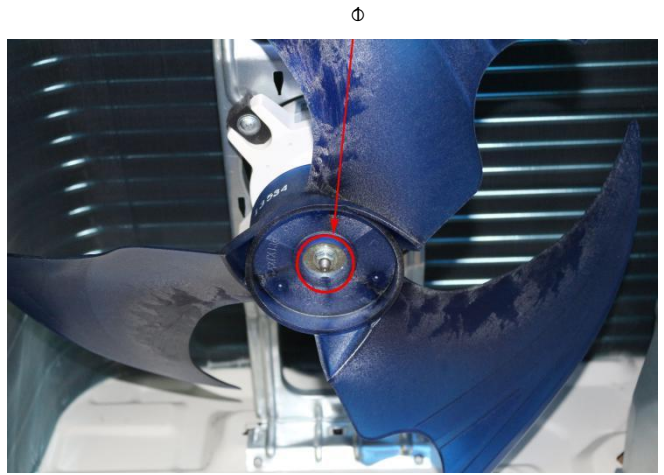

2) Unfix the hooks and then open the electronic control box cover.

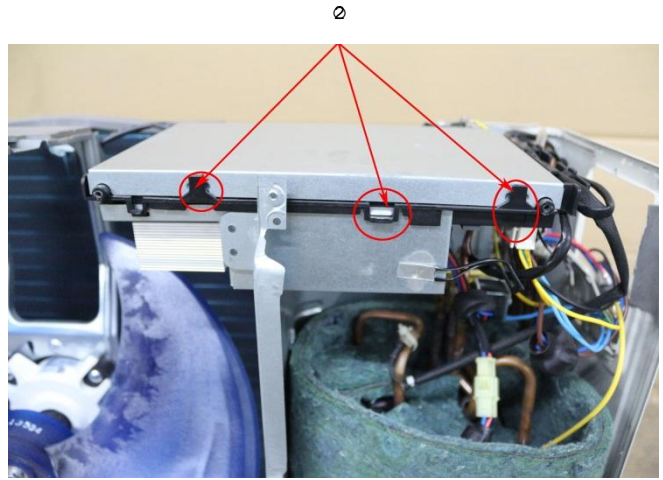

compressor

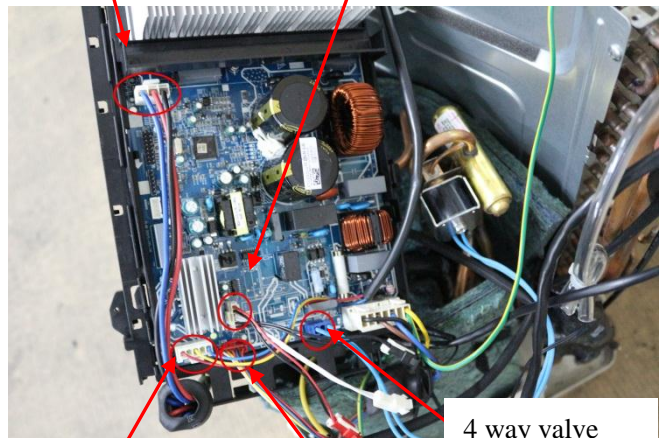

T3,T4,T5 sensor



Motor

Electronic expansion valve

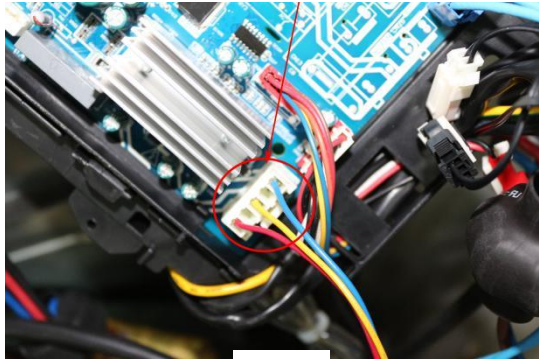
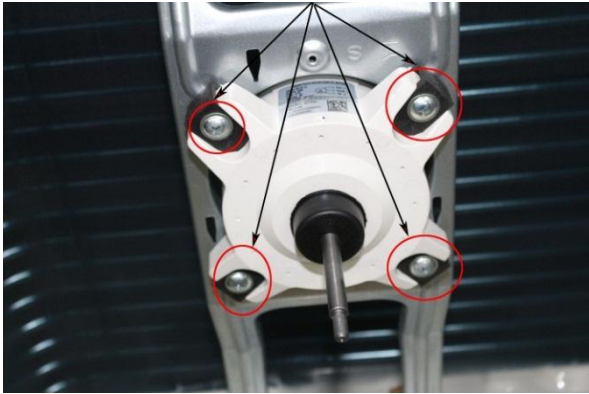
4 way valve

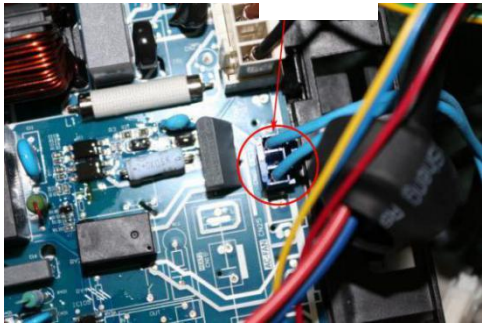
		<p>3) Disconnect the connector for fan motor from the electronic control board.</p> <p>4) Remove the four fixing screws of the fan motor. Then remove the fan motor.</p>	 
<p>3</p>	<p>Electrical parts</p>	<p>How to remove the electrical parts.</p> <p>1) After finish work of item 1 and item 2, remove the connectors for the compressor.</p> <p>2) Pull out the two blue wires connected with the four way valve.</p>	 

3) Pull out connectors of the condenser coil temp. sensor(T3), outdoor ambient temp. sensor(T4) and discharge temp. sensor(T5).

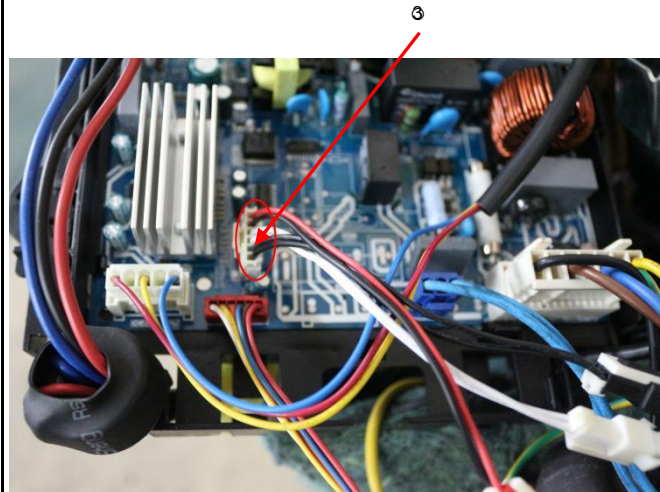

4) disconnect the electronic expansion valve wire

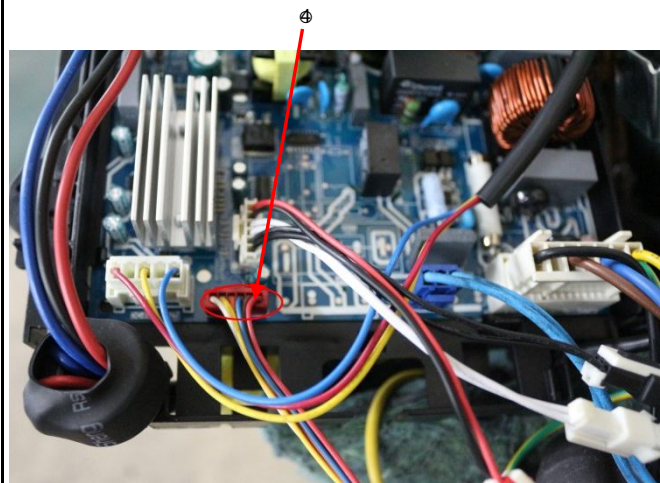

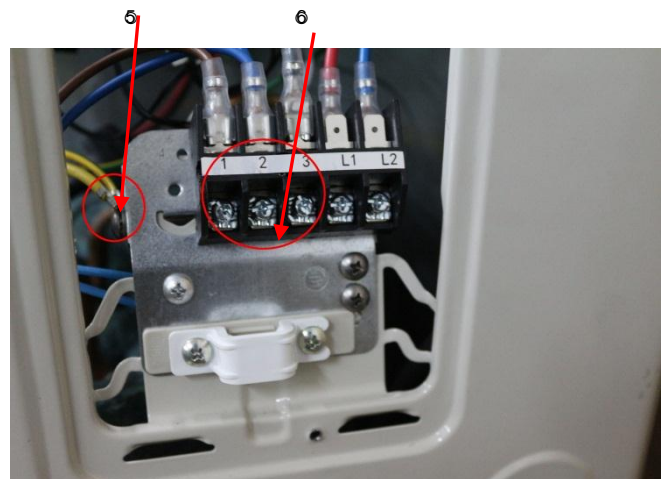

5) Remove the grounding screw.

6) Remove the Wires (1,2,3). Then remove the electronic control box.

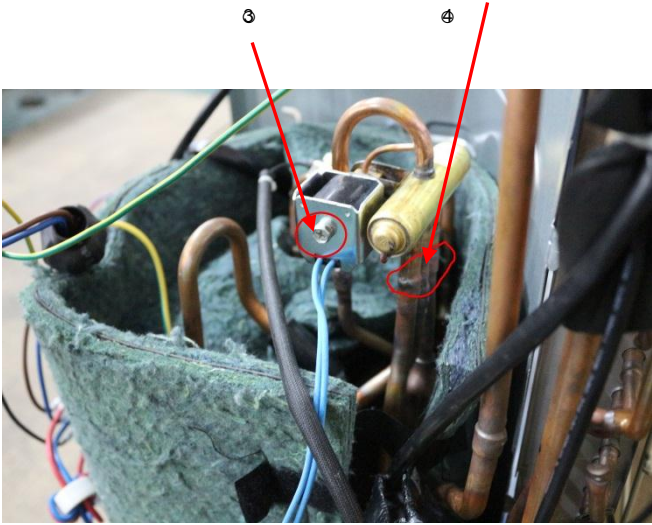
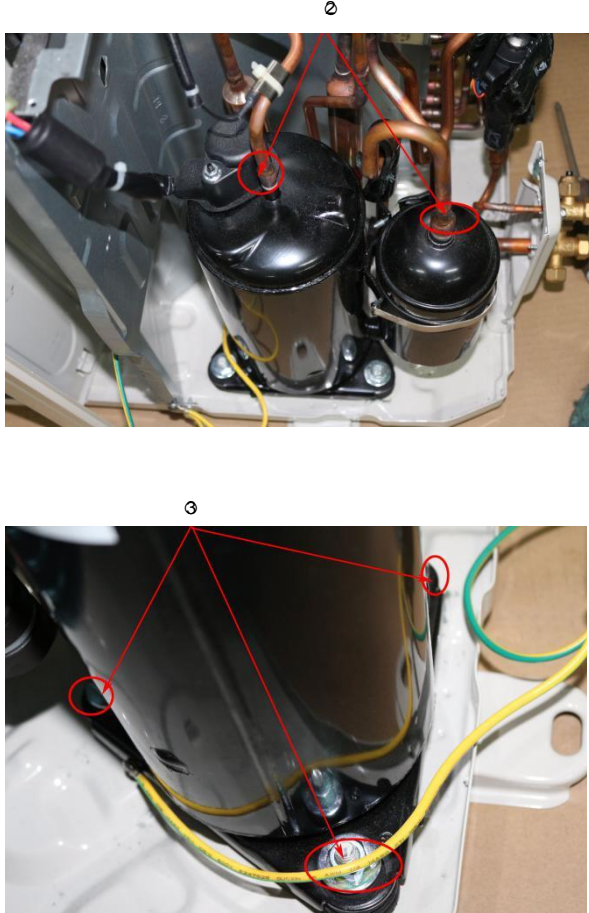

4	Four-way valve	<p>How to remove the four-way valve.</p> <ol style="list-style-type: none"> 1) Perform work of item 1,3. 2) Recover refrigerant from the refrigerant circuit. 3) Remove the screw of the coil and then remove the coil. 4) Detach the welded parts of four-way valve and pipe. 10) Then the four-way valve ass'y can be removed 	<p>The picture of four-way valve may be different from the one on your side.</p> 
5	Compressor	<p>How to remove the compressor.</p> <ol style="list-style-type: none"> 1) After perform work of item 1,3. Recover refrigerant from the refrigerant circuit. 2) Remove the discharge pipe and suction pipe with a burner. 3) Remove the hex nuts and washers fixing the compressor on bottom plate. 4) Lift the compressor from the base pan assembly. 	

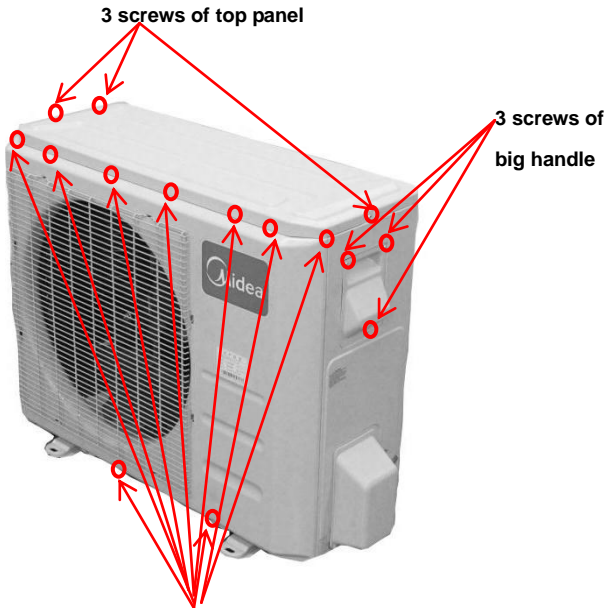
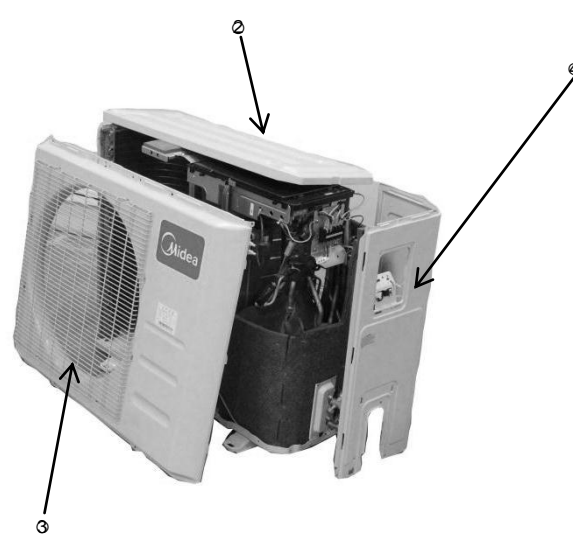
➤ MOCA30-18HFN1-MT0W, MOCA31-18HFN1-MT0W

No.	Part name	Procedures	Remarks
	Panel plate	<p>How to remove the panel plate.</p> <p>1) Stop operation of the air conditioner and turn "OFF" the power breaker.</p> <p>2) Remove the top panel(3 screws).</p> <p>3) Remove the screws of front panel(9 screws)</p> <p>4) Remove the screws of the right side panel(8 screws)</p>	 <p>3 screws of top panel</p> <p>3 screws of big handle</p> <p>9 screws of front panel</p>  <p>2</p> <p>3</p> <p>4</p>
2	Fan ass'y	How to remove the fan ass'y.	 <p>φ</p>

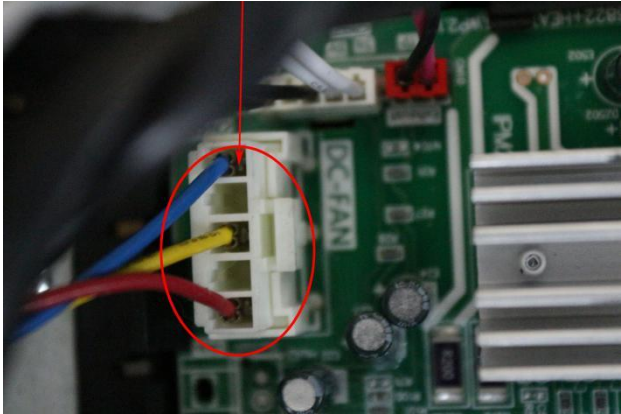
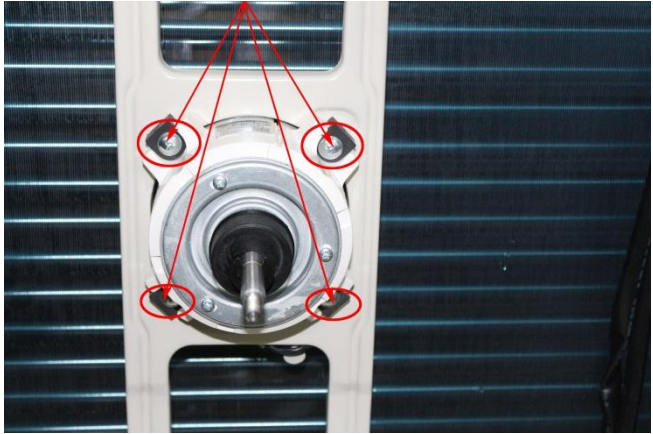
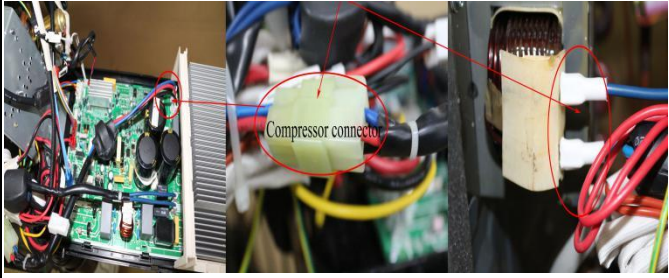
		<p>board.</p> <p>4) Remove the four fixing screws of the fan motor. Then remove the fan motor.</p>	<p style="text-align: center;">③</p>  <p style="text-align: center;">④</p> 
<p>3</p>	<p>Electrical parts</p>	<p>How to remove the electrical parts.</p> <p>1) After finish work of item 1 and item 2, remove the connectors for the compressor and reactor.</p> <p>2) Pull out the two blue wires connected with the four way valve.</p>	<p style="text-align: center;">①</p>  <p style="text-align: center;">②</p>

3) Pull out connectors of the condenser coil temp. sensor(T3), outdoor ambient temp. sensor(T4) and discharge temp. sensor(T5).

4) disconnect the electronic expansion valve wire

6) remove the electric heaters.

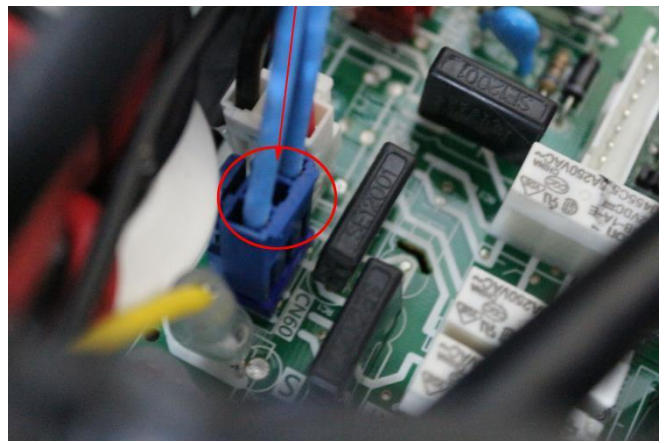

3

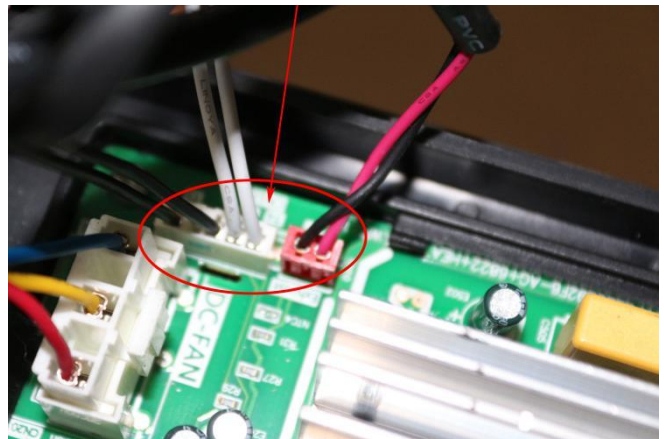

4

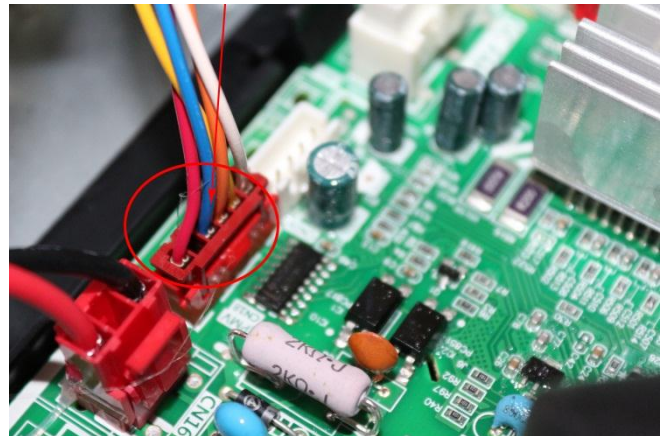

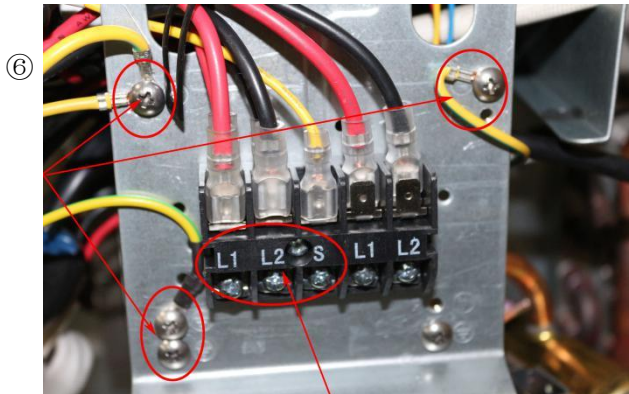
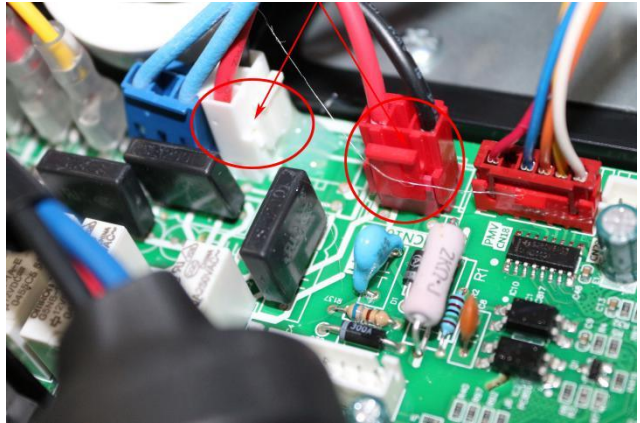

5

6) Remove the grounding screw.
7) Remove the Wires (1,2,3 or L1,L2,S).Then remove the electronic control box.

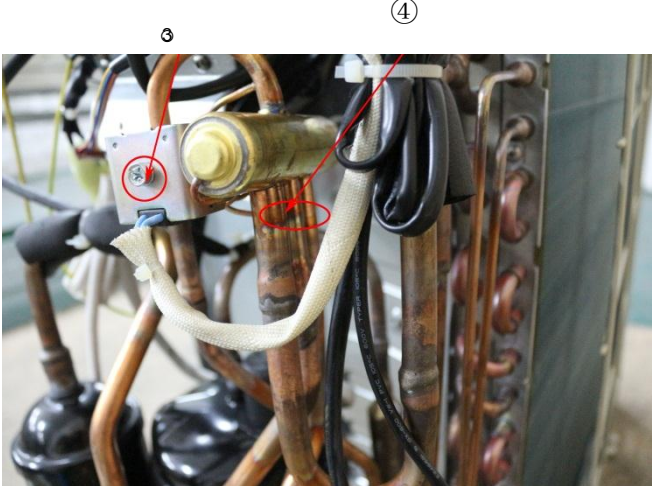

⑦

4	Four-way valve	<p>How to remove the four-way valve.</p> <ol style="list-style-type: none"> 1) Perform work of item1,3. 2) Recover refrigerant from the refrigerant circuit. 3) Remove the screw of the coil and then remove the coil. 4) Detach the welded parts of four-way valve and pipe. 11) Then the four-way valve ass'y can be removed 	<p>The picture of four-way valve may be different from the one on your side.</p> 
5	Compressor	<p>How to remove the compressor.</p> <ol style="list-style-type: none"> 1) After perform work of item1,3. Recover refrigerant from the refrigerant circuit 2) Remove the discharge pipe and suction pipe with a burner. 3) Remove the hex nuts and washers fixing the compressor on bottom plate. 4) Lift the compressor from the base pan assembly. 	

➤ MOD30-24HFN1-MT0W, MOD31-24HFN1-MT0W, MOD30U-36HFN1-M

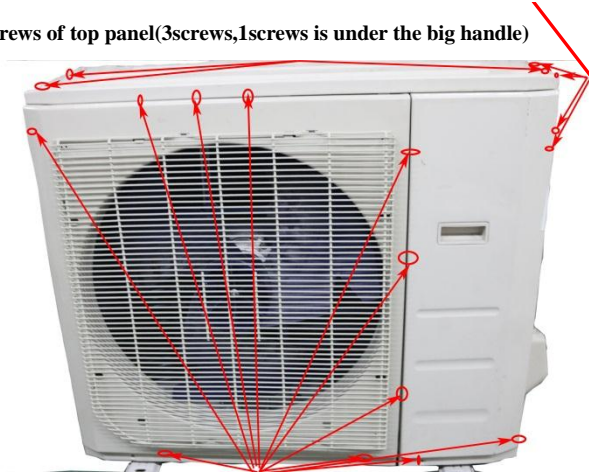
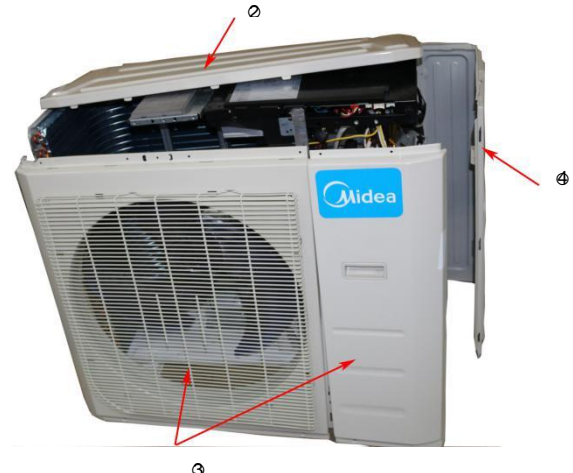
No.	Part name	Procedures	Remarks
1	Panel plate	<p>How to remove the panel plate.</p> <p>1) Stop operation of the air conditioner and turn "OFF" the power breaker.</p> <p>2) Remove the big handle first, then remove the top cover (7 screws)</p> <p>3) Remove the screws of front panel (11 screws)</p> <p>(4) Remove the screws of the right side panel (13 screws)</p>	<p>4 screws of big handle</p> <p>Screws of top panel (3 screws, 1 screw is under the big handle)</p>  <p>Screws of front panel (11 screws)</p> 

2	Fan ass'y	<p>How to remove the fan ass'y.</p> <p>1) After remove the panel plate following procedure 1</p> <p>2) Remove the nut fixing the fan, and remove the fan.</p> <p>3) Unfix the hooks and remove the screws, then open the electronic control box cover.</p>
---	-----------	--

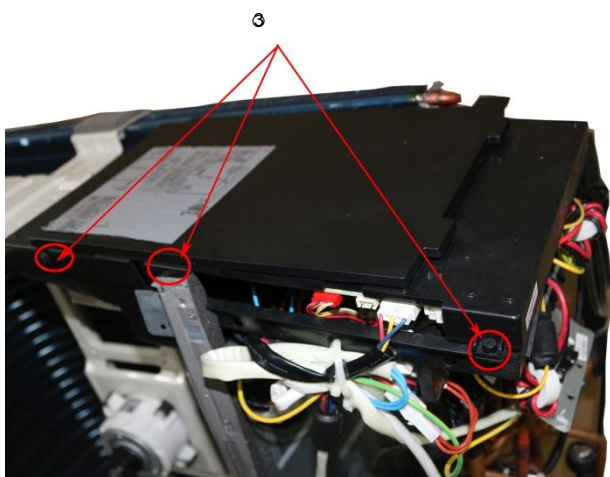
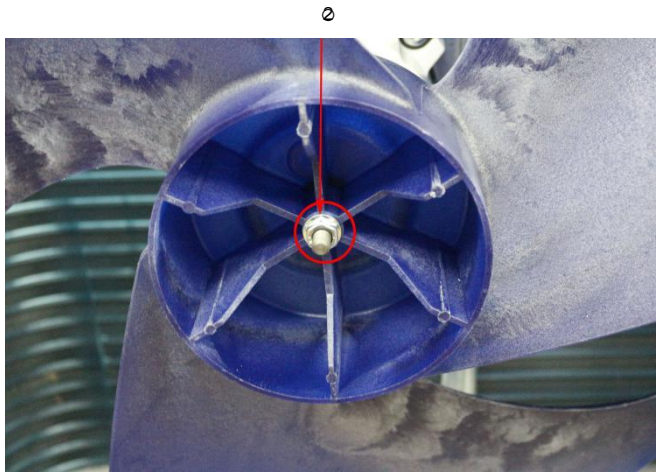
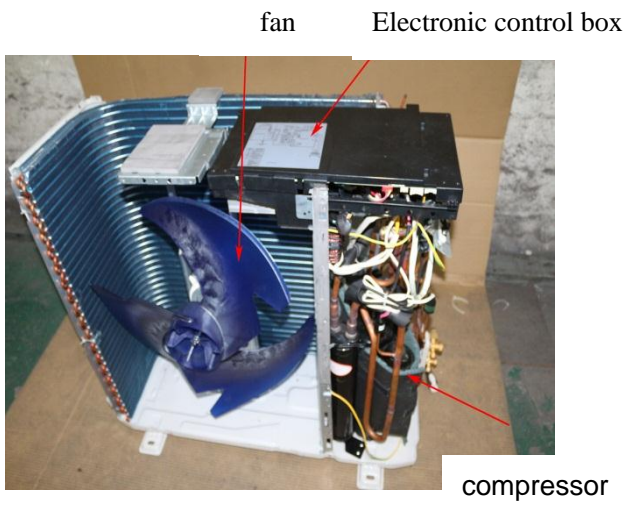

4) Disconnect the connector for fan motor from the electronic control board.

5) Remove the four fixing screws of the fan motor, then remove the motor.

T3,T4,T5,sensor Pressure switch Compressor wire

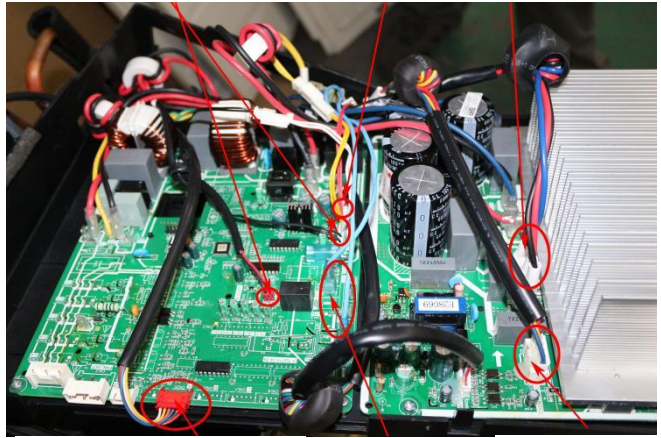

Electronic expansion 4 way valve Motor wire

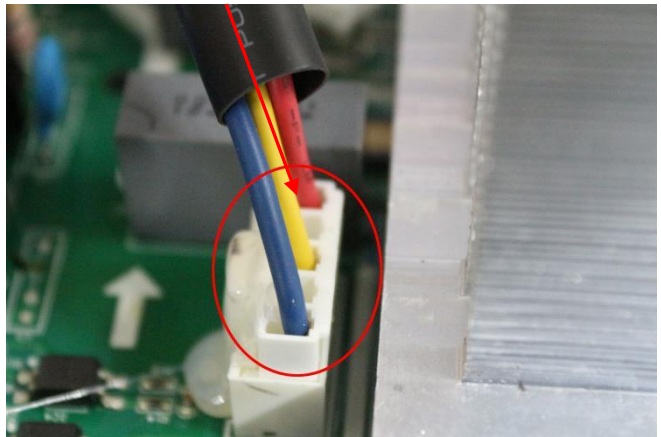

⑤

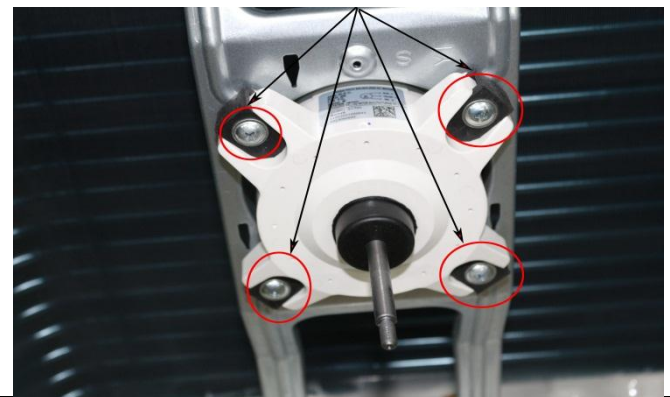

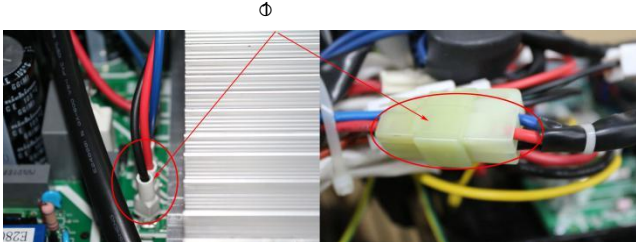
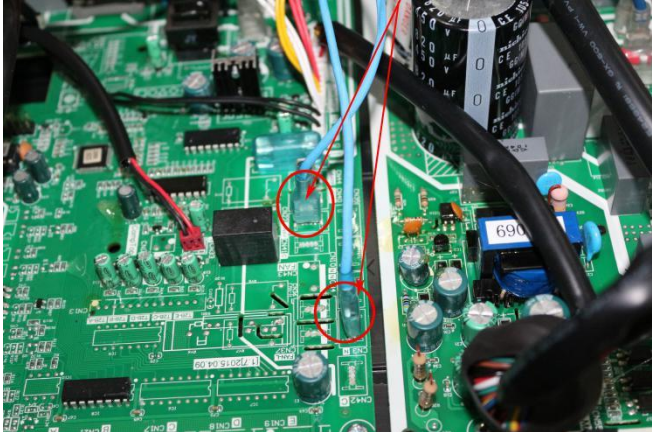
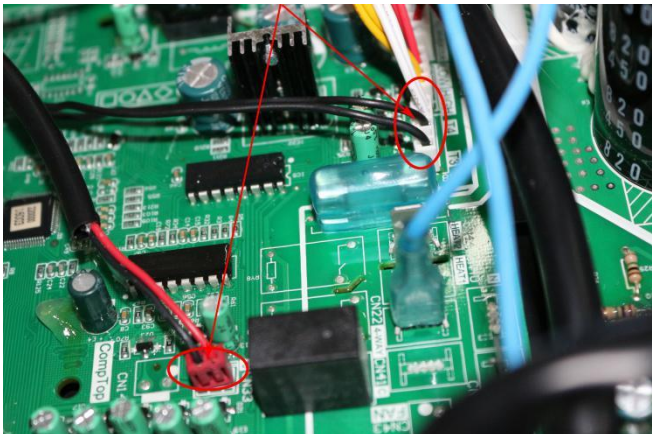
3	Electrical parts	<p>How to remove the electrical parts.</p> <p>1) After finish work of item 1 and item 2, remove the connector for the compressor</p> <p>2) Pull out the two blue wires connected with the four way valve.</p> <p>3) Pull out connectors of the, condenser coil temp. sensor(T3),outdoor ambient temp. sensor(T4) and discharge temp. sensor(T5).</p> <p>4)Disconnect the pressure switch connector.</p>	  
---	------------------	---	---

5) Disconnect the electronic expansion valve wire from the control board

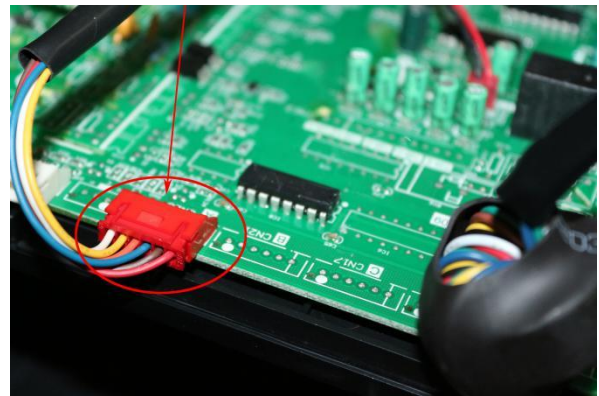
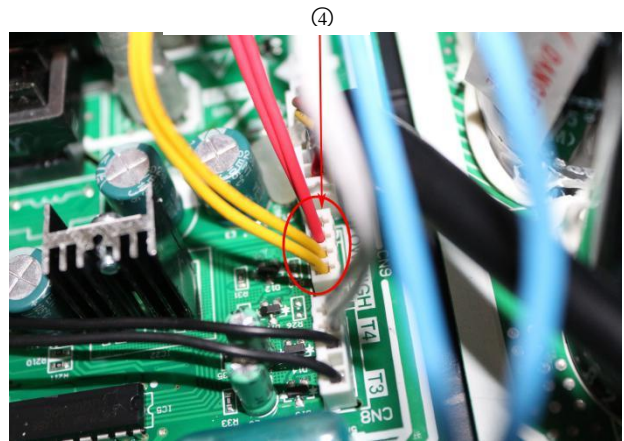

6) Remove the ground wires .

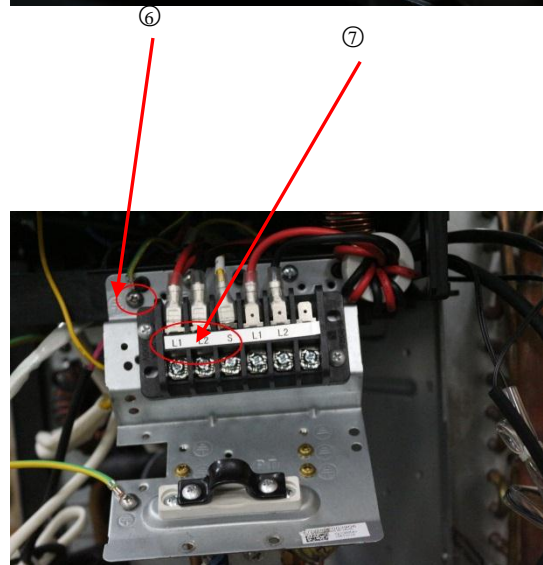

7) Remove the wires(1,2,3 or L1,L2,S).
Then remove the electronic control box.

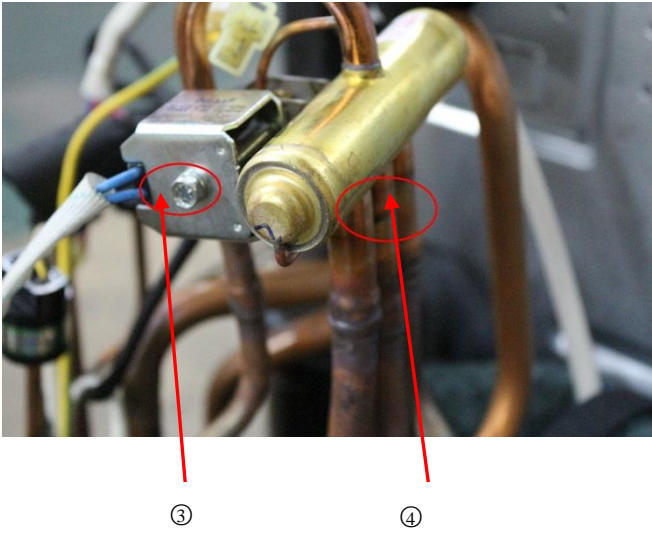
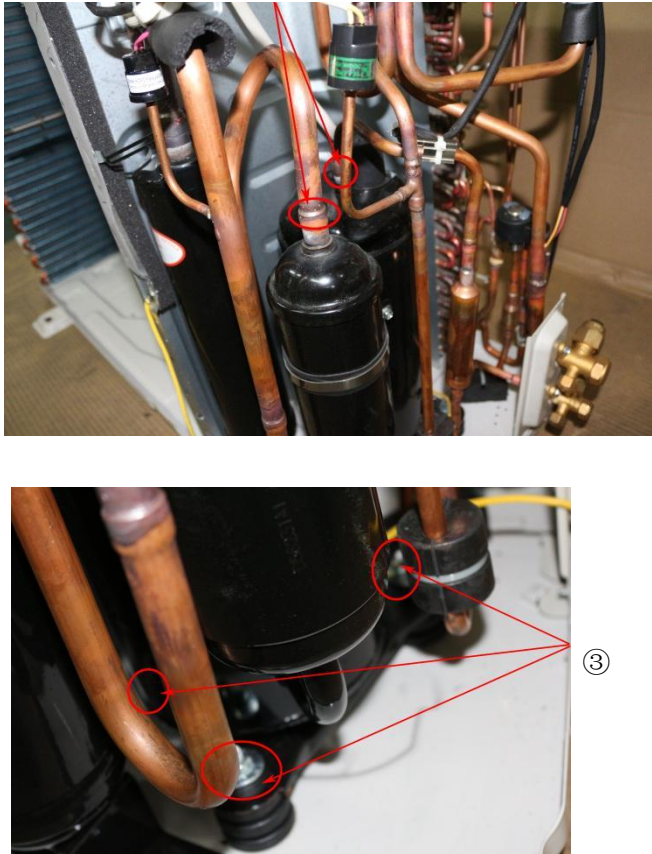

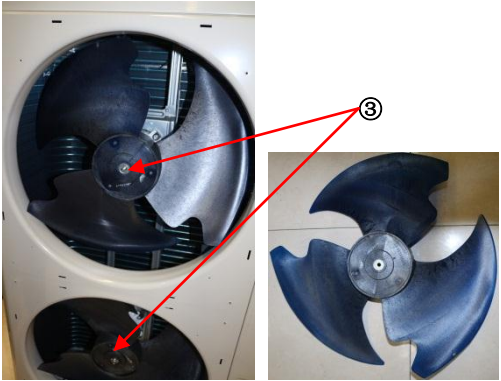
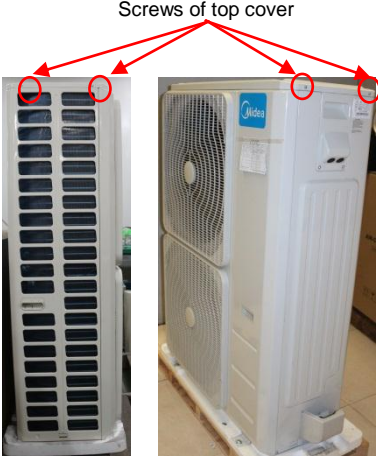

4	Four-way valve	<p>How to remove the four-way valve.</p> <ol style="list-style-type: none"> 1) Perform work of item 1,3. 2) Recover refrigerant from the refrigerant circuit. 3) Remove the screw of the coil and then remove the coil. 4) Detach the welded parts of four-way valve and pipe. 5) Then the four-way valve ass'y can be removed 	<p>The picture of four-way valve may be different from the one on your side.</p> 
5	Compressor	<p>How to remove the compressor.</p> <ol style="list-style-type: none"> 1) After perform work of item1,3. Recover refrigerant from the refrigerant circuit. 2) Remove the discharge pipe and suction pipe with a burner. 3) Remove the hex nuts and washers fixing the compressor on bottom plate. 4) Lift the compressor from the base pan assembly. 	

➤ MOE30U-48HFN1-M, MOE30U-60HFN1-M

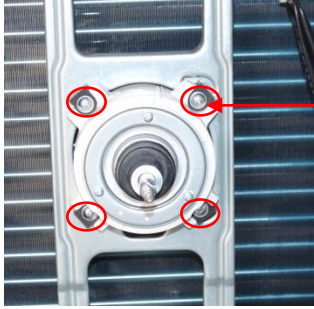
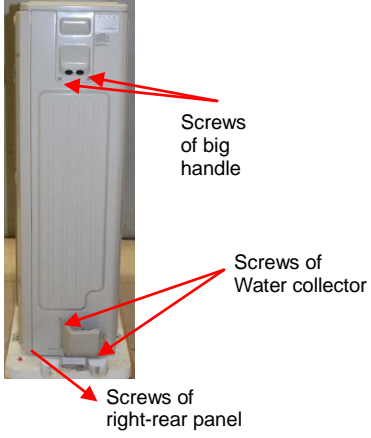
No.	Part name	Procedures	Remarks
1	Fan ass'y	<p>How to remove the fan ass'y.</p> <p>1) Stop operation of the air conditioner and turn "OFF" the power breaker.</p> <p>2) Remove the screws of air outlet grille(8 screws)</p> <p>3) Remove the hex nut fixing the fan.</p> <p>4) Remove the fan.</p> <p>5) Remove the screws of top cover, and remove the top cover. (4 screws)</p> <p>6) Remove the screws of right front side panel, and remove the right front side panel (1</p>	  

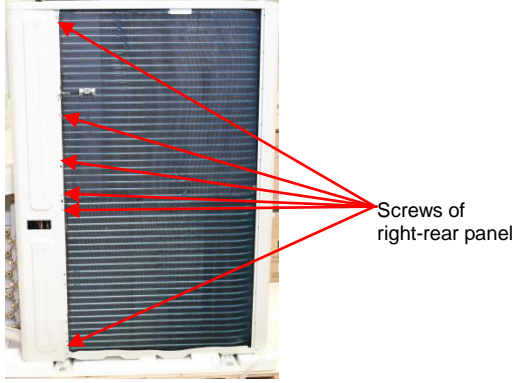
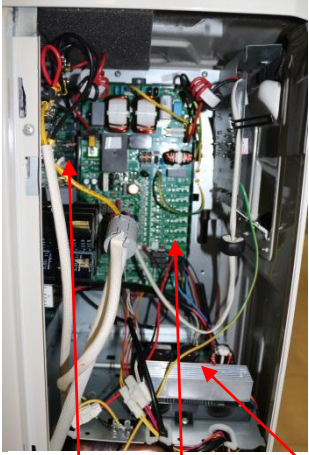
		<p>screw)</p> <p>7) Disconnect the fan motor connectors FAN1(3p,white) and FAN2(3p,white) from DC motor driver board.</p> <p>8) Remove the fan motor after unfastening fixing screws.</p>	  
2	Panel plate	<p>How to remove the panel plate.</p> <p>1) Remove big handle.(2 screws) and water collector(2 screws)</p> <p>2) Remove two screws of terminal board and seven screws of right-rear panel, and remove the right-rear panel.</p>	 <p>Screws of big handle</p> <p>Screws of Water collector</p> <p>Screws of right-rear panel</p>

			
3	Electrical parts	<p>How to remove the electrical parts.</p> <p>1) Perform work of item 1 step 5~6 and item 2.</p> <p>2) Disconnect the fan motor connector(5p,white) from the IPM board.</p> <p>3) Disconnect following 8 pieces of connection wires and connectors between IPM and other parts.</p>	 <p>IPM board PCB board DC Fan Driver board</p>  <p>②</p>

CN2(yellow)

CN1(red)

CN6(black)

CN3(yellow)

U、V、W(black)

CN9(10p,white)

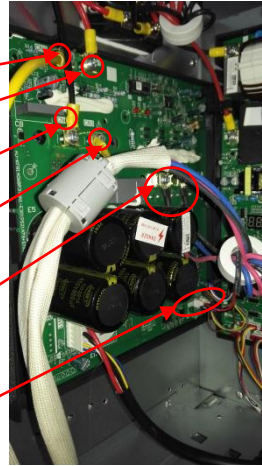

4) Remove the screws fixing the IPM board and remove the IPM board.

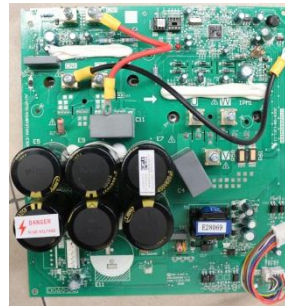

5) Disconnect the connectors and wires connected from PCB and other parts.

Connectors:

CN8: Discharge temperature sensor (2p,white)

CN12: Heatsink temperature sensor(2p,red)

CN9:T3/T4 temperature sensor (2p/2p,white)

CN15: Electronic expansion valve (6p,red)

CN10: High and low pressure switch (2p/2p, white)

Wires:

CN17/CN18: 4-way valve (blue-blue)

CN19/CN20: connected to crankcase heating cable. (black-red)

CN24/CN25: Electric heater of chassis (orange-orange)

CN1:L-IN (red or white)

CN3:N-IN (black)

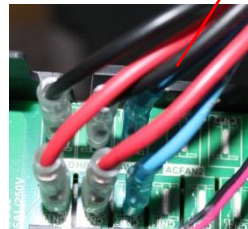
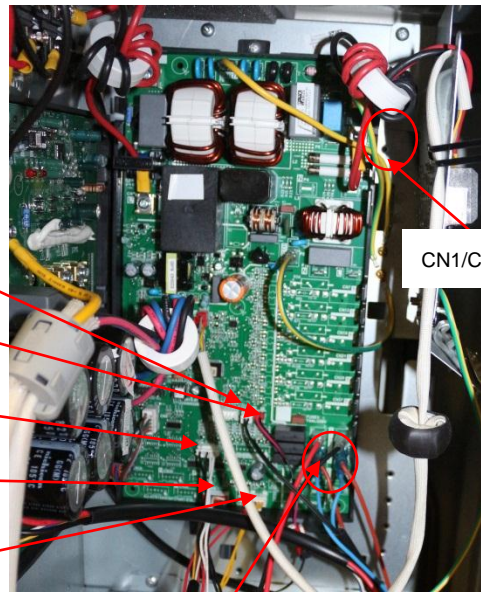



CN17/CN18

CN19/CN20

CN24/CN25

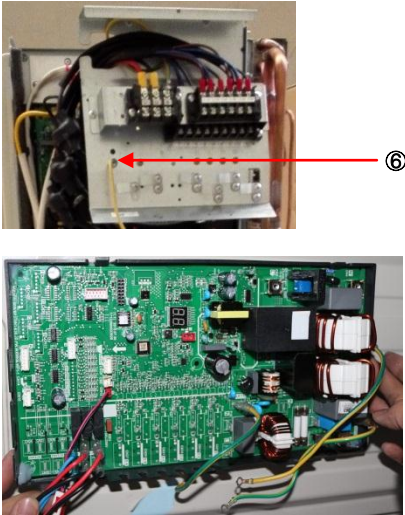
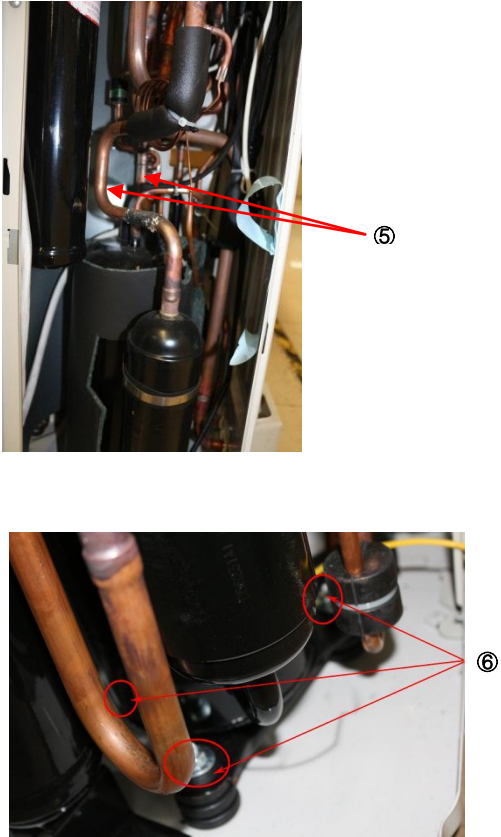
6) Disconnect the grounding

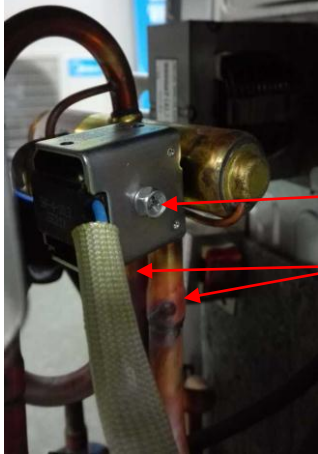
		<p>wire (yellow-green) after removing the big handle.</p> <p>7) Remove the PCB board.</p>	
4	Compressor	<p>How to remove the compressor.</p> <ol style="list-style-type: none"> 1) Perform work of item 1 step 5~6 and item 2.. 2) Extract refrigerant gas. 3) Remove the sound insulation material and crankcase heating cable. 4) Remove terminal cover of compressor, and disconnect wires of crankcase electric heater and compressor from the terminal. 5) Remove the discharge pipe and suction pipe with a burner. 6) Remove the hex nuts and washers fixing the compressor to bottom plate. 7) Lift the compressor. 	

5	The 4-way valve	<p>How to remove the 4-way valve</p> <ol style="list-style-type: none"> 1) Perform work of item 1 step 5~6 and item 2.. 2) Extract refrigerant gas. 3) Remove the electrical parts from item 3. 4) Remove fixing screw of the coil, and remove the coil. 5) Detach the welded parts of 4-way valve and pipe. 	 <p>Coil</p> <p>Welded parts</p>
6	The expansion valve	<p>How to remove the expansion valve</p> <ol style="list-style-type: none"> 1) Perform work of item 1,2. 2) Remove the electrical parts from item 3.. 3) Remove the coil. 4) Detach the welded parts of expansion valves and pipes. 	 <p>Expansion valves</p>