

Service Manual

COMPACT SERIES

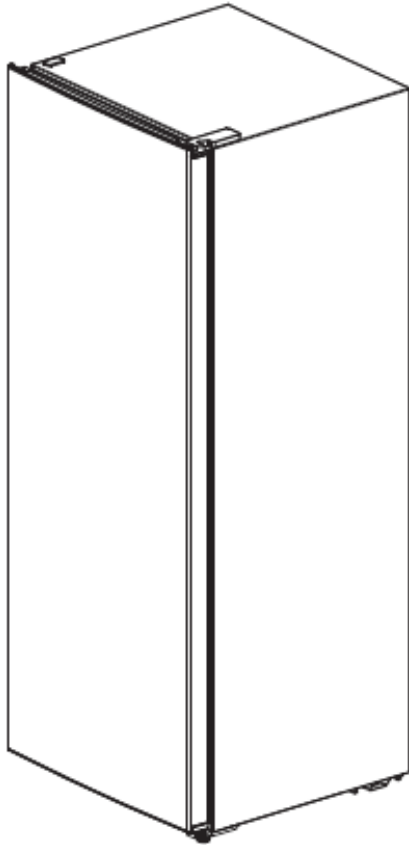

Applicable Models	Model Code
UR-BD186-DQ	22031010001841

Prepared by	R&D:Liu Ya
Reviewed by	QA:Gao Hongbing SVC: Zhang Kun
Approved by	R&D:Liu Chao

(The picture in this service manual is only for reference, and specific appearance and configuration are subject to the real product)



 **WARNING****Important Safety Notice**

There are special components used in this equipment which are important for safety. These parts are marked by  in the Schematic Diagrams, Circuit Board Diagrams, Exploded Views and Replacement Parts List. It is essential that these critical parts should be replaced with manufacturer's specified parts to prevent shock, fire or other hazards. Do not modify the original design without permission of manufacturer.

 **WARNING****Important Safety Notice**

The Maintenance Manual is only for the use of maintenance personnel with certain experience and background in electrical, electronic and mechanical field.

Any attempt to repair main devices may lead to personal injury and property loss.

Manufacturers or distributors are not responsible for the content of the Manual and interpretation thereof.

Midea Refrigerators

Technical Maintenance Manual

Copyright @2017

All rights reserved. Replication of all or part of the Manual in any forms shall not be allowed without written approval by the Overseas Sales Corporation of Midea Refrigerators.

Contents





1. SAFETY WARNING CODE	5
1.1 WARNING FOR OPERATION SAFETY	5
1.2 SAFETY INSTRUCTION FOR REFRIGERANT	7
2. DESCRIPTION FOR PRODUCT FEATURES	8
3. INSTALLATION AND COMMISSIONING	9
3.1 HANDLING.....	9
3.2 DOOR DISASSEMBLY AND ASSEMBLY	9
3.3 INSTALLATION LOCATION	9
3.4 LEVELING OF THE REFRIGERATOR	9
3.5 DOOR REVERSAL.....	10
3.6 INSTALLATION OF HANDLE	11
3.7 INSTALLATION OF DOOR LOCK.....	11
3.8 ADJUSTMENT TO LEVEL THE DOOR	11
3.9 ADJUSTMENT TO SHELVES	11
4. TERMS	12
4.1 DEFINITION OF MODEL (NONE)	12
4.2 LOCATION OF NAMEPLATE (NONE)	12
5. PRODUCT SPECIFICATION	13
5.1 TYPE SPECIFICATION(NONE)	13
5.2 ELECTRICAL PARAMETERS	13
5.3 INSIDE TEMPERATURE	14
5.4 DEFROSTING PARTS	14
5.5 CIRCUIT DIAGRAM	15
6. INTERNAL VIEW AND DIMENSION	16
6.1 MAIN PARTS AND THEIR NAMES.....	16
6.2 EXTERNAL DIMENSION	17
7. REFRIGERATING PIPING SYSTEM AND CIRCULATING ROUTE OF COOLING AIR	18
7.1 REFRIGERATING PIPING SYSTEM	18
7.2 CIRCULATING ROUTE OF COOLING AIR(NONE)	18
8. DISMANTLING OF PARTS	19
8.1 PARTS ON THE DOOR.....	19
8.2 PARTS INSIDE THE REFRIGERATOR	19
8.3 LIGHT SYSTEM.....	20
8.4 AIR DUCT COMPONENTS REFRIGERATING CHAMBER.....	20
8.5 AIR DUCT COMPONENTS IN FREEZING CHAMBER AND FAN MOTOR.....	20
8.6 EVAPORATOR AND TEMPERATURE SENSING SYSTEM	20

8.7 COMPRESSOR CASE	21
8.8 DISPLAY CONTROL BOARD	26
8.9 MAIN CONTROL BOARD	26
8.10 BAR COUNTER.....	26
8.11 WATER DISPENSER.....	26
8.12 ICE MAKER	26
9. FUNCTION AND OPERATION	27
9.1 OPERATION PANEL	27
9.2 TEMPERATURE CONTROL.....	27
9.3 GIVE AN ALARM (NONE)	27
9.4 FAILURE CODE AND SOLUTIONS (NONE).....	27
9.5 DEFROST FUNCTION.....	27
9.6 COMPRESSOR FAN CONTROL (NONE)	27
10. CIRCUIT DESCRIPTION	28
10.1 POWER SUPPLY(NONE).....	28
10.2 TEST CIRCUIT FOR DOOR SWITCH(NONE)	28
10.3 TEMPERATURE TEST CIRCUIT(NONE)	28
10.4 FREEZER CHAMBER FAN MOTOR CIRCUIT (NONE).....	28
10.5 REFRIGERATING CHAMBER FAN MOTOR CIRCUIT (NONE)	28
10.6 CONDENSATION FAN CIRCUIT (NONE)	28
10.7 FAN MOTOR CIRCUIT OF THE VENTILATION DOOR(NONE).....	28
10.8 RESISTANCE VALUE OF THE SENSOR (R/T) (NONE).....	28
11. TROUBLESHOOTING METHOD	29
11.1 NOT COOLING.....	29
11.2 NOT WORKING OF COMPRESSOR	30
11.3 THERMOSTAT MALFUNCTION-UNDERCOOLING	30
11.4 LIGHT IS NOT ON(NONE)	31
11.5 NOISE	31
12. FIGURES AND DETAILS OF REPAIR PARTS(DOCUMENTS ARE PROVIDED SEPARATELY)	31
12.1 FIGURES.....	31
12.2 LIST OF PARTS AND COMPONENTS.....	31
13. APPENDIX.....	32
13.1 REFRIGERATOR MAINTENANCE TOOLING AND EQUIPMENT AND MATERIAL.....	32

1. Safety Warning Code

1.1 Warning for operation safety

Important Safety Instructions

	CAUTION RISK OF ELECTRIC SHOCK DO NOT OPEN	
	This symbol indicates that dangerous voltage constituting a risk of electric shock is present within your freezer.	
	This symbol indicates that there are important operating and maintenance instructions in the literature accompanying your freezer.	

WARNING

- 1) Read these instructions.
- 2) Keep these instructions.
- 3) Heed all warnings.
- 4) Follow all instructions.
- 5) Do not use this appliance near water.
- 6) Clean only with a damp cloth.
- 7) Do not block any ventilation openings.
- 8) Install in accordance with the manufacturer's instructions.
- 9) Do not install near any heat sources, such as radiators, heat registers, stoves, or other apparatus that produce heat.
- 10) Do not defeat the safety purpose of the polarized or grounding-type plug. A polarized plug has two blades with one wider than the other. A grounding type plug has two blades and a third grounding prong. The wide blade or the third prong are provided for your safety. If the provided plug does not fit into your outlet, consult an electrician for replacement of the obsolete outlet.
- 11) Protect the power cord from being walked on or pinched, particularly at plugs, convenience receptacles, and the point where they exit from the appliance.
- 12) Do not attempt to modify or extend the power cord of this appliance.
- 13) Unplug this appliance during lightning storms or when it will not be used for long periods of time.
- 14) Make sure that the available AC power matches the voltage requirements of this appliance.

CONNECTING ELECTRICITY



Electrical Shock Hazard.

Plug into a grounded 3-prong outlet.
Do not remove the ground prong.
Do not use an adapter.

Failure to follow these instructions can result in death, fire, or electrical shock.



WARNING

Electric Shock Hazard

Failure to follow these instructions can result in electric shock, fire, or death.

- 1) **WARNING**—Keep ventilation openings, in both the freezer and the built-in structure, clear of obstruction.
- 2) **WARNING**—Do not touch the interior of the freezer with wet hands. This could result in frost bite.
- 3) **WARNING**—Do not use mechanical devices or other means to accelerate the defrosting process, other than those recommended by the manufacturer.
- 4) **WARNING**—Do not damage the refrigerant circuit.
- 5) **WARNING**—Do not damage the refrigerant tubing when handling, moving, or using the freezer.
- 6) **WARNING—DANGER**—Never allow children to play with, operate, or crawl inside the freezer. Risk of child entrapment. Before you throw away your old freezer:
 - 6-1) Take off the doors
 - 6-2) Leave the shelves in place so that children may not easily climb inside
- 7) Unplug the freezer before carrying out user maintenance on it.
- 8) This freezer can be used by children age eight years and older and persons with reduced physical or mental capabilities or lack of experience and knowledge if they are given supervision or instruction concerning the use of the freezer in a safe way and understand the hazards involved. Children should not play with the freezer. Cleaning and maintenance should not be performed by children without supervision.
- 9) If a component part is damaged, it must be replaced by the manufacturer, its service agent, or similar qualified persons in order to avoid a hazard.
- 10) Please dispose of the freezer according to local regulations as the freezer contains flammable gas and refrigerant.
- 11) Follow local regulations regarding disposal of the freezer due to flammable refrigerant and gas. All refrigeration products contain refrigerants, which under the guidelines of federal law must be removed before disposal. It is the consumer's responsibility to comply with federal and local regulations when disposing of this product.
- 12) This freezer is intended to be used in household and similar environments.

13) Do not store or use gasoline or any flammable liquids inside or in the vicinity of this freezer.

14) Do not use extension cords or ungrounded (two-prong) adapters with this freezer. If the power cord is too short, have a qualified electrician install an outlet near the freezer. Use of an extension cord can negatively affect the freezer's performance.

Grounding requirement

This freezer must be grounded. This freezer is equipped with a cord having a grounding wire with a grounding plug. The plug must be inserted into an outlet that is properly installed and grounded.

Improper use of the grounding plug can result in a risk of electric shock. Consult a qualified electrician or service person if the grounding instructions are not completely understood, or if doubt exists as to whether the freezer is properly grounded.

1.2 Safety instruction for refrigerant

⚠ WARNING



Explosion Hazard.

Keep flammable materials and vapors, such as gasoline, away from freezer. Failure to do so can result in fire, explosion, or death.



Safety instruction for refrigerant

DANGER—Risk of Fire or Explosion. Flammable Refrigerant Used. To Be Repaired Only By Trained Service Personnel. Do Not Use Mechanical Devices. Do Not Puncture Refrigerant Tubing. CAUTION—Risk of Fire or Explosion. Flammable Refrigerant Used. Consult Repair Manual/Owner's Guide Before Attempting To Service This Product. All Safety Precautions Must be Followed. CAUTION—Risk of Fire or Explosion. Dispose of Properly In Accordance With Federal Or Local Regulations. Flammable Refrigerant Used. CAUTION—Risk of Fire or Explosion Due To Puncture Of Refrigerant Tubing; Follow Handling Instructions Carefully. Flammable Refrigerant Used.

2. Description for product features

This product is provided with following features:

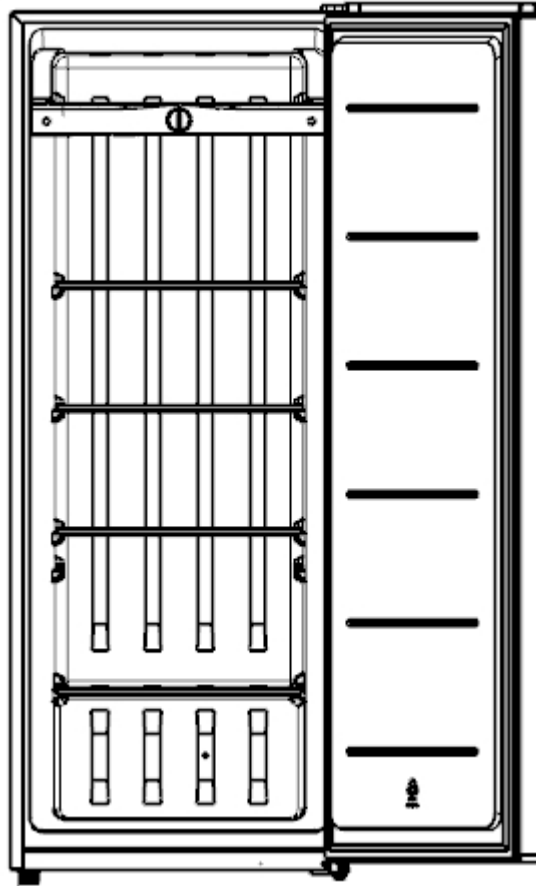

- 1) Mechanical temperature control
- 2) Cooling evenly and quickly;
- 3) Shelf design, increase storage space
- 4) Change the door opening direction

3. Installation and commissioning

3.1 Handling

Handling

- 1) Protect the refrigerator in moving it, Same as shown as left photo, please move it by handcart with cushion
- 2) Remove all packing materials and bottom cushion, then move into house for placement
- 3) After moving it to appropriate location, wait for 2 hours before power on.

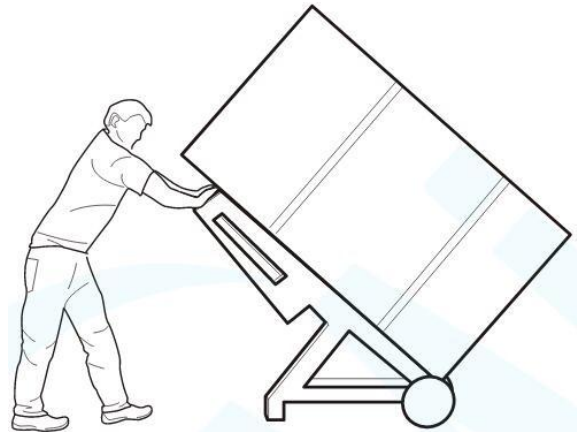

3.2 Door Disassembly and Assembly

The refrigerator door needs to be dismantled if it cannot enter the room in the whole.

Disassembly of Freezer door

Disassembly of Freezer door	None
-----------------------------	------

Disassembly of refrigerator door

Disassembly of refrigerator door	None
----------------------------------	------

3.3 Installation location

Installation location

Location that is easy for ventilation shall be chosen to facilitate heat dissipation, enhance its performance and reduce the energy consumption.

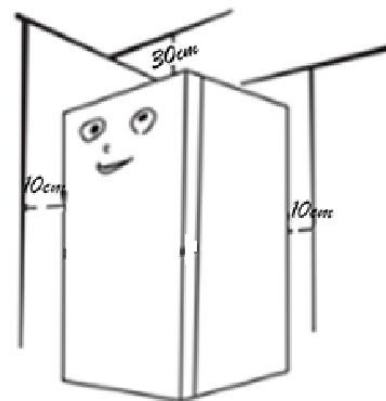

3.4 Leveling of the refrigerator

Leveling of the refrigerator

If the refrigerator cannot be placed steadily, adjust the footing to level it.

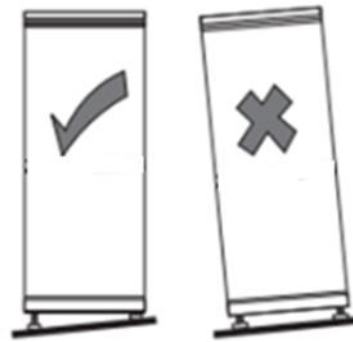

3.5 Door reversal

Door reversal

1) Fix the door by tapes.

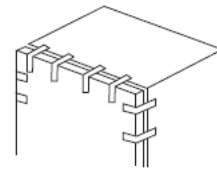

2) Dismantle hinge hole cap, the upper right hinge cover, fitting screws of upper right hinge, and remove the upper right hinge, please keep the door vertical in whole process for avoiding falling.

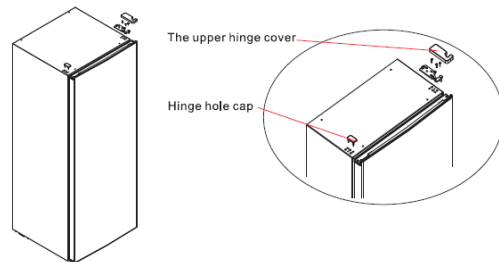

3) Remove the door.



4) Dismantle the door stopper, and install it on other side.

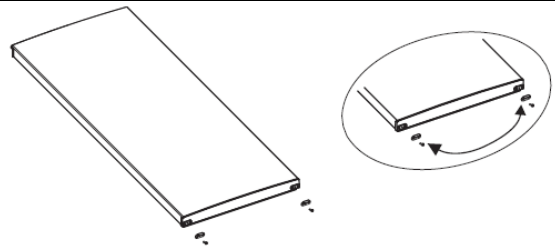

5) Dismantle the lower hinge and adjustable leg.

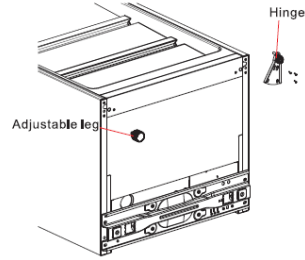

6) Install the lower hinge and adjustable leg on lower left side of cabinet.

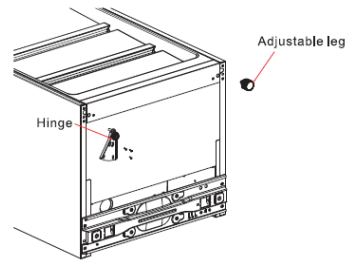

7) Put the door on lower hinge vertically, and validate the gas tightness of door gasket, take out the spare upper left hinge and hinge cover from accessory bag, then install the upper left hinge by fitting screws, finally to install the hinge cover, and cover the hinge hole cap on upper right side.

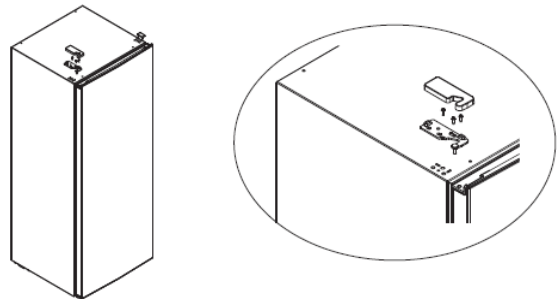

3.6 Installation of handle

Installation of handle

Installation of handle

None

3.7 Installation of door lock

Installation of door lock

Installation of door lock

None

3.8 Adjustment to level the door

Adjustment to level the door

Adjustment to level the door

None

3.9 Adjustment to shelves

Adjustment to shelves

Adjustment to shelves

None

4. Terms

4.1 Definition of model (None)

4.2 Location of nameplate (None)

5. Product specification

5.1 Type specification(None)

5.2 Electrical parameters

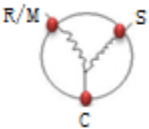
Product Name	UR-BD186-DQ	None	None	None
Product Code	22031010001841	None	None	None
Item	Specification	Specification	Specification	Specification
Compressor				
Compressor	EZ75E1B-U	None	None	None
启动器 Starter(PTC)	QP2-4R7	None	None	None
Overload protector(OLP)	DRB29T61A1	None	None	None
Winding resistance of compressor wiring terminal	Rmc:5.022-5.7785Ω Rsc:6.7053-7.7147Ω Rms=Rmc+Rsc	None	None	None
Winding resistance picture		None	None	None
Variable frequency driver board	None	None	None	None
The input power of compressor	92.7W	None	None	None
Motor				
Fan motor of the freezing chamber	None	None	None	None
Ventilation door of the refrigerating chamber	None	None	None	None
Condensation fan	None	None	None	None
separation the ice motor	None	None	None	None
ice output motor	None	None	None	None
Open door motor	None	None	None	None
Lights inside the refrigerator				
Lights inside the freezing chamber	None	None	None	None
Lights inside the refrigerating chamber	None	None	None	None
Switch of the refrigerator door	None	None	None	None

5.3 Inside temperature

Temperature tolerance $\leq 2^{\circ}\text{C}$

Compartment	The highest ($^{\circ}\text{C}$)	Lowest ($^{\circ}\text{C}$)
Freezing	-12	-24
Refrigerating	None	None
Variable temperature	None	None

5.4 Defrosting parts

Item	Initial defrosting period	Normal defrosting period
Defrosting period	None	None
Defrosting sensor	None	None
Defrosting temperature controller	None	None
Thermal fuse	None	None
Defrosting heater in freezing chamber	None	None

5.5 Circuit diagram

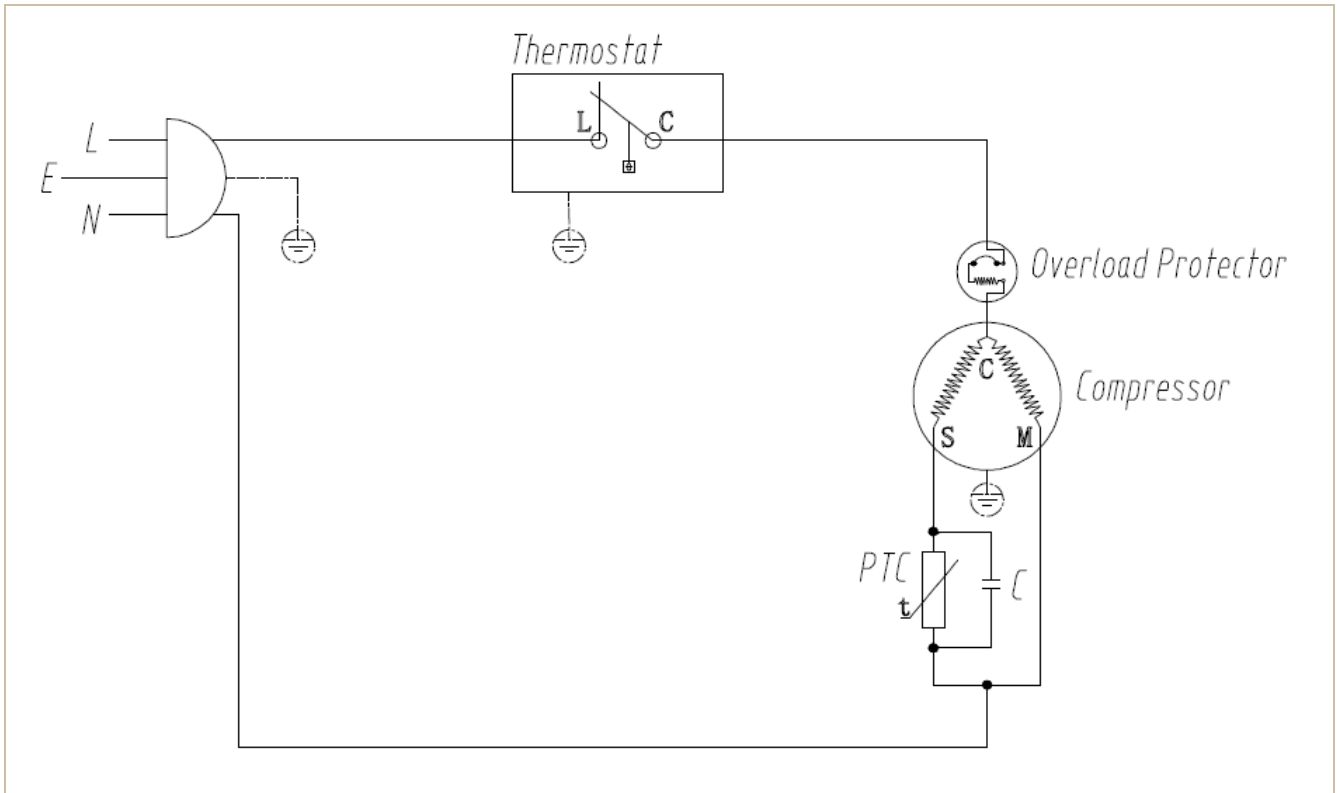

6. Internal view and dimension

6.1 Main parts and their names

Freezer chamber	Refrigerator chamber
① Thermostat box and assembly	None
② Top shelves	
③ Bottom shelf	

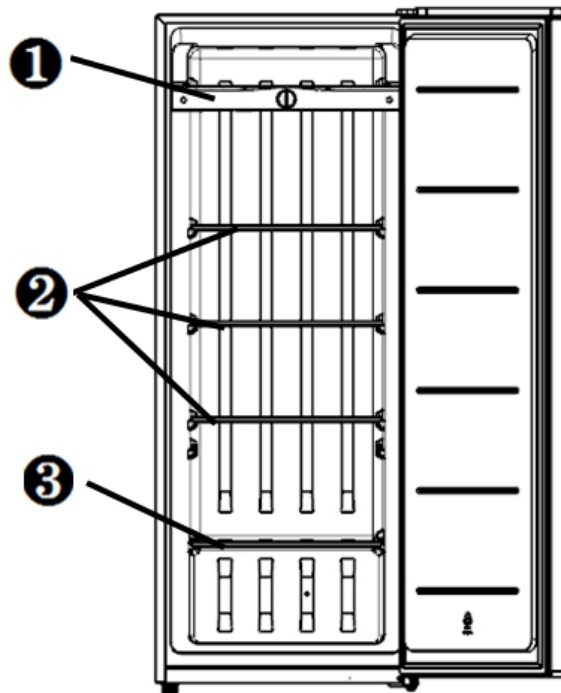

6.2 External dimension

Description	Code	Size (mm)
Height to Top of Case	A	1430
Width	B	545
Depth w/Handles	C	565
Depth (Total with Door Open)	D	1065
Width (door open 90 deg. w/ handle)	E	None

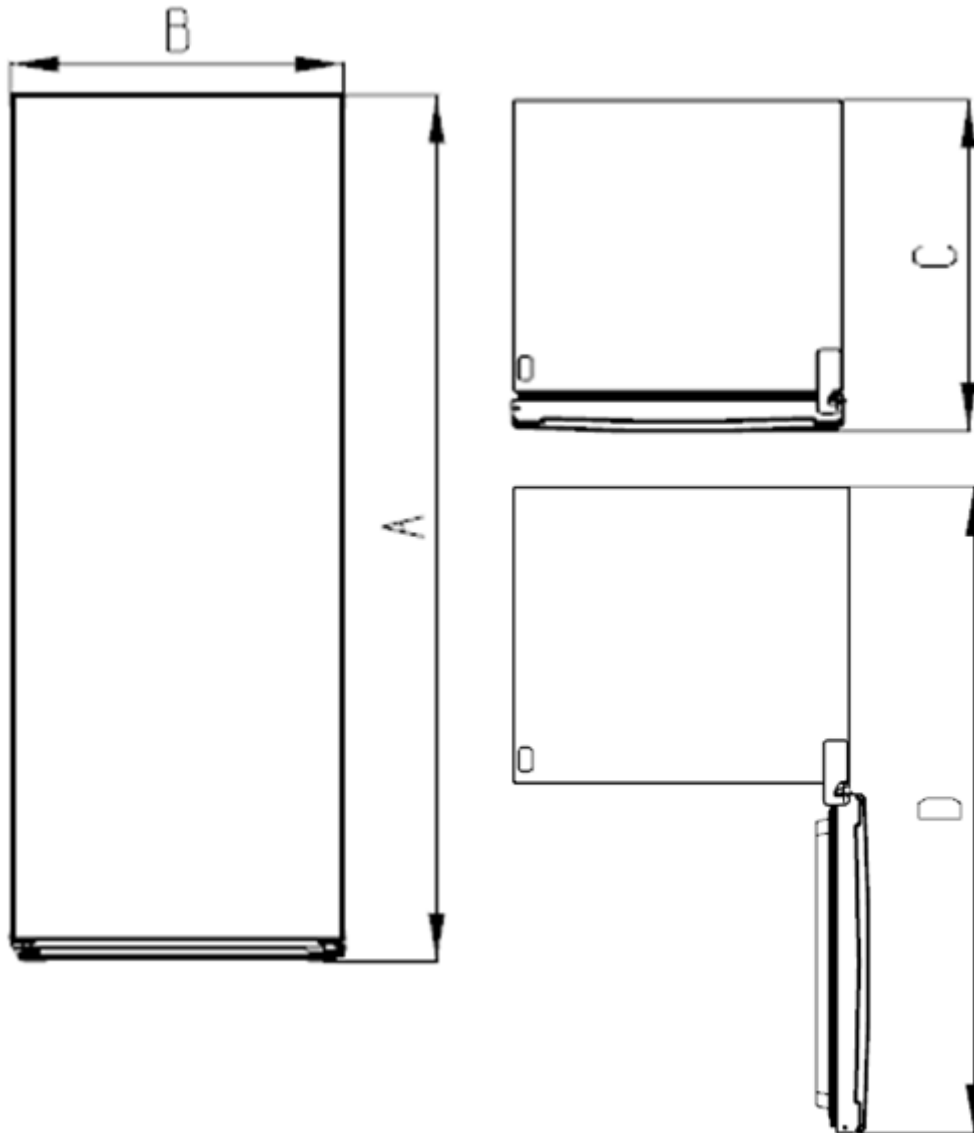

7. Refrigerating piping system and circulating route of cooling air

7.1 Refrigerating piping system

① Compressor → ② Right condenser → ③ Anti-condensation tube → ④ Left Condenser → ⑤ Dry filter → ⑥ Capillary tube → ⑦ Evaporator → ⑧ Suction tube → ① Compressor

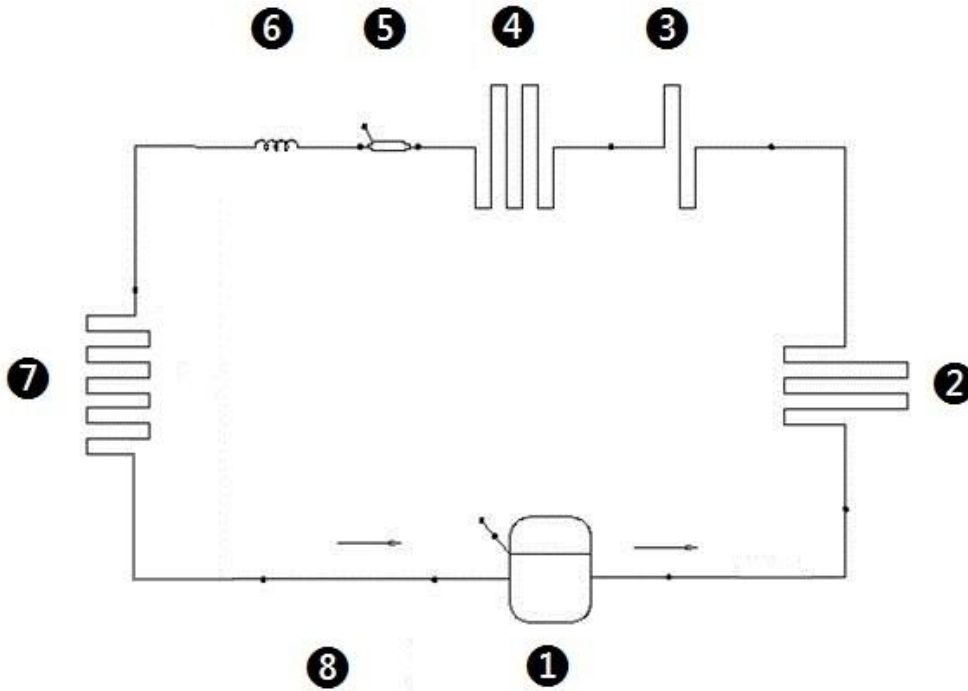

7.2 Circulating route of cooling air (None)

8. Dismantling of parts

8.1 Parts on the door

Door seal

Door seal is installed into door liner groove.

- 1) Open the refrigerator door;
- 2) Take the door seal out of door liner;

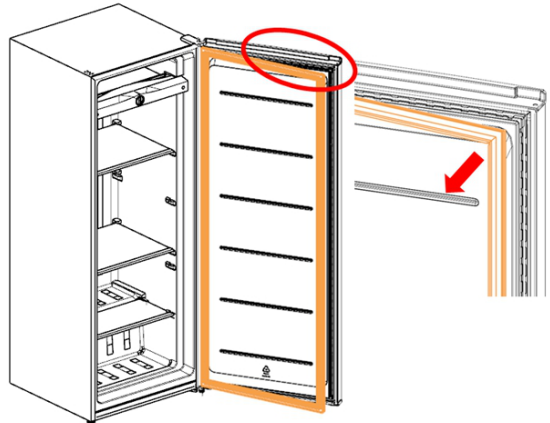

Guardrail

Guardrail

None

Door stopper

Door stopper

None

rollover beam

rollover beam

None

8.2 Parts inside the refrigerator

Drawer

Drawer

None

Refrigerator Fruit box cover

Refrigerator Fruit box cover

None

Shelves

The shelf is located at the freezing 1) Lift it up slightly and take it out from the refrigerator.

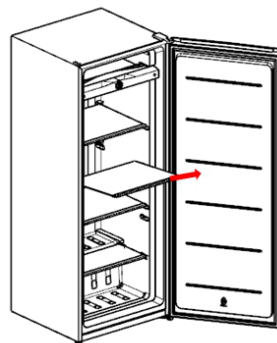

8.3 Light system

Light	
Light	None
Light switch	
Light switch	None
Pilot light	
Pilot light	None
Fresh light	
Fresh light	None

8.4 Air duct components refrigerating chamber

Air duct components refrigerating chamber	
Air duct components refrigerating chamber	None

8.5 Air duct components in freezing chamber and fan motor

Disassembly and installation of Air duct	
Disassembly and installation of Air duct	None
Fan motor of air duct	
Fan motor of air duct	None
Damper assembly	
Damper assembly	None

8.6 Evaporator and temperature sensing system

Evaporator in freezing chamber	
Evaporator in freezing chamber	silk tube evaporator
Components on the evaporator	
Defrost thermostat	None
Fuse	None
Defrost sensor	None
Defrost heater	None
Evaporator in refrigerating chamber	
Evaporator in refrigerating chamber	None
Components on the evaporator	None
Sensor	
Sensor in freezing chamber	None
Sensor in refrigerating chamber	None
Ambient temperature sensor	None
Sensor in Variable temperature chamber	None

Thermostat	
1) Remove the rotary knob, the cap and screw on the thermostat-box assembly	
2) Remove the connector and dismantle the thermostat-box assembly	
3) Remove the thermostat-box panel	
4) Loosen the thermostat fastening screw	
5) Remove the thermostat-box cover and replace the thermostat.	

8.7 Compressor case

Rear cover and compressor case	
Rear cover	None
Compressor and the cooling system pipe	

<p>1) Cut off the power, remove the goods in the refrigerator, with the tape to make the door fixed firmly and prevent the door dropping when the refrigerator dumping.</p>	
<p>2) Slowly tilt the refrigerator forward, relying on the wall or a solid enough object, leaving space to facilitate the operation. For safety, it should be carried by someone to prevent its falling.</p>	
<p>3) Cut off the compressor pipeline.-①Cut off the process pipeline.-②Cut off the low-pressure muffler.-③Cut off the high-pressure exhaust pipe.</p>	
<p>4-1) Remove the screws(for some models) -Two screws outside -One screw inside</p>	
<p>4-2) Remove the metal clamp(for some models) -Disassembly the metal clamp that is fix the electric appliance shield</p>	

5) **Remove the clipping strip**
Slowly pull it out

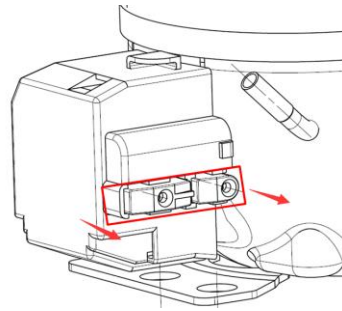

6) **Remove the protective cover**
-Pry the protective cover slowly from the upper part,
-Pull it out and remove it.

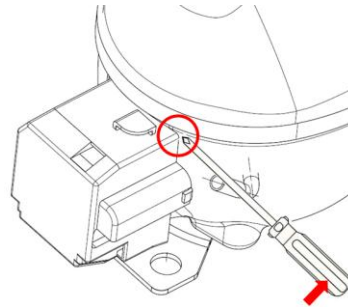

7) **Remove the starter and protector**
Unplug the starter and protector (you can use a screwdriver to pry it slowly)

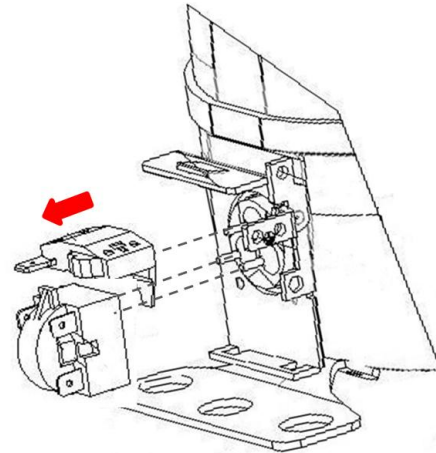

8) Loosen the screw of the compressor bottom plate,
remove the floor together with the compressor from the box.

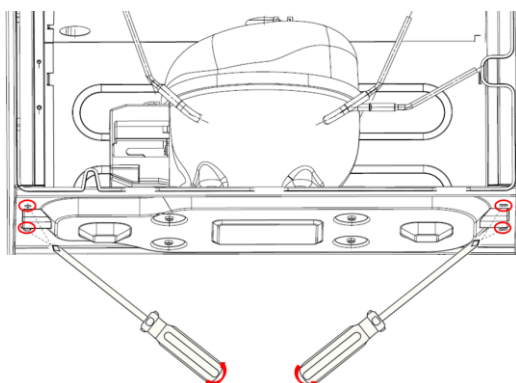

9) Use the wrench to remove the bolts by steps ④⑤⑥⑦, replace the compressor and reverse process can complete installation.

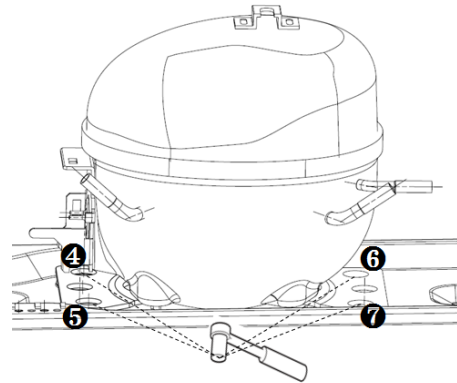

10) Use Pipe cutter cut off the condenser tube ⑧, then Shear off capillary ⑨ by the capillary tube scissors.

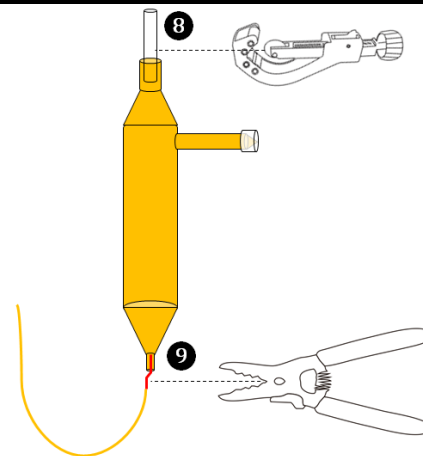

11) Replace the compressor and welding the compressor pipeline.-⑩Welding the process pipeline.-⑪Welding the low-pressure muffler.-⑫Welding the high-pressure exhaust pipe.

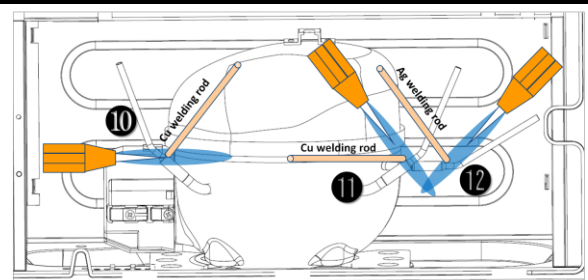

12) Replace the filter, Cu-Fe tubes welding ⑬ used Ag welding rod, Cu-Cu tubes welding ⑭ used Cu welding rod.

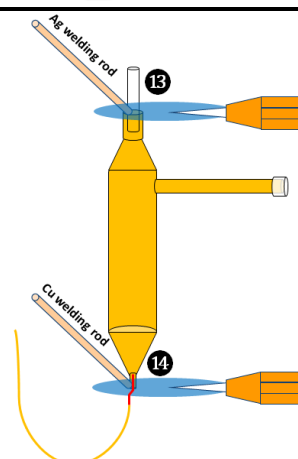

<p>13) Vacuum system, The degree of vacuum below 6Pa.</p>	
<p>14) Perfusion refrigerant.</p>	
<p>15) Use the vise grip pliers clamp the middle of the process pipe, then seal welding process tube 15 16.</p>	

<p>Condenser fan motor</p>	
<p>Condenser fan motor</p>	<p>None</p>
<p>Standby condenser</p>	
<p>Standby condenser</p>	<p>None</p>

<p>Piping system in the compressor case</p>	
<p>① Compressor ② Right condenser ③ Left condenser ④ Anti-dew tupe assembly</p>	<p>⑤ Dry filter ⑥ Suction transition tube</p>

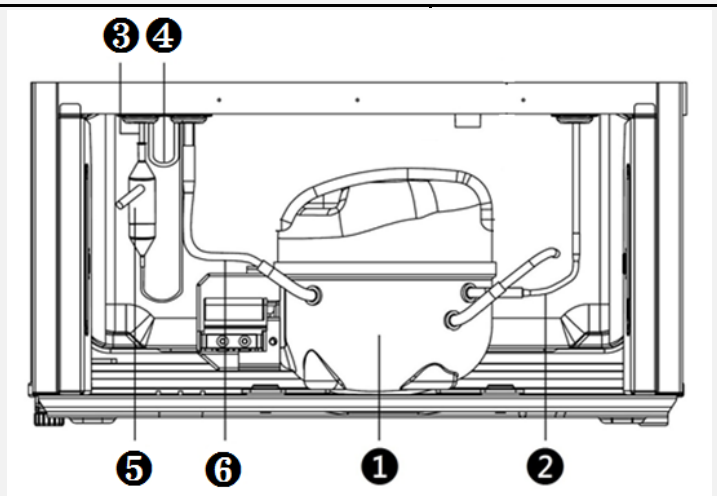

<p>Disassembly and assembly of the drain tray</p>	
<p>Disassembly and assembly of the drain tray</p>	<p>None</p>

8.8 Display control board

Display control board

Display control board	None
-----------------------	------

8.9 Main control board

Main control board

Main control board	None
--------------------	------

8.10 Bar counter

Bar counter

Disassembly and installation of bar counter	None
---	------

Disassembly and installation bar doorseal	None
---	------

8.11 Water dispenser

Water dispenser

Disassembly and installation of water valve	None
---	------

Disassembly and installation of water tank	None
--	------

8.12Ice maker

disassembly of ice maker

Disassembly and installation of ice maker	None
---	------

Disassembly and installation of water system	None
--	------

Disassembly and installation ice machine sensor	None
---	------

9. Function and operation

9.1 Operation panel

Icons	Button
① Max	Ⓐ Temperature control knob
② Mid	
③ Min	

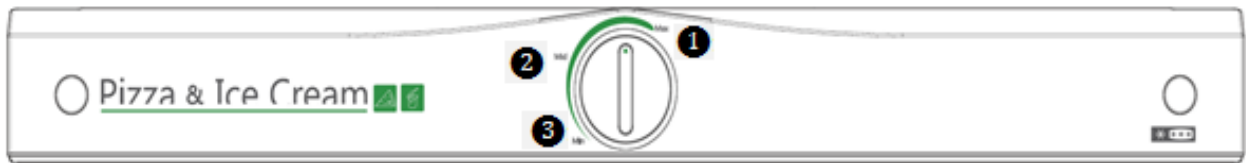

9.2 Temperature control

Direct cooling mechanical refrigerator, through the thermostat knob to adjust the stalls.

Turn the temperature control knob to MAX, the internal temperature of the refrigerator becomes lower.

Turn the temperature control knob to MIN, the internal temperature of the refrigerator becomes higher.

NOTE: Please adjusting and using between "MAX" and "MIN"

9.3 Give an alarm (None)

9.4 Failure code and solutions (None)

9.5 Defrost function

Manual defrost

9.6 Compressor fan control (None)

10. Circuit description

10.1 Power Supply(None)

10.2 Test circuit for door switch(None)

10.3 Temperature test circuit(None)

10.4 Freezer chamber fan motor circuit (None)

10.5 refrigerating chamber fan motor circuit (None)

10.6 Condensation fan circuit (None)

10.7 Fan motor circuit of the ventilation door(None)

10.8 Resistance value of the sensor (R/T) (None)

11. Troubleshooting Method

11.1 Not cooling

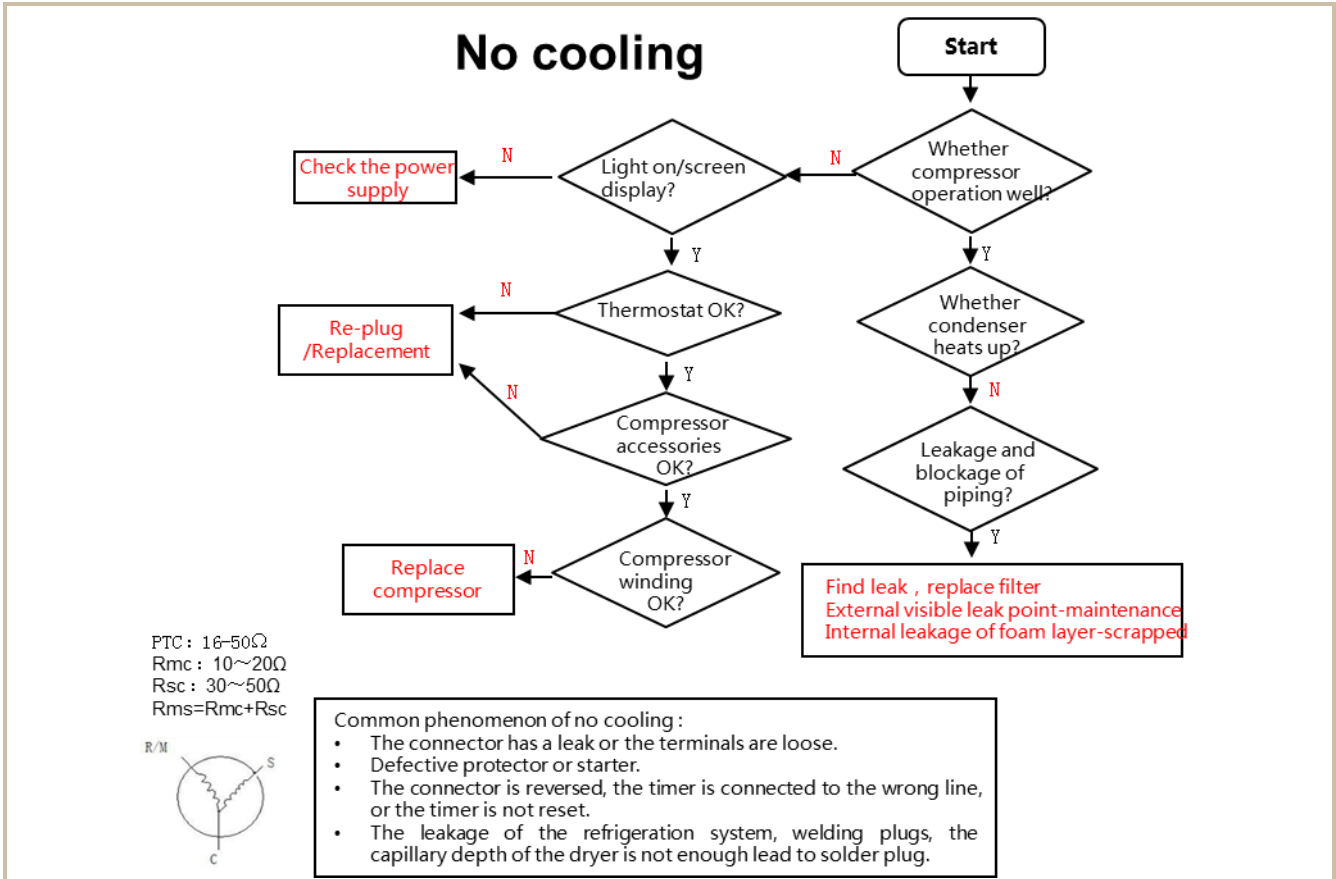

11.2 Not working of compressor

No working of compressor

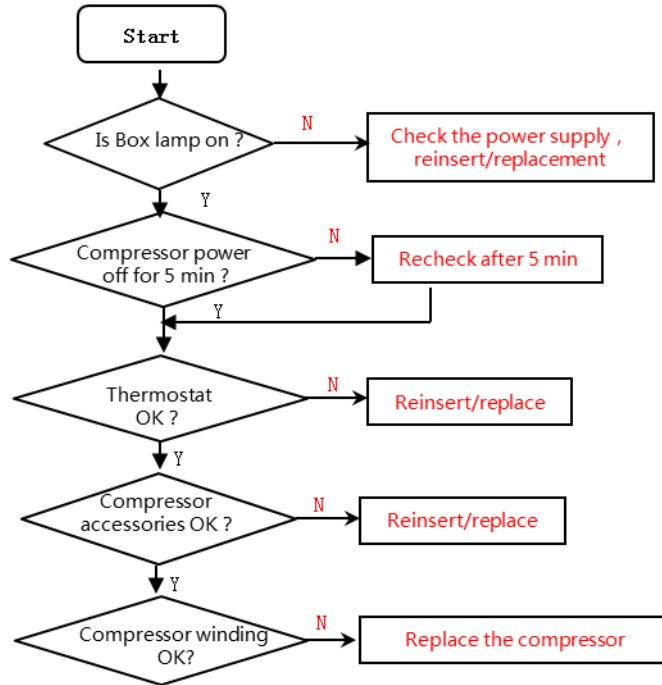

11.3 Thermostat malfunction-Undercooling

Thermostat malfunction-Undercooling

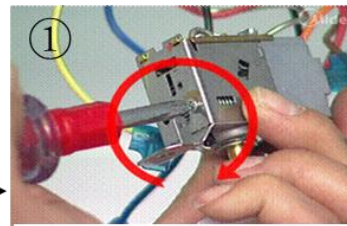
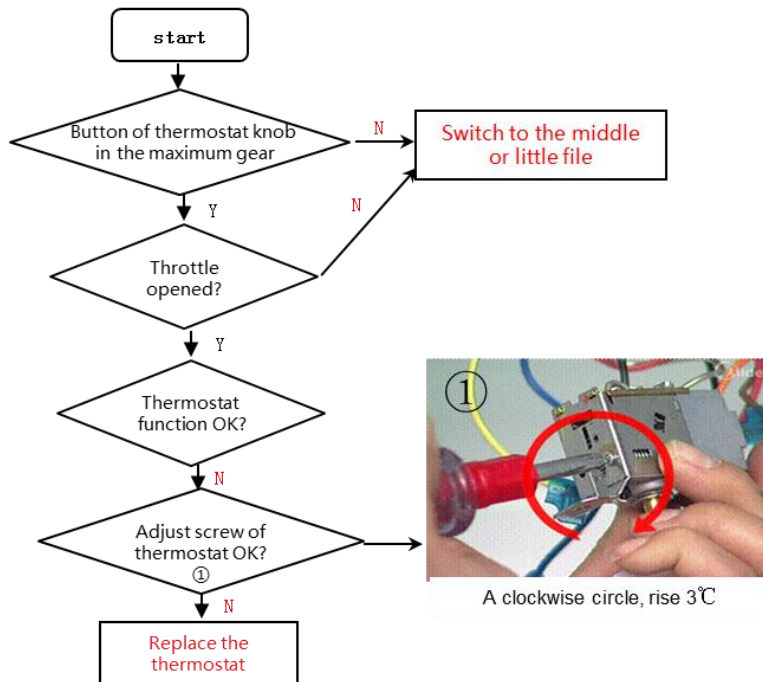

A clockwise circle, rise 3°C

11.4 Light is not on(None)

11.5 Noise

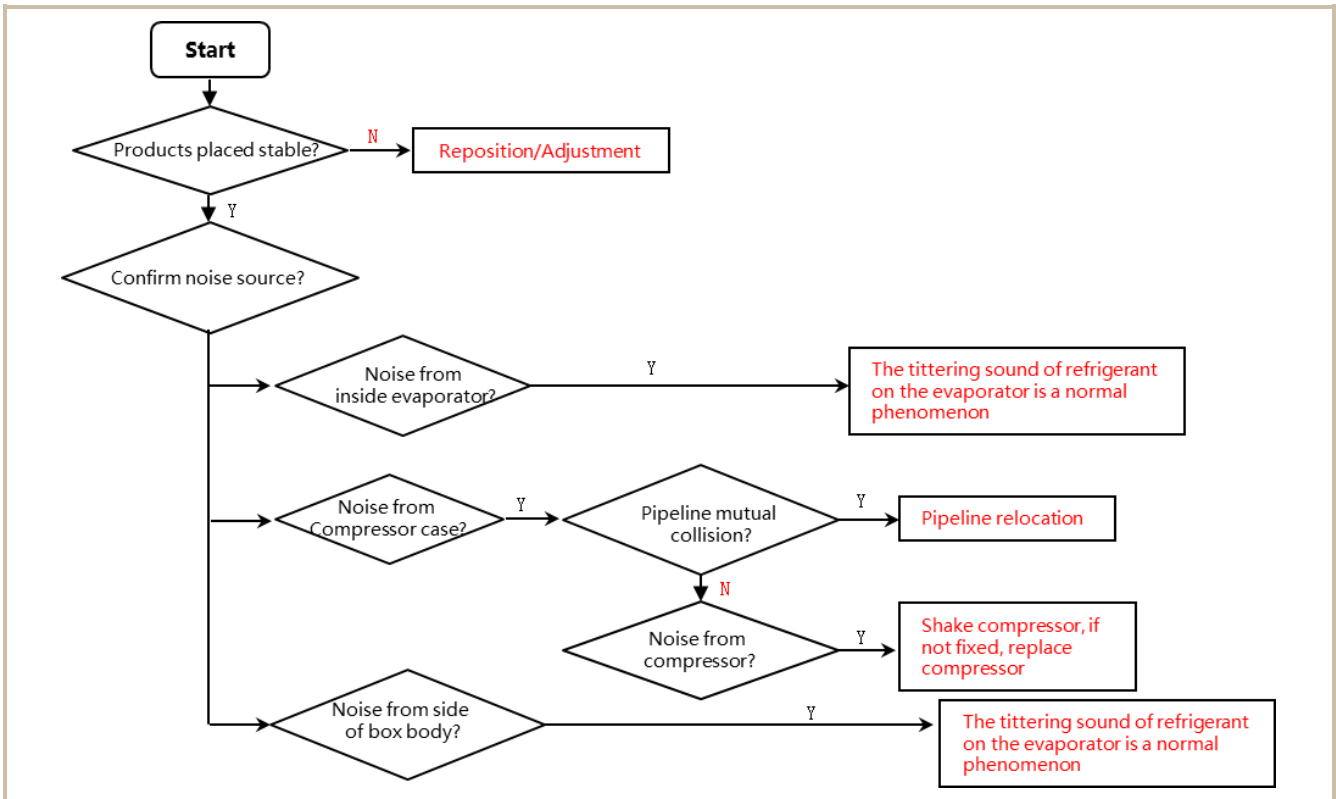

12. Figures and details of repair





parts(Documents are provided separately)

12.1 Figures

12.2 List of parts and components

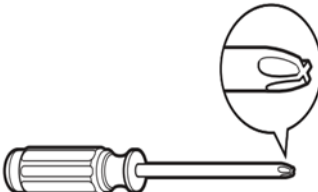
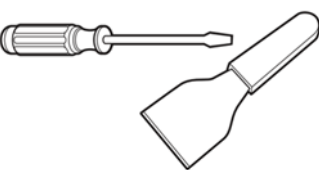
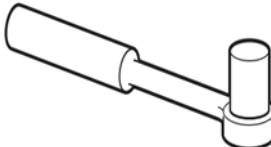

13. Appendix



13.1 Refrigerator maintenance tooling and equipment and material

Tooling			
No.	Name	Main Usage	Photo
1	Phillips screwdriver	screw assemble and disassemble	
2	slotted screwdriver/scrapper	screw and rivet assemble and disassemble	
3	Socket spanner 5/16"	hinge and compressor screw assemble and disassemble	
4	Sucker	display panel and air duct cover disassemble	
5	Allen wrench (2.8~4mm)	handle assemble and disassemble	
6	Vise grip pliers	sealing process tube	
7	Nipper pliers/diagonal pliers	Assistive tooling	





8	Capillary tube scissors	Shear capillary	
9	Knife	assistive tool	
10	Pipe cutter, Flaring device	Pipe cutting, flaring	
11	Electronic digital thermometer	Test temperature	
12	Multi meter	Measurement with resistance, voltage, current and so on.	

Equipment

No.	Name	Main Usage	Photo
1	Vacuum pump with gauge	vacuum pumping	
2	Electronic scale	weighing refrigerant/gas	
3	High pressure nitrogen with piezometer	pipe and cooling system(condenser, evaporator, etc) impurities clean	

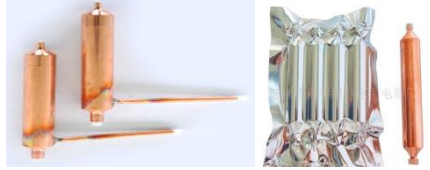
4	Quick coupling	Connection process pipeline, vacuum or charge refrigerant will be used.	
5	Soldering gun	heating and welding	
6	hand leak detector	welding point leakage detect, if no, use soap-suds	

Material

No.	Name	Main Usage	Photo
1	Process pipeline	Charge the refrigerant	
2	Dry filter	Involving a system failure to be replaced	
3	Copper welding rod	Copper-Copper tubes welding	
4	Silver solder(> 25%Ag)	Not Copper-Copper tubes welding	
5	Refrigerant/gas	Add refrigerant to the system	
6	Adhesive tape	Door fixing for reversing door	

7	Transition copper pipe	Aluminium-Aluminium tubes welding, maintain lengthen tubes	
---	------------------------	--	---



The symbol on the product or its packaging indicates that this product must not be disposed of with your other household waste. Instead, it is your responsibility to dispose of your waste equipment by handing it over to a designated collection point for the recycling of waste electrical and electronic equipment. The separate collection and recycling of your waste equipment at the time of disposal will help conserve natural resources and ensure that it is recycled in a manner that protects human health and the environment. For more information about where you can drop off your waste for recycling, please contact your

local authority, or where you purchased your product.



MIDEA appliances after sales website

For more information about Midea appliances after sales, please visit the tsp.midea.com

For more information about the service manual, please visit the tsp.midea.com

For more information about the EV and SBOM, please visit the tsp.midea.com



How to login TSP system

Use Google browser visit the <https://tsp.midea.com/>

Internal User:

Use MIP account and Password.

Customer:

Access: Generated by TSP (provided by administrator).

Password: abcd1234 (please revise after login in).

Midea Refrigerators

If you need to get detailed technical information from the manufacturer, please contact:

xxx@midea.com

Refrigeration Division

Overseas Sales Company

Address: No. 176, Jinxiu Avenue, Economic-Technological Development Area, Hefei, Anhui, China