

Forced Air Holding Cabinet

Original Instructions

Installation, Operation and Maintenance Manual

This manual is updated as new information and models are released. Visit our website for the latest manual.

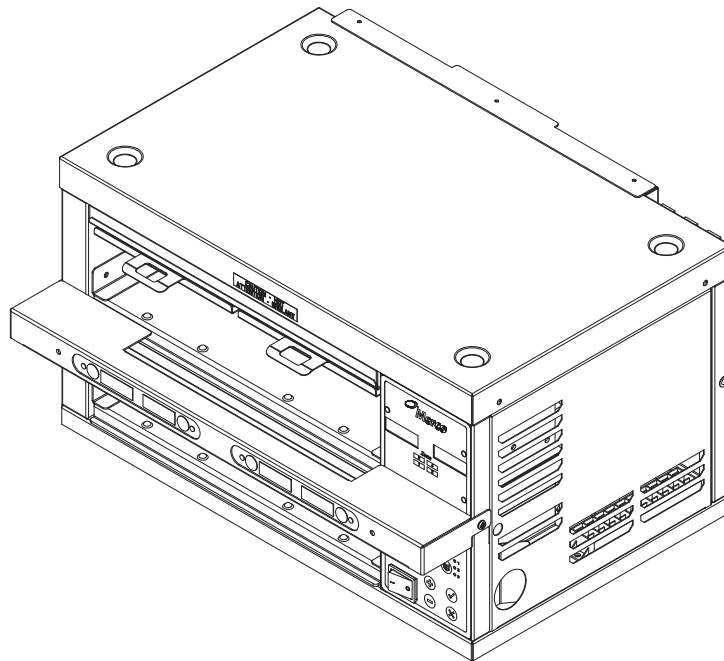

Safety Notices

⚠ Warning

Read this manual thoroughly before operating, installing or performing maintenance on the equipment. Failure to follow instructions in this manual can cause property damage, injury or death.

⚠ DANGER

Do not install or operate equipment that has been misused, abused, neglected, damaged, or altered/modified from that of original manufactured specifications.

⚠ DANGER

Keep power cord AWAY from HEATED surfaces. DO NOT immerse power cord or plug in water. DO NOT let power cord hang over edge of table or counter.

⚠ DANGER

To avoid pacemaker malfunction, consult physician or pacemaker manufacture about effects of microwave energy on pacemaker.

⚠ Warning

Authorized Service Representatives are obligated to follow industry standard safety procedures, including, but not limited to, local/national regulations for disconnection / lock out / tag out procedures for all utilities including electric, gas, water and steam.

⚠ Warning

Do Not Store Or Use Gasoline Or Other Flammable Vapors Or Liquids In The Vicinity Of This Or Any Other Appliance. Never use flammable oil soaked cloths or combustible cleaning solutions, for cleaning.

⚠ Warning

This product contains chemicals known to the State of California to cause cancer and/or birth defects or other reproductive harm. Operation, installation, and servicing of this product could expose you to airborne particles of glasswool or ceramic fibers, crystalline silica, and/or carbon monoxide. Inhalation of airborne particles of glasswool or ceramic fibers is known to the State of California to cause cancer. Inhalation of carbon monoxide is known to the State of California to cause birth defects or other reproductive harm.

⚠ Warning

Do not use electrical appliances or accessories other than those supplied by the manufacturer.

⚠ Warning

Use caution when handling metal surface edges of all equipment.

⚠ Warning

This appliance is not intended for use by persons (including children) with reduced physical, sensory or mental capabilities, or lack of experience and knowledge, unless they have been given supervision concerning use of the appliance by a person responsible for their safety. Do not allow children to play with this appliance.

⚠ Warning

DO NOT use this product near water – for example, near a kitchen sink, in a wet basement, near a swimming pool, or similar locations.

NOTE: Proper installation, care and maintenance are essential for maximum performance and trouble-free operation of your equipment. Visit our website www.mtwkitchencare.com for manual updates, translations, or contact information for service agents in your area.

Table of Contents

Section 1 General Information

Model Numbers	5
Serial Number Information	5
Warranty Information	5
Regulatory Certifications	5

Section 2 Installation

Location	7
Weight of Equipment	8
Clearance Requirements.....	8
Dimensions	8
Electrical Service	9
Voltage, Watts, Rated Amperages & Power Cord Chart	9

Section 3 Operation

Control Panel	12
Controls/Programming/Settings	12
Pre-Heat Mode	12
Active Heating Mode	12
Programming Mode.....	13
Diagnostic Mode	13
Temperature View Mode	13
Temperature Service Mode	13
Time Button	13
Load New Software Via USB	13

Section 4 Maintenance

Cleaning and Sanitizing Procedures.....	15
General.....	15
Exterior Cleaning.....	15
Interior Cleaning.....	16
Plastic Tray Cleaning.....	16
Daily Cleaning Instructions.....	16

Section 5 Troubleshooting

Troubleshooting Chart	19
-----------------------------	----

THIS PAGE INTENTIONALLY LEFT BLANK

Section 1

General Information

Model Numbers

Domestic Models
MHCFA22
MHCFA23
MHCFA24
MHCFA34

Export Item/SKU	Export Models
MHCFA22EX	MHCFA22
MHCFA23EX	MHCFA23
MHCFA24EX	MHCFA24
MHCFA34EX	MHCFA34
MHCFA42EX	MHCFA42

Model Suffix							
Suffix	Control Box		Time Bar			Sided	
	Primary	Secondary	None	R/G Light	A/N	Single	Dual
BP1	X		X			X	
BP2	X		X				X
BS1		X	X			X	
BS2		X	X				X
BP1R	X			X		X	
BP2R	X			X			X
BS1R*		X		X		X	
BS2R*		X		X			X
BP1A	X				X	X	
BP2A	X				X		X
BS1A		X			X	X	
BS2A		X			X		X

NOTE: * Suffixes are not available for MHCFA34 and MHCFA34EX.

Serial Number Information

MHCFA holding cabinet serial and model numbers are located on the data plate. Data plates are located on the bottom and the right end of the unit.

Always have the serial number of your unit available when calling for parts or service.

For ICC time bar and kitchen minder connection questions and issues call - ICC Tech Division 631-673-5100 or 877-422-8788 (North America only).

Warranty Information

Visit http://www.mercoproducts.com/minisite/service/warranty_info to:

- Register your product for warranty.
- Verify warranty information.
- View and download a copy of your warranty.

Regulatory Certifications

Domestic Models are certified by:

- Underwriters Laboratories Sanitation
- Underwriters Laboratories (UL)
- Underwriters Laboratories of Canada (ULC)

Export Models are certified by:

- Underwriters Laboratories Sanitation
- European Conformity
- Technical Inspection Association

THIS PAGE INTENTIONALLY LEFT BLANK

Section 2 Installation

⚠ DANGER

Installation must comply with all applicable fire and health codes in your jurisdiction.

⚠ DANGER

Legs must be installed and the legs must be screwed in completely.

⚠ DANGER

Use appropriate safety equipment during installation and servicing.

⚠ Warning

Only trained and authorized service personnel or store manager should access the service screens. If changes to these settings are made incorrectly they will cause the unit to malfunction.

Location

⚠ Warning

This equipment must be positioned so that the plug is accessible unless other means for disconnection from the power supply (e.g., circuit breaker or disconnect switch) is provided.

⚠ Warning

Adequate means must be provided to limit the movement of this appliance without depending on or transmitting stress to the electrical conduit or gas lines.

⚠ Warning

To avoid instability the installation area must be capable of supporting the combined weight of the equipment and product. Additionally the equipment must be level side to side and front to back.

⚠ Warning

This equipment is intended for indoor use only. Do not install or operate this equipment in outdoor areas.

⚠ Caution

Do not position the air intake vent near steam or heat exhaust of another appliance.

The location selected for the equipment must meet the following criteria. If any of these criteria are not met, select another location.

- Holding cabinets are intended for indoor use only.
- The location **MUST** be level, stable and capable of supporting the weight of the equipment.
- The location **MUST** be free from and clear of combustible materials.
- Equipment **MUST** be level both front to back and side to side.
- Position the equipment so it will not tip or slide.
- Recommended air temperature is 41° - 86°F (5° - 30°C) .
- Proper air supply for ventilation is **REQUIRED AND CRITICAL** for safe and efficient operation. Refer to Clearance Requirements chart on page 8.
- Do not obstruct the flow of ventilation air. Make sure the air vents of the equipment are not blocked.

Weight of Equipment

Domestic Model	Export Item/SKU	Weight
MHCFA22	MHCFA22EX	40lbs/18kg
MHCFA23	MHCFA23EX	65lbs/29kg
MHCFA24	MHCFA24EX	85lbs/39kg
MHCFA34	MHCFA34EX	125lbs/57kg
	MHCFA42EX	85lbs/39kg

Clearance Requirements

DANGER

Minimum clearance requirements are the same for noncombustible locations as for combustible locations. The flooring under the appliance must be made of a noncombustible material.

DANGER

Risk of fire/shock. All minimum clearances must be maintained. Do not obstruct vents or openings.

Sides/Back

1.0" (25mm)

Dimensions

Domestic Model, Export Item/SKU	Length	Depth	Height
MHCFA22, MHCFA22EX	19.56" (497mm)	12.31" (313mm)	11.24" (285mm)
MHCFA23, MHCFA23EX	29.57" (751mm)	12.31" (313mm)	11.24" (285mm)
MHCFA24, MHCFA24EX	36.45" (926mm)	12.31" (313mm)	11.24" (285mm)
MHCFA34, MHCFA34EX	36.45" (926mm)	12.31" (313mm)	15.70" (399mm)
MHCFA42EX	19.56" (497mm)	12.31" (313mm)	20.32" (516mm)

Electrical Service

⚠ DANGER
 Check all wiring connections, including factory terminals, before operation. Connections can become loose during shipment and installation.

⚠ DANGER
 Copper wire suitable for at least 167°F (75°C) must be used for power connections.

⚠ Warning
 This appliance must be grounded and all field wiring must conform to all applicable local and national codes. Refer to rating plate for proper voltage. It is the responsibility of the end user to provide the disconnect means to satisfy the authority having jurisdiction.

VOLTAGE, WATTS, RATED AMPERAGES & POWER CORD CHART

All electrical work, including wire routing and grounding, must conform to local, state and national electrical codes. The following precautions must be observed:

- The equipment must be grounded.
- A separate fuse/circuit breaker must be provided for each unit.
- A qualified electrician must determine proper wire size dependent upon location, materials used and length of run (minimum circuit ampacity can be used to help select the wire size).
- The maximum allowable voltage variation is ±10% of the rated voltage at equipment start-up (when the electrical load is highest).
- Check all green ground screws, cables and wire connections to verify they are tight before start-up.

Units with plugs are supplied with approximately 9ft cords, maximum 10ft.

Domestic Model	Voltage, Cycle, Phase	Watts	Amps	Plug
MHCFA22	120, 60, 1	1920	16.0	5-20P
MHCFA23	208-230, 60, 1	3174	13.8	6-20P
MHCFA24	208-230, 60, 1	3680	16.0	6-20P
MHCFA34	208, 60, 1	3120	15.0	6-20P

Export Item/SKU	Voltage, Cycle, Phase	Watts	Amps	Plug
MHCFA22EX	200-240, 50/60, 1	2472	9.9-10.3	Varies per destination
MHCFA23EX	200-240, 50/60, 1	2856	11.4-11.9	Varies per destination
MHCFA24EX	200-240, 50/60, 1	2784	9.8-11.6	16A pin/sleeve (IEC-60309 16A, 3-pin plug)
MHCFA34EX	200-240, 50/60, 1	3072	10.1-12.8	16A pin/sleeve (IEC-60309 16A, 3-pin plug)
MHCFA42EX	200-240, 50/60, 1	2784	9.8-11.6	16A pin/sleeve (IEC-60309 16A, 3-pin plug)

THIS PAGE INTENTIONALLY LEFT BLANK

Section 3 Operation

DANGER

The on-site supervisor is responsible for ensuring that operators are made aware of the inherent dangers of operating this equipment.

DANGER

Do not operate any appliance with a damaged cord or plug. All repairs must be performed by a qualified service company.

DANGER

Never stand on the unit! They are not designed to hold the weight of an adult, and may collapse or tip if misused in this manner.

Warning

Do not contact moving parts.

Warning

All covers and access panels must be in place and properly secured, before operating this equipment.

Warning

Liquids such as water, coffee, or tea can be overheated beyond the boiling point without appearing to be boiling due to surface tension of the liquid. Visible bubbling or boiling when the container is removed from the microwave oven is not always present. THIS COULD RESULT IN VERY HOT LIQUIDS SUDDENLY BOILING OVER WHEN A SPOON OR OTHER UTENSIL IS INSERTED INTO THE LIQUID. To reduce the risk of injury to persons: Do not overheat the liquid. Stir the liquid both before and halfway through heating it.

Warning

Do not heat sealed containers or plastic bags in oven. Food or liquid could expand quickly and cause container or bag to break. Pierce or open container or bag before heating.

Warning

Racks, utensils, rack guides, and oven surfaces may become hot during or after use. Use utensils or protective clothing, like pan grips or dry oven mitts, when necessary to avoid burns.

Warning

DO NOT use the cavity for storage. DO NOT leave paper products, cooking utensils, or food in the cavity when not in use.

Caution

Do not block the supply and return air grills or the air space around the air grills. Keep plastic wrappings, paper, labels, etc. from being airborne and lodging in the grills. Failure to keep the air grills clear will result in unsatisfactory operation of the system.

Caution

Some products such as whole eggs or sealed containers – for example, closed glass jars – are able to explode and SHOULD NOT be HEATED in this oven. Pressure may build up and erupt. Pierce yolk with fork or knife before cooking. Pierce skin of potatoes, tomatoes, and similar foods before cooking with microwave energy. When skin is pierced, steam escapes evenly.

Caution

DO NOT cover racks or any other part of the oven with metal foil. Airflow restriction will cause overheating of the oven.

Control Panel

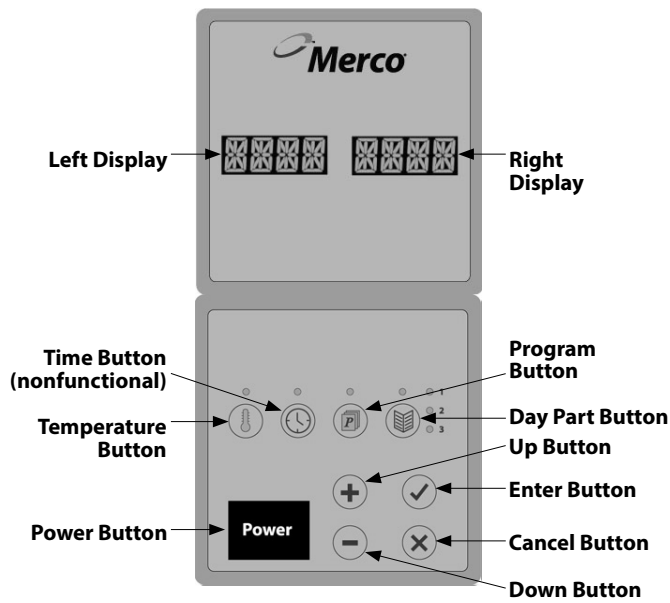

Controls/Programming/Settings

The Merco Holding Cabinet has been designed to afford foodservice operators the ability to cook menu components in advance and then gently store that product in the holding bins until an order is received. Once that order has been placed, the crew can assemble the order using hot and fresh menu components from the holding bins. This allows for operators to serve to order, helping increase speed of service while maintaining high product quality standards.

The holding bin controller is, at all times, operating in one of the following modes. The indents indicate the sub-modes. Sub-modes are defined based on the navigation to the mode. I.e., to get to diagnostic mode you must be in active heating mode then enter programming mode.

- Pre-Heat Mode
- Active Heating Mode
 - Programming Mode
 - » Diagnostic Mode
 - Temperature View Mode
 - » Service Temperature Mode

PRE-HEAT MODE

The displays shall scroll the message Pre-Heating repeatedly during pre-heat mode. The LED corresponding to the active Day Part menu configuration will be on. Once a heater has reached 180°F (82°C), it will be regulated to the set point. The PRE-HEAT mode will be terminated when all of the heaters have reached 180°F (82°C) OR 15 minutes have passed.

During Pre-Heat mode, all button presses will be ignored except the check mark button. If the check mark button is pressed and held for (3) seconds, the displays will scroll the message, Cancel Pre-Heat? If the check mark button is pressed again, the unit will Cancel the Pre-Heat mode and enter Active Heating Mode. If the cancel (X) button is pressed, the unit shall return to Pre-Heat Mode.

ACTIVE HEATING MODE

This is the active heating mode of operation. In active heating mode the displays will be blank and the day part LED light will be ON.

Typical Operator Actions

Action	Instructions
Turn Unit On	Push Power button.
Load bin with product	Pull out tray, load product and reinsert tray.
Empty bin	Pull out tray and remove product. Reinsert tray.

When the unit is first powered ON, the software version will scroll across the display. It will then begin to preheat. Allow it to preheat for 15 minutes, the display will scroll Preheating.

During active heating mode, press enter to scroll the software version on the display.

PROGRAMMING MODE

Press the program button to enter the programming mode. Zone and temperature will display. The zone will flash, press the up or down button to reach the desired zone. Press the day part button until the desired day part LED is ON. Press the temperature button and both the zone and temperature will flash. Press the up or down button to reach the desired temperature. The program button LED light will flash, indicating a program change has occurred. Press enter or the temperature button to return to the zone selection, the zone will flash. Press the program button to exit.

DIAGNOSTIC MODE

From Programming mode, press the program button and hold for 3 seconds to enter Diagnostic Mode.

The software shall track the state of each thermocouple and the state of the thermocouple reading compared to the set point.

If the software finds an error, it will begin to time it. When the timer reaches 15 minutes, an error code(s) will display (flash) on the screen. This shall continue indefinitely.

Turning Off and On a unit will clear all TC State Display flags and reset all TC temp timer's to 0.

TC Display Codes			
Left Display	Right Display		
ZaEr	b_cd		
a	b	c	d
Zone Location with Error	Section of Zone with Error	Thermocouple State	Thermocouple reading compared to Set point
1	U=Upper L=Lower	0 = Ok	0 = Within Range
2		1 = Shorted	1 = Below Range
3		2 = Open	2 = Above Range
4			
5			
6			
7			
8			

TEMPERATURE VIEW MODE

Enter the temperature view mode by pressing the temperature button. The average temperature in the first zone will be displayed. Press the up or down button to scroll through zones. Zones progress from left to right, top to bottom. Press the temperature button or the cancel button to exit.

TEMPERATURE SERVICE MODE

Press the temperature button or when already in the temperature view mode press and the hold temperature button to display the actual thermocouple temperature. This is called the temperature service mode. Press the up or down button to scroll through zones. U stands for upper, L for lower. Press the temperature button or the cancel button to exit.

During temperature service mode if the DOWN button is held for 3 seconds the temperature display shall be replaced with the word OFF, and the zone shall be considered OFF. If a zone is considered OFF, the triac outputs shall be set to off regardless of the thermocouple feedback for that zone. No alarms shall be initiated for a zone that is off.

TIME BUTTON

The time button has no function currently. Time will be displayed on the Timer Bar.

LOAD NEW SOFTWARE VIA USB

Firmware file must be loaded onto the top level of USB.

While the unit is OFF, insert the new software USB into the port. Turn the unit ON by pushing the power button. The unit will detect the software and begin installation. The display will scroll Updating Firmware, then Preheating. When Preheating is scrolling it is clear to remove the USB.

THIS PAGE INTENTIONALLY LEFT BLANK

Section 4 Maintenance

⚠ DANGER

All utility connections and fixtures must be maintained in accordance with Local and national codes.

⚠ DANGER

It is the responsibility of the equipment owner to perform a Personal Protective Equipment Hazard Assessment to ensure adequate protection during maintenance procedures.

⚠ DANGER

Failure to disconnect the power at the main power supply disconnect could result in serious injury or death. The power switch DOES NOT disconnect all incoming power.

⚠ DANGER

Always discharge the ht capacitors before working on the oven using a suitably insulated 10mo resistor.

⚠ DANGER

Disconnect electric power at the main power disconnect for all equipment being serviced. Observe correct polarity of incoming line voltage. Incorrect polarity can lead to erratic operation.

⚠ Warning

When using cleaning fluids or chemicals, rubber gloves and eye protection (and/or face shield) must be worn.

⚠ Caution

Maintenance and servicing work other than cleaning as described in this manual must be done by an authorized service personnel.

Cleaning and Sanitizing Procedures

GENERAL

You are responsible for maintaining the equipment in accordance with the instructions in this manual. Maintenance procedures are not covered by the warranty.

Maintenance	Daily	After Prolonged Shutdown	At Start-Up
Exterior	X	X	X
Interior	X	X	X
Holding Bin, Bin Lid & Jet Plate	X	X	X
Plastic Tray	X	X	X

EXTERIOR CLEANING

⚠ Warning

Never use a high-pressure water jet for cleaning or hose down or flood interior or exterior of units with water. Do not use power cleaning equipment, steel wool, scrapers or wire brushes on stainless steel or painted surfaces.

⚠ Caution

Never use an acid based cleaning solution on exterior panels! Many food products have an acidic content, which can deteriorate the finish. Be sure to clean the stainless steel surfaces of ALL food products.

The stainless steel outer case requires nothing more than a daily wiping with a damp cloth. If, however, an excessive amount of food particles/grease are allowed to collect, a non-abrasive cleaner (hot sudsy water) may be used. Wipe dry with a clean, soft cloth.

Always rub with the "grain" of the stainless steel to avoid marring the finish. Never use steel wool or abrasive pads for cleaning. Never use chlorinated, citrus based or abrasive cleaners.

Stainless steel exterior panels have a clear coating that is stain resistant and easy to clean. Products containing abrasives will damage the coating and scratch the panels. Daily cleaning may be followed by an application of stainless steel cleaner which will eliminate water spotting and fingerprints. Early signs of stainless steel breakdown are small pits and cracks. If this has begun, clean thoroughly and start to apply stainless steel cleaners in attempt to restore the steel.

INTERIOR CLEANING**⚠ Caution**

Do not use caustic cleaners on any part of the oven or oven cavity . Use mild, non abrasive soaps or detergents, applied with a sponge or soft cloth. Never use sharp implements or harsh abrasives on any part of the oven.

The product holding bin, bin lid and jet plate may be cleaned via dishwasher or with warm soapy water. Care must be taken to prevent water or cleaning compounds from getting on internal parts, especially the switches on the control panel.

PLASTIC TRAY CLEANING**⚠ Caution**

Environmental stress cracking can occur, proper dilution and rinsing per detergent manufacturers' directions are mandatory.

Food-approved detergents can be used if they are diluted per manufacturers' directions and adequately rinsed away prior to high temp drying cycle. Basic alcohols such as isopropyl are acceptable for hard-to-remove stains. Otherwise, do not use organic solvents.

DAILY CLEANING INSTRUCTIONS

Unit must be cool to touch and disconnected from power source.



1. Wipe the stainless steel outer case with a damp cloth, rubbing with the grain of the steel. If an excessive amount of food particles/grease has collected, hot sudsy water (non-abrasive) may be used.



2. Remove bins.



- 3. Twist each jet plate assembly lever counter clockwise into the horizontal unlocked position.



- 4. Remove jet plate assemblies.



- 5. The product holding bins, bin lids and jet plates may be cleaned via dishwasher or with warm soapy water.



- 6. Wipe the interior bottom with a damp cloth. If, however, an excessive amount of food particles/grease has collected, hot sudsy water (non-abrasive) may be used.



- 7. Reinstall the cleaned jet plate assemblies.



- 8. Twist each jet plate assembly lever clockwise into the vertical locked position.



- 9. Reinstall the cleaned bins.



- 10. Plug the unit in.



THIS PAGE INTENTIONALLY LEFT BLANK

Section 5 Troubleshooting

Troubleshooting Chart

Problem	Cause	Correction
Cabinet not running	Fuse blown or circuit breaker tripped.	Replace fuse or reset circuit breaker.
	Power cord unplugged.	Plug in power cord.
	Thermostat set too high.	Set thermostat to lower temperature.
	Main power switch turned off.	Turn main power switch on.
Cabinet temperature is too high	Thermostat set too high.	Set thermostat to lower temperature.
	Poor air circulation in cabinet.	Re-arrange product to allow proper air circulation.
	Exterior thermometer is out of calibration.	Re-calibrate thermometer.
Cabinet temperature is too low	Jet plate out of unit.	Reinstall jet plate.
	Pans out of unit.	Reinstall pans in unit.



MERCO
980 SOUTH ISABELLA ROAD, MOUNT PLEASANT, MI 48858

800-678-9511
WWW.MERCOPRODUCTS.COM

Every new piece of Manitowoc Foodservice equipment comes with KitchenCare™ and you choose the level of service that meets your operational needs from one restaurant to multiple locations.

StarCare – Warranty & lifetime service, certified OEM parts, global parts inventory, performance audited

ExtraCare — CareCode, 24/7 Support, online/mobile product information

LifeCare – Install & equipment orientation, planned maintenance, KitchenConnect™, MenuConnect

Talk with KitchenCare™ • 1-844-724-CARE • www.mtwkitchencare.com



To learn how Manitowoc Foodservice and its leading brands can equip you, visit our global web site at www.manitowocfoodservice.com, then discover the regional or local resources available to you.

