

**VULCAN**

*SERVICE MANUAL & CATALOG OF  
REPLACEMENT PARTS*

*ELECTRIC FRYER*

*MODEL*

*MEF24A*

*ML-52836 WITHOUT MELT CYCLE*

*ML-52837 WITH MELT CYCLE*



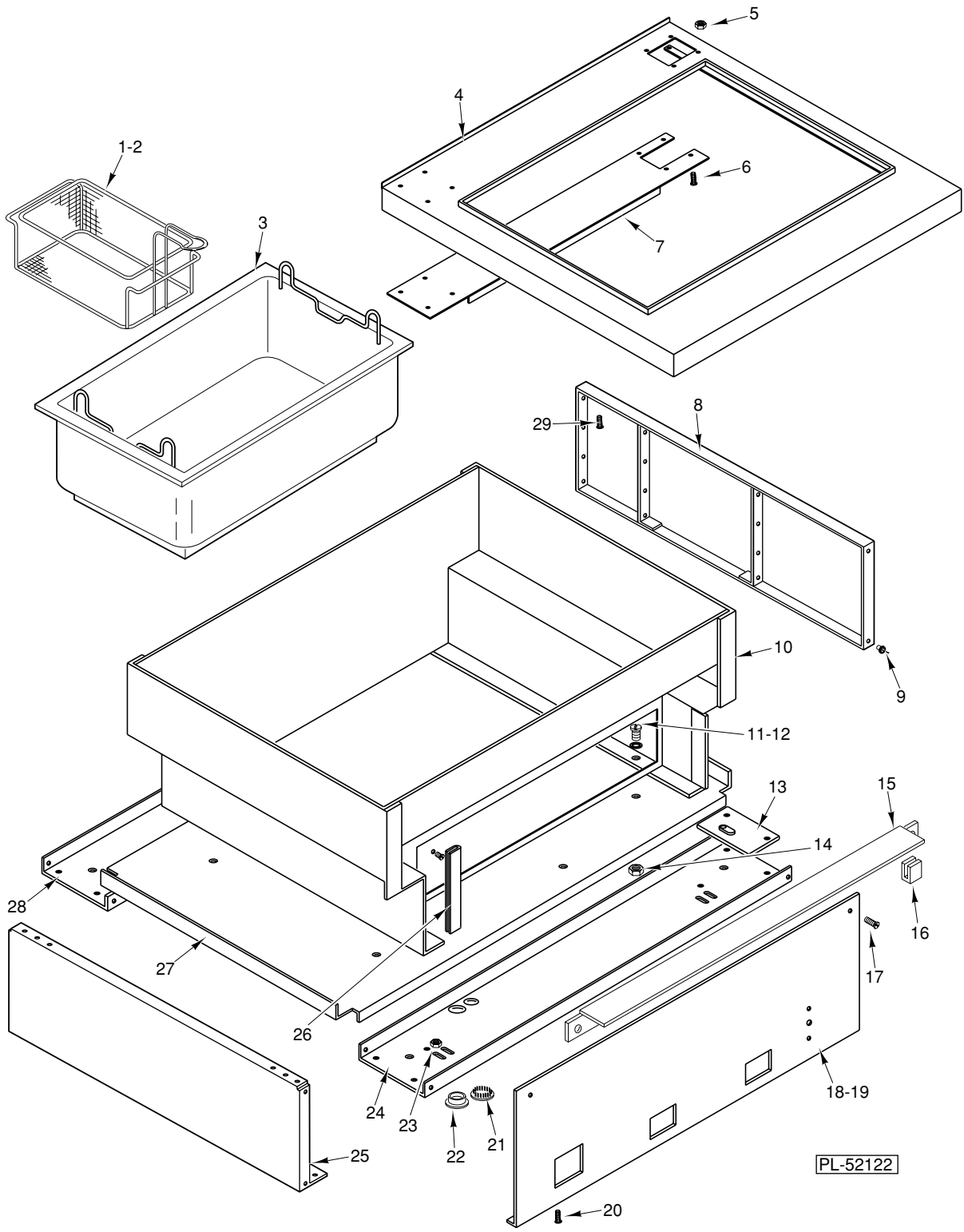

PL-52122

**FRYER BODY**

## FRYER BODY

ILLUS. PL-52122	PART NO.	NAME OF PART	AMT.
1	00-423047-00001	Bracket-Fryer R.H. ....	1
2	00-423047-00002	Bracket-Fryer L.H. ....	1
3	00-346214-00001	Container Assy. ....	1
4	00-423047-00003	Panel-Top ....	1
5	NS-044-09	Nut Assy. 10-24 Hex Keps ....	8
6	SC-067-06	Mach. Screw 10-24 x 1/2 Hex Hd. ....	8
7	00-920358-00001	Top Support Assy. ....	1
8	00-920001-00001	Side Panel Weldment ....	1
9	RS-030-08	Pop Rivet 1/8 x 1/8 SST ....	20
10	00-423047-00006	Liner Weldment ....	1
11	SC-053-05	Mach. Screw 10-24 x 3/8 Truss Hd., Slotted ....	8
12	WS-002-25	Washer ....	8
13	00-920140-00001	Leg Pad Weldment ....	4
14	NS-044-09	Nut Assy. 10-24 Hex Keps ....	8
15	00-920340	Top Cross Angle Weldment ....	1
16	00-911037-00001	"U" Nut ....	2
17	SD-036-71	Self-Tapping Screw 10-16 x 3/8, Type B, Slotted Truss Hd. ....	2
18	00-920552-00001	Front Panel Assy. ....	1
19	00-423047-00007	Front Panel Assy. (W/Melt Cycle) ....	1
20	SC-053-05	Mach. Screw 10-24 x 3/8 Truss Hd., Slotted ....	2
21	00-911510-00006	Plug 7/8" Vent ....	2
22	00-920371	Plug ....	1
23	NS-044-09	Nut Assy. 10-24 Hex Keps ....	4
24	00-423047-00011	Channel-Front & Rear ....	1
25	00-920001-00001	Side Panel Weldment ....	1
26	00-423047-00002	Bracket-Fryer L.H. ....	2
27	00-423047-00013	Cover-Bottom ....	1
28	00-423047-00011	Channel-Front & Rear ....	1
29	SC-053-05	Mach. Screw 10-24 x 3/8 Truss Hd., Slotted ....	2

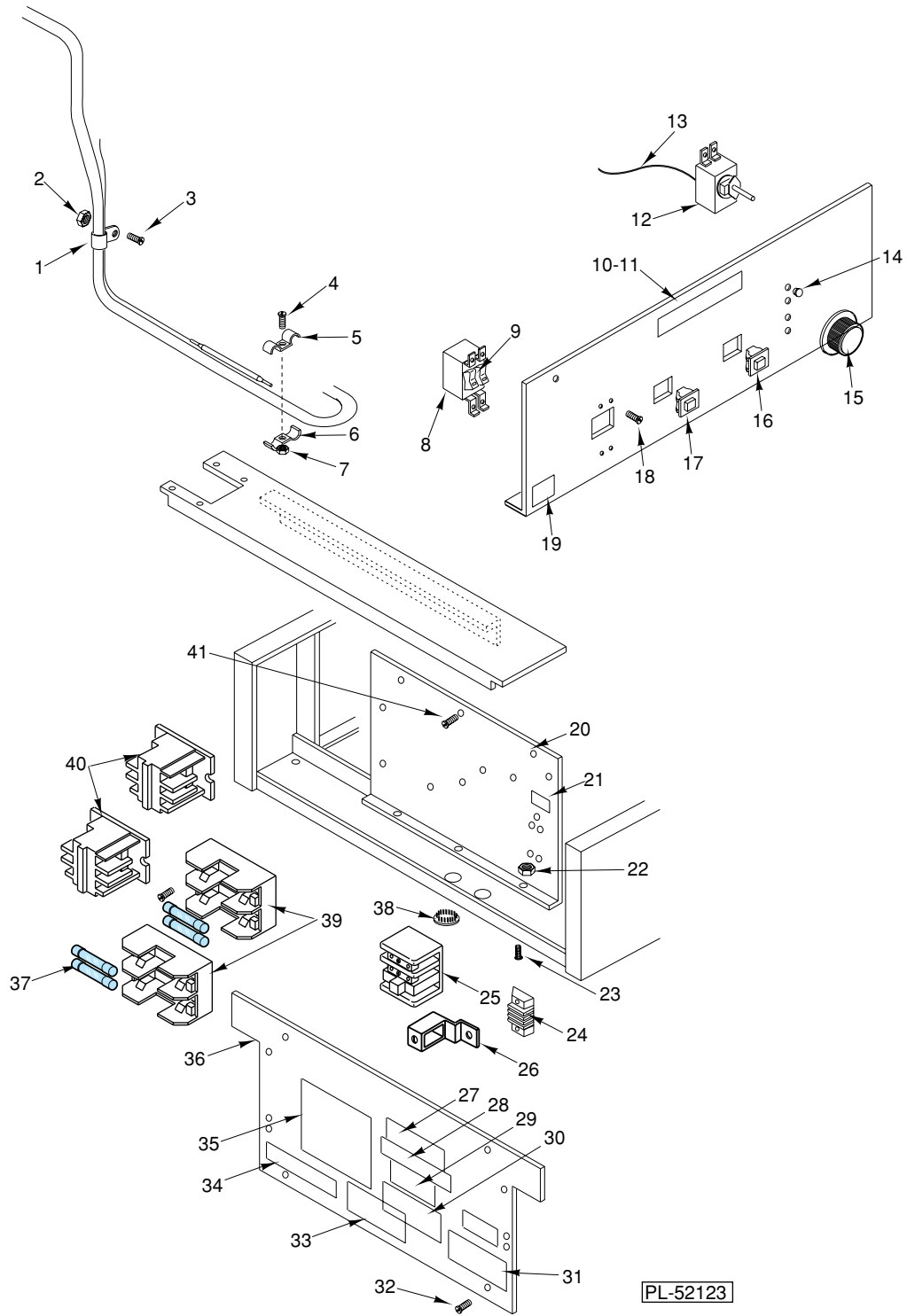

**ELECTRICAL COMPONENTS**

## ELECTRICAL COMPONENTS

ILLUS. PL-52123	PART NO.	NAME OF PART	AMT.
1	00-804752	Clamp-Tube .....	3
2	NS-011-07	Mach. Nut 6-32 Hex .....	3
3	SC-114-83	Mach. Screw 6-32 x 1/4 Pan Hd. ....	3
4	SC-109-10	Mach. Screw 6-32 x 3/8 Pan Hd. ....	2
5	00-801128	Clamp-Thermostat Bulb .....	2
6	00-801128	Clamp-Thermostat Bulb .....	2
7	NS-011-07	Mach. Nut 6-32 Hex .....	2
8	00-920343	Breaker-Circuit .....	1
9	00-920121	Label-Reset .....	2
10	00-417700-00003	Nameplate .....	1
11	NS-047-68	Lock Nut 1/8 .....	2
12	00-920349	Thermostat .....	1
13	00-920350	Spring-Thermostat .....	1
14	PB-004-69	Plug-Hole .....	1
15	00-920394	Knob-Control .....	1
16	00-920477	Light-Amber Indicator .....	1
17	00-920476	Switch-Lighted Red Pushbutton .....	1
18	SC-109-10	Mach. Screw 6-32 x 3/8 Pan Hd. ....	4
19	00-805995	Label .....	1
20	00-920373	Contacto-Mounting Panel .....	1
21	00-920545	Label-Connection .....	1
22	NS-044-09	Nut Assy. 10-24 Hex Keps .....	2
23	SC-053-05	Mach. Screw 10-24 x 3/8 Truss Hd., Slotted .....	3
24	00-920541	Strip - Terminal .....	1
25	00-825126-00040	Block-Terminal .....	1
26	FE-023-68	Lug-Solderless .....	1
27	00-920524	Label .....	1
28	00-920544	Label Fuse Warning .....	1
29	00-805780	Marker-Supply .....	1
30	00-908805	Label-Ground Warning .....	1
31	00-825368	Plate-Serial Number .....	1
32	SD-036-71	Self-Tapping Screw 10-16 x 3/8, Type B, Slotted Truss Hd. ....	2
33	00-805782	Label-Disconnect Power .....	1
34	00-348189-00004	Label-Stock .....	1
35	00-920378-00010	Label-Wiring Diagram .....	1
36	00-920342	Panel-Rear .....	1
37	00-920543	Fuse .....	4
38	00-911510-00006	Plug 7/8" Vent .....	2
39	00-920542	Block-Fuse .....	2
40	00-920360	Contacto-Magnetic .....	2
41	SC-053-05	Mach. Screw 10-24 x 3/8 Truss Hd., Slotted .....	3
	00-423047-00009	Switch-Melt .....	1
	00-423047-00008	Switch-Pushbutton (Melt) .....	1
	00-423047-00010	Switch-Infinite (Melt) .....	1

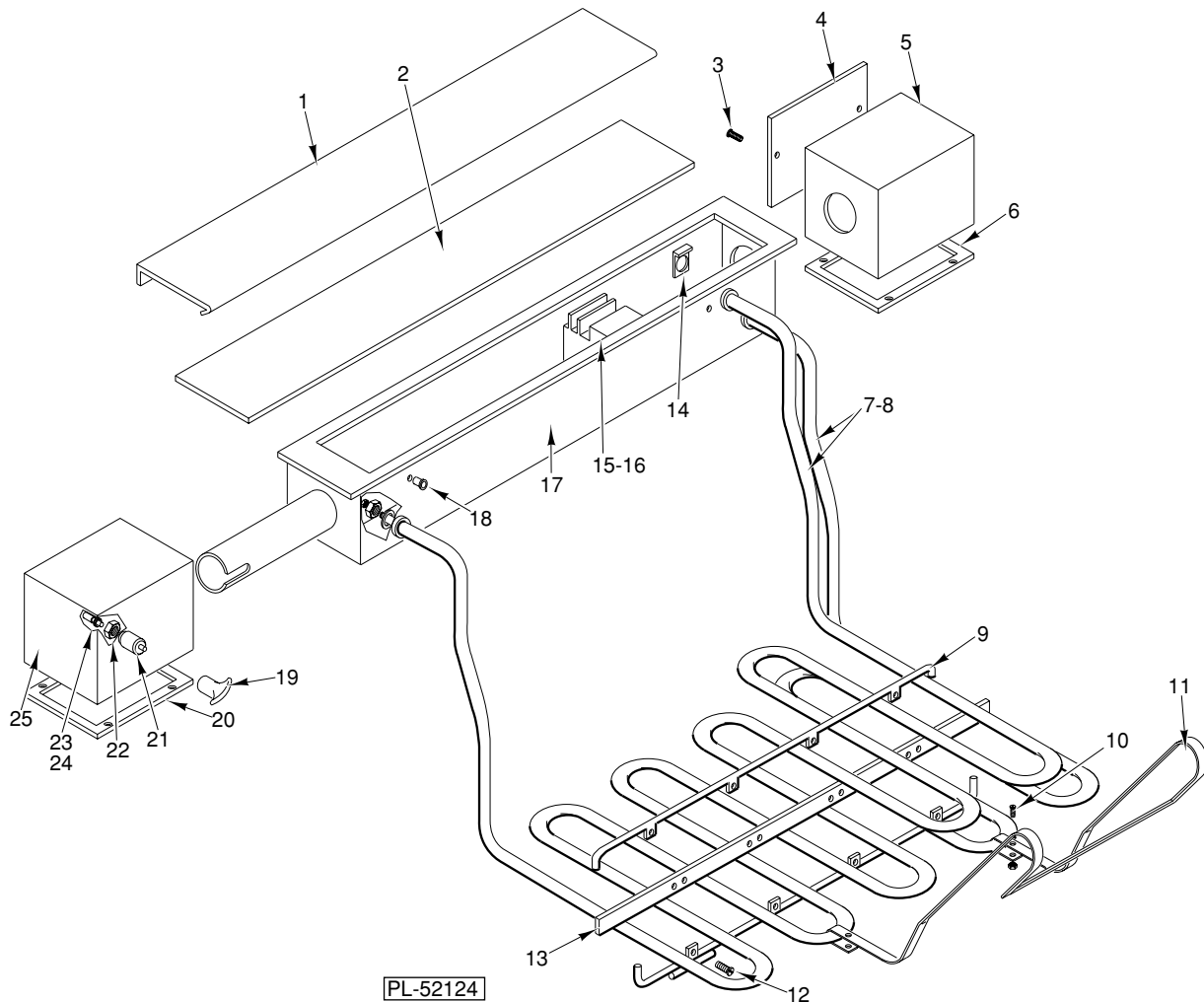

**HEATING ELEMENTS**

## HEATING ELEMENTS

ILLUS. PL-52124	PART NO.	NAME OF PART	AMT.
1	00-920370	Cover-Pivotal Head .....	1
2	00-920365	Gasket-Pivotal Head .....	1
3	SC-053-05	Mach. Screw 10-24 x 3/8 Truss Hd., Slotted .....	2
4	00-920467	Cover-End Post Back .....	1
5	00-920666-00001	Post-Thermostat End .....	1
6	00-920468	Gasket-End Post .....	1
7	00-920125-00010	Element (6000 W, 208V) .....	2
8	00-920125-00011	Element (6000 W, 240V) .....	2
9	00-920472-00001	Support-Element .....	2
10	SC-119-64	Mach. Screw 8-32 x 1 Slotted Truss Hd. ....	2
11	00-423047-00015	Handle-Element Lift .....	1
12	SC-053-05	Mach. Screw 10-24 x 3/8 Truss Hd., Slotted .....	8
13	00-920474	Bar-Element Clamp .....	1
14	00-920547	Clamp-Capillary Bulb .....	1
15	00-804735	Switch-High Limit .....	1
16	00-911033-00023	Screw-Sheet Metal 7 x 3/8 .....	2
17	00-920662-00001	Pivot-Head Weldment .....	1
18	00-345689-00002	Grommet .....	2
19	00-920402	Knob-Pull .....	1
20	00-920468	Gasket-End Post .....	1
21	00-920368	Body-Plunger .....	1
22	NS-047-64	Stop Nut 5/8-18 Hex .....	1
23	00-920365	Gasket-Pivotal Head .....	1
24	00-920369	Plunger .....	1
25	00-920660	Post-Locking End .....	1

# MEF24A ELECTRIC MEDIUM DUTY FRYER

## SERVICE

**WARNING:** HOT OIL AND PARTS CAN CAUSE BURNS. USE CARE WHEN OPERATING, CLEANING OR SERVICING THE FRYER.

**WARNING:** SPILLING HOT OIL CAN CAUSE SEVERE BURNS. DO NOT MOVE FRYER WITHOUT DRAINING ALL OIL FROM THE TANK.

**WARNING:** DISCONNECT ELECTRICAL POWER SUPPLY AND PLACE A TAG AT THE DISCONNECT SWITCH TO INDICATE THAT YOU ARE WORKING ON THE CIRCUIT BEFORE PERFORMING ANY SERVICE.

### CHECKING THERMOSTAT CALIBRATION

The fryer thermostat is carefully calibrated at the factory so that dial settings match actual frying compound temperatures. Field recalibration is seldom necessary, unless the fryer has been mishandled in transit or abused. Recalibration should not be resorted to unless considerable experience with cooking results definitely proves that the control is not maintaining the temperature to which the dial is set.

1. To check frying compound temperatures when recalibrating, use a precision test instrument, or a good grade mercury thermometer. Fill fry tank with frying compound to "FULL" mark.
2. Check frying compound temperature at the center of the tank, approximately 1" to 1½" below surface of frying compound.
3. Turn dial of thermostat being checked to the 350°F mark.
4. Allow temperature to stabilize, or until thermostat cycles to OFF three times after starting with cold frying compound. With power ON, read highest and lowest frying compound temperature, as thermostat cycles through at least two cycles. Average the reading.
5. Thermostat should be recalibrated if temperature reading is not within 10 degrees of the control knob setting (350°F plus or minus 10°F). If recalibration is required, continue with steps 6, 7, 8 and 9.
6. Remove control knob by grasping outer edge and pulling straight out, without twisting or turning.
7. Hold thermostat dial shaft "B" (Fig. 1) stationary with pliers, and with a screwdriver, turn screw "A" (Fig. 1) clockwise to obtain a lower temperature, or counterclockwise for higher temperature. Each ¼ turn (90° rotation) of screw "A" represents 18°F.
8. Replace thermostat control knob.
9. Recheck thermostat as in Steps 4 and 5 above. If the frying compound temperature is not within 20 degrees of dial setting (350°F plus or minus 20°F), it means that the sensing element is inoperative, and the thermostatic control should be replaced.

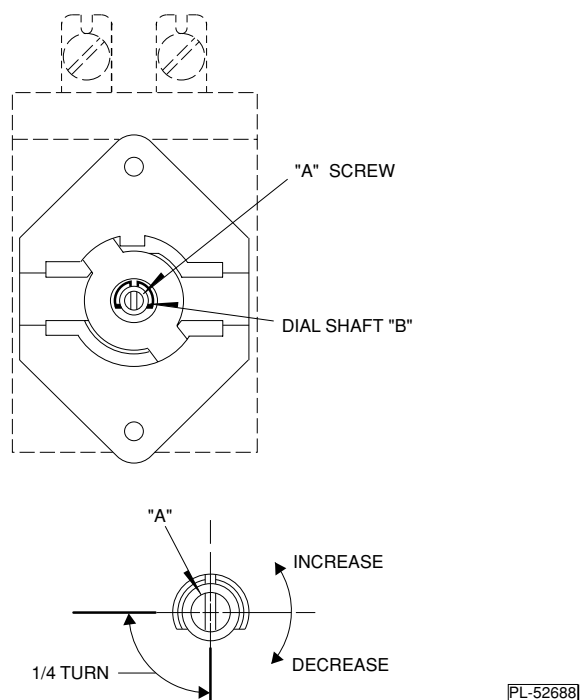

Fig. 1

### REPLACING RED ON-OFF SWITCH, YELLOW CYCLING LIGHT OR CIRCUIT BREAKER. (ALSO WHITE "MELT ON" SWITCH AND MELT CYCLE CONTROL ASSEMBLY FOR MELT CYCLE OPERATION)

1. Remove thermostat control knob by grasping outer edge and pulling straight out, without twisting or turning.
2. Remove two screws at top of front panel. Pull top edge to open.
3. Disconnect leads to switch, light or circuit breaker, and remove the damaged component. Mark disconnected leads to identify them.
4. Mount the new circuit breaker (or melt cycle control) with fasteners provided. The new switch, or light, is snapped into place from the front of the panel.
5. Connect leads to corresponding terminals on new component. Check completed circuit against circuit diagram on rear panel.
6. Reverse steps 1 and 2 to close front panel.

### REPLACING MAGNETIC CONTACTOR, TERMINAL BLOCK, GROUND LUG OR AUXILIARY TERMINAL BLOCK

1. Remove four screws securing rear panel to fryer. Let the rear panel fall down straight before pulling it out.
2. Disconnect leads to the damaged component.
3. Connect the leads to corresponding terminal on the new component.
4. Remove screws securing the damaged component to the mounting panel.

5. Remove the damaged component and install a new component in the same position.
6. Check completed circuit against circuit diagram on rear panel.
7. Mount the rear panel and put fryer in operation.

#### **REPLACING BLOWN FUSES OR FUSE BLOCK**

1. Remove four screws securing rear panel to fryer. Let rear panel fall down straight before pulling it out.
2. Remove damaged fuses and replace with 40 Ampere one time fuse.
3. To replace fuse block, remove fuses and disconnect wire leads to the damaged fuse block. Mark disconnected leads to identify them.
4. Replace new fuse block in the same position.
5. Connect leads to corresponding terminal on new fuse block. Check completed circuit against circuit diagram on rear panel.

#### **REPLACING ELEMENT**

1. Remove screws securing pivotal head cover to pivotal head. Remove pivotal head cover and gasket.
2. Lift up the elements to drain position.
3. Remove thermostat bulb and capillary tube clamps.
4. Remove element support assembly.
5. Disconnect leads to element and mark them for identification.
6. Remove the element retaining nuts inside the pivotal head.
7. Remove element. Mount the new element and reverse steps 1 through 6 to reassemble.

#### **REPLACING HI-LIMIT THERMOSTAT**

1. Remove screws securing pivotal head cover to pivotal head. Remove pivotal head cover and gasket.
2. Remove Hi-Limit thermostat bulb and capillary tube clamps from element.
3. Dislodge capillary bushing from hole in pivotal head.
4. Remove bushing and thread the thermostat capillary and bulb through hole in pivotal head.
5. Disconnect leads to the damaged Hi-Limit thermostat and transfer them to corresponding leads on new thermostat.
6. Remove screws securing the thermostat.
7. Secure new Hi-Limit thermostat with screws and reverse steps 1 through 4 to reassemble.

**REPLACING CYCLING THERMOSTAT**

1. Remove thermostat control knob by grasping outer edge and pulling straight out without twisting or turning.
2. Remove two screws at top of front panel. Pull top edge to open.
3. Remove four screws securing rear panel to fryer. Let rear panel fall down straight before pulling it out.
4. Remove screws securing pivotal head cover to pivotal head. Remove pivotal head cover and gasket.
5. Remove cover on back of end post, located on right rear corner of fryer.
6. Remove Hi-Limit thermostat bulb and capillary tube clamps from element.
7. Dislodge capillary bushing from hole in pivotal head.
8. Remove bushing and thread the thermostat capillary and bulb through hole in pivotal head.
9. Disconnect nuts securing thermostat coil to end post and to pivotal head. Both are accessible from rear of end post.
10. Disconnect leads to the damaged thermostat and mark them for identification.
11. Remove screws securing thermostat to front panel.
12. Maneuver the thermostat to rear of fryer (through right side passage), and then into the right side end post (through opening on top panel).
13. Remove thermostat, along with bulb and capillary, from the opening on back of right side end post.
14. Wind thermostat coil (supplied with new thermostat) around capillary of new thermostat at approximately the same position from bulb as on the damaged thermostat. The thermostat coil should cover approximately 11" to 12" of capillary length.
15. Wrap the portion of thermostat capillary which is covered by the thermostat coil into approximately two turns of 1 $\frac{1}{2}$ " to 2" diameter.
16. Reassemble the thermostat by reversing steps 1 through 13.

Required replacement parts should be ordered by part numbers as shown on parts list in this manual.

