

Service Manual



Pitco Frialator

ELECTRIC FRYER with FILTER MODEL ME14S-C/MFD MANUFACTURED EXCLUSIVELY FOR McDONALD'S®



PITCO FRIALATOR, INC.

P.O. BOX 501 CONCORD, NH 03302-0501

Phone: 1(603)225-6684

Toll Free: 1(800)258-3708

Fax: 1(603)225-8497



NOTICES

There are three different types of notices that you should be familiar with, a NOTICE, CAUTION, and WARNING. A NOTICE is a special note used to call attention to a particularly important point. CAUTION is used to point out a procedure or operation which may cause equipment damage. The WARNING notice is the most important of the three because it warns of an operation that may cause personal injury. Please familiarize yourself with your new cooker before operating it and heed the notices throughout this manual. The WARNINGS are listed below and on the following page for your review prior to operating the unit.

FOR YOUR SAFETY

DO NOT store or use gasoline or other flammable vapors or liquids in the vicinity of this or any other appliance.

WARNING:

Improper installation, adjustment, alteration, service or maintenance can cause property damage, injury or death. Read the installation, operating and maintenance thoroughly before installing or servicing this equipment.

THIS MANUAL MUST BE RETAINED FOR FUTURE REFERENCE

SAFETY

SAFETY

SAFETY

SAFETY

SAFETY

WARNING

The fryer must be electrically grounded in accordance with local codes. If local codes do not apply follow the requirements of National Code ANSI/NFPA 70-1990

WARNING

Before connecting any fryer make sure that all the circuit breakers for the appliance(s) are OPEN or OFF. NEVER connect the fryer with power applied to the power lines. Some appliances have more than one power supply. Make sure they are ALL disconnected.

WARNING

The heating elements MUST be covered with water or oil before they are turned on. NEVER turn on the fryer unless the elements are covered by at least one inch of liquid. For the Element Burn OFF Procedure refer to the operation manual.

WARNING

Never melt blocks of shortening on top of the heating elements. This will cause a fire, and void your warranty.

WARNING

Water and shortening DO NOT mix. Keep liquids away from hot shortening. Dropping liquid frozen food into the hot shortening will cause violent boiling.

WARNING

At operating temperature the shortening temperature will be greater than 300°F. Extreme care should be used when filtering operating temperature shortening to avoid personnel injury.

WARNING

Follow the filtering procedures carefully when filtering, these can be found in the operating manual. Before handling any parts after filtering make sure they have cooled to room temperature.

WARNING

All power supplies must be disconnected before servicing. Some appliances have more than one power supply. Make sure they are ALL disconnected.

WARNING

DANGER - HIGH VOLTAGE PRESENT

NEVER remove the entrance box cover unless all power to the appliance has been disconnected.

SAFETY

SAFETY

SAFETY

SAFETY

SAFETY

Table of Contents

Table of Contents	i
Warranty Statement	1
Chapter 1: INSTALLATION INSTRUCTIONS	2
Ventilation	2
Clearances	2
Once the fryers are in place	2
Filling the fryer with oil	3
Set Up	3
Shut Down	3
Chapter 2: HOW DOES IT WORK?	4
Heating System	4
Hi - Limit System	4
Filter System	5
Hood Relay System	5
Chapter 3: COMPONENT TROUBLESHOOTING	5
Probe	5
Relays	6
Hi Limits	6
Drain Valve & Return Valve Switches	6
Transformer	6
Elements	6
Contactor	6
Chapter 4: TROUBLESHOOTING	7
Fryers	7
Filters	8
Chapter 5: COMPONENT CHANGEOUT	9
Probe	9
Hi Limit	9
Elements	9
Components mounted in the front panel	9
Heat Demand Relays	10
Circuit Breaker	10
Hood & Filter Relays	10
Control relays	11
Proximity Switches	11
Filter Pumps	11
Chapter 6: PARTS SECTION	12
Chapter 7: SCHEMATICS	39

WARRANTY STATEMENT

Pitco Frialator, Inc. makes the following limited warranties to the original purchaser only for this equipment and replacement parts:

1. **WARRANTY PROVISIONS - FRYERS**
 - A. Pitco Frialator, Inc. warrants all parts, with the exception of the frypot, elements and computer for 1 year after the date of installation of the fryer.
 - B. If any parts become defective during the first year after the installation date, Pitco Frialator will also pay for the labor, freight and travel costs involved in replacing said part.

2. **WARRANTY PROVISIONS - FRYPOTS**
 - A. If a frypot develops a leak due to a defect in material or workmanship within the first 10 years after installation, Pitco Frialator, Inc. will either weld or replace, at its discretion, the frypot.
 - B. The customer will be responsible for all freight, labor and travel charges for this repair, except within the period stated in section 1-B.

3. **WARRANTY PROVISIONS - COMPUTER**
 - A. Pitco Frialator, Inc. will warrant the Intelli-fry Computer from defects in material or workmanship for a period of two years.
 - B. If the computer is found to be defective during the first 2 years after the installation date, Pitco Frialator Inc. will also pay for the labor, freight and travel costs involved in replacing said part.

4. **WARRANTY PROVISIONS - ELEMENTS**
 - A. Pitco Frialator, Inc. will warrant the Electric Elements from defects in material or workmanship for a period of 3 years.
 - B. The customer will be responsible for all freight, labor and travel charges for this repair, except within the period stated in section 1-B.

Retain this manual for future reference.

INSTALLATION INSTRUCTIONS

CAUTION:

This equipment is manufactured for the use on a particular voltage and phase which is specified on the rating plate located on the inside of the door.

When your fryers arrive, look them over carefully noting any damage on the freight bill. If concealed damage is found after you have accepted the equipment, report it to the carrier immediately as all claims must be filled within 15 days of the receipt of the shipment. Also, be sure to keep all packing materials as these will be necessary to make any claim.

Follow these installation instructions carefully. A proper installation is important for the operation of the fryers.

All installations must conform to all local and state codes and well as the United States National Electrical Code (ANSI/N.F.P.A. No. 70-1987). In Canada, installations must be made in accordance to Canadian Electrical Code Part I, CSA-C22.1.

Do not block the area around the casters and under the fryers. Contact the Authorized Pitco Frialator representative for any service related problems. Routine maintenance may be performed by qualified personnel.

The duct system, the hood system and the fryers must be cleaned on a regular basis and must be kept clear of any grease build up. See the appropriate Maintenance Requirements Cards.

Ventilation:

A proper ventilation system is also an important part of the installation. For information on the construction and installation of ventilating hoods, please see "Standard for the Installation of Equipment for the Removal of Smoke and Grease Laden Vapors from Commercial Cooking Equipment", N.F.P.A. No. 96-1987. Copies can be obtained by writing to the National Fire Protection Association, Battery March Park, Quincy, MA 02269

Clearances:

Minimum clearance of 6" (15cm) must be maintained from combustible construction on each side and the rear of the equipment. This equipment may be installed on combustible floors.

Maintain a minimum of 24" (61cm) clearance in front of the fryer to provide for proper operation, maintenance and servicing.

Wiring diagram(s) are located in the back of the service manual and inside the fryers.

The control (interlock) voltage for this equipment must be 120VAC (US & Canada). For other countries please check the rating plate.

Regular cleaning of this equipment, as well as the hood, is an important part of proper maintenance. Refer to Maintenance Requirement Cards for proper procedure and frequency.

Once the fryers are in place:

Leveling the fryers will help ensure proper operation. To level the fryers loosen the two set screws on the caster stem. Rotate the collar of the caster to raise or lower the height of the unit. Tighten set screws to lock the adjustment. Casters should be adjusted so that the fryers are level and at the correct height under the hood system.

Clean the fry tanks using the Boil Out procedure on Maintenance Card 14A.

A wiring diagram is located in the back of this manual and inside the fryers.

EQUIPMENT SET UP AND SHUT DOWN PROCEDURES

NOTE: Should you experience a power failure, your fryers will shut off automatically. Once the power has been restored, press the  key to turn the fryer back ON. If the machine is being filtered, close the RED return valve so that the filter does not run if the machine is left unattended. Do not attempt to restart the fryers until the power is restored.

Filling the fryer with oil:

It is very important to make sure the oil level is correct before attempting to heat shortening in your Pitco fryer.

Liquid shortening can be poured directly into the fry tank until the correct level has been reached. This is indicated by a line on the right hand side of the inside of the tank.

NOTE: The “C” (Cold) level is considered to be the “MINIMUM” oil level and the “H” (Hot) level is considered to be the “MAXIMUM” oil level.



For solid shortening, the shortening must be cut into small blocks about 1" (2.54 Cm) in size. These small blocks must be placed under and around the heating elements.

The fryer can now be turned ON.

Set-Up:

NOTE: Please read the Operating instructions thoroughly before attempting to operate this equipment.

Make sure the power cords are plugged into the correct receptacles and the proper building circuit breakers are turned ON.

Press the  key on either side of the full vat computer, or the right  key for the right side and the left  key for the left side of a split vat computer to turn the unit ON.

The computer display will light and the heating elements will begin to heat and will be controlled by the computer/controller.

NOTE: From a cold start the fryer will automatically begin a melt cycle. This is a condition where the computer will heat the shortening in small controlled bursts of heat. Once the predetermined temperature has been reached, the unit will exit the melt cycle and go to normal operation. The melt cycle cannot be overridden.

Make sure that the shortening is at the proper level **after** cooking temperature has been reached. It may

be necessary to add shortening to maintain the proper level.

NOTE: When adding solid shortening to an empty fry tank, first remove the baskets and support racks and fill the bottom of the tank with shortening, continue to pack the remaining shortening into the tank. Place the basket support rack on top of the shortening before turning the unit ON.

For liquid shortening fill to the level lines indicated on the side of the tank.

Shut Down:

Press the corresponding  key to turn the fryer OFF. The Computer display will show "OFF" and all heating functions will cease.

NOTE: When the fryer is not being used, place the cover over the fry tank.

Chapter 1: HOW DOES IT WORK?

The McDonalds Electric fryer will have certain reactions to what is happening, knowing what these reactions are and knowing what the machine is trying to do will enable us to diagnose most of the problems likely to be encountered.

Heating System

Power to the machine is turned ON:

The computer is supplied with 24VAC and, if the Drain Valve Handle is closed, the Proximity Switch (S3) will supply 24 VAC to the DVI (Drain Valve Interlock) Input at the computer.

The computer is turned ON:

The first computer in the "battery" of fryers (this includes either side of a split vat) to be turned ON will

energize a Relay (K15) that will turn the Hood system ON. The Power On Relay (K2) will be energized, closing the circuit. If the Hi Limit (S1) is NOT tripped the Safety Contactor (K10) will energize.

Computer calls for heat:

The Heat Demand Relay (K1) will energize supplying the Heat Demand Contactors (K4, K5 & K6) with 24 VAC. This will also supply the computer with a heat feedback signal.

Hi Limit System:

When the Hi Limit (S1) trips it causes the Relay (K3) to energize opening the supply voltage circuit to the Safety (K10) and Heat Demand (K4, K5 & K6) Contactors. This Relay (K3) has a loop circuit that will cause it to stay energized until the Hi Limit (S1) resets and the power to the machine is turned OFF and back ON again.

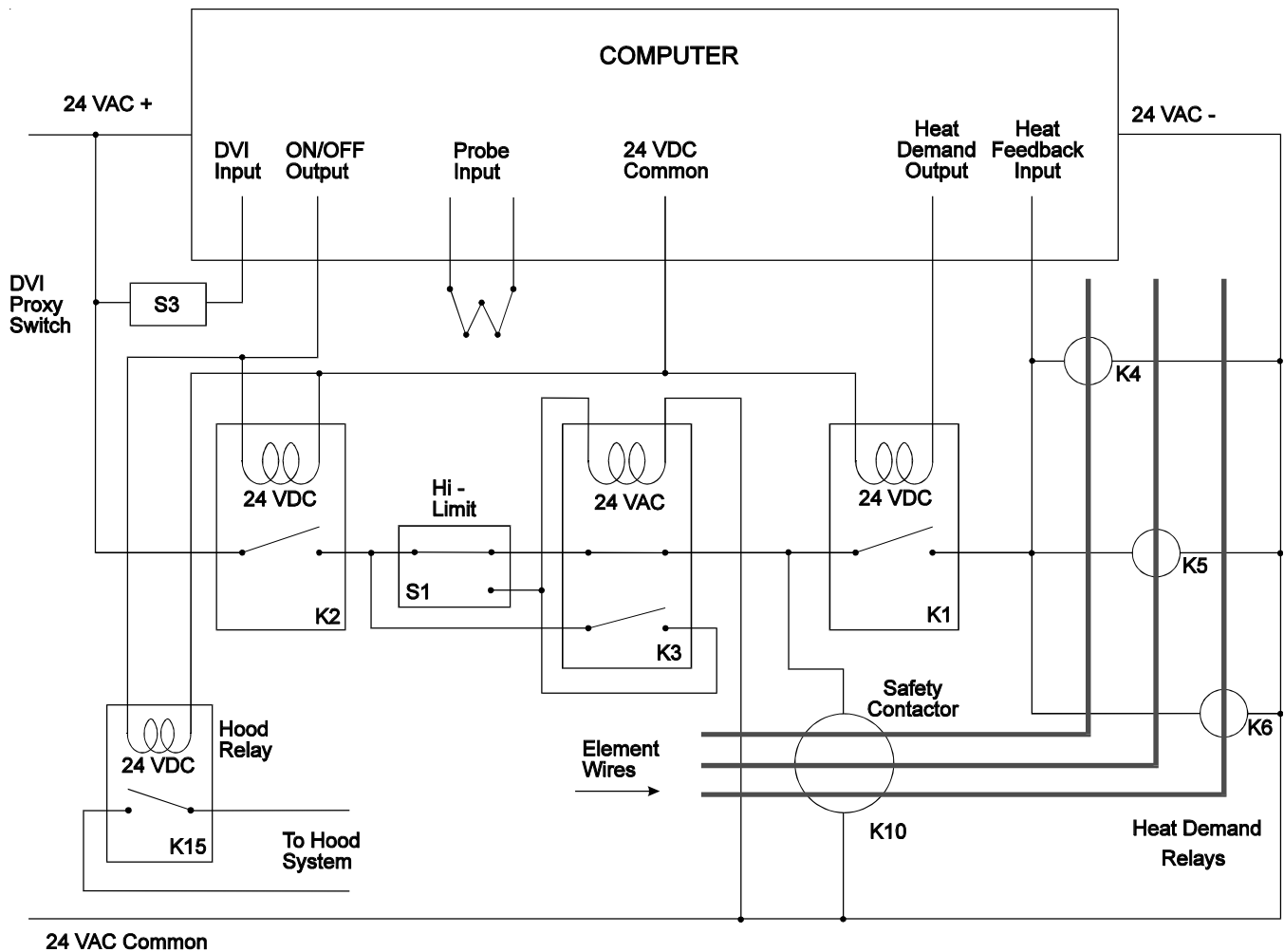

Filter System:

Opening the RED Return Valve Handle will cause the Pump On Relay to be energized and the pump will begin to pump. Closing the Return Valve Handle will de - energize the Relay and the Pump will stop pumping.

Hood Relay System:

There is one Hood Relay (K15) per "battery" of fryers, it is wired in parallel to every computer (both sides of a split vat). When any side of any computer is turned ON this Relay (K15) will energize and will stay energized until all of the computers are turned OFF.

Chapter 2: COMPONENT TROUBLESHOOTING:

Probe:

The resistance of the probe will change as the temperature changes. The resistance will decrease as the temperature rises. The lower the temperature the greater the resistance change will be per degree of temperature change, as the temperature approaches the working range of the probe, the resistance change will become more linear.

If the probe is suspect, check its resistance and the oil/air temperature at which it was taken. Compare these values on the chart below.

TEMP °F	RESISTANCE Ohms	TEMP °F	RESISTANCE Ohms
60	139055	330	1192
80	84644	335	1123
100	53146	340	1058
120	34328	345	998
140	22755	350	942
160	15446	355	890
180	10716	360	841
200	7586	365	795
210	6427	370	752
220	5470	375	712
240	4013	380	675
260	2991	385	640
280	2262	390	607
300	1734	395	576
320	1347	400	547
325	1267		

If the probe returns an open circuit or 0 Ohms reading it should be replaced. If the resistance varies more than 20 Ohms when being checked between 325-375°F the probe will give a false temperature reading on the computer and should be replaced. However, it will continue to operate at a slightly higher or lower temperature. Allow the oil to cool and check the probe resistance at a lower temperature. As can be seen from the chart a greater degree of offset can be allowed at a lower temperature.

Relays:

The Heat Demand and Hood relays are 24VDC relays and will energize when the correct voltage is supplied to the coil. When energizing, the relay Switching Contacts will close, thus connecting the Common and Normally Open terminals. The Hi - Limit relay is a 24VAC relay and may be checked in the same manner as the above relay.

Hi Limits:

A Hi - Limit switch is a normally closed switch until the temperature at the probe reaches $435 \pm 15^{\circ}\text{F}$. In order to test this switch it will be necessary to bypass the Heat Demand Relay. Refer to Page 7 of the Operating Manual for instructions on how to perform this test.

WARNING

Do NOT leave the machine during this test. This test will cause the oil to heat past the normal operating temperature and can cause damage to the machine and its operator.

If the switch does not trip between the prescribed limits it is defective and should be replaced. Once tripped, the switch will not reset until the oil has cooled to approximately 400°F . If the switch does not reset it is defective.

Drain Valve & Return Valve Switches:

This switch is a magnetically operated Reed switch. When the Drain Valve handle is moved to the open position, the Actuator will move away from the switch causing the Reed switch to open. When the Drain Valve is closed the Reed switch will close. This switch can also be checked with an Ohm meter. The normal gap between the Actuator and the Sensor switch on the Drain Valve handle is $\frac{1}{8}'' - \frac{1}{4}''$ (3 - 6mm).

Transformer:

Transformers are multiple input voltage 24 volt output voltage and can be checked by reading the input and output voltages.

Elements:

Each Element has three coils inside it, check all element coils with an Ohm Meter, the resistance should correspond to the chart below, if the resistance varies more than 5 Ohm the element will need to be changed. Also check for continuity to ground on each end of the suspect element, there should be no continuity to ground.

208 volt elements	18.5 Ohms
220 volt elements	20.7 Ohms
240 volt elements	24.6 Ohms

Contactor:

Check the coil with an Ohm Meter, the resistance should be approximately (400 Ohms), if it does not have this resistance it should be changed.

Chapter 3: TROUBLESHOOTING GUIDE

Fryers:

PROBLEM	POSSIBLE CAUSE	ACTION
Computer will NOT turn ON Display does NOT light	A. No power to the machine B. F1 Fuse is blown C. T1 Transformer	A. Check building circuit breaker Check power cord is plugged in B. Check Fuse F1.replace if defective C. Check voltage In & Out of TI
Computer comes ON, Hood system does NOT	A. Hood relay	A. Check & replace if defective
Computer shows "IGNITION" "FAILURE" and machine does NOT heat	A. Hi Limit tripped B. Safety contactor C. Heat Demand relay D. Hi Limit relay E. Power On relay F. Heat Demand relay G. Elements	A. If oil is below 400°F, reset Hi Limit replace if defective. If oil is above 400°F, allow to cool and try to reset B. Check & replace if defective C. Check & replace if defective D. Check & replace if defective E. Check & replace if defective F. Check & replace if defective G. Check & replace if defective
Machine is heating slowly	A. Heat Demand relay B. Element C. Loss of power on 1 leg of 3 Phase input power	A. Check & replace if defective B. Check & replace if defective C. Check input power, repair or call Authorized Electrician
Oil is Colder or Hotter than computer/controller registers	A. Probe B. Probe wiring terminals	A. Check & replace if defective B. Clean or repair
Computer display shows "DRAINING" or "TURN OFF"	A. Green Drain valve not fully closed B. Sensor switch C. Incorrect switch gap	A. Check position of handle B. Switch may be loose or have loose wires C. Check gap, replace if defective
Elements do not stay down or seem to float or are stuck in up position	A. Spring tension B. Lock handle may be stiff or seized	A. Check & adjust B. Loosen & lubricate

Filters:

PROBLEM	PROBABLE CAUSE	CORRECTIVE ACTION
Red Return Valve is open but no pump sound can be heard	<ul style="list-style-type: none"> A. Red Return Valve NOT fully open B. Filter Circuit Breaker may be tripped C. Filter Motor Thermal Overload may be tripped D. Sensor switch may be loose or defective 	<ul style="list-style-type: none"> A. Pull slightly on the Red handle to check that it is fully open. B. Locate the circuit breaker and reset. C. Push Red reset button located on end of filter motor. D. Check that the switch is tight in its mounting. If switch is bad replace it.
Drain valve is closed and the computer has been reset but still shows "DRAINING" or "TURN OFF"	<ul style="list-style-type: none"> A. Green Drain Valve is NOT fully Closed B. Sensor switch may be loose or bad 	<ul style="list-style-type: none"> A. Apply a little more pressure to the Green Handle to check that it is fully closed. B. Check that the switch is tight in its mounting. If switch is bad replace it.
Drain Valve is OPEN, the oil is draining slowly or not at all.	<ul style="list-style-type: none"> A. Green Drain Valve is NOT fully open B. Drain is plugged with debris 	<ul style="list-style-type: none"> A. Apply a little more pressure to the Green Handle to check that it is fully open. B. Use the Clean Out Rod from inside the Fry Vat to clear the Drain Valve. If this does NOT clear the blockage, CLOSE the Green Drain Valve and follow these instructions for clearing the main drain line. <p style="text-align: center; margin: 10px 0;">CAUTION:</p> <p>Some HOT oil may still come out when the cap is removed. Remove the two screw from the end cap (Do NOT lose these.) Use the Clean Out Rod to clear the main drain tube. Install the end cap along with its gasket and two screws. Do not overtighten these screws.</p>

Chapter 3: COMPONENT CHANGEOUT:

Probe:

1. Remove the rear housing cover.

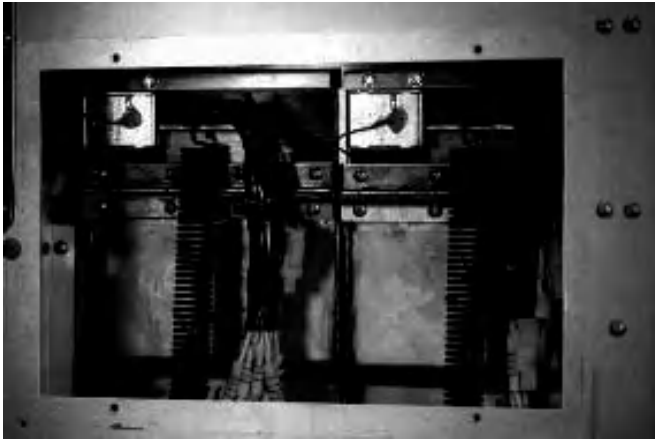

2. Disconnect the wiring connector.
3. Push the pins/sockets out of the connector.
4. Remove the 2 probe brackets.

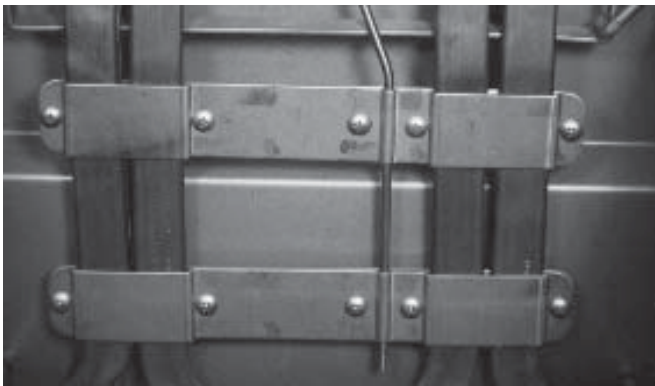

5. Pull the probe down through the rubber grommet.

Install in the reverse order.

Hi Limit:

1. Remove the rear housing.
2. Remove the 2 mounting screws.



3. Disconnect the 2 wires from the connections on the Hi Limit.
 4. Remove the 2 probe brackets.
 5. Remove the Hi Limit Bulb bracket.
 6. Gently remove the rubber grommet from around the capillary of the Hi Limit.
 7. Pull the Hi Limit up through the hole.
- Install in the reverse order.

Elements:

1. Remove the rear housing.
2. Remove the 2 probe brackets.
3. Remove the Hi Limit Bulb bracket.
4. Remove the element rack.
5. Using a suitable cutting tool, cut the appropriate wires at the yellow crimped connections.
6. Pivot the elements up so that the mounting screws are exposed, remove the 2 mounting screws.



7. Pull the element out of the pivot assembly and feed the wires through the hole.

Install in the reverse order.

Components mounted in the front panel:

To access all of the components mounted in the front panel, remove the 2 screws at the top of the computer/controller.

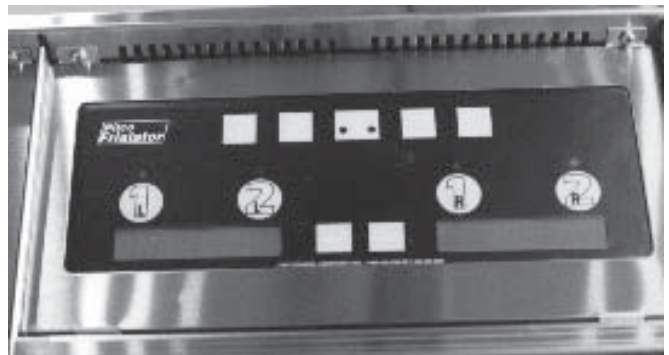

Pivot the front panel down and allow the computer to be supported on the mounting tabs.



Unplug the computer/controller wiring harness. The front panel can now be removed by pulling the complete assembly forward.

Remove the lower cover by removing the 2 screws located in the bottom of the cover.



All of the components mounted in the front panel can now be accessed through the opening.

Heat Demand Relays:

Mounted on the rear brace of each fryer unit you will find the Heat Demand Relay housing. Remove the cover of the housing from the front of the machine. The Relays can now be seen from the front, they are mounted to the Heat Sink using 2 screws. Terminals 1 & 2 are the load connections and terminals 3 & 4 are the 24VAC input terminals.

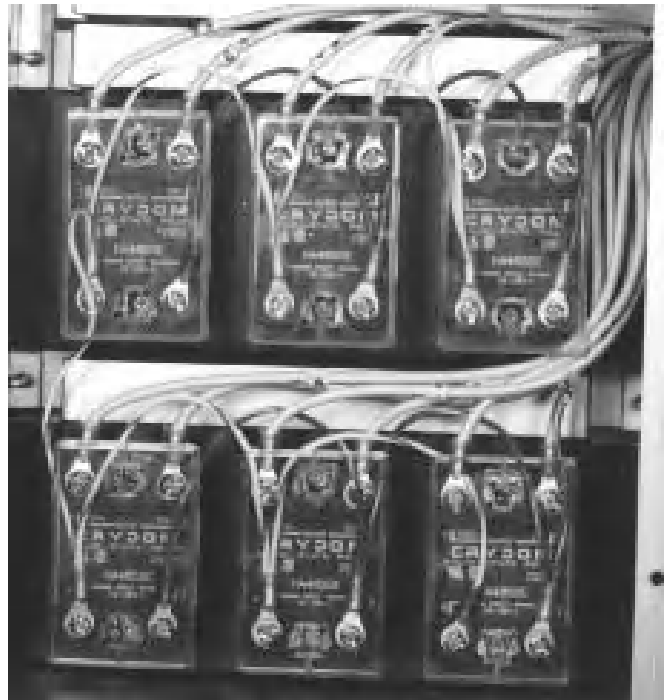

Circuit Breaker:

Remove the mounting screws on either side of the cover. Turn the cover over and the circuit breaker can be removed from the cover.

Hood & Filter Relays:



These relays are always wired in the following manner -

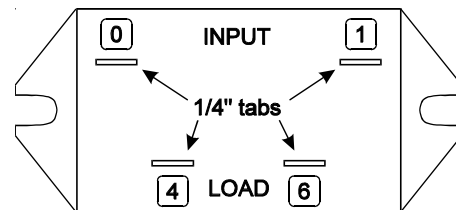

Control Relays:

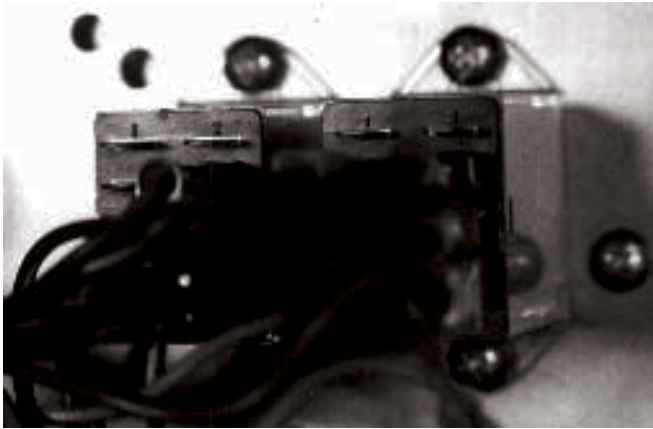

Control relays are always wired in the following manner -

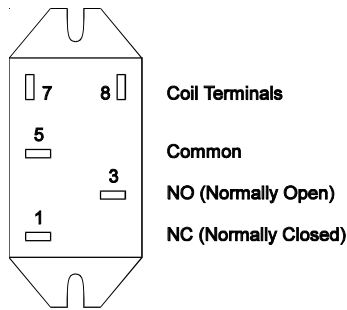

Proximity Switches:

1. The actuator can be removed by removing the 2 mounting screws.



2. The sensor may be removed by disconnecting

the wiring harness and by removing the 2 mounting screws.

Install in the reverse order.

Filter Pumps:

1. From the front of the machine, pull the ring back on each of the 2 quick disconnects and release the couplings.

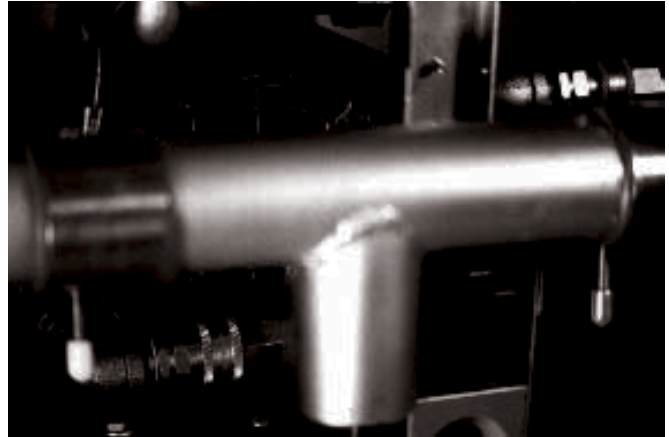

2. Remove the 2 screws, and the front of the Pump/Motor assembly will drop. The assembly can be removed from the machine by lifting the rear slightly and pushing back. The front of the mount can be lowered until the assembly can be removed from the machine.



Install in the reverse order.

PARTS SECTION

ME14 FRYER SOLID STATE RELAY PARTS LISTS

I.D. #	PART #	PART DESCRIPTION
1	PP10693	10-24 X 3/8 SCREW
2	A1844801	FULL VAT RELAY COVER
	A1844901	SPLIT VAT RELAY COVER
3	PP10752	10-32 X 1/2 SCREW
4	A1844501	FULL VAT RELAY BACK COVER
	A1844601	SPLIT VAT RELAY BACK COVER
5	B5303201	RELAY WITH HEAT SINK
6	P6071220	GROMMET
7	B6746902	FULL VAT HI-POWER RELAY HARNESS
	B6746901	SPLIT VAT HI-POWER RELAY HARNESS
8	A1845201	RELAY GUARD (NOT SHOWN)
9	B5308501-C	COMPLETE FULL VAT RELAY ASSEM.
	B5308601-C	COMPLETE SPLIT VAT RELAY ASSEM.

ME14 SOLID STATE RELAY

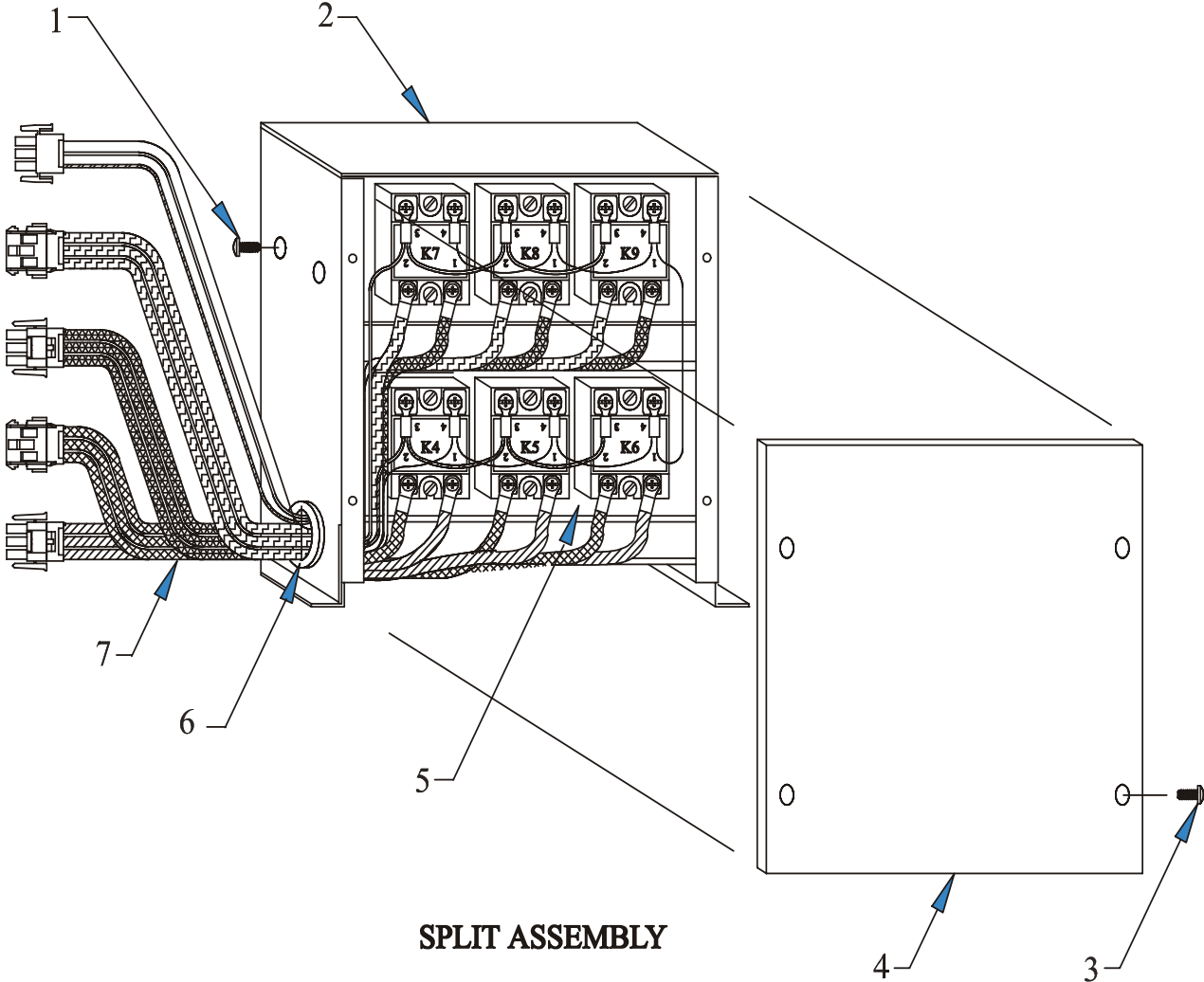

SPLIT ASSEMBLY

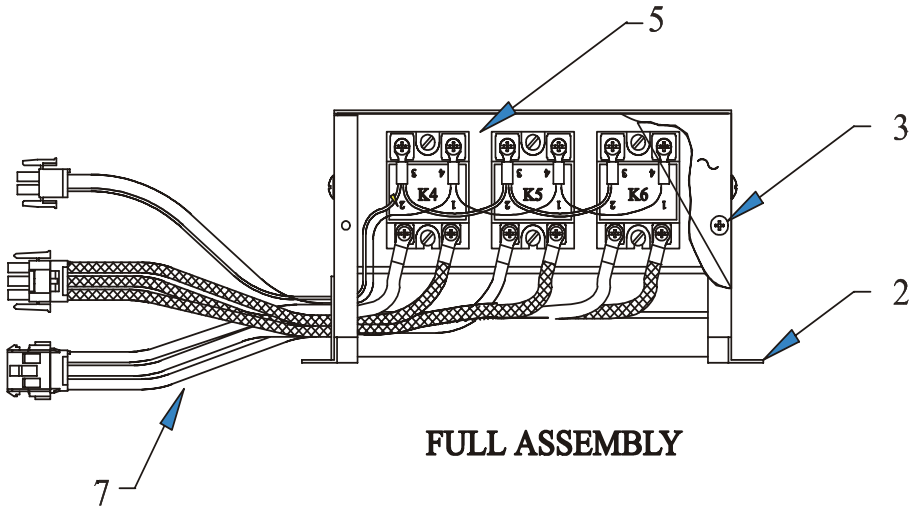

FULL ASSEMBLY

ME14 FRYER CABINET

PARTS LISTS

I.D. #	PART #	PART DESCRIPTION
1	PP10752	10-32 X 1/2" SCREW
2(For fryers without capping piece)	A5055502	DUAL SPLASH BACK SEAL ANGLE
	A5055504	TRIPLE SPLASH BACK SEAL ANGLE
	A5055506	QUAD SPLASH BACK SEAL ANGLE
	A5055508	QUINT SPLASH BACK SEAL ANGLE
	A5055510	SINGLE SPLASH BACK SEAL ANGLE
3	B2607801	SINGLE PIVOT BOX HOUSING
	B2607802	DUAL PIVOT BOX HOUSING
	B2607803	TRIPLE PIVOT BOX HOUSING
	B2607804	QUAD PIVOT BOX HOUSING
	B2607805	QUINT PIVOT BOX HOUSING
	B2607806	CE SINGLE PIVOT BOX HOUSING
	B2607807	CE DUAL PIVOT BOX HOUSING
	B2607808	CE TRIPLE PIVOT BOX HOUSING
	B2607809	CE QUAD PIVOT BOX HOUSING
	B2607810	CE QUINT PIVOT BOX HOUSING
4	A1625901	ALUMINIZED CAB BACK COVER
	A1625902	STAINLESS STEEL CAB BACK COVER
5	A1843901	ALUMINIZED GREASE SHEILD
	A1843902	STAINLESS STEEL GREASE SHEILD
6	A1629101	SINGLE CABINET BACK
	A1629102	STAINLESS STEEL SINGLE CAB BACK
	A1629201	DUAL CABINET BACK
	A1629202	STAINLESS STEEL DUAL CAB BACK
	A1629301	TRIPLE CABINET BACK
	A1629302	STAINLESS STEEL TRIPLE CAB BACK
	USE DUAL TWICE	QUAD FRYER CABINET BACK
	USE DUAL & TRIPLE	QUINT FRYER CABINET BACK
7	P0020600	1/4-20 X5/8" BOLT
8	PP10814	9" NON LOCKING CASTERS
	PP10815	9" LOCKING CASTER
9	P0093300	1/4-20 NUT
10	B3622401	SINGLE FRONT PANEL TOP DECK
	B3627001	DUAL FRONT PANEL TOP DECK
	B3627201	TRIPLE FRONT PANEL TOP DECK
	B3627401	QUAD FRONT PANEL TOP DECK
	B3628201	QUINT FRONT PANEL TOP DECK
11	P0080650	1/4" FLAT WASHER
12	B2302301	LEFT HAND DOOR
	B2302302	RIGHT HAND DOOR

ME14 FRYER CABINET DRAWING

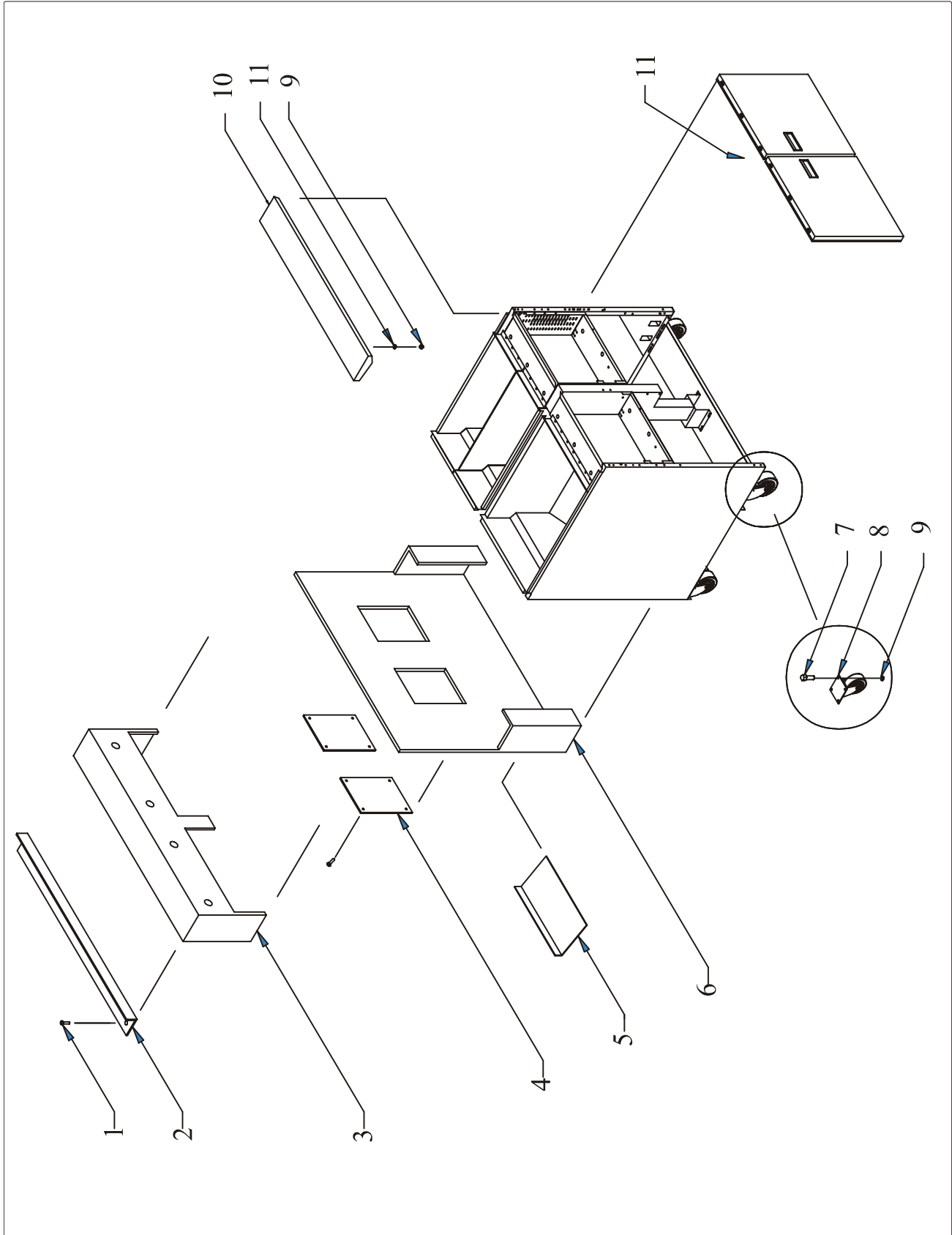

ME14 FRYER ELEMENTS PARTS LISTS

I.D. #	PART #	PART DESCRIPTION
1	B2800901	FULL VAT ELEMENT RACK
	B2800902	SPLIT VAT ELEMENT RACK
2	PP11116	6-32 X .440" SCREW
	60127001	#6 INTERNAL STAR LOCK WASHER
3	A1404102	FULL VAT ELEMENT & PROBE CLAMP
	A1404002	SPLIT VAT ELEMENT & PROBE CLAMP
4	PP10954	10-32 X 1/2" SCREW
5	PP11010	HI-LIMIT BULB
6	A1404402	HI-LIMIT BULB BRACKET
7	PP11007	208 VOLT ELEMENT
	PP11008	220 VOLT ELEMENT
	PP11009	240 VOLT ELEMENT
8	PP11018	ME TEMPERATURE PROBE
9	A2807002	ELEMENT RACK CLIP
10	A1404302	FULL VAT REAR ELEMENT CLAMP
	A1404202	SPLIT VAT REAR ELEMENT CLAMP

ME14 FRYER ELEMENTS

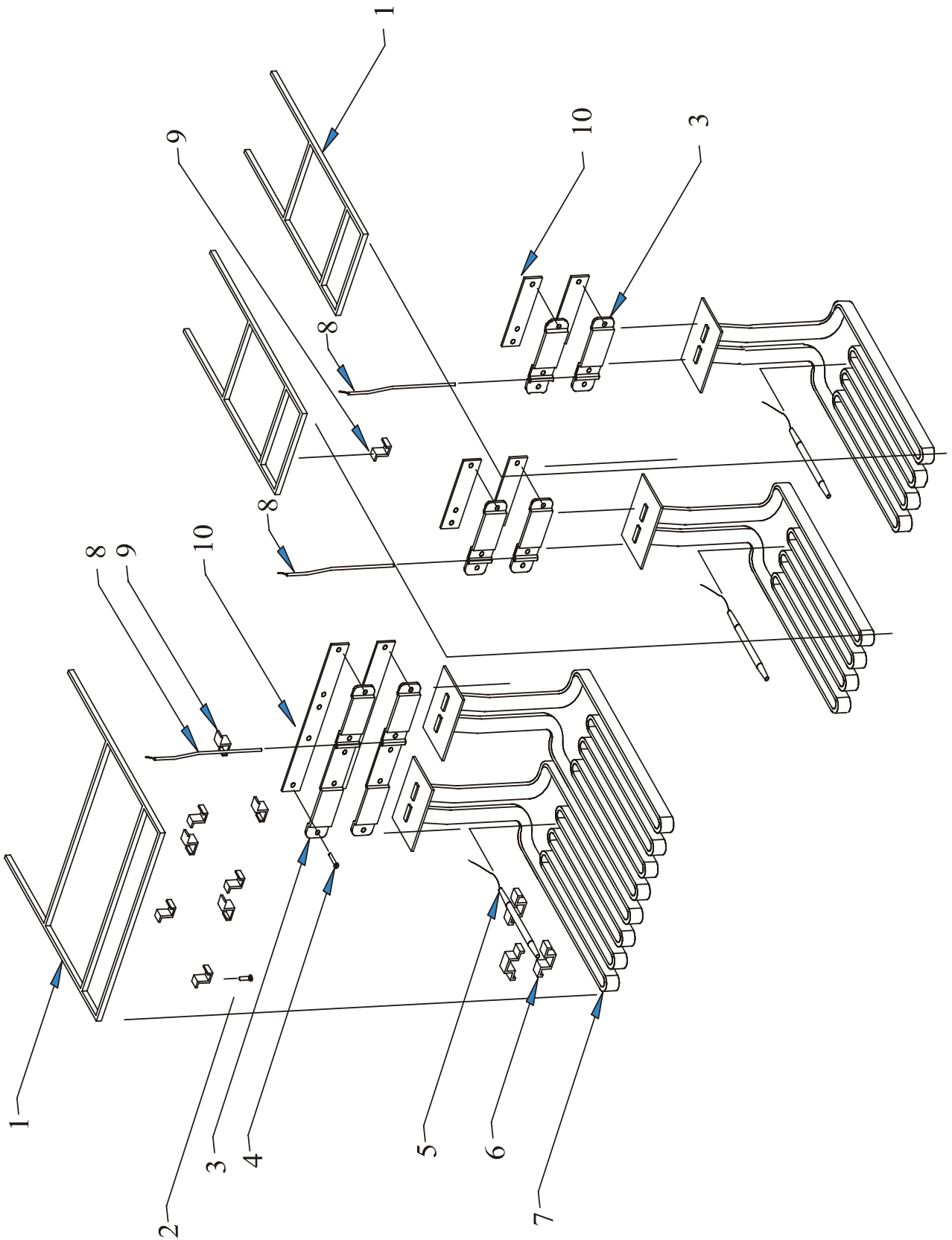

ME14 FRYER FILTER DRAWER PARTS LISTS

I.D. #	PART #	PART DESCRIPTION
1	B6640901-C	PAPER RETAINING RACK
2	B6647701-C	OIL DRAIN CATCH TOWER
3	PP10409	FILTER COUPLING "O" RING
4	B6661601	FILTER PICK-UP INSERT
5	P0020900	1/4-20 HEX HEAD SCREW
	P6071020	1/4" NYLON BUSHING
	P0080650	1/4" FLAT WASHER
	P0093300	1/4-20 NUT
6	PP10177	VINYL PROTECTIVE COVER
	P0093300	1/4-20 NUT
	P0080650	1/4" FLAT WASHER
	P0020900	1/4-20 HEX HEAD SCREW
7	B6640701-C	FILTER DRAWER HANDLE
8	B6640601-C	FILTER DRAWER WELDMENT
9	PP11152	ROLLER WHEEL KIT
10	B6656801-C	FILTER DRAWER EXTENSION RAIL (RH)
	B6656802-C	FILTER DRAWER EXTENSION RAIL (LH)
11	A7008302	PAPER SUPPORT RACK
12	B6661501-C	FILTER PAN
13	P0007300	8-32 X 1/4" SCREW
14	PP10900	FLAT WASHER
15	B6641001-C	FRONT FILTER PAN COVER W/HANDLE
	A7001102	FRONT FILTER PAN COVER NO HANDLE
16	P6071516	FILTER PAN COVER HANDLE
17	A7013502	REAR FILTER PAN COVER
18	B6640801	FILTER DRAWER ASSY. (INCLUDES 5-9)
19	B6645701	FILTER PAN ASSY. (INCLUDES 1-17)

ME14 FRYER FILTER DRAWER

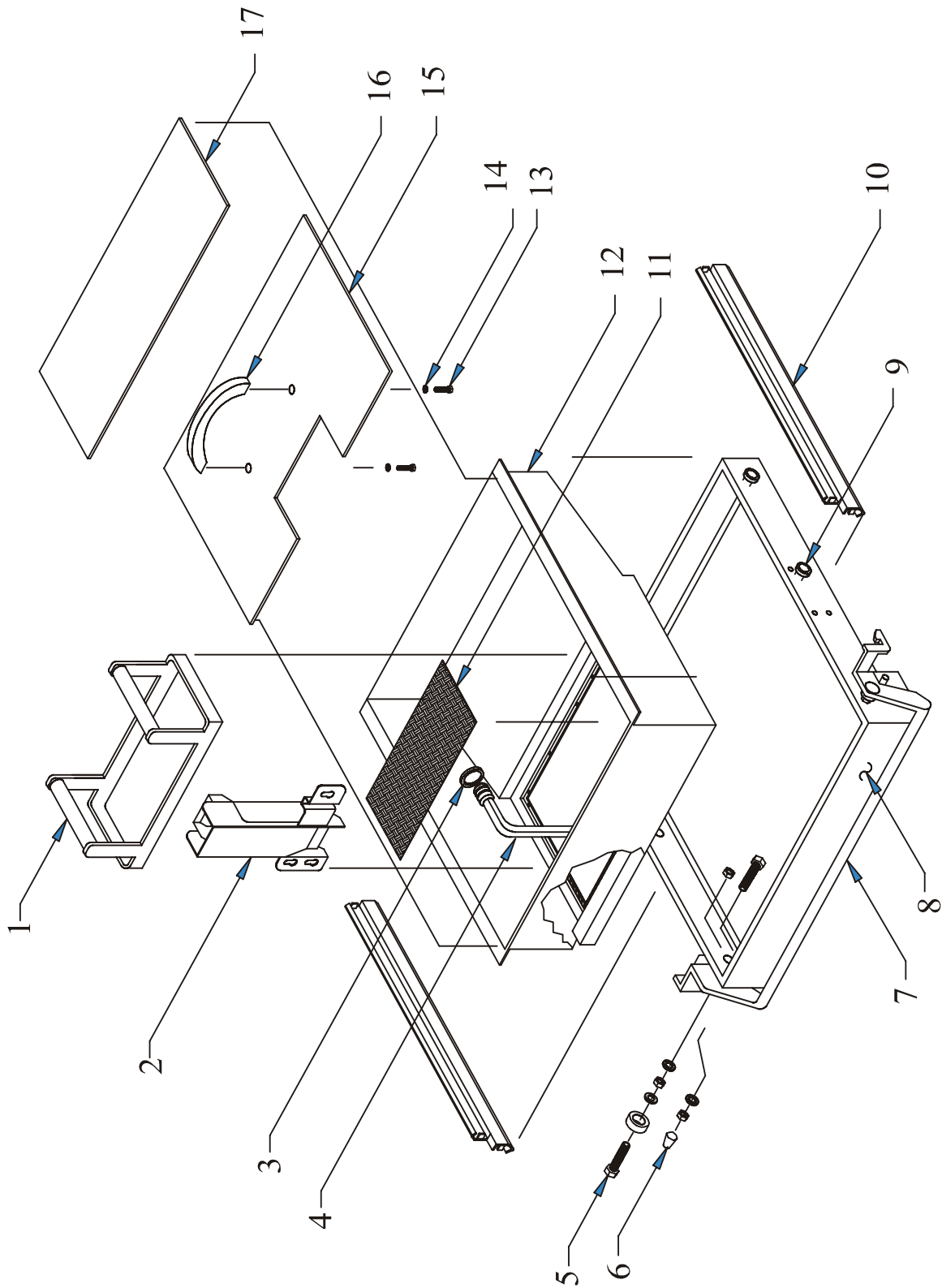

ME14 FRYER PIVOT BOX (REAR) PARTS ASSEMBLY

I.D. #	PART #	PART DESCRIPTION
1	PP11164	ELEMENT SENSOR SWITCH
2	PP10266	4-40 X 1/4" SCREW
3	A2607702	ELEMENT SENSOR BRACKET
4	P0075400	10-24 X 1/2" SCREW
5	A2609401	PIVOT BOX ANCHOR BEARING
6	P0190100	CLEAVIS PIN
7	A2609201	PIVOT BOX LINKAGE BAR
8	PP11310	CLEAVIS PIN
9	P0190300	COTTER PIN
10	A2608901	PIVOT BOX STOP BRACKET
11	PP11010	HI-LIMIT SWITCH
12	PP11045	FULL VAT HINGE WITH HOLES
	PP11046	SPLIT VAT HINGE WITH HOLES
13	A2608401	WIRE RETAINER
14	PP11310	HI-LIMIT WIRE HARNESS(NOT SHOWN)
15	B2607201	FULL VAT SUPPORT BRACKET
	B2607501	SPLIT VAT SUPPORT BRACKET

ME14 PIVOT BOX REAR

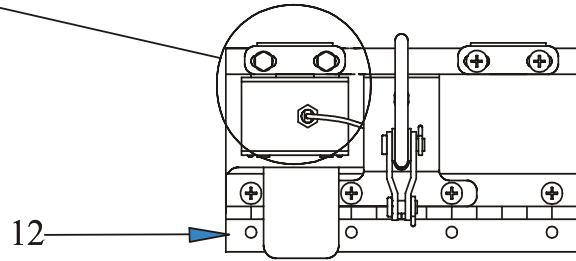
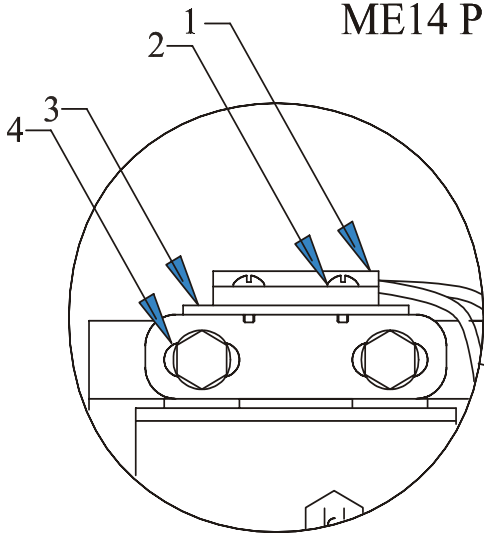

SPLIT TANK PIVOT BOX REAR VIEW

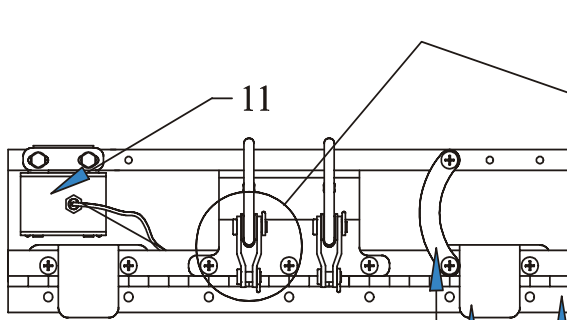

FULL TANK PIVOT BOX REAR VIEW

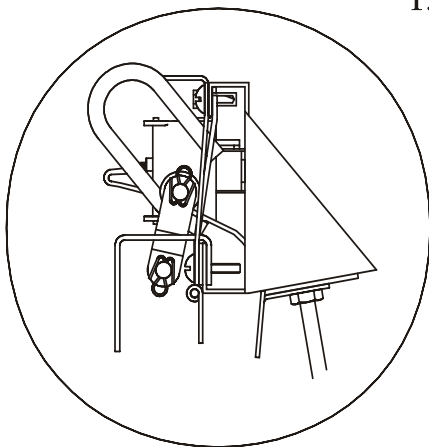
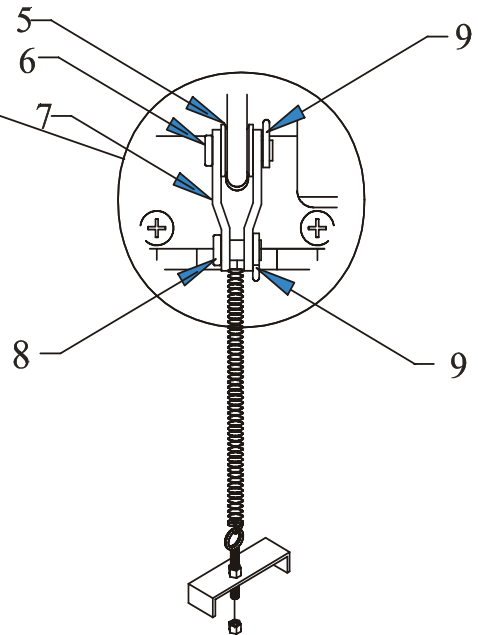

SIDE VIEW FULL AND SPLIT TANK

MG14 FRYER DRAIN VALVE HANDLE PARTS ASSEMBLY

I.D. #	PART #	PART DESCRIPTION
1	PP11302	VINYLDRAIN VALVE HANDLE COVER
2	PP10263	DRAIN PROXIMITY SWITCH ACTUATOR
3	B4002902-C	DRAIN VALVE HANDLE FULL, RH SPLIT
	B4002901-C	DRAIN VALVE HANDLE LH SPLIT VAT
4	PP10266	4-40 X 1/4" SCREW
5	PP10647	1/2-13 NUT
6	PP11059	PLUNGER ASSEMBLY
7	A4015801	DRAIN HANDLE RELEASE LEVER
8	PP11303	RELEASE LEVER VINYL COVER
9	B4003001-C	FULL VAT HANDLE ASSEMBLY
(Complete drain valve handle assy)	B4003003-C	LH SPLIT VAT HANDLE ASSEMBLY
	B4003005-C	RH SPLIT VAT HANDLE ASSEMBLY

ME14 FRYER DRAIN VALVE HANDLE PARTS DRAWING

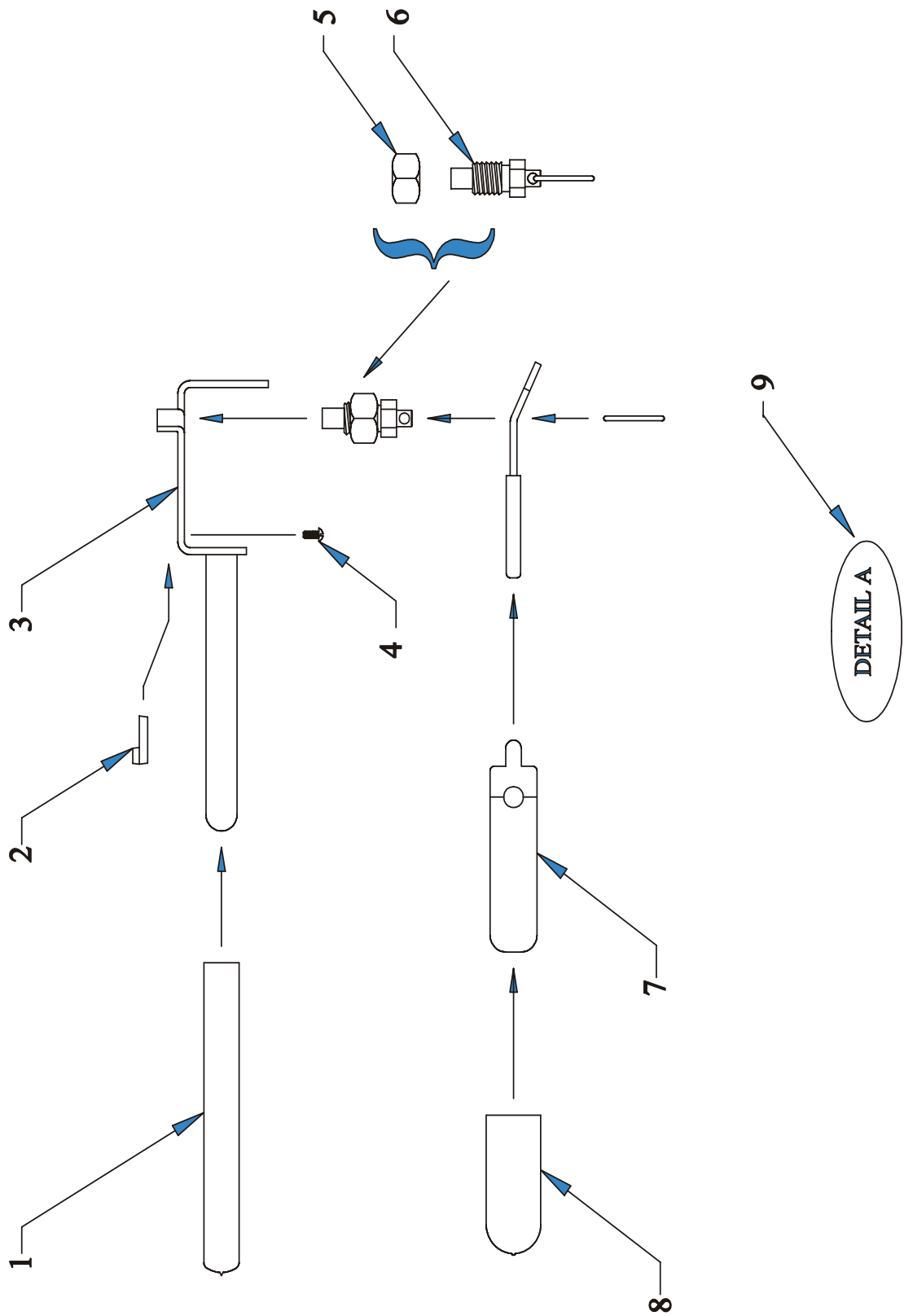

ME14 DRAIN LINE AND PUMP PARTS LISTS

I.D. #	PART #	PART DESCRIPTION
1	P0079500	10-24 X 1/2" THUMB SCREW
2	A7004401	CLEANOUT COVER
3	PP11182	CLEANOUT COVER GASKET
4	PP10568	#10-24 WING NUT
5	B6643101	DRAIN CAP END
6	PP11181	DRAIN CAP GASKET
7	PP10696	10-24 X 1 1/4" SCREW
8	P6071769	SPLIT VAT DRAIN VALVE
	PP10368	FULL VAT DRAIN VALVE
9	B6638301	FULL/FULL FILTER DRAIN
	B6638302	FULL/SPLIT FILTER DRAIN
	B6638501	SPLIT/SPLIT FILTER DRAIN
10	PP11202	DRAIN LINE GASKET
	PP11172	DRAIN LINE BAND CLAMP
11	A6699601	CENTER SPLIT DRAIN TUBING SPACER
	A6699607	SPLIT/SPLIT DRAIN TUBING SPACER
	A6699603	FULL/SPLIT DRAIN TUBING SPACER
	A6699605	FULL/FULL DRAIN TUBING SPACER
12	B6653101	SPLIT VAT RH DRAIN TEE
	B6653001	SPLIT VAT LH DRAIN TEE
	B6643506	SPLIT VAT CENTER DRAIN TEE
	B6643303	FULL VAT LH DRAIN TEE
	B6643203	FULL VAT RH DRAIN TEE
	B6643504	FULL VAT CENTER DRAIN TEE
13	A7011901	FILTER RETURN RECIEVING BLOCK
14	PP11241	18" FLEXIBLE RETURN LINE
	PP11242	20" FLEXIBLE RETURN LINE
15	PP10101	115/220/230V 50/60HZ PUMP AND MOTOR
	PP10171	240V 50HZ PUMP AND MOTOR
	PP10417	PUMP ONLY
	PP10416	115/220/230V 50/60HZ MOTOR ONLY
16	P0020600	1/4-20 X 5/8" BOLT
	P0080650	1/4" WASHER
17	B6638801	PUMP PLATE
18	PP10039	HEAT TAPE, 165W 110V 1/2" X 79"
	PP10080	HEAT TAPE, 165W 240V 1/2" X 79"
	PP10976	HEAT TAPE, 96W 110V 1/2" X 48"
	PP10588	HEAT TAPE, 96W 240V 1/2" X 48"
19	B4002003	FULL/RH SPLIT RETURN VALVE HANDLE
	B4002004	LH SPLIT RETURN VALVE HANDLE

ME14 DRAIN LINE AND PUMP

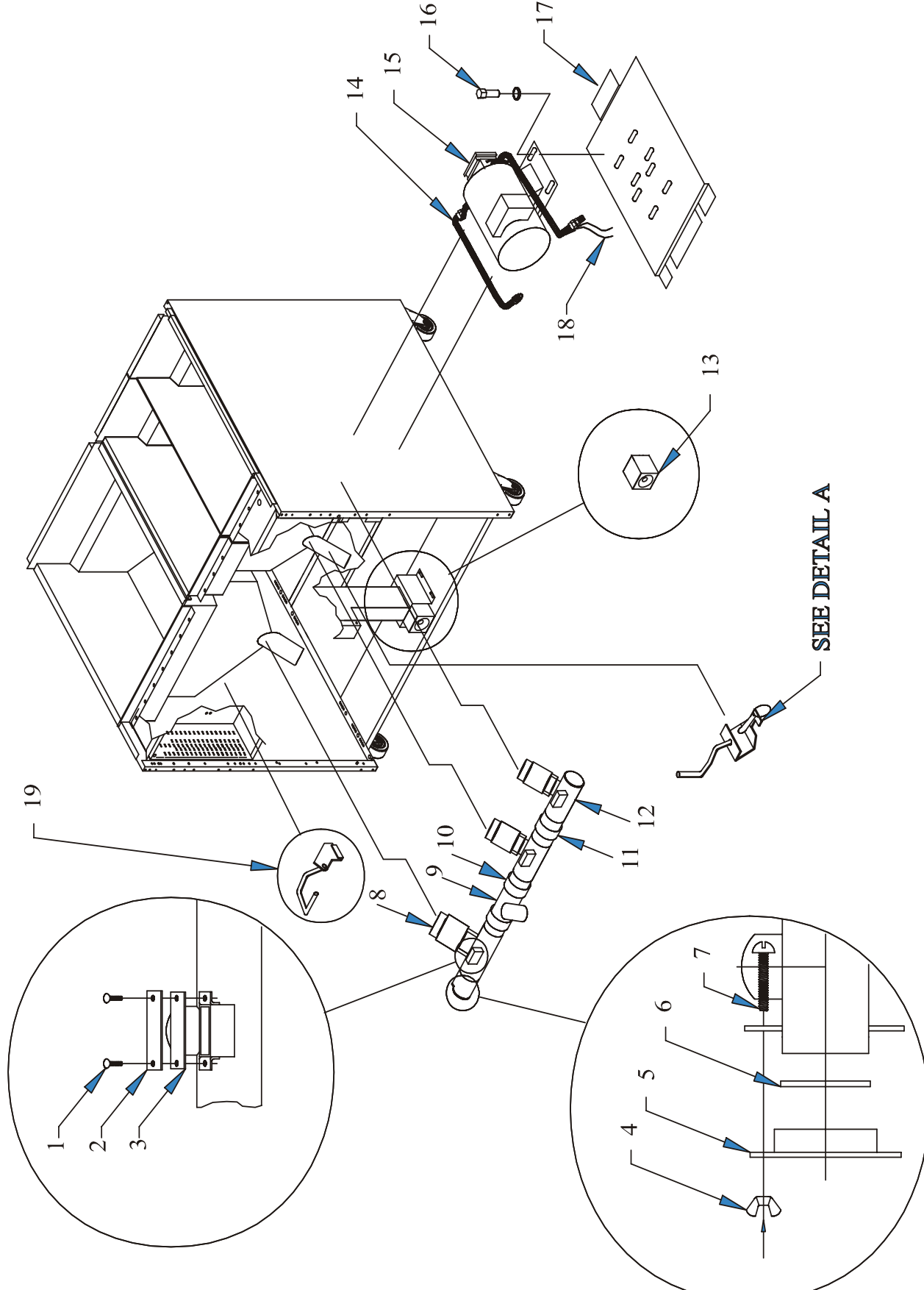

ME14 FRYER ACCESSORIES

PARTS LISTS

I.D. #	PART #	PART DESCRIPTION
1	B5002701	DUAL ELECTRIC CAPPING PIECE
	B5002702	TRIPLE ELECTRIC CAPPING PIECE
	B5002703	QUAD ELECTRIC CAPPING PIECE

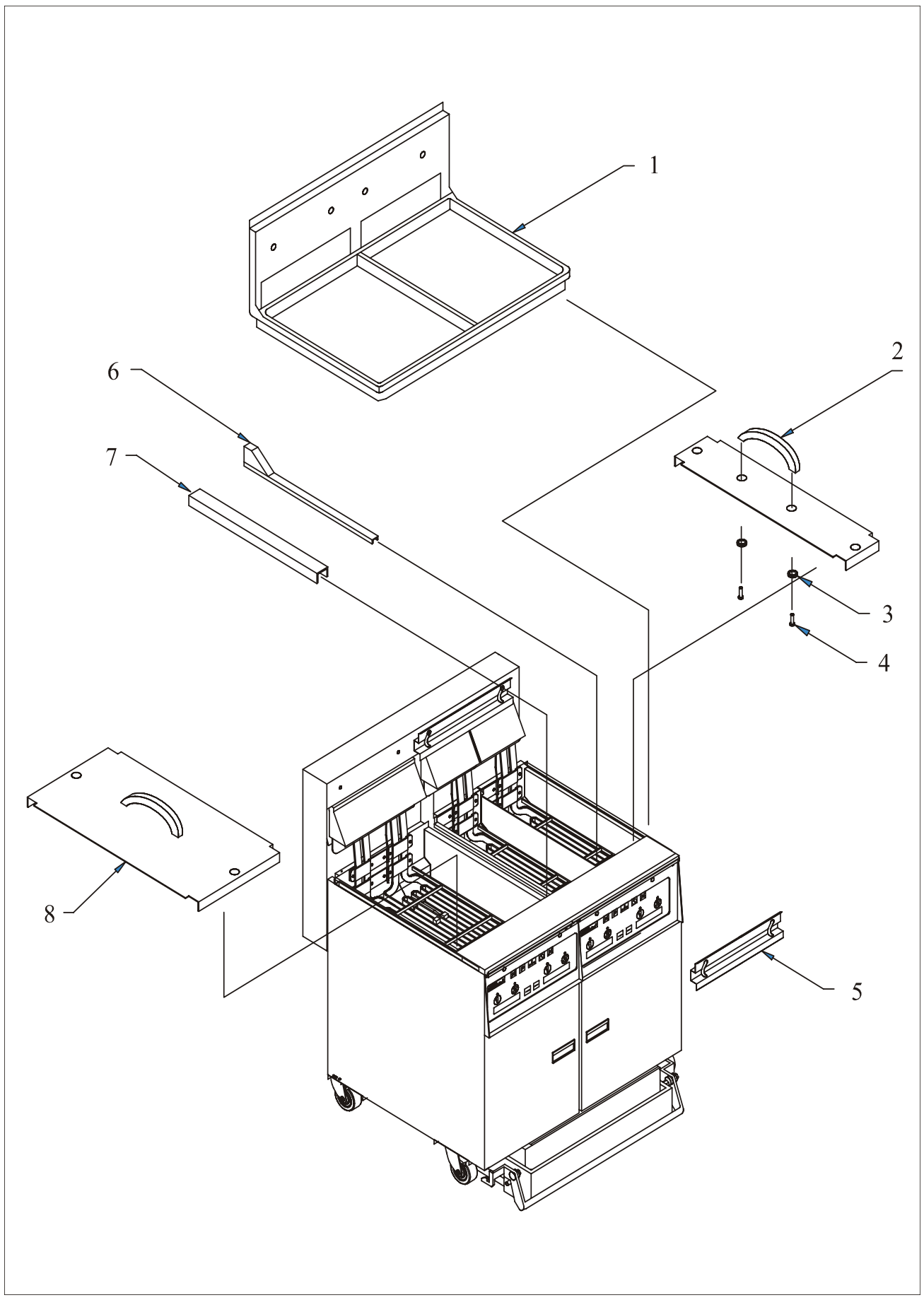

ME14 SCHEMATIC 700246H

PARTS LIST

NOMENCLATURE	PART NO.	DESCRIPTION
A1	PP11374	COMPUTER, EP3620-14 MLB McD
CB1	PP10460	SW, CIRCUIT BREAKER SPST 8.0A 250V
	PP10470	SW, CIRCUIT BREAKER DPST 4.0A 250V
D1,D2	PP11050	DIODE, 400V 1A
DSI	PP10331	LAMP, 125V GREEN RECT
	PP10736	LAMP, 250V GREEN RECT
F1	P5045720	FUSE, 4A SLOW BLOW GLASS
	PP11007	ELEM, FLAT BAR W/BRKT 7KW 208V 3PH
HR1,HR2,HR3	PP11008	ELEM, FLAT BAR W/BRKT 7KW 220V 3PH
	PP11009	ELEM, FLAT BAR W/BRKT 7KW 240V 3PH
	PP10039	HEATER, TAPE 165W 110V 1/2 X 79
	PP10194	HEATER, TAPE 96W 110V 1/2 X 48
HR4	PP10080	HEATER, TAPE 165W 240V 1/2 X 79
	PP10588	HEATER, TAPE 96W 240V 1/2 X 48
J1,J2	PP10209	CONNECTOR, JACK 12 SOCKET AMP
J3	PP10203	CONNECTOR, JACK 4 SOCKET AMP
J4,J12,J13,J14 J15,J16,J17,J18 J19,J20,J24 J25,J35	P5045839	CONNECTOR, JACK 2 SOCKET AMP
J22,J23,J35	PP10089	CONNECTOR, JACK 3 SOCKET AMP
J26,J30	PP11341	CONNECTOR, JACK 3 SOCKET AMP (HIGH CURRENT)
J31,J32,J33,J34 J27,J28,J29	60122702	CONNECTOR, JACK 4 SOCKET AMP (HIGH CURRENT)
K1,K2,K11,K12	P5046690	RELAY, 24VDC SPST
K3,K13	P5046687	RELAY, 24VAC DPDT
K10,K14	PP10560	CONTACTOR, 24VAC-3 POLE QUICK CONNECT
K4,K5,K6 K7,K8,K9	PP11011	RELAY, SOLID STATE 24VAC 50A SPST
K15	PP11033	RELAY, SPST 30A 24VDC
K16	PP11058	RELAY, SPST 30A 24VAC
M1	PP10101	PUMP/MTR-1/3 HP 115/230V
M2	PP10171	PUMP/MTR-1/3 HP 240V
P1,P2	PP10208	CONNECTOR, PLUG 12 PIN AMP
P3	PP10202	CONNECTOR, PLUG 4 PIN AMP
P4,P12,P13,P14 P15,P16,P17,P18 P21,P24,P25,P35	P5045829	CONNECTOR, PLUG 2 PIN AMP
P22,P23,P35	PP10090	CONNECTOR PLUG 3 PIN AMP
P26,P30,P31 P32,P33,P34	PP11342	CONNECTOR, PLUG 3 PIN AMP (HIGH CURRENT)
P26,P30,P31 P32,P33,P34	PP11342	CONNECTOR, PLUG 3 PIN AMP (HIGH CURRENT)
P27,P28,P29	60122701	CONNECTOR, PLUG 4 PIN AMP (HIGH CURRENT)
RT1,RT2	PP11018	PROBE, THERMISTOR ELEC.
S1,S2	PP11010	SW, HI LIMIT LCC 435F-30"
S3,S4,S5,S6	PP10262	SW, PROXIMITY SENSOR
S7	PP10739	TSTAT, SNAPDISK 135F-OPEN, 105F-CLOSE
	PP10210	XFMR, 40 VA
T1	PP10429	XFMR, 80 VA
TB1,TB2	P5045282	BLOCK, 4 POST BARRIER
TB3,TB4	P5047302	BLOCK, 2 POST BARRIER
VR1,VR2	B5307303	VARISTOR, SNUBBER MOV 56V 2000A

ME14 DOMESTIC FULL & SPLIT VAT HI POWER SCHEMATIC 700246H

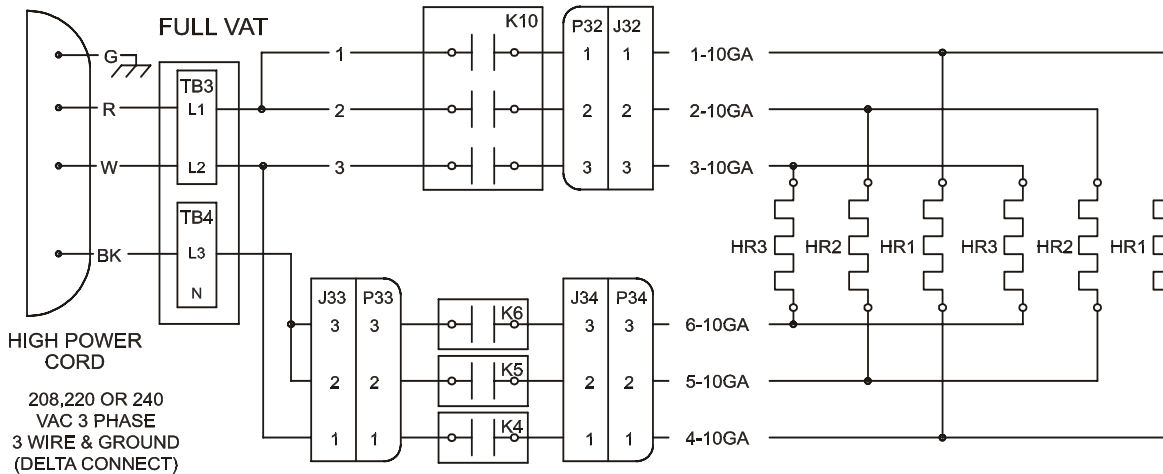
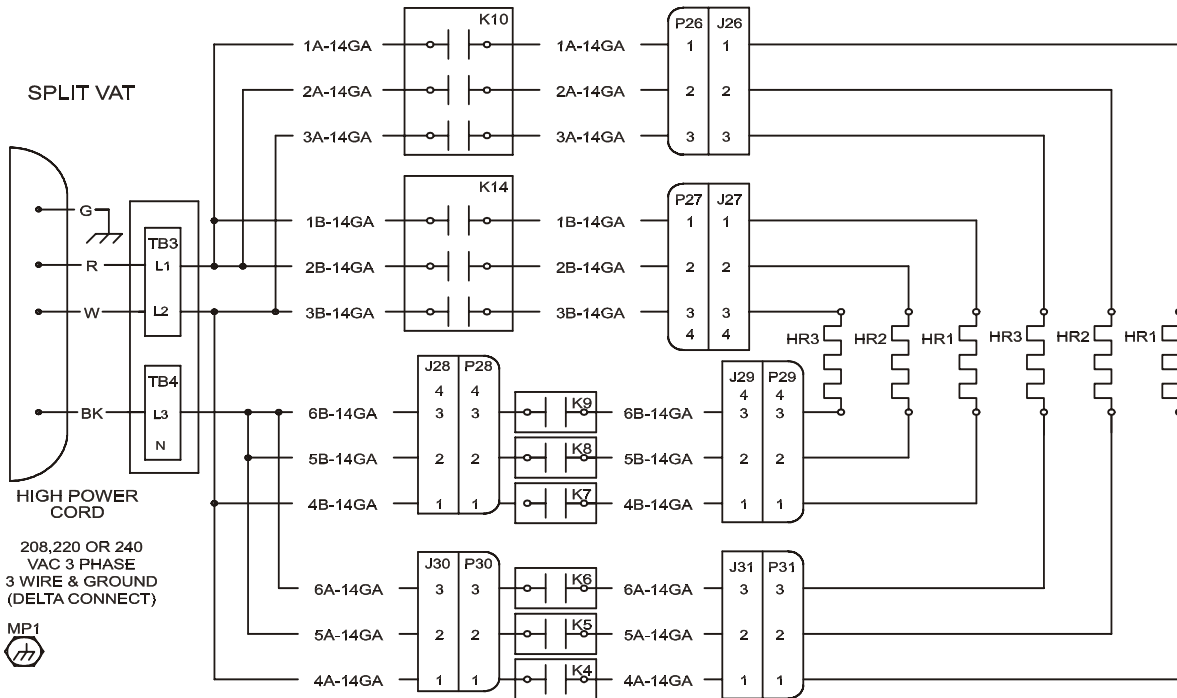

NOTES:

1. RELAY K15 IS ONLY ON LEFT HAND FRYERS. TB1 MUST BE INSTALLED IN ALL FRYERS, IT PROVIDES WIRE POSITIONS FOR RED AND BLUE POWER CIRCUIT.
2. TERMINAL BLOCK TB2 REQUIRES ONE DIODE(D1) FOR FULL VAT, (D1,D2) FOR SPLIT VAT.
3. 120 VAC MODELS: CONNECT RED LEAD TO PIN 3 ON T1.
220, 230, 240 VAC MODELS: CONNECT RED LEAD TO PIN 1 ON T1.
4. ALL WIRE 18GA UNLESS OTHERWISE SPECIFIED.
5. HI-LIMITS (S1 AND S2) LOCATED IN PIVOT BOX.
6. CIRCUIT BREAKER (CB1) TO BE DOUBLE POLE ON 220V AND 240V MOTOR BREAKING BOTH LEGS. CB1 FOR 115V TO BE SINGLE POLE. UNITS WITHOUT HEATER OPTION WILL HAVE YELLOW AND WHITE WIRES AT CB1 JUMPED TOGETHER, BYPASSING CB1.

In the event of problems with or questions about your order, please contact the Pitco Frialator factory, from 8:00 a.m. - 5:00 P.M., Eastern Standard Time, Monday through Friday, toll-free at:

(800)258-3708 US and Canada only or
(603)225-6684 World Wide

In the event of problems with or questions about your equipment, please contact the Pitco Frialator Authorized Service and Parts representative (ASAP) covering your area, through the National Service Network at:

(800)298-1862 US only, 24 hours