

**Application and Installation Bulletin for Master-Bilt® Refrigeration Superheat Controller Kit Assembly(A900-22007), 120/208/240/1/60, R404A, LT/MT APPS**

**Introduction**

The superheat controller is designed to control Master-Bilt made evaporator system to replace the mechanical thermal expansion valve. Each **Master-Bilt® Refrigeration Superheat Controller Kit** contains a Master-Bilt® Superheat Controller, one electric expansion valve, one pressure transducer, one temperature sensor and one 24VAC/40VA, 120/208/240 V primary input transformer.

Since it is a TRUE SUPERHEAT control, the evaporator will achieve the highest possible efficiency. The unique design of the control algorithm also permits the compressor head pressure to be free floated within its operating range with variable ambient temperature. Therefore, the refrigeration system in low ambient condition can achieve the highest possible Energy Efficiency Ratio.

Below Picture 1 shows the basic components in this control kit.



Picture 1. Superheat Controller Kit

## True Superheat Control

Picture 2 below shows us how TRUE SUPERHEAT is measured at a freezer evaporator.

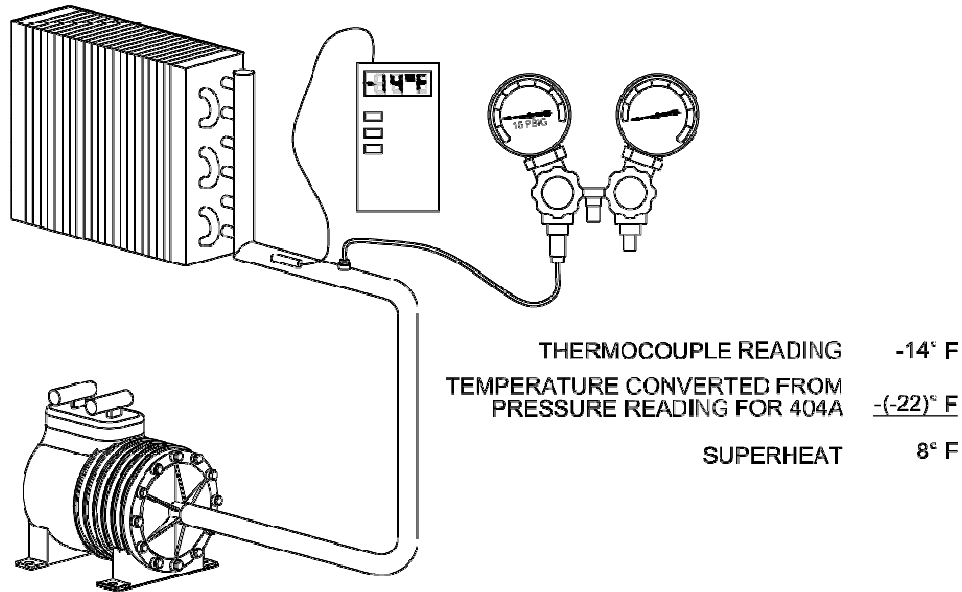

Picture 2

Picture 3 is the control schematic drawing to show us how the Master-Bilt<sup>®</sup> electronic superheat controller works.

The suction pressure transducer is mounted at suction line or header to measure the evaporating pressure. The controller stores the P-T chart of Refrigerant R404A and converts the suction pressure into saturated temperature. For example, if the pressure is 15.0 PSIG, the saturated or evaporating temperature is about -22°F.

The suction outlet temperature sensor is mounted on the suction line about 4 to 6" outside the evaporator to measure the superheated vapor temperature. In this case, if the suction outlet temperature is measured -14°F, **the evaporator TRUE SUPERHEAT is the suction outlet temperature minus the evaporating temperature**, or  $-14^{\circ}\text{F} - (-22^{\circ}\text{F}) = 8^{\circ}\text{F}$ .

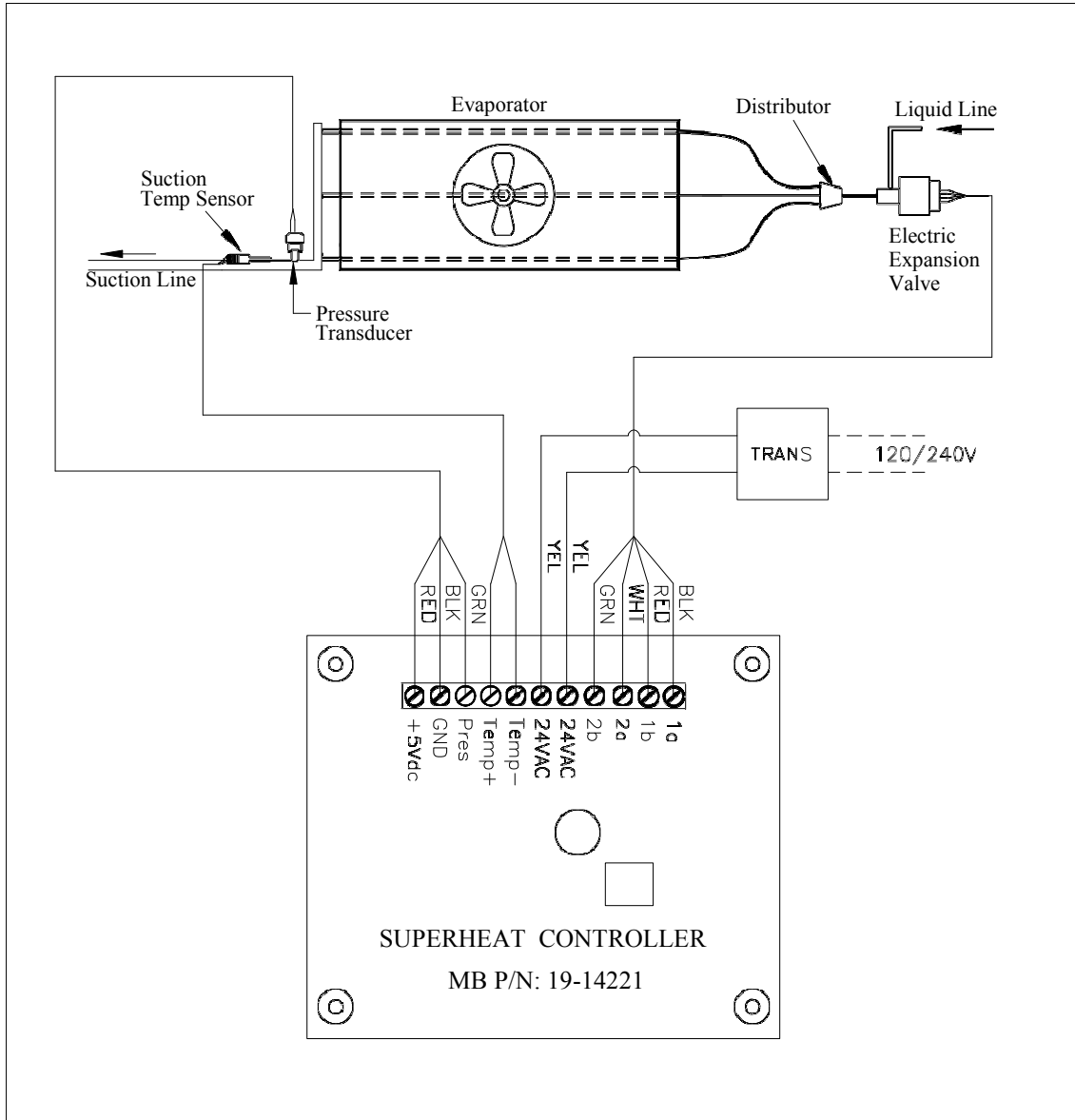

Picture 3

Superheat is the measurement of level of liquid refrigerant converted to vapor inside the evaporator tubes by absorbing heat from ambient air. When the superheat is higher than 0°F, we say the refrigerant changes from liquid phase to vapor phase completely. If the superheat is less than 0°F or close to it, there will be some un-vaporized liquid present at the evaporator outlet. This liquid may flood back to compressor and may cause harm.

Therefore, a certain superheat is required to maintain the evaporator working at high efficiency while prevent liquid refrigerant from flooding back to the compressor. **Master-Bilt uses typical 10 °F superheat for most of its applications.**

When the true superheat is higher than 10°F while in cooling mode, the controller will tell the electric expansion valve open more steps to allow more refrigerant entering to the evaporator. The controller will modulate the electric expansion valve in closing direction when it sees the true superheat is less than the set point of 10°F. The evaporator works at the highest possible efficiency since the controller operates at fast reaction time and uses PID valve control algorithm.

### Floating Head Pressure

In a typical Master-Bilt® Master Controller refrigeration system, the head pressure of a condensing unit is allowed to be freely floating. The compressor will work at less head pressure and less input power while output more cooling capacity at low ambient temperature. This is to say the system of floating head pressure will save more energy than the system with head pressure control valve where a typical head pressure limit is set at 225 PSIG. For example, a Copeland ZF13 Scroll compressor working at -20°F suction temperature:

The typical mechanical head pressure set point:           225 PSIG  
Outdoor condenser design TD  
(Condensing Temperature – Ambient Temperature):   20 °F

At 50°F ambient temperature, the condensing unit **with head pressure control** valve:

Evap Temp (F)	= -20
Suct Press (PSIG)	= 16
Cond Temp (F)	= 97
Head Press (PSIG)	= 225
Cooling Capacity (BTUH)	= 15700
Power (Watts)	= 2670
Current (Amps)	= 8.6
Mass Flow (lbs/hr)	= 268
EER (BTUH/W)	= 5.9

At 50°F ambient temperature, the condensing unit **without head pressure control** valve:

Evap Temp (F)	= -20
Suct Press (PSIG)	= 16
Cond Temp (F)	= 70
Head Press (PSIG)	= 148
Cooling Capacity (BTUH)	= 18900
Power (Watts)	= 2100
Current (Amps)	= 7.4
Mass Flow (lbs/hr)	= 276
EER (BTUH/W)	= 9

For a freezer requiring 15700 BTUH at 18 Hour Compressor Runtime, the energy consumption is equal to Power x Runtime = 2.67 KW x 18 H = 48.06 KWH per day.

When the condensing unit ***without head pressure control*** valve is used for this same freezer, the compressor runtime will be =  $(15700/18900) \times 18H = 14.95 H$ . The energy consumption is equal to Power x Runtime = 2.1 KW x 14.95 H = 31.40 KWH per day.

Therefore, total of  $48.06 - 31.40 = 16.66$  KWH energy is saved per day. Consider \$0.10 per KWH energy cost, then  $365 \text{ days} \times 16.66 \text{ KWH/Day} \times \$0.10 /\text{KWH} = \$608.09$  saving per year.

The average daily temperature of Year 2009 in Chicago: 48.6 °F

The average daily temperature of Year 2009 in Denver: 49.1 °F

The average daily temperature of Year 2009 in Boston: 50.3 °F

For a refrigeration system with free floating head pressure, it saves energy when the ambient temperature is lower than 77 °F

For further detailed calculation of how much energy is to be saved, please consult Master-Bilt engineering for Bin Analysis Energy Savings.

### **Summary of Benefits of Master-Bilt Electronic Superheat Control**

- Significant energy savings from reduced head pressure in low ambient conditions.
- Energy savings from high efficient evaporator operation.
- Fast pulldown
- Closer temperature control
- Extended product life --- Shelf life and compressor life expectancy
- Short ROI

Picture 4 indicates the comparison of pull times of a system between superheat control of EEV and regular mechanical control of TEV.

A typical Sporlan SER-6, or rated 6 ton electric expansion valve, can cover most of applications from 1/2 to 6 ton evaporators.

### Quicker Pulldown with Electric Expansion Valve (EEV)

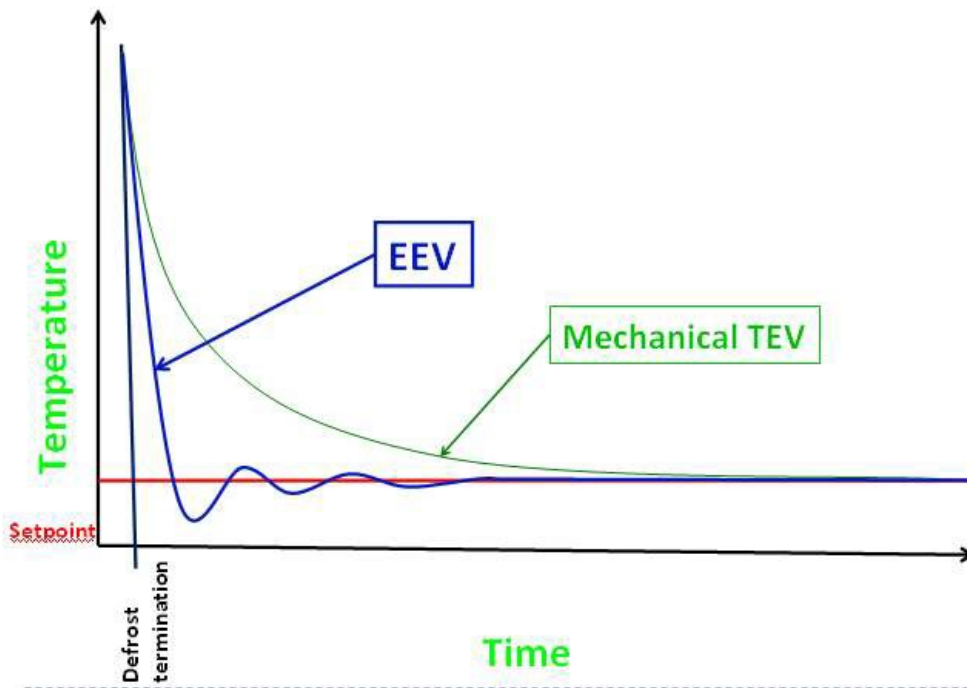

Picture 4

### Hardware Specifications



Picture 5

## Master-Bilt Electronic Superheat Controller Bulletin

- A. Dimension: 3.25" x 3.25"
- B. Mounting Hole: 2.75" x 2.75", Require 4 x #4 x 1" bolts and nuts
- C. Screw terminal connectors
  
- D. Used with Sporlan SER valves
  - a. Calibrated for a valve that is a 12 VDC, > 50 ohm coils, bipolar stepper motor.
  - b. Step rate is 200 steps per second
  - c. Number of steps for full stroke is 1600
  - d. If using a Sporlan valve, make following connections
    - i. Black lead to terminal labeled '1a'
    - ii. Red lead to terminal labeled '1b'
    - iii. White lead to terminal labeled '2a'
    - iv. Green lead to terminal labeled '2b'
  
- E. 24 VAC power in
  - e. 20 to 26.5 VAC, nominal 20 VA supplied input power
  - f. Connected to 2 terminals labeled '24 VAC', not polarity sensitive
  
- F. 1, Temperature sensor input\*
  - g. Calibrated for a 2k, NTC Thermistor
  - h. Connected to 2 terminals labeled 'TEMP+, TEMP-', not polarity sensitive.
  
- G. 1, Pressure transducer input
  - i. Calibrated for a 0-150 psia, 0.5 to 4.5 vdc output
  - j. Red lead connected to terminal labeled '+5vdc'
  - k. Black lead connected to terminal labeled 'Gnd'
  - l. White or green lead connected to terminal labeled 'Pres'
  
- H. 3 LEDs
  - m. If the green LED is on and the red and amber LEDs are off, everything is OK
  - n. If the red LED is on and the green and amber LEDs are off, the pressure transducer sensor is in alarm. The valve is closed.
  - o. If the amber LED is on and the green and red LEDs are off, the temperature sensor is in alarm. The valve is closed.
  - p. If the amber and green LEDs are on and the red led is off, there is a low superheat alarm. This occurs if the superheat is below 3 Deg F for 5 minutes or the superheat is 2 or more degrees below the superheat set point for 90 minutes. There is no default
  - q. If the red and green LEDs are on and the amber led is off, there is a high superheat alarm. This occurs if the superheat is 8 or more degrees above the superheat set point for 90 minutes. There is no default.

- I. For 2 pin header labeled 'CN4'
  - r. If 2 pins are jumpered, it is a medium temperature application
    - i. The Maximum Operating Set Point is 80 psig.
  - s. If 2 pins are open, it is a low temperature application
    - i. The Maximum Operating Set Point is 55 psig.
- J. Conformal coated circuit board rated at -40°F
- K. Pre-set 10° F superheat

*\*Temperature sensor also operates as a pumpdown control when supplied with an electrical short across the terminals*

## **Operations**

A typical refrigeration system with the superheat controller is illustrated as Picture 6. The system is piped and wired as a conventional system. The superheat control kit replaces the TXV valve. A power supply should be provided at field to the 24VAC transformer of the superheat controller. The head pressure control valve is removed or disabled from the system. Other components stay the same.

When power is turned on to the system, the liquid line solenoid valve is energized by closing temperature control. The suction pressure rises up to cut-in the low pressure control at the condensing unit. The compressor comes on. The superheat control starts modulating the EEV first at MOP (Maximum Operating Suction Pressure, MOP = 80 PSIG for Medium Temperature and 55 PSIG for Low Temperature Applications for R404A). When the suction pressure is lower than MOP, the superheat controller will modulate the EEV at TRUE SUPERHEAT.

When the refrigerated box temperature is satisfied, the solenoid valve is de-energized then the system is pumping down. The compressor is shut off when suction pressure drops to the cut-out pressure by low pressure control.

When the defrost timer is calling for defrost, the solenoid valve is de-energized the whole during defrost.

During off mode of the system when the compressor is not running and the defrost mode, the superheat controller will still modulate the EEV until it sees the TRUE SUPERHEAT below 3 °F. It then keeps the EEV shut. When the defrost cycle is complete, the solenoid valve is energized again and the system resumes normal cool cycle.

During off mode or defrost mode, the Green LED and Amber of the control board may be on to indicate the evaporator superheat is lower than 3 °F. These

warning signals can be ignored by design since the superheat of these modes does not affect the system operations.

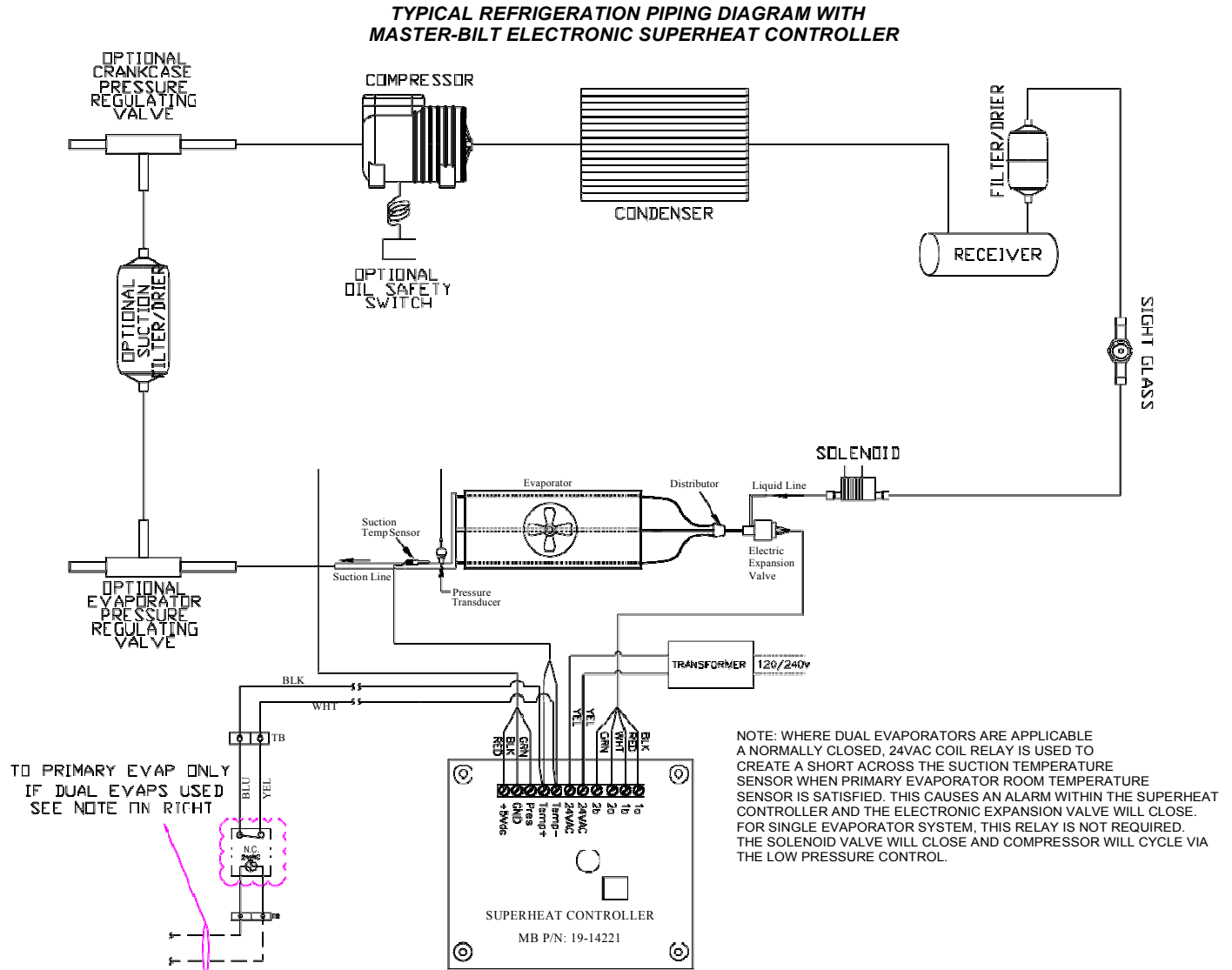

Picture 6

**Installation**

For evaporator shipped with the superheat controller, all parts are factory-mounted.

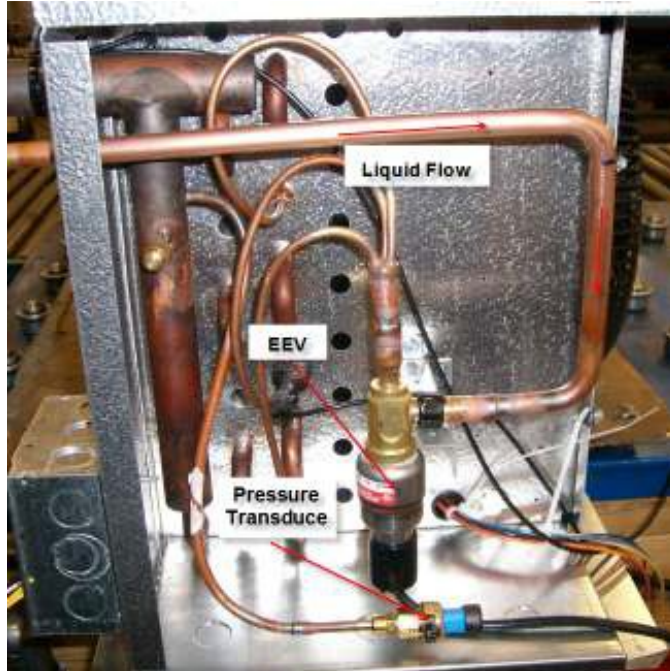

Picture 7

Picture 7 shows how and where the electric expansion valve and the pressure transducer are mounted. The suction pressure transducer is seen on the balanced tube in the picture but it can be also mounted on the service Schrader port as shown in Picture 8.

The 24VAC transformer and the suction outlet temperature sensor are mounted as shown in Picture 8.

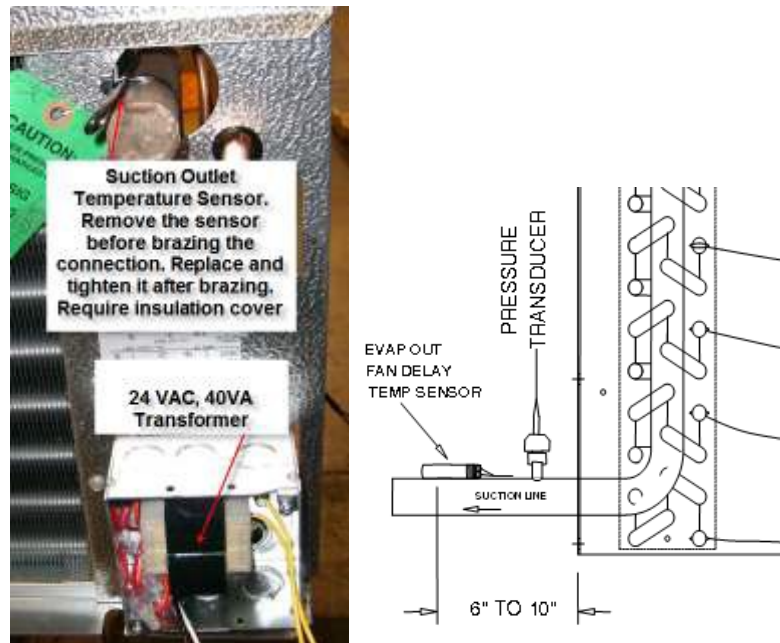

Picture 8

The controller can be mounted inside the end plate as show in Picture 9 or on the back side of the evaporator front panel as show in Picture 10.



Picture 9



Picture 10

Following are the procedures for field retrofit application:

1. Power down the system
2. Reclaim refrigerant
3. Remove TEV,
4. install EEV, Connect the liquid line to EEV side port
5. Install pressure sensor
6. Install temperature sensor
7. Install Simple Superheat board, mounting screws provided
8. Install 24 vac supply
9. Wire board
10. Set board (Remove Jumper CN4 for Low Temp Application)
11. Disable head pressure control valve
12. Recharge system
13. Start system

#### Typical System Wiring Diagrams

Picture 3 shows the superheat controller wiring diagram and Picture 6 shows a typical system drawing. In Picture 6, the liquid line solenoid valve should be controlled by the temperature control of the refrigeration system. For individual system wiring diagram, please consult factory or technical service.

## Troubleshooting

1. Ensure 1 or more LEDs are on. (See LED section above)
  - a. Make sure 20 to 26.5 VAC or DC power is on and measured across terminals labeled '24VAC'
  - b. If voltage is there, but no LEDs are on, replace board.
2. To ensure correct voltage is being supplied to the valve
  - a. Cycle 24 V power to controller.
  - b. Immediately after turning power back on, measure 10 to 15 VAC, not DC across terminals labeled '1a' and '2a'
  - c. Also measure 10 to 15 VAC, not DC across terminals labeled '1b' and '2b'
    - i. If correct voltage is not present, turn off power and disconnect valve leads from controller
    - ii. Repeat steps a, b, c again
    - iii. If correct voltage is not present, replace controller, else replace valve
3. If red LED is on, or pressure reading is suspected as out of tolerance,
  - a. Check wiring of pressure transducer
    - i. Red lead is connected to terminal labeled '+5 vdc'
    - ii. Black lead is connected to terminal labeled 'Gnd'
    - iii. White lead is connected to terminal labeled 'Pres'
  - b. DC voltage measured across terminals labeled '+5 vdc' and 'Gnd' should be 4.8 to 5.2 VDC.
    - i. If correct voltage is not present, disconnect pressure transducer from controller
    - ii. Remeasure voltage as in step 3.a
    - iii. If correct voltage is still not present, board is bad
    - iv. If correct voltage is present, pressure transducer is bad or cable is bad
  - c. Measure DC voltage across terminals labeled 'Pres' and 'Gnd'
    - i. Pressure = Measured dc voltage – 0.887) x 37.5
      1. Ex: if measured voltage is 1.5 VDC, pres = (1.5 - .887)\*37.5=22.9875 psig
    - ii. Compare calculated pressure from voltage reading to reading taken from external gauge. If the comparison is not within 5 psig, replace pressure transducer
    - iii. If pressure transducer measures OK, but red LED is on or pressure reading is still suspected as bad, replace controller
4. If amber LED is on, or temperature reading is suspected as out of tolerance,
  - a. Disconnect temperature sensor from controller
  - b. Measure resistance across leads of temperature sensor
  - c. Find temperature from temperature/resistance chart below
  - d. Compare temperature to temperature read from external source
  - e. If comparison is not within 5 deg F, replace sensor

f. If Temperature measures OK, but red LED is on or temperature reading is still suspected as bad, replace controller

Deg F	Resistance	Deg F	Resistance	Deg F	Resistance	Deg F	Resistance
-60	58820	-5	12421	50	3454	100	1301
-55	50653	0	10941	55	3109	105	1189
-50	43451	5	9651	60	2805	110	1090
-45	37407	10	8544	65	2535	115	997
-40	32310	15	7579	70	2294	120	917
-35	27957	20	6731	75	2079	125	841
-30	24267	25	5993	80	1888	130	775
-25	21127	30	5349	82	1817	135	714
-20	18432	35	4781	85	1716	140	659
-15	16117	40	4281	90	1562	145	609
-10	14130	45	3841	95	1424	150	562

### Ordering Information

Use the assembly kit number A900-22007 to order all parts required for field retrofit.

A900-22007 Master-Bilt® Refrigeration Superheat Controller Kit  
 Assembly, 120/208/240/1/60, R404A, LT/MT APPS

A900-22007 contains the following parts:

Part Number	Description	Quantity
19-13772	Electric expansion valve SER-6, 1/2" ODF x 1/2" ODF	1
19-13967	NTC thermistor assembly, 30" long	1
19-14099	1/2" LONG ROUND PLASTIC SPACER	4
19-14221	Self-contained Superheat Controller board with conformal coating and screw down terminal blocks	1
19-14223	Pressure transducer, Lead 16", 0 to 150 psia, Green Signal, RED +5VDC, Black Ground	1
29-01695	Clear polycarbon window plug	1
39-01088	Transformer, 40VA, 120/208/240V Primary, 24VAC Output	1
43-13214	#4-40 x 1" Pan Head PHIL ZINC	4
43-13215	#4-40 HEX NUT ZINC	4
43-13216	#4 Flat Washer ZINC	4
57-02155	Application and Installation Instructions for A900-22007	1

Master-Bilt Electronic Superheat Controller Bulletin

Please contact Master-Bilt Sales Department or Customer Service for ordering replacement parts.

If there's any question, please call Master-Bilt technical service department @

**Master-Bilt Products  
Technical Service Department  
Highway 15 North  
New Albany, MS 38652  
Phone: 800-684-8988  
Fax: 800-684-8988  
Email: [service@master-bilt.com](mailto:service@master-bilt.com)**