

MB MASTER-BILT[®] Refrigeration Solutions



Installation & Operations Manual for

MB MASTER-BILT[®] FUSION PLUS[™]

MBGFP-HG Model
Bottom Mounted Swing Glass Door
Freezer Merchandisers With Lighted Sign

TABLE OF CONTENTS

INTRODUCTION.....	4
STORE CONDITIONS.....	4
WARNING LABELS AND SAFETY INSTRUCTIONS.....	5
PRE-INSTALLATION INSTRUCTIONS.....	6
Inspection for Shipping Damage.....	6
INSTALLATION INSTRUCTIONS.....	6
General Instructions.....	6
MECHANICAL.....	6
ELECTRICAL.....	7
Leg / Caster Installation.....	7
DOORS.....	8
Grill.....	8
ELECTRONIC REFRIGERATION CONTROL.....	9
Programming.....	10
List of Parameters.....	10
Electrical connections.....	10
Probes connections.....	10
CHECK LIST.....	11
SERVICE INSTRUCTION.....	11
TEMPERATURE SENSOR, DEFROST HEATER AND FAN MOTOR REPLACEMENT.....	13
PART LIST.....	14
ACCESSORIES	14
SALE AND DISPOSAL.....	15
WIRING DIAGRAMS.....	16

INTRODUCTION

This manual contains important instructions for installing, using, and servicing a **MBGFP** Fusion Plus case. A parts list is included with this manual. Read all these documents carefully before installing or servicing your equipment.

STORE CONDITIONS

The **MBGFP** cases are designed to operate in the controlled environment of an air-conditioned store. The store temperature should be at or below 75° F and a relative humidity of 55% or less. At higher temperature or humidity conditions, the performance of these cases may be affected and the capacity diminished.

The **MBGFP** cases should not be positioned where it is directly exposed to rays of sun or near a direct source of radiant heat or airflow. This will adversely affect the case and will result in poor performance.

If this case is to be located against a wall, there should be at least 6" space between the wall and the back of the case. This space will allow for the circulation of air behind the case, which will prevent condensation on the exterior surfaces.



NOTICE

Read this manual before installing your cabinet. Keep the manual and refer to it before doing any service on the equipment. Failure to do so could result in personal injury or damage to the cabinet.



DANGER

Improper or faulty hook-up of electrical components on the refrigeration units can result in severe injury or death.

All electrical wiring hook-ups must be done in accordance with all applicable local, regional or national standards.



NOTICE

Installation and service of the refrigeration and electrical components of the cabinet must be performed by a refrigeration mechanic and/or a licensed electrician.

The portions of this manual covering refrigeration and electrical components contain technical instructions intended only for persons qualified to perform refrigeration and electrical work.

This manual cannot cover every installation, use or service situation. If you need additional information, call or write our customer service Department.

WARNING LABELS AND SAFETY INSTRUCTIONS



This symbol is the safety-alert symbol. When you see this symbol on your cabinet or in this manual, be alert to the potential for personal injury or damage to your equipment.

Be sure you understand all safety messages and always follow recommended precautions and safe operating practices.



NOTICE TO EMPLOYERS

You must make sure that everyone who installs, uses or services your cabinet is thoroughly familiar with all safety information and procedures.

Important safety information is presented in this section and throughout the manual. The following signal words are used in the warnings and safety messages:

DANGER: Severe injury or death will occur if you ignore the message.

WARNING: Severe injury or death can occur if you ignore the message.

CAUTION: Minor injury or damage to your cabinet can occur if you ignore the message.

NOTICE: This is important installation, operation or service information. If you ignore the message, you may damage your cabinet.

The warning and safety labels shown throughout this manual are placed on your Products cabinet at the factory. Follow all warning label instructions. If any warning or safety labels become lost or damaged, call your customer service department for replacements.

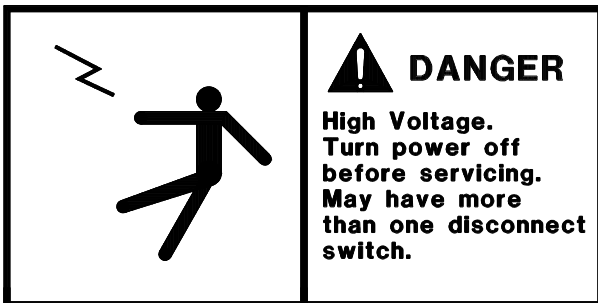

This label is located on top of the electrical control label and on the wiring channel.



This label is attached to the cabinet power cord on models with a power cord.

PRE-INSTALLATION INSTRUCTIONS

INSPECTION FOR SHIPPING DAMAGE

You are responsible for filing all freight claims with the delivering truck line. Inspect all cartons and crates for damage as soon as they arrive. If damage is noted to shipping crates or cartons or if a shortage is found, note this on the bill of lading (all copies) prior to signing.

If damage is discovered when the cabinet is uncrated, immediately call the delivering truck line and follow up the call with a written report indicating concealed damage to your shipment. Ask for an immediate inspection of your concealed damage item. Crating material must be retained to show the inspector from the truck line.

INSTALLATION INSTRUCTIONS

GENERAL INSTRUCTIONS

1. Be sure the equipment is properly installed by competent service people.
2. Keep the equipment clean and sanitary so it will meet your local sanitation codes. Clean the cabinet with a mild detergent and water, then rinse.
3. Rotate your stock so that older stock does not accumulate. This is especially important for ice cream. A "First-In, First-Out" rotation practice will keep the products in good salable condition.
4. Do not place product in the case when it is soft or partially thawed. Also, product should not be put in the case for at least 6 hours after it is started.
5. Stock cases as quickly as possible, exposing only small quantities to store temperatures for short periods of time.
6. When replacing burned out light bars, be sure that the electrical power to the lighting circuit is turned off.

NOTICE TO STORE OWNERS / MANAGERS

Moisture or liquid around or under the cabinet is a potential slip/fall hazard for persons walking by or working in the general area of the cabinet. Any cabinet malfunction or housekeeping problem that creates a slip/fall hazard around or under the cabinet should be corrected immediately.

If moisture or liquid is observed around or under the cabinet, an immediate investigation should be made by qualified personnel to determine the source of the moisture or liquid. The investigation should determine if the cabinet is malfunctioning or if there is a drainpipe leaking.

MECHANICAL

Remove front grille and check refrigeration lines to see that they are free (not touching each other or compressor). Spin condenser fan blade to see that it is free.

Remove cabinet from crate base and slide into location. Cabinet must be level from side to side and front to back for correct draining of coil pan and for self-closing doors to operate correctly. Allow minimum of 4" between back of cabinet and wall and between top of cabinet and ceiling for proper condensing unit air circulation.

To comply with Sanitation requirements the cabinet must be mounted on legs (6" high min.), casters, or the base must be sealed to the floor with an N.S.F. listed silicone sealant. When sealing to the floor, leveling bolts can be used to assure the cabinet is level before applying silicone sealant.

ELECTRICAL

WARNING



Before servicing electrical components in the case or the doors or door frames make sure all power to case is off. Always use a qualified technician.

Check voltage and amps drawn on (**TABLE 2**) to determine proper line and fuse or circuit breaker size. Check power supply for low voltage.

For example: If voltage reads “230” with no load, and it drops below “207” when the compressor tries to start, it is an indication of too small supply wiring or too long to run.

It is recommended that a separate circuit be run for each cabinet to prevent another appliance blowing the fuse or breaker, causing loss of product.

IMPORTANT



Models (3 door cabinet) are pre-wired internally with a 208-230V NEMA L14-20P plug and should only be plugged into a NEMA L14-20P receptacle. See wiring diagrams for more details. The cabinet should be grounded.

LEG / CASTER INSTALLATION

1. Screw legs / casters tightly into the rail base mounting holes.

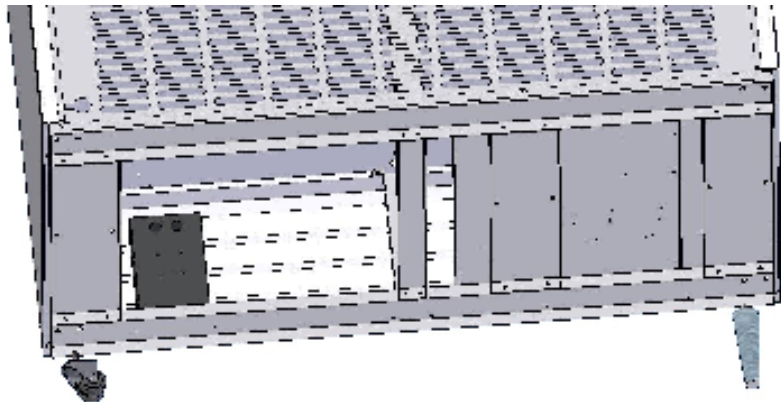

DOORS

The cabinets have Anthony glass doors that are equipped with a patented TorqueMaster™ hinge system. The doors are easily adjusted using a flathead screwdriver (Fig.3).

* *The tension needs to be checked and set when first install.*

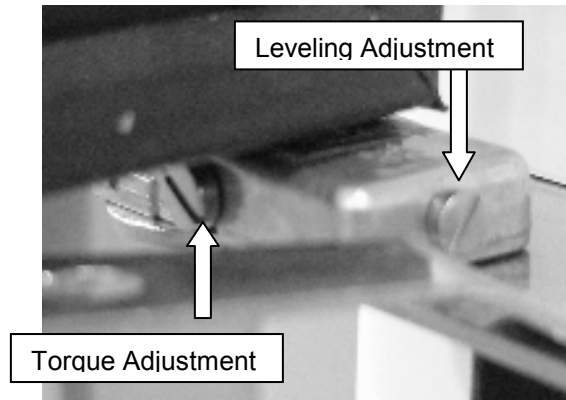

Figure 3

GRILL

To remove bottom grill, unscrew the 2 screws on the bottom for the grill then drop the grill down from the key-slot hole and pull out. (See Figure 4)

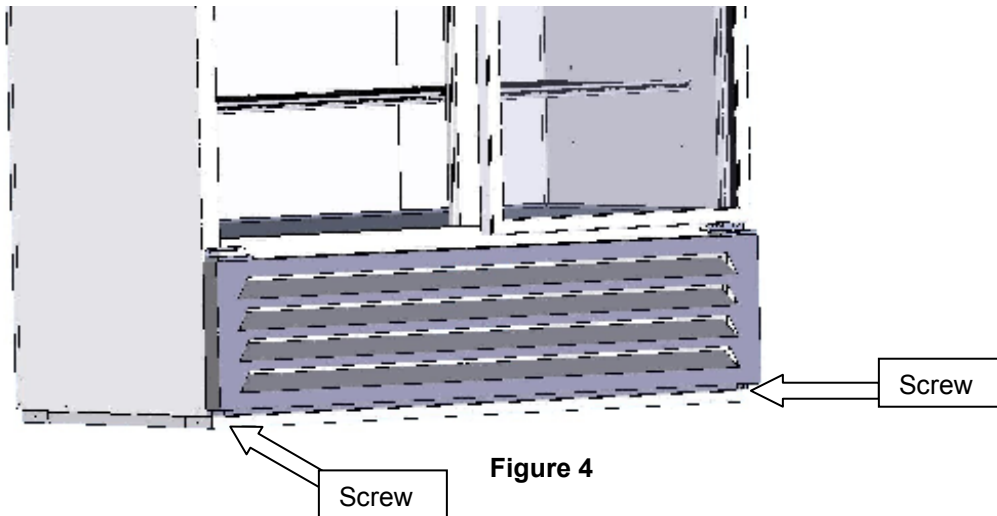

Figure 4

ELECTRONIC REFRIGERATION CONTROL

DESCRIPTION



Fig.1 — Front panel

- Info / Setpoint button.
- Manual defrost / Decrease button.

INDICATIONS

- Thermostat output
- Fan output
- Auxiliary output
- Activation of 2nd parameter set
- Alarm

- Increase / manual activation button.
- Exit / Stand-by button.

OPERATION

DISPLAY

During normal operation, the display shows either the temperature measured or one of the following indications:

DEF	Defrost in progress	HI	Room high temperature alarm
REC	Recovery after defrost	LO	Room low temperature alarm
OFF	Controller in stand-by	E1	Probe T1 failure
CL	Condenser clean warning	E2	Probe T2 failure
DO	Door open alarm		

INFO MENU

The information available in this menu is:

T1	Instant probe 1 temperature	TLO	Minimum probe 1 temperature recorded
T2	Instant probe 2 temperature	CND	Compressor working weeks
THI	Maximum probe 1 temperature recorded	LOC	Keypad state lock

Compressor When power is first turned on the controller will go through the start-up. After the start-up delay the compressor comes on. The LED indicator stays on while compressor relay is energized. Display will show actual box temperature. Picture above is the display layout. The compressor will be cycled off when the actual box temperature reaches its set point. The compressor indicator will be off.





Fan The fans will run during cool mode, cycle during compressor off mode, and off when a defrost is initiated. When in defrost mode the fans are off until the end of the defrost and the 2 minute drip time has passed. There is 2 minutes delay after a defrost before the fan comes on. If the Evaporator temperature is 35 °F or below the controller will override the fan delay. FAN LED indicator is on while fan relay is energized.

Defrost The control uses time defrost with 4 defrost per day. The defrost setting can be reset for special applications. During defrost the display will show dEF and the defrost LED indicator will be on. The control begins timing the defrost when power is turned on. Four defrosts per day means it will occur every 6 hours. Example: to have defrost occur at 8am, 2pm, 8pm, and 2am then power up at one of these four times.











MANUAL DEFROST

Defrosting may also be induced manually by pressing the defrost button for 3 seconds. Once initiated, the unit will go through a normal defrost and drip time pull down cycle.

HOW TO CHANGE THE SETPOINT

- Press button  for at least half second, to display the setpoint value.
- By keeping button  pressed, use button  or  to set the desired value (adjustment is within the minimum **SPL** and the maximum **SPH** limit).
- When button  is released, the new value is stored.

HOW TO CHANGE a parameter value

- The setup menu is accessed by pressing button + for 5 seconds.
- With button  or  select the parameter to be modified.
- Press button  to display the value.
- By keeping button  pressed, use button  or  to set the desired value.
- When button  is released, the newly programmed value is stored and the following parameter is displayed.
- To exit from the setup, press button  or wait for 30 seconds.

LIST OF PARAMETERS

Here is a list of the parameters the value of which can be changed in the programming mode, as well as their ranges.

TABLE 1

Display Symbol	Parameter	Range	Factory Setting
SP	Temperature Set Point	SPL...SPH	-10°F or -15°F
HYS	Temperature Differential	1 to 255°F	10°
SPL	Minimum Temperature limit setpoint	-50...SPH	-15°F
SPH	Maximum Temperature limit setpoint	SPH...120°	30°F
AHA	High Temperature alarm	-50...120°	45°F
ALA	Low Temperature Alarm	50...120°	-30F
ATD	Temperature Alarm Delay	0...120min	30min
DFR	Number of Defrost Cycle per 24hr	0...24	4/day
DLI	Defrost Termination Temperature	-50...120°	55°F
DTO	Maximum Defrost Duration	1...120min	30min

ELECTRICAL CONNECTIONS

The controller is provided with a screw terminal block to connect cables with a cross section up to 2,5 mm². Before connecting cables make sure the power supply complies with the control's requirements. Separate the probe cables from the power supply cables, and the outputs and the power connections. Do not exceed the maximum current allowed on each relay. In case of heavier loads use a suitable external relay or contactor.

PROBE CONNECTIONS

The probes shall be mounted with the bulb upwards to prevent damage due to casual liquid infiltration. It is recommended to place the thermostat probe away from air streams to correctly measure the average room temperature. Place the defrost termination probe among the evaporator fins in the coldest place, where most ice is formed, far from heaters or from the warmest place during defrost to prevent premature defrost termination.

FINAL CHECK LIST

- A. Check operating pressures.
- B. Check electrical requirements of unit to supply voltage.
- C. Set temperature control for desired temperature range.
- D. Check sight glass for proper refrigerant charge, if provided.
- E. Check system for proper defrost settings and operation.
- F. Check condensing unit for vibrating or rubbing tubing. Dampen and clamp as required.
- G. All valves should be completely opened counter-clockwise.
- H. Check packing nuts on all service valves.
- I. Replace all service valve caps and latch unit covers.
- J. Check and set the door tension at the Torque Adjustment.

SERVICE INSTRUCTION

1. High head pressure and high back pressure:
 - A. Condenser coil clogged or restricted
 - B. Condenser fan motor defective.
 - C. Air discharge in rear of cabinet restricted.
2. Low back pressure and low head pressure:
 - A. Restriction in system.
 - B. Refrigerant undercharged.
 - C. Leak in system
3. Pressure normal – cabinet warm:
 - A. Coil blocked with frost (see #4).
 - B. Refrigerant undercharged.
 - C. Control set too warm.
4. Cabinet not cycling – coil blocked with frost:
 - A. Defective temperature controller.
 - B. Refrigerant overcharged.
 - C. Location too hot.
 - D. Condenser clogged.
 - E. Condenser fan motor defective.
 - F. Defrost heater not operating.
5. Copressor starts and runs – but cycles on overload:
 - A. Low voltage
 - B. Relay defective.
 - C. Overload defective.
 - D. High head pressure (see #1).

Temperature sensor, defrost heater and fan motor replacement

Before making any change, technician should:

1. Disconnect power to the cabinet
2. Remove screws from venturi and pull down

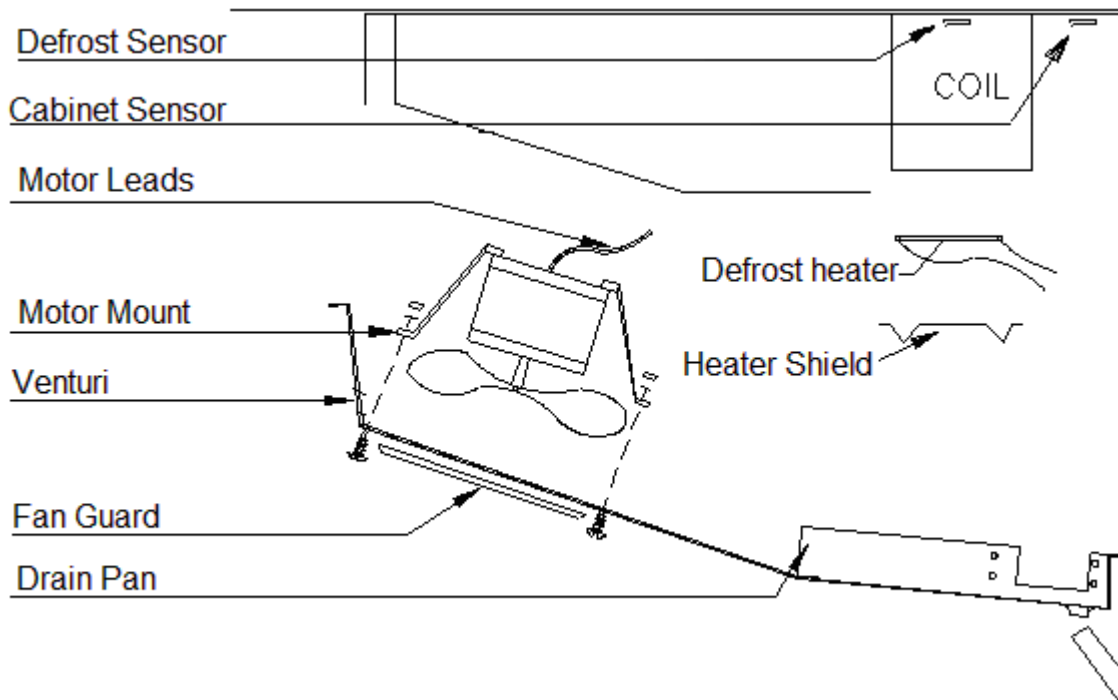

To change a temperature sensor (cabinet sensor or defrost sensor), simply disconnect the sensor wires from the controller and replace the new sensor in the original position. Use plastic tie to tighten the zone sensor. Insert the sensor for defrost termination firmly into top-center of the evaporator coil, in between the fins. Make sure the sensor wires do not touch or are not close to any heater rods.

To change defrost heater – remove screws from drain pan and pull down – remove screws from coil mounting straps – spring straps open – remove heater shield – pull heater out of slots in coil fins.

To change fan motor – disconnect fan motor leads – remove screws from fan guards and motor mounts.

PART LIST

The table below gives componet part numbers. Use this chart when ordering replacement parts for your **MBGFP** cabinets. Always Advise Cabinet Serial Number When Ordering Parts

	MBGFP23-HG	MBGFP27-HG	MBGFP48-HG	MBGFP74-HG
Ballast	23-01709	23-01709	23-01709	23-01709
Bulb	23-01576	23-01576	23-01575	23-01577
Lamp Holder	23-50562	23-50562	23-50562	23-50562
LED Light Bar (Single)	23-01835	23-01835	NA	23-01835
LED Light Bar (Double)	NA	NA	23-01833	23-01833
Female Door Plug	21-00568	21-00568	21-00568	21-00568
Light Switch	23-50793	23-50793	23-50793	23-50793
Expansion Valve	09-10407	09-10407	09-10408	09-10408
Evaporator Coil	07-14098	07-14098	07-14099	07-14100
Evaporator Fan Blade	15-13106	15-13106	15-13106	15-13106
Evaporator Fan Motor	13-13279	13-13279	13-13279	13-13279
Evaporator Fan Guard	25-01324	25-01324	25-01324	25-01324
Defrost Heater	17-09568	17-09568	17-09569	17-09570
Drain Line Heater	17-00404	17-00404	17-00404	17-00404
Defrost Heater Safety	19-01164	19-01164	19-01164	19-01164
Compressor	03-15192	03-15192	03-14902	03-14898
Condenser Coil	07-14088	07-14088	07-14089	07-14089
Condenser Fan Motor	13-13101	13-13101	13-13101	13-01283
Condenser Fan Blade	15-13093	15-13093	15-13093	15-13093
Drier	09-09171	09-09171	09-09171	09-09171
Thermometer	44-00963	44-00963	44-00963	44-00963
LAE Controller	19-14243	19-14243	19-14243	19-14243
LAE Sensor T1	19-14244	19-14244	19-14244	19-14244
LAE Sensor T2	19-14245	19-14245	19-14245	19-14245
Door - LH	31-03220	31-03221	31-03222	31-03222
Door - RH	NA	NA	31-03223	31-03223
Pilaster	33-01408	33-01408	33-01408	33-01408
Pilaster Clip	33-01011	33-01011	33-01011	33-01011
Wall Guard	25-01376	25-01376	25-01376	25-01376
Shelf (Sides)	33-01812 (W) 33-01813 (B)	33-01807 (W) 33-01808 (B)	33-01805 (W) 33-01806 (B)	33-01805 (W) 33-01806 (B)
Shelf (Middle)	NA	NA	NA	33-01807(W) 33-001808 (B)

Accessories (Includes HD Models)

Description	MBGFP23-HG	MBGFP27-HG	MBGFP48-HG	MBGFP74-HG
Casters (4) 3" Diameter	A20011140	A20011140	A200-11140	
Casters (6) 3" Diameter				A212-11140
Legs 6"	A20011170	A20011170	A200-11170	A212-11170

SALE AND DISPOSAL

OWNER RESPONSIBILITY

If you sell or give away your cabinet; you must make sure that all safety labels and the Installation - Service Manual are included with it. If you need replacement labels or manuals, factory will provide them free. Contact the customer service department at (800) 684-8988.

The customer service department should be contacted at the time of sale or disposal of your cabinet so records may be kept of its new location

If you sell or give away your cabinet and you evacuate the refrigerant charge before shipment, factory recommends that the refrigerant charge be properly recovered in compliance with section 608 of the Clean Air Act effective November 1995 and in accordance with all applicable local, regional, or national standards. The customer service department at Master-Bilt should be contacted at the time of sale or disposal of your cabinet so records may be kept of its new location.

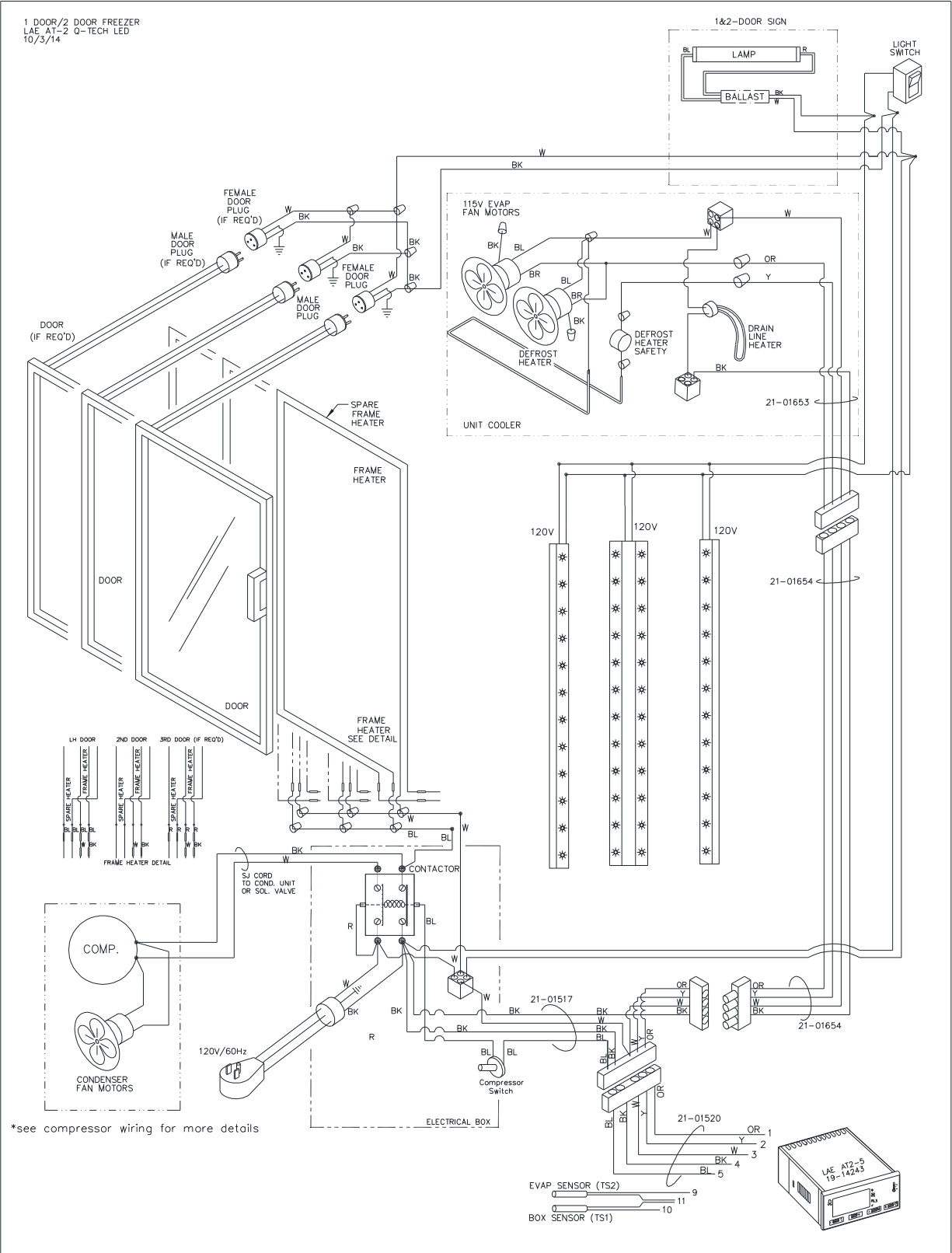

3 DOOR FREEZER
LAE_AT-2 Q-TECH LED
10/3/14

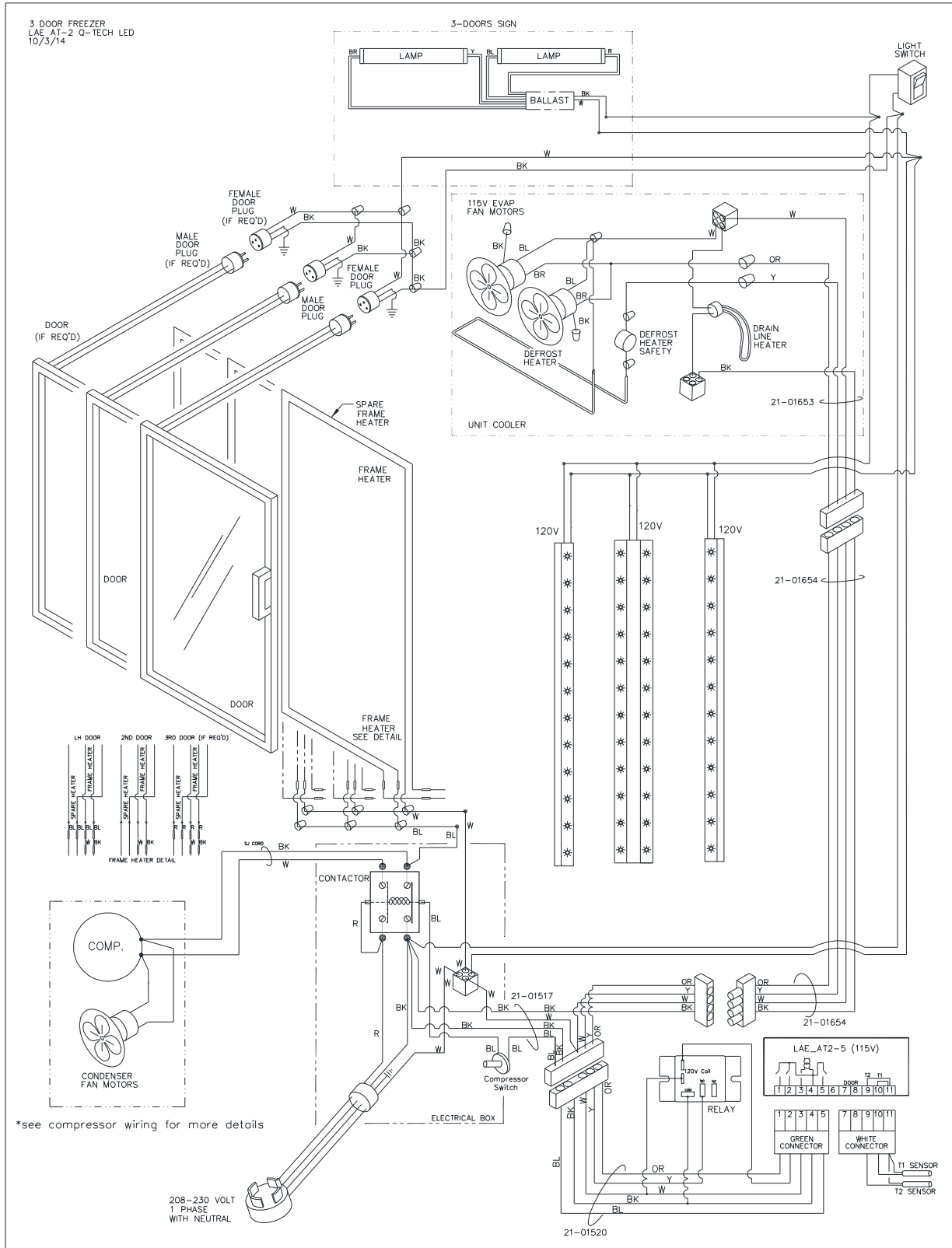



Customer Service/Warranty Parts
Phone: 800-684-8988
Fax: 866-882-7629
Email: service@master-bilt.com