DIRECT DRAW BEER COOLERS

Installation, Operation and Maintenance Instructions

INSPECTION

When the equipment is received, all items should be carefully checked against the Bill of Lading to ensure all crates and cartons have been received. Do not sign the freight bill clear until the freight has been properly inspected for damage. All units should be inspected for damage including concealed damage by uncrating immediately. If any damage is found, it should be reported to the carrier at once, noted on the Bill of Lading and a claim should be filed with the carrier. This equipment has been inspected and tested in the manufacturing facility and has been crated in accordance with transportation rules and guidelines. The manufacturer is not responsible for freight loss or damages.

INSTALLATION

CAUTION: This unit uses a flammable refrigerant. Use care when handling and operating to avoid damaging the refrigerant tubing or increasing the risk of a leak.

After removing the unit from the packaging, clean the interior and exterior surfaces of the unit with soap and water and a rinse with clean water. Do not use chlorinated cleaners on the surfaces as they can cause corrosion.

This unit is designed for indoor use only. Be sure to locate the unit where the floor can support the weight of the unit and product installed inside of it. The refrigeration system located at the bottom left of the unit requires free air access for proper operation. Allow a minimum of seven (7) inches between the back of the cabinet and the wall. Do not locate the unit next to heat generating equipment or in direct sunlight.

Confirm that the proposed electrical outlet has the correct voltage, frequency and current carrying capacity for the requirements of the unit. This information is noted on the data plate on the inside left wall of the unit. The unit should be isolated on a circuit. Do not use an extension cord to get power to the unit. Improper electrical installations will void the compressor warranty. To prevent shock and fire, be sure the unit is properly grounded.

Local health codes may require that the unit be sealed to the floor with an NSF approved silicone sealant if it is not on legs or casters. After the unit is set in its desired location, simply apply a bead of sealant around the base of the unit and smooth it out.

The drain pan under the beer spigots requires a floor drain (except model DD24). The drain line comes out the front of the unit and is terminated with two (2) ½" barbed fittings. The installer will need to add a drain line from this fitting to a floor drain. Model DD24 has an internal drain bottle that captures the beer from the drain pan. This bottle needs to be monitored and emptied as needed.

It is recommended that the beer delivery system be installed by your local beer distributor. Inside the unit (except on model DD24) there is a gas manifold to distribute gas pressure to the kegs. All gas and beer lines, keg taps and gas pressure regulators are not included but are supplied by your beer distributor. The installer will need to route the gas supply line through the cabinet in the back of the compressor compartment using one of the pre-cut holes and cutting out the foam insulation. All units except the DD24 will require a remote pressurized gas supply. The mobile model DD24 can accept a CO2 tank up to 5 pounds inside the cabinet and has a spring to hold the tank in place.

The beer towers come complete with all required mounting hardware. Set the black rubber gasket supplied with the tower in place on top of the cabinet aligning with the four mounting holes. Set the tower in place on the cabinet top by aligning the four mounting holes and secure the tower with the four screws provided. Inside the unit you will find one inch plastic air hose(s) with a wire hook on the end. Remove the top cap of the tower. Install the air hose up through the bottom of the tower and attach the wire hook to the top of the insulating foam sleeve at the top of the tower. Replace the top cap of the tower. This air hose supplies cool air to the tower to assure the beer remains cold in the tower. Install the spigot tap on the tower. Do this for each tower.

OPERATION AND MAINTENANCE

All service should be performed by factory authorized personnel. All component parts will be replaced with like components to minimize the risk of possible ignition due to incorrect parts or improper service.

This cooler is designed to maintain your product temperature within the most desirable range of +34°F to +38°F. You can expect this temperature with the proper temperature control setting and in a normal environment. It is important to remember that when the product is delivered, it must be placed inside the cooler as soon as possible to avoid excessive warm up. If this happens, it may take many hours for the temperature to be reduced to the desirable range.

The temperature controller is located on the left end of the unit cooler. Turn the control clockwise for cooler temperatures and counterclockwise for warmer temperatures. Allow the unit several hours to respond to temperature control adjustments.

There is a light with an on/off switch located on the unit cooler (except for model DD24).

This equipment is intended for the storage and display of non-potentially hazardous bottled or can product only.

Cleaning

Beginning with the initial installation, the interior surfaces of the cabinet should be periodically cleaned with a solution of warm water and baking soda. This solution will remove any odors from spillage that has occurred. The exterior of the cabinet should

also be cleaned frequently with a commercial stainless steel cleaner, glass cleaner or mild soap solution. Do not use chlorinated cleaners on any surfaces.

Note: do not use stainless steel cleaners or other solvent-based chemicals on the plastic parts (door handle or trim strips) as they can cause failure. Use mild soap and warm water on plastic parts.

Contact your local beer distributor for information on cleaning the beer lines.

Condenser Coil

Prior to cleaning the condenser coil disconnect the unit from power. Periodic cleaning of the condenser coil will aid the heat transfer of the refrigeration system and increase its efficiency. To accomplish this, remove the lower front grill from the cabinet. The condenser coil is located behind the grill. Use a soft bristled brush to remove any dirt particles that are on the fins of the condenser coil. Use a vacuum cleaner or compressed air to remove the loosened particles. Replace the front grill and reconnect the unit to power. Failure to clean the condenser coil can lead to performance loss and compressor failure.

SPECIFICATIONS*

Model	Doors	# of Towers / Taps	Electrical	Amps	NEMA Plug	HP	Refrigerant	Keg Capacity
DD24	1	1/1	115/60/1	3.5	5-15P	3/8	R290	1
DD59	2	2/2	115/60/1	3.5	5-15P	3/8	R290	2
DD69	2	2/2	115/60/1	3.5	5-15P	3/8	R290	3
DD80	3	2/3	115/60/1	3.5	5-15P	3/8	R290	4
DD95	3	2/4	115/60/1	3.5	5-15P	3/8	R290	5

* Above specifications are subjected to change without prior notice for quality improvement.

TROUBLESHOOTING

Problem	Remedy
Compressor will not start	<ul style="list-style-type: none"> • Check the power cord and make sure it is plugged in and has power. • Check the temperature controller. If it is in the “OFF” position, turn it clockwise to set a desired temperature.
Poor performance	<ul style="list-style-type: none"> • Move the unit from direct sunlight. • Move the unit away from heating devices. • Install the unit in a well ventilated place, with at least 2 inches of clearance on all sides. • Clean the condenser if heavy dust is collected. • Clear contents from blocking the inside air duct. • Check the temperature controller for correct setting. • Check the doors and be sure they are completely closed.
Unit noisy	<ul style="list-style-type: none"> • Install the unit on a level solid surface. • Maintain 2 inches of clearance from the wall. • Check for loose parts or mounting. • Keep the tubing free from any contact to avoid rattle.
Condensation on cabinet exterior and/or floor	<ul style="list-style-type: none"> • Reduce humidity where the unit is installed. • Check the drain line to make sure it is not disconnected inside the cabinet and it drains into the drain pan in the compressor area.

AIR HOSE & TOWER INSTALLATION SCHEMATIC DIAGRAM

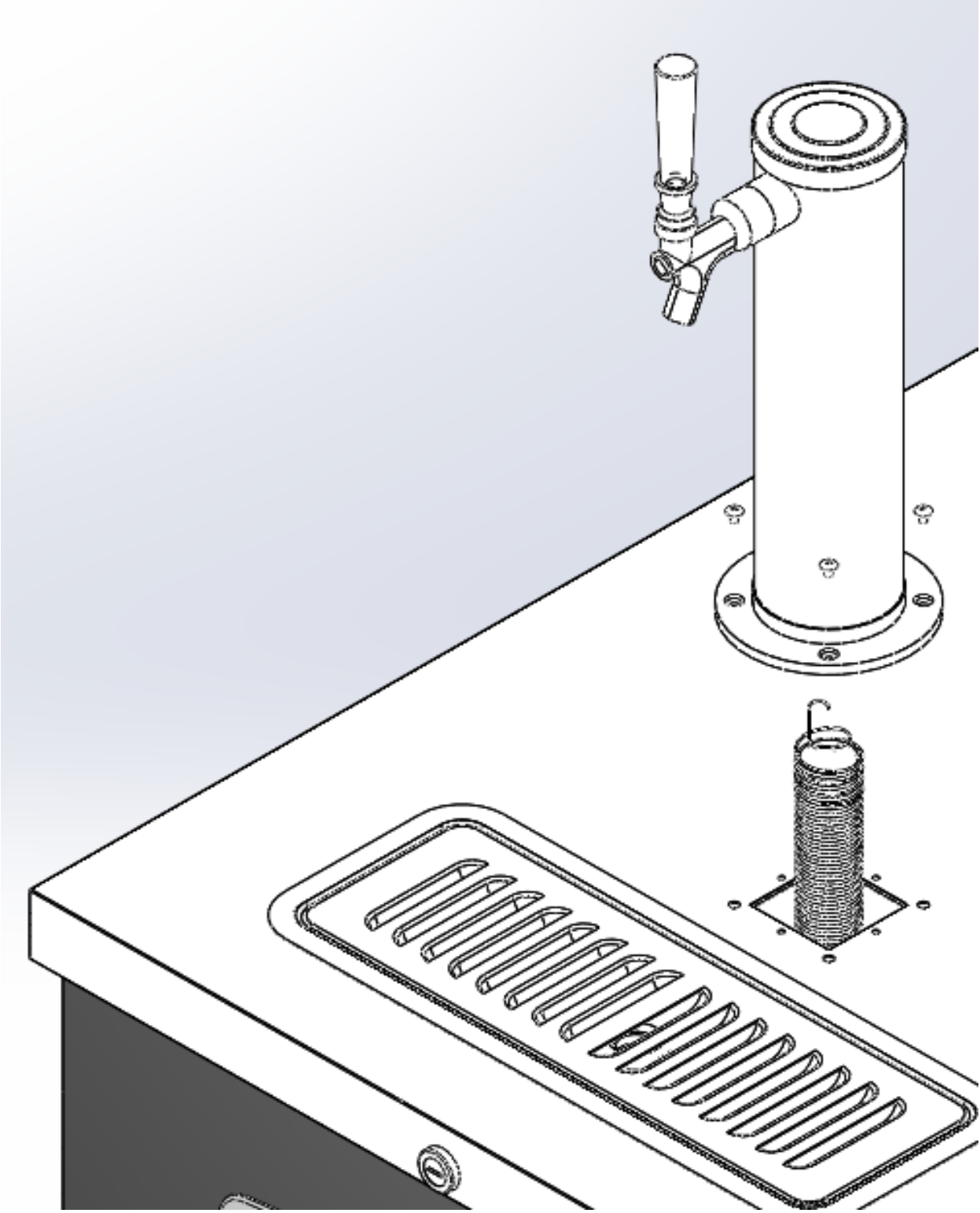

BEER LINE & CO₂ LINE INSTALLATION SCHEMATIC DIAGRAM

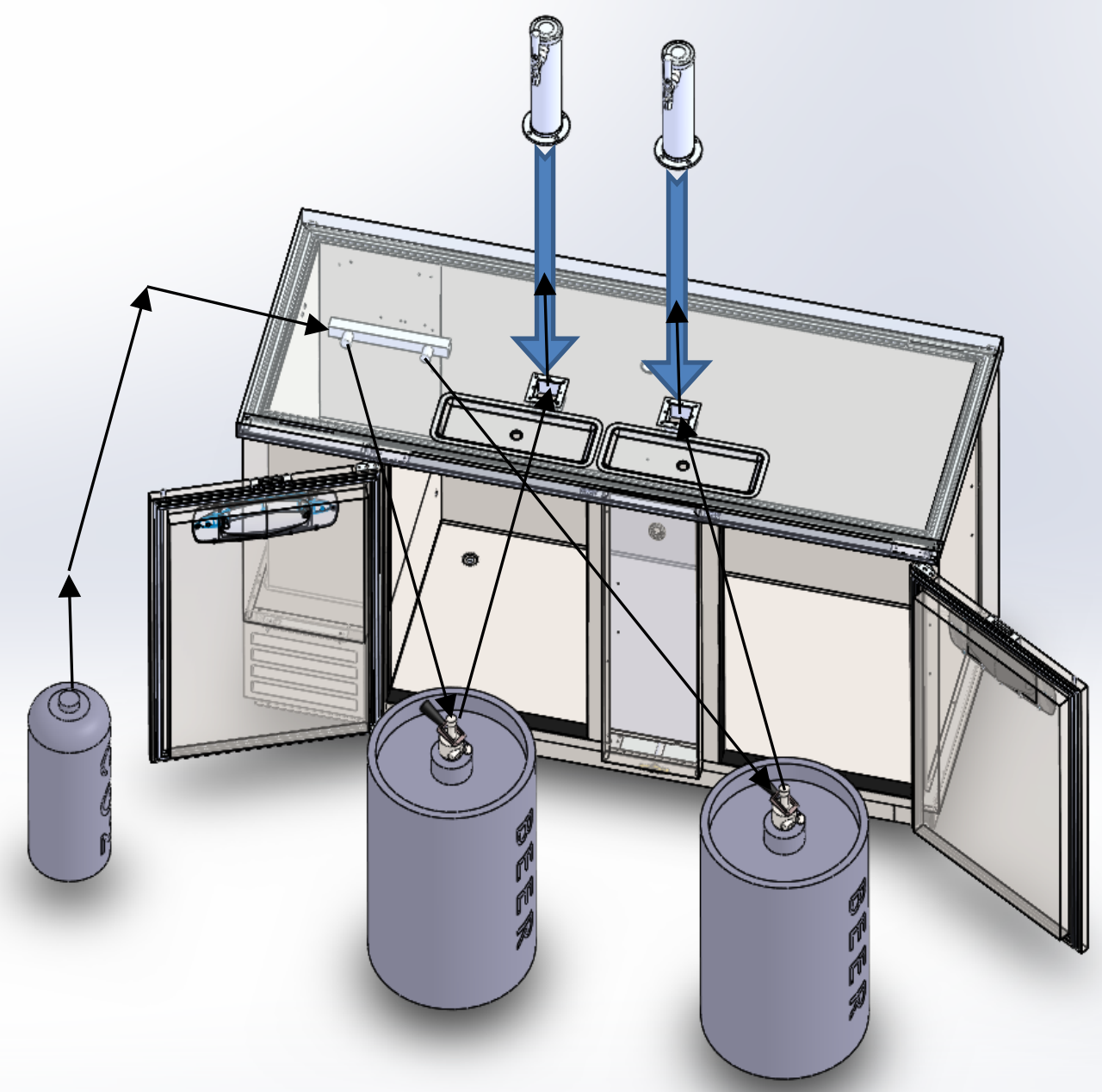

◆ Assemble Beer Line & CO₂ Line as above drawing.

DD24 WIRING DIAGRAM

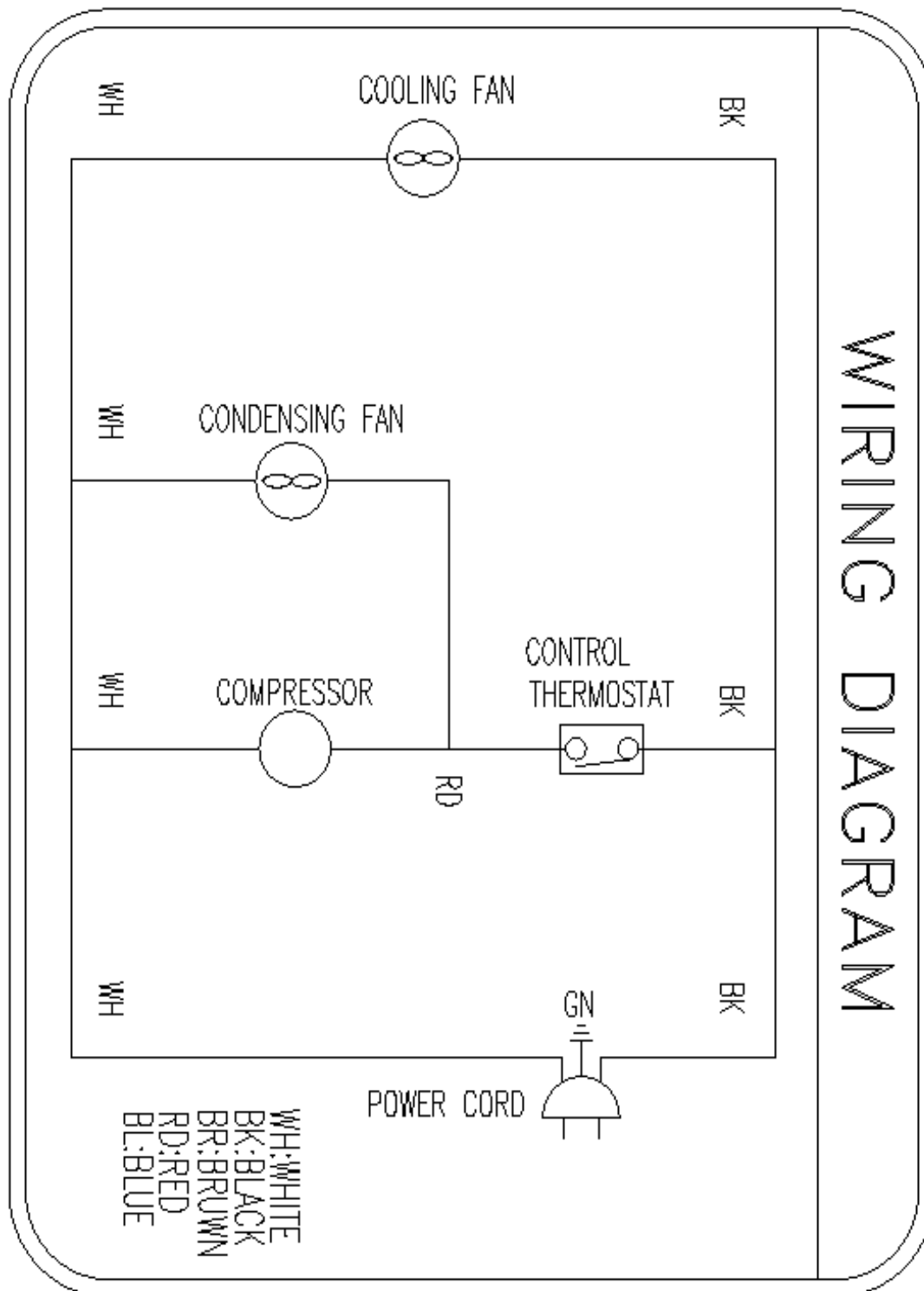

DD59, DD69, DD79, DD95 WIRING DIAGRAM

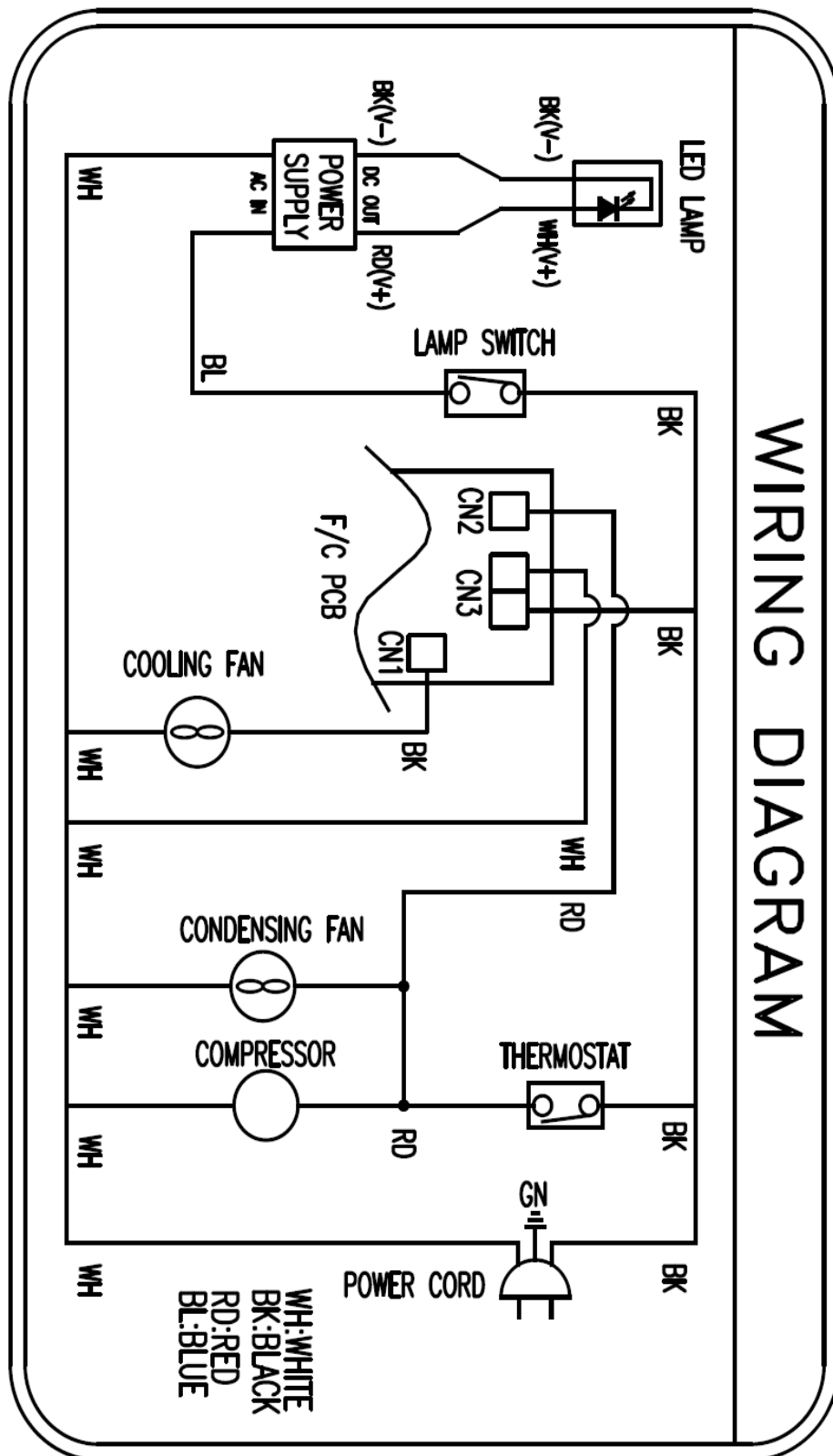

DD24 PARTS DIAGRAM

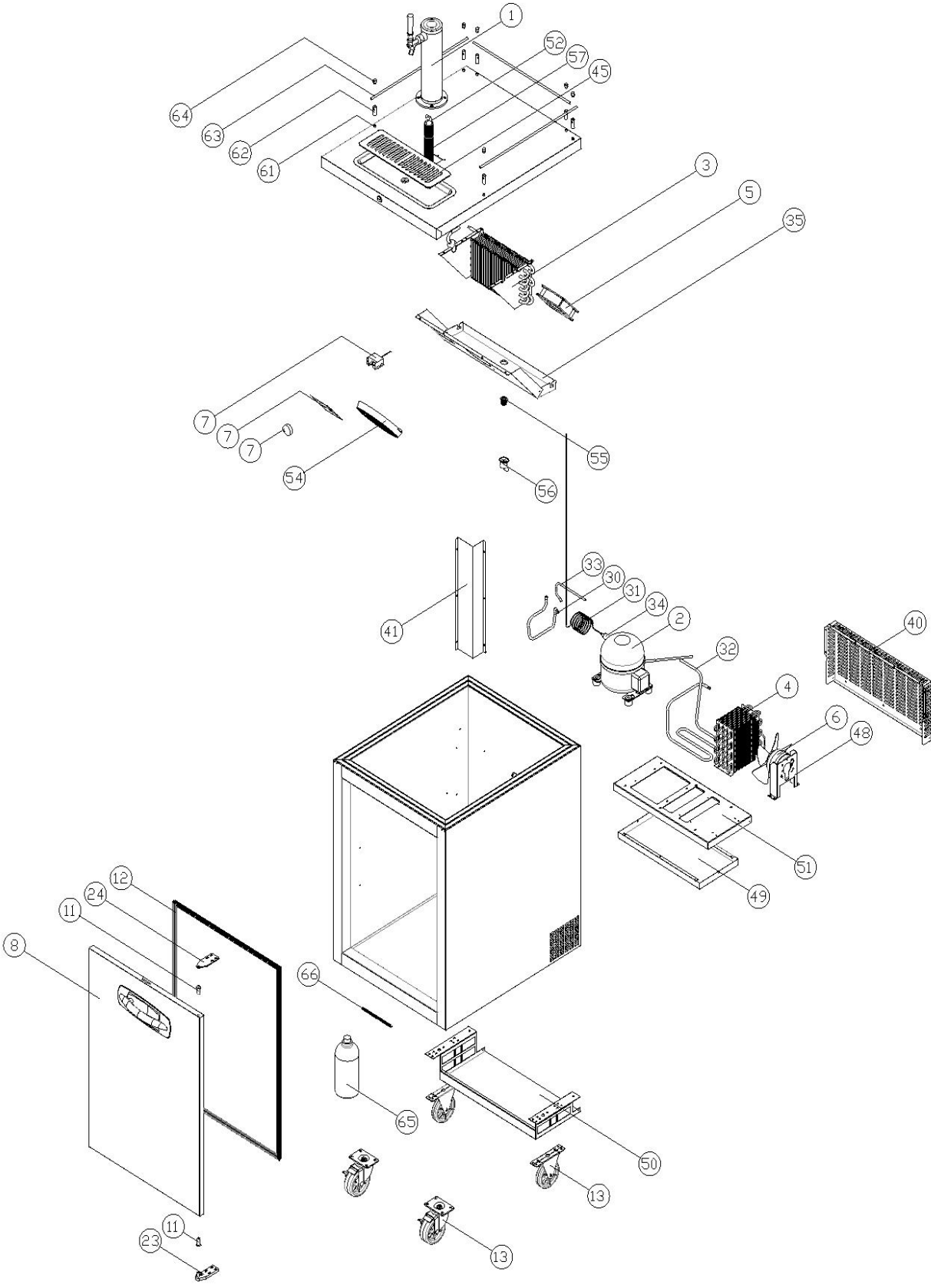

DD59 PARTS DIAGRAM

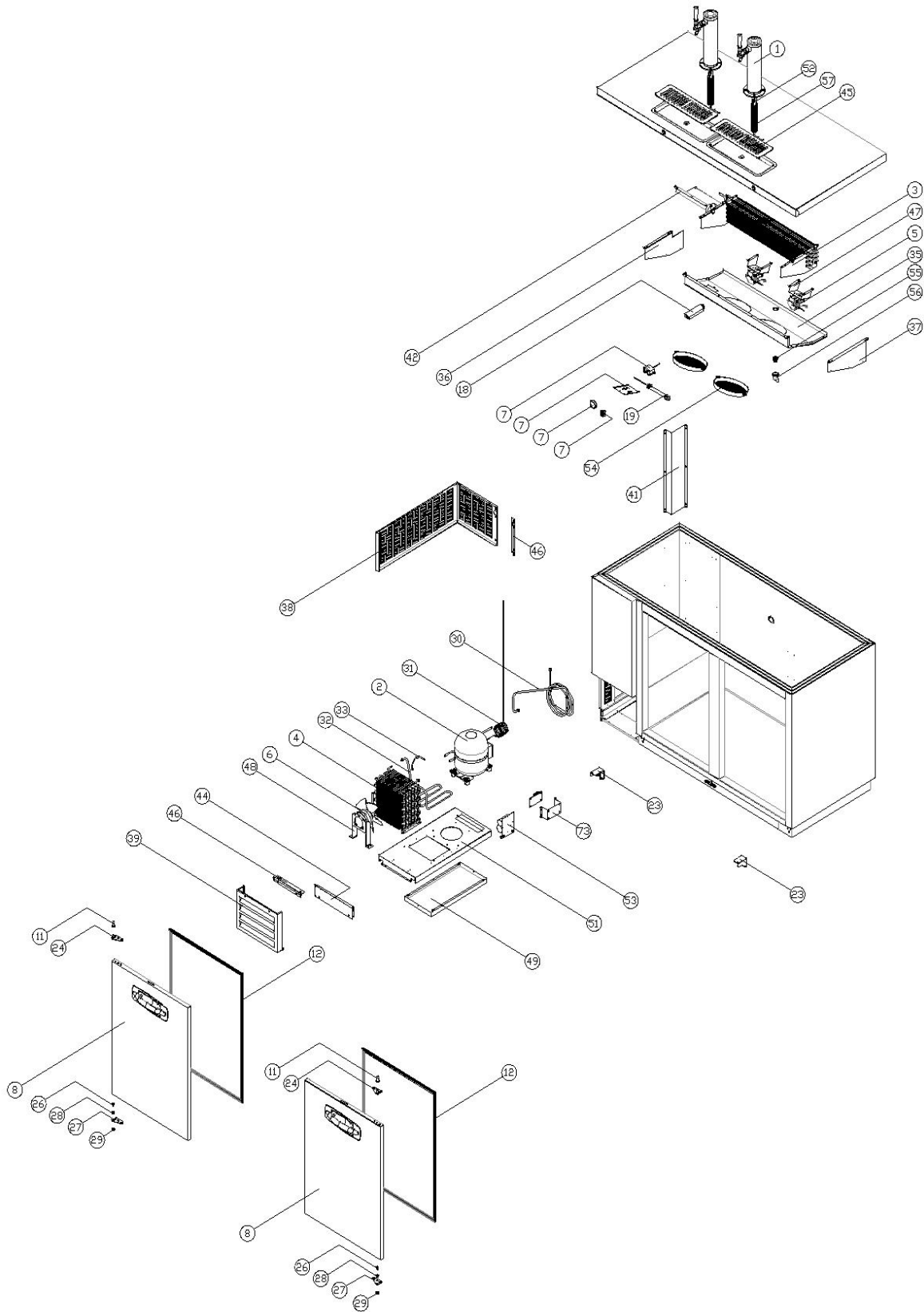

DD69 PARTS DIAGRAM

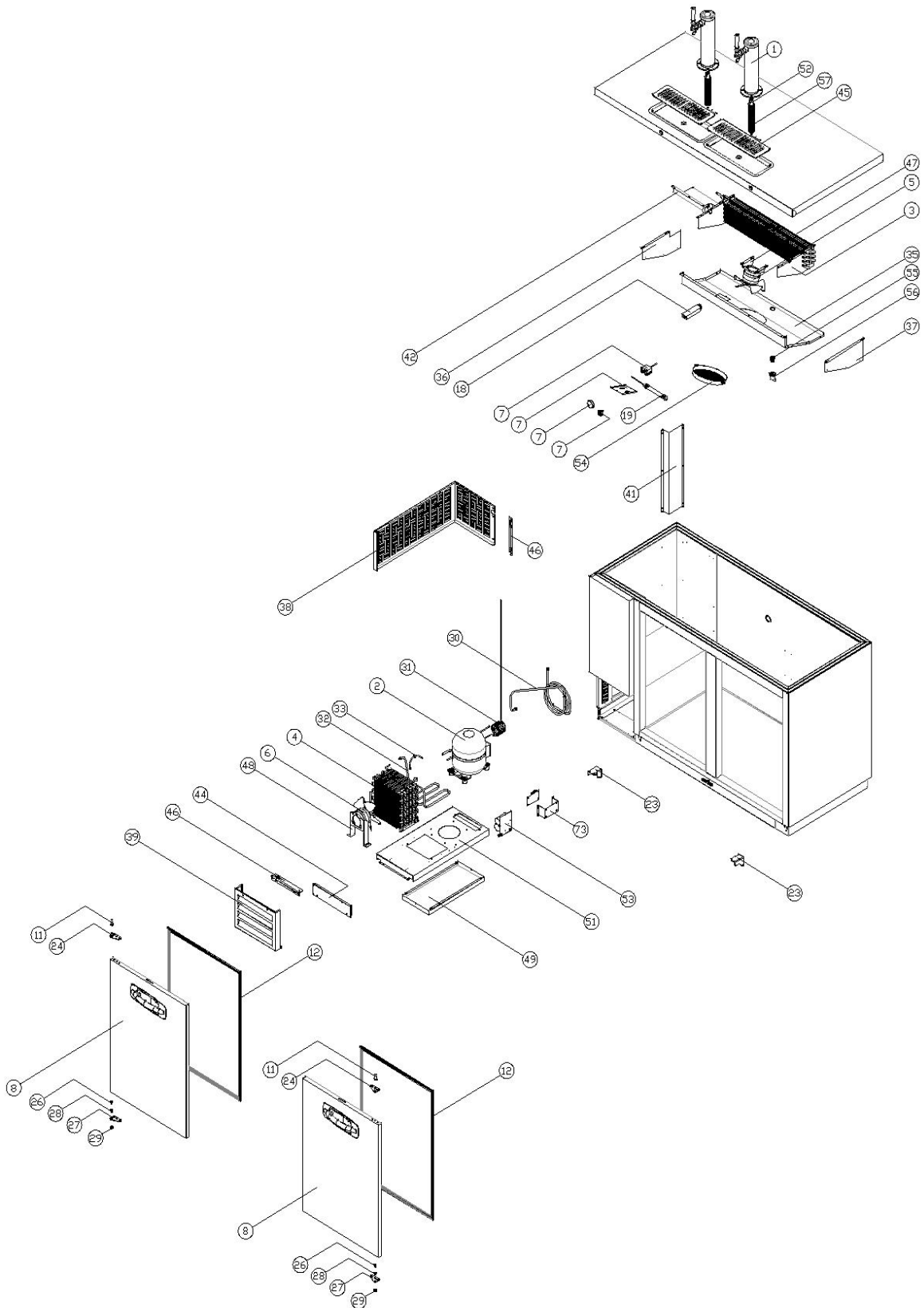

DD79, DD95 PARTS DIAGRAM

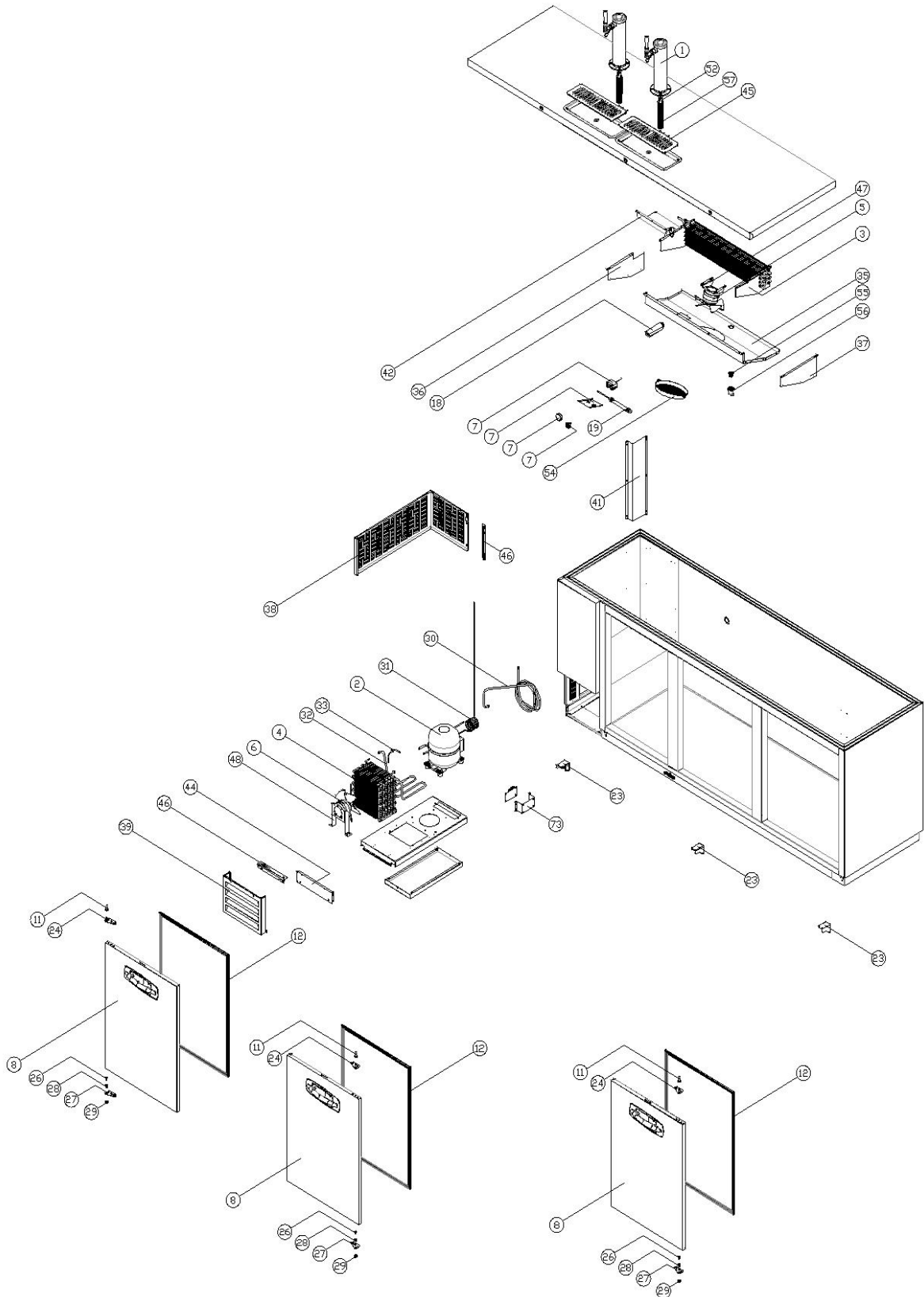

DD SERIES PARTS LIST

ITEM NO.	PART NAME and DESCRIPTION	DD24	DD59	DD69	DD79	DD95	PART NO.
1	TOWER ASSY (SINGLE)	X	2	2	X		150266
	TOWER ASSY (DOUBLE)				X	2	150267
2	COMPRESSOR (R134a UNITS) SD162C-L1U	X	X				145735
	COMP ELECTRONIC KIT (R134a UNITS)	X	X				150445
	COMPRESSOR (R134a UNITS) SK182C-L2U			X	X		160624
	COMP ELECTRONIC KIT (R134a UNITS)			X	X		160625
	COMPRESSOR (R134a UNITS) SK1A1C-L2W					X	150311
	COMP ELECTRONIC KIT (R134a UNITS)					X	150312
	COMPRESSOR (R290 UNITS)	X					161778
	COMP ELECTRONIC KIT (R290 UNITS)	X					161779
	COMPRESSOR (R290 UNITS)		X	X	X	X	161767
COMP ELECTRONIC KIT (R290 UNITS)		X	X	X	X	161768	
3	Evaporator (R134a UNITS)	X					159229
	Evaporator (R290 UNITS)	X					161854
	Evaporator (R134a UNITS)		X				157129
	Evaporator (R290 UNITS)		X				161855
	Evaporator (R134a UNITS)			X	X	X	157130
	Evaporator (R290 UNITS)			X	X	X	161856
4	Condenser	X					159232
	Condenser		X	X	X	X	157131
5	EVAPORATOR FAN MOTOR		2				145709
	EVAPORATOR FAN BLADE		2				145710
	EVAPORATOR FAN MOTOR			X	X	X	157132
	EVAPORATOR FAN BLADE			X	X	X	145750
	EVAPORATOR FAN MOTOR	X					157133
6	CONDENSER FAN MOTOR (R290 UNITS)	X					161858
	CONDENSER FAN MOTOR	X	X	X	X	X	145748
	CONDENSER FAN BLADE	X					145750
	CONDENSER FAN BLADE		X	X	X	X	145749
7	THERMOSTAT CONTROL (R134a UNITS)	X	X	X	X	X	160640
	THERMOSTAT CONTROL (R290 UNITS)		X	X	X	X	161859
	THERMOSTAT PLATE	X	X	X	X	X	145822
	THERMOSTAT KNOB	X	X	X	X	X	145730
	LAMP SWITCH (R134a UNITS)	X	X	X	X	X	145729
	LAMP SWITCH (R290 UNITS)	X	X	X	X	X	161771
9	DOOR ASSY 24	X					159234
	DOOR ASSY LEFT		X	X	X	X	157571
	DOOR ASSY RIGHT		X	X	X	2	157572
	DOOR ASSY RIGHT (CENTER DOOR ON BB79)				X		157573
11	DOOR BUSHING	X					159220
12	DOOR GASKET	X	2	2	2	3	157574
	DOOR GASKET (CENTER DOOR ON BB79)				X		157575
13	CASTER SET	X					159240
18	LED DRIVER	X	X	X	X	X	157576
19	LED LAMP (462mm)	X	X	X	X	X	157577
23	HINGE BOTTOM LEFT		X	X	X	X	157583

	HINGE BOTTOM RIGHT		X	X	2	2	157584
	HINGE BOTTOM	X					145684
24	HINGE TOP	X					159226
	HINGE TOP LEFT		X	X	X	X	157585
	HINGE TOP RIGHT		X	X	2	2	157586
26	HINGE BOLT		2	2	3	3	157588
27	HINGE TOP CONNECTOR		2	2	3	3	157589
28	BOTTOM HINGE SHAFT		X	X	X	X	159227
29	HINGE BUSHING		2	2	3	3	159228
30	SUCTION PIPE ASSY 24 (R134a UNITS)	X					159244
	SUCTION PIPE ASSY 24 (R290 UNITS)	X					
	SUCTION PIPE ASSY (R134a UNITS)		X	X	X	X	157590
	SUCTION PIPE ASSY (R290 UNITS)		X	X	X	X	161866
31	CAPILLARY TUBE 24 (R134a UNITS)	X					145725
	CAPILLARY TUBE 24 (R290 UNITS)	X					
	CAPILLARY TUBE (R134a UNITS)		X	X	X	X	157591
	CAPILLARY TUBE (R290 UNITS)		X	X	X	X	
32	HOT PIPE 24 (R134a UNITS)	X					159245
	HOT PIPE (R134a UNITS)	X	X	X	X	X	157592
33	SUCTION JOIN PIPE 24 (R134a UNITS)	X					159246
	SUCTION JOIN PIPE 24 (R290 UNITS)	X					
	SUCTION JOIN PIPE (R134a UNITS)		X	X	X	X	157593
	SUCTION JOIN PIPE (R290 UNITS)		X	X	X	X	
34	DRYER (R134a UNITS)	X	X	X	X	X	145714
	DRYER (R290 UNITS)		X	X	X	X	161783
35	DUCT 24D	X					160632
	DUCT 59		X				160629
	DUCT 69,79,95			X	X	X	160630
36	DUCT LEFT COVER		X	X	X	X	159248
37	DUCT RIGHT COVER		X	X	X	X	159249
38	SIDE PANEL		X	X	X	X	160934
39	FRONT PANEL		X	X	X	X	157600
40	BACK PANEL	X					159252
41	PIPE COVER 24	X					159253
	PIPE COVER 59,69,79,95		X	X	X	X	157601
42	HARNESS & PIPE COVER		X				157602
	HARNESS & PIPE COVER			X			157603
	HARNESS & PIPE COVER				X		157604
	HARNESS & PIPE COVER					X	157605
43	LED HARNESS COVER 24	X					159256
	LED HARNESS COVER 59,69,79,95		X	X	X	X	157606
44	CABINET BASE		X	X	X	X	157607
45	BEER GRILL	X	2	2	2	2	159257
51	COMPRESSOR BASE	X					159258
	COMPRESSOR BASE		X	X	X	X	157608
52	HOSE HOLDER	X	2	2	2	2	159260
54	EVAP FAN COVER	X	2	X	X	X	157609
55	EVAP DRAIN ELBOW A	X	X	X	X	X	157684
56	EVAP DRAIN ELBOW B	X	X	X	X	X	157685
57	AIR HOSE	X	2	2	2	2	159264

58	MAIN HARNESS 24 (R134a UNITS) NOT SHOWN	X					160633
	MAIN HARNESS 24 (R290 UNITS) NOT SHOWN	X					161860
	MAIN HARNESS 59 (R134a UNITS) NOT SHOWN		X				157612
	MAIN HARNESS 59 (R290 UNITS) NOT SHOWN		X				161861
	MAIN HARNESS 69 (R134a UNITS) NOT SHOWN			X			160628
	MAIN HARNESS 69 (R290 UNITS) NOT SHOWN			X			161862
	MAIN HARNESS 79, 95 (R134a UNITS) NOT SHOWN				X	X	157613
	MAIN HARNESS 79, 95 (R290 UNITS) NOT SHOWN				X	X	161863
59	COMPRESSOR HARNESS (R134a UNITS) NOT SHOWN	X					159302
	COMPRESSOR HARNESS (R290 UNITS) NOT SHOWN	X					161864
	COMPRESSOR HARNESS (R134a UNITS) NOT SHOWN		X	X	X	X	157614
	COMPRESSOR HARNESS (R290 UNITS) NOT SHOWN		X	X	X	X	161865
60	POWER CORD NOT SHOWN	X	X	X	X	X	145733
61	BASE BOLT	6					160634
62	GUIDE BASE	6					160635
63	TOP GUIDE	3					160636
64	TOP BOLT	6					160637
65	BOTTLE	1					160638
66	CO2 SPRING	1					160639
67	CASTERS (4) 2 LOCKING & 2 NON-LOCKING PLATE TYPE		X				160620
	CASTERS (6) 3 LOCKING & 3 NON-LOCKING PLATE TYPE			X	X	X	160621
70	DOOR LOCK KEY	1	2	2	3	3	160743
73	FAN CONTROL PCB KIT	X	X	X	X	X	161579