



# MARKET FORGE

## **ST-E STEAM IT COUNTERTOP ELECTRIC PRESSURE COOKER PARTS AND SERVICE MANUAL**

**EFFECTIVE SEPTEMBER 5, 2018**

Superseding All Previous Parts Lists.

The Company reserves the right to make substitution in the event that items specified are not available.

ERRORS: Descriptive and/or typographic errors are subject to correction.

---

**MARKET FORGE**

Telephone: (802) 658-6600 Fax: (802) 860-3732

[www.marketforge.com](http://www.marketforge.com)

*P/N 14-0303 Rev D*

# TABLE OF CONTENTS

TROUBLESHOOTING.....	3
ADJUSTMENTS & PARTS REPLACEMENT.....	4
WIRING DIAGRAM.....	10
<b>ILLUSTRATED PARTS LIST</b>	
MASTER STEAM-IT ILLUSTRATION .....	15
FULCRUM & DRAIN ASSEMBLY .....	18
EXHAUST VALVE .....	20
DOOR HANDLE ASSEMBLY.....	22
DOOR ASSEMBLY .....	23
STAND ASSEMBLY - OPTIONAL STEAM-IT STAND.....	24
CABINET ASSEMBLY .....	25

# TROUBLESHOOTING

## TROUBLE TESTS & REMEDIES

### Timer

If the timer should fail to operate the Steam-It and a check shows all wiring to be in good order, and should the timer control switch be found in good order as ascertained by a continuity check, the timer must be regarded as defective and must be replaced. The timer is replaceable on as a complete unit.

### Steam Trap

The first indication of a defective steam trap operation will usually be evidence by uneven cooking. If working properly, the steam temperature will be even and cooking will be uniform through the cooking compartment. Trouble may occur either through premature closing of the steam trap before all the cold air has exhausted or by its failure to close sufficiently to enable a proper steam pressure build-up. Either case warrants the replacement of the steam trap.

POSSIBLE CAUSE	CORRECTION
<b>STEAM-IT FAILS TO OPERATE AT ALL (NO PRESSURE BUILD-UP).</b>	
<ol style="list-style-type: none"> <li>1. Blown fuse.</li> <li>2. Wiring is defective.</li> <li>3. Not installed correctly.</li> <li>4. Element control switch or contactor coil not in circuit.</li> <li>5. Current not passing through timer to start unit.</li> </ol>	<ol style="list-style-type: none"> <li>1. Replace fuse. If it blows again, check that source of electric supply is 60 Amps.</li> <li>2. Check all wiring. Repair or replace.</li> <li>3. Check wiring diagram for correct hookup.</li> <li>4. Check both element control switch and contactor coil for continuity. Repair or replace either if found defective.</li> <li>5. Check timer for continuity of primary circuit thru timer control switch.</li> </ol>
<b>STEAM-IT OPERATES, BUT FAILS TO BUILD-UP PRESSURE TO 14 LBS. PRESSURE.</b>	
<ol style="list-style-type: none"> <li>1. Steam trap fails to properly close.</li> <li>2. Exhaust valve fails to hold pressure at 14 lbs.</li> <li>3. Steam leaks around door.</li> <li>4. Safety valve blows off below 15 lbs. pressure.</li> <li>5. Element control switch not properly adjusted.</li> </ol>	<ol style="list-style-type: none"> <li>1. Replace steam trap.</li> <li>2. Check for correct adjustment or strip down, clean and repair.</li> <li>3. Clean seating surfaces and gasket to make sure they are free of food particles. Check for worn gasket or make door adjustment.</li> <li>4. Replace safety valve.</li> <li>5. Readjust.</li> </ol>
<b>UNIT RELEASES PRESSURE BEFORE COOKING CYCLE HAS TERMINATED ON TIMER.</b>	
<ol style="list-style-type: none"> <li>1. Power loss.</li> <li>2. Low water cut-off has functioned prematurely.</li> </ol>	<ol style="list-style-type: none"> <li>1. Check for disruption at source of electric supply.</li> <li>2. Adjust or replace low water cut-off.</li> </ol>
<b>TIMER DOES NOT FUNCTION AT 10 PSI OF CYLINDER PRESSURE TO START COUNTDOWN.</b>	
<ol style="list-style-type: none"> <li>1. Loose or broken electrical leads to the timer or timer control switch.</li> <li>2. Timer motor defective.</li> <li>3. Timer control switch defective or out of adjustment.</li> </ol>	<ol style="list-style-type: none"> <li>1. Repair or replace defective wiring.</li> <li>2. Check timer motor for continuity. Replace complete timer if found defective.</li> <li>3. Make continuity check, adjust, replace if necessary.</li> </ol>
<b>UNEVEN COOKING</b>	
<ol style="list-style-type: none"> <li>1. Steam trap closing prematurely preventing removal of air from the cooking chamber.</li> </ol>	<ol style="list-style-type: none"> <li>1. Replace the steam trap.</li> </ol>
<b>HEATING ELEMENTS CUTTING OUT BEFORE 13 LBS. PRESSURE IS REACHED.</b>	
<ol style="list-style-type: none"> <li>1. Pressure cutting off electrical at the element control switch too soon.</li> </ol>	<ol style="list-style-type: none"> <li>1. Make adjustments on the dial of the element control switch to remedy.</li> </ol>

# ADJUSTMENTS & PARTS REPLACEMENT

## NEW STYLE EXHAUST VALVE (AFTER JULY 1983)

### Replacement instructions:

Disconnect fitting pressure gauge. Remove flue enclosure. Remove old exhaust by unscrewing 1/4 IPS nipple from cylinder. Remove safety relief valve assembly from 1/2 IPS nipple. Remove all fittings from the reducing tee and remove tee and nipple by unscrewing nipple from cylinder, remount nipple and tee in the front 1/4 IPS tap hole. (Note that the use of the rear 1/4 IPS tap hole is eliminated, install plug as show on page 26). Mount new exhaust valve assembly onto 1/2 IPS nipple previously used to mount safety relief valve (before mounting exhaust valve assembly, install heat deflector plate on valve as shown on page 26). Reconnect 1/4 OD tubing (steam pressure line) as shown on page 0. Remount flue enclosure. Install all new fittings, tubing and wire joints.

**NOTE:** All parts shown potted are existing to be reused with new assembly. All items (except ref. items) and one print of this drawing to be included with this kit #10 to be used for shipping.

## ELEMENT CONTROL SWITCH

The element control switch located under the removable front lower panel, just left of center, governs the flow of current to the heating elements to maintain cylinder pressures at a near constant 14 PSI.

A copper tube extending from the top of the cylinder to the rear position of the element control switch constantly reflects internal cylinder steam pressure upon the built-in bellows of the element control switch to cause it to open or close and electrical circuit to the contactor coil. With little or no pressure applied to the bellows, the circuit to the contactor will be closed and providing the timer is set to cycle, the contactor will click in and current will flow to the heating elements. When the pressure rises to 14 PSI (original factory setting), the bellows will be sufficiently compressed by the steam back-pressure to break the circuit to the contactor coil, the contactor will click out and current flow to the heating elements will cease. When cooling allows the pressure to drop below 13 lbs., the bellows will again complete the contactor coil circuit, activate the contactor to click in and allow the heating elements to energize. Thus, by working intermittently to open and close the contactor coil circuit, the element control switch, in effect, regulates current flow to the heating elements.

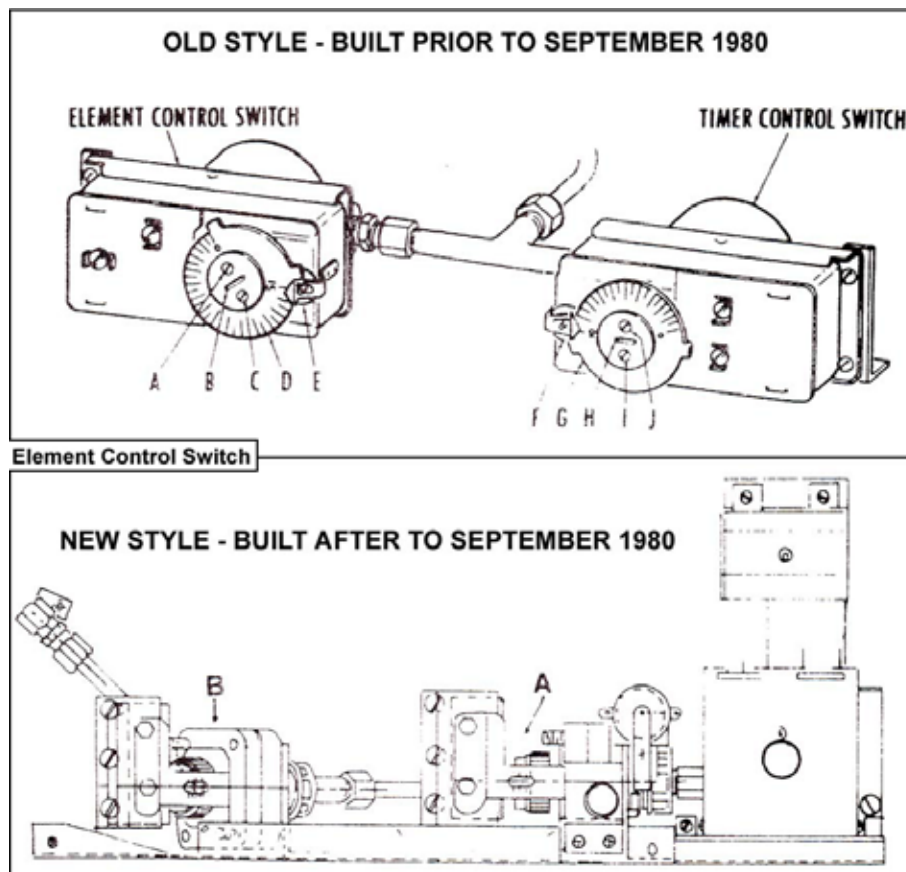

# ADJUSTMENTS & PARTS REPLACEMENT

## Dial Adjustment

Two dial settings determine the operational range of the element control switch. The larger dial (D) determines the maximum build-up of cylinder steam pressure while the smaller dial (E) governs the range of differential between the switches cut-in and cut-off points. Should a lower cylinder cooking pressure be desired, adjust the large dial (D) by inserting a screwdriver onto the slot (B) found at the center and turning it slightly counterclockwise to lower the pressure. Clockwise rotation will increase the pressure.

Pressure must not be adjusted to exceed 14 lbs. as the safety valve is set to automatically open just above this point. The cut-in and cut-off points of the element control switch may be adjusted by rotating the small screw at the center of the smaller dial (E). Normal factory setting is for a one pound differential between cut-in and cut-off. To increase the range of differential, rotate the screw counterclockwise.

Check adjustments through a trial cycle by observing pressure gauge reading when it clicks in after cylinder cooking. The differential in pressure as read on the pressure gauge should at these points be approximately one pound.

## Recalibrating

The element control switch may be recalibrated should it vary somewhat through usage from its original factory setting.

At the precise moment of contactor "clicked-out", the dial setting of the element control switch and the steam pressure gauge reading should both be 14 lbs. A slight override of steam pressure build-up will normally occur and indicate itself on the pressure gauge after the contactor has "clicked-out". This is normal and it not to be interpreted as an element control switch out of calibration.

## PRESSURE CONTROL SWITCH

(Formally known as the element control switch)

NOTE: *Models built after September 1980 use 2 Barksdale Pressure Switches in place of the White-Rodgers Element Control Switch and Timer Control Switch.*

## Operating Pressure Adjustment

The operating pressure is determined by setting the right switch (A) at approximately 10 PSI and the left switch (B) at approximately 14 PSI. Both switches were set At the factory. These settings can be verified by looking through the slot (*in the red rectangle*) and observing the alignment of the black line inside with the white scales on either side of the slot. To readjust, turn the white knurled knob in appropriate direction to raise or lower pressure.



## WARNING

**Because power must be on to adjust pressure switches, be sure to protect against electrical shock. Check adjustments through a trial cycle and observe pressure readings on pressure gauge when switch (B) clicks off at maximum cylinder pressure and when switch (A) clicks on after cylinder cooking. Making adjustments are needed, being careful not to let switch (B) pressure be set to exceed 14 lbs. Since the safety valve is set to automatically open just above this point.**

## Recalibrating Pressure Control Switch

The actuation valve (*differential*) is factory set and cannot be recalibrated.

## CLEANING EXHAUST SILENCER

The exhaust silencer should be removed and cleaned periodically. As the cooking chamber is exhausted of steam through the silencer, impurities can build up from food particles. Cleaning should be frequent enough to prevent clogging to occur. For this reason, the exhaust silencer is made easily accessible and simple to remove. To clean:

1. Remove the one piece exhaust silencer from the unit by unscrewing it in a counterclockwise direction.
2. Clean the silencer by sloshing it in hot soapy water and rinse it in clear water. If dirt has clogged the silencer, presoak it in alkaline cleaning solution.
3. After cleaning, stand the silencer on edge to allow it to drain.
4. Screw it back into the elbow of the exhaust valve clockwise.

# ADJUSTMENTS & PARTS REPLACEMENT

## LOW WATER CUT-OFF

The low water cut-off is mounted above the timer assembly under the front lower panel with its thermostat bulb extending and inserting into a channel provided for it at the outer edge of the cast-in heating elements. It functions as a safety feature to shut off the complete unit in the event the water runs dry.

If the steam-it operated with no water or the water has evaporated away, the temperature of the cooking cylinder will rise and by heat inductions effect the thermostat bulb of the low water cut-off. Electric current flow will be broken at the low water cut-off and the unit will shut down. With the replacement of water into the cooking cylinder, the thermostat bulb will be cooled and the unit will then again be operative after the reset button has been pressed. If the unit does not start after pressing the reset button, more time will have to be allowed for further cooling.

*NOTE: Should a cooking cycle be started with insufficient water and interrupted due to safety action of the low water cut-off, the food in the process of cooking will be affected. Proper compensation will have to be made for the cooking performed and with proper amount of water in the cooking cylinder, a new cycle determined and set to complete the process.*

## TIMER CONTROL SWITCH

The timer control switch located under the removable front lower panel just right of center, automatically delays the timer count-down at the beginning of the cycle until the Steam-It has fully free-vented out all the cold air from within the cooking cylinder and pressure has reached 10 PSI. This delay insures the timer to count only that portion of the cycle when cylinder steam pressure is actually acting on the foods. This, of course, is important when processing foods which only require very short periods of cooking time.

The copper tube which extends from the top of the cylinder to the rear portion of the timer control switch constantly reflects internal cylinder steam pressure upon the timer control switches build-up bellows. While cylinder free-venting is occurring the switch keeps the timer circuit open. After free-venting has terminated and when the cylinder pressure has built up to approximately 10 PSI, the contacts will be forced closed by back-pressures working on the bellows, the timer circuit will be completed and the timer will then start its countdown.

### Adjustments

The cut-in point of the timer control switch has been factory set at its maximum setting of 10 lbs., and should not be altered unless its found that the timer does not start until

well after 10 lbs. of steam pressure has been realized on the pressure gauge. In this case, insert a screw driver into the center slot (H) of the larger dial (G) and rotate slightly counterclockwise to adjust timer to start at 10 PSI.

### Recalibrating

Should the timer control switch vary through usage from its original factory setting, it may be restored to proper working order by recalibrating. A visual check of the timer control switch during a trial cycle will quickly determine the need of recalibration. With the timer control switch dial set at 10 lbs., (*fully clockwise*) the timer motor should cut-in when 10 lbs. of steam pressure is registered on the steam pressure gauge. By watching the smaller dial (F) on the timer control switch, the cut-in of the switch may be observed and heard to click forward at the moment the circuit is made to the timer motor. At that precise moment the pressure gauge should read 10 lbs.

1. Set the larger dial (G) of the timer control switch to 10 lbs., (*fully clockwise*).
2. Loosen the two screws (I) and (J) located on either side of the dial slot (H).
3. First, note the position of the slot (H) in relation to
4. the dial (G). then while holding the dial stationary, insert a screwdriver into the slot and rotate slightly to adjust (*Clockwise- increase pressure, counterclockwise-decrease pressure*). Tighten the two screws (I) and (J) to hold this adjustment.
5. Check the unit through a trial cycle and note the pressure gauge reading when the timer control switch is observed and heard to click forward. Pressure reading should then be at 10 lbs., (*check also may be made by continuity*) readjust if necessary.

### SAFETY VALVE

The safety valve is set to automatically relieve the cooking compartment of excessive pressure build-up by opening at a point between 15.5 lbs. and 16 lbs. If the safety valve should leak continually with a pressure build-up, or should it cause an interruption of the cooking cycle prematurely (*less than 15.5 lbs., on steam gauge*) it must be determined to be defective and be replaced. However, the steam gauge should first be checked for accuracy before making this determination. The steam gauge should register absolute zero setting with no pressure in the cooking cylinder. If the normal zero setting has advanced somewhat through usage (*a characteristic of steam gauges*) the amount of advancement from absolute zero must be subtracted from its registered reading to determine the true steam pressure.

# ADJUSTMENTS & PARTS REPLACEMENT

## STEAM TRAP

The steam trap is located within the flue at the top rear of the steam-it. It has the very important automatic dual function of exhausting all cold air from the cooking compartment and of making a suitable seal allow a pressure build-up of live steam during the cooking cycle. Failure of this unit to operate properly will result in uneven cooking.

## FLUE

The flue serves as a protection shield for the steam trap (B), safety valve (A), exhaust valve (D) as well as a front-facing mount for the steam gauge (E). As servicing of these parts may at times require the removal of the flue, an exploded view drawing is provided to show their proper relative positions within the flue and the method of their assembly to the cooking cylinder.

### Remove the Flue

1. Unscrew and remove exhaust silencer (F).
2. Detach the 3/16" copper tube connector (C) from the steam gauge (E) at the ferrule nearest the steam gauge. Then, remove the copper tube entirely by freeing it at the other ferrule.
3. Apply inward pressure at either sides of the flue at points (1) and (2) with a screwdriver. This will collapse the side walls slightly to allow the small fluted sections of sheet metal to clear the edges of the flue opening provided in the outer shell of the steam-it. With the restrictions of the flue removed, the flue may then be lifted up over the parts it houses.

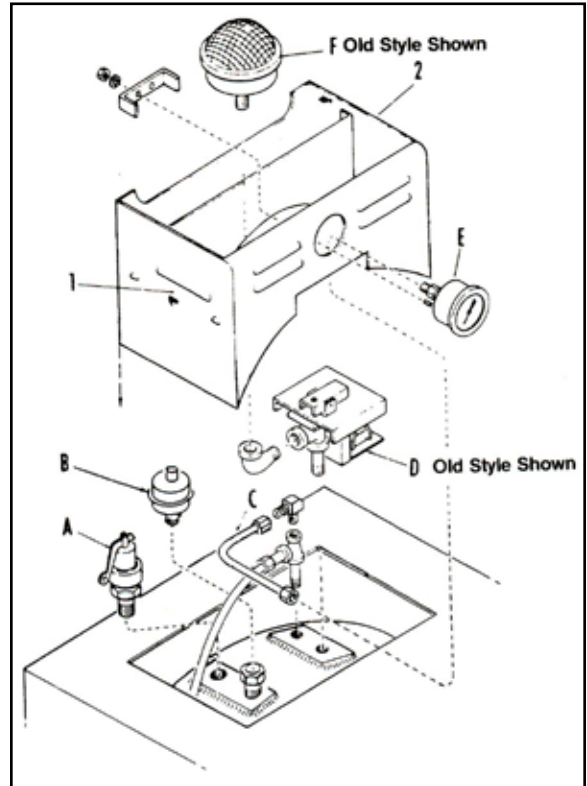

# ADJUSTMENTS & PARTS REPLACEMENT

## DOOR ADJUSTMENT

The door adjustment is located in the fulcrum casting at the base of the door opening. This adjustment employs the use of a screw and locknut. To adjust the cooker door to a tighter closed position (to prevent steam from leaking by the door gasket as pressure builds-up) its necessary to loosen the locknut and back off the screw at least one-quarter of a turn and retighten the locknut.

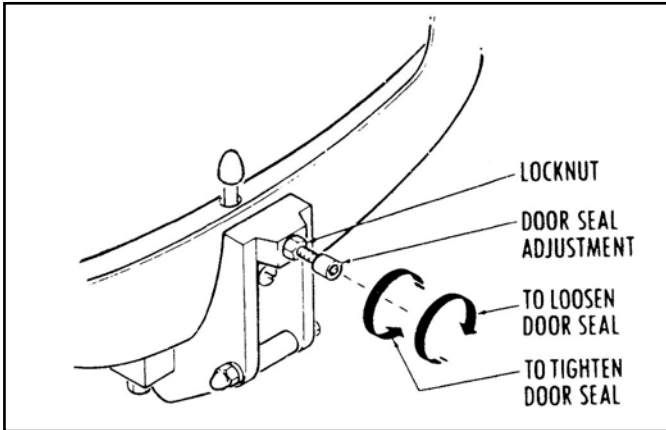

Figure 1

## Remove the Door Assembly

The door assembly can be removed from the inner cooking chamber as a unit without the use of any special tools or equipment. However, a systematic approach to this is warranted as the clearances through the portal are close and much confusion can result if not removed in the sequence described below.

1. First, lift off and remove the two pan supports to expose the door spring from each of the door spring studs. Accomplish this by counter-acting the force of the door lift spring with one hand while working the end of the door spring of the door assembly.
2. When the ends of the door spring have been completely freed from their respective door spring studs, the door lift springs on either side of the door assembly can easily be slipped off their studs.
3. When the ends of the door spring have been completely freed from their respective door spring studs, the door lift springs on either side of the door assembly can easily be slipped off their studs.
4. Rotate the entire door assembly out through the door opening, passing the door handle through the opening first, and then one end of the door spring as shown in the illustration. The remainder of the door assembly will then pass through the door opening quite easily.
5. To replace the door assembly, reverse the step by step procedure backwards.

## Door Lift Spring Replacements

Market Forge supplies replacement door lift springs in sets only. This policy has been found to be in the best interest of the customer. The lift springs are marked left and right. They must be installed properly in their marked left and right positions.

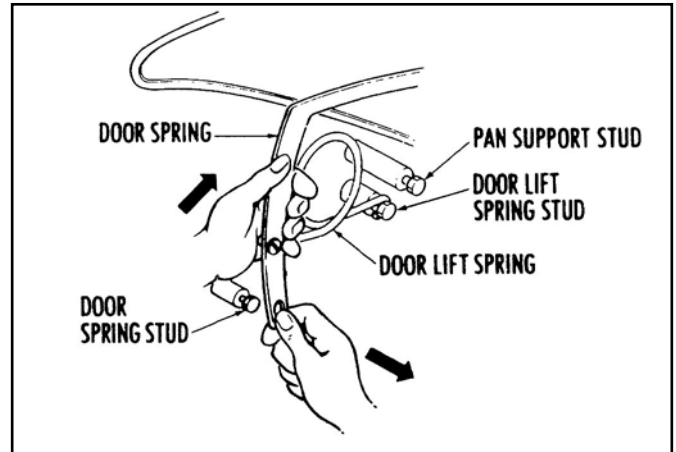

Figure 2

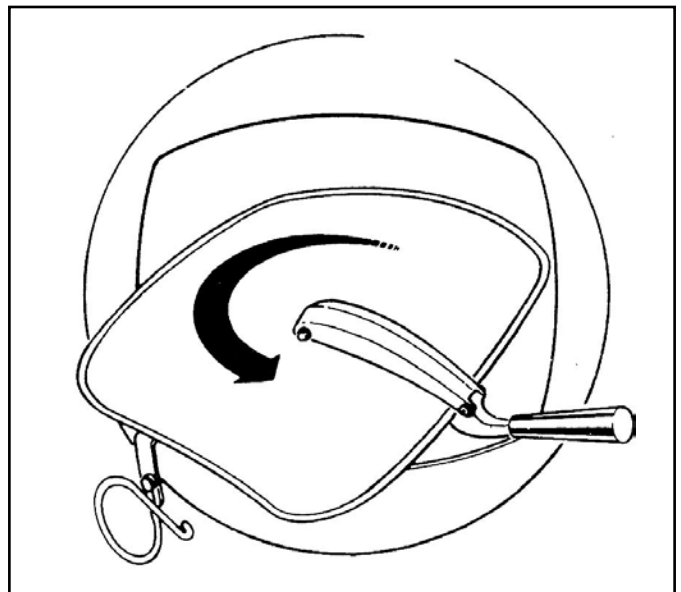

Figure 3

# ADJUSTMENTS & PARTS REPLACEMENT

## FULCRUM & DRAIN ASSEMBLY

The fulcrum and drain assembly is located at the lower front of the cooking cylinder and furnishes a sturdy anchorage for the door locking system of the door handle. Also provided in this assembly is a means of adjust for the door seal. The drain port and drain plug provide a means of discharging accumulations of water from the cooking cylinder.

## ROLLER ASSEMBLY

Built prior to 10/85 & built after 10/85. The roller assembly must be kept free-rolling at all times. Should this assembly be allowed to become frozen due to lack of lubrication, undue strain will be put on the door handle and the fulcrum casting while the door is being locked. Use only a dry lubricant such as graphite, as oil or grease will tend to attract dirt to this area.

## COOKER DOOR ASSEMBLY

The door of the cooker has been engineered to establish a positive method of sealing the steam pressure within the cooking cylinder. As steam pressure builds up within the cylinder, the door seal will tend to become more positive. However, the door should be adjusted to make a good initial seal between the door gasket and the door opening without the added assistance of internal cylinder steam pressure. With the simple action of securing the door handle down in a locked position, the door gasket should be sufficiently compressed against the door opening, all the way around, to prevent any steam leakage from occurring.

## DOOR GASKET

To change the gasket, remove the entire door assembly as a unit, remove and discard the old gasket, replace it with a new one (no cement needed) and reinstall the door assembly. Make an operation check for leaking and adjust the door if necessary.

# WIRING DIAGRAM

## COLD WATER CONDENSING UNIT

REV. C  
DRAWING NO. 17-0072

- NOTES:
- \*1. B95-0086 USED ON STERILIZER ONLY.
  - B95-0260 & 10-1017 USED ON STEAM-IT ONLY.
  2. UNIT MUST BE GROUNDED AND ALL WIRING TO COMPLY WITH LOCAL CODES.
  3. PIPE TO OPEN DRAIN. DO NOT MAKE SOLID CONNECTION TO SEWER.
  4. CONDENSING UNIT TO BE INSTALLED AS TO HAVE A BACK TO FRONT PITCH.

ITEM	PART #	DESCRIPTION	QTY
1	C95-2119	STEAM CONDENSING UNIT	1
2	C95-2219	THERMOSTAT BOX ASSEMBLY	1
3*	B95-0086	EXHAUST LINE STERILIZER	1
3*	B95-0260	EXHAUST LINE STEAM-IT	1
4*	10-1017	COMPR. ADAPTER, 3/8 IPS X 5/8 O.D.	1
5	15-7057	COPPER TUBING, 3/8 O.D.	22 1/4"
6	10-1775	RD. HD. MACH. SCREW, 1/4-20	2
7	10-2500	LOCKWASHER, 1/4	2
8	10-2308	HEX NUT, 1/4-20	2
9	10-1812	RD. HD. MACH. SCREW, 10-32	2
10	10-2505	LOCKWASHER, 10	2
11	10-2340	HEX NUT, 10-32	2
12	B95-4009	FRONT TEMPLATE (7" LONG)	1
13	B95-4010	BACK TEMPLATE (11" LONG)	1

SERVICE CONNECTIONS REQUIRED

A	1/2" I.P.S. COLD WATER CONNECTION
B	1" I.P.S. DRAIN CONNECTION (SEE NOTE 3)
C	115V ELEC. CONN. - 7/8 DIA. KNOCKOUT (COND. UNIT)
D	ELECTRICAL CONNECTION

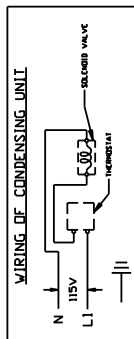

NOM. AMPS PER WIRE ■ STERILIZER

PHASE	3 PHASE	1 PHASE
VOLTS	208   236   208   236	208V (197-219) OR 240V
AMPS	1   34   31   38	53   236V (220-240)

NOM. AMPS PER WIRE ■ STEAM-IT

PHASE	3 PHASE	1 PHASE
VOLTS	208   240   440   480	208   240
AMPS	1   25   29   16	16   43   50

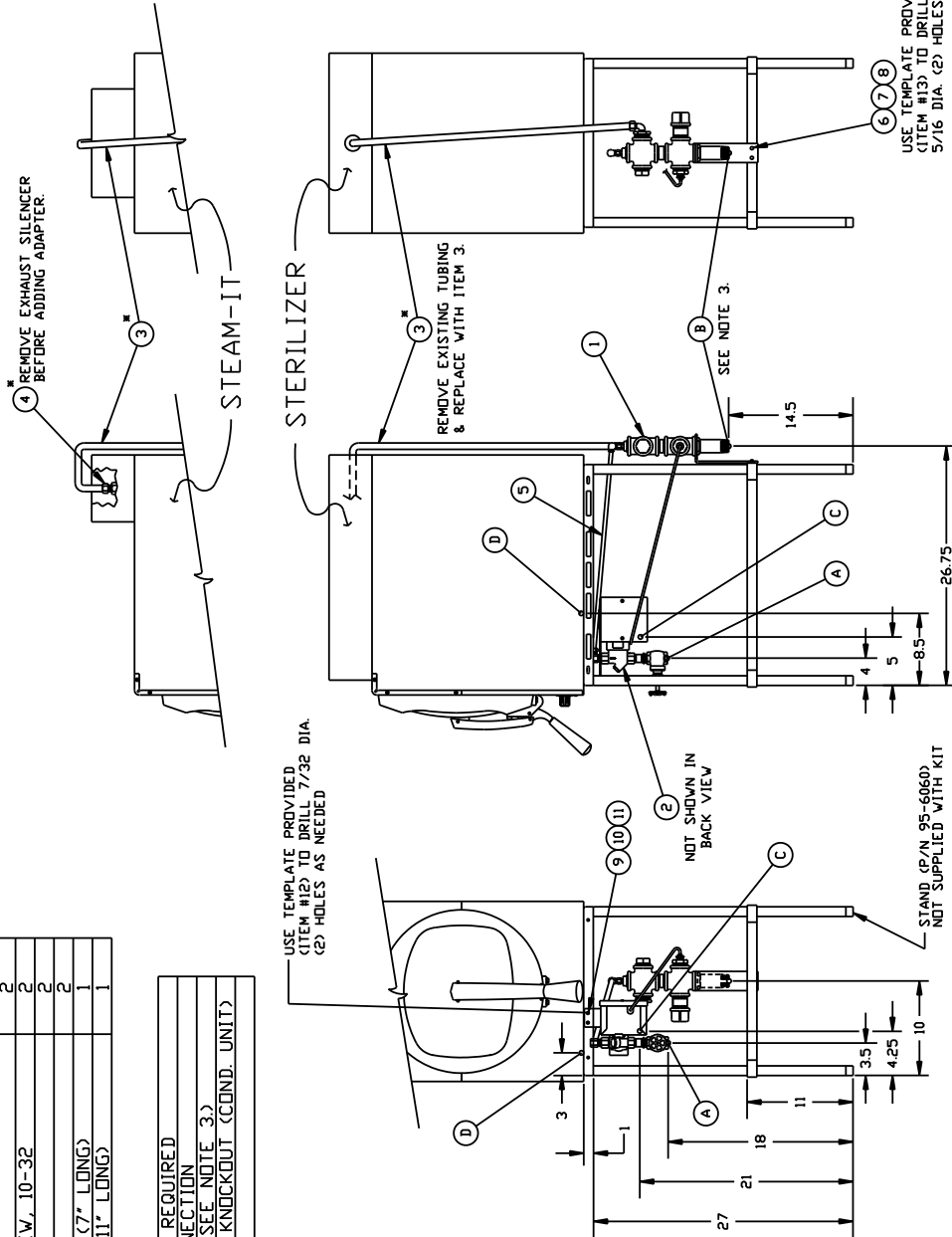

INSTALLATION INSTRUCTIONS - COLD WATER CONDENSING UNIT  
STERILIZER & STEAM-IT

A17-0072 REV. C

BY	REV./EDM#	REASON ON CAD WITH CHANGES RECORDED	DATE
C	12/21/00		

# WIRING DIAGRAM

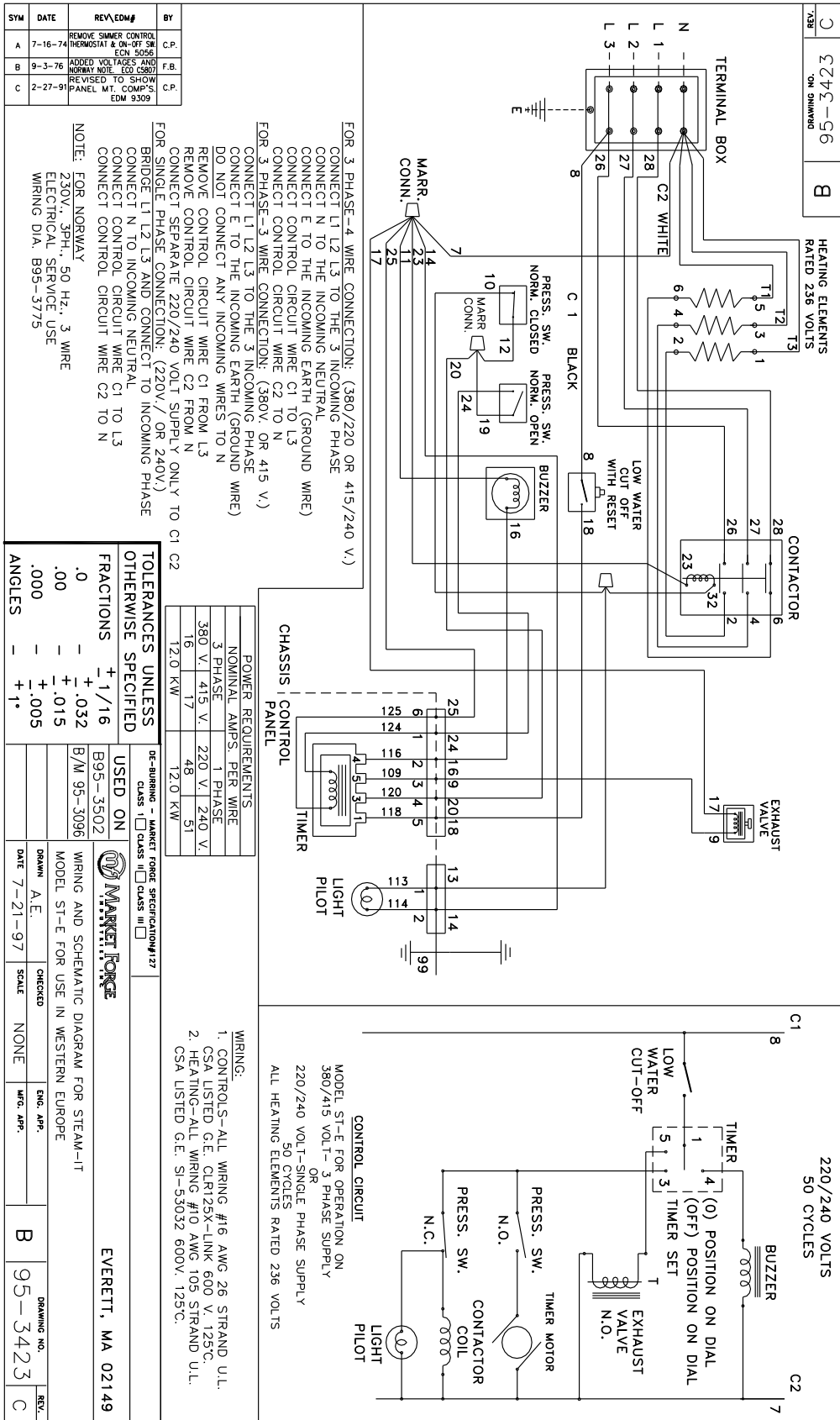

SYM	DATE	REV\EDM#	BY
A	7-16-74	REMOVE SIMMER CONTROL THERMOSTAT & ON-OFF SW	C.P.
B	9-3-76	ADDED VOLTAGES AND NORWAY NOTE ECG CS807	F.B.
C	2-27-91	REVISED TO SHOW PANEL M.T. COMP'S EDM 9309	C.P.

NOTE: FOR NORWAY 230V. 3PH. 50 HZ. 3 WIRE ELECTRICAL SERVICE USE WIRING DIA. B95-3775

DC-BURNING - MARKET FORCE SPECIFICATION#127	CLASS I	CLASS II	CLASS III
USED ON			
B95-3502			
B/M 95-3096			

EVERETT, MA 02149

# WIRING DIAGRAM

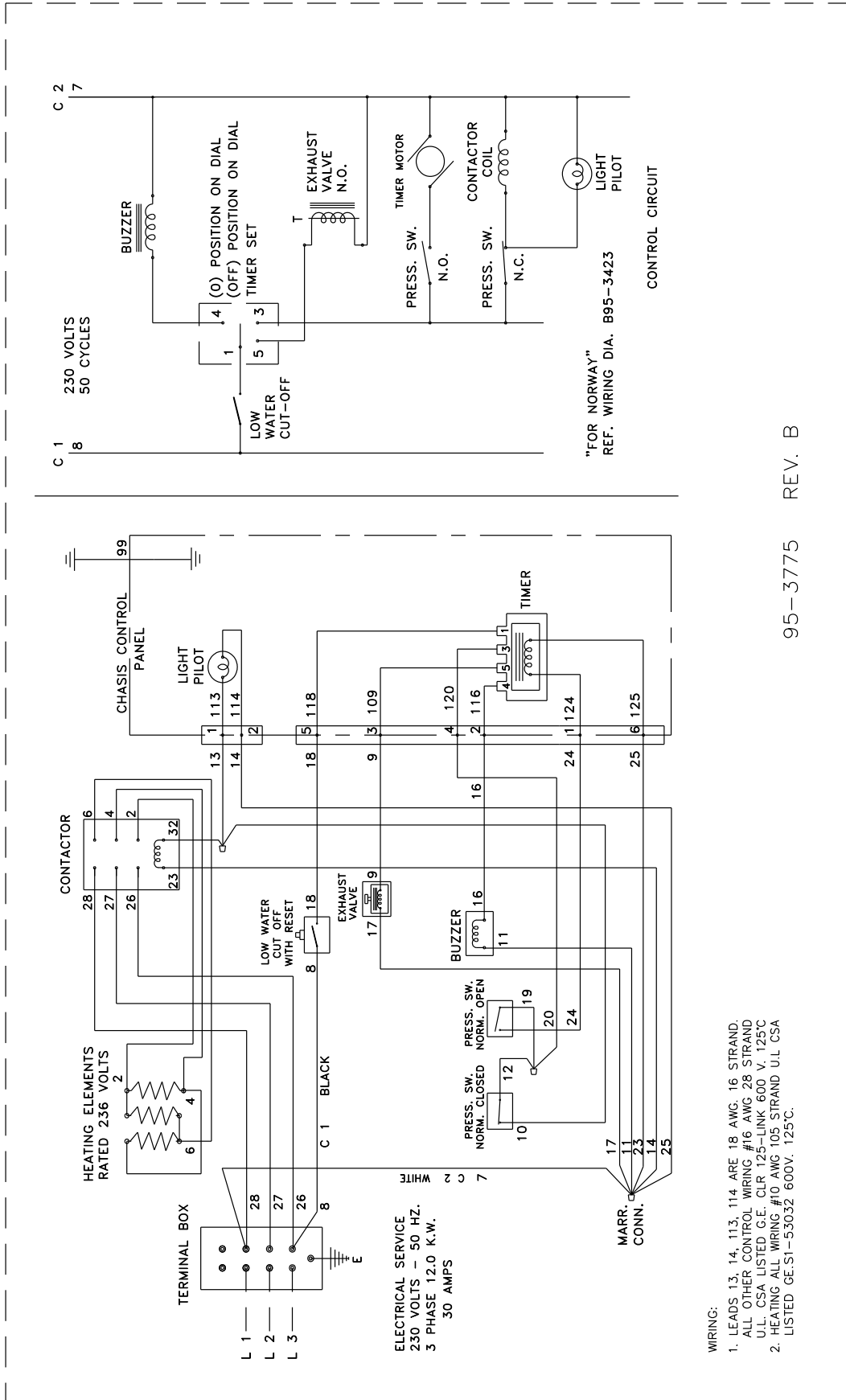

# WIRING DIAGRAM

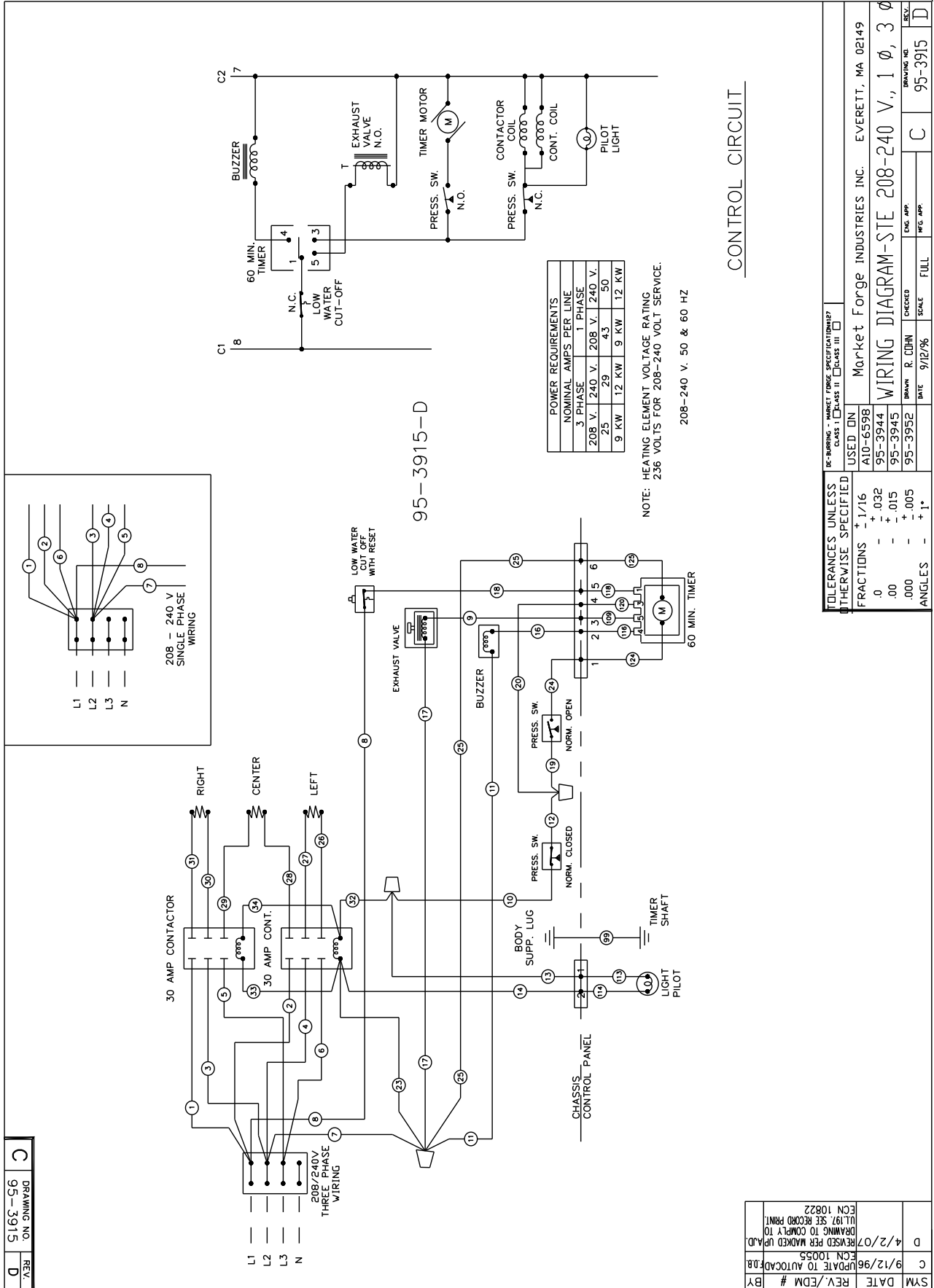

C	DRAWING NO.	95-3915
D	REV.	

BY	REV./EDM #	9/12/96	UPDATE TO AUTOCAD	ECN 10055
C	DATE	4/2/07	REVISED PER MAJOR UP	DRAWING TO COMPLY TO
D	REV.	U1197	SEE RECORD PRINT	ECN 10822

TOLERANCES UNLESS OTHERWISE SPECIFIED		DC-BARRING - MARKET FORCE SPECIFICATIONS? <input type="checkbox"/> CLASS I. <input type="checkbox"/> CLASS III. <input type="checkbox"/>	
FRACTIONS	+ 1/16	USED IN	A10-6598
	- .032		95-3944
	+ .015		95-3945
	- .005		95-3952
ANGLES	+ 1°		
MARKET FORGE INDUSTRIES INC. EVERETT, MA 02149		WIRING DIAGRAM-SIE 208-240 V., 1 Ø, 3 Ø	
DRAWN R. COHN		CHECKED	
DATE 9/12/96		SCALE FULL	
REV. APP.		REV. APP.	
C		95-3915	



# MASTER STEAM-IT ILLUSTRATION

OLD STYLE SHOWN  
NEW STYLE INTERCHANGEABLE

OLD STYLE SHOWN

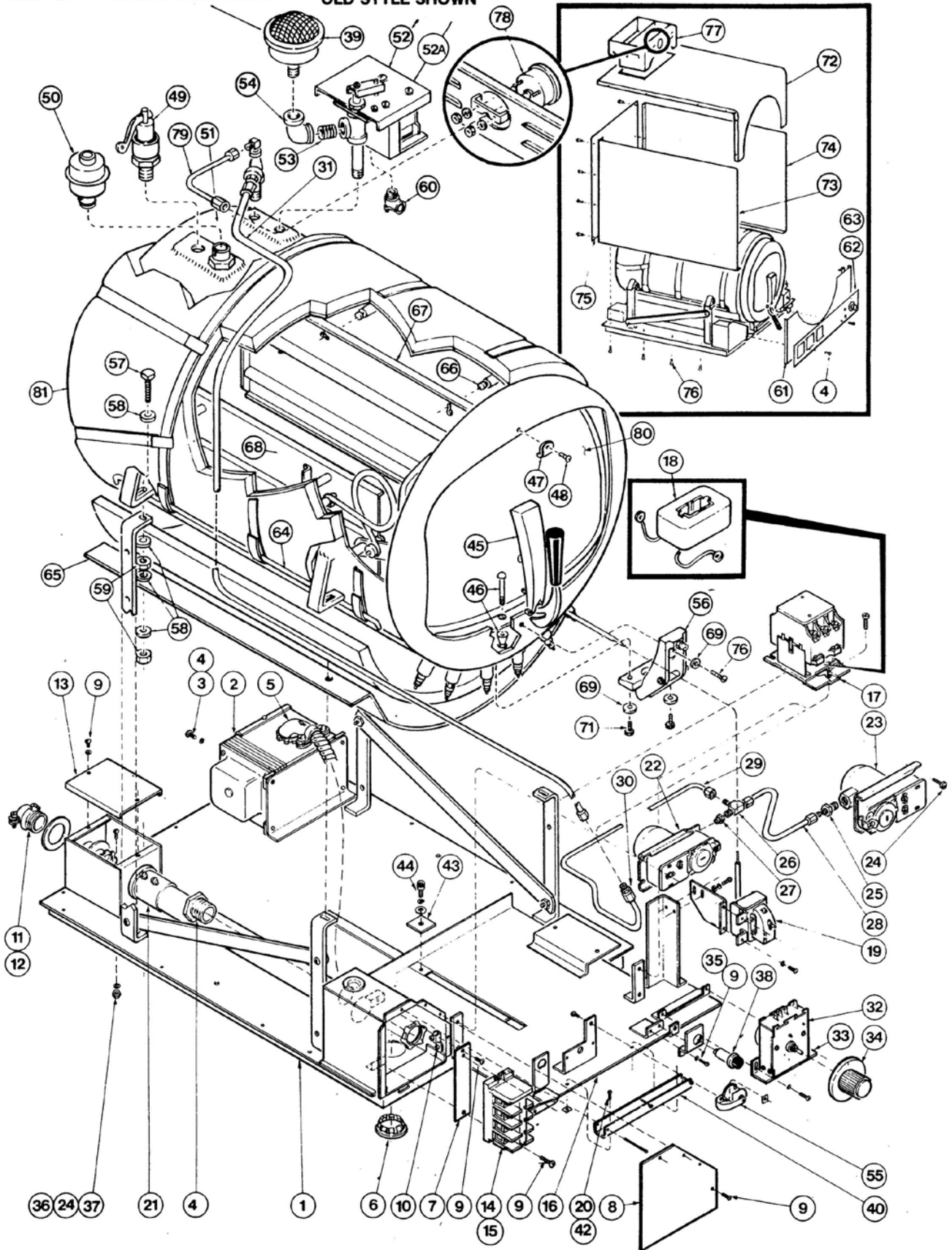

# MASTER STEAM-IT ILLUSTRATION

ITEM	PART NO.	DESCRIPTION
1	95-3301	Baseplate assy. - fixed
2	10-5234	Transformer - 440/480V units
3	*	#10 lockwasher, stainless steel
4	*	#10-32 x 1/2: binding hd. screw, stainless steel
5	95-3394	Lead assy. transformer
6	10-3095	Plug button
7	95-3289	Plate term strip support
8	95-3484	Cover term box
9	*	#8-32 x 1/8" rd. hd. screw, stainless steel
10	10-6969	Ground lug
11	95-3500	Connector
12	10-6967	Reducing washer
13	95-3489	Junction box cover
14	10-6962	Terminal strip section
15	10-6963	Terminal strip end section
16	95-3302	Baseplate sub assy. - moveable
17	10-5466	Contactora 208V, 50/60Hz cycle, complete
-	10-5467	Contactora 230/240V, 50/60Hz cycle, complete
18	10-5470	Coil 208V, 50/60Hz Cycle
-	10-5471	Coil 230V, 50/60Hz Cycle
19	10-5990	Low water cut-off
20	*	#6-32 x 1/4" truss hd. screw, stainless steel
21	10-6966	Connector
22	95-0998	Pressure control - open on rise
23	95-0999	Pressure control - close on rise
24	*	#10-32 x 1/2" rd. screw, stainless steel
25	10-2904	Adapter - straight 1/4 OD - 1/4 IPSM
26	10-3426	Adapter tee - 1/8 IPS - 1/4 OD - 1/4 ODM
27	10-3652	Reducing bushing 1/4-1/8 IPS
28	95-3305	Tube
29	95-3304	Tube - pressure control
30	10-1154	Union compr. fitting 1/4 OD
31	95-3387	Tubing - steam pressure line
32	10-6293	Timer, 60 minute
33	95-3277	Bracket, timer
34	10-6307	Knob, dial
35	95-3403	Bracket, pilot light
36	10-2509	Lockwasher
37	10-2340	Hex nut 10-32
38	10-6669	Pilot light

# MASTER STEAM-IT ILLUSTRATION

ITEM	PART NO.	DESCRIPTION
39	<a href="#">10-4963</a>	Exhaust silencer
40	<a href="#">95-0483</a>	Cage, electric wires
41	<a href="#">10-6964</a>	Conduit nipple
42	<a href="#">10-4110</a>	Speednut #6-32
43	95-0463	Washer
44	*	#10-32 x 3/8 hex socket hd. cap screw, stainless steel
45	<a href="#">95-0144</a>	Door handle assy. complete
46	95-0154	Drain plug assy. complete
47	<a href="#">10-0226</a>	Handle bumper
48	*	#8-32 x 3/8 binding hd. screw ty. "z", stainless steel
49	<a href="#">10-7942</a>	Safety valve
50	<a href="#">10-6156</a>	Steam trap
51	<a href="#">10-6158</a>	Adapter
52	-	Old style exhaust valve
-	95-0944	Exhaust valve 208V, 60 cycle, complete
-	95-0945	Exhaust valve 230-480V, 60 cycle, complete
-	95-0946	Exhaust valve 230V, 50 cycle, complete
-	95-0946	Exhaust valve 208V & 230V, 50 cycle, complete
52A	-	New style exhaust valve ( <i>Not shown</i> )
-	<a href="#">09-6545</a>	Exhaust valve 220/240V, 50/60 cycle, complete
-	<a href="#">09-6536</a>	Exhaust valve 208V, 50/60 cycle, complete
53	<a href="#">10-3852</a>	Nipple 3/8 IPS
54	<a href="#">10-3851</a>	Elow 3/8 IPS st'd. 90°
55	10-6665	Buzzer, complete
56	<a href="#">95-0115</a>	Fulcrum & drain assy.
57	*	5/16-18 x 11/2" sq. hd. screw, st'l. cap pl.
58	*	5/16 flat washer 3/8 ID x #16 ga. st'd. st'l. cap. pl.
59	*	Hex nut 5/16-18, st'l. cap pl.
60	<a href="#">10-5036</a>	Connector 3/8 - 90°
61	<a href="#">95-3388</a>	Front lower panel assy.
62	<a href="#">10-6595</a>	Nameplate panel, 60 cycle
63	<a href="#">10-7096</a>	Nameplate panel, 50 cycle
64	95-1466	Rod
65	<a href="#">95-0465</a>	Pan insulation
66	<a href="#">10-1937</a>	Stud
67	<a href="#">95-2545</a>	Pan rack assy. right side
68	95-2546	Pan rack assy. left side
69	*	1/4 shake-proof int. tooth lockwasher, stainless steel

\* These parts are available at local hardware, plumbing and electrical outlets. If not obtained, special prices will be quotes by Market Forge on request.

# FULCRUM & DRAIN ASSEMBLY

USED FROM 4/75-10/85

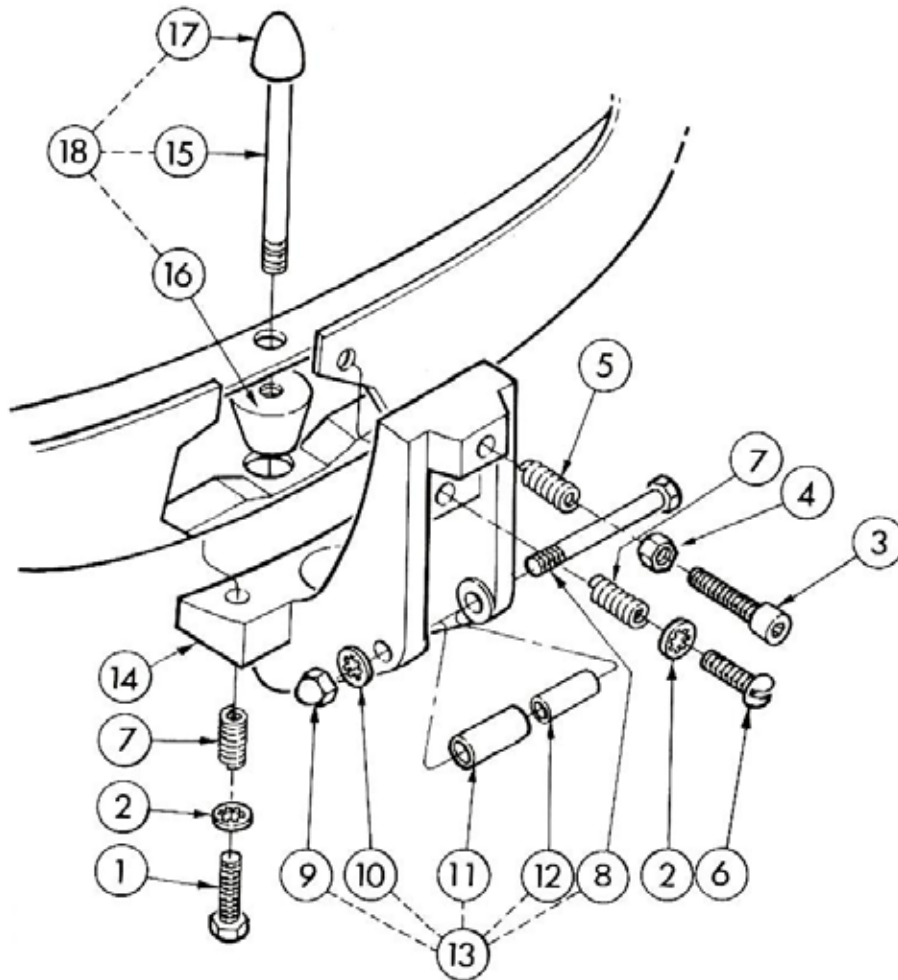

ITEM	PART NO.	DESCRIPTION
1	95-0116	Fulcrum & drain casting
2	10-3111	1/4-20 x 3/8 helicoil
3	10-2513	1/4" shake-proof washer
4*	10-1790	1/4-20 cap screw, 7/8" long
5	10-2318	10-32 acorn nut
6	10-2514	#10 shake-proof lockwasher
7	95-0198	Bronze bearing
8	95-0120	Bearing spacer
9	10-1999	10-32 machine screw 1.5" long
10	95-0149	Roller assy. (#5 thru 9)

ITEM	PART NO.	DESCRIPTION
11*	10-1763	1/4-20 machine screw, 3/4" long
12	10-2087	1/4-20 allen set screw
13	10-2353	1/4-20 jam nut
14	10-3116	1/4-20 x 5/8 helicoil
--	95-0115	Complete fulcrum assy. (#1 thru 14)
15	95-0658	Drain plug handle
16	10-2227	Drain plug
17	10-2359	1/4-20 acorn nut
18	95-2604	Drain & plug handle assy. (complete)

\* Obtain at local hardware store.

# FULCRUM & DRAIN ASSEMBLY

FOR UNITS BUILT AFTER 10/85

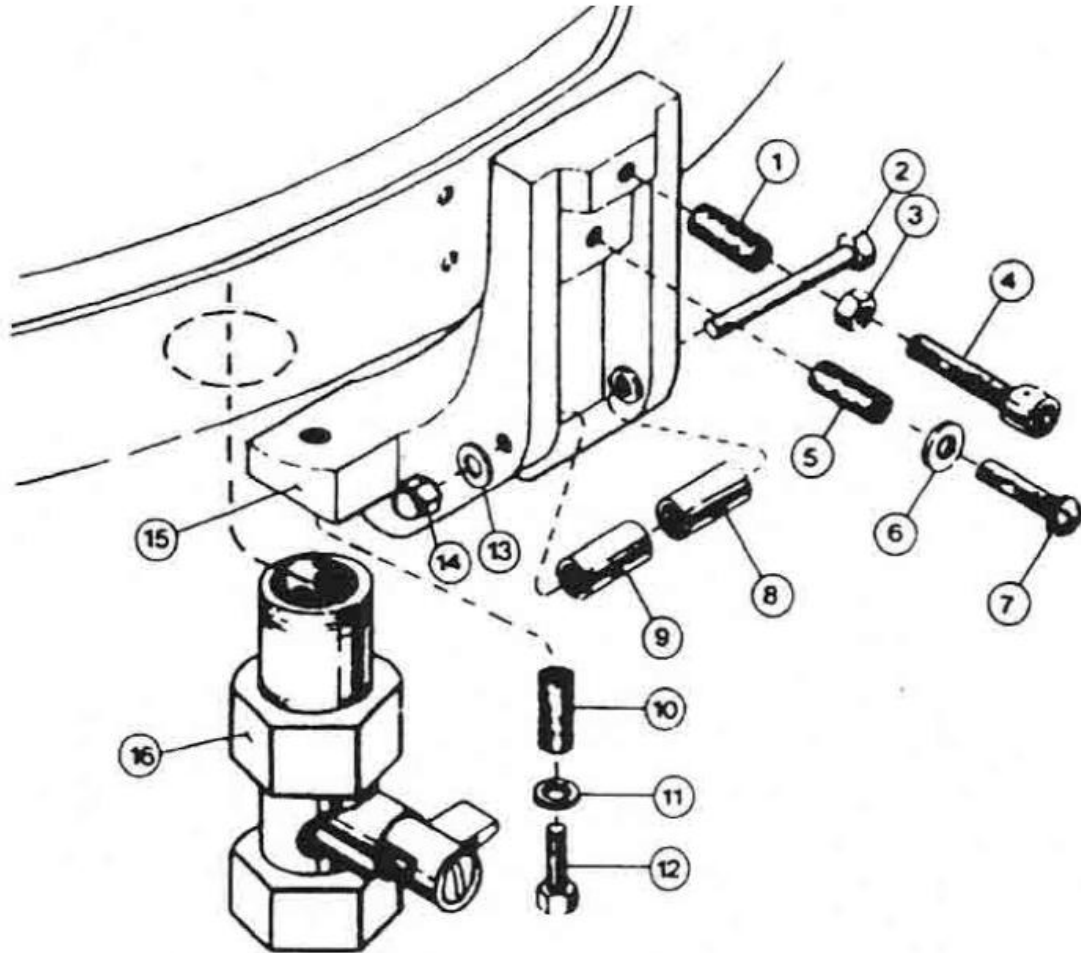

ITEM	PART NO.	DESCRIPTION
1	10-3116	1/4-20 x 5/8 helicoil
2	10-1999	10-32 machine screw, 1 5/8" long
3	10-2358	1/4-20 fulcrum nut
4	10-0287	1/4-20 allen set screw
5	10-3111	1/4-20 x 3/8 helicoil
6	10-2513	1/4" shake-proof washer
7*	10-1763	1/4-20 machine screw, 3/4" long
8	95-0120	Bearing spacer
9	95-0198	Bronze bearing

ITEM	PART NO.	DESCRIPTION
10	10-3111	1/4-20 x 3/8 helicoil
11	10-2513	1/4" shake-proof washer
12*	10-1790	1/4-20 cap screw, 7/8" long
13	10-2514	#10 shake-proof lockwasher
14	10-2318	10-32 acorn nut
15	95-3850	Fulcrum & drain casting
16	10-1041	Ball valve
--	95-3992	Fulcrum & drain assy. (#1 thru 15)

\* Obtain at local hardware store.

# EXHAUST VALVE

BUILT PRIOR TO JULY 1983

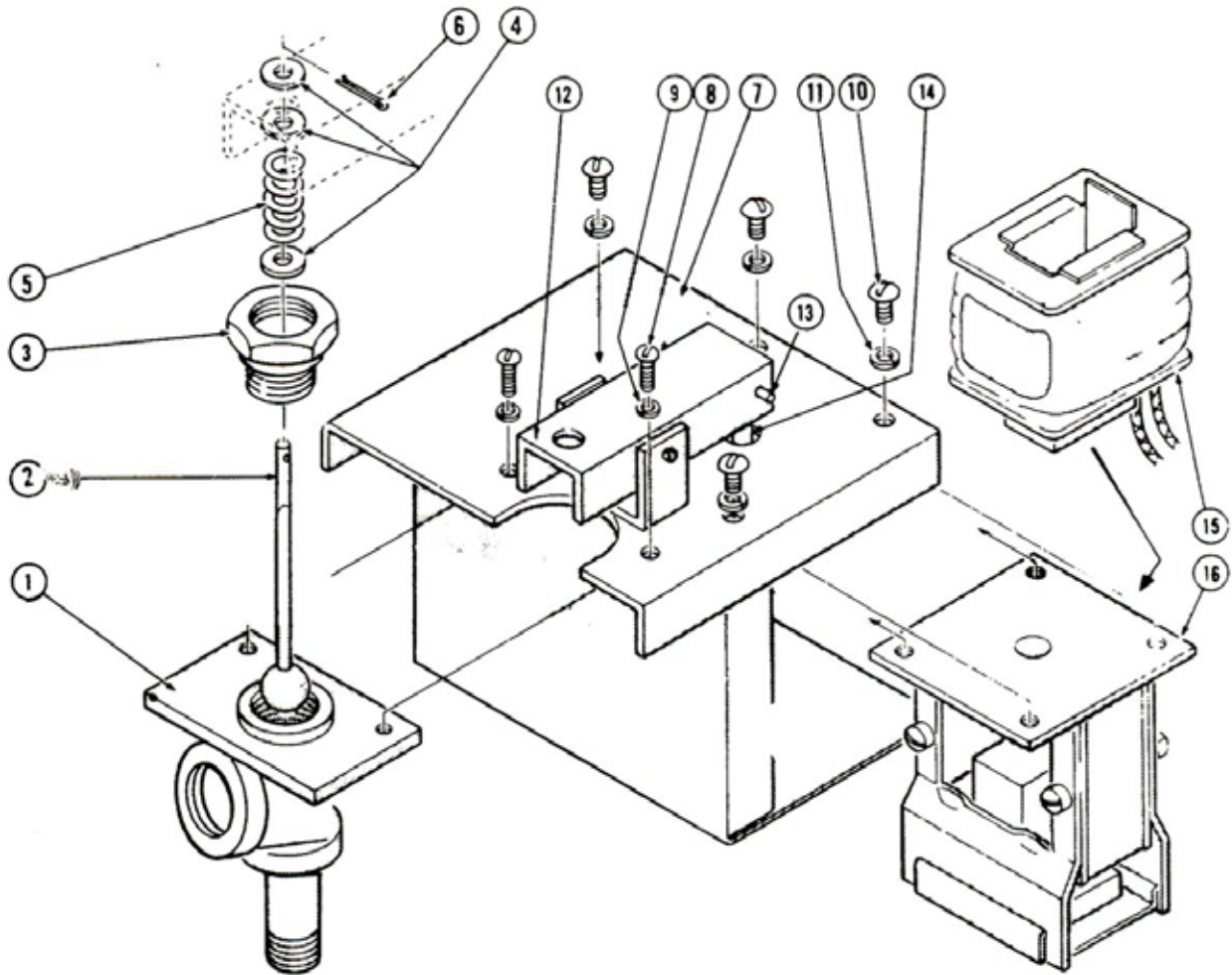

ITEM	PART NO.	DESCRIPTION
1	95-0756	Tee assy.
2	95-0372	Ball & pin assy.
3	95-2077	Diaphragm body assy.
4	10-2425	#10 flat washer 3/16" ID x 1/2 OD x .086 (cad. pl)
5	10-4675	Spring compression
6	10-1663	Pin, cotter 1/16 x 1/2" stainless steel
7	95-0431	Solenoid bracket assy.
8	10-1759	#10 10-32 x 3/8" rd. hd. screw (cad. pl)
9	10-2505	#10 lockwasher (cad. pl)
10	10-1701	1/4-20 x 3/8" rd. hd. screw (cad. pl)
11	10-2500	1/4 lockwasher (cad. pl)
12	95-0755	Channel
13	10-1678	Pin, roll 1/8 x 1-1/8" (cad. pl)
14	95-0760	Pin, solenoid

ITEM	PART NO.	DESCRIPTION
15	10-6663	Coil - 208V, 60 cycle
	10-6664	Coil - 208V, 50 cycle
	10-6656	Coil - 230V, 60 cycle
	10-6657	Coil - 230V, 50 cycle
16	10-6662	Solenoid - 208V, 60 cycle, complete
	10-6667	Solenoid - 208V, 50 cycle, complete
	10-6655	Solenoid - 230V, 60 cycle, complete
	10-6660	Solenoid - 230V, 50 cycle, complete
-	95-0944	Exhaust valve, 208V, 60 cyle, complete
	95-0947	Exhaust valve, 208V, 50 cyle, complete
	95-0945	Exhaust valve, 208-480V, 60 cyle, complete
	95-0946	Exhaust valve, 230V, 50 cyle, complete
-	95-3197	Assy. (#1 thru 6) complete

# EXHAUST VALVE

BUILT AFTER JULY 1983

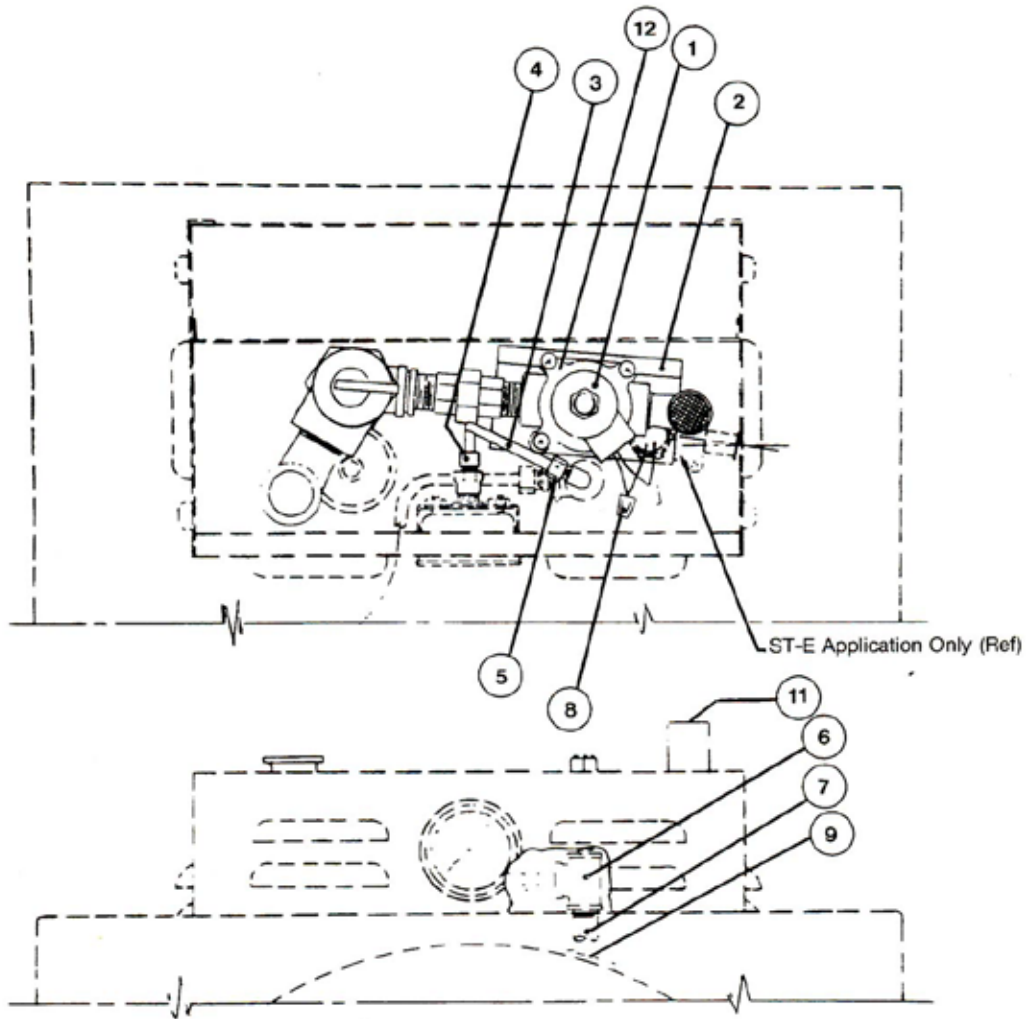

ITEM	PART NO.	DESCRIPTION	QTY
1	C95-3996	Assy. piping exhaust, 208-240V, 50/60Hz	1
2	C95-3990	Heat deflector plate	1
3	A95-3270	Tubing, pressure gauge	1
4	10-3361	Pem. comm. brass 1/8 IPS x 3/16 OD	1
5	10-3360	90° comp. 1/8 IPS male 3/16 OD	1
6	10-3432	Tee reducing - brass ( <i>existing</i> )	REF.
7	10-3420	Nipple - brass chr. pl. ( <i>existing</i> )	REF.
8	10-5143	Marr connector	2
9	P09-4838	Plug, countersink 1/4 IPS br. chr. pl.	1
10	10-1643	Packing, corrugated carton - 8 x 8 x 6	1
11	A10-4963	Silencer, exh., steam-it	1
12	09-6545	Exhaust valve only 220-240V, 50/60Hz	-
-	09-6536	Exhaust valve only 208V, 50/60Hz	-

# DOOR HANDLE ASSEMBLY

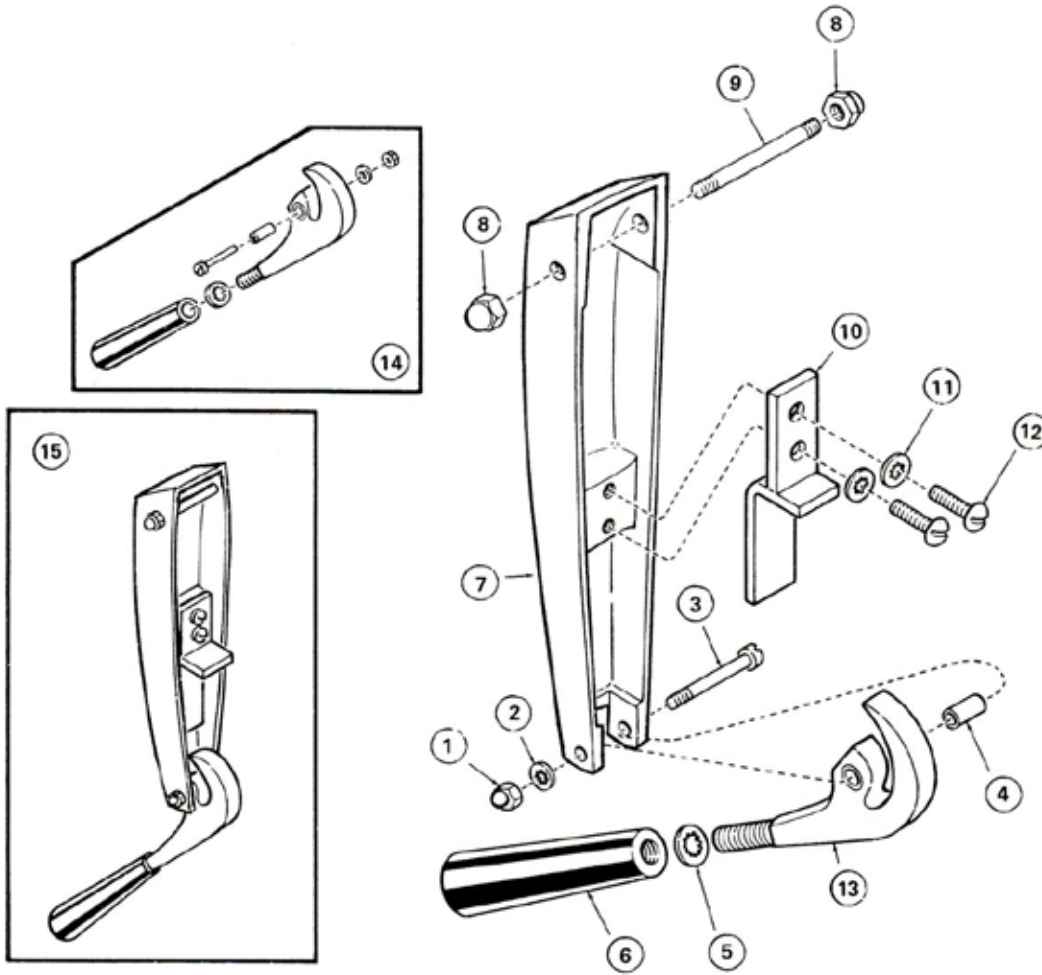

ITEM	PART NO.	DESCRIPTION
1	10-2318	#10-32 acorn nut
2	10-2514	#10 shake-proof lockwasher
3	10-1999	Locking screw
4	95-0120	Bearing spacer
5	10-2517	3/8" shake-proof lockwasher
6	10-0050	Door lock knob
7	95-0134	Door handle casting
8	10-2359	1/4"-20 acorn nut
9	95-0658	Door handle bearing stud
10	14-0721	Door handle bearing bracket
11	10-2513	1/4" shake-proof lockwasher
12*	10-1731	1/4"-20 x 5/8" rd. hd. screw
13	95-3223	Door lock assy.
14	95-0145	Door lock knob assy. (#1 thru 6 & 13)
15	95-0144	Complete door handle assy. (#1 thru 13)

\* Obtain at local hardware store.

# DOOR ASSEMBLY

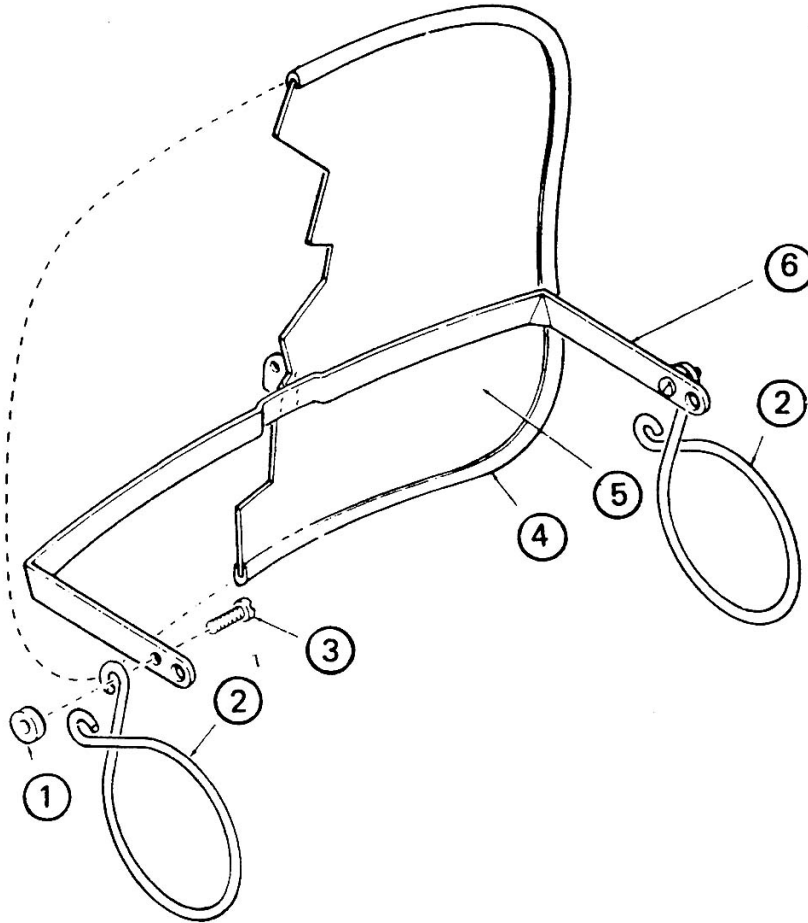

ITEM	PART NO.	DESCRIPTION
1	10-6765	Pivot spring bearing
2	10-2785	Door lift springs ( <i>pair</i> )
3	10-1776	10-32 machine screw 1/2" long
4	10-2666	Door gasket
5	95-3204	Door & door spring assy.
6	95-0127	Door spring
--	95-0124	Complete door assy. (1 thru 6)

## STAND ASSEMBLY - OPTIONAL STEAM-IT STAND

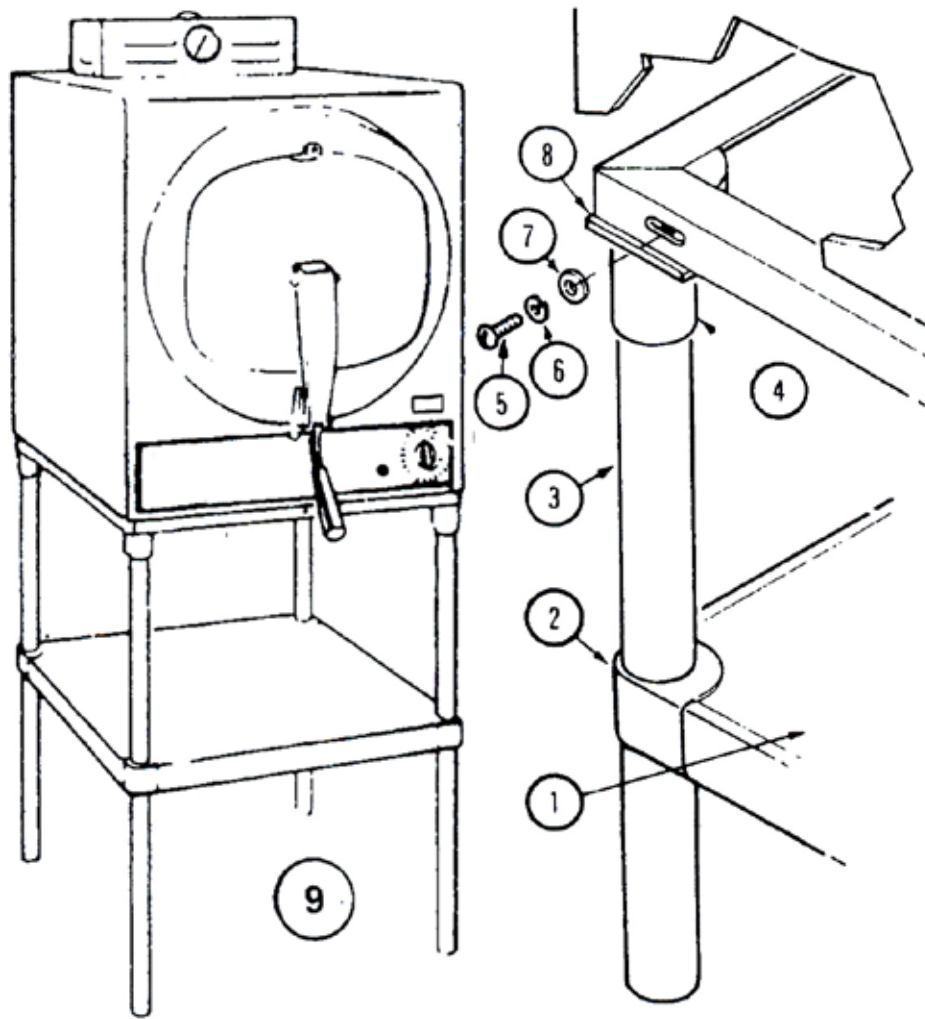

ITEM	PART NO.	DESCRIPTION
1	<a href="#">95-1680</a>	Shelf
2	<a href="#">25-1507</a>	Corner bracket with set screw
3	<a href="#">10-0634</a>	27" leg
4	<a href="#">10-0635</a>	Leg top
5	<a href="#">10-1804</a>	Rd. Hd. Screw 1/4"-20 x 5/8"
6	<a href="#">10-2520</a>	Lockwasher 1/4"
7	<a href="#">10-2400</a>	Flat washer 1/16" thick
8	95-3211	Cap bracket
9	95-0300	Complete stand assy.

# CABINET ASSEMBLY

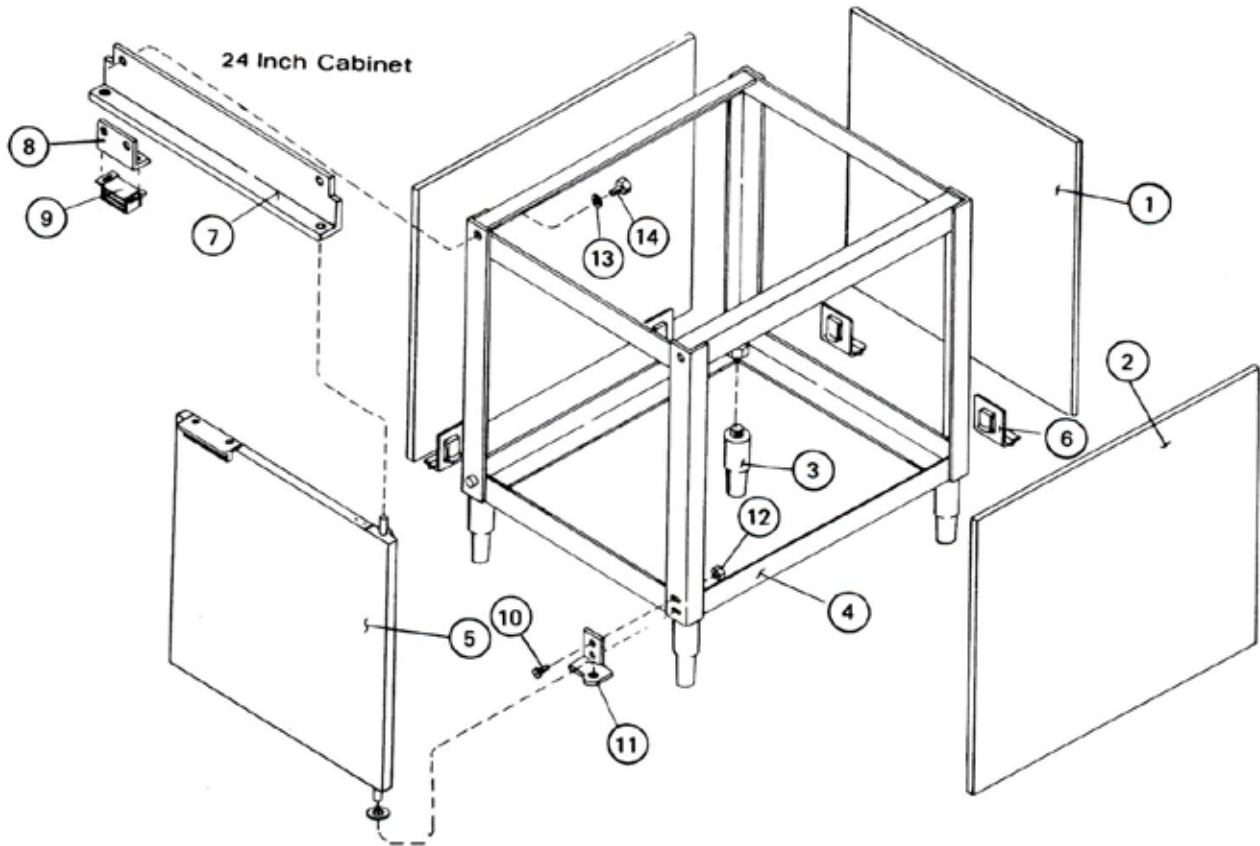

ITEM	PART NO.	DESCRIPTION
1	<a href="#">90-2657</a>	Rear panel stainless steel
Kit	90-3013	Rear panel stainless steel kit
2	<a href="#">90-2661</a>	Side panels, right & left stainless steel
Kit	<a href="#">90-9039</a>	Side panels, right & left stainless steel kit
3	<a href="#">10-0631</a>	Leg
4	90-8974	Assembly 24" x 33" modular frame
5	90-2993	Door assembly left hand stainless steel
Kit	90-9098	Door assembly left hand stainless steel kit
-	<a href="#">90-3154</a>	Door assembly right hand stainless steel
6	90-2663	Panel MTG bracket

ITEM	PART NO.	DESCRIPTION
7	10-0493	Feature strip
8	<a href="#">90-3210</a>	Bracket magnetic catch
9	<a href="#">10-5561</a>	Magnetic catch
10	<a href="#">10-1869</a>	No. 10-32 x 1/2" flat head screw
11	10-0454	Cabinet hinge right bottom
	10-0453	Cabinet hinge left bottom
12	10-2365	Lock nut
13	<a href="#">10-2511</a>	Washer
14	<a href="#">10-2307</a>	Hex nut

\* Obtain at local hardware store