

OWNER'S MANUAL

MARINE STEAM-IT ELECTRIC COUNTER MODEL

MODEL: • SB-ST-E



DISTRIBUTION STATEMENT

THIS PUBLICATION IS REQUIRED FOR OFFICIAL USE FOR ADMINISTRATIVE OR OPERATING PURPOSES. DISTRIBUTION IS LIMITED TO U.S. GOVERNMENT AGENTS ONLY. OTHER REQUEST FOR THIS DOCUMENT MUST BE REFERRED TO COMMANDER, NAVAL SEA SYSTEMS COMMAND, SEA 09, WASHINGTON, DC 20362.

WARNINGS:

BE SURE TO GROUND THE COOKER CHASES FROM THE GROUND TERMINAL BOX TO THE OUTSIDE GROUND. REFER TO WIRING DIAGRAM C95-3914.

DO NOT OPEN THE DRAIN VALVE WHILE THE STEAM COOKER IS OPERATING. PREMATURE OPENING MAY RESULT IN SCALDING OF THE OPERATOR.

DO NOT LEAVE HAND ON HANDLE.

TO PREVENT SCALDING, THE OPERATOR SHOULD KEEP HANDS OFF THE DOOR HANDLE WHILE EXCESS STEAM/VAPOR IS ESCAPING.

THE ELECTRIC POWER SUPPLY MUST BE DISCONNECTED PRIOR TO PERFORMING ANY MAINTENANCE/REPAIR WORK.

CAUTION:

HELP PREVENT PITTING OF THE ALUMINUM INTERIOR. DO NOT USE STRONG DETERGENT OR ABRASIVE CLEANERS.

NOTES:

TO ASSURE A PROPER PRESSURE SEAL, THE DOOR GASKET MUST BE FREE OF SOIL, SCALE AND BREAKS.

SHOULD THE COOKING CYCLE BE STARTED WITH INSUFFICIENT WATER IN THE COMPARTMENT, THE SAFETY ACTION OF THE LOW WATER CUT-OFF WILL SHUT THE UNIT DOWN. WHEN ADEQUATE WATER (TOTAL: 6 QUARTS) IS ADDED TO THE CHAMBER, THE COOKING CYCLE MAY BEGIN AGAIN.



MARKET FORGE



FEDERAL SPEC S-C-1474B / S6161-PA-FSE-010-/38379
TYPE SC1474-3106MA1 / 0910-LP-436-6200

Telephone: (802) 658-6600 Fax: (802)864-0183
www.marketforge.com

PN 14-0299 Rev C (11/17)

S6161-PA-FSE-010-/38379

0910-LP-436-6200

DISTRIBUTION STATEMENT:

THIS PUBLICATION IS REQUIRED FOR OFFICIAL USE FOR ADMINISTRATIVE OR OPERATIONAL PURPOSES. DISTRIBUTION IS LIMITED TO U.S. GOVERNMENT AGENTS ONLY. OTHER REQUEST FOR THIS DOCUMENT MUST BE REFERRED TO COMMANDER, NAVAL SEA SYSTEMS COMMAND, SEA 09, WASHINGTON, DC 20362.

TABLE OF CONTENTS

INSTALLATION

SERVICE CONNECTIONS.....	1
ELECTRICALLY OPERATED	1
CERTIFICATIONS	1
UNPACKING & ASSEMBLY	1
ELECTRICAL CONNECTIONS	2
TERMINAL BOX LOCATION (FIG. 1)	2
INSTALLATION CHECK-OUT	2
INITIAL CONTROL SETTINGS	2
COOKER CHECK-OUT	2
SHUTDOWN PROCEDURE	2

PRINCIPLES OF OPERATION

GENERAL	3
OPERATION SEQUENCE	3
PRELIMINARY PROCEDURES	3
WIRING DIAGRAM (FIG. 2)	4
HOSE ASSEMBLY (FIG. 3)	5
PREHEATING	6
FACTS ON PARADE	6
RECOMMENDED COOKING TIMES	7
THE FLUE	10
TO REMOVE THE FLUE	10
STEAM GAUGE	10
STEAM TRAP	10
HOW IT WORKS	10
TROUBLE TEST AND REMEDIES	10
FLUE REMOVAL ITEMS (FIG. A)	10

MAINTENANCE

PREVENTIVE MAINTENANCE	11
DOOR ASSEMBLY	11
GASKET REPLACEMENT	11
DOOR SEAL TENSION ADJUSTMENT	12
DOOR LIFT SPRING REPLACEMENT	12
STEAM EXHAUST VALVE & TRAP REPLACEMENT	12
DAILY CLEANING	12
WEEKLY CLEANING	12
CLEANING EXHAUST SILENCER	13
CLEANING TROUBLE-SHOOTING GUIDE (STAINLESS STEEL)	13

ILLUSTRATED PARTS LIST

COOKER COMPARTMENT (FIG. 7)	14
DOOR HANDLE ASSEMBLY (FIG. 8)	17
THE COOKER DOOR ASSEMBLY	18
DOOR ASSEMBLY (FIG. 9)	18
FULCRUM & DRAIN ASSEMBLY	18
ROLLER ASSEMBLY	18
OLD STYLE FULCRUM & DRAIN ASSEMBLY (FIG. 10)	19
NEW STYLE FULCRUM & DRAIN ASSEMBLY (FIG. 11)	19
SAFETY VALVE	19
CHECKING SAFETY VALVE	19
EXHAUST VALVE (FIG. 12)	20
NEW EXHAUST VALVE, BUILT AFTER JULY 1983 (FIG. 13).....	21

TROUBLE-SHOOTING

OLD STYLE BUILT PRIOR TO SEPTEMBER 1980 (FIG. 14)	22
ELEMENT CONTROL SWITCH	22
HOW IT WORKS	22
DIAL ADJUSTMENT	22
NEW STYLE BUILT AFTER SEPTEMBER 1980 (FIG. 15)	22
RECALIBRATING ELEMENT CONTROL SWITCH	22
PRESSURE CONTROL SWITCH (BARKSDALE)	22
OPERATING PRESSURE ADJUSTMENT (BRAKSDALE)	22
RECALIBRATING PRESSURE CONTROL SWITCH	23
LOW WATER CUT-OFF	23
HOW IT WORKS	23
TIMER	23
TROUBLE TEST & REMEDIES	23
TIMER CONTROL SWITCH.....	23
HOW IT WORKS	23
DIAL ADJUSTMENT	23
RECALIBRATING TIMER CONTROL SWITCH.....	23
PILOT LIGHT	23
TROUBLE-SHOOTING GUIDE	24

INSTALLATION

SERVICE CONNECTIONS

EC	Electrical Connection - Connection for incoming power supply wires on terminal block
EP	Power Supply - 1-1/4" threaded access hole for power supply wires. Use wire suitable for at least 90°C. Nominal amps per line.
D	Drain - 1/2" 13mm O.D. tubing. Air break required for drain connection supplied by others
CW	Cold Water - 3/8" 10mm O.D. tubing connection to fill hose. Cold water line shall have a max of 50 PSI 3.5kg/cm ² and a min of 25 PSI 1.7kg/cm ² water pressure
CG	Center of Gravity - with flanged feet

WATER SUPPLY

Good quality water feed is the responsibility of the owner. Water quality must be within the following general guidelines.

TDS: 40-125 ppm Hardness: 35-100 ppm Chlorine: <0.2 ppm
 Silica: <13 ppm Chlorides: <25 ppm
 Chloramine: <0.2 ppm pH: 7.0 - 8.5

The best defense against poor water quality is a water treatment system designed to meet your water quality conditions.

Appliance to be installed with backflow protection according to federal, state or local codes.

DIMENSIONS ARE IN INCHES [MM]

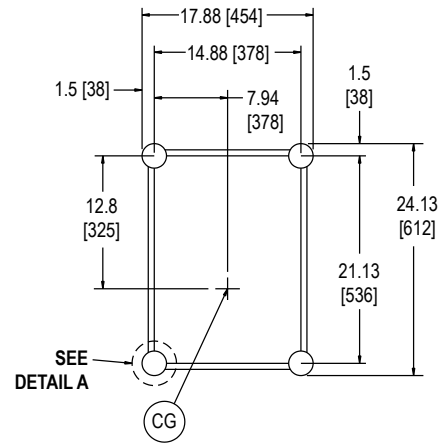
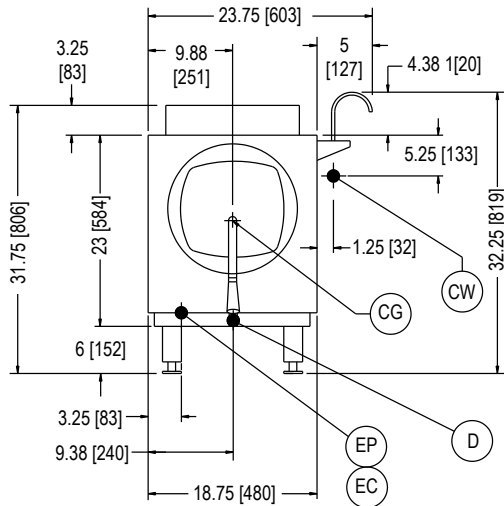

BOTTOM VIEW

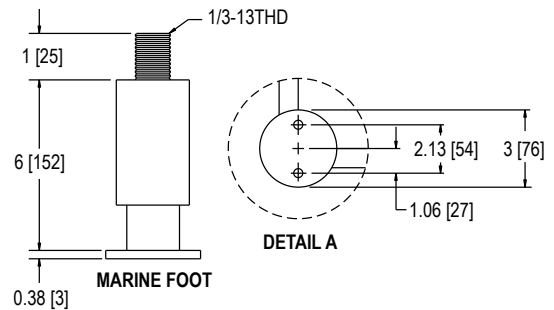

MARINE FOOT

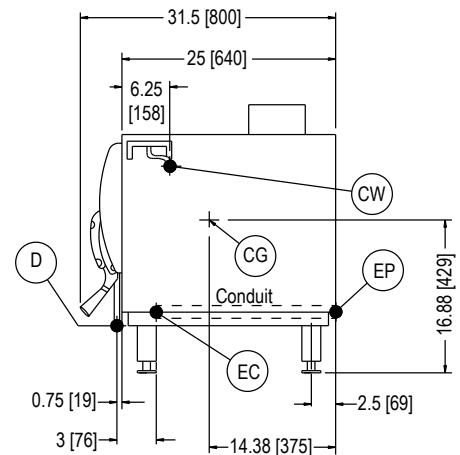

UNPACKING AND ASSEMBLY:

The Steam-It cooker is shipped in a carton with protective padding and mounted on a wooden pallet. Carefully remove the carton, padding and the bolts securing the unit to the wooden pallet. Inspect assemblies as follows:

1. Inspect unit overall for dents or deformations in stainless steel cabinet enclosures.
2. Make sure visible attaching hardware for all assemblies are not missing or damaged.
3. Inspect timer, indicator light, RESET switch and pressure gauge to see they are not damaged.
4. Install pan supports so that the horizontal keyhole is at the rear of the cooking chamber and so that the flange and embossments face the middle of the chamber.

5. Install the set (4 each) of Marine flanged feet (3" diameter flanged plates) so the steam cooker can be mounted on a counter top (refer to spec sheet S-2160) for flanged feet details.
6. Install the part number 95-3849 rinse and fill hose unit on the shipboard steam cooker. Refer to the enclosed drawing C95-3897 Rev A for installation details.

NOTE: The cooker is carefully inspected and packaged before leaving the factory. If there are missing components or unit is damaged, notify the carrier immediately.

Should repairs be required, a network of authorized service agencies is available to assist with prompt service. If necessary, please contact:

INSTALLATION

Product Service Department Market Forge
Toll Free: (866) 698-3188
Parts, Service and Availability Toll Free No.:
(888) 259-7076
custserv@marketforge.com, www.marketforge.com

The Model and serial numbers must be referenced when corresponding with Market Forge. The data plate containing the serial number pertaining to the equipment is located on the front top of the cabinet.

ELECTRICAL CONNECTION:

The electrical connection may be made at the terminal box located at the lower left side of the Steam-It removing the small covering panel (see figure 1 below, and service connections on previous page).

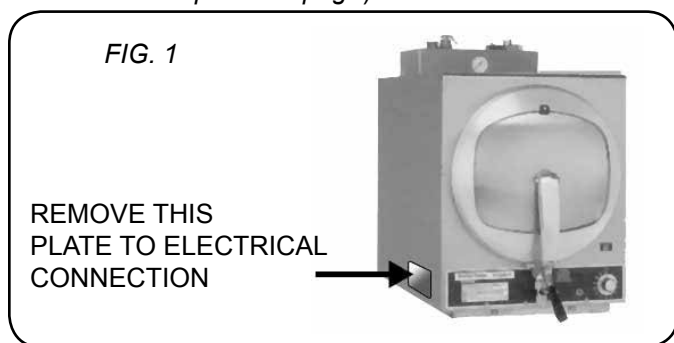

Power input is 12 kW at 208, 236 or 440 Volt, 60 cycle A.C. Equipment is adaptable for single or three phase. Unit must be grounded. Wires should be brought up through conduit at bottom of cooker (see wiring diagram [c95-3914 Rev A \(440V/6pH/60Hz\)](#) for instructions on making connection. Unit must be fused separately.

NOTE: Refer to the spec sheet, side 2 on page 2 for the complete list and location of the required service connection and electrical details.

WARNING: BE SURE TO GROUND THE COOKER CHASES FROM GROUND TERMINAL BOX TO AN OUTSIDE GROUND. REFER TO WIRING DIAGRAM [C95-3914 REV A](#) ENCLOSED. ALL RECOMMENDED SAFETY PRECAUTIONS SHOULD BE OBSERVED WHEN CONNECTION THIS UNIT TO THE EXISTING POWER SUPPLY.

INSTALLATION CHECK-OUT:

After the Steam-It cooker is completely assembled and properly located with electrical supply connected, the cooker must be given a thorough checkout before being put into cooking operation.

Before making this checkout the operator must be thoroughly familiar with the operating procedures in Section 3 and with the function of each control described in principles of operation in Section 3. Reference Figure 4 for identification of controls required in the following procedures. If the unit fails to perform as described below, con-

sult the trouble shooting guide for corrective action.

INITIAL CONTROL SETTINGS:

Before beginning cooker checkout procedures, perform the following steps:

1. Check to see that the timer is off.
2. Visually check interior of cooking compartment and remove any materials, papers, etc. Check to see that pan supports are properly installed (refer to principles of operation in Section 3, step 5) and secured.
3. Check pressure gauge to see that it registers zero pounds.

COOKER CHECK-OUT:

The cooker checkout procedures are as follows:

1. Secure the drain valve (refer to operating instructions S-202B figure No. 4 on page 7) then pour six (6) quarts of water into the steam-it cooking compartment through the door opening.

WARNING: BE CERTAIN THE DRAIN VALVE IS CLOSED AND DO NOT OPEN IT WHILE THE UNIT IS OPERATING, PREMATURE OPENING MAY RESULT IN SCALDING OF THE OPERATOR.

2. Close the door and lock in position by placing the tongue of the door lock under the roller on the drain casting and pressing downward until door lock comes to a firm stop. This lock makes the initial seal. (When steam pressure builds up in the compartment it will force the door to a tighter closed position.)
3. Turn the Steam-It on by setting the timer to the desired cooking time. Observe pressure increase indicated by pressure gauge.
4. At the close of the preset cooking period, the timer pointer will stop at the "0" position on the dial. This will shut down the Steam-It and automatically open the exhaust valve. The Buzzer will continue to sound until the dial pointer is manually turned to the "OFF" position.
5. Observe that the indicator light goes out when timer is at the "0-minute" position. Check the pressure gauge to see that the pressure reads zero. The door will not open while there is steam pressure working against it from within the cooking compartment. The door must be kept locked until the cooking cycle has completely finished, then the door opened to allow vapor to clear. Shut off gas supply by closing the gas shutoff valve.

SHUTDOWN PROCEDURE:

No special shutdown procedures are required with the exception that the door is left open, timer must be in the OFF position and the gas supply valve closed, (consult local codes for daily shut-off requirement).

NOTE: Before using the Steam-It for cooking, it is recommended that checkout operations be performed 2 or 3 times in order to determine that it is working properly and to insure cleanliness of the cooking compartment.

PRINCIPLES OF OPERATION

PLEASE READ CAREFULLY THE FOLLOWING INFORMATION AND THE OPERATING INSTRUCTIONS ON THE FOLLOWING PAGES.

CAUTION: The model SB-ST-E Steam-It pressure cooker cylinder is constructed of a corrosion resistant al-clad aluminum alloy. The protective properties of this material afforded to the interior portion of, the cylinder which is exposed to water may be destroyed by allowing a film to form. Such a film can be caused by salt, or other contaminants in the water. If the water supply is known to be hard or corrosive, a source of treated water should be used. Corrosion may also occur if water is not drained daily. Do not use distilled water.

NOTE: Market Forge will not be responsible for damage resulting from the use of hard or corrosive water, from failure to drain the unit daily, or from inadequate cleaning procedures.

GENERAL:

The model SB-ST-E Marine Electric Steam-It pressure cooker (15 PSI operation) consists of one (1) cooking compartment into which pans of food product are loaded through an inwardly opening door. The self-contained cooker is fitted with electric heating elements for 440V/3PH/60HZ operation (16 amps) rated at 12KW impute

OPERATION SEQUENCE:

With water placed in the Steam-It to the recommended six quart level and the door firmly locked to make a tight seal, a cooking cycle will automatically be performed with the act of setting the timer to the length of cooking time desired. The automatic sequence of operation is:

STEP 1 Upon setting the timer, a current flows to: The exhaust valve solenoid, activating it to close the exhaust valve: The element pressure control switch, which relays a current flow to the contactor coil causing the contactor to close and direct electricity to the heating elements: The cooking cycle light, which remains in circuit while the heating elements are on.

STEP 2 As steam is produced within the cooking cylinder, trapped air escapes through the steam trap. The steam trap is induced to close thermostatically when live steam fully replaces the trapped air passing through it. Free-venting will automatically cease and cooking cylinder will become steam-tight. A build-up of cooking cylinder steam pressure will occur.

STEP 3 When the steam pressure build-up reaches 10 PSI, the timer control switch will activate the timer to start its timing cycle.

STEP 4 When the steam pressure build-up reaches 14 PSI, the element control switch will cut off the current flow to the contactor, causing it to open and cut off electricity to the heating elements. When cooling causes the pressure to drop to 13 PSI, the element control switch will again activate the contactor to close and restore the flow of electricity to the heating elements. Thus, by controlling the contactor to open and close intermittently, the element control switch, in effect, maintains the cooking cylinder steam pressures between 13 and 14 PSI.

STEP 5 (Timer reaches "Zero" position) When the timer reaches "Zero" (the end of the cooking cycle), a circuit is completed to the buzzer allowing it to sound while the circuit to the pilot light is broken. The steam exhaust valve will open and the cooking chamber is automatically exhausted of steam. The buzzer will continue to sound until the timer knob is turned to the "Off" position. The door will not open while there is steam pressure working against it from within the cooking cylinder. The door must be kept locked until the cooking cycle has completely finished, then open the door, allow a second or two for the vapor to clear and remove the foods.

PRELIMINARY PROCEDURES:

1. Ensure that electric supply is connected and operating at until See Installation Instructions.
2. Close drain valve (fig. 4, No. 3) by turning valve handle Clockwise.
3. Hang pan supports (fig. 4, No. 2) on pan support studs (cylinder side walls). The horizontal keyhole on the support should be at rear or compartment and vertical keyhole near front.
4. Pour approximately six quarts of water directly into Steam-It cylinder.

NOTE: In geographical locations where a high amount of lime and alkaline (salt-lime substance) deposits are present in water Supply, add two tablespoons of vinegar directly into six quarts of water in Steam-It compartment prior to starting cooking cycle. If more water is added to maintain required level, an occasional table Spoon of vinegar may be added as well, in order to compensate for new mineral deposits fresh water.

CAUTION: A high degree of mineral salts in water can cause pitting of cooking compartment unless above directions (See NOTE) are followed; the cooking compartment thoroughly cleaned and drained each night; and the door left open. Also, do not scour cylinder With abrasive cleanser.

WARNING: DO NOT OPEN DRAIN VALVE WHILE UNIT IS OPERATING. PREMATURE OPENING MAY RESULT IN SCALDING OF OPERATOR.

PRINCIPLES OF OPERATION

FIG. 2

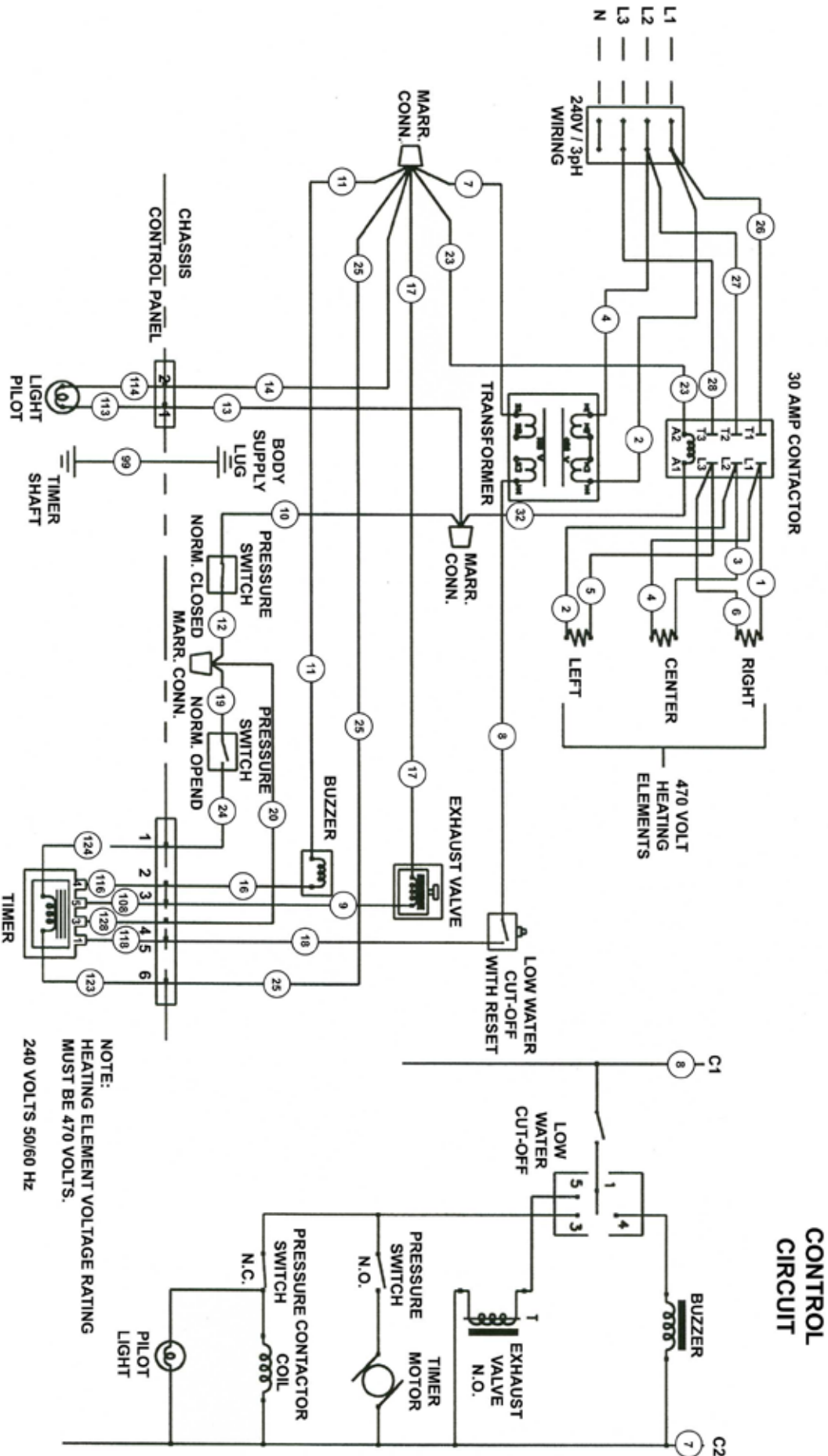

PRINCIPLES OF OPERATION

NO.	PART NO.	DESCRIPTION
1	10-1799	TRUSS HD. TYPE A SCREW
2	10-3453	ELBOW, STREET
3	10-3539	BUSHING, REDUCING
4	10-4710	CHECK VALVE, SWING TYPE
5	10-4419	ELBOW 90° - COMPRESSION 3/8 x 1/2 IPS MALE
6	C95-3848	BRACKER
7	B10-0959	HOSE, RINSE & FILL
8	A09-4848	GOOSNECK

MARKET FORGE 35 GARVEY ST., EVERETT, MA 02149

ASSEMBLY - RINSE HOSE & FILL UNIT FOR SB-ST-E

10-24-77

95-3847

C

C

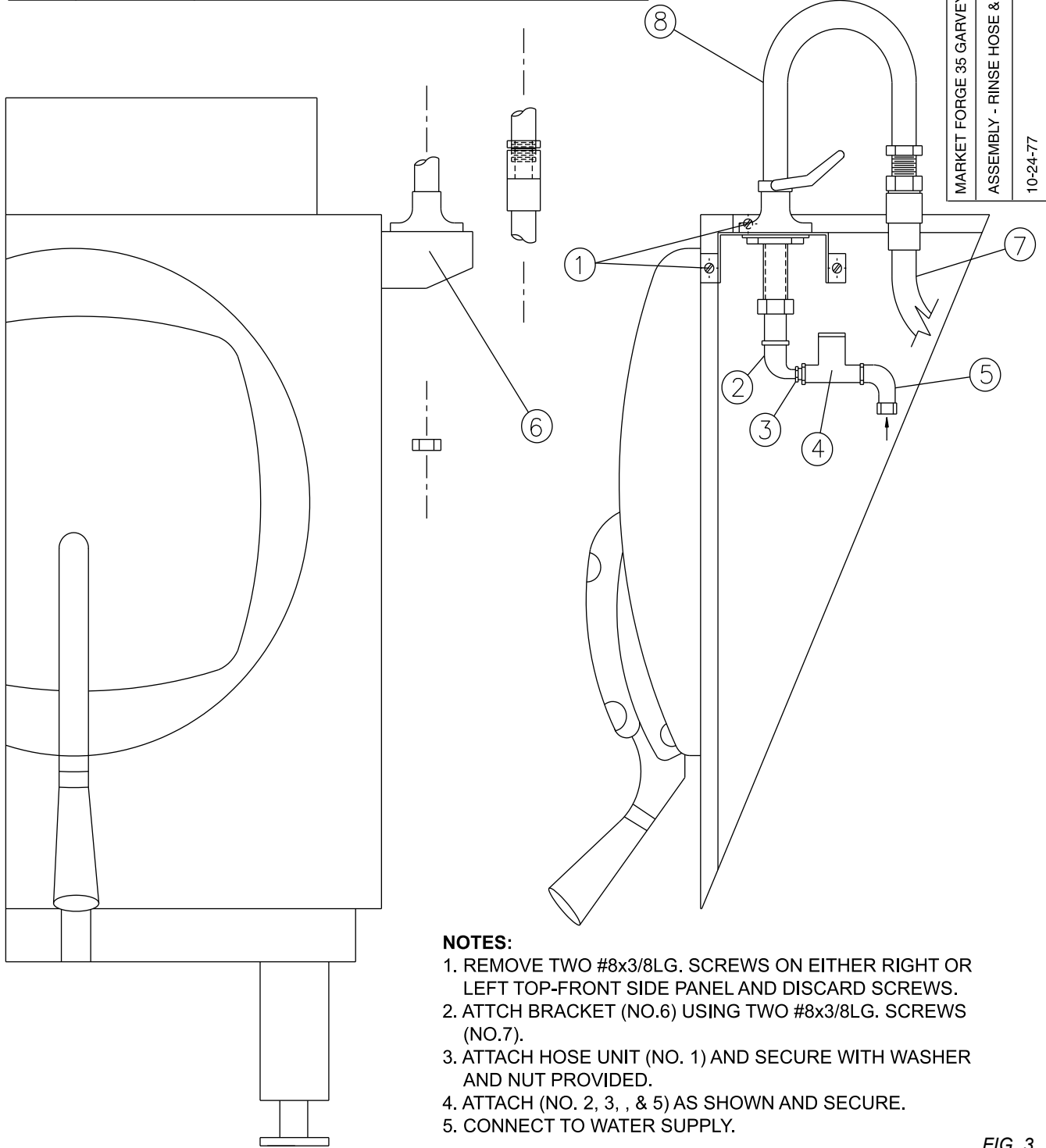

NOTES:

1. REMOVE TWO #8x3/8LG. SCREWS ON EITHER RIGHT OR LEFT TOP-FRONT SIDE PANEL AND DISCARD SCREWS.
2. ATTCH BRACKET (NO.6) USING TWO #8x3/8LG. SCREWS (NO.7).
3. ATTACH HOSE UNIT (NO. 1) AND SECURE WITH WASHER AND NUT PROVIDED.
4. ATTACH (NO. 2, 3, , & 5) AS SHOWN AND SECURE.
5. CONNECT TO WATER SUPPLY.

FIG. 3

PRINCIPLES OF OPERATION

PREHEATING:

Before each Initial operation of cooker and at any time when compartment is cold, a 5 to 8 minute preheating period is required. To preheat cooking compartment. Proceed as follows:

1. Close door and lock in position by placing door handle tongue (Fig. 4 No. 4) under roller on drain casting (Fig. 4 No. 5) press downward on door handle until door is secured
2. Set minute timer (Fig. 4 No. 7) to 5 minutes by turning past 10 and back to 5 to ensure proper setting. Indicator light will come on.
3. When preheating is ended (approximately 5 minutes) and buzzer sounds. turn timer to OFF and allow pressure to return to 0 PSI on pressure gauge (Fig. 4 No. 8).
4. Open compartment door slightly by pulling up on latch handle (fig. 4. No. 6) to allow remaining vapor to escape before raising door to full open position.

WARNING: DO NOT LEAVE HAND ON HANDLE WHILE EXCESS VAPOR IS ESCAPING. SCALDING OF HAND MAY RESULT.

Once the preheating cycle is completed, the cooker compartment may be loaded. The following procedures should be followed:

1. Insert the pans of food into the pan support located on the right and left side of the cylinder.
2. Close the door and lock in position by placing the door handle tongue under the roller on the drain casting (refer to figure 4). Press downward on the door handle until the door is secured.
3. Set the timer for the desired cooking time (refer to *Facts on Parade*) by timing the timer past the desired setting and then back. NOTE: The timer will not start until the unit is at a minimum of 9 PSI as indicated on the pressure gauge.
4. At the completion of the required cooking cycle, steam will automatically exhaust. When the pressure reaches zero PSI on the pressure gauge, the cooker compartment door can be released by pulling on the door latch handle. The operator should allow a few seconds for the remaining vapor to leave the cylinder before completely opening the door. To stop the buzzer, turn the timer to the OFF position.
5. The next step is to remove the cooked food, add any desired seasoning and transfer it to - the serving area. If perforated pans are used, they should be underlined with a solid pan.
6. Check the' water level in the cooker before starting 'another cooking cycle. The water should be at the six quart level. **NOTE:** If the unit is operated with an insufficient amount of water the low water cut-off will

shut the unit down. When the required amount of water is added, the unit will be operational again after the LOW WATER CUT-OFF BUTTON is pressed. However, if the unit does not start after pressing the reset button, more time will be needed before the reset button starts the unit. Should a cooking cycle be interrupted by the low water cut off, the food in the process of cooking will be affected. Proper compensation should be made for cooking already performed and a new cook cycle determined. Clean the unit thoroughly at the end of each day the cooker is used. Ensure that the cylinder is left dry and the compartment door is left open.

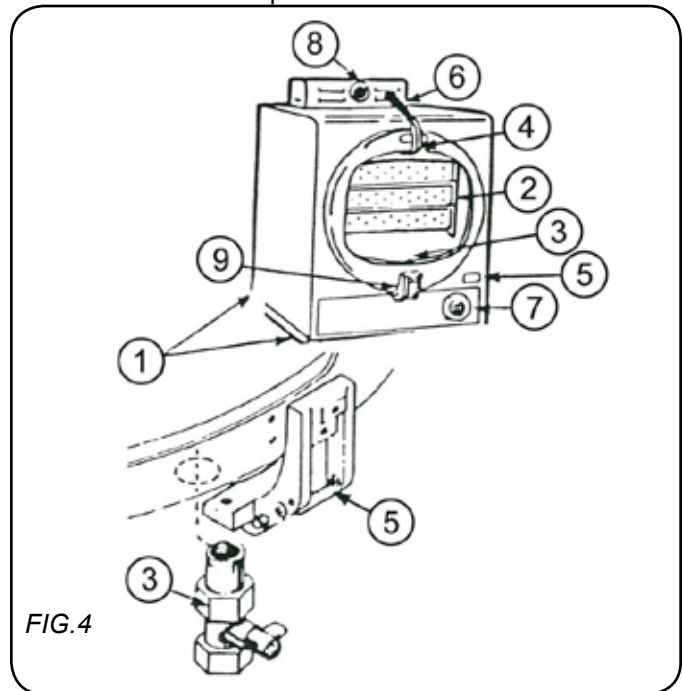

FIG. 4

NOTE: WATER RETAINER & SPRAY HOSE NOT SHOWN.

1	Electrical Connection Box
2	Pan Supports
3	Drain Valve
4	Door Handle Tongue
5	Roller on Drain Casting
6	Door Handle
7	Timer
8	Pressure Gauge
9	Low Water Cut-off Reset Button

FACTS ON PARADE:

1. All foods, except cakes and pastry, can be cooked in a steam cooking unit.
2. Steam cooked meals have greater nutritional value since they retain most of their vitamins and minerals.
3. Because foods are cooked faster by the higher temperatures of steam cooking, they can be prepared closer to serving time, insuring maximum freshness.

PRINCIPLES OF OPERATION

4. Steam cooked food has a higher percent yield - more portions per dollar spent.
5. The principle upon which the steam cooker is based can be likened to the domestic pressure cooker.
6. The principle upon which the steam jacketed kettle is based can be likened to the domestic double boiler.
7. Food may be served from the same pan in which it is steam cooked, thus reducing food breakage since there is no extra handling or transferring of food from cooking pans to serving pans. It also reduces pot, washing tasks.
8. Some important advantages of steam cooking are: - labor saving, reducing operating costs, space saving and the lifting of heavy stock pots is eliminated.
9. Rice and spaghetti products, if thoroughly wet at the start of the cooking process, are very easily prepared.
10. Foods such as potatoes, poultry, seafood and some meats may be blanched in the steam cooker, thus reducing the total cooking time and grease absorption.
11. Fuel is used only when the steam cooking unit is in operation.
12. The steam cooker will loosen foods burned on pans making washing easier.
13. Solid pans are recommended when liquid is to be retained and perforated pans when the liquid is not to be retained.
14. Eggs may be cooked out of the shell if they are to be chopped which eliminates peeling after steaming.
15. Frozen or stale bread may be readied for serving with a small amount of steam.
16. Meats may be sautéed in the kettle before any liquid is added. Sautéing seals in the meat juices and helps to retain flavor.
17. The steam cooker can be opened during the cooking period (by first releasing the steam pressure) to add or remove items. If any time is lost, an adjustment may be made on the timer.
18. All frozen foods must be thoroughly defrosted in order to retain the most satisfactory results.
19. Steam cooking information, including recommended pan size and type, weight per pan, cooking times and pan yields are given on the following pages of this bulletin.

RECOMMENDED COOKING TIMES:

Food Item	Recommended 12" x 20" Perforated Pan	Approx. Raw Weight Per Pan	No. of Pans	Timer Setting in Minutes	Approximate No. Cooked 2oz. (55g) Servings Per Pan*
VEGETABLES, FROZEN, DEFROSTED					
Asparagus, Spears	2.5" 65mm	5# 2.3kg	1 2-3	7-8 8-10	23-25
Beans, Green Regular	2.5" 65mm	5# 2.3kg	1 2-3	7-8 8-10	23-25
Beans, Green French Cut	2.5" 65mm	5# 2.3kg	1 2-3	7-9 9-10	23-25
Lima Beans	2.5" 65mm	5# 2.3kg	1 2-3	6-7 7-8	23-25
Broccoli	2.5" 65mm	4# 1.8kg	1 2-3	5-6 6-7	18-20
Brussels, Sprouts	2.5" 65mm	5# 2.3kg	1 2-3	6-7 8-10	23-25
Carrots, Diced	2.5" 65mm	5# 2.3kg	1 2-3	5-6 7-9	23-25
Cauliflower	2.5" 65mm	5# 2.3kg	1 2-3	7-8 8-10	23-25
Corn	2.5" 65mm	5# 2.3kg	1 2-3	5-6 7-8	23-25
Peas	2.5" 65mm	5# 2.3kg	1 2-3	2-3 4-5	23-25

* All portions are equivalent to approximately 1/2 cup cooked.

PRINCIPLES OF OPERATION

Food Item	Recommended 12" x 20" Perforated Pan	Approx. Raw Weight Per Pan	No. of Pans	Timer Setting in Minutes	Approximate No. Cooked 2oz. (55g) Servings Per Pan*
VEGETABLES, FRESH					
Beans, Wax Green	2.5" 65mm	6# 2.7kg	1 2-3	4-6 7-8	30-35
Broccoli, 1/2" - 3/4" Stalk	2.5" 65mm	6# 2.7kg	1 2-3	4-5 5-6	25-30
Cabbage, Cored - 1/4, 1/6 of head	2.5" 65mm	5# 2.3kg	1 2-3	7-9 10-12	12-20
Carrots, Sliced	2.5" 65mm	9# 4.1kg	1 2-3	6-8 10-12	35-40
Cauliflower	2.5" 65mm	6# 2.7kg	1 2-3	5-6 6-7	30-35
Corn on Cob, Husked	2.5" 65mm	1 dozen	1 2-3	5-6 6-8	12
Potatoes, French Fry Cut	2.5" 65mm	10# 4.5kg	1 2-3	7-9 10-12	50
Potatoes, Regular Cut	2.5" 65mm	10# 4.5kg	1 2-3	13-15 17-19	50
Spinach, Cut and Cleaned	4" 100mm	3# 1.4kg	1 2-3	1-2 2-3	4 oz. - 110g 10-12
Squash, Summer, 1" Sliced	2.5" 65mm	7# 3.2kg	1 2-3	5-7 8-10	30-35
Squash, Winter Diced	2.5" 65mm	9# 4.1kg	1 2-3	7-9 10-12	30-35
Turnip, Diced	2.5" 65mm	5# 2.3kg	1 2-3	10-15 15-20	4 oz. - 110g 20-25
VEGETABLES, CANNED					
Canned, Vegetables	2.5" 65mm	7.5# 3.4kg	1 2-3	4-5 5-7	26-30
MISCELLANEOUS					
Eggs, Out of Shell	2.5" 65mm	4 dozen	1 2-3	3 3-4	48 48
Rice, 1 Gallon Water - 3.78 lts	4" 100mm	4# 1.8kg	1 2-3	17-20 21-25	60/3oz. - 85g Portions
Spaghetti, 1.5-2 Gallons Water - 5.7-7.6 lts	4" 100mm	3# 1.4kg	1 2-3	17-20 21-25	40-45/4oz. - 110g Portions

* All portions are equivalent to approximately 1/2 cup cooked.

PRINCIPLES OF OPERATION

Food Item	Recommended 12" x 20" Perforated Pan	Approx. Raw Weight Per Pan	No. of Pans	Timer Setting in Minutes	Approximate No. Cooked 2oz. (55g) Servings Per Pan*
MEAT - POULTRY - FISH					
Chicken, Cut-Up Blanched	2.5" 65mm	8# 3.6kg	1 2-3	10-15 15-20	15-20 Protein
Chicken, Whole	4" 100mm	(3) 4# 1.8kg	1 2-3	35-40 45-50	25-30 Protein
Fish, Fillets	2.5" 65mm	3# 1.4kg	1 2-3	7-8 8-10	12-15 Protein
Fowl, Whole	4" 100mm	(2) 5# 2.3kg	1 2-3	40-45 45-60	20-25 Protein
Frankforts	2.5" 65mm	5# 2.3kg	1 2-3	1-2 2-3	35-40 Protein
Hamburgers, 3oz. - 85g	2.5" 65mm	5# 2.3kg	1 2-3	8-10 12-15	20-25 Protein
Lobster, 1# Size - 450g	2.5" 65mm	10# 4.5kg	1 2-3	3-6 5-8	10 - 1# 450g
Meatballs** 1oz. Size - 28g	2.5" 65mm	6# 2.7kg	1 2-3	15-17 18-20	20-25 Protein
Meatloaf**	2.5" 65mm	15# 6.8kg	1 2-3	25-30 30-35	50-60 Protein
Pork Chops, loin, 4oz. - 114g with Bone	2.5" 65mm	6# 2.7kg	1 2-3	15-20 20-25	24 Protein
Sausages, 10 per pound - 45g each	2.5" 65mm	6# 2.7kg	1 2-3	14-16 17-19	18-20 Protein
Turkey, on Carcass	4" 100mm	20- 22# 9-10kg	1	75-90	50-60 Protein
Turkey, off Carcass	2.5" 65mm	10- 4.5- 12# 50.4kg	1 2	40-45 45-50	55-65 Protein

* All portions are equivalent to approximately 1/2 cup cooked.

** Raw weight for meatballs and meatloaf includes and extenders and yields 2 oz. - 56g protein plus extenders for 3 oz. - 85g total portion.

PRINCIPLES OF OPERATION

THE FLUE: (FIG. A)

The Flue serves as a protection shield for the Steam Trap (B), safety Valve (A), Exhaust Valve (D), as well as 8 front-facing mount for the Steam Gauge (E). Its servicing of these parts may at times require the removal of the flue. An exploded view drawing is provided to show their proper relative positions within the flue and the method of their assembly to the cooking cylinder.

TO REMOVE THE FLUE: (FIG. A)

1. Unscrew and remove the exhaust silencer (F).
2. Detach the 3/16" copper tube connector (C) from the Steam Gauge (E) at the ferrule nearest the steam gauge. Then, remove the copper tube entirely by freeing it at the other ferrule.
3. Apply inward pressure at either sides of the Flue at points (1) and (2) with a screwdriver. This will collapse the side walls slightly to allow the small fluted sections of sheet metal to clear the edges of the flue opening provided in the outer Shell of the Steam-it. With the restrictions of the flutes removed, the Flue may then be lifted up over the pans it houses.
4. To replace the Flue, reverse the above steps.

STEAM GAUGE:

Located at the top rear of the steam-it and mounted into the forward face of the flue for visibility, the steam gauge registers the pressure within the steam-it cooking chamber. To replace this unit it is necessary to disconnect the 3/16" copper tube connector and remove the two nuts holding the gauge framework in place.

STEAM TRAP:

The steam trap is located within the flue at the top rear of the steam-it. It has the very important automatic, dual function of exhausting all cold air from the cooking compartment and making a suitable seal to allow a pressure build-up of live steam during the cooking cycle. Failure of this unit to operate properly will result in uneven cooking.

HOW IT WORKS:

With the introduction of steam into the cooking compartment, the cold air escapes through the steam trap. When sufficient generated steam displaces the cold air, it passes through the steam trap, and the thermostatic element becomes heated and expands to "make" a seal against the seat. This action encloses the live steam within the cooking compartment and allows a steam pressure build-up to occur.

TROUBLE TEST AND REMEDIES:

The first indication of defective steam trap operation will usually be evidence by uneven cooking. If working properly, the steam temperature will be even and cooking will be uniform through the cooking compartment. Trouble may occur either through premature closing of the steam trap before all the cold air has been exhausted or by its failure to close sufficiently to enable a proper steam pressure build-up. Either case warrants the replacement of the steam trap.

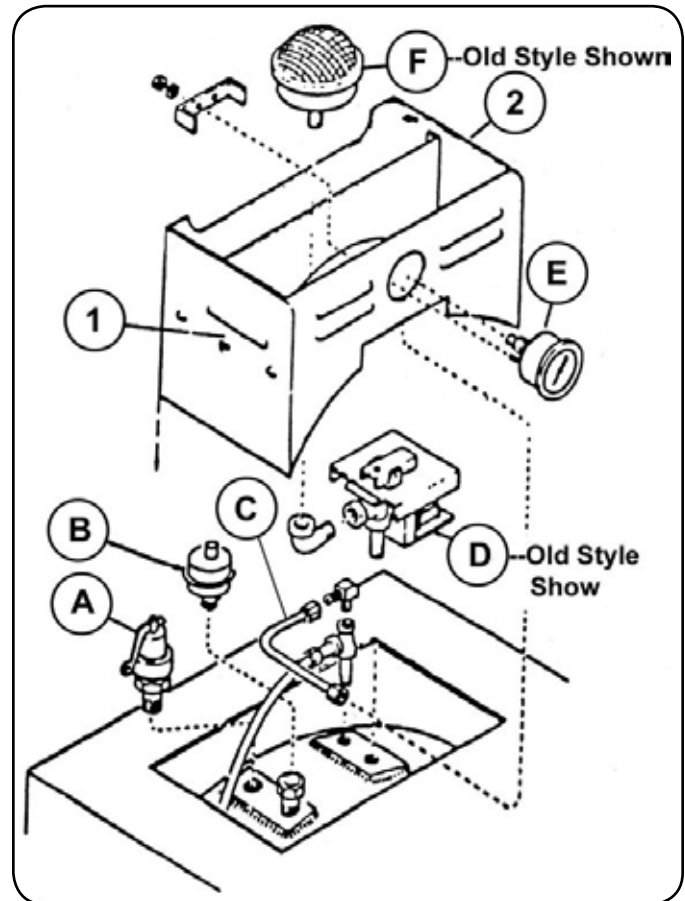

FIG. A FLUE REMOVAL ITEMS:

- | | |
|-------|------------------------------|
| A. | Safety Valve |
| B. | Steam Trap |
| C. | 3/16" Copper Tube Connector |
| D. | Exhaust Valve |
| E. | Steam Gauge |
| F. | Exhaust Silencer |
| 1 & 2 | Flue Release Pressure Points |

MAINTENANCE

PREVENTIVE MAINTENANCE:

This section contains both preventive and corrective maintenance information. Preventive maintenance may be performed by maintenance personnel at the establishment in which the cooker is installed. It is recommended that user personnel never attempt to make repairs or replacements to the equipment without the assistance of authorized service agent.

CAUTION: UNDER NO CIRCUMSTANCES SHALL HARDWARE (OR PARTS) BE REPLACED WITH A DIFFERENT LENGTH, SIZE OR TYPE OTHER THAN SPECIFIED IN THE PARTS LIST. THE HARDWARE USED IN THE STEAM-IT COOKER HAS BEEN SELECTED OR DESIGNED SPECIFICALLY FOR THEIR APPLICATIONS AND THE USE OF HARDWARE OTHER THAN THOSE SPECIFIED MAY DAMAGE THE EQUIPMENT AND WILL VOID ANY WARRANTY.

WARNING: THE ELECTRIC POWER SUPPLY MUST BE DISCONNECTED PRIOR TO PERFORMING REPAIR/SERVICE WORK ON THE MODEL SB-ST-E ELECTRIC STEAM-IT PRESSURE COOKER DISASSEMBLY AND CLEANING

The door assembly must be removed from the cooker compartment for weekly cleaning. Though no tools are needed, care in following procedure is necessary to insure that the door will pass through the compartment opening.

1. With cooking compartment door open, lift pan supports up and forward to disengage from mounting studs. Remove from compartment. .
2. Disengage left and right ends of door seal spring by counter-acting the force of the door lift spring with one hand while disengaging studs with the other hand.
3. Push door lift springs to the rear and off studs.
4. Rotate the door assembly out through the door opening, door handle first.
5. Inspect door gasket for cleanliness and wear. If food soil has become lodged behind the gasket or the gasket is torn, push it off perimeter of door and clean with mild detergent-water solution, or replace as needed. A gasket which is stuck to the door is easily removed by first soaking the entire door in hot soapy water. To assure a pressure seal, the gasket must be cleaned of soil and scale, and be free of breaks.
6. Replace gasket on door and reassemble door assembly in compartment. Open and close door several times to check for correct operation and tight seal of door in closed position.

DOOR ASSEMBLY:

The door assembly consists of the door latch and the latch fulcrum assembly. All parts are replaceable as shown in figure 17, Door Assembly Figure 16, Door Handle assem-

bly Figure 15.

GASKET REPLACEMENT:

The door gasket (Figure 16, item 6) is readily replaced by first removing the door assembly from the cooking compartment as explained in disassembly and cleaning

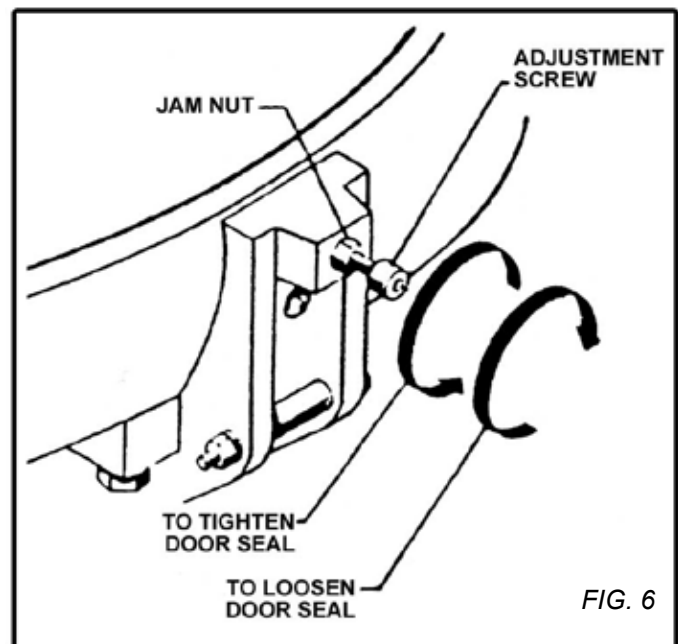
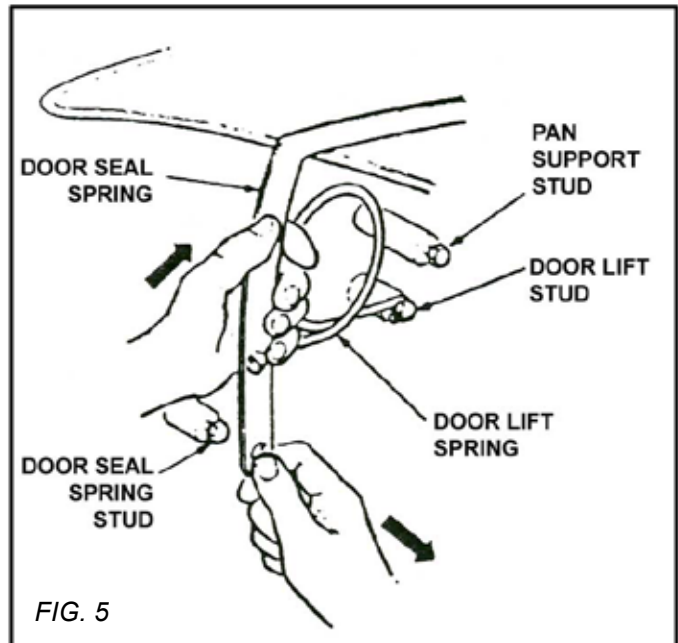

instructions. The worn gasket is removed in the same manner as described for cleaning and a replacement substituted. A new gasket which is difficult to stretch onto the door can be made pliable by first soaking it in hot soapy water. Remounting the door in the compartment completes the replacement.

NOTE: The critical function of the makes it imperative that the in good condition. For this is recommended that at least gasket be kept at all times door seal gasket be reason it one spare.

MAINTENANCE

DOOR SEAL TENSION ADJUSTMENT:

An adjustment screw is built into the door anchor and fulcrum assembly to allow compensation for normal variation in gasket thickness caused by wear. The adjustment screw is shown in Figure 6. If steam escapes from around the door, sealing tension against the door opening can be increased by loosening the 1/4-20 jam nut and turning the socket head adjustment screw counterclockwise with an allen wrench. Installation of a replacement door gasket may result in excessive door latching tension and require clockwise adjustment of the screw. Trial and error will achieve the screw adjustment which both seals the door against the compartment opening yet allows door latching with only moderate force applied to the handle. The final position is set by holding the cap screw with an allen wrench while tightening the 1/4-20 jam nut.

DOOR LIFT SPRING REPLACEMENT:

Should either spring become damaged, it is necessary to replace both left and right springs as a set (Figure 16). The door assembly is removed from the cooking compartment as explained in the Disassembly and Cleaning Instructions. Springs are installed by removing spring bearings (2), screws (1), and worn springs (3 and 4) and mounting replacements. Springs are marked with tabs indicating the left and right side replacement springs for installation on the appropriate side as viewed from the front of the compartment.

EXTERIOR PANEL REMOVAL:

Access to all internal plumbing assemblies is from the top and front of the Steam-It cabinet. Whenever internal repairs or replacements are required, the applicable panels must first be removed. These parts are shown in Figure 14. The following procedure is required for removal of exterior panels.

1. Raise the cooking compartment door.
2. Remove screws (7) in lower front panel (11) and timer knob
3. Slide lower front panel (11) down from cylinder and lift off.
4. To gain access to terminal block (for primary power), remove screws (1) securing terminal box cover to side panel.

STEAM EXHAUST VALVE AND TRAP REPLACEMENT:

The components of the steam exhaust valve assembly, trap, safety valve, silencer, pressure gauge and associated plumbing and hardware are replaced by first removing flue assembly and pressure gauge. To remove flue assembly proceed as follows:

1. Unscrew and remove exhaust silencer.
2. Detach the 3/16" copper tube connector from the pressure gauge at the ferrule nearest the pressure gauge. Then, remove the copper tube entirely by freeing it at the other ferrule.

3. Apply inward pressure at either side of the flue with a screwdriver. This will collapse the side walls slightly to allow the small fluted sections of the sheet metal to clear the edges of the flue opening provided in the outer shell of the Steam-It. With the restrictions of the flutes removed, the flue may then be lifted up over the components.
4. Replacement of safety valve, trap plumbing and exhaust valve assembly (as required) may now be made. The components of the steam exhaust valve assembly.

CAUTION: IF THE WATER SUPPLY IS KNOWN TO BE HARD OR CORROSIVE, A SOURCE OF THREADED WATER SHOULD BE USED. CORROSION MAY ALSO OCCUR IF WATER IS NOT DRAINED DAILY. DO NOT USE DISTILLED WATER.

MARKET FORGE SB-ST-E MARINE STEAM-IT MUST BE CLEANED ONCE A DAY!

DAILY CLEANING: Remove pan supports by lifting the front up and off the stud. Pull back of pan support forward and off stud. Wash with mild detergent and water. Rinse and dry thoroughly.

CAUTION: DO NOT USE STRONG DETERGENT OR ABRASIVE CLEANERS. PITTING OF ALUMINUM INTERIOR WILL OCCUR.

WEEKLY CLEANING: Remove the door. Raise the door to a fully open position and disengage the door spring from each of the door spring studs. Do this by counteracting the force of the door lift spring with one hand while working the end of the door spring off the door assembly with the free hand. Do this on both side of the door assembly. When the ends of the door spring have been completely freed from their respective door spring studs, the door lift springs on either side of the door assembly can easily be slipped off their studs. All Equipment is located on the top and at the back of the SB-ST-E Cooker ONLY. Check the valve. Lift the handle on valve when SB-ST-E is under pressure. Steam should escape.

NOTE: Dirty water may escape for a few seconds, but then the steam should flow freely.

Steam trap should first allow air to escape and then slowly close as all air is forced out of the compartment. The sound of air escaping is quite noisy, but subsides once steam pressure is built up and cooking takes place. If steam trap does not close, it should be replaced. Exhaust silencer must be cleaned by rinsing in mild detergent and water or changed whenever clogged.

Your particular unit may be equipped with a different trap - old style or new style. Replace steam traps will be of the new style. Do this weekly if using new style.

MAINTENANCE

In addition to the daily cleaning it is necessary to clean the air intakes on a weekly basis. Air intakes provide necessary cooling air to the internal components. They are generally located on the rear and sides of the equipment.

CLEANING EXHAUST SILENCER:

The exhaust silencer should be removed and cleaned periodically. As the cooking chamber is exhausted of steam through the silencer, impurities can build up from food particles. Cleaning should be frequent enough to prevent clogging to occur. For this reason, the exhaust silencer is made easily accessible and simple to remove.

To Clean:

1. Remove the one piece exhaust silencer from the unit by unscrewing it in a counterclockwise direction.
2. Clean the silencer by sloshing it in hot soapy water and rinse in clear water. If dirt has clogged the silencer presoak it in an alkaline cleaning solution.
3. After cleaning, stand the silencer on edge to allow it to drain.
4. Screw it back into the elbow of the exhaust valve counterclockwise.

CLEANING TROUBLE-SHOOTING GUIDE (STAINLESS STEEL):

Routine Cleaning:	Soap, ammonia or detergent with hot water. Clear water will rinse.
Overall "straw" color film:	Caused by water and detergent residue. Use mild phosphoric acid-type cleaner.
Stubborn spots, stains and baked on splatter:	Allchem concentrate, samae, cameo, copper cleaner, liquid or paste Nu-Steel or Du-Bois temp, gobbard's or revere stainless cleaner, scouring powder (rinse thoroughly), steel bright, lumin or zud.
Heavy tinting, or heavy discoloration:	Penny-brite, copper-brite, DubBois temp, tarnite, gobbard's or revere stainless cleaner.
Hard water spots, scale:	Vinegar.
Grease and oil:	5% oxalic acid, 5% sulfamic acid, 5-10% phosphoric acid, dilac, oakite #33, texo 90, texo 91, or organic solvents (acetone, benzene, alcohol, trichlorethane, chloroethane n. u.).

NOTE: Clear water rinsing followed by wipe-down with soft cloth is recommended after all cleaning procedures.

These recommendations are based on tests and studies done by the Armco Research Center and provided through the courtesy of American Iron and Steel, Institute's Stainless Steel, Producer's Committee.

WARNING:
DO NOT HOSE DOWN UNIT AS IT CONTAINS ELECTRICAL COMPONENTS.

ITEM NO.	FIG. 7 Cooker Compartment DESCRIPTION	PART NO.
1	BASEPLATE ASSY - FIXED	95-3301
2	TRANSFORMER 440/480 V UNITS	10-5234
3	NO. 10 LOCKWASHER STAINLESS STEEL	*
4	NO. 10-32 x 1/2" BINDING HD SCREW STAINLESS STEEL	*
5	LEAD ASSY, TRANSFORMER	95-3394
6	PLUG BUTTON	10-3095
7	PLATE -TREM, STRIP SUPPORT	95-3289
8	COVER - TERM. BOX	95-3484
9	NO. 8-32 x 1/8" RD HD SCREW STAINLESS STEEL	*
10	GROUND LUG	10-6969
11	CONNECTOR	95-3500
12	REDUCING WASHER	10-6967
13	JUNCTION BOX COVER	95-3489
14	TERM. STRIP SECTION	10-6962
15	TERM. STRIP END SECTION	10-6963
16	BASEPLATE SUB ASSY - MOVABLE	95-3302
17	CONTACTOR 280V, 50/60 Hz CYCLE, COMPLETE	10-5466
	CONTACTOR 230/240V, 50/60 Hz CYCLE, COMPLETE	10-5467
18	COIL 208V, 50/60 Hz CYCLE	10-5470
	COIL 230V, 50/60 Hz CYCLE	10-5471
19	LOW WATER CUT-OFF	10-5990
20	NO. 6-32 x 1/4" TRUSS HD SCREW STAINLESS STEEL	*
21	CONNECTOR	10-6966
22	PRESSURE CONTROL - OPEN ON RISE	95-0998
23	PRESSURE CONTROL - CLOSE ON RISE	95-0999
24	NO. 10-32 x 1/2" RD SCREW STAINLESS STEEL	*
25	ADAPTER - STRAIGHT 1/4" OD - 1/2" IPSM	10-2904
26	ADAPTER - TEE 1/8" IPS - 1/4" OD - 1/4" ODM	10-3426
27	REDUCING BRUSH 1/4-1/8 IPS	00-3652
28	TUBE	95-3305
29	TUBE - PRESSURE CONTROL	95-3304
30	UNION - COMPR. FITTING 1/4 OD	10-1154
31	TUBING - STEAM PRESSURE LINE	95-3387
32	TIMER, 60 MINUTE	95-3404
33	BRACKET, TIMER	95-3277
34	KNOB, DIAL	10-6307
35	BRACKET - PILOT LIGHT	95-3403
36	LOCK WASHER	10-2509
37	HEX NUT 10-32	10-2340
38	PILOT LIGHT	10-6669
39	EXHAUST SILENCER	10-4963
40	CAGE, ELECTRIC WIRE	95-0483
41	CONDUIT - NIPPLE	10-6964
42	SPEEDNUT 6-32	10-4110
43	WASHER	95-0463
44	NO. 10-32 x 1/8 HEX SOCKET HD CAP SCREW STAINLESS STEEL	*

45	DOOR HANDLE ASSY - COMPLETE	95-0144
46	DRAIN PLUG ASSY - COMPLETE	95-0154
47	HANDLE BUMPER	10-0226
48	NO. 8-32 x 1/8 BINDING HD SCREW TY 'Z' STAINLESS STEEL	*
49	SAFETY VALVE	10-4636
50	STEAM TRAP	10-6156
51	ADAPTER	10-6158
52	OLD STYLE - EXHAUST VALVE 208V, 60 Hz CYCLE COMPLETE	95-0944
	OLD STYLE - EXHAUST VALVE 230/480V, 60 Hz CYCLE COMPLETE	95-0945
	OLD STYLE - EXHAUST VALVE 230V, 50 Hz CYCLE COMPLETE	95-0946
	OLD STYLE - EXHAUST VALVE 208V & 230V, 50 Hz CYCLE COMPLETE	95-0946
52A	NEW STYLE - EXHAUST VALVE (NOT SHOWN)	N/A
	NEW STYLE - EXHAUST VALVE 220/240V, 50/60 Hz	09-6545
	NEW STYLE - EXHAUST VALVE 208V, 50/60 Hz	09-6536
53	NIPPLE, 1/8 IPS	10-3852
54	ELBOW, 1/8 IPS ST'D 90O	10-3851
55	BUZZER - COMPLETE	10-6665
56	FULCRUM & CRAIN ASSY	95-0115
57	5/16-18 x 1 1/2" SQ HD SCREW STEEL CAD. PL.	*
58	5/16 FLAT WASHER, 1/8 ID x #16 GA ST'D STEEL CAD. PL.	*
59	HEX NUT 5/16-18 ST'D STEEL CAD. PL.	*
60	CONNECTOR, 1/8-90O	10-5036
61	FRONT LOWER PANEL ASSY	95-3388
62	NAMEPLATE PANEL 60 CYCLE	10-6595
63	NAMEPLATE PANEL 50 CYCLE	10-7096
64	ROD	95-0466
65	PAN INSULATION	95-0465
66	STUD	10-1937
67	PAN RACK ASSY - RIGHT SIDE	95-2545
68	PAN RACK ASSY - LEFT SIDE	95-2546
69	1/4 SHAKEPROOF INT. TOOTH LOCKWASHER STAINLESS STEEL	*
70	1/4-20 x 3/4" RD HD SCREW STAINLESS STEEL	*
71	1/4-20 x 1/84" HEX HD SCREW STAINLESS STEEL	*
72	CASE - TOP FONT UPPER	95-3131
73	CASE - LEFT SIDE	95-3140
74	CASE - RIGHT SIDE	95-3141
75	CASE- BACK	95-3490
76	NO. 8 x 1/8" PHIL. TRUSS HD SCREW TY 'A'	*
77	FLUE ASSY	95-3135
78	PRESSURE GAUGE	10-0883
79	TUBING PRESSURE GAUGE	95-3270
80	DOOR ASSY, COMPLETE	95-0124
81	BODY ASSY 208V & 236V	95-0478
	BODY ASSY 470V	95-0479
82	RETAINER, WATER (NOT SHOWN)	91-2601
83	ASSY, HOSE FILL (NOT SHOWN)	95-3849
84	FOOT, FLANGED 4" (NOT SHOWN)	91-2449

* THESE PARTS ARE AVAILABLE AT LOCAL HARDWARE, PLUMBING AND ELECTRICAL OUTLETS. IF NOT OBTAINABLE, SPECIAL PRICES WILL BE QUOTED BY MARKET FORGE UPON REQUEST.

ILLUSTRATED PARTS LIST

FIG. 8 Door Handle Assembly

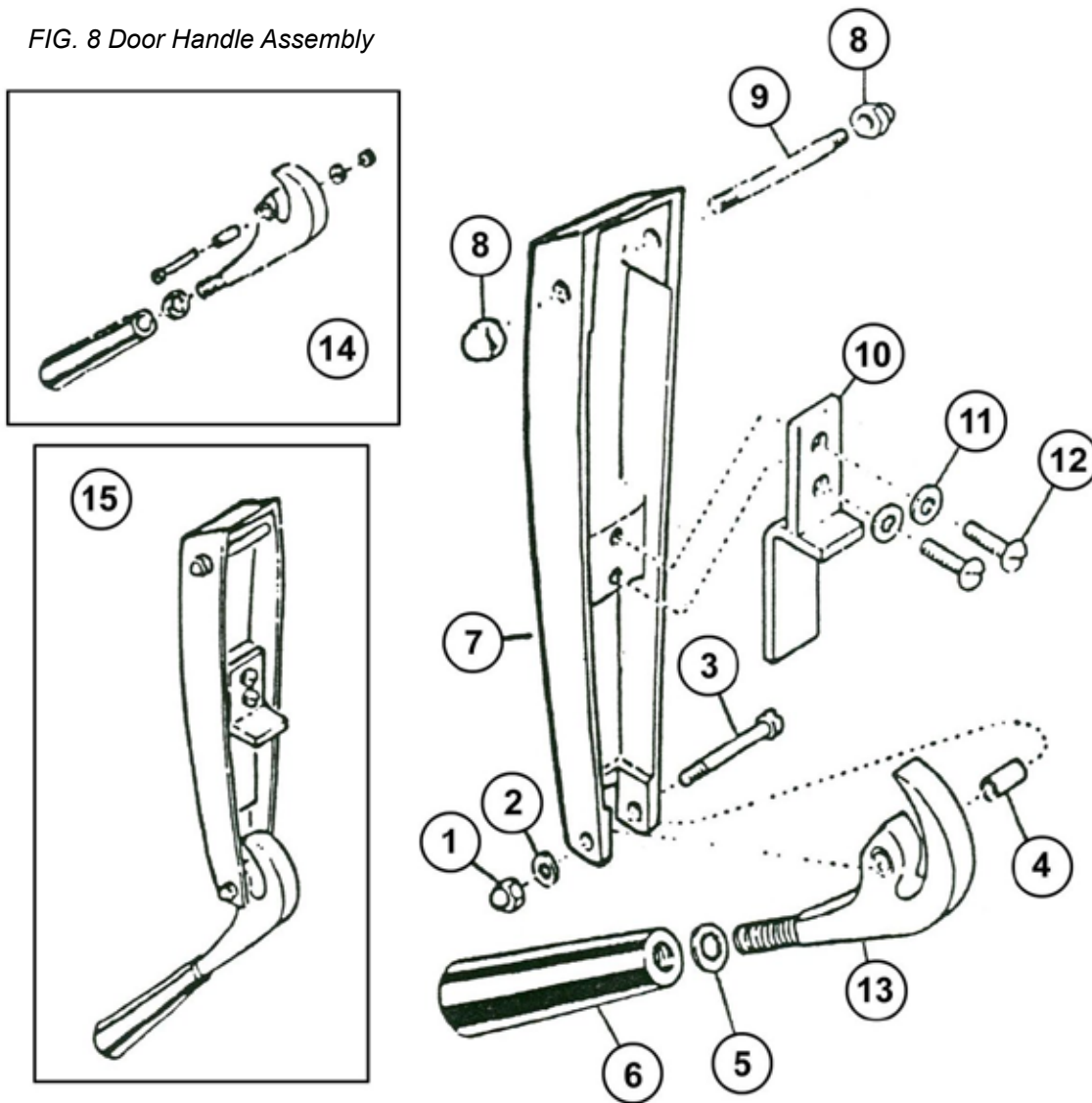

ITEM NO.	DESCRIPTION	PART NO.
1	NO. 10-32 ACORN NUT	10-2318
2	#10 SHAKEPROOF LOCKWASHER	10-2514
3	LOCKING SCREW	10-1999
4	BEARING SPACER	95-0120
5	3/8" SHAKEPROOF LOCKWASHER	10-2517
6	DOOR LOCK KNOB	10-0050
7	DOOR HANDLE CASING	95-0134
8	1/4"-20 ACORN NUT	10-2359
9	DOOR HANDLE BEARING STUD	95-0658
10	DOOR HANDLE BEARING BRACKET	95-0659
11	1/4" SHAKEPROOF LOCKWASHER	10-2513
12	1/4"-20 x 5/8" RD HD SCREW *	10-1731
13	DOOR LOCK ASSY	95-3223
14	DOOR LOCK KNOB ASSY (ITEMS 1-6 PLUS 13)	95-0145
15	COMPLETE DOOR HANDLE ASSY (ITEMS 1-13)	95-0144

* OBTAIN AT LOCAL HARDWARE STORE.

ILLUSTRATED PARTS LIST

THE COOKER DOOR ASSEMBLY

The door of the Cooker has been engineered to establish a positive method of sealing the steam pressure within the cooking cylinder. As steam pressure builds up within the cylinder, the door seal will tend to become more positive. However, the door should be adjusted to make a good initial seal between the door gasket and the door opening without the added assistance of "internal cylinder steam pressures. With the simple action of securing the door handle down in a locked position, the door gasket should be sufficiently compressed against the door opening, all the way around, to prevent any steam leakage from occurring.

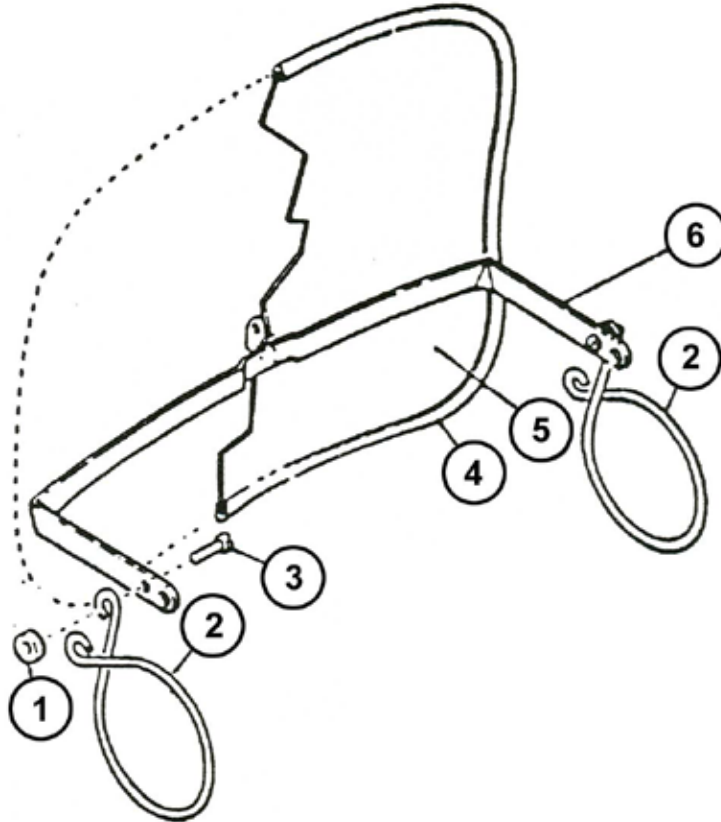

ITEM NO.	FIG. 9 Door Assembly DESCRIPTION	PART NO.
1	PIVOT SPRING BEARING	10-6765
2	DOOR LIFT SPRINGS - PAIR	10-2718
3	10-32 MACHINE SCREW 1/2" LONG	10-1776
4	DOOR GASKET	10-2666
5	DOOR & DOOR SPRING ASSY	95-3204
6	DOOR SPRING	95-0127
--	COMPLETE DOOR ASSEMBLY (ITEMS 1-6)	95-0124

FULCRUM & DRAIN ASSEMBLY:

The Fulcrum and Drain Assembly is located at the lower front of the cooking cylinder and furnishes a sturdy anchorage for the door locking system of the door handle. Also provided in this assembly is a means of adjustment for the door seal. The drain port and drain plug provide a means of discharging accumulations of water from the cooking cylinder.

ROLLER ASSEMBLY:

Built Prior to 10/85 (Items 5, 6, 7, 8, & 9.)

Built after 10/85 (Items 2, 8, 9, 13, & 14.)

The Roller Assembly must be kept free-rolling at all times. Should this assembly be allowed to become frozen due to lack of lubrication undue strain will be put on the door handle and the fulcrum casting while the door is being locked. Use only a dry lubricant such as graphite, as oil or grease will tend to attract dirt to this area.

ILLUSTRATED PARTS LIST

FIG. 10 Old Style Fulcrum & Drain Assy

ITEM NO.	DESCRIPTION	PART NO.
1	FULCRUM & DRAIN CASTING	95-0116
2	1/4-20 x 3/8 HELICOIL	10-3111
3	1/4" SHAKEPROOF WASHER	10-2513
4	1/4-20 CAP SCREW, 1/8" LG. *	10-1790
5	10-32 ACORN NUT	10-2318
6	#10 SHAKEPROOF LOCKWASHER	10-2518
7	BRONZE BEARING	95-0198
8	BEARING SPACER	95-0120
9	10-32 MACHINE SCREW, 1.5" LG.	10-1999
10	ROLLER ASSY (ITEMS 5-9)	95-0149
11	1/4-20 MACHINE SCEW, 3/4" LG. *	10-1763
12	1/4-20 ALLEN SET SCREW	10-2087
13	1/4-20 JAM NUT	10-2358
14	1/4-20 x 3/8 HELICOIL	10-3116
--	COMPLETE FULCRUM ASSY (ITEMS 1-14)	95-0115
15	DRAIN PLUG HANDLE	95-0658
16	DRAIN PLUG	10-2227
17	1/4-20 ACORN NUT	10-2359
18	DRAIN & PLUG HANDLE ASSY - COMPLETE	95-2604

* OBTAIN AT LOCAL HARDWARE STORE.

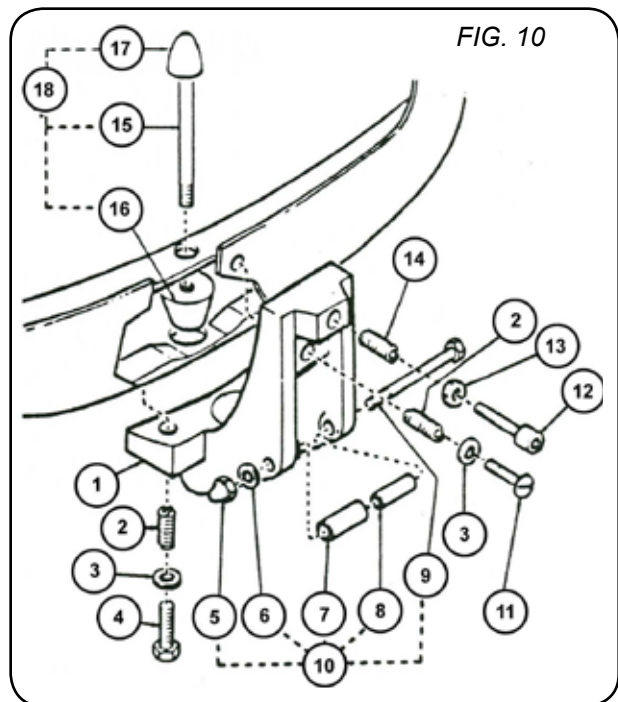
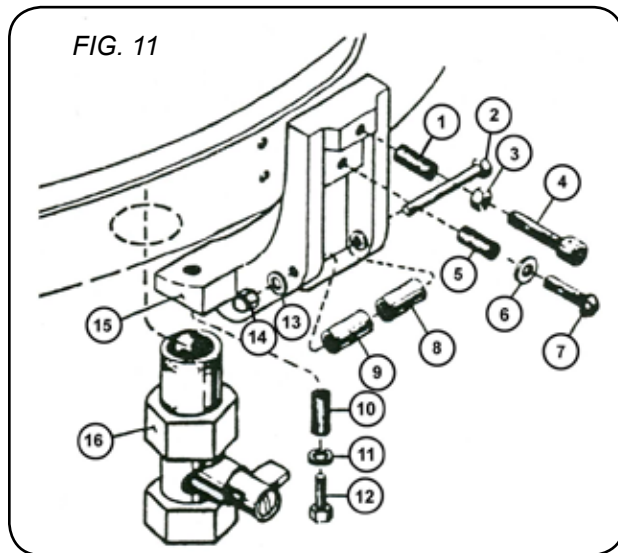

FIG. 11 New Style Fulcrum & Drain Assy

ITEM NO.	DESCRIPTION	PART NO.
1	1/4-20 x 3/8 HELICOIL	10-3116
2	10-32 MACHINE SCREW, 1 3/8" LG.	10-1999
3	1/4-20 FULCRUM NUT	10-2358
4	1/4-20 ALLEN SET SCREW	10-2087
5	1/4-20 x 3/8 HELICOIL	10-3111
6	1/4" SHAKEPROOF WASHER	10-2513
7	1/4-20 MACHINE SCEW, 3/4" LG. *	10-1763
8	BEARING SPACER	95-0120
9	BRONZE BEARING	95-0198
10	1/4-20 x 3/8 HELICOIL	10-3111
11	1/4" SHAKEPROOF WASHER	10-2513
12	1/4-20 CAP SCREW, 1/8" LG. *	10-1790
13	#10 SHAKEPROOF LOCKWASHER	10-2514
14	10-32 ACORN NUT	10-2318
15	FULCRUM & DRAIN CASTING	95-3850
16	BALL VALVE	10-1041
--	FULCRUM & DRAIN ASSY (ITEMS 1-5)	95-3992

* OBTAIN AT LOCAL HARDWARE STORE.



SAFETY VALVE: The Safety Valve is set to automatically relieve the cooking compartment of excessive pressure build-ups by opening at a point between 15 1/2 lbs. and 16 lbs.

CHECKING SAFETY VALVE: If the Safety Valve should leak continually with a pressure build-up, or should it cause an interruption of the Cooking cycle prematurely (less than 15 1/2 lbs. on the steam gauge), it must be determined to be defective and be replaced. However, the steam gauge should first be checked for accuracy before making this determination. The steam gauge should register absolute zero with no pressure in the cooking cylinder. If the normal zero setting has advanced some what through usage (a characteristic of steam gauges), the amount of advancement from absolute zero must be subtracted from its registered reading 10 determine the true steam pressure.

ILLUSTRATED PARTS LIST

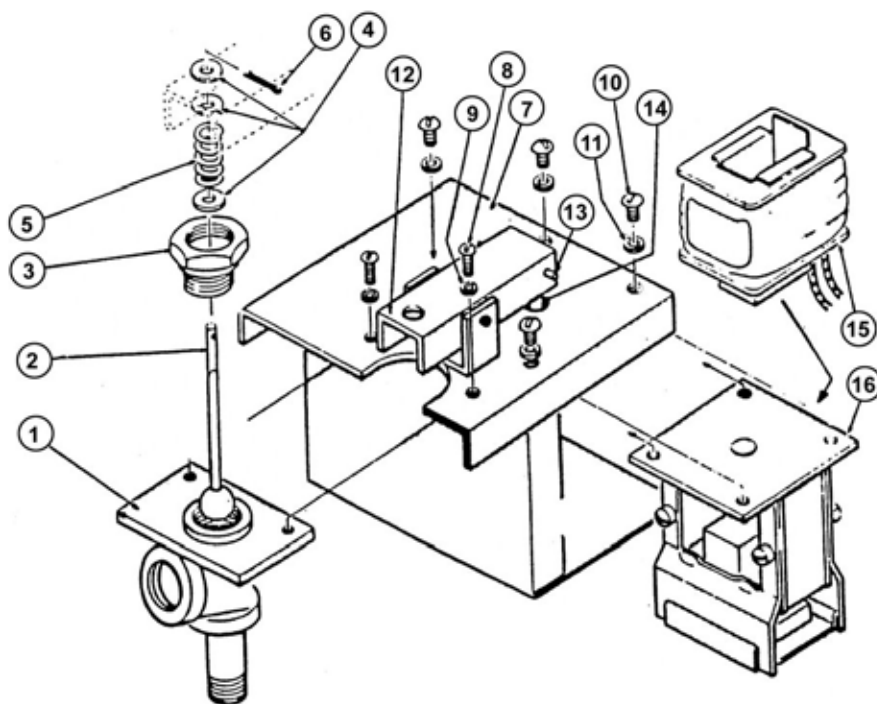

ITEM NO.	FIG. 12 Exhaust Valve DESCRIPTION	PART NO.
1	TEE ASSEMBLY	95-0756
2	BALL & PIN ASSEMBLY	95-0372
3	DIAPHRAGM BODY ASSEMBLY	95-2077
4	NO. 10 FLAT WASHER 3/16" ID x 1/2 OD x 0.086 (CAD. PI)	10-2425
5	SPRING, COMPRESSION	10-4675
6	PIN, COTTER 1/16 x 1/2 STAINLESS STEEL	10-1663
7	SOLENOID BRACKET ASSEMBLY	95-0431
8	NO. 10-32 x 3/8" RD. HD. SREW (CAD. PI)	10-1759
9	NO. 10 LOCKWASHER (CAD. PI)	10-2505
10	1/4-20 x 3/8" RD. HD. SCREW (CAD. PI)	10-1701
11	1/4 LOCKWASHER (CAD. PI)	10-2500
12	CHANNEL	95-0755
13	PIN, ROLL 1/8 x 1-1/8" (CAD. PI)	10-1678
14	PIN, SOLENOID	95-0760
15	COIL - 208V, 60 CYCLE	10-6663
15	COIL - 208V, 50 CYCLE	10-6664
15	COIL - 230V, 60 CYCLE	10-6656
15	COIL - 230V, 50 CYCLE	10-6657
16	SOLENOID - 208V, 60 CYCLE, COMPLETE	10-6662
16	SOLENOID - 208V, 560 CYCLE, COMPLETE	10-6667
16	SOLENOID - 230V, 60 CYCLE, COMPLETE	10-6666
16	SOLENOID - 230V, 50 CYCLE, COMPLETE	10-6660
--	EXHAUST VAVLE - 208V, 60 CYCLE, COMPLETE	95-0944
--	EXHAUST VAVLE - 208V, 50 CYCLE, COMPLETE	95-0947
--	EXHAUST VAVLE - 230-480V, 60 CYCLE, COMPLETE	95-0945
--	EXHAUST VAVLE - 230V, 50 CYCLE, COMPLETE	95-0946
--	ASSEMBLY (ITEMS 1 THRU 6) COMPLETE	95-3197

ILLUSTRATED PARTS LIST

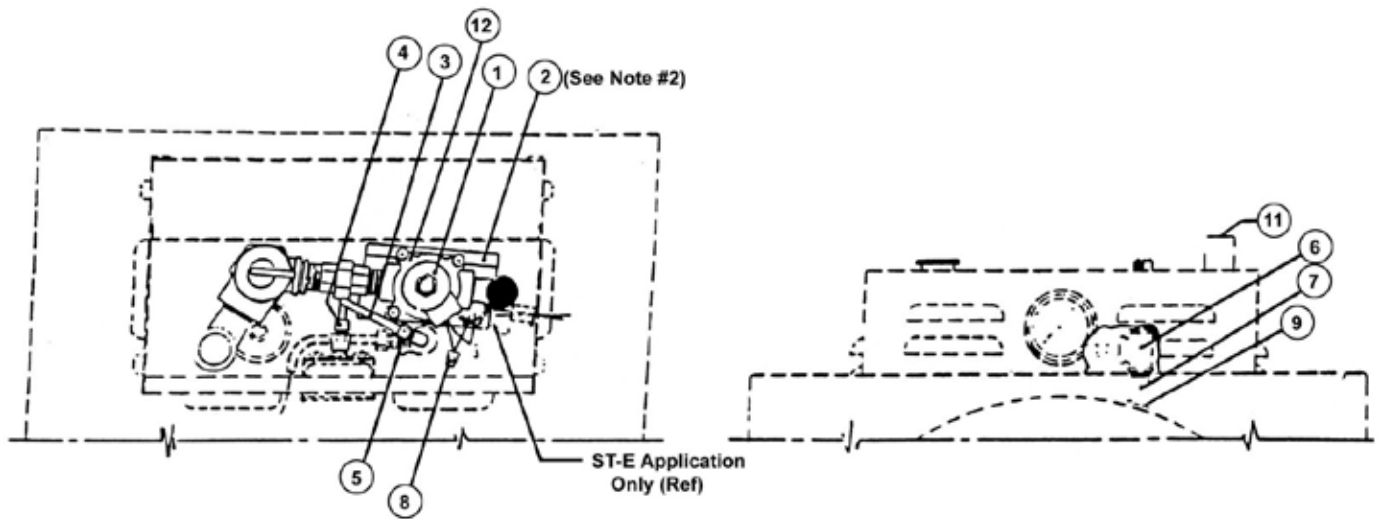

ITEM NO.	FIG. 13 NEW Exhaust Valve, Built after July 1983 DESCRIPTION	PART NO.
1	ASSY PIPLIN EXHAUST, 208-240V, 50/60Hz	C95-3996
2	HEAT DEFLECTOR PLATE	C95-3990
3	TUBING, PRESSURE GAUGE	A95-3270
4	PEM., CORN, BRASS 1/8 IPS x 3/16 OD	10-3361
5	90 DEGREE COMP., 1/8 IPS MALE 3/16 OD	10-3360
6	TEE REDUCING BRASS (EXSITING)	10-3432
7	NIPPLE, BRASS CHR. PL (EXSITING)	10-3420
8	MARR CONNECTOR	10-5143
9	PLUG, COUNTERSINK, 1/4 IPS BR. CHR. PL.	P09-4843
10	PACKING CORRUGATED CARTON (8x8x6)	10-1643
11	SILENCER EXHAUST STEAM-IT	A10-4963
12	EXHAUST VALVE ONLY 220-240V, 50/60Hz	09-6545
12	EXHAUST VALVE ONLY 208V, 50/60Hz	09-6536

TROUBLE-SHOOTING

OLD STYLE BUILT PRIOR TO SEPTEMBER 1980

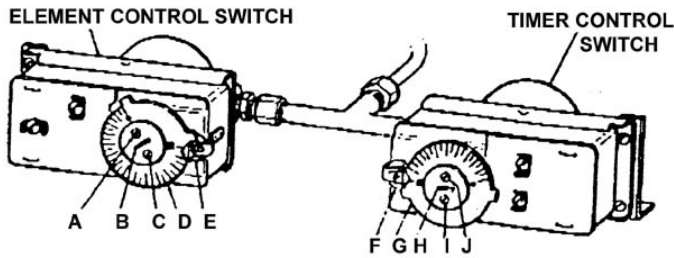

FIG. 14

ELEMENT CONTROL SWITCH: The element control switch, located under the removable front lower panel, just left of center, governs the flow of current to the heating elements to maintain cylinder pressures at a near constant 14 PSI.

HOW IT WORKS: A copper tube extending from the top of the cylinder to the rear portion of the element control switch constantly reflects internal cylinder steam pressure upon to built-in bellows of the element control switch to cause it to open or close an electrical circuit to the contactor coil. With little or no pressure applied to the bellows, the circuit to the contactor will be closed and proving the timer is set to cycle the contactor will click in and current will flow to the heating elements. When the pressure rises to 14 PSI (original factory setting) the bellows will be sufficiently compressed by the steam back pressure to break the circuit to the contactor coil will click out and current flow to the heating elements will cease. When cooling allows the pressure to drop below 13 pounds the bellows will again complete the contactor coil circuit activate the contactor to click in and allow the heating elements to energize. Thus, by working intermittently to open and close the contactor coil circuit the element control switch in effect regulates current flow to the heating elements.

DIAL ADJUSTMENT: Two dial settings determine the operational range of the element control switch. The larger dial (FIG 14, D) determines the maximum build-up of cylinder steam pressure while the smaller dial (FIG 14, E) governs the range of differential between the switch's cut-in and cut-off points.

Should a lower cylinder cooking pressure be desired, adjust the large dial (FIG 14, D) by inserting a screwdriver into slot (FIG 14, B) found at the center by turning it slightly counterclockwise to lower pressure. Clockwise rotation will increase the pressure. Pressure must not be adjusted to exceed 14 pounds as the safety valve is set to automatically open just above this point.

The cut-in and cut-off points of the element control switch may be adjusted by rotating the small screw at the center of the smaller dial (FIG 15, E). Normally factory setting is for a one pound differential between cut-in and cut-off. To increase the range of differential, rotate screw clockwise to decrease the range of differential, rotate the screw

NEW STYLE BUILT AFTER SEPTEMBER 1980

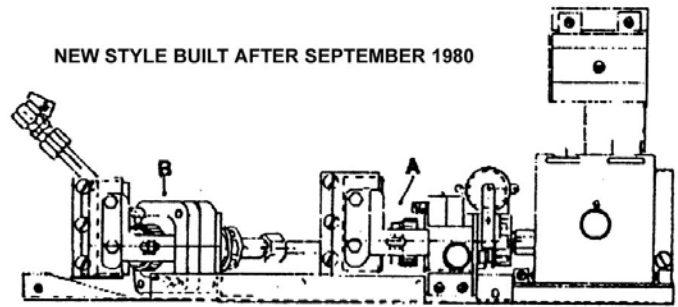

FIG. 15

counterclockwise. Check adjustments through a trial cycle by observing pressure gauge pressure and again when it clicks in after cylinder cooling. The difference on pressure as read on the pressure gauge should, at these points be approximately one pound.

RECALIBRATING ELEMENT CONTROL SWITCH:

The element control switch may be recalibrated should it vary some what through usage from its original factory setting. At the precise moment of contactor "click-out" the dial setting of the element control switch and the steam pressure gauge reading should both be at 14 pounds. A slight override of steam pressure build-up will normally occur and indicate itself on the pressure gauge after the contactor has "clicked-out". This is normal and is not to be interpreted as an element control switch out of calibration.

PRESSURE CONTROL SWITCH (BARKSDALE):

Models built after September 1980 use 2 Barksdale pressure switches in place of the White-Rogers element control switch and the timer control switch.

OPERATING PRESSURE ADJUSTMENT

(BARKSDALE): The operating pressure is determined by setting the right switch (FIG 15, A) at approximately 10 PSI and the left switch (FIG. 15, B) at approximately 14 PSI. Both switches were set at the factory. These settings can be verified by looking through the slot (in the red rectangular) and observing the alignment of the black line inside the white scales on either side of the slot. To readjust turn white knob in approximate direction to raise or lower pressure.

WARNING: Because power must be on to adjust pressure switches, be sure to protect against electrical shock.

Check adjustments through a trial cycle and observe pressure readings on pressure gauge when (FIG. 15, B) clicks off at maximum cylinder pressure and when (FIG. 15, A) clicks on after cooling. Making adjustments as needed being careful not to let switch (FIG. 15, B) pressure be set to exceed 14 pounds. Since the safety valve is set to automatically open just above this point.

TROUBLE-SHOOTING

RECALIBRATING PRESSURE CONTROL

SWITCH: The actuation valve (differential) is factory set and cannot be recalibrated.

LOW WATER CUT-OFF: The low water cut-off is mounted above the timer assembly under the front lower panel with its thermostat bulb extending and inserting into a channel provided for it at the outer edge of the cast-in heating elements. It functions as a safety feature to shut off the complete unit in event the water runs dry.

HOW IT WORKS: If the Steam-It operated with no water or the water has evaporated away, the temperature of the cooking cylinder will rise by heat induction effect the thermostat bulb of the low water cut-off. Electrical current flow will be broken at the low water cut-off and the unit will shut down. With the replacement of water into the cooking cylinder the thermostat bulb will be cooled at the unit will then again be operative after pressing the reset button, more time will have to allowed for further cooling.

NOTE: Should a cooking cycle be started with insufficient water, and interrupted due to safety action of the low water cut-off, the food in the process of cooking will be affected. Proper compensation will have to be made for the cooking performed and with proper amount of water in the cooking cylinder, a new cycle determined and set to complete the process.

TIMER: The timer located at the lower right front of the Steam-It provides a means of manual control. The Steam-It is put into an automatic cycle of cooking with the setting of the timer to any of its calibrated periods of cooking. Its timing cycle however, is automatically delayed by the timer control switch until free venting has occurred and a cylinder pressure build-up to 10 PSI has been reached.

TROUBLE TEST AND REMEDIES: If the timer should fail to operate the STEAM-IT and a check shows all wiring to be in good order, and should the timer control switch be found in good order as ascertained by a continuity check the timer must be regarded as defective and must be replaced. The timer is replaceable only as a complete unit.

TIMER CONTROL SWITCH: The timer control switch, located under the removable front lower panel is right of center, automatically delays the timer count-down at the beginning of the cycle until the Steam-It has fully free-vented out all cold air from within the cooking cylinder and pressure has reached 10 PSI. This delay insures

the timer count only that portion of the cycle when cylinder steam pressure is actually acting on the foods. This, of course is important when processing foods which only required very short periods of cooking time.

HOW IT WORKS: The copper tube which extends the top of the cylinder to the rear portion of the timer control switch constantly reflects internal cylinder steam pressure upon the timer control switch's built-in bellows. While cylinder free-venting is occurring the switch keeps the timer circuit open. After free-venting has terminated and when the cylinder pressure has built-up to approximately 10 PSI the contacts will be forced closed by back-pressure working on the bellows, the timer circuit will be completed and the timer will then start its countdown.

DIAL ADJUSTMENTS: The cut-in point of the timer control switch has been factory set at its maximum setting of 10 pounds and should not be altered unless it is found that the timer does not start until well after 10 pounds of steam pressure has been realized on the pressure gauge. In this case insert a screwdriver into the center slot (FIG. 14, H) of the larger dial (FIG. 14, G) and rotate slightly counterclockwise to adjust timer to start at 10 PSI.

RECALIBRATING TIMER CONTROL SWITCH: Should the timer control switch vary through usage from its original factory setting it may be restored to proper working order by recalibrating.

A visual check of the timer control switch during a trial cycle will quickly determine the need of recalibration. With the timer control switch dial set at 10 pounds (fully clockwise) the timer motor should cut-in when 10 pounds of steam pressure is registered on the steam pressure gauge. By watching the smaller dial (FIG. 14, F) on the timer control switch the cut-in of the switch may be observed and heard to click forward at the moment the circuit is made to the timer motor. At that precise moment the pressure gauge should measure 10 pounds.

CAUTION: If problem develops during the cooking cycle of this electric steam pressure (15 PSI operation) consult the trouble-shooting guide on page 24.

PILOT LIGHT: The pilot light is located at the lower right front of the front panel. This unit is wired to operate when the heating elements are on. The circuit will be broken when the timer returns to the "0" position. Thus, when the pilot light is on and off it signifies that the heating elements are cycling on and off to maintain cooking pressure in the cooking chamber.

TROUBLE-SHOOTING

TROUBLE-SHOOTING GUIDE

POSSIBLE CAUSE	CORRECTION
A. Unit fails to operate at all (no pressure build-up).	
<ol style="list-style-type: none"> 1. Blown fuse. 2. Wiring faulty. 3. Not installed correctly. 4. Element control switch or contactor coil not in circuit. 5. Current not passing through timer to start unit. 	<ol style="list-style-type: none"> 1. Replace fuse. If it blows again, check that source of electricity supply is 60 AMPS. 2. Check all wiring. Replace as needed. 3. Check wiring diagram for correct hookup. 4. Check both elements for continuity. Replace or repair as needed.
B. Unit operated but fails to build-up steam to 14 pounds pressure.	
<ol style="list-style-type: none"> 1. Steam trap fails to operate properly. 2. Exhaust valve fails to hold pressure at 14 pounds. 3. Steam leaks around door. 4. Safety valve blows off below 15 pounds pressure. 5. Element control switch not properly adjusted. 	<ol style="list-style-type: none"> 1. Replace the steam trap. 2. Check for correct adjustment or strip down, clean and repair. 3. Clean seating surfaces and gasket to make sure they are free of food particles. Check for worm gasket or make door adjustment. 4. Replace safety valve. 5. Readjust.
C. Unit releases pressure before cooking cycle has terminated on timer.	
<ol style="list-style-type: none"> 1. Power loss. 2. Low water cut-off has functioned prematurely. 	<ol style="list-style-type: none"> 1. Check for disruption at source of electric supply. 2. Adjust or replace low water cut-off.
D. Timer does not function at 10 PSI of cylinder pressure to start countdown.	
<ol style="list-style-type: none"> 1. Loose or broken electrical leads to the timer or timer control switch. 2. Timer motor defective. 3. Timer control switch defective or out of adjustment. 	<ol style="list-style-type: none"> 1. Repair or replace defective wiring. 2. Check timer motor for continuity. Replace complete timer if found defective. 3. Make continuity check, adjust, replace is needed.
E. Uneven cooking.	
<ol style="list-style-type: none"> 1. Steam trap closing prematurely, preventing removal of air from the cooking chamber. 	<ol style="list-style-type: none"> 1. Replace the steam trap.
F. Heating elements cutting out before 13 pounds pressure is reached.	
<ol style="list-style-type: none"> 1. Pressure cutting off electric at the element control switch too soon. 	<ol style="list-style-type: none"> 1. Make adjustments on the dial of the element control switch to remedy.
G. Indicator light fails to light with 60 minute timer set.	
<ol style="list-style-type: none"> 1. Power to unit off. 2. Indicator light burned out. 3. Faulty wiring. 4. 60 minute timer contact faulty. 	<ol style="list-style-type: none"> 1. Locate external circuit breaker for incoming power and place in on position. 2. Replace light. 3. Inspect wiring, replace if needed. 4. Replace 60 minute timer.
H. Excessive steam pressure in compartment above 15 pounds.	
<ol style="list-style-type: none"> 1. Safety valve fails in closed position. 2. Pressure switch contacts fail to closed position. 	<ol style="list-style-type: none"> 1. Replace valve. 2. Replace switch.
I. Buzzer fails to sound at end of cooking cycle.	
<ol style="list-style-type: none"> 1. Faulty wiring. 2. Faulty buzzer. 3. Faulty timer. 	<ol style="list-style-type: none"> 1. Check wiring from buzzer to terminal block and timer. 2. Replace buzzer. 3. Replace timer.