



MARKET FORGE

IMPORTANT FOR FUTURE REFERENCE

Please complete this information and retain this manual for the life of the equipment:

Model #: _____

Serial #: _____

Date Purchased: _____

PARTS LIST & SERVICE MANUAL

A cXi `Uf`6 UgY`9`YWf]WH]`h]b[`? YthYg`

AH!&) 9C`AH!(\$9C

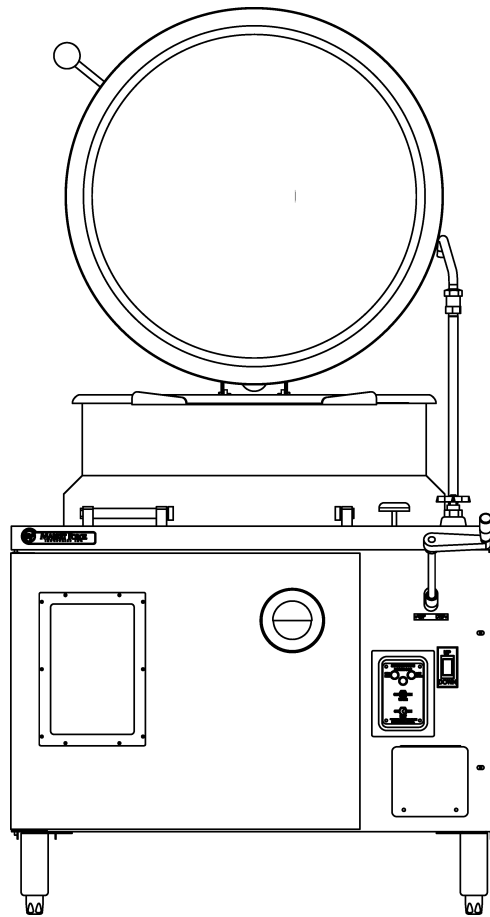

WARNING

Improper installation, adjustment, alteration, service or maintenance can cause property damage, injury or death. Read the installation, operating and maintenance instructions thoroughly before installing or servicing this equipment.

CROWN FOOD SERVICE EQUIPMENT

 A Middleby Company

70 Oakdale Road, Downsview (Toronto) Ontario, Canada, M3N 1V9

Telephone: 919-762-1000

www.crownsteamgroup.com

Printed in Canada



TABLE OF CONTENTS

GENERAL TROUBLESHOOTING	3
PRESSURE CONTROL SWITCH ADJUSTMENT	5
COLD WATER CONDENSER & LID COUNTERBALANCE ADJUSTMENT	6
HEATING ELEMENT REPLACEMENT	7
WATER CONTROL BOARD TESTING PROCEDURE	8
WATER LEVEL CONTROL ADJUSTMENT	10
DRAW-OFF VALVE REPAIR	11
TILTING MECHANISM REPAIR	12
WIRING DIAGRAM.....	13
SCHEMATIC.....	14
ILLUSTRATED PART LIST	
PRESSURE SWITCHES.....	15
DRAIN ASSEMBLY.....	16
TILTING MECHANISM.....	17
PISTON ASSEMBLY	18
VALVE AND FAUCET.....	19
LOW WATER CUTOFF	20
CRANK SHAFT	21
BOILER BASE ASSEMBLY	22
ELECTRICAL COMPONENTS	23
VALVE ASSEMBLY.....	24
KETTLE JACKET ASSEMBLY.....	25

GENERAL TROUBLESHOOTING

TROUBLE	POSSIBLE CAUSE	REMEDY
POWER ON/OFF SWITCH FAILS TO LIGHT WITH SWITCH IN ON POSITION.	Power to kettle off.	Located external Shut-Off (circuit breaker) for incoming power and place in ON position.
	Low water level in kettle reservoir	Fill reservoir.
	Power ON/OFF light burned out	Replace switch.
	Faulty power ON/OFF switch	Replace switch.
	Faulty water level control	Replace control (see water level control)
	Faulty wiring.	Inspect condition of wire & tightness of all connectors. Correct as required.
KETTLE NOT HOT ENOUGH TO BOIL WATER.	Air in kettle reservoir.	Replace steam trap as needed.
	Faulty (weeping) safety relief valve.	Replace valve.
	Burned out heating elements.	Replace as required (see heating element replacement).
	Pressure switch faulty.	Recalibrate or replace as required (see adjustments).
LOW WATER LIGHT ON.	Low water level in reservoir.	Fill reservoir.
	Faulty wiring.	Inspect and repair as required.
	Defective water level control.	Replace control as required.
	Lime build-up on probes.	Clean probes (see probe cleaning)
KETTLE HARD TO TILT.	Bearing loose or lacking lubrication.	Repair or replace as required.
WATER DOES NOT ENTER BOILER.	Water main shut-off.	Turn ON.
	Power not reaching unit.	Check main breaker.
	Lack of water level probe sensitivity due to lime build-up.	Clean probe (see water level control maintenance and cleaning).
	Defective water fill valve.	Clean strainer. Check oil for continuity. Replace if defective.
	Defective water switch (marked power switch on control box).	Check continuity. Replace if defective.
	Water pressure to low.	Increase water pressure to 25-50 PSI.
BOILER OVER FILLS WITH WATER.	Lack of water level probe sensitivity due to lime build-up.	Clean probe (see probe cleaning)
	Water fill valve fails to close.	Clean valve seat and strainer.
	Defective water level board.	Replace.
	Water pressure to high.	Check pressure. If above 50 PSI, decrease pressure.
WATER ENTERS BOILER VERY SLOWLY.	Dirty strainer screen in water fill valve.	Clean or replace strainer screen.
	Dirt or lime accumulation of water fill valve seat.	Clean valve seat.
	Water pressure to low	Increase pressure to 25-50 PSI.
AIRVENT LEAKING.	Not closing.	Replace.

GENERAL TROUBLESHOOTING

TROUBLE	POSSIBLE CAUSE	REMEDY
BOILER FAILS TO BUILD UP PRESSURE WHEN WATER LEVEL IS PROPER & HEAT SWITCH IS TURNED ON.	Contactors not pulling in.	Check continuity of coil. If open replace contactor.
	Defective steam trap.	Replace trap or clean.
	Heating elements defective.	Replace if continuity check through the circuitry of each element shows deficiency (see heating element replacement)
BOILER FAILS TO REACH FULL OPERATING PRESSURE (OF APPROX. 15 PSI).	Pressure gauge reads inaccurately.	Replace pressure gauge.
	Operating pressure control and high limit control switches out of adjustment.	Operating pressure control & high limit control switches b. Readjust or replace as required (see pressure switch adjustment)
	Safety valve not seating properly.	Clean or replace as required.
	Contactor coils (1 or both) not energizing and closing circuits to the heating elements.	<ol style="list-style-type: none"> 1. Check contactor. Replace either contactor coils or complete contactor as required. 2. Measure amperage at terminal block. Check to ensure that there is an even draw on all 3 Phases. See wiring diagram for correct amperage draw. If uneven or '0' amp draw is found on 1 of the 3 phases, check for blown fuse. If fuse not blown, shut off power. 3. Remove wires from heating elements & run continuity check. Replace as required.
CONTACTOR CHATTERS.	Incorrect supply voltage.	Check to see that voltage supply matches with coil in connectors.
	Dirty or worn contactor points.	Clean or replace contactor.
	Weak coil.	Replace with correct voltage coil.
SAFETY VALVE BLOWS OFF PREMATURELY.	Pressure set to high.	Readjust pressure switch.
	Pressure gauge reads incorrectly.	Replace pressure gauge.
	Lime or dirt on valve seat.	Clean valve seat.
	Weak spring in valve.	Replace valve.
BOILER BUILDS UP TO PRESSURE, THEN SHUTS DOWN & FAILS TO COME BACK ON.	High limit switch set to low or operating pressure control switch to high.	Readjust or replace as required (see pressure switch adjustment)
COLD WATER CONDENSER DOES NOT FUNCTION.	Main water line shut-off.	Turn on.
	Thermostat out of adjustment or defective.	Readjust for proper operation or replace if defective (see cold water condenser)
	Loose fit.	Tighten coil as close to body of valve as possible.
	Coil not continuous.	If open, replace.
CONTACTOR CHATTER.	a..... Low voltage.	<ol style="list-style-type: none"> 1. Check voltage condition. Check momentary voltage dip during starting. Low voltage prevents magnet sealing. 2. Check coil voltage rating. Correct voltage condition as required.
	Defective or incorrect coil.	Replace coil. Rating of coil must match the line voltage

PRESSURE CONTROL SWITCH ADJUSTMENT

If boiler fails to maintain steam pressure in operating range, pressure control switch may require adjustment.

1. Start boiler and allow pressure to build up to operating level - 15 PSI (1kg/cm²).
2. Check boiler pressure gauge. If gauge indicates 12 to 14 PSI, pressure control switches are properly adjusted.
3. If boiler does not come on when pressure gauge reads 7 PSI and does not go off when pressure gauge reads 14 PSI, proceed as follows:

WARNING

Because power must be on to adjust pressure switches, be sure to protect against electrical shock.

- a. Remove screw and lift front cover off control box.
- b. Hand adjust operating pressure control switch and high limit pressure control switch by turning adjusting nut (Knurled knob) clockwise to raise and counter clockwise to lower actuation point. Switch should be set so that boiler comes on when boiler pressure gauge reads 12 PSI and goes off when gauge reads 14 PSI. Switch should be set so that boiler will shut off if pressure reaches 15 PSI.
- c. The actuation value (differential) is factory set and cannot be changed.
- d. Repeat steps, 1, 2, and 3. If 45 to 14 PSI boiler pressure gauge reading is obtained during boiler operation, adjustment is correct. If proper adjustment cannot be made consult Trouble-Shooting Guide in this manual.
- e. After making adjustments, replace cover on pressure switch box and screw.

WARNING

Because power must be on to adjust pressure switches, be sure to protect against electrical shock.

1. Check that the (2) different switches are actually used.
2. Set high limit switch H15 all the way to maximum at 15 PSI.
3. Set operating control switch F15 ON at 10 PSI, OFF at 12 PSI.

When unit is properly operating, switch F15 will shut boiler off at approximately 14 PSI and turn back on at approximately 11 PSI.

Also, switch H15 will cause low water light on boiler control box (under cabinet) to come on due to reaching high pressure.

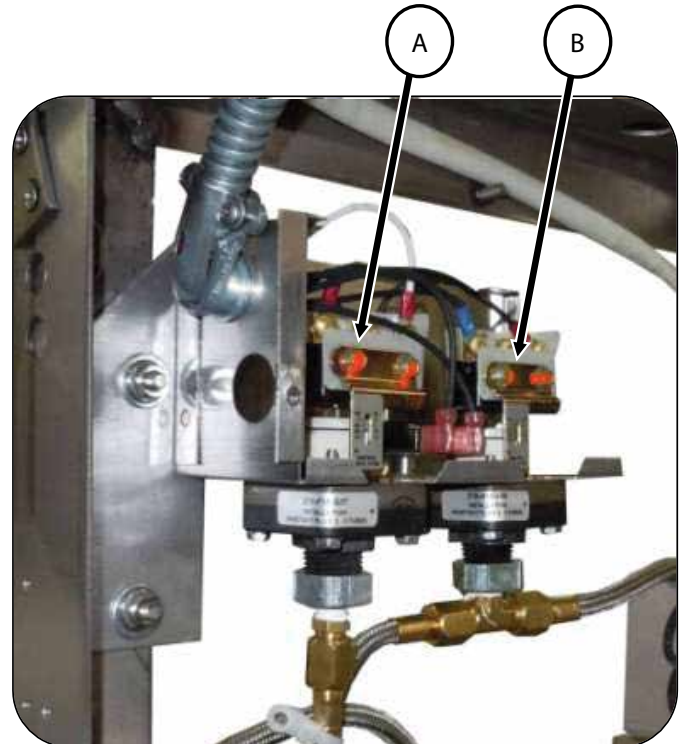

COLD WATER CONDENSER & LID COUNTERBALANCE ADJUSTMENT

COLD WATER CONDENSER ADJUSTMENT

The function of the cold water condenser is to keep the temperature in the drain line from exceeding 150°F (66°C). Solenoid valve (see Figure 4) controls the water flow to the cold water condenser. The valve opens and runs cold water through the drain until the temperature drops below 150°F (66°C). The water flow may be regulated by adjusting thermostat dial.

The valve has a built-in water strainer which should be removed and periodically cleaned.

LID COUNTERBALANCE ADJUSTMENT

The kettle lid is equipped with a torsion spring counterbalance device to assist in lid lifting and to prevent slamming. The device is shown assembled in figure 5 (internal cabinet, side view) and exploded in figure 0 (hinge and lid assembly). If lid slams closed when handle is released, spring tension should be increased. If lid lifts up or refuses to remain down on kettle, tension should be reduced. To adjust spring tension, proceed as follows:

1. Lift cover to open position.
2. Pull down on piston assembly to release it from its position. Rotate "T" bar clockwise to increase tension, continue clockwise to reduce tension.
3. Operate lid several times. Repeat step 2 until desired operation is obtained.
4. Hold hex head screw firmly in position and tighten hex nut to lock adjustment.



HEATING ELEMENT REPLACEMENT

Check for defective heating elements as follows:

With the power off and disconnected, connect an ohm-meter to the two leads of each element loop at room temperature. Resistance should be as follows:

VOLTS	OHMS
208	10.8 +/- 5%
240	14.4 +/- 5%
*480	38.0 +/- 5%

*480 OHM rating is based on 4000 w/277v.

If not, element is defective and must be replaced. Proceed as follows:

1. Shut down power to unit, boiler will drain.
2. Disconnect wires at contactor.
3. Remove nut (2) and gasket until element is freed.
4. Replace with new element.

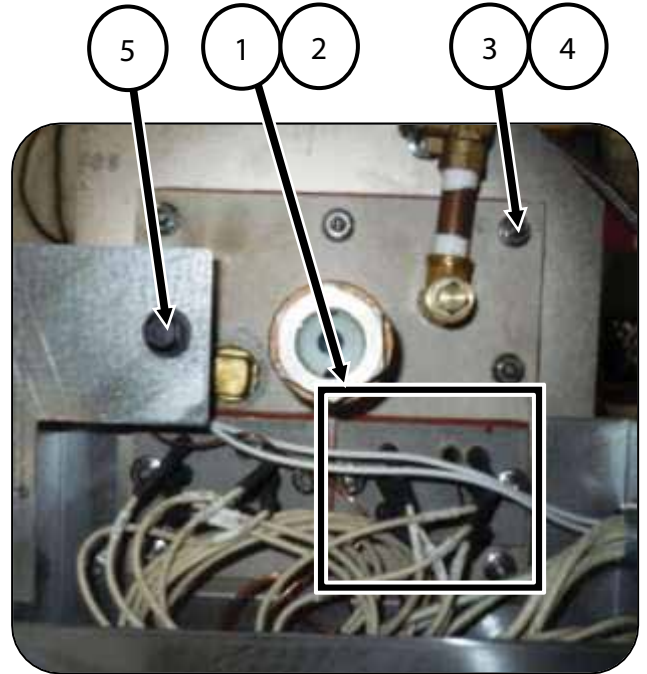

ITEM	PART NO.	DESCRIPTION
1	08-6415	208V Element, 12 kW
1	08-6416	240V Element, 12 kW
1	08-6417	480V Element, 12 kW
2	91-8660	Element Gasket
3	98-3945	Nut
4	91-8756	Gasket Front Plate
5	08-6553	Secondary Low Water Cut Off

WATER CONTROL BOARD TESTING PROCEDURE

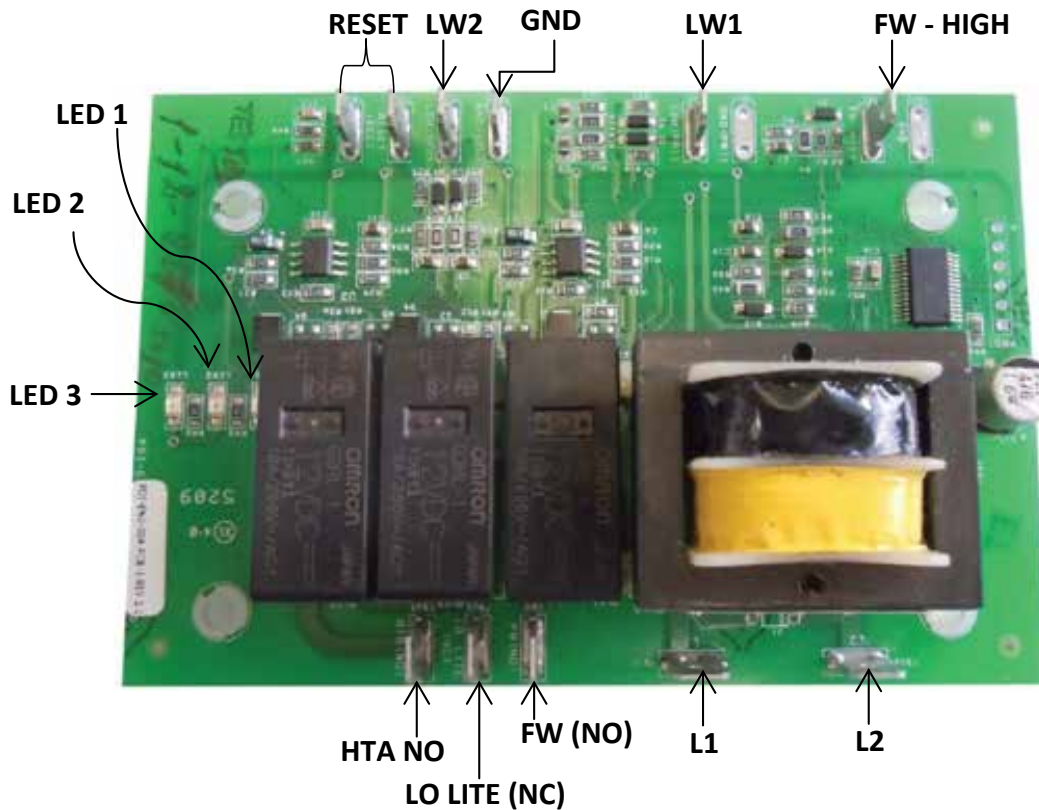

This test procedure is to be used to determine if the control is working properly. It is not intended to determine why the control may have failed.

If testing shows that the control is operating properly, check all probe and solenoid wiring and the condition of the electrodes in the steam chamber.

Contact the factory if the boiler still does not operate properly after completing the testing.

Tools Needed:

- Digital or Analog V-O-M meter.
- Alligator clip type test jumpers (2 sets min.).

Turn Off Power to Control:

- Use V-O-M to verify there is no power at terminals L 1 & L2.
- Use V-O-M to verify that there is no power at terminals 'FW(NO)', 'LO LITE(NC)' & 'HTR(NO)'. If there is power at any of these terminals, you will need to find the source and turn it off.

Remove Wires from Probe and Relay Switch Terminals:

- DO NOT remove wires from L 1 & L2 terminals.
- Tag wires and remove from probe and relay contact terminals including 'GND' terminal.

- Tag and remove wires from 'RESET' terminals.
- Connect jumper wire to both 'RESET' terminals.

Turn Power On to Terminals L 1 & L2:

- 'LED 1' should turn on.
- 'LED 2' should be off.
- 'LED 3' should be off.
- Use V-O-M to verify that there is power at 'FW(NO)' & 'LO LITE(NC)' terminals and no power 'HTR(NO)' terminals

Test Feedwater Function:

- Connect jumper wire to 'FW HIGH and 'GND' terminals.
- 'LED 1' should turn off after a 10 second delay.
- Use V-O-M to verify that there is no power at the 'FW (NO)' terminal.
- Remove jumper from 'FW HIGH' and 'GND' terminals. . 'LED 1' should turn on.
- Use V-O-M to verify that there is power at the 'FW(NO)' terminal.

WATER CONTROL BOARD TESTING PROCEDURE

Test Primary Low Water Function:

- Connect jumper wire to 'LW(1)' and 'GND' terminals.
- 'LED 2' should turn on.
- Remove jumper wire from 'LW(1)' and 'GND' terminals.
- 'LED 2' should turn off after a 3 second delay.
- Connect jumper wire to 'LW(1)' and 'GND' terminals.
- 'LED 2' should turn on.



IMPORTANT

Jumper wire between 'LW(1)' and 'GND' terminals must remain in place to test secondary low water function.

Test Secondary Low Water Function:

- Connect jumper wire to 'LW(2)' and 'GND' terminals.
- 'LED 3' should remain off.
- Use V-O-M to verify that there is power at the 'LO LITE(NC)' terminal and no power at the 'HTR(NO)' terminal.
- Remove the jumper wires from the 'RESET' terminals.

- 'LED 3' should turn on.
- Use V-O-M to verify that there is no power at the 'LO LITE(NC)' terminal and power at the 'HTR(NO)' terminal.
- Connect jumper wire to 'RESET' terminals.
- Remove jumper wire from 'LW(2)' and 'GND' terminals.
- 'LED 3' should turn off after a 3 second delay.
- USE V-O-M to verify that there is power at the 'LO LITE(NC)' terminal and no power at the 'HTR(NO)' terminal.
- Connect jumper wire from 'LW(2)' and 'GND' terminals.
- 'LED 3' should remain off.

IF ANY OF THE FUNCTIONS DO NOT WORK, REPLACE THE BOARD!

IF ALL FUNCTIONS WORK, TROUBLE-SHOOTING OTHER COMPONENTS WILL BE REQUIRED!

WATER LEVEL CONTROL ADJUSTMENT

Circuit Operation

Boiler water level is controlled by rising and falling water level which makes and breaks circuits between two different length probe electrodes inside boiler and the grounded boiler wall.

The short probe is used to turn water on and off as required. The long probe is used to cut off power to the heating elements and give a signal alarm when water is too low.

A secondary low water cut-off is used as a warning device to dry firing and serves as a warning device to delime/descale boiler.

Water Level Control Operation

Starting with an empty boiler, switch S1 is closed to start the following sequence.

1. Solenoid R-1 energizes allowing water to flow into boiler. At the same time, the primary circuit of T-1 is energized.
2. Boiler continues to fill until water level reaches tip of electrode probe A completing the secondary circuit of T-1 and energizing C-3.
3. When C-3 is energized, NC (normally closed) contact opens which de-energizes R-1 and stops water flow. NO (normally open) contact closes completing circuit to probe B.

As water boils away below the end of probe B, the following occurs:

1. Secondary circuit of T-1 is broken and C-3 de-energizes.
2. When C-3 de-energizes, NO contact opens to break circuit to probe A while NC contact closes which energizes R-1 and allows boiler to fill.

Low Water Cut-Off

When S-1 is closed, the following also occurs:

1. Primary circuit of T-2 is energized.
2. When water level reaches probe C and S-2 is momentarily closed, C-4 is energized.
3. When C-4 is energized, NO contacts close completing low water cut-off circuit through contacts 7 and 8 and completing circuit through contacts 3 and 4 energizing C-1 and C-2 which closes heater circuit.

If water drops below probe C, the following occurs:

1. Secondary circuit of T-2 breaks and C-4 de-energizes. Contact 7 and 8 and 3 and 4 open to break circuit to C-1 which opens circuit to heating elements.

C-1 and C-2 will not operate until water level in boiler is normal and S-2 is momentarily closed.

Water Level Control Maintenance & Cleaning

The water level is controlled by two probes mounted on the top of the boiler or on front of the boiler. Inspection should be done at least two times a year as determined by local water conditions. Probe electrodes must be as free of scale and sludge build-up as possible to insure proper functioning of water level control system.

Electrode lengths must be checked to insure proper water level settings.

If probe electrodes and housing appear to have little or no build-up of scale or sludge, use Market Forge Total Concept Chemical Cleaner Descaler (p/n 20-0307) for this minor cleaning. This type of cleaning should be done at least twice a year (refer to page 25 for complete Total Concept Application Instructions)

Probe Cleaning

The following procedure should be followed for cleaning probes when build-up is considerable (at least once a year):

1. Clean both probes, in detergent and water using a nylon brush for scrubbing. Rinse thoroughly in clear water. If scale and sludge build-up has been removed, and reinstall. If probes are not clean, proceed to step #2 and #3.
2. Use emery cloth or sandpaper to remove scale from probes. Rinse thoroughly in clear water.
3. A U.S.D.A. approved boiler cleaner may be used for more thorough cleaning of probes.

DRAW-OFF VALVE REPAIR

Common Leak Repairs

To repair a valve leak, the source must first be determined. Leaks from around the valve stem are corrected by replacing the rubber "O" ring. Dripping from the valve outlet which occurs with the valve tightly closed indicates faulty seating of the valve disc (part of 6) against the valve seat. Dripping is often corrected by cleaning residue from disc and seat using very fine emery.

Valve Seat Lapping

If either the disc (part of 6) or seat is found damaged, it is necessary to either replace the entire valve or perform the lapping procedure as follows:

1. Disassemble valve and clean both disc and valve seat.
2. Attach handle (2) to stem with valve bonnet (4) removed.
3. Apply a good grade of fine lapping compound to disc and inset it into valve to make light contact against seat.
4. Rotate stem disc against seat by turning handle. This rotation allows stem to wobble in space the bonnet would normally occupy. Continue with light pressure until compound dries.
5. Reassemble and test for leaks with valve closed. If dripping occurs, repeat lapping procedure as many times as required to obtain a water-tight seal.

TILTING MECHANISM REPAIR

MT40EO tilting kettles are equipped with tilting mechanisms.

Lift Screw Assembly Removal

The assembly is removed with the kettle in the lowered position. Assembly removal proceeds as follows:

1. Remove the two bolts which hold ball nut assembly in screw lever (7).
2. Remove the two 5/16" hex head cap screws which fasten the screw housing to cabinet frame.
3. Lift screw assembly from cabinet.

NOTE: Proceed in reverse order to replace the assembly.

General Inspection & Cleaning

The screw assembly should run smoothly throughout the entire stroke. If operation is not uniform, remove the screw assembly (see Saginaw screw assembly removal) and proceed as follows:

1. Inspect screw shaft for accumulation of foreign matter in the ball grooves.
2. Using cleaning fluid or solvent, remove dirt from ball grooves. Be sure to flush the ball nut assembly thoroughly.
3. Cycle the ball nut along the screw shaft several times. Then, wipe with a dry, lint less cloth and lubricate immediately.

Lift Screw / Tilting Mechanism

The driving end of the Lift Screw is formed into a slotted sleeve which receives the engagement pins of the removable hand crank.

The Lift Screw assembly must be removed from the kettle to complete installation. The collar is removed by driving out the roll pin which secures it to the screw shaft. The replacement sleeve slides over the faulty shaft end and is fastened with a roll pin. The repair is completed by re-mounting the Saginaw Screw assembly.

Tilting Mechanism Lubrication

Lubrication of the tilting mechanism is the only required preventive maintenance other than daily cleaning. Inspect the screw of the tilting mechanism annually for adequate lubrication. If screw appears "dry", apply good grade bearing grease directly on the threads so that the threads appear to be barely damp. If mechanism fails to run smoothly.

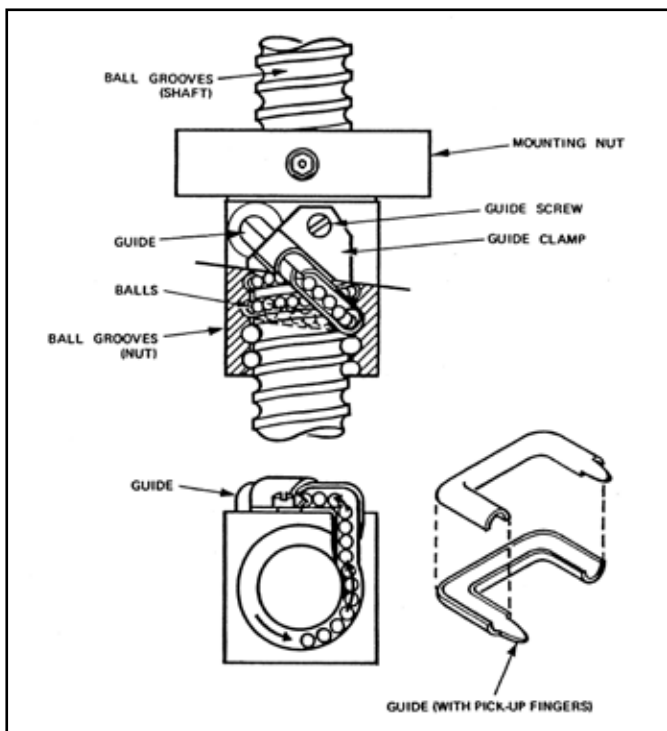

WIRING DIAGRAM

- NOTES:
1. ALL WIRING #16 AWG., 28 STRAND 125°C TYPE 3173, 600V., EXCEPT AS NOTED. MUST BE U.L. & C.S.A. APPROVED.
 2. WIRES #35 THRU #43, #10 AWG., 250°C., TYPE 1A01, 600V., EXCEPT AS NOTED. MUST BE U.L. & C.S.A. APPROVED.
 3. REFER TO WIRE LEAD SCHEDULE 91-8521.
 4. REFER TO WIRE LEAD SCHEDULE 91-9221.

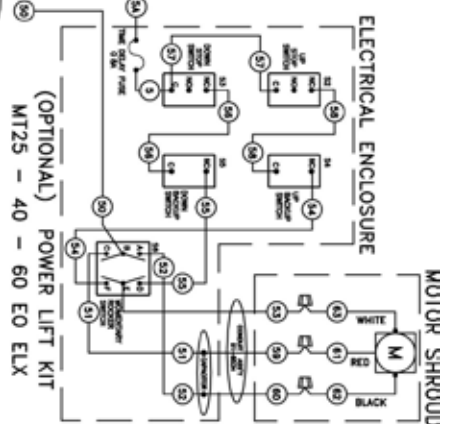
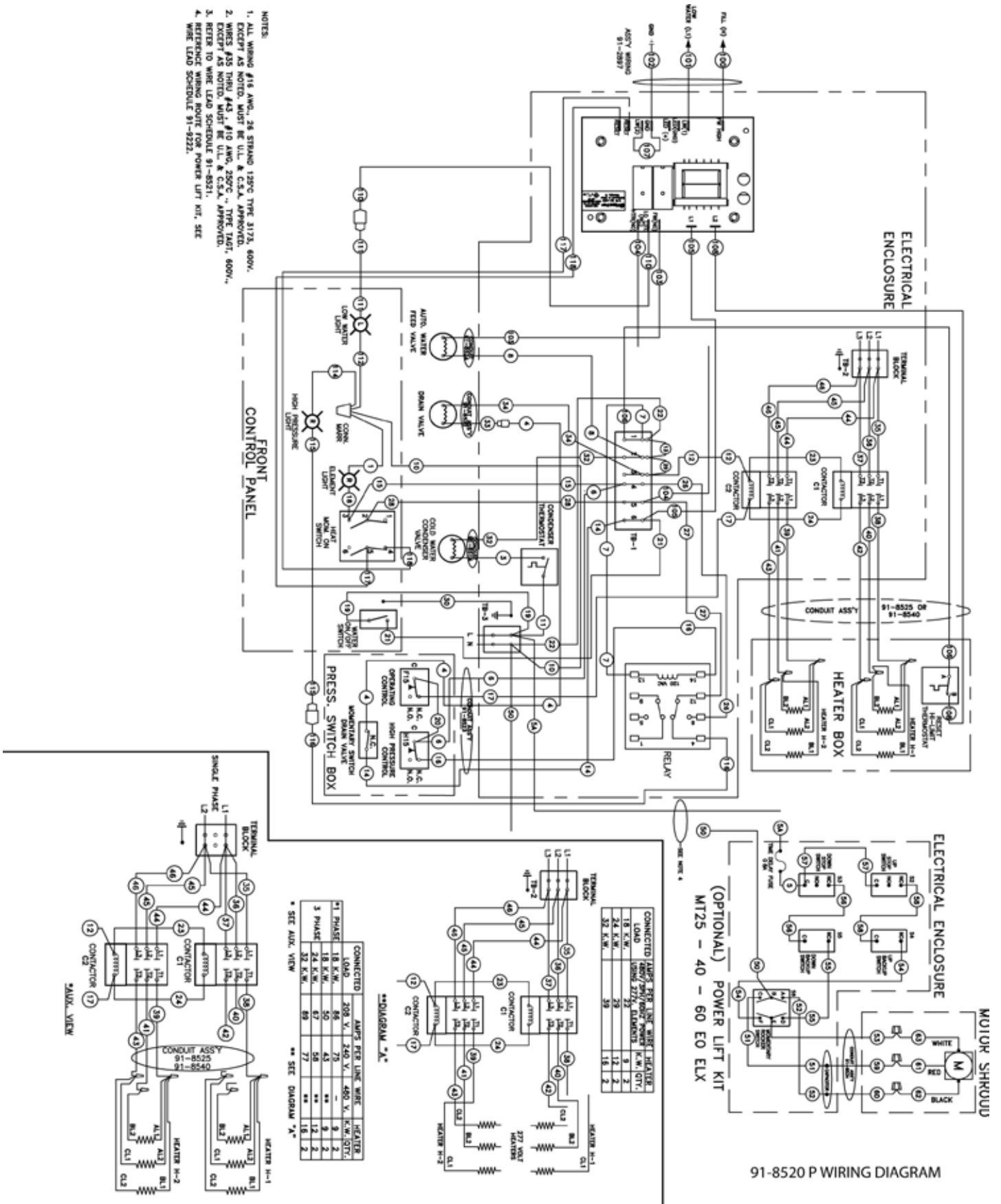

CONNECTED LOAD	HIGHER TEST LINE SIZE	HEATER
18 K.W.	22	HEATER H-1
24 K.W.	22	HEATER H-2
32 K.W.	29	HEATER H-1
		HEATER H-2

****DIAGRAM "A"**

CONNECTED LOAD	AMPS PER LINE WIRE	HEATER
18 K.W.	86	HEATER H-1
24 K.W.	75	HEATER H-2
30 K.W.	50	HEATER H-1
37 K.W.	67	HEATER H-2
45 K.W.	58	HEATER H-1
53 K.W.	77	HEATER H-2
61 K.W.	89	HEATER H-1
70 K.W.	77	HEATER H-2

**** SEE AUX. VIEW**

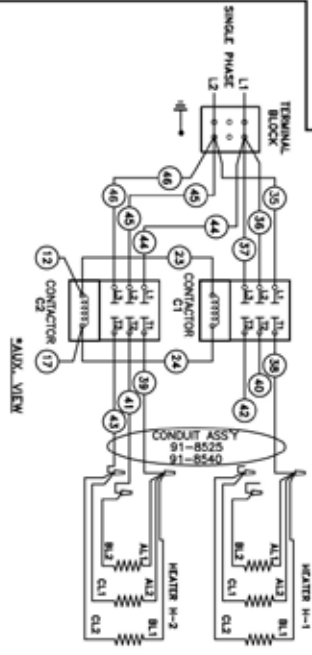

91-8520 P WIRING DIAGRAM

SCHEMATIC

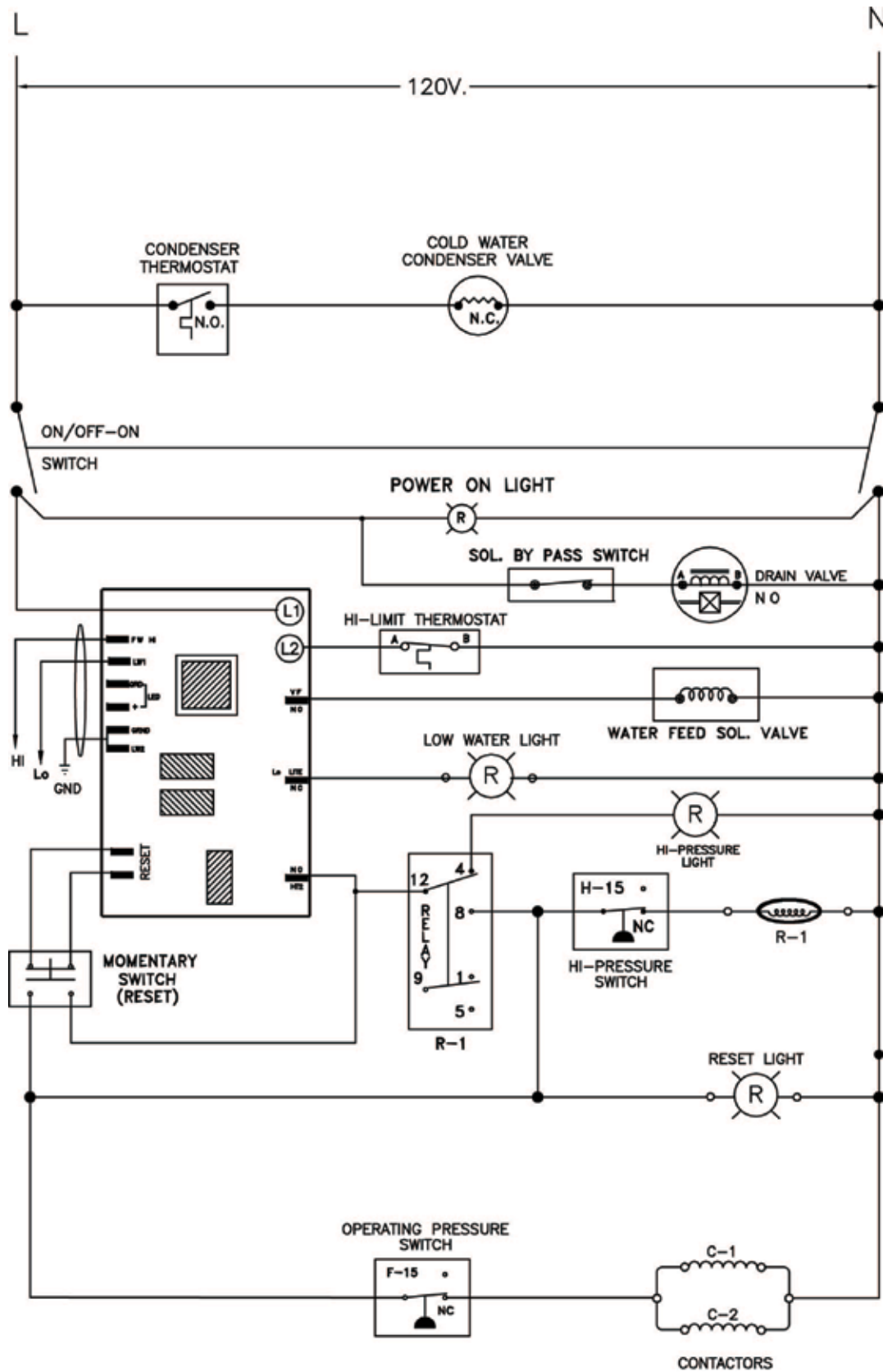

91-8520 P SCHEMATIC, MT25 - 40 & 60 EO

PRESSURE SWITCHES

FRONT AND REAR VIEW

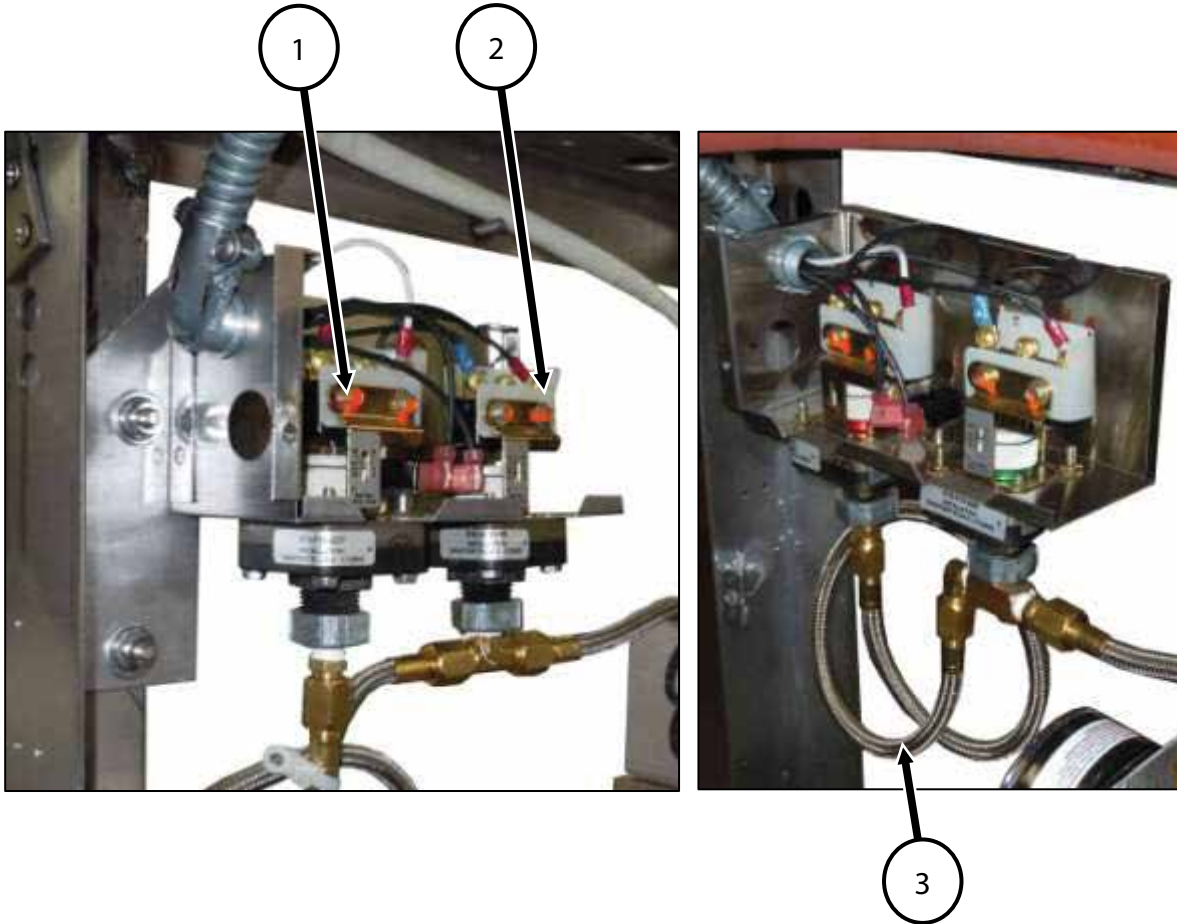

ITEM	PART NO.	DESCRIPTION
1	10-8410	HIGH LIMIT – PRESSURE SWITCH
2	10-8411	OPERATING – PRESSURE SWITCH
3	98-4131	STAINLESS STEEL, BRAID HOSE, 5/16 ID X 22" LONG

DRAIN ASSEMBLY

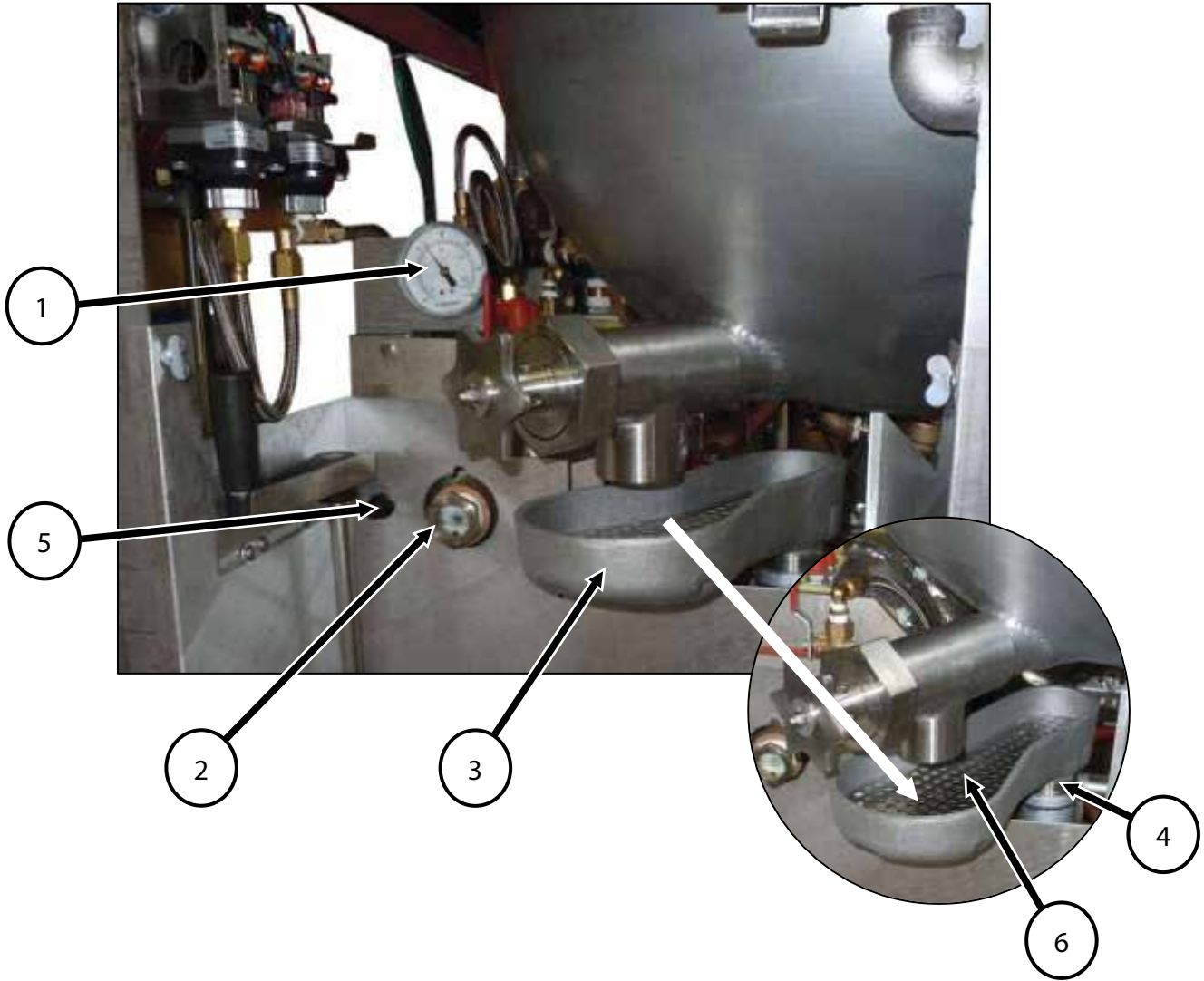

ITEM	PART NO.	DESCRIPTION
1	10-4804	PRESSURE GAUGE
2	10-7974	SIGHT WINDOW
3	10-0412	SWING DRAIN
4	90-7475	SUPPORT, NIPPLE, DRAIN
5	08-6553	LOW WATER CUT OFF
6	91-1835	STRAINER

TILTING MECHANISM

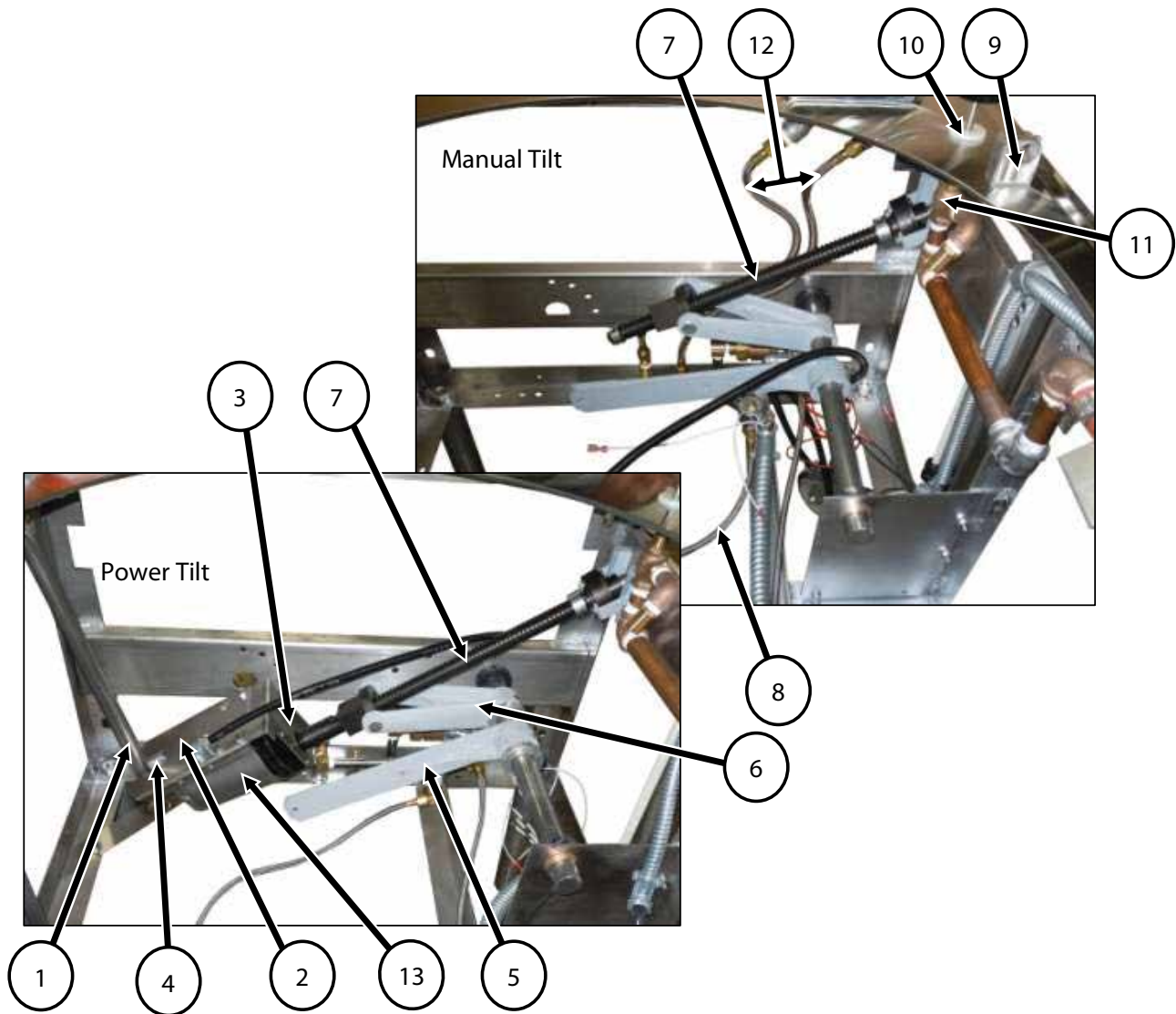

ITEM	PART NO.	DESCRIPTION
1	91-9335	POWER TILT MOTOR WELD ASSEMBLY
2	91-9336	MOTOR MOUNTING PLATE
3	98-1726	POWER LIFT FOOT BRACKET
4	91-9353	POWER TILT NYLON STRIP
5	98-0555	LIFTING LEVER ARM
6	91-9387	LEVER ARM
7	91-9324	LIFT SCREW ASSEMBLY
8	98-4131	CONDENSER HOSE
9	90-3490	HINGE BLOCK
10	08-5217	VALVE RETAINER COLLAR
11	10-5242	VALVE
12	98-4128	FAUCET HOSE
13	98-3696	MOTOR

PISTON ASSEMBLY

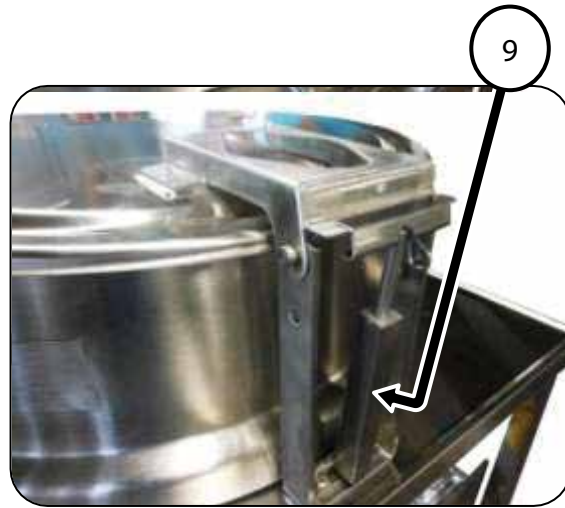
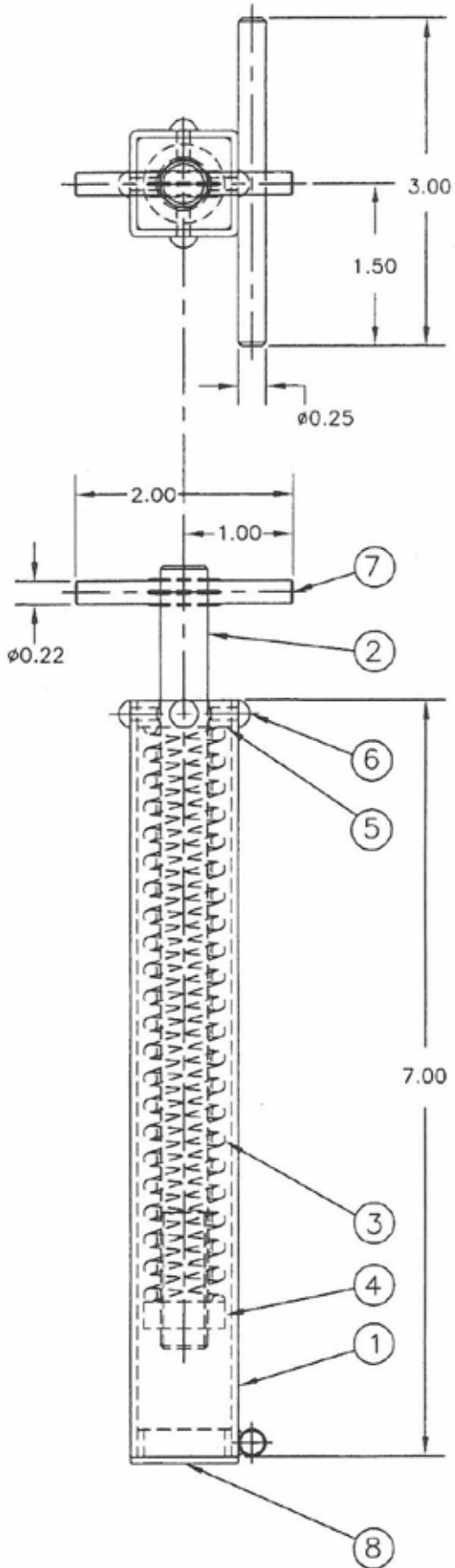

ITEM	PART NO.	DESCRIPTION
1	98-0530	Housing-Compression Rod & Spring
2	98-0535	Compression Rod
3	08-4606	Compression Spring
4	98-0537	Floating Nut
5	98-0536	End Guide
6	08-4200	Rivet, Barbed
7	08-3205	Hooking Pin, Driv Lok Type "E" 7/32 x 2
8	08-1208	Plug, Plastic
9	98-0529	COMPLETE PISTON ASSEMBLY

VALVE AND FAUCET

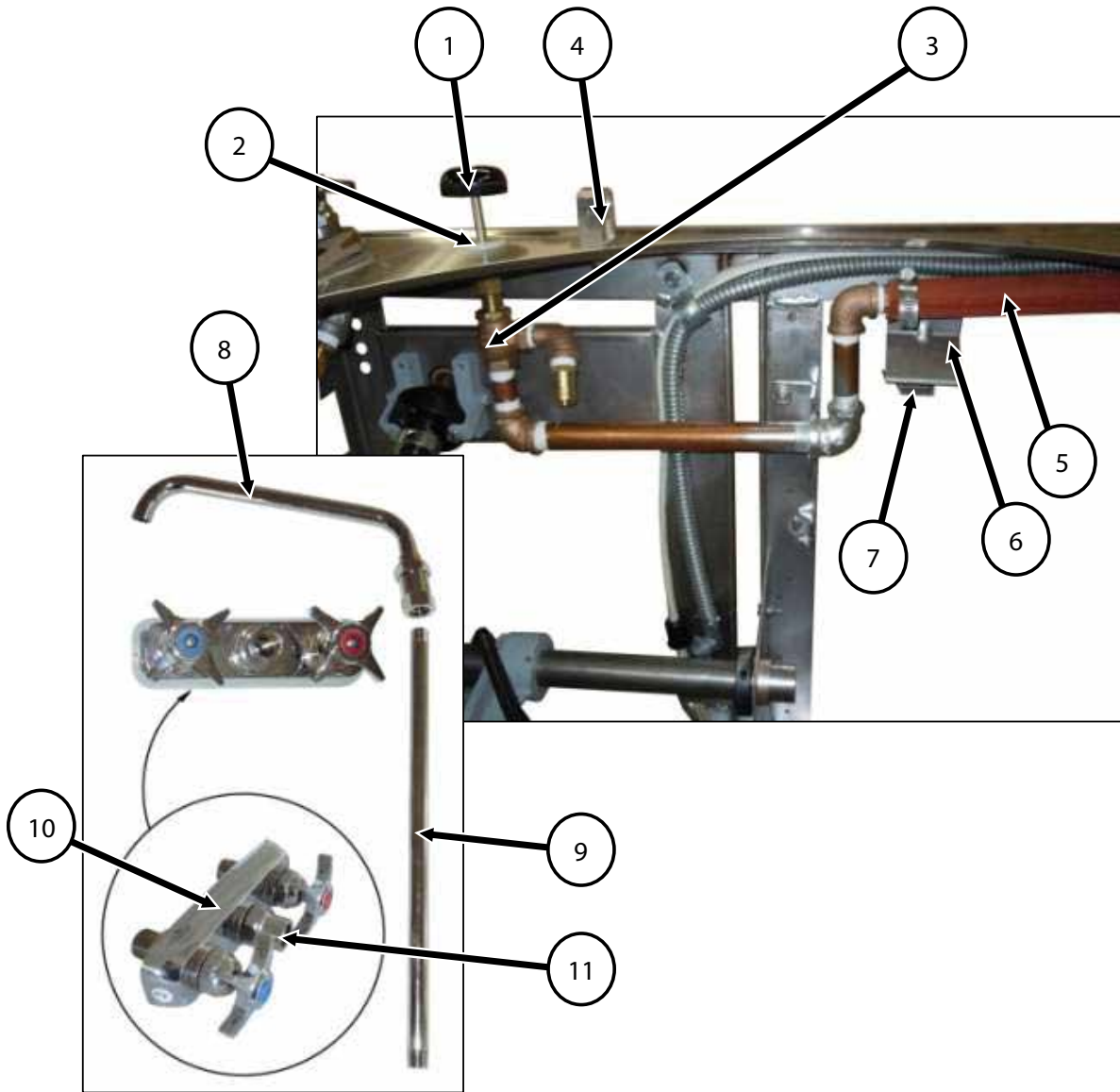

ITEM	PART NO.	DESCRIPTION
1	10-0105A	KNOB
2	10-6303	VALVE RETAINER COLLAR
3	10-5242	VALVE
4	90-3490	HINGE BLOCK
5	91-4795	RUBBER HOSE, 3/4" ID X 36" LONG
6	90-3210	MAGNETIC BRACKET
7	10-5561	DOOR MAGNET
8	10-5753	NOZZLE, SWIVEL SPOUT
9	91-0887	RISER, 15" LONG
10	10-7680	FAUCET SET
11	08-5467	ADAPTER

LOW WATER CUTOFF

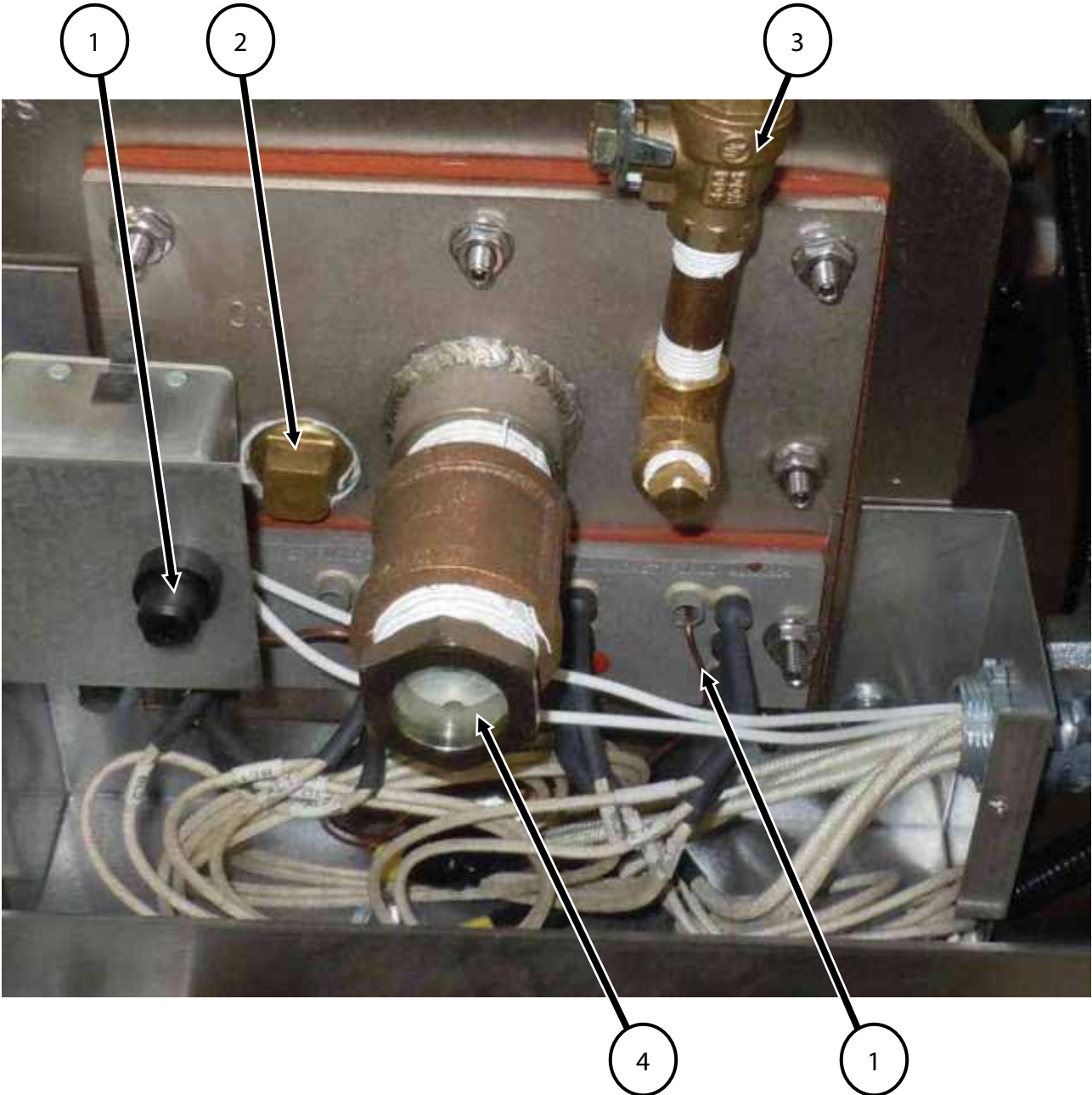

ITEM	PART NO.	DESCRIPTION
1	08-6553	LOW WATER CUT OFF
2	08-0034	ANODE ROD
3	08-4900	BALL VALVE, 1/4"
4	10-7974	SIGHT WINDOW

CRANK SHAFT

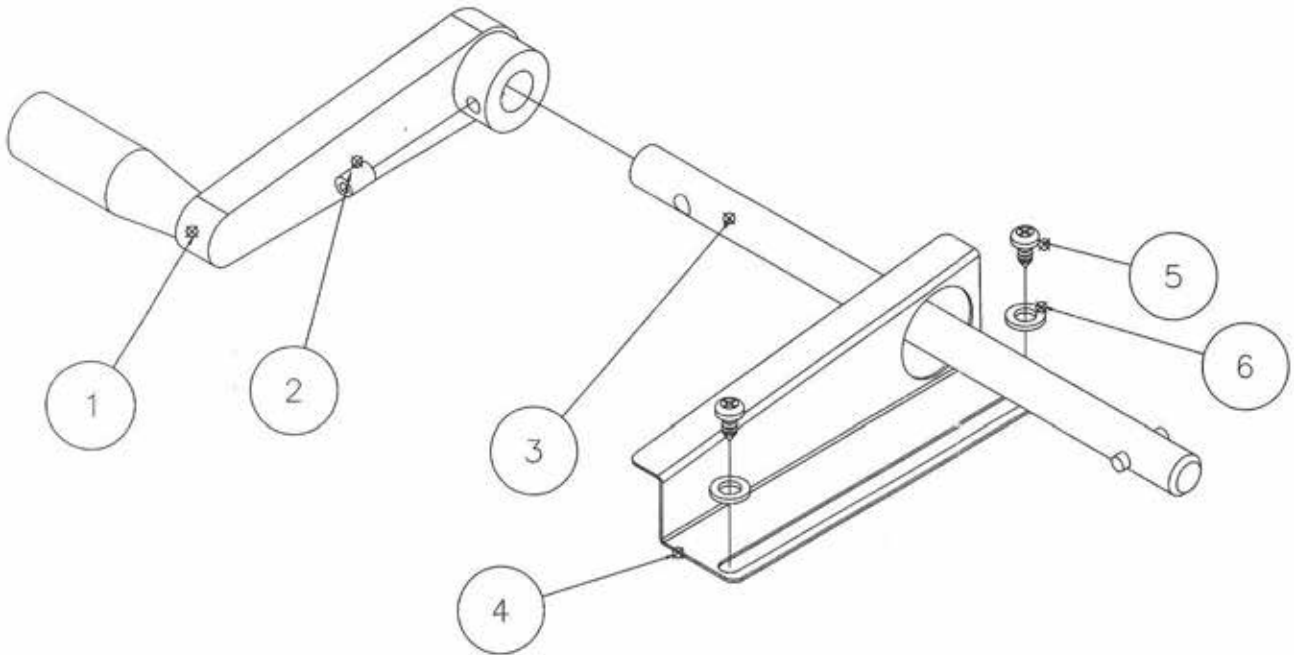

NOTE: 1. BRACKET (ITEM#4) TO BE POSITION AS NEEDED USING EXISTING HOLES IN ALL DOOR PANELS.
2. ITEMS 1-3 TO BE ASSEMBLED AT FACTORY.

ITEM	PART NO.	DESCRIPTION
1	08-7906	Handle with Knob
2	08-7911	Screw, Set 1/4 – 20, 3/8" Long
3	98-1537	Assembly, Crank Shaft
4	90-8878	Clip, Bracket, Universal
5	10-1735	Screw, #8-32, Sheet Metal
6	10-2508	Washer, Stainless Steel

BOILER BASE ASSEMBLY

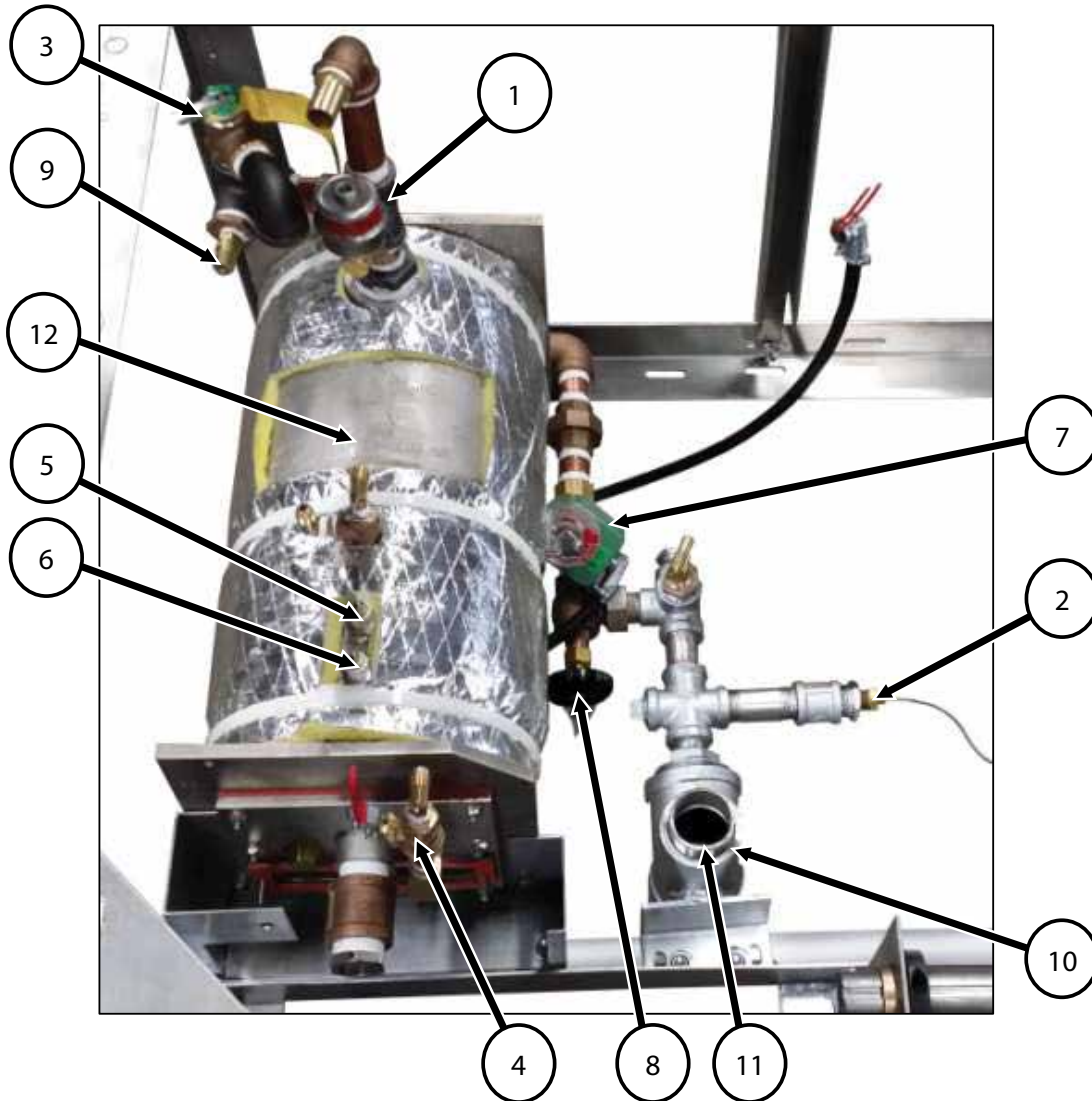

ITEM	PART NO.	DESCRIPTION
1	09-4815	AIR VENT
2	10-4653	CONDENSER THERMOSTAT
3	10-5320	PRESSURE RELIEF VALVE
4	08-4900	1/4" BALL VALVE
5	08-6338	LOW WATER PROBE
6	08-6337	HIGH WATER PROBE
7	10-1311	DRAIN VALVE
8	10-3661	STEAM RADIATOR VALVE
9	08-4874	VACUUM BREAKER VALVE
10	90-1873	DRAIN ASSEMBLY, TEE & BRACKET
11	90-7475	DRAIN SUPPORT, NIPPLE
12	14-0535	BOILER TANK

ELECTRICAL COMPONENTS

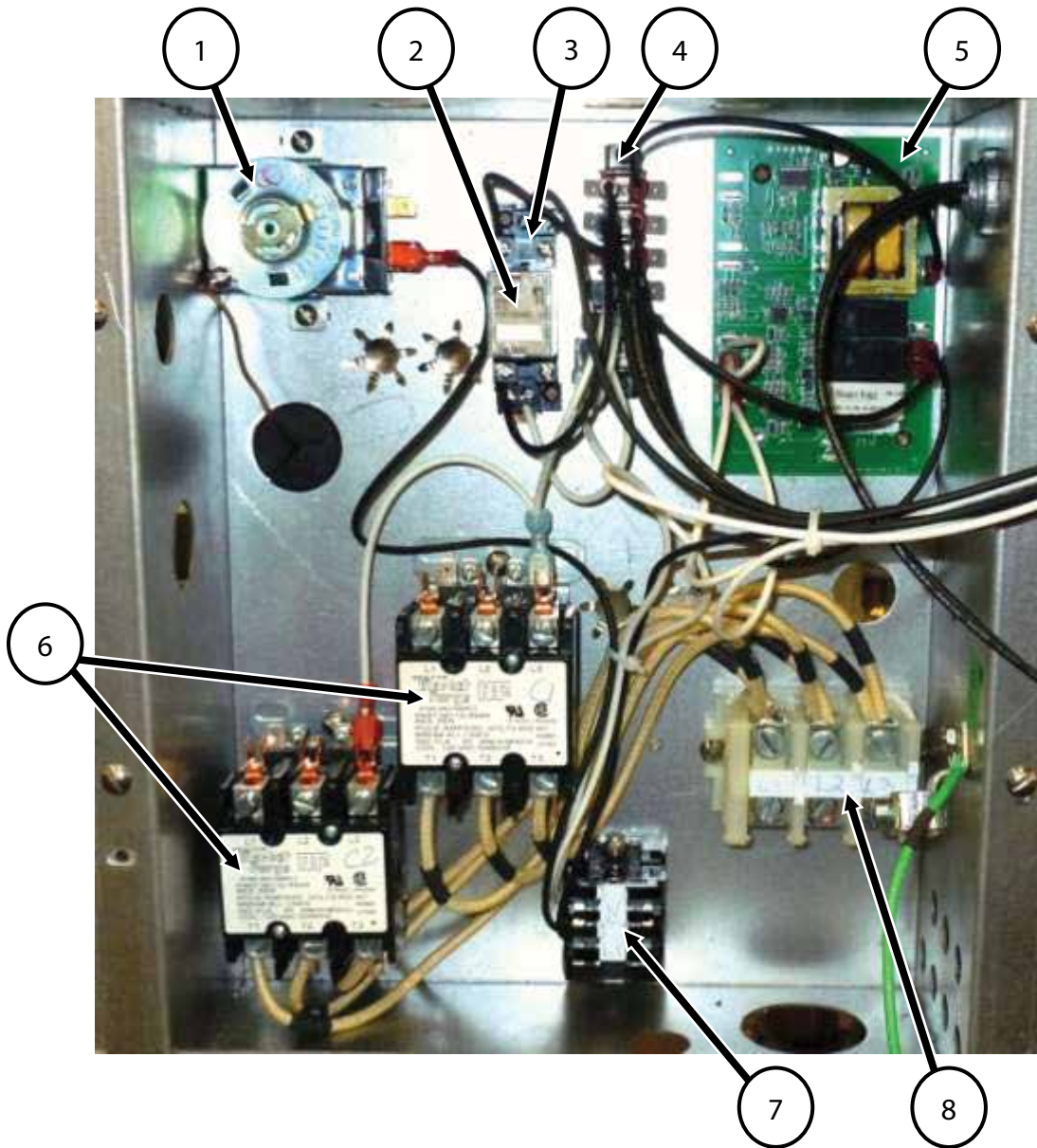

ITEM	PART NO.	DESCRIPTION
1	10-4653	THERMOSTAT
2	08-6472	RELAY
3	08-6475	RELAY SOCKET
4	08-7926	TERMINAL STRIP, TB1
5	98-1680	LIQUID LEVEL CONTROL BOARD, 120V
6	9348-120	CONTACTOR, 40 AMP
7	10-5070	TERMINAL BLOCK, END SECTION
7	10-5503	TERNIMAL BLOCK, CONTACT SECTION
8	97-4616	TERMINAL BLOCK ASSEMBLY, 3 CONTACT
--	10-6859	MICRO SWITCHES (FOR POWER LIFT)
--	08-8017	CAPACITOR, 370 VAC, 50/60 HZ, 7.5 MFD (OPTIONAL)

VALVE ASSEMBLY

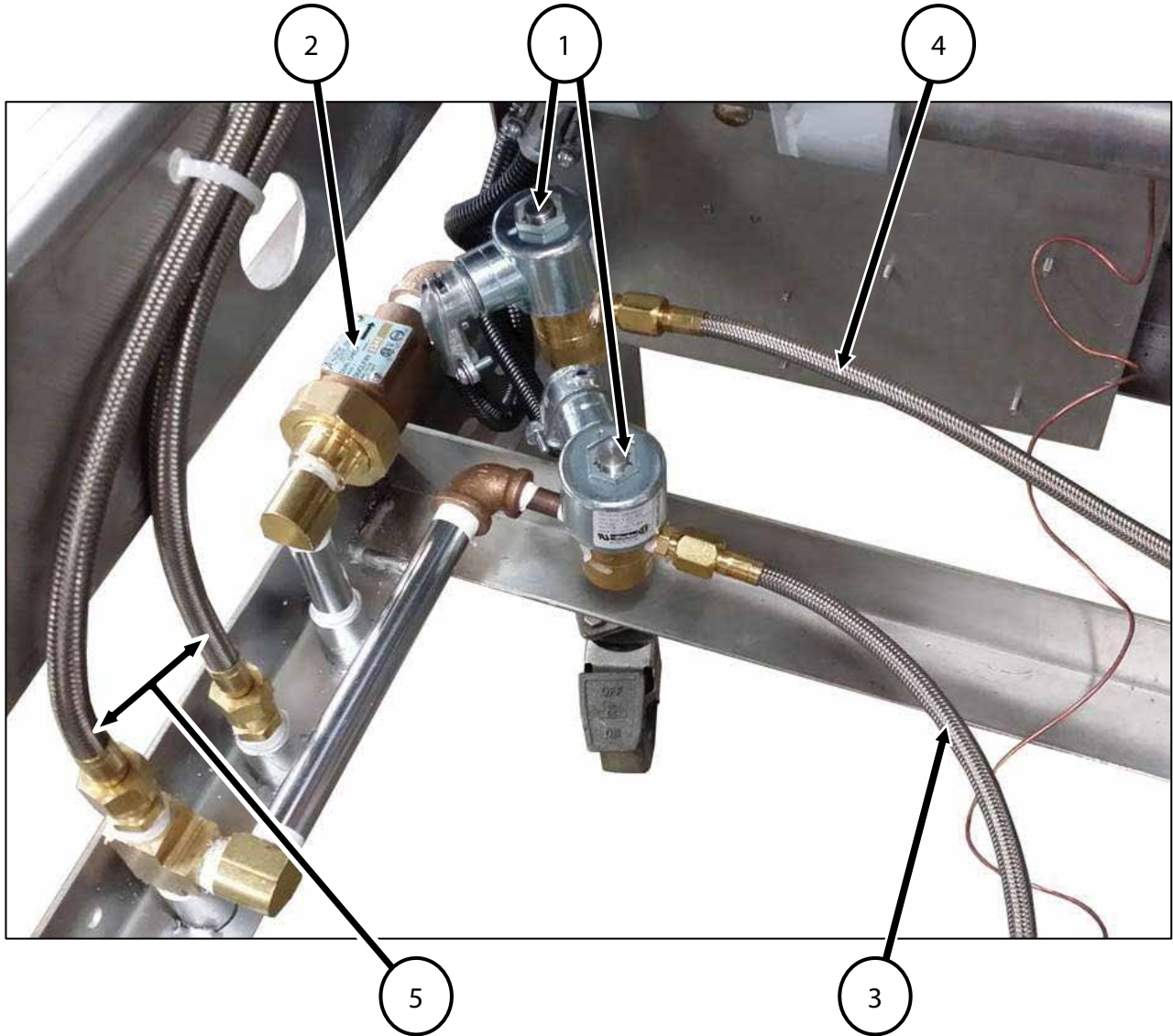

ITEM	PART NO.	DESCRIPTION
1	08-4822	WATER VALVE
2	08-5470	CHECK VALVE
3	98-4131	CONDENSER HOSE
4	98-4130	FILL HOSE
5	98-4128	FAUCET HOSE

KETTLE JACKET ASSEMBLY

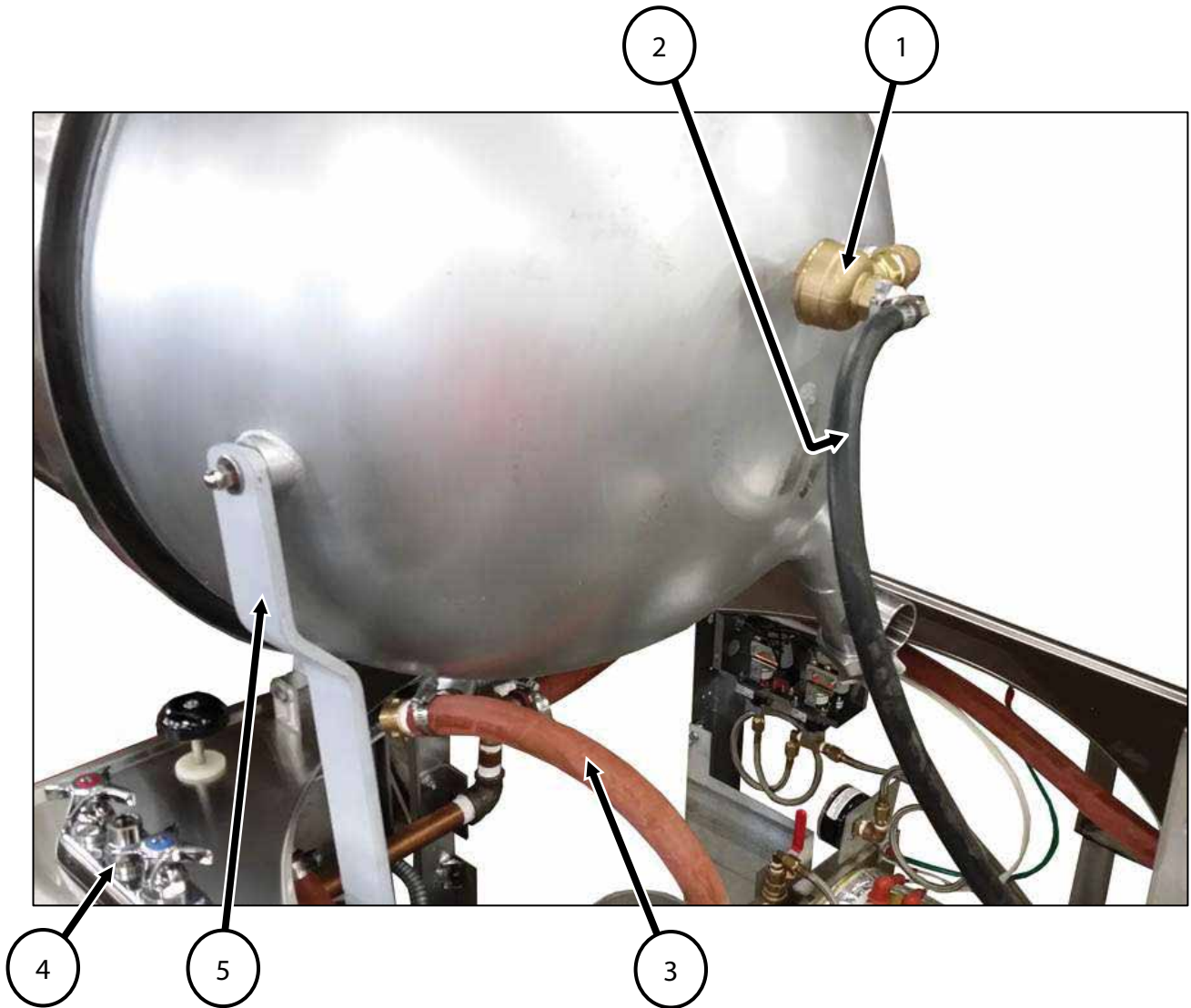

ITEM	PART NO.	DESCRIPTION
1	10-5319	STEAM TRAP
2	90-7493	RUBBER HOSE, 3/8 ID X 40" LONG
3	90-7495	RUBBER HOSE, 3/4 ID X 36" LONG
4	10-7680	FAUCET SET
5	98-0771	LIFT ARM, FOR 40 GALLON KETTLE
5	98-0599	LIFT ARM, FOR 25 & 60 GALLON KETTLE