

MSA-SB-2600 MILITARY SUB-ASSEMBLY HIGH EFFICIENCY ELECTRIC CONVECTION OVEN

OWNER'S MANUAL

MODEL:

- MSA-SB-2600

COVERING:

- INSTALLATION
- OPERATION
- SERVICE & PARTS

NSN: 9Z 7310-01-519-8399
APL: 43A040025
MF P/N: [98-3600](#) (No Drain)

NSN: TBD
APL: TBD
MF P/N: [98-3660](#) (Liner Drain)



*It is our policy to build equipment which is design certified by U.L. However, a continuing program of product improvement makes it necessary to submit new models to the agencies as they are developed and consequently not all models bear the appropriate agency labels at all times.

Form Number: S-4885 D 02/09

Printed in U.S.A.



35 Garvey Street • Everett • MA • 02149
Tel: (617) 387-4100 • Fax: (617) 387-4456 • Outside MA Fax: (800) 227-2659
E-Mail: CUSTSERV@mfii.com • Website: www.mfii.com

IMPORTANT NOTICE

NOTES:

1) Accutemp griddle mounting;

This version of the Installation Manual for the Market Forge oven model MSA-SB-2600 includes the (4) parts (listed below) that were modified in order to accept the Accutemp Griddle being mounted on top. All ovens shipped from the Market Forge factory with a Serial Number less than #226167 will require a back fit kit, Market Forge part number [98-4162](#), in order to mount the Accutemp griddle. The back fit kit includes the updated version of the (4) parts listed below and installation instructions. A simple replacement of these (4) parts with the back fit kit parts will allow the griddle to be mounted on top. The tools required to perform the replacement are a slotted screwdriver and a 7/16" socket wrench.

List of (4) parts that were modified to accept the Accutemp Griddle;

<u>Part Number</u>	<u>Description</u>
98-3571	RIGHT SIDE CHANNEL
98-3572	LEFT SIDE CHANNEL
98-3586	FRONT TOP PANEL
98-3587	REAR TOP PANEL

2) Replacement Reed Switch;

This version of the Installation Manual for the Market Forge oven model MSA-SB-2600 includes a new part number for the Reed Switch (sometimes referred to as a Proximity Switch). Due to alignment issues with the original Reed Switch a new, more forgiving Reed Switch is now being used. The new Reed Switch part number [08-6615](#) should be used as a direct replacement for part number [08-6308](#) in older model MSA-SB-2600 ovens.

All ovens shipped from the Market Forge factory with a Serial Number less than #225207 will have the original Reed Switch [08-6308](#). These can be directly replaced with the new Reed Switch [08-6615](#).

TABLE OF CONTENTS

IMPORTANT NOTICE	i
Your Energy Efficient Convection Oven	ii
How the Oven Operates	ii
Operating Controls and Indicators	1
Operating Instructions	1
Cleaning/Preventive Maintenance	2
Trouble-Shooting Guide	2-3
Illustrated Parts List	4-6
Assembly Instructions	7-19
Appendix	20-23

YOUR ENERGY EFFICIENT CONVECTION OVEN

MSA-SB-2600 convection ovens are electrically powered, high capacity ovens featuring high energy efficiency. These ovens are designed to radically cut power consumption, delivering the cooking power of a 16 KW oven from only 11 KW's of energy input. Improvement of energy use is made possible by a carefully designed insulating system which keeps heat inside the oven longer.

A convector fan distributes heat uniformly throughout the oven interior, for fast even roasting and baking.

Like all Market Forge products, MSA-SB-2600 ovens are built to the highest standards of workmanship, employing only the

finest materials and components. Of course, Power Saver II ovens are fully approved by UL, and other official testing authorities.

HOW THE OVEN OPERATES

MSA-SB-2600 ovens operate by use of two simple controls, a power switch for turning on the fan motor and control circuit, and a thermostat for setting the oven temperature. The oven is otherwise automatic. A thermostat maintains oven temperature by cycling heating elements on and off, with temperature fluctuating no more than 20°F from the setting. Uniform distribution of heat within the oven is assured by continuous operation of a convector fan.

A 60-minute and Constant Heat timer serves as an aid in using the oven, when the timer expires the heating elements shut off. To prevent unnecessary loss of heat when the doors are opened, an interlock switch stops fan operation whenever the

right-side door is opened. Should the operator wish to cool the oven, opening just the left- side door will quickly ventilate the oven interior.

OPERATING CONTROLS & INDICATORS

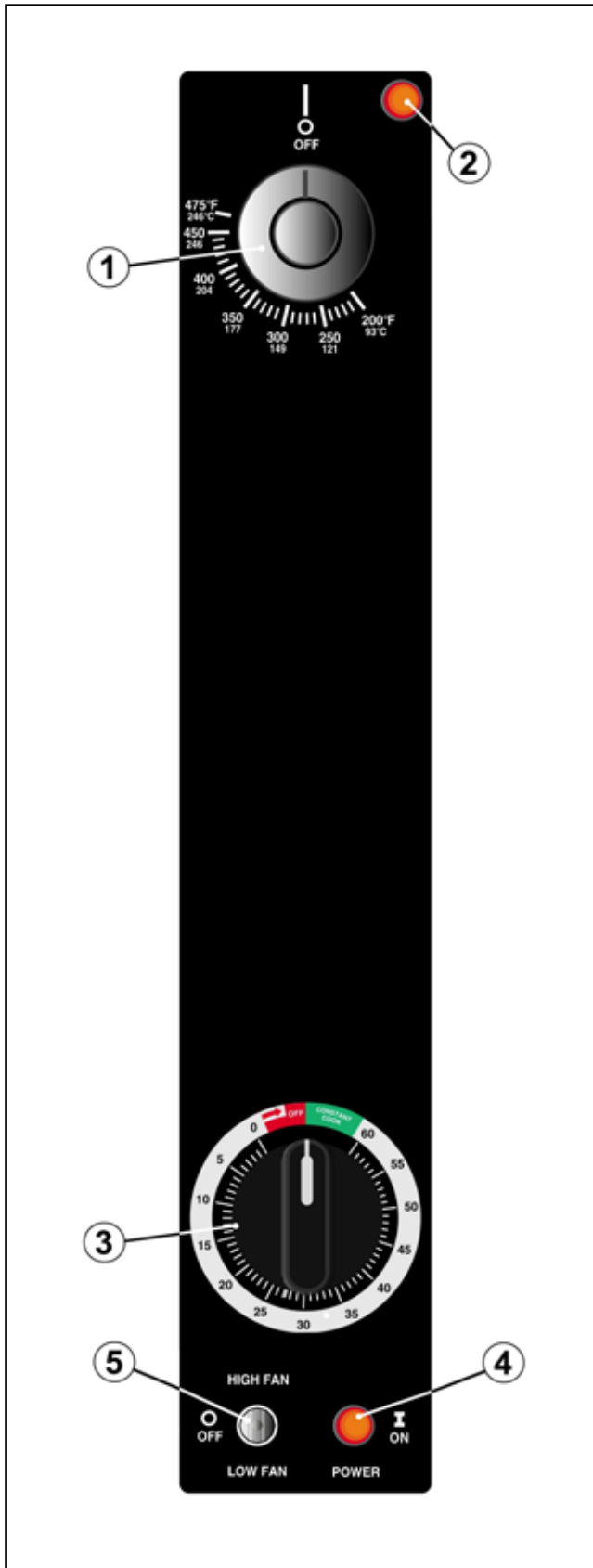

FIG. 1 Operating Controls & Indicators

The controls required to operate the oven are listed in the following table together with a short functional description of each. The physical location of each control is shown in FIG.1.

ITEM	DESCRIPTION	FUNCTION
1	Thermostat Control	Regulates oven temperature. Controls heating element operation.
2	Thermostat Light	Indicates when the thermostat is calling for heat and the elements are ON.
3	Timer/Constant Heat	Electrical timer to aid in time cooking cycles. Controls oven and constant heat mode.
4	Power Light	Indicates power is ON.

1. Check that power is available to the oven
2. Arrange shelf positions according to the item to be cooked.
3. Close doors. Move fan switch to HIGH or LOW. Fan should come on.
4. Set thermostat dial to desired cooking temperature. Element indicator light should come on
5. Allow oven to preheat for about 5-10 minutes. Preheating is complete when indicator light goes out and the buzzer sounds. Do not waste energy by turning the oven on too early.
6. Load oven. The load should be adjacent to the oven, so the doors will be open as short a time as possible.
7. Close doors. Set timer for desired cooking time.
8. Buzzer will sound at end of preset interval. Oven is ready to unload.
9. If oven temperature is to be lowered, set the thermostat to the desired temperature to cool interior. Fan will continue to run with left door open and right door closed. Where indicator light comes on, oven is at lower temperature. Close left door. When light goes off, oven is ready for use.
10. For daily shutdown, place oven thermostat and power switch in OFF position. For extended shut-

CLEANING/PREVENTIVE MAINTENANCE

A good preventive maintenance program in the form of daily cleaning procedures is outlined in the following steps:

1. Remove oven shelves and wash in mild detergent and water. Rinse and dry.
2. Remove left and right hand shelf supports by lifting up and out toward center of oven. Wash, rinse and dry.
3. Remove fan baffle by lifting up and out. Wash, rinse and dry.
4. Wash interior sides, bottom, and top with mild detergent and water. A stainless steel cleaner (not polish) should be used for the interior. Rinse and dry.
5. Replace fan baffle, shelf supports and shelves.
6. Wash both sides of doors, top & bottom trim using a stainless

steel cleaner. Rinse and dry.

TROUBLE-SHOOTING GUIDE

PROBLEM Probable Cause	REMEDY
CONVECTOR FAN FAILS TO OPERATE.	
a. Power to oven is off.	Locate external circuit breaker for power and place in ON position.
b. Power switch off.	Place in ON position.
c. Right oven door open.	Close Door.
d. Control circuit breaker off.	Place in ON position.
e. Faulty circuit breaker, door interlock switch, fan motor, or wiring.	Refer to wiring diagram or obtain outside service.
INDICATOR LIGHT FAILS TO LIGHT WITH FAN OPERATING, THERMOSTAT SET.	
a. Indicator light burned out.	Replace light. See service and parts manual for procedure.
b. Electrical failure.	Refer to wiring diagram or obtain outside service.
FAN OPERATION - NO HEAT.	
a. Thermostat not set.	Set thermostat.
b. Faulty contactor, wiring, electrical failure.	Refer to wiring diagram or obtain outside service.

TROUBLE-SHOOTING GUIDE

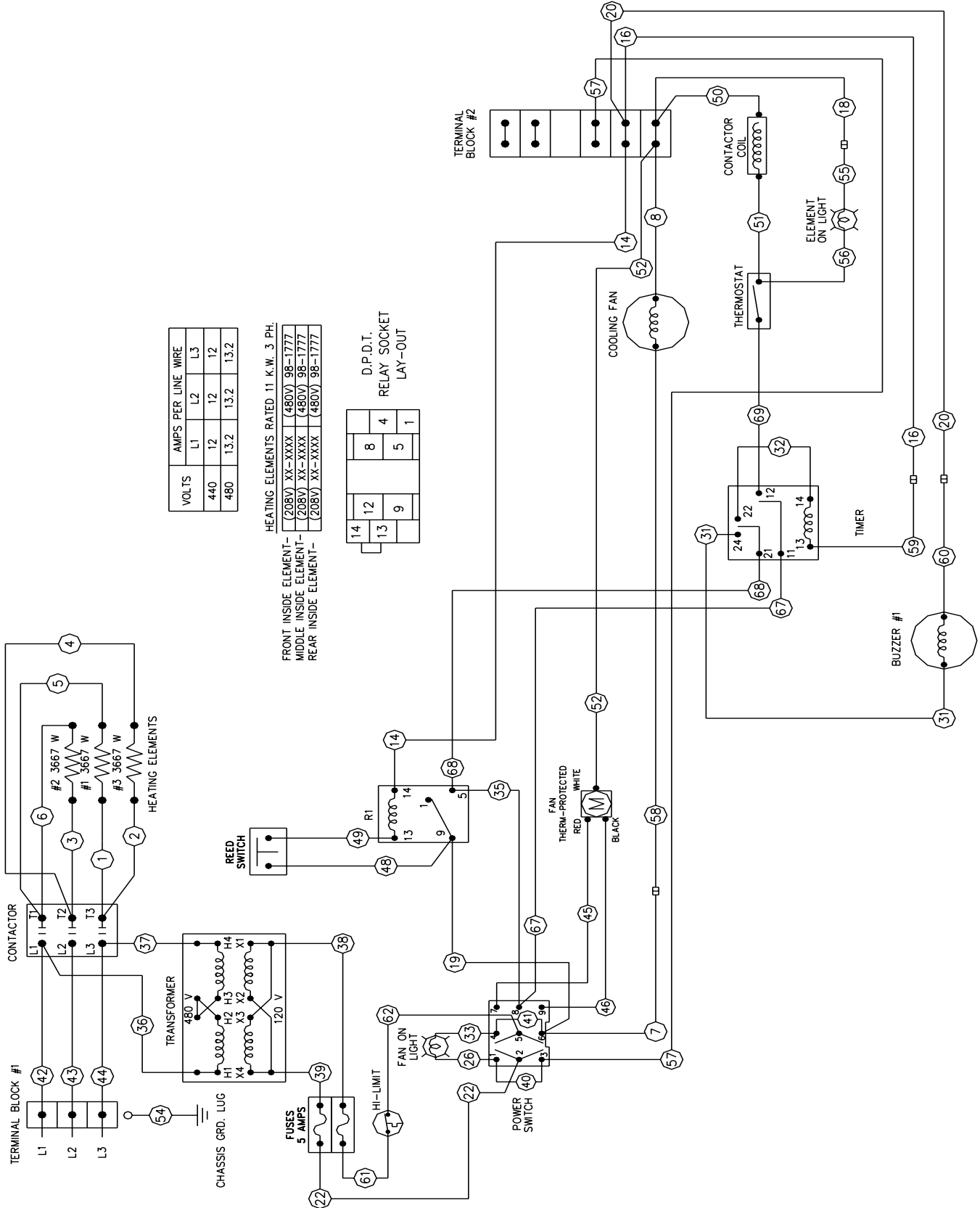

FIG. 2 Wiring Diagram

ILLUSTRATED PARTS LIST

RECOMMENDED SPARE PARTS LIST (P/N 98-3623)		
PART NO.	DESCRIPTION	QTY.
10-7371	SwitchPower/Fan	1
10-5052	Light, Fan Power	1
10-5052	Light, Heating Element	1
08-6615	Reed Switch	1
08-6472	Relay, 120V	1
08-6475	Relay, Socket	1
10-4714	Thermostat, 475°F	1
09-5259	Thermostat, Knob	1
08-6464	Timer	1
08-3826	Timer, Knob	1
10-5944	Contactactor	1
09-7248	Motor, 2 Speed	1
08-6351	Hi-Limit, Thermostat	1
08-6468	Fuse, 5Amp	2
09-6475	Transformer, 500VA	1
10-7395	Buzzer, 120 Volt	1
08-7978	Fan, Cooling	1
98-1777	Element, Heating (480V)	1
08-6469	Fuse, Holder	2

ILLUSTRATED PARTS LIST

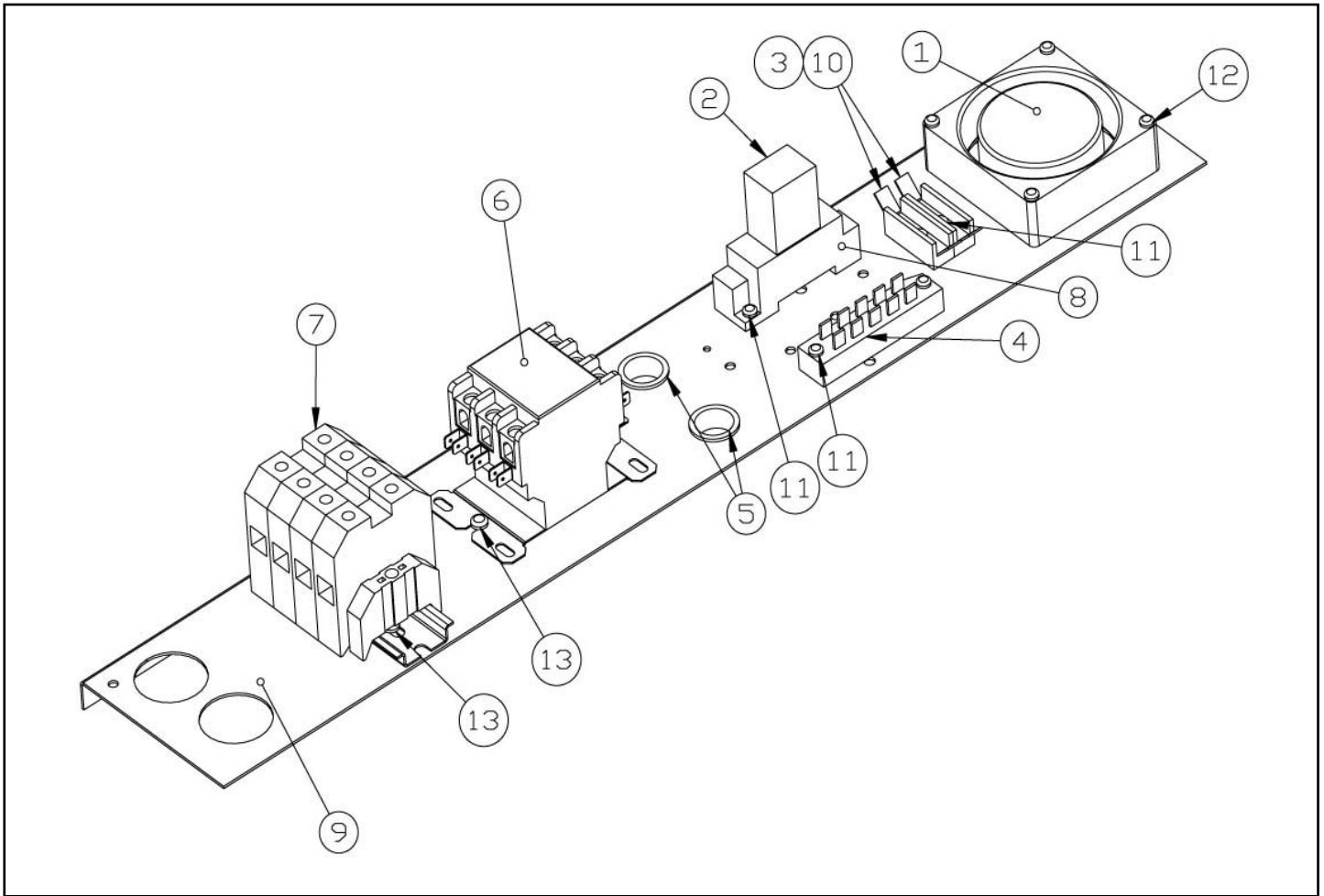

FIG. 3 Electric Control Panel with Probe Option

ITEM NO.	PART NO.	DESCRIPTION
1	08-7978	Fan, Cooling
2	08-6472	Relay, 120 Volts
3	08-6469	Fuse, Holder
4	08-6552	Terminal Strip
5	09-6575	Plug, Hole
6	10-5944	Contactor
7	98-1720	Terminal Block
8	08-6475	Relay, Socket
9	98-3562	Panel, Electric Controls
10	08-6468	Fuse, 5 Amps
11	10-1720	Screw, #6-32 Thread x 1/2" Long, Stainless Steel
12	08-7993	Screw, #6-32 Thread x 1 1/2" Long, Stainless Steel
13	10-1761	Screw, #8-32 Thread x 3/8" Long, Stainless Steel

ILLUSTRATED PARTS LIST

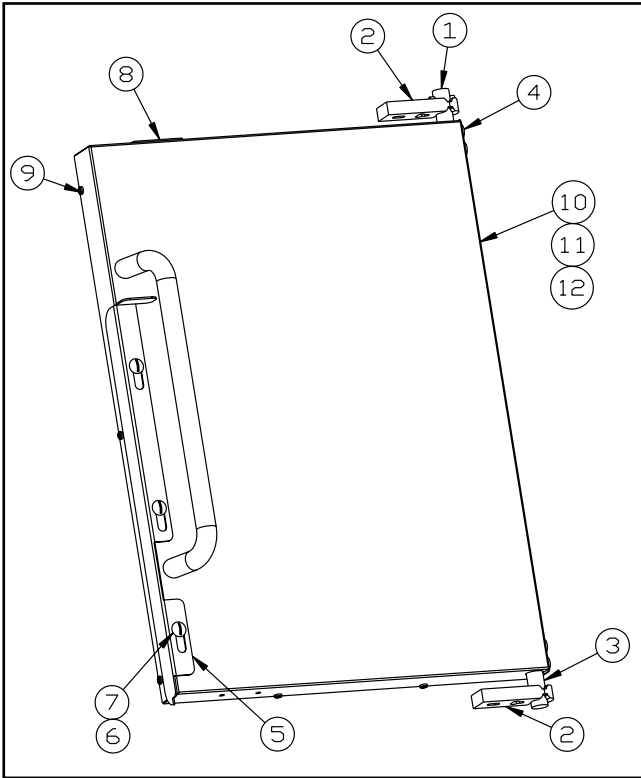

FIG. 4 Door Assembly with Slide Latch

ITEM NO.	PART NO.	FIG. 4 DESCRIPTION
1	98-3551	Pin, Door, Top with Pin
2	98-3552	Bearing, Block, Door Pin
3	98-5602	Pin, Door, Bottom, No Pin
4	09-3427	Hex Head Bolt, 1/4-20 Thd
5	98-3607	Bracket, Slide/Safety Latch
6	08-7990	Screw, 1/4-20 Thd Truss Hd 1/2" Lg
7	08-7989	Spacer, Door Slide
8	99-5950	Embossed Door Latch
9	10-2146	Screw, #6-32 1/4" Lg, Pan Head
10	98-3546	Inner Door Assy
11	98-3608	Outer Door, Left Side without Slide
12	98-3609	Outer Door, Right Side with Slide

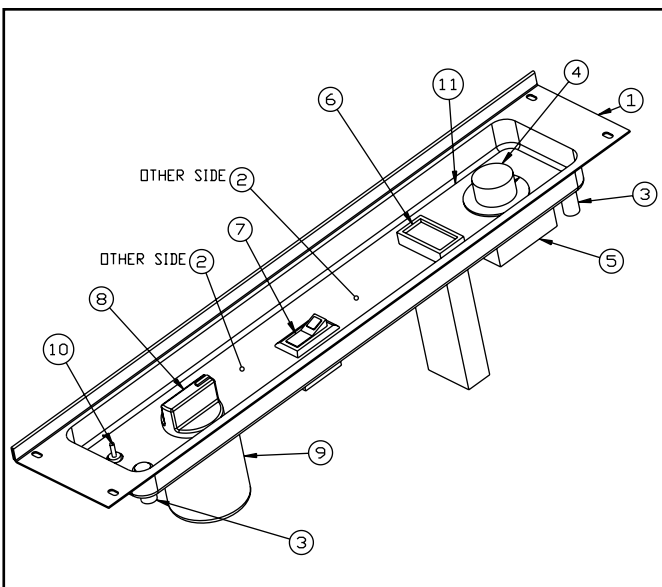

FIG. 5 Control Panel with Probe Option

ITEM NO.	PART NO.	FIG. 5 DESCRIPTION
1	98-1717	Control Panel, Embossed
2	10-7395	Buzzer
3	10-5052	Light, Power & Fan
4	09-5259	Knob, Thermostat
5	10-4717	Thermostat
6	08-7979	Controller, Meat Probe
7	08-6597	Switch, Mode
8	08-3826	Knob, Timer
9	08-6464	Timer
10	10-7371	Switch, Power/Fan
11	98-3543	Lexan, Control Panel, without Probe
12	98-1775	Lexan, Control Panel, with Probe

ASSEMBLY INSTRUCTIONS

SYSTEMS EQUIPMENT & ENGINEERING TEAM
Assembly Manual
Model: MSA-SB-2600, Market Forge Industries
Submarine-hatchable Convection Oven

INTRODUCTION

1. Oven, Sub-Assemblies & Tools.....	8
--------------------------------------	---

SUB-ASSEMBLIES

2. Main Frame Assembly.....	9
3. Oven Cavity Assembly.....	10
4. Control Panel Assembly.....	12
5. Motor/Transformer Assembly.....	14
6. Inside Oven Cavity Assembly.....	16
7. Door Assembly.....	17
8. Outer Skin Assembly.....	18

APPENDIX

A. Oven Performance.....	20
B. Wiring Diagram.....	20
C. Specification Sheet.....	21
D. Spare Parts List.....	22
E. List of Fasteners.....	23

ASSEMBLY INSTRUCTIONS

1 INTRODUCTION:

1.1 The model MSA-SB-2600: Submarine-Accessible Convection Oven contains 88 total parts for assembly and is designed such that it can be assembled in a submarine's galley with simple tools.

1.2 The total assembly is broken down into 7 sub-assemblies:

- Main Frame Assembly
- Oven Cavity Assembly
- Control Panel Assembly
- Motor/Transformer Assembly
- Inside Oven Cavity Assembly
- Door Assembly
- Outer Skin Assembly

1.3 The estimated time for complete assembly is approximately 6-7 hours for a first timer or 4-5 hours for an experienced assembler. The oven assembly can be completed with one person, but for a more productive assembly two people are recommended.

1.4 Tools required for assembly:

- Power drill (Cordless drills 12 V or higher)
- Screw driver set
- Screw starter
- Allen wrench set
- Socket Set
- Open wrench Set
- Mallet

1.5 Use RTV 106 high temperature silicone rubber adhesive sealant as needed to provide a tight seal to any area that requires it. Also use Loctite 268 on all fasteners that will be permanently fastened.



FIG. 6 Market Forge Sub-Oven

ITEM NO.	FIG. 7 DESCRIPTION	PART NO.
1	Split Base Front	98-3569
2	Split Base Rear	98-3568
3	Rear U - Channel Frame	98-3574
4	Front Frame Weld Assembly	98-3622
5	Frame Liner Support/Back Channel	98-3563
6	Channel, Frame Top Left Side, Front to Back	98-3572
7	Channel, Frame Top Right Side, Front to Back	98-3571
8	Channel, Motor/Transformer Support (2)	98-3590
9	Transformer Mounting Bracket	99-3291
10	Junction Box	98-3597

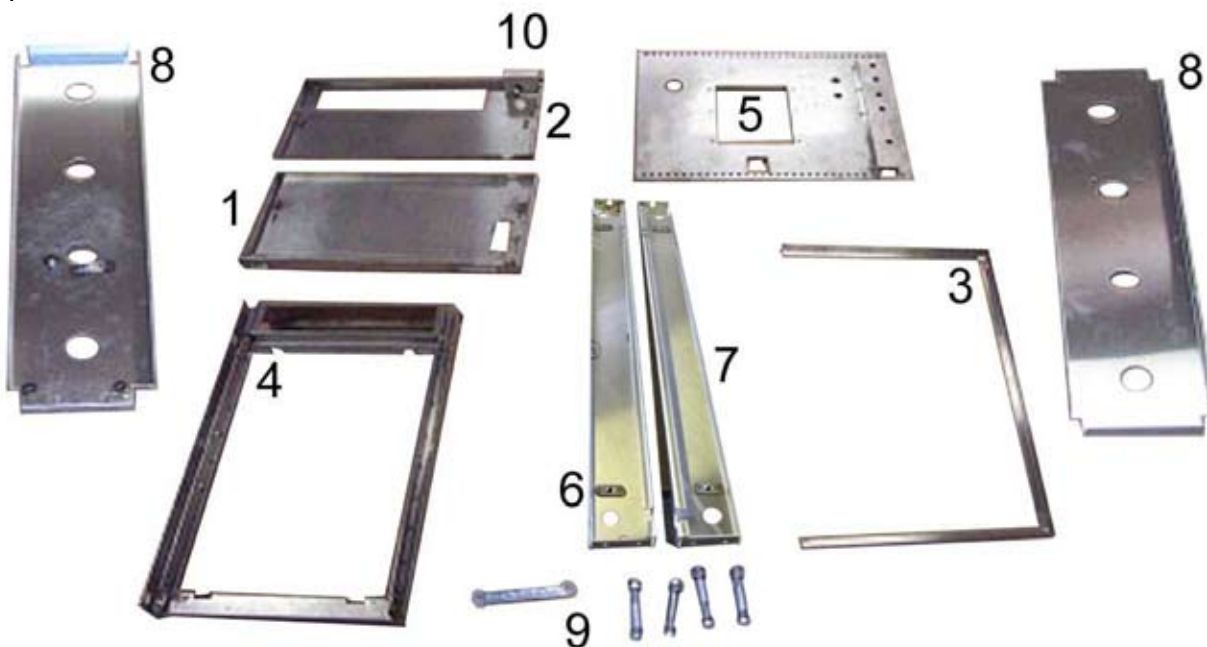

FIG. 7 Main Frame Assembly

ASSEMBLY INSTRUCTIONS

2.2 Bolt together the split base front (1) to the split base rear (2) using seven 1/4-20 hex bolts. Then fasten the Junction Box (11) to the split base rear using nuts.



FIG. 8 Split Base Front/Rear

2.3 Bolt front frame weld assembly (4) to split base front/rear using three 1/4-20 hex bolts at the base.



FIG. 9 Front Frame Weld Assembly

2.4 Bolt Rear U-channel frame (3) to split base front/rear assembly. There are welded bolts in the corner of the split base rear. Slip the rear u-channel over the bolts and use a two nuts to fasten it to the frame.



FIG. 10 Rear U-Channel Frame

2.5 Install the Frame liner support/back channel (5) with flanges facing to the rear of the oven and vent hole positioned on the left (Viewing from front of oven). This part will align over two welded slots but will NOT be fastened.



FIG. 11 Frame Liner Support/Back Channel

2.6 Bolt channel frame top (6), left side, and right side, front to back (7) to the Frame liner support/back channel and Rear U-channel frame. This will require six 1/4-20 hex bolts, two for each member.

NOTE: The backside needs only nuts since the bolts are welded to each part.



FIG. 12 Channel Frame Top, Left, & Right

2.7 Bolt two motor/transformer supports (8) to Frame liner support/back channel using 5/16"-18, 3-inch bolts with spacers and two 5/16"-18 nuts per spacer. Flanges must face inward towards each other.



FIG. 13 Motor/Transformer Supports

2.8 Bolt on the transformer-mounting bracket (9) to the bottom of the right (viewing from back end of oven) motor/transformer support (No picture), using two hex head screws.

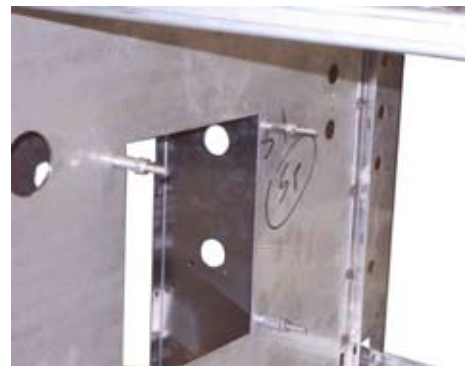

FIG. 14 Spacer with (2) Nuts

ASSEMBLY INSTRUCTIONS

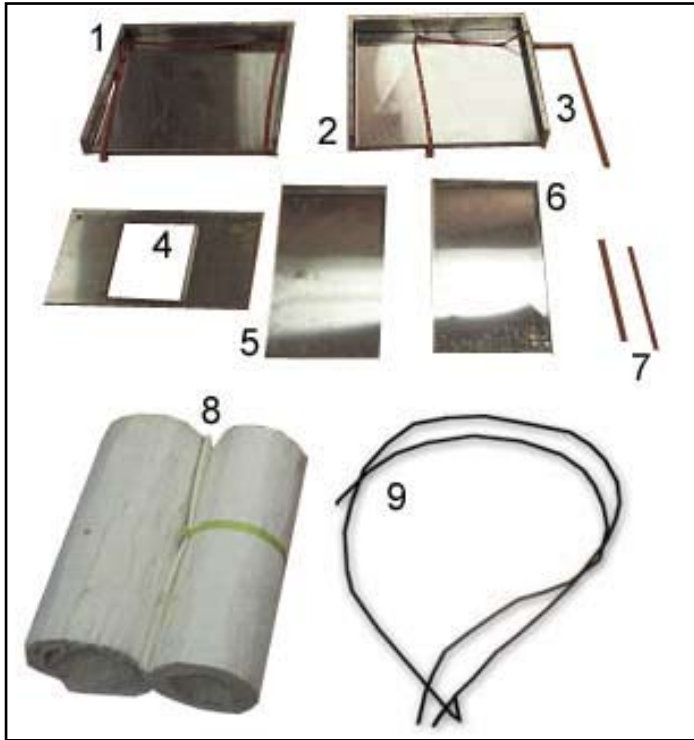

FIG. 15 Oven Cavity Parts

3 OVEN CAVITY ASSEMBLY:

ITEM NO.	3.1 Parts FIG. 15 DESCRIPTION	PART NO.
1	Split Liner Top	98-3576
2	Split Liner Bottom (Has 2 Crease Lines)	98-3655
3	U-Shaped Split Liner Gasket (2)	98-1796
4	Split Liner Rear	98-3579
5	Split Liner Left	98-3577
6	Split Liner Right (Has Slots in Corner for Heating Element)	98-3578
7	Vertical Split Liner Gasket (2)	98-1797
8	Cavity White Insulation (2)	15-7561
9	Insulation Straps with Clips (2)	
10	Rear Cavity Insulation (Not Shown)	98-3613
11	Top Cavity Insulation 1.5" Thick (Not Shown)	98-3619

NOTE: 15 Parts Total

3.2 Lay the split liner bottom (2) flat and place the U-shaped split liner gasket (3) around the split liner bottom.



FIG. 16 Split Liner Bottom with Gasket

3.3 Bolt on loosely the split liner rear (4) to the split liner bottom using 1/4-20 hex bolts. Then put the vertical split liner gasket (7) hanging on the top bolt of the left and right side.



FIG. 17 Split Liner Rear

3.4 Bolt the split liner left (5) and split liner right (6) to the split liner bottom and split liner rear.
NOTE: The split liner right has holes in it for the heating element.



FIG. 18 Split Liner Left & Right

3.5 Then place another U-shaped split liner gasket (3) around the top and finish by bolting the split liner top (1) to the rest of the cavity. Now fasten each and every bolt without moving the gaskets. Then apply silicon sealant to areas of need. As a reminder the front face flanges of the cavity must be flush.



FIG. 19 Split Liner Top & Bottom

ASSEMBLY INSTRUCTIONS

NOTE: The corner hole does not have a bolt. Otherwise interference will occur.



FIG. 20 Corner

3.6 Install rear cavity insulation (10) mounting over spacer bolts protruding from the frame liner support/back channel



FIG. 21 Rear Cavity Insulation

3.7 Install the whole cavity to the mainframe and secure with four #8-32 S.S hex nuts to the weld studs on the corners of the cavity thru the front frame weld assembly.



FIG. 22 Oven Cavity & Mainframe

3.8 Wrap the cavity with two layers of oven cavity insulation (8) starting from the right side of the oven and use two wire straps to fasten them down. Once insulated cut away insulation for heating element to exit from oven cavity.



FIG. 23 Oven Cavity & Insulation

3.9 Then add the top cavity insulation (11) to the top of the cavity. It will not be strapped down.



FIG. 24 Top Cavity Insulation

ASSEMBLY INSTRUCTIONS

4 CONTROL PANEL ASSEMBLY:

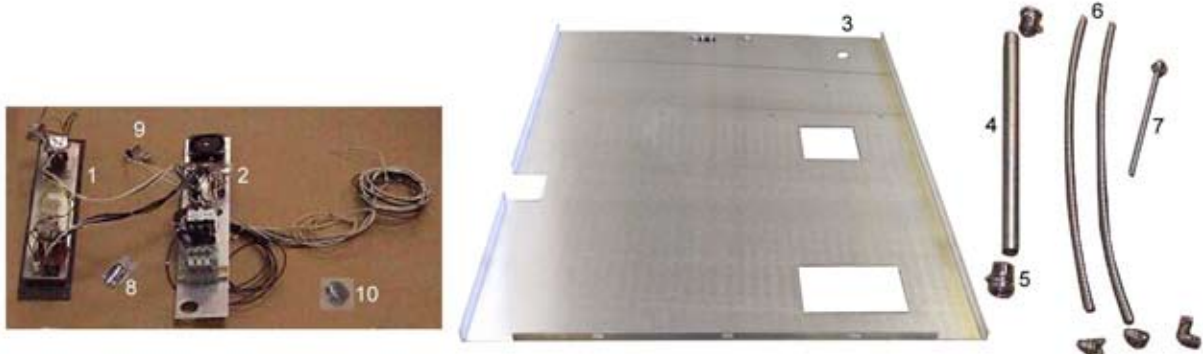

FIG. 25 Control Panel Parts

ITEM NO.	4.1 Parts FIG. 25 DESCRIPTION	PART NO.
1	Front Control Panel	98-3592
2	Electric Control Panel	98-3627
3	Inner Insulation/Electric Panel Divider	98-3575
4	Conduit Raceway Tubing	98-3596
5	Conduit Coupling (2)	10-8935
6	Flexible Conduit 32" (2)	
7	Flexible Conduit 12"	
8	High Limit Thermostat Mounting Bracket	99-4688
9	Reed Switch Bracket	98-3560
10	High Limit Thermostat	08-6351
11	Inner Insulation Panel Mounting Bracket (Not Shown)	98-3558

NOTE: 13 Parts Total

4.2 Bolt on the Inner insulation panel mounting bracket (11) to the inner insulation/electric panel divider (3) and then fasten it to the Frame liner support/back channel using three self-taping screws. Then fasten the nuts on the inner insulation panel mounting bracket where it sleeves over the front frame weld assembly.



FIG. 26 Inner Insulation Panel Mounting Bracket



FIG. 27 Sleeve to Front Frame Weld Assembly

4.3 Attach the reed switch bracket (9), which is part of the control panel to the insulation/electric panel divider.

NOTE: The position of the reed switch must be such that it is in the most forward position relative to the front of the oven.



FIG. 28 Reed Switch Bracket

4.4 Bolt the green ground wire of the front control panel (1) to the frame as seen in the picture. Use a #10-32 keps nut to fasten to the stud located behind the front frame weld assembly.



FIG. 29 Ground Wire

ASSEMBLY INSTRUCTIONS

- 4.5 Fasten the front control panel to the front frame weld assembly using four #8-32 pan head screws, one in each corner of the control panel face. Then attach the electric control panel (2) to the insulation/electric panel divider using three self-taping screws.



FIG. 30 Front Control Panel & Electric Control Panel

- 4.6 Install 2 conduit couplings (5) on the conduit raceway tubing (4) and install this combination to the electric control panel and junction box.

- 4.7 Then install the flexible conduit tubing for the high limit thermostat (7), motor (6), and transformer (6). The high limit thermostat has two lead wires that are white and is positioned through the third hole down from the top of the frame liner support/back channel. Do the same for the motor which has three wires numbered 45, 46 and 52. Then again for the transformer, which has four wires numbered 36, 37, 38 and 39 where the transformer conduit is on the bottom of the three.

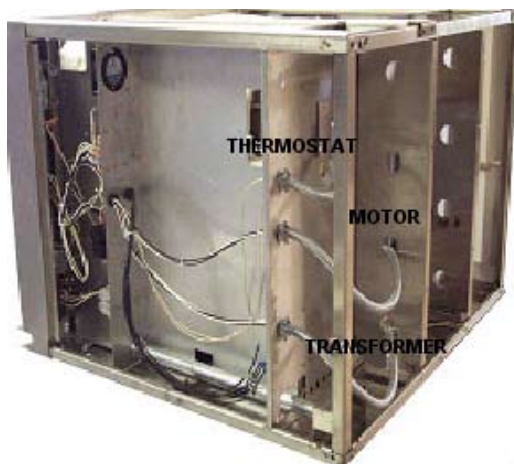

FIG. 31 Raceway & Flexible Conduit

NOTE: The tubing for the thermostat is 12" while the motor and transformer is 32".

- 4.8 Attach the high limit thermostat-mounting bracket (8) to the Frame liner support/back channel using two self-taping screws.



FIG. 32 High Limit Thermostat Mounting Bracket

- 4.9 Connect the high limit thermostat (10) to the two lead wires and then fasten to the inside of the cavity using two #6-32 screws.



FIG. 33 High Limit Thermostat

ASSEMBLY INSTRUCTIONS

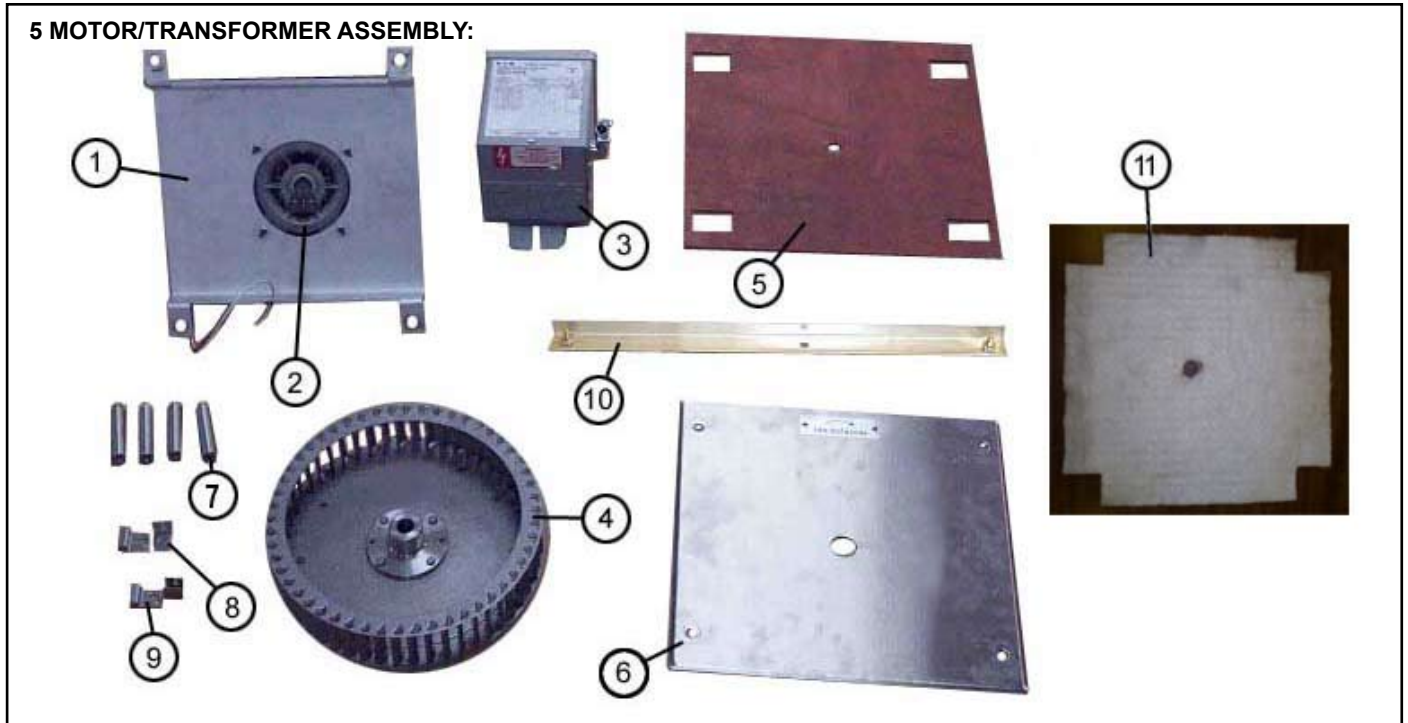

FIG. 34 Motor/Transformer Parts

ITEM NO.	5.1 Parts FIG. 34 DESCRIPTION	PART NO.
1	Motor Mount Bracket	99-3930
2	Motor	09-7248
3	Transformer	09-6475
4	Fan	98-3598
5	Motor Cover Plate Gasket	98-3566
6	Motor Mount Cover	99-3931
7	Standoff/Baffle with Screw (4)	98-3599
8	Thermostat Bracket Top	99-0950
9	Thermostat Bracket Bottom	99-0951
10	Support Brace Angle	98-3639
11	Motor Mount Insulation	10-0811

NOTE: 14 Parts Total

5.2 Attach motor (2) to the motor mount bracket (1). Then install this combination from the inside of the cavity with the motor wires positioned on the top. Do not bolt to cavity at this point.

NOTE:

There should be three spacer nuts between the motor and the motor mount bracket.



FIG. 35 Motor with Motor Mount Bracket

5.3 Place the white motor mount insulation (11) over the motor mount bracket. Tuck the left and right sides of the insulation down into the space on both sides of the motor mount bracket. Then place the motor cover plate gasket (5) over the motor mount gasket (placement is important since the gasket is NOT square).



FIG. 36 Motor Cover Plate Gasket

5.4 Install the motor cover (6) over the gasket. Then place the thermostat bracket top (8) over the top right bolt and the thermostat bracket bottom (9) over the bottom right bolt. Fasten all four using hex nuts.



FIG. 37 Motor Mount Cover

ASSEMBLY INSTRUCTIONS

5.5 Install the fan (4) over the motor shaft. Once positioned over the shaft use an allen wrench to fasten the fan to the shaft. Then install four stanoff/baffle's (7) with screw to the four bolts of the motor mount.

NOTE: Fan front surface and the end of the shaft face should be flush to each other as shown by the arrow.



FIG. 38 Fan

5.6 Install the transformer (3) where the bottom will slot into the transformer-mounting bracket. Then fasten down the top of the transformer to the motor/transformer support channel using two 1/4"-20 bolts. The transformer should be positioned as closely to the cavity as possible.



FIG. 39 Transformer

5.7 Have an electrician wire the motor and the transformer following the wiring diagram as in drawing number 98-3542, which is shown in Appendix A, page 20 of this manual.

5.8 Install the support brace angle (10) to the motor/transformer support channels. Tighten in place.



FIG. 40 Support Brace Angle

ASSEMBLY INSTRUCTIONS

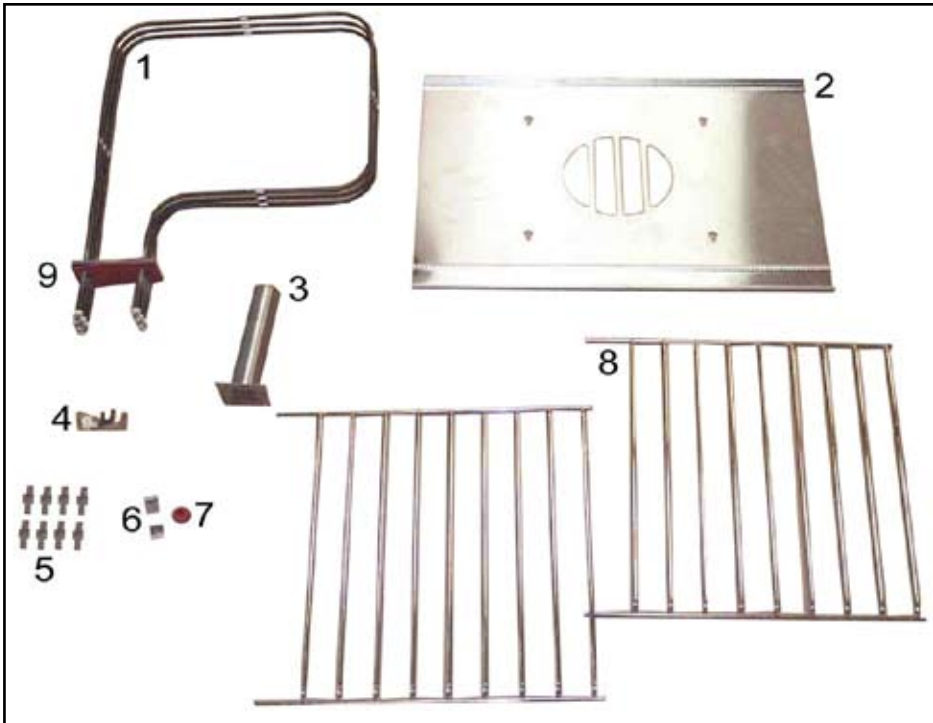

FIG. 41 Inside Oven Cavity Parts

6 INSIDE OVEN CAVITY ASSEMBLY:

ITEM NO.	6.1 Parts FIG. 41 DESCRIPTION	PART NO.
1	Heating Element (480 V)	98-1777
2	Baffle	98-1766
3	Vent Tub	98-3557
4	Element Support Bracket	98-3588
5	Side Rack Clip (8)	99-3097
6	Capillary Clip (2-3)	99-0953
7	Grommet	91-6491
8	Side Rack (2)	98-3621
9	Element Gasket	98-3561

NOTE: 18 Parts Total

6.2 Install the vent tube (3) using four self-taping screws. Then install the side rack clips (5), four on each side of the oven and use two self-taping screws per clip.



FIG. 42 Vent Tube & Side Rack Clips

6.3 Install the element support bracket (4), which will be to the left of the fan, using two self-taping screws.



FIG. 43 Element Support Bracket

6.4 Install the grommet (7) on the right side of the cavity. Then punch a hole through the grommet and CAREFULLY unwind the thermostat capillary tube located behind the front control panel and feed it through the grommet and into the cavity.

Run the capillary tube along the top of the cavity to the back and down through the thermostat brackets. Use capillary clips (6) to fasten the tube using self-taping screws.



FIG. 44 Capillary Clips & Grommet

ASSEMBLY INSTRUCTIONS

6.5 Place the element gasket (9) on the heating element (1) and install using four allen set screws. Bolt down the element using #8-32 keps nuts.



FIG. 45 Heating Element with Gasket & Fasteners

6.6 Connect the heating element to the proper cables as indicated in the wiring diagram located in Appendix A of this manual (6 wires).



FIG. 46 Heating Element Connection

6.7 Attach the baffle (2) and side racks (8) to the inside of the oven cavity as shown. Use four 1/4"-20 shoulder bolts for the baffle.



FIG. 47 Baffle & Side Racks

7 DOOR ASSEMBLY:

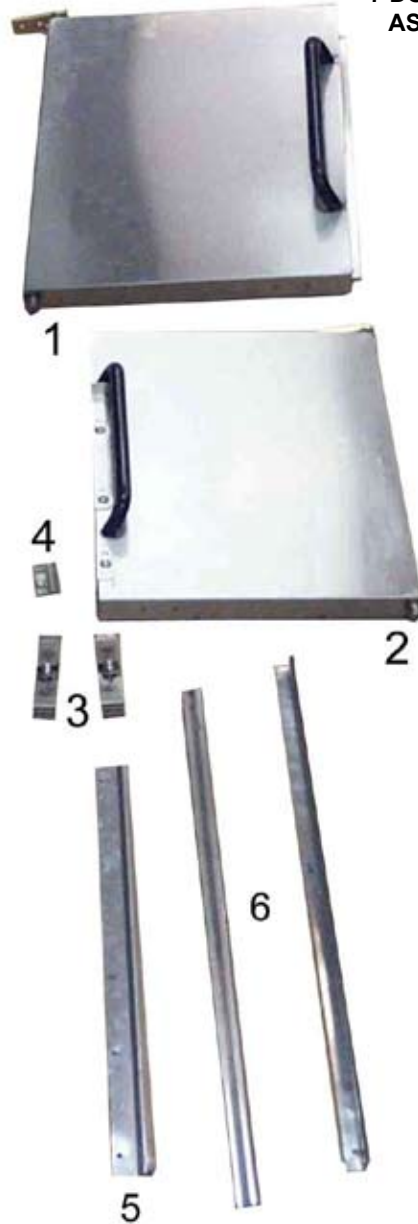

FIG. 48 Door Assembly Parts

ITEM NO.	7.1 Parts FIG. 48 DESCRIPTION	PART NO.
1	Left Door	98-3629
2	Right Door	98-3589
3	Door Top Latch (2)	99-5946
4	Door Lock Latch	98-3595
5	Left & Right Vertical Door Liner Gasket (2 pieces)	98-3611
6	Horizontal Door Liner Gasket (2)	98-3610

NOTE: 9 Parts Total

ASSEMBLY INSTRUCTIONS

7.2 Install horizontal liner gasket (6) on top and bottom of the front frame weld assembly using #8-32 pan head screws.

7.3 Install left and right vertical door liner gaskets (5) using #8-32 pan head screws.

7.4 Install the two door top latch (3) in the top-middle of the front frame weld assembly using #8-32 countersunk screws.

7.5 Install left and right door (1-2). Fasten door bearing using #10-32 flat head countersunk screws and nuts.

NOTE: Adjust doors as necessary to properly align them. may require a few adjustments. This is very important. Door lock latch (4) will not be installed at this time.



FIG. 49 Door Liner Gaskets



FIG. 50 Door with Bearings

8 OUTER SKIN ASSEMBLY:

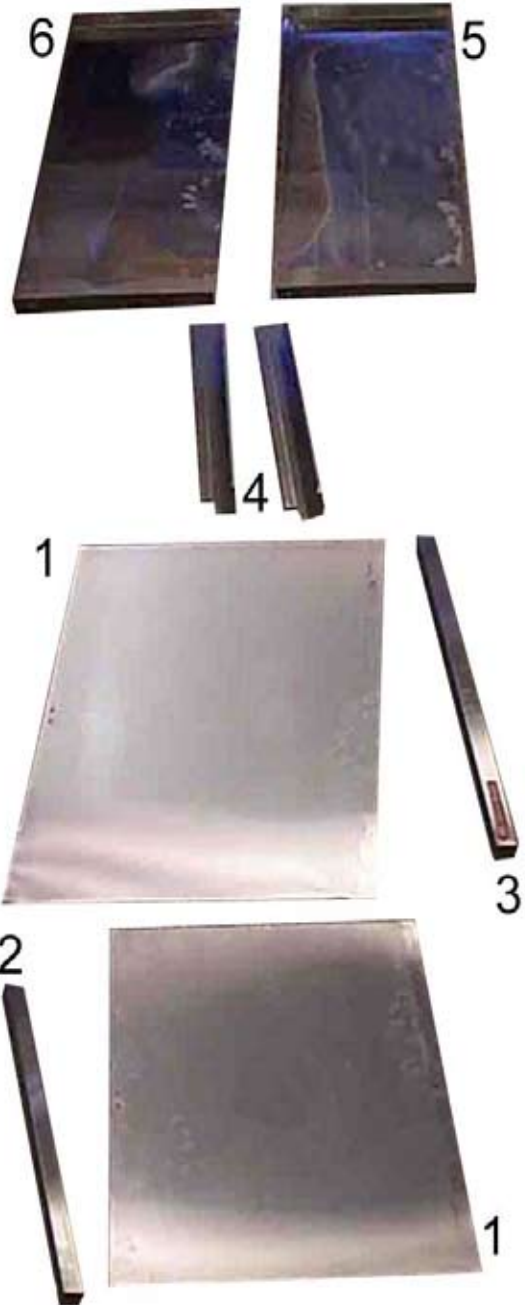

FIG. 51 Outer Skin Parts

ITEM NO.	8.1 Parts FIG. 51 DESCRIPTION	PART NO.
1	Side Frame Skin (2)	98-3624
2	Bottom U-Channel Cover	98-3585
3	Top U-Channel Cover	98-3643
4	Corner Channel Cover (2)	98-3581
5	Split Top Rear Cover	98-3587
6	Split Top Front Cover	98-3586

NOTE: 8 Parts Total

ASSEMBLY INSTRUCTIONS

8.2 Install the bottom u-channel cover (2) and the top U-channel cover (3) to the front frame weld assembly. No screws or bolts needed. Just pop in the parts.



FIG. 52 Top & Bottom U-Channel Cover

8.3 Install door lock latch using #8-32 quarter pan head screws.

NOTE: Close door and adjust as needed.



FIG. 53 Door Lock Latch

8.4 Install two, corner channel cover's (4) using two #8-32 pan head screws on the bottom only.



FIG. 54 Corner Channel Cover

8.5 Have an electrician wire a power supply line through the raceway conduit rates at 480 VAC, 3 Phase.

8.6 Install the side frame skin (1) on the right and left side of the oven. Use one #8-32 pan head screw per side.



FIG. 55 Split Top Rear Cover

8.7 Install the split top cover (5) and screw the rear corner to the corner channel using two #8-32 pan head screws per corner.

8.8 Lastly install the split top front (6) and fasten to the split rear using seven #8-32 quarter pan head screws.



FIG. 56 Split Top Front Cover

APPENDIX

A. OVEN PERFORMANCE

A.1 Verification Check List

1. Verify that the doors are properly aligned and that there is no interference occurring at room temperature and 400°F.
2. Verify that all screws and bolts are tight.
3. Verify that the blower fan can operate at high and low speeds.
4. Clean oven with a rag and run oven for 2 hours to burn off oil, clean interior prior to use.
5. Verify that the racks do not bind at 400°F.

Verify the accuracy of the oven's thermostat at 350°F by comparing the temperature control setting to the temperature at the center of the oven (one thermocouple). The maximum difference is to be no more than +/- 50°F.

Wiring Diagram - 480 V, 3 Phase, 11 kW, 60 Hz
Sub-Oven, Convection Oven, No Probe.

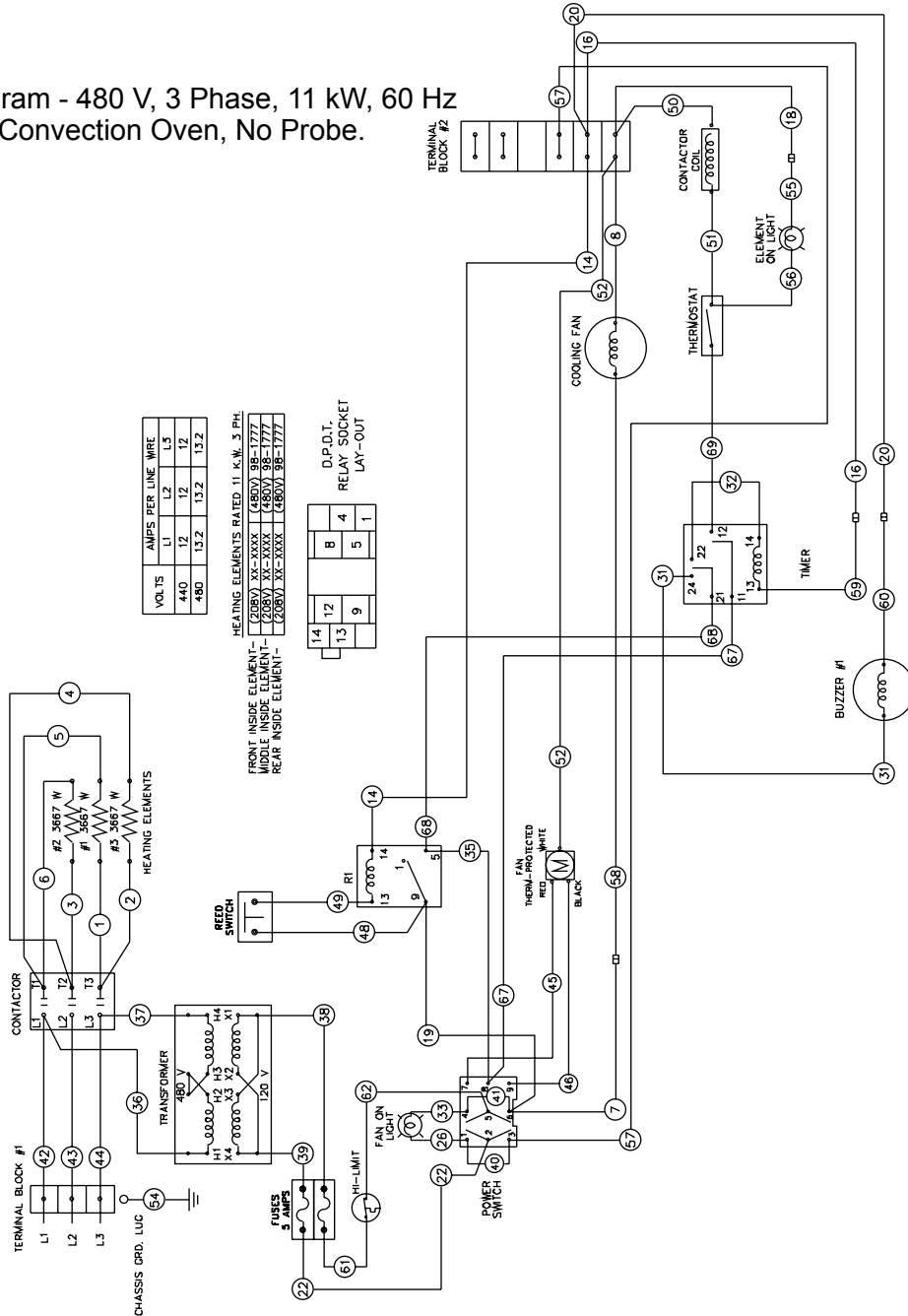

FIG. 57 Wire Diagram

RE V.	A
C	98-3542
	DRAWING NUMBER

APPENDIX

MODEL: MSA-SB-2600

SIZE: 35 1/4" Deep x 36" Wide x 25 1/4" High
(896mm Front-to-Back x 914mm Wide x 641mm Top-to-Bottom)

DESCRIPTION: Will be a Market Forged Military Sub-Accessible High Efficiency Electric Convection Oven equipped with COOK & CONSTANT COOK controls. CONSTANT COOK permits operator to preset oven to cook food at a constant temperature for a infinite amount of time.

Exterior will be finished with stainless steel panels, top, rear, sides. Oven liner will be wrapped with a minimum .75" (19mm) High-Grade insulation. French type doors will open a full 180° and will be: Stainless steel with a minimum of .75" (19mm) insulation.

Oven interior dimensions will be 27 3/8" wide x 20" high x 24 5/8" deep (695mm wide x 508mm high x 625mm deep).

Oven interior will be stainless steel with coved corners and a water-proof design. Oven shelves and shelf supports will provide nine shelf positions centered 2" (51mm) apart. Shelf stops on oven shelf will prevent tipping within the shelf supports. Five shelves will be furnished as standard. Safety door latch designed to keep doors closed in any pitch and roll environment is included.

Controls will be located on an embossed recessed panel on the right front of oven. Controls will include main power switch, thermostat with indicator light and temperature range of 200°-475°F (93°-246°C), mechanical 60-minute and Constant cook timer with audible alarms that sound at end of the preset interval. A 2-speed fan selector switch with HIGH or LOW modes. Controls will also include a high limit cut-off.

Convector fan will turn on automatically when power is on and right door is closed. Fan will turn off automatically when right door is opened. For rapid cooling purposes, it will be possible to operate convector fan with left door open in order to quickly evacuate heated air from oven. Convector fan motor will be rated at 1/4 HP.

Oven will be completely serviceable from the front. Back of oven will be completely enclosed and suitable for installation tight against a non-combustible wall.

OPERATION WILL BE BY:

Oven will be rated at 11 KW, and equipped for operation on:

- 480 VAC, 3 pH

Oven controls will operate on nominal 120 volts AC.

OPTIONAL AT EXTRA COST:

- Extra shelves _____ quantity.
- Meat Probe/Thermometer.
- 1 3/4" Diameter Liner Drain.
- Legs (4) with Flanged Feet (3/4-10" Thread).

EC	Electrical Connection - Connection for incoming power supply wires on terminal block.		
EP	Power Supply - 1 3/8 (44mm) Ø access holes for power supply wires. Use wire suitable for at least 90°C. Nominal amp per line wire per oven: 11kW.		
VOLTS	1pH	3pH	
480 (440-480)	----	15	

Details of other electrical systems available upon request.

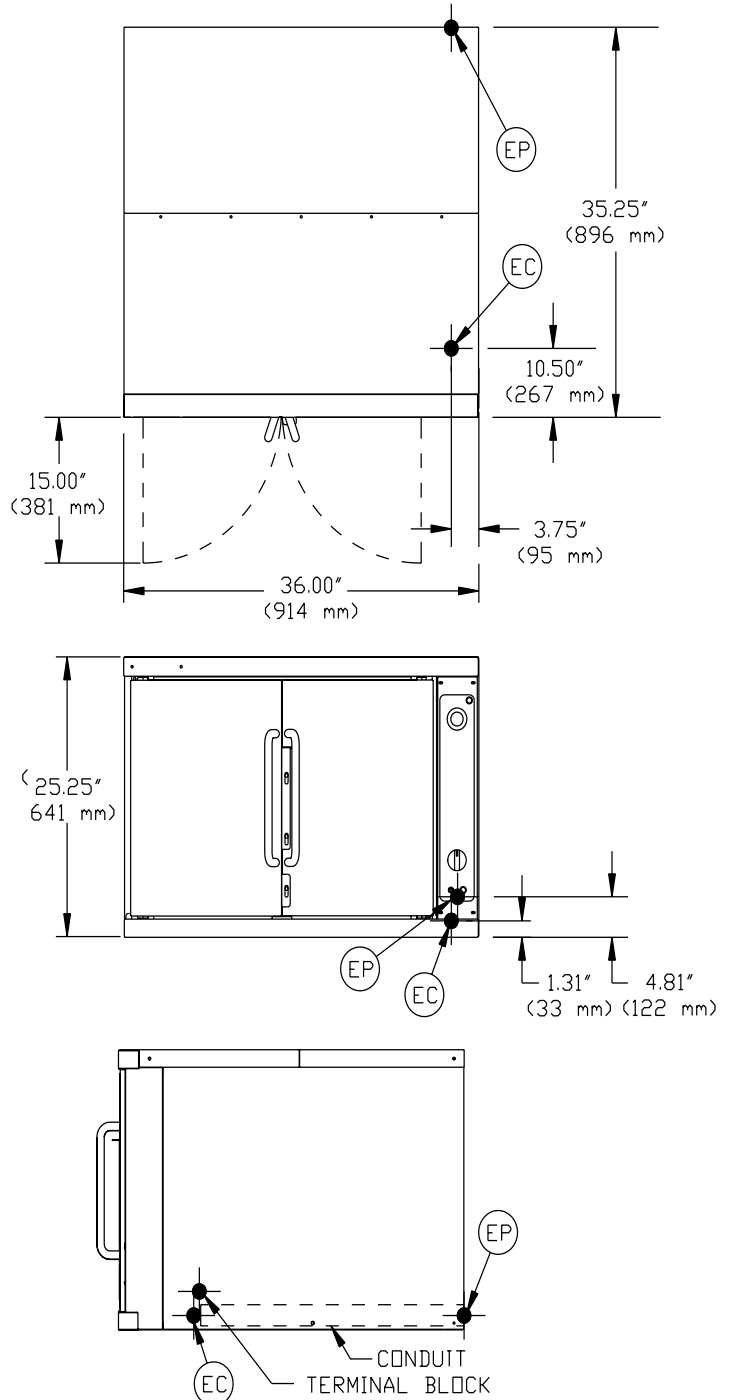

APPENDIX

PART NO.	SPARE PARTS LIST DESCRIPTION	QTY.
10-7371	Switch, Power/Fan	1
10-5052	Light, Fan Power	1
10-5052	Light Heating Element	1
08-6615	Reed, Switch	1
08-6472	Relay, 120 Volt	1
10-4714	Thermostat, 475°F	1
09-5259	Thermostat, Knob	1
08-6464	Timer	1
08-3826	Timer, knob	1
10-5944	Contactactor	1
09-7248	Motor, 2 Speed	1
08-6351	Hi-Limit, Thermostat	1
08-6468	Fuse, 5 Amp	2
09-6475	Transformer, 500 VA	1
10-7395	Buzzer, 120 Volt	1
08-7978	Fan, Cooling	1
98-1777	Element, Heating	1
08-8004	Loctite 268	1
08-8003	RTV 106 Silicone Sealant	1
08-7999	* Hardware Kit (Fasteners)	1
98-3623	Complete Spare Parts Kit	1
* NOTE: For individual fasteners refer below for specific part numbers.		

APPENDIX

PART NO.	PARTS LIST OF FASTENERS DESCRIPTION	LENGTH (inches)	THREAD SIZE	QTY.
10-1864	SCREW CAP HEX HEAD	0.5	1/4"-20	77
10-1814	SCREW CAP HEX HEAD	0.75	1/4"-20	7
08-7840	NUT, SERRATED FLANGE		1/4"-20	73
08-7995	BOLT, HEX HEAD	3	5/16"-18	4
08-7956	NUT, SERRATED FLANGE		5/16"-18	8
10-2045	SCREW CAP HEX HEAD	0.5	#10-32	2
08-7996	TEK SCREW PHILLIPS PAN HEAD #2	0.5	#10-16	10
10-2146	SCREW, SLOTTED PAN HEAD	0.25	#6-32	26
10-1728	SCREW, PHILLIPS FLAT HEAD C-SUNK		#8-32	8
08-7994	SCREW, PHILLIPS FLAT HEAD C-SUNK	1	#10-32	8
10-1749	SCREW, MACHINE ROUND HEAD	0.25	#8-32	6
10-1761	SCREW, MACHINE TRUSS HEAD		#8-32	41
10-2571	NUT, KEPS		#8-32	20
08-8005	NUT, SERRATED FLANGE		#10-32	8
08-7992	SOCKET SET SCREW	1	#8-32	4
10-1790	SCREW, CAP HEX HEAD		1/4"-20	8
10-1939	BOLT, SHOULDER	0.5	1/4"-20	4
08-7991	SCREW, SLOTTED FLAT HEAD C-SUNK	0.5	#8-32	2
08-7990	SCRW, SLOTTED TRUSS HEAD	0.5	1/4"-20	3
08-3822	WASHER, STAINLESS STEEL TYPE B		1/4"	4