



# MARKET FORGE

## **ALTAIR II CONVECTION STEAM COOKER PARTS AND SERVICE MANUAL**

**EFFECTIVE MAY 4, 2017**

Superseding All Previous Parts Lists.

The Company reserves the right to make substitution in the event that items specified are not available.

ERRORS: Descriptive and/or typographic errors are subject to correction.

---

**MARKET FORGE**

Telephone: (802) 658-6600 Fax: (802) 860-3732

[www.marketforge.com](http://www.marketforge.com)

*P/N 14-0281 Rev C*

# TABLE OF CONTENTS

## WIRING DIAGRAMS

208/240 VAC.....	3
480 VAC.....	4

## ILLUSTRATED PARTS LIST

ELECTRICAL COMPONENTS.....	5
MODULE ASSEMBLY.....	6
CONTROL PANEL COMPONENTS & BTM ELEMENTS.....	7
DOOR ASSEMBLY.....	8
BLOWER DRIVE SYSTEM.....	10
BLOWER MOTOR ASSEMBLY.....	11
CAVITY PLUMBING COMPONENTS.....	12
DRAIN LINES & HEAT EXCHANGER.....	14
WATER INLET AND OUTLET.....	15
EXTERIOR COMPONENTS.....	16
INTERIOR COMPONENTS.....	18



# 480 VAC

A 6070-26  
REV. 05/11  
C

SYM	DATE	REV./EDM#	BY
A	05/05/11	UPGRADED STELLAR 1708 INITIAL RELEASE. ECH 10992	AJD

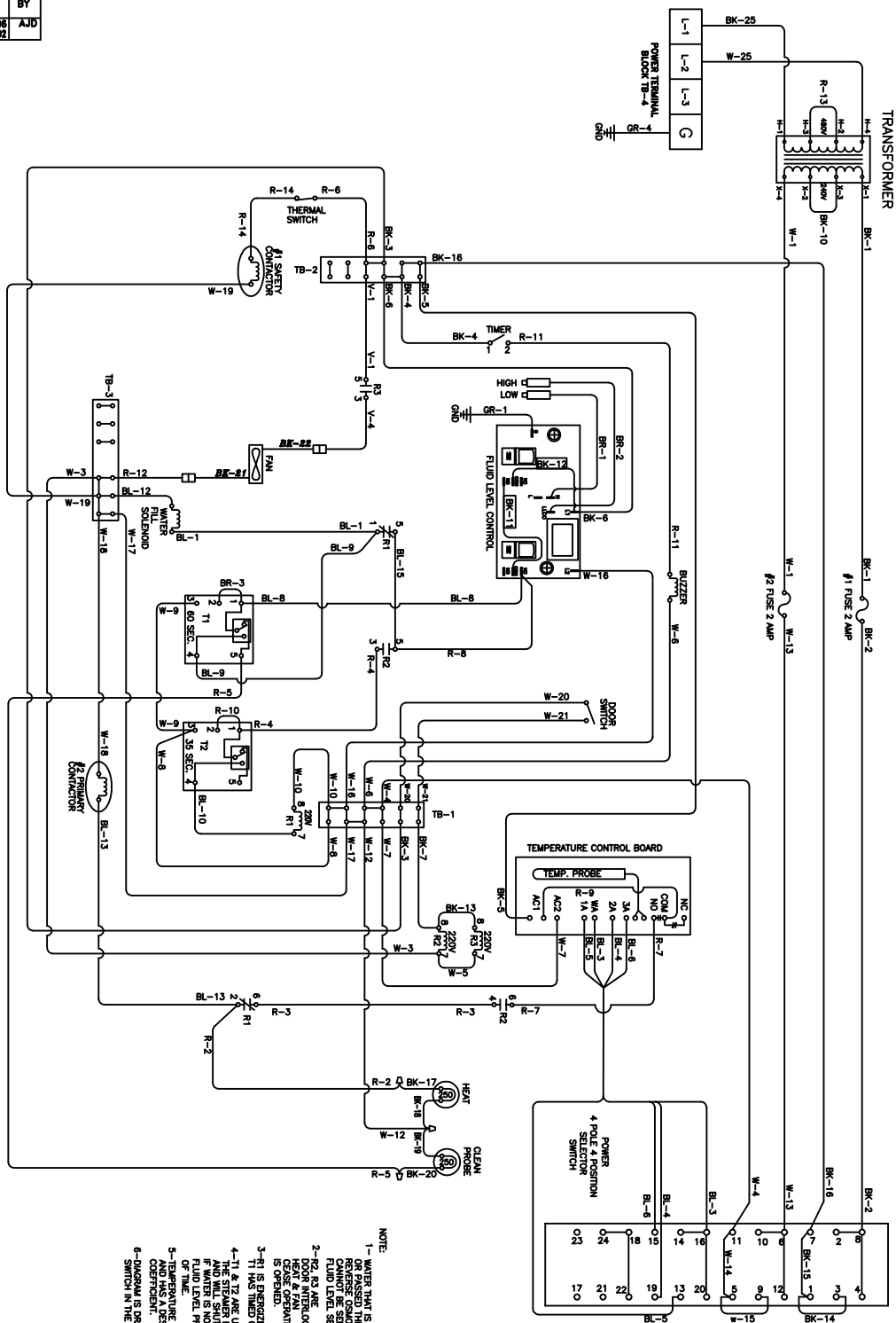

COLOUR CODE  
 BR - BROWN  
 BK - BLACK  
 BL - BLUE  
 GN - GREEN  
 GR - GREY  
 RD - RED  
 WH - WHITE  
 YL - YELLOW

TOLERANCES UNLESS OTHERWISE SPECIFIED	
FRACTIONS	± 1/32
.0	± .032
.00	± .015
.000	± .005
ANGLES	± 1°

USED ON ALTAR	EVERETT, MA. 02149 <b>MANITEX FORCE</b> WIRE DIAGRAM, ALTAR 4/6 PAN WATERFILL, FAN 480 VOLT, THREE PHASE
------------------	---

DRAWN AJD DATE 05/05/11	CHECKED  DATE  	SCALE  
----------------------------------	-----------------------------	---------------

AUTOCAD FILE NAME: 920709	SHEET NO. C	TOTAL SHEETS A
---------------------------	----------------	-------------------

- NOTE:
- 1- WATER TANK IS DE-IONIZED
  - 2- REVERSE CONVECTION SYSTEM, FLUID LEVEL SENSE SWITCH.
  - 3- T1 IS ENERGIZED WHEN DOOR IS OPENED.
  - 4- T1 & T2 ARE USED TO PREVENT THE STEAMER FROM OPERATING IF WATER IS NOT SENSED BY THE FLUID LEVEL PROBES IN A SET PERIOD OF TIME.
  - 5- T2 HAS A DESCENDING TEMPERATURE COEFFICIENT.
  - 6- DIAGRAM IS DRAWN WITH ROTARY SWITCH IN THE OFF POSITION.

# ELECTRICAL COMPONENTS

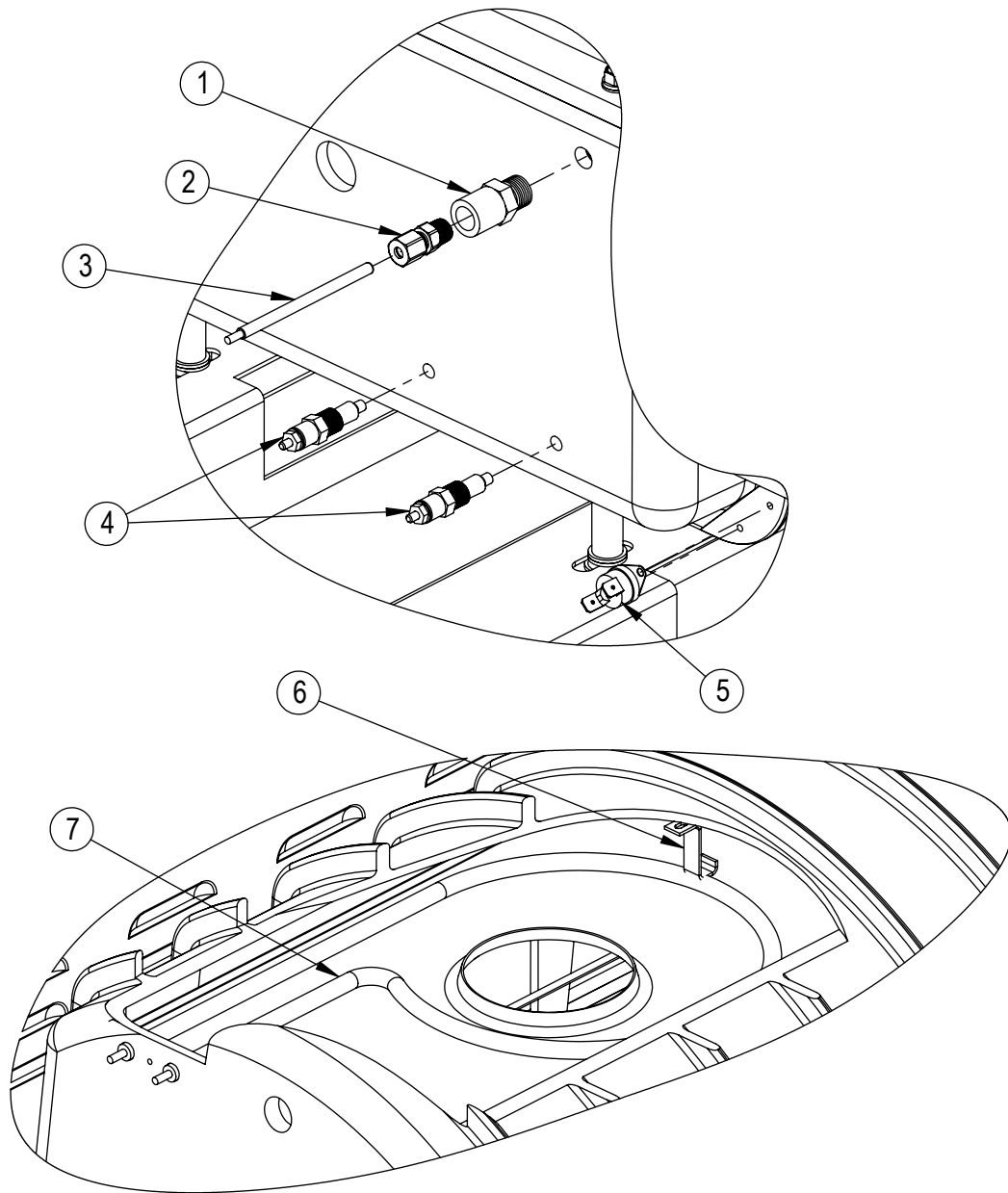

ITEM	PART	DESCRIPTION	QTY
1	92-0086	BUSHING, 1/4" NPT X 1/8" FNPT	1
2	92-0085	MALE CONNECTOR, 1/8" NPT X 3/16" COMP	1
3	92-0078	PROBE, THERMISTOR	1
4	92-0054	SENSE, WATER LEVEL	2
5	92-0175	THERMOSTAT, SNAP DISK, 240°F	1
6	92-0679	BRACKET, HEATING ELEMENT HANGER	1
7	92-0704	TUBULAR HEATER, 800W	1

# MODULE ASSEMBLY

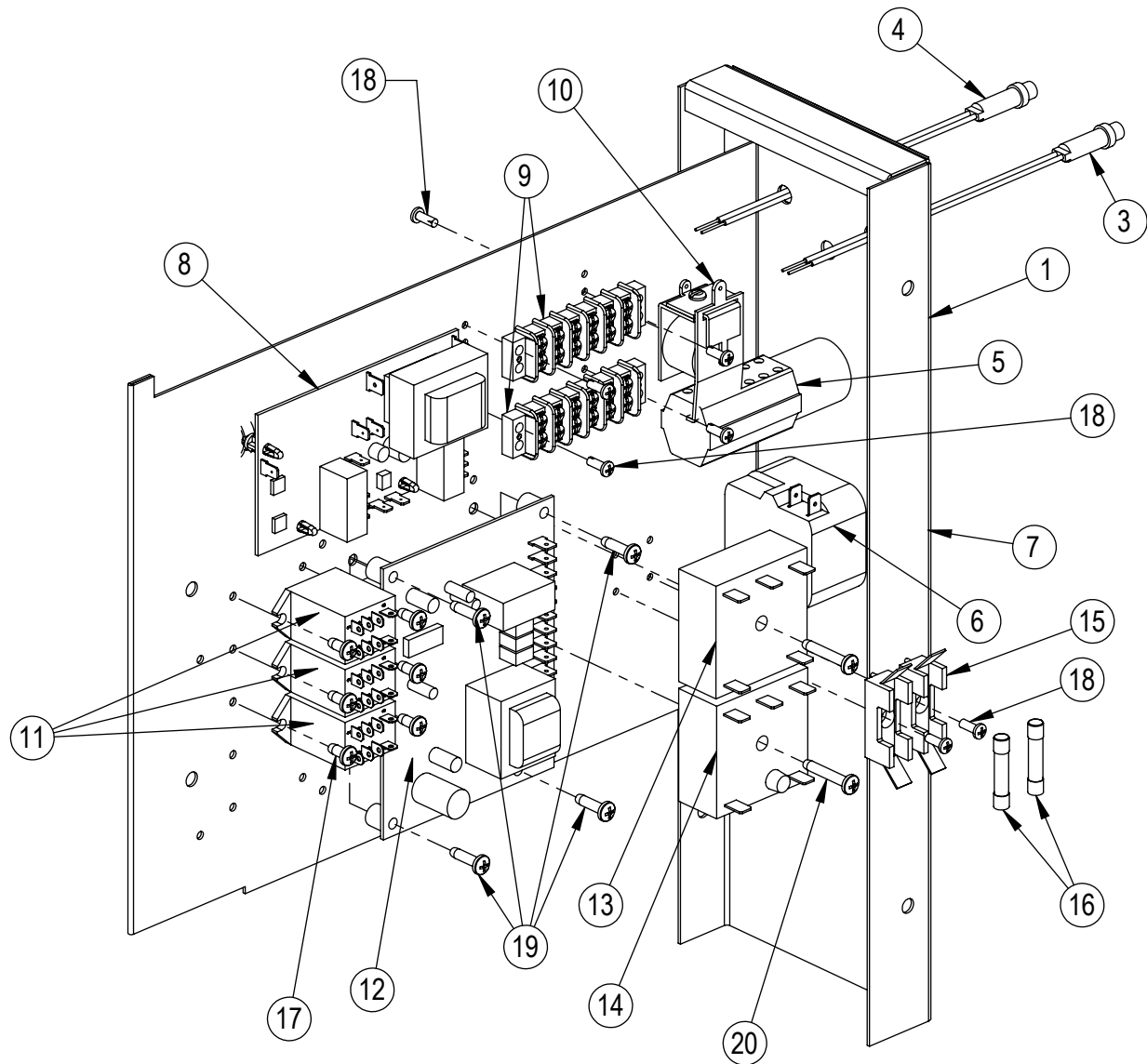

ITEM	PART	DESCRIPTION	QTY
1	92-0132	CONTROL PANEL, 4-PAN	1
2	92-0687	DECAL, CONTROL	1
3	92-0184	LIGHT, NEON, 250V, AMBER	1
4	92-0185	LIGHT, NEON, 250V, RED	1
5	92-0125	SWITCH, ROTARY	1
6	92-0137	TIMER, 60 MIN	1
7	92-0138	KNOB	1
8	92-0181	CONTROLLER, WATER FILL, 240V	1
9	92-0140	STRIP TERMINAL, 6 POLE	2
10	92-0186	BUZZER, 240V	1
11	92-0189	RELAY, 240V, DPDT	3

ITEM	PART	DESCRIPTION	QTY
12	92-0183	TEMPERATURE CONTROL BOARD, 240V	1
13	92-0188	TIMER, SOLID STATE, 60 SEC	1
14	92-0187	TIMER, DELAY ON MAKE, 230V	1
15	08-6469	FUSE HOLDER	2
16	92-0414	FUSE, 2A 250V TYPE O	2
17	20785	SCREW, TAP, 8-32 x 3/8, PH PAN HEAD	6
18	20636	TAP SCREW, 6-32 X 3/8" BRNZ-PLTD PAN	7
19	M3344	8-32 X 5/8 PAN HD SELF TAPPING SCREW	4
20	18269	8-32 X 1 PAN HD SELF TAPPING SCREW	2

# CONTROL PANEL COMPONENTS & BTM ELEMENTS

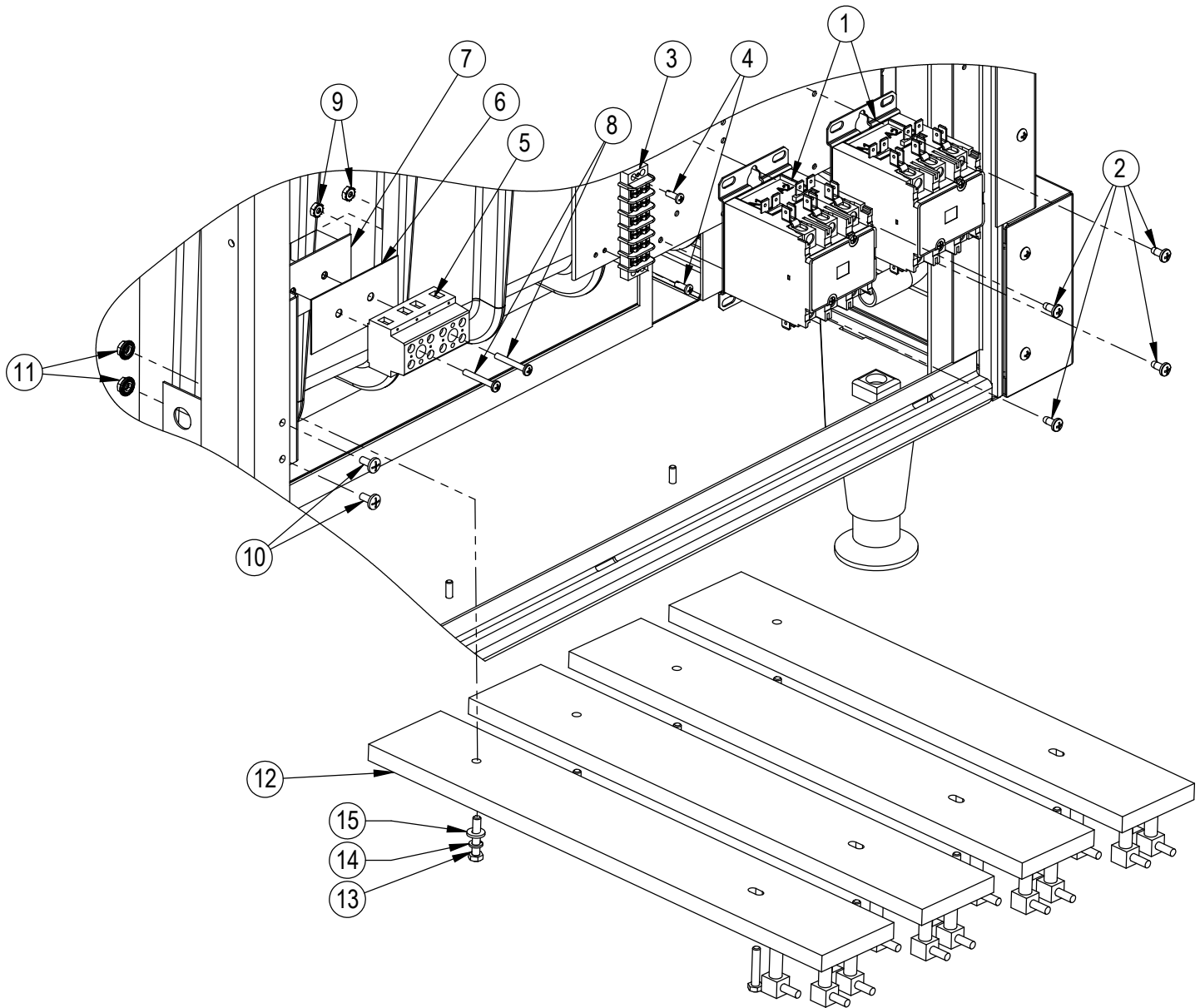

ITEM	PART	DESCRIPTION	QTY
1	10-5943	CONTACTOR, 40A, 600V, 3 POLE	2
2	20785	SCREW, #8-32 X 3/8", SELF TAP	1
3	92-0140	STRIP TERMINAL, 6 POLE	1
4	20636	SCREW, #6-32 X 3/8", SELF TAPPING	2
5	92-0069	TERMINAL BLOCK	1
6	92-0712	INSULATOR STRIP	1
7	92-0048	BRACKET, WATER INLET	1
8	16475	SCREW, #6-32 X 1", PAN HD	2
9	M3367	NUT, KEPS, #6-32	2

ITEM	PART	DESCRIPTION	QTY
10	39914	SCREW, #8-32 X 3/8", TRUSS HD	2
11	52378	NUT, #8-32 SERRATED FLANGED	2
12	92-0199	ELEMENT, 1800W, 208V	1
	92-0411	ELEMENT, 1800W, 240V	1
	92-0412	ELEMENT, 1800W, 280V	1
13	58109	SCREW, #10-32 X 1", HEX HD	8
14	M0418	WASHER, #10, SPLIT LOCK	8
15	M1820	WASHER, #10 FLAT	8

# DOOR ASSEMBLY

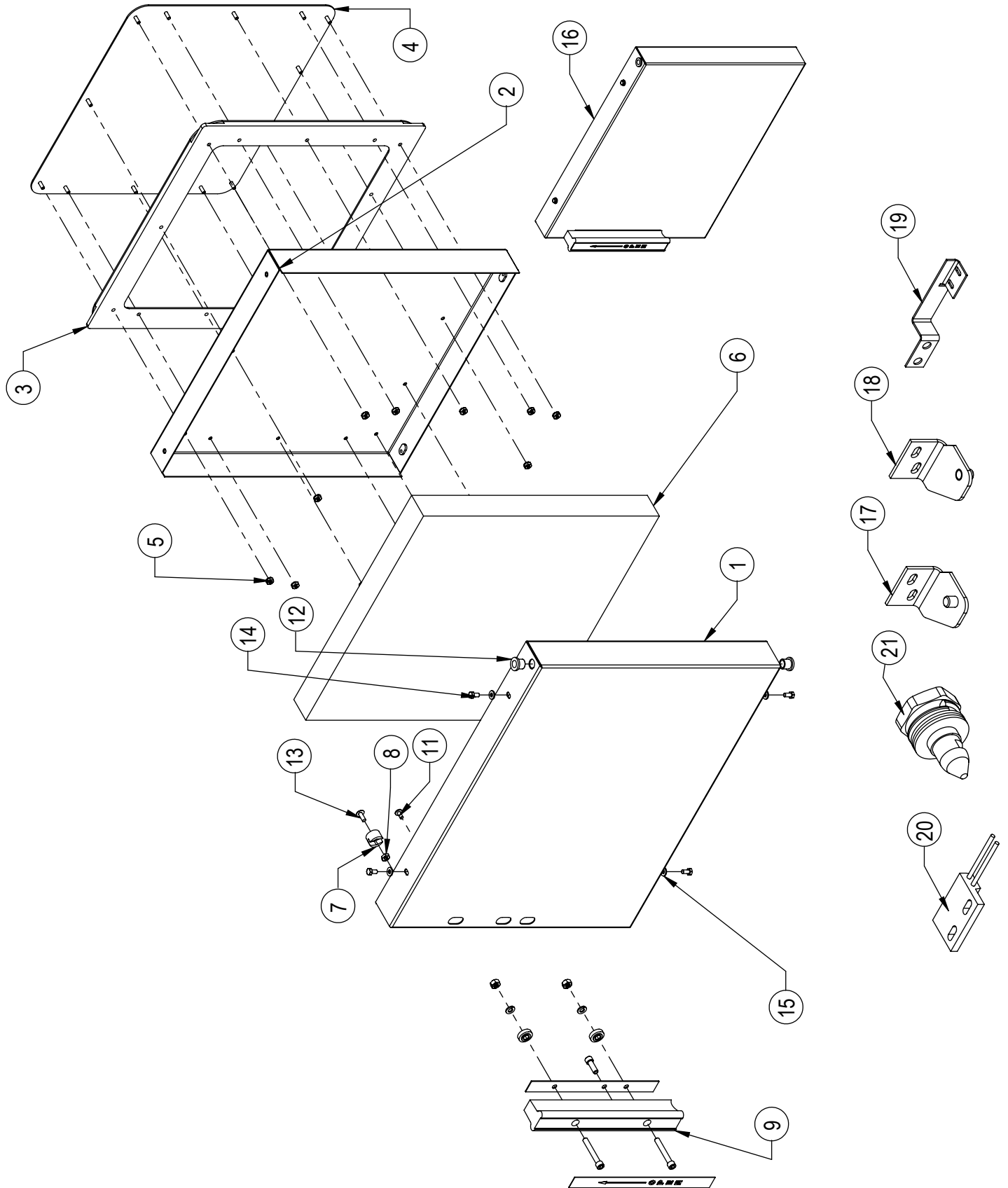

# DOOR ASSEMBLY

ITEM	PART	DESCRIPTION	QTY
1	92-0758	OUTER DOOR, 4 PAN STEAMER	1
	92-0754	OUTER DOOR, 6 PAN STEAMER	1
2	92-0759	ASSY, DOOR, INNER, 4 PAN STEAMER	1
	92-0755	ASSY, DOOR, INNER, 6 PAN STEAMER	1
3	92-0702	GASKET, 4 PAN STEAMER	1
	92-0703	GASKET, 6 PAN STEAMER	1
4	92-0761	RETAINER, GASKET, 4 PAN STEAMER	1
	92-0757	RETAINER, GASKET, 6 PAN STEAMER	1
5	51132	NUT, KEPS, #8-32 ZINC	13
6	14-0008	INSULATION, DOOR, 4 PAN STEAMER	1
	14-0009	INSULATION, DOOR, 6 PAN STEAMER	1
7	92-0067	MAGNET, DOOR SWITCH	1
8	4957	NUT, HEX, 10-24	1
9	97-6432	DOOR HANDLE	1
10	97-6232	LATCH ASSY	1
11	39914	SCREW, #8032 x 3/8 TRUSS PH	2
12	08-2712	BEARING, FLANGED	2
13	16384	10-24 X .500 TRUSS HEAD MACH SCREW	1
14	M0471	HEX HEAD CAP SCREW, #10-24	4
15	M1820	WASHER, FLAT, #10	4
16	92-0760	DOOR ASSY, COMPLETE, 4 PAN STEAMER	1
	92-0756	DOOR ASSY, COMPLETE, 6 PAN STEAMER	1
17	92-0744	HINGE ASSY, BOTTOM	1
18	92-0745	HINGE ASSY, TOP	1
19	91-7690	BRACKET, DOOR SWITCH	1
20	08-6308	SWITCH, PROXIMITY	1
21	97-6178	STRIKER, DOOR	

# BLOWER DRIVE SYSTEM

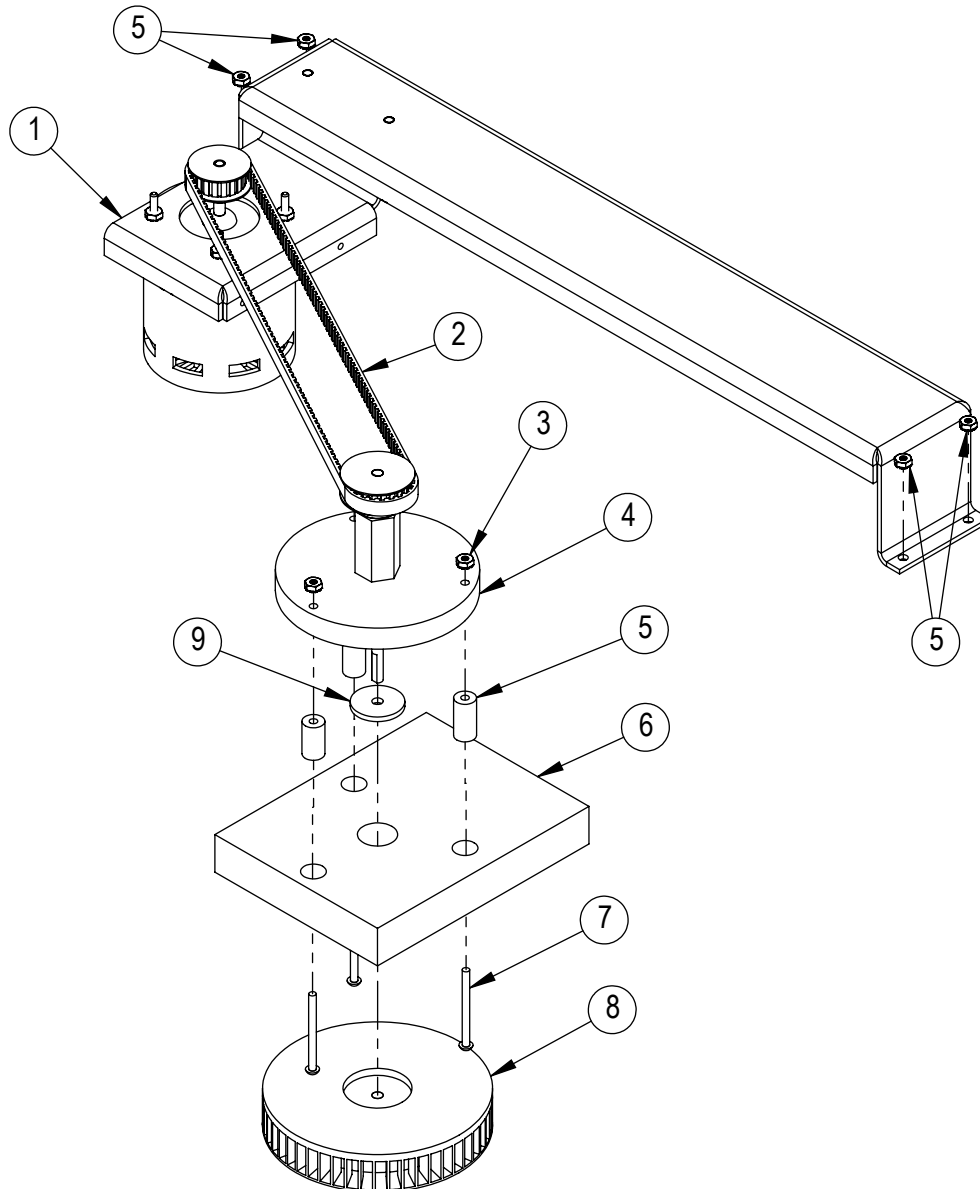

ITEM	PART	DESCRIPTION	QTY
1	14-0043	BLOWER MOTOR ASSY, 240V	1
2	08-1414	BELT DRIVE	1
3	51132	NUT, KEPS, 8-32 ZINC	3
4	92-0609	BLOWER DRIVE SUPPORT	1
5	92-0055	STANDOFF, 1/2 X 1"	3
6	92-0676	INSULATION, STELLAR BLOWER DRIVE	1
7	21343	SCREW, 8-32 X 2, S/S RND HD	3
8	92-0016	WHEEL, BLOWER	1
9	08-4422	GASKET, BLOWER SHAFT	1

# BLOWER MOTOR ASSEMBLY

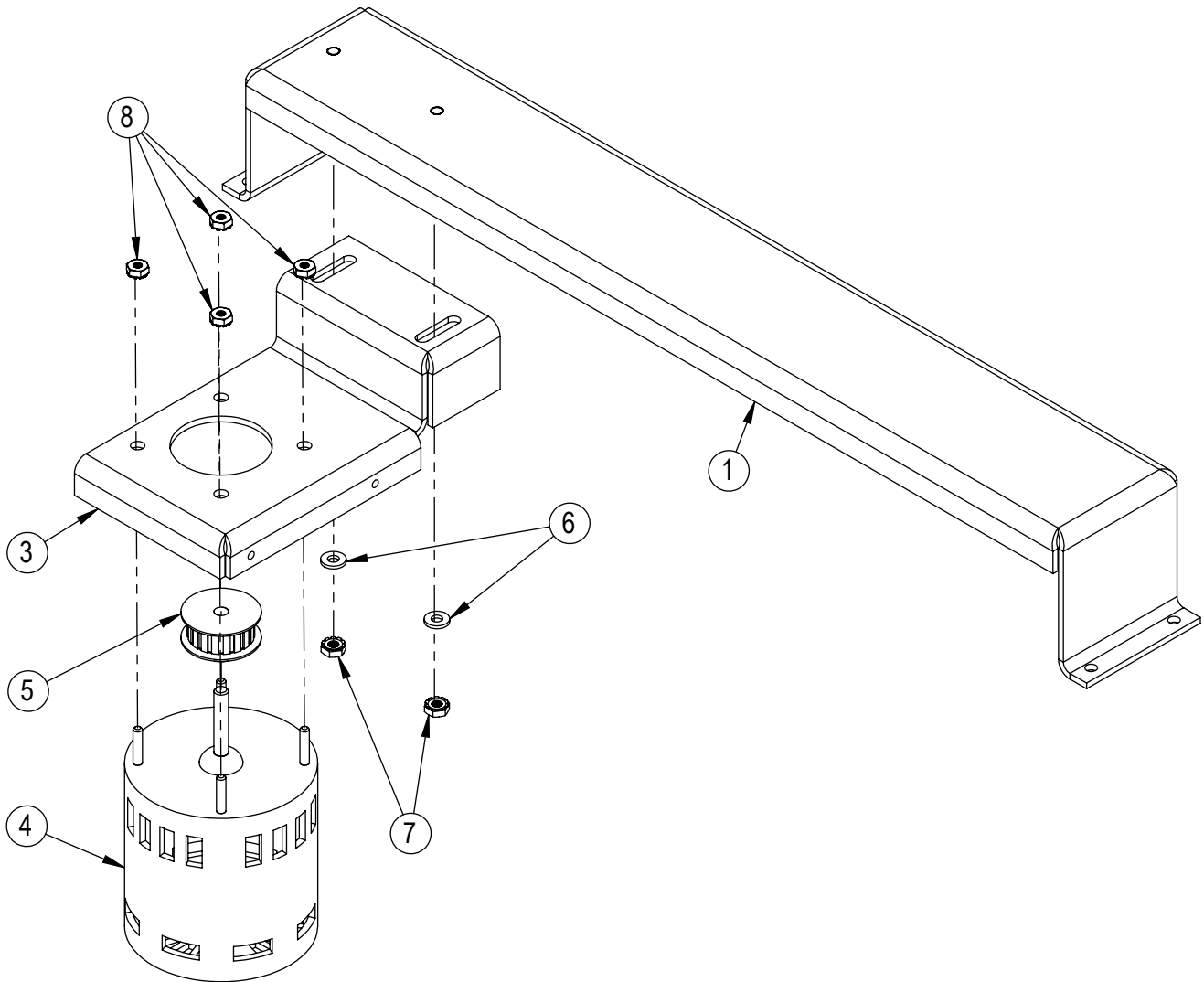

ITEM	PART	DESCRIPTION	QTY
1	92-0678	SUPPORT RAILER, BLOWER MOTOR	1
2	38989	STUD, PRESS, 10-32 x 1/2	2
3	92-0604	BRACKET, MOTOR MOUNT	1
4	08-6905	MOTOR, 1/70 HP, 240V	1
5	08-5600	DRIVE PULLEY	1
6	M1820	WASHER, FLAT, #10	2
7	M9062	NUT, KEPS, 10-32	2
8	51132	NUT, KEPS, #8-32 ZINC	4

# CAVITY PLUMBING COMPONENTS

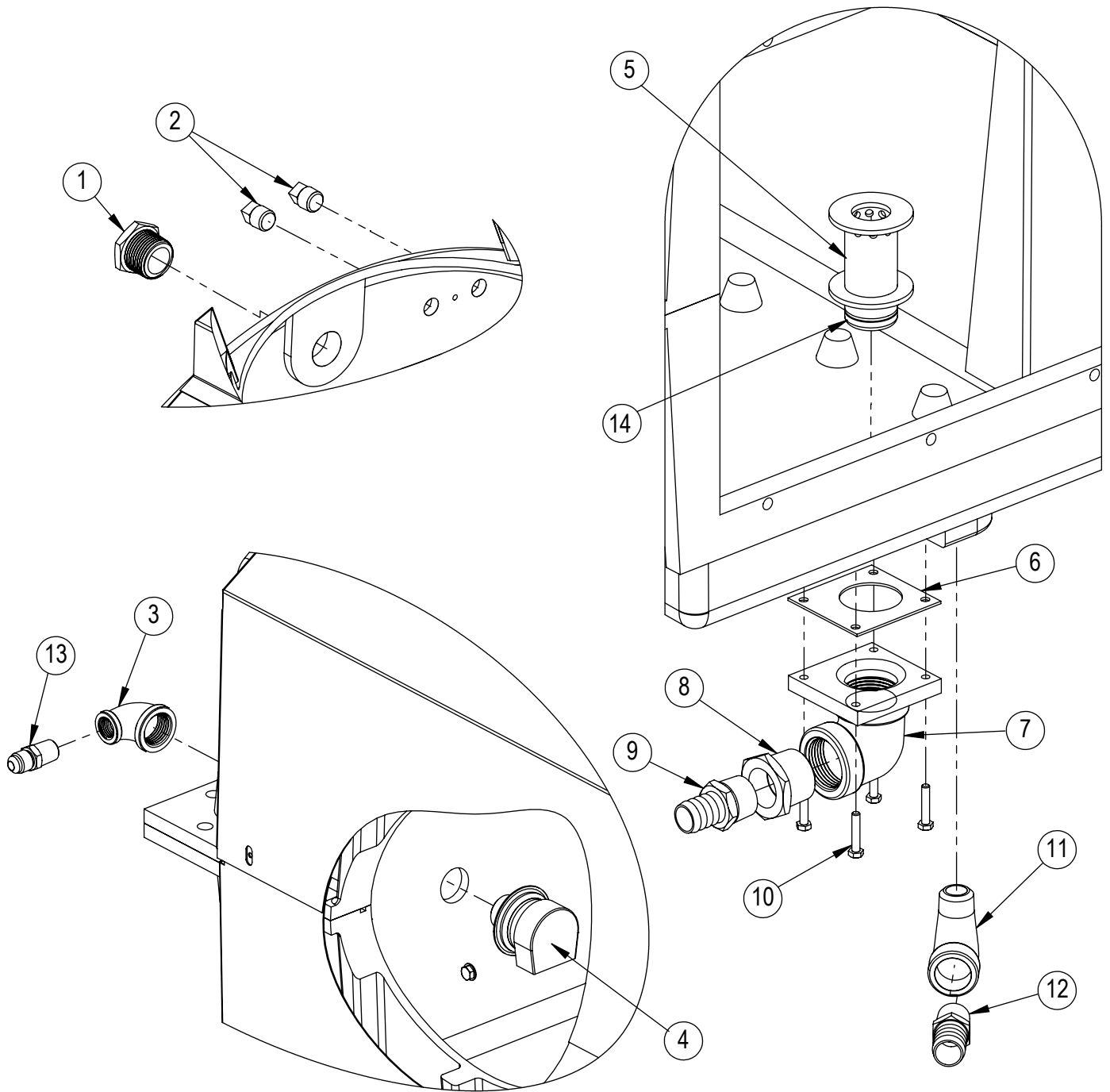

## CAVITY PLUMBING COMPONENTS

ITEM	PART	DESCRIPTION	QTY
1	92-0047	PLUG, 3/4" NPT	1
3	92-0045	REDUCER ELBOW, 1/2" X 1/4" BRONZE	1
4	92-0059	INLET, WATER	1
5	92-0111	PLUG, CAVITY DRAIN	1
6	92-0027	GASKET, CAVITY RESERVOIR	1
7	92-0026	BLOCK, CLEAN RESERVOIR	1
8	92-0110	REDUCER BUSHING, 1" NPT X 3/4" FNPT	1
9	08-4852	FITTING, BRASS, 3/4" NPT X 3/4" BARB	1
10	58109	MACHINE SCREW, 10-32 X 1"	4
11	08-5471	ELBOW, 1/2", STREET	1
12	90-8058	FITTING, BRASS, 1/2" NPT X 3/4" BARB	1
13	08-5474	ADAPTER HOSE, 5/16" TUBE X 1/4" NPT	1
14	92-0631	O-RING, CAVITY DRAIN PLUG	

## DRAIN LINES & HEAT EXCHANGER

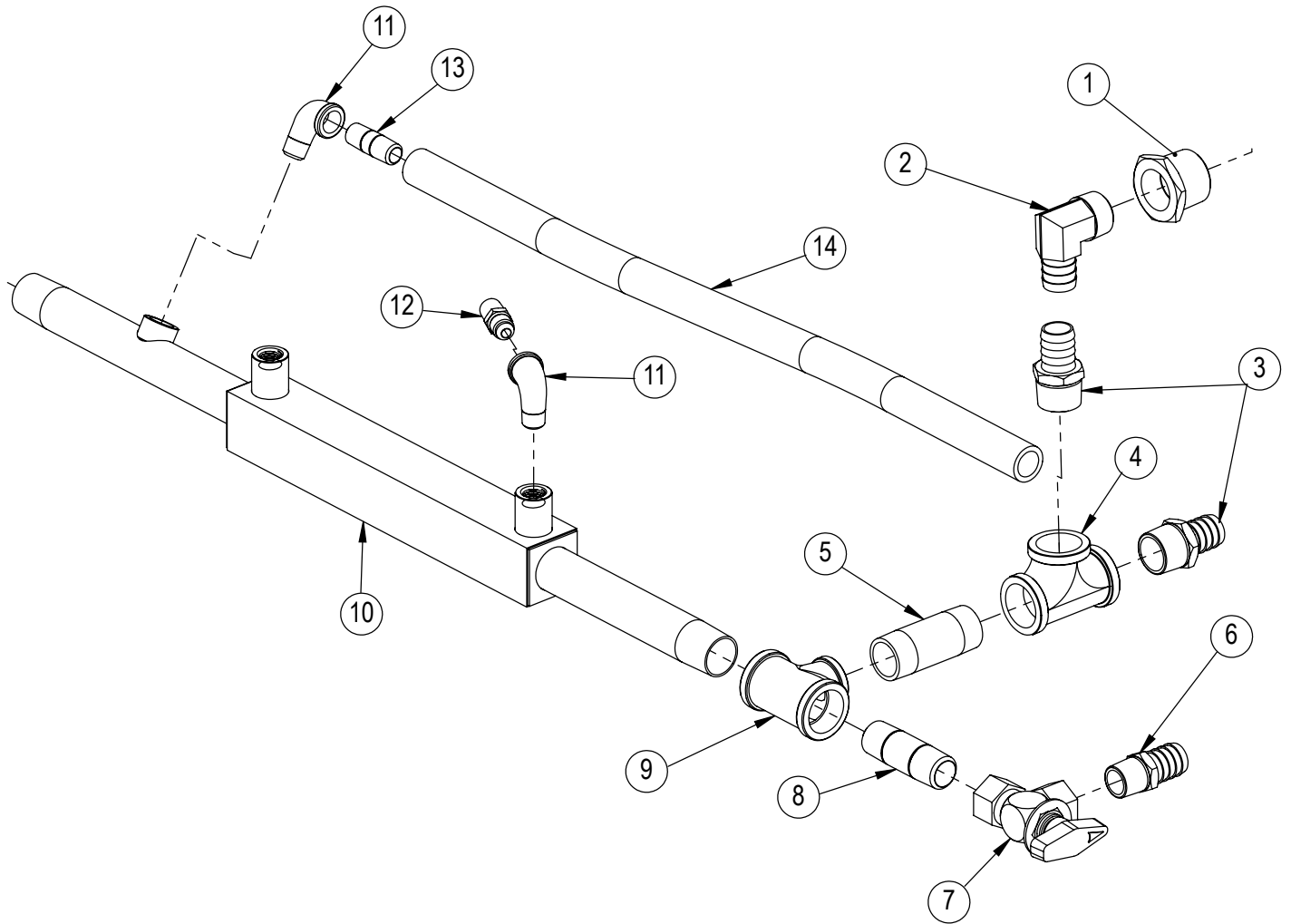

ITEM	PART	DESCRIPTION	QTY
1	<a href="#">92-0110</a>	REDUCER BUSHING, 1" NPT X 3/4" FNPT	1
2	<a href="#">92-0109</a>	ELBOW, 3/4" MNPT X 3/4" BARB	1
3	<a href="#">08-4852</a>	FITTING, BRASS, 3/4" NPT X 3/4" BARB	2
4	<a href="#">08-4990</a>	TEE, BRASS, 3/4"	1
5	<a href="#">08-5427</a>	NIPPLE, 3/4 NPT X 2-1/2"	1
6	<a href="#">90-8058</a>	FITTING, BRASS, 1/2" NPT X 3/4" BARB	1
7	<a href="#">92-0738</a>	DRAIN VALVE, 90° MANUAL	1
8	<a href="#">10-2868</a>	NIPPLE, BRASS, 1/2" NPT X 2-1/2"	1
9	<a href="#">10-8289</a>	REDUCING TEE, 3/4" X 3/4" X 1/2"	1
10	<a href="#">92-0807</a>	HEAT EXCHANGER, DRAIN	1
11	<a href="#">92-0058</a>	ELBOW, STREET, 1/4" NPT	2
12	<a href="#">08-5474</a>	HOSE ADAPTER, 5/16" TUBE X 1/4" NPT	1
13	<a href="#">92-0061</a>	NIPPLE, BRASS, 1/4" NPT X 1-1/2"	1
14	<a href="#">08-7960</a>	HOSE, NEOPRENE, 5/8" I/D X 1/8" WALL	24"

# WATER INLET AND OUTLET

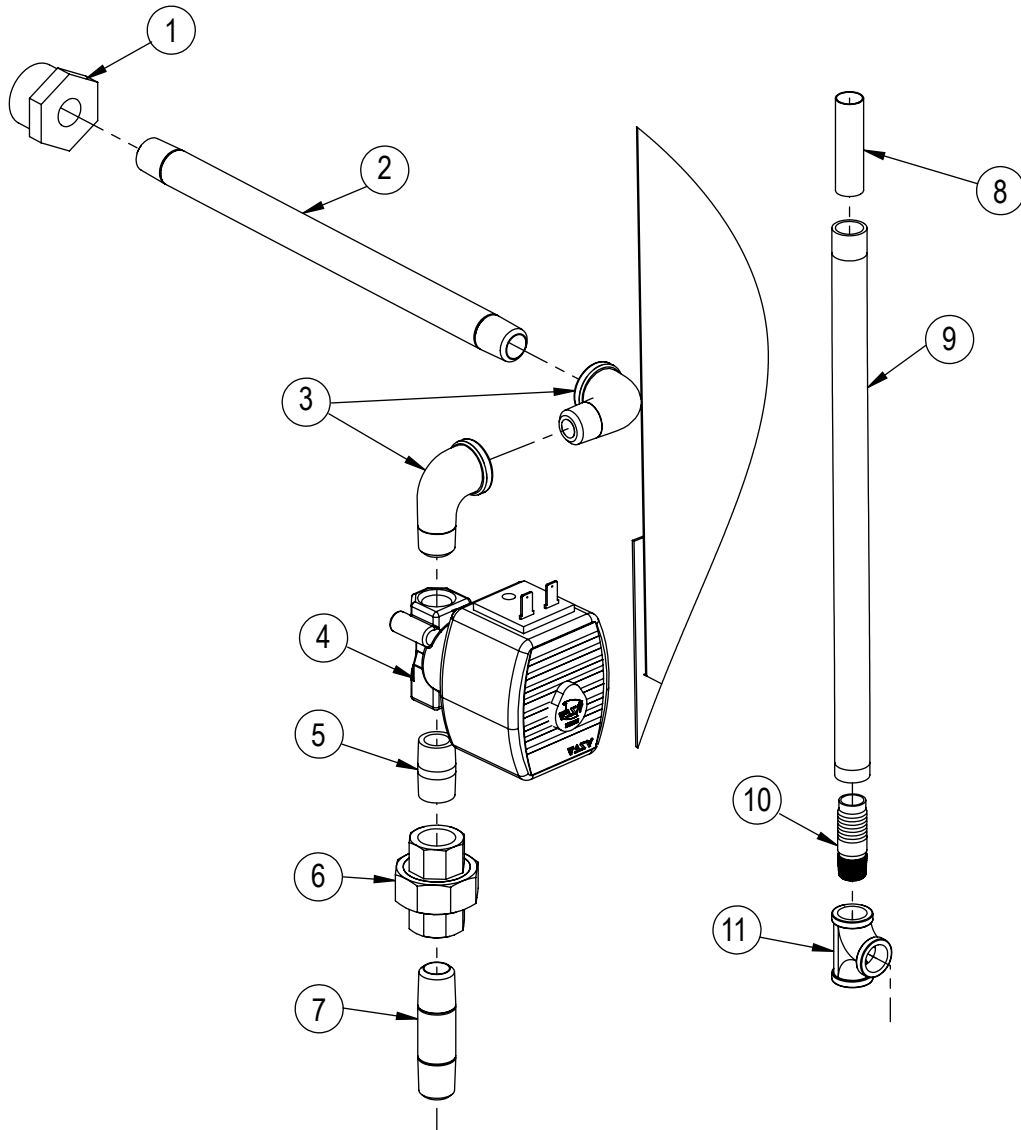

ITEM	PART	DESCRIPTION	QTY
1	92-0060	CONNECTOR, 3/4" GARDEN HOSE	1
2	92-0040	NIPPLE, BRASS, 1/4" NPT X 8"	1
3	92-0058	ELBOW, STREET, 1/4" NPT	2
4	92-0172	SOLENOID VALVE, 120V	1
5	08-5446	NIPPLE, 1/4 NPT, CLOSE	1
6	92-0039	UNION, BRASS, 1/4" NPT	1
7	92-0041	NIPPLE, BRASS, 1/4" NPT X 2"	1
8	92-0028	VENT EXTENSION TUBE	1
9	10-0239	RUBBER HOSE, 1" I.D.	1
10	08-1202	FITTING, HOSE NIPPLE, 3/4 NPT X 1" BARB	1
11	10-2804	TEE, 3/4" BLK	1

# EXTERIOR COMPONENTS

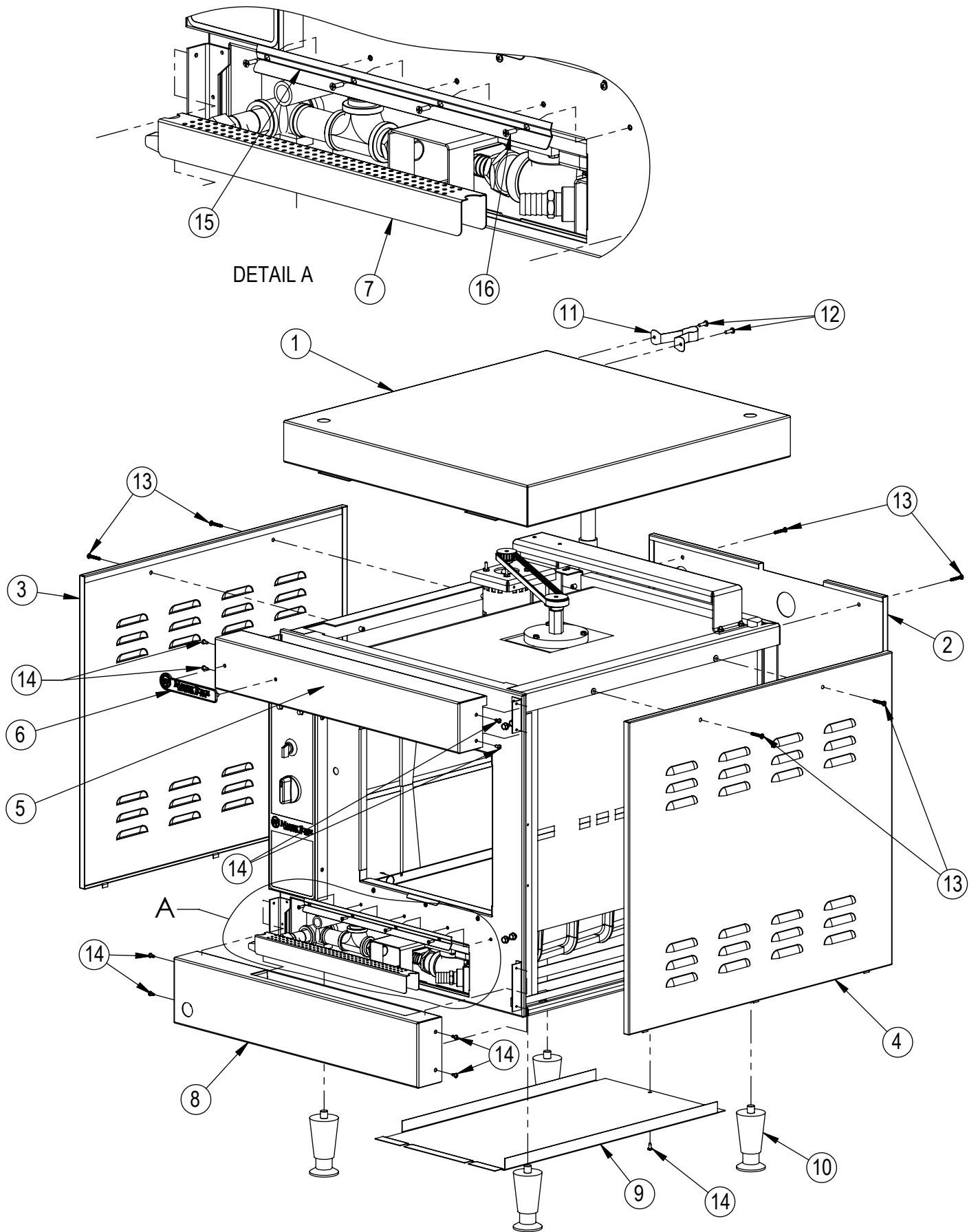

# EXTERIOR COMPONENTS

ITEM	PART	DESCRIPTION	QTY
1	92-0053	BODY TOP (TOP HOUSING)	1
2	92-0008	BACK PANEL, 4 PAN STEAMER	1
	92-0357	BACK PANEL, 6 PAN STEAMER	1
3	92-0727	SIDE PANEL, LH, 4 PAN STEAMER	1
	92-0728	SIDE PANEL, LH, 6 PAN STEAMER	1
4	92-0726	SIDE PANEL, RH, 4 PAN STEAMER	1
	92-0729	SIDE PANEL, RH, 6 PAN STEAMER	1
5	92-0730	FRONT PANEL, TOP SECTION	1
6	08-5894	NAMEPLATE, CAST	1
7	92-0428	TROUGH COVER, DRAIN	1
8	92-0725	FRONT PANEL, BOTTOM SECTION	1
9	92-0379	PANEL, BODY BOTTOM	1
10	08-7520	LEG, PLASTIC, 4"	4
11	92-0700	PIPE HANGER CLAMP	1
12	15247	SCREW, #10-16 X 5/8", SELF DRILL	2
13	R7313	SCREW, #8-32 X 1" S/S	6
14	53761	SCREW, #8-32 X 3/8", THRD CUT	9
15	92-0733	DRIP DIVERTER	1
16	R9260	SCREW, #6-32 X 1/2" S/S	4

# INTERIOR COMPONENTS

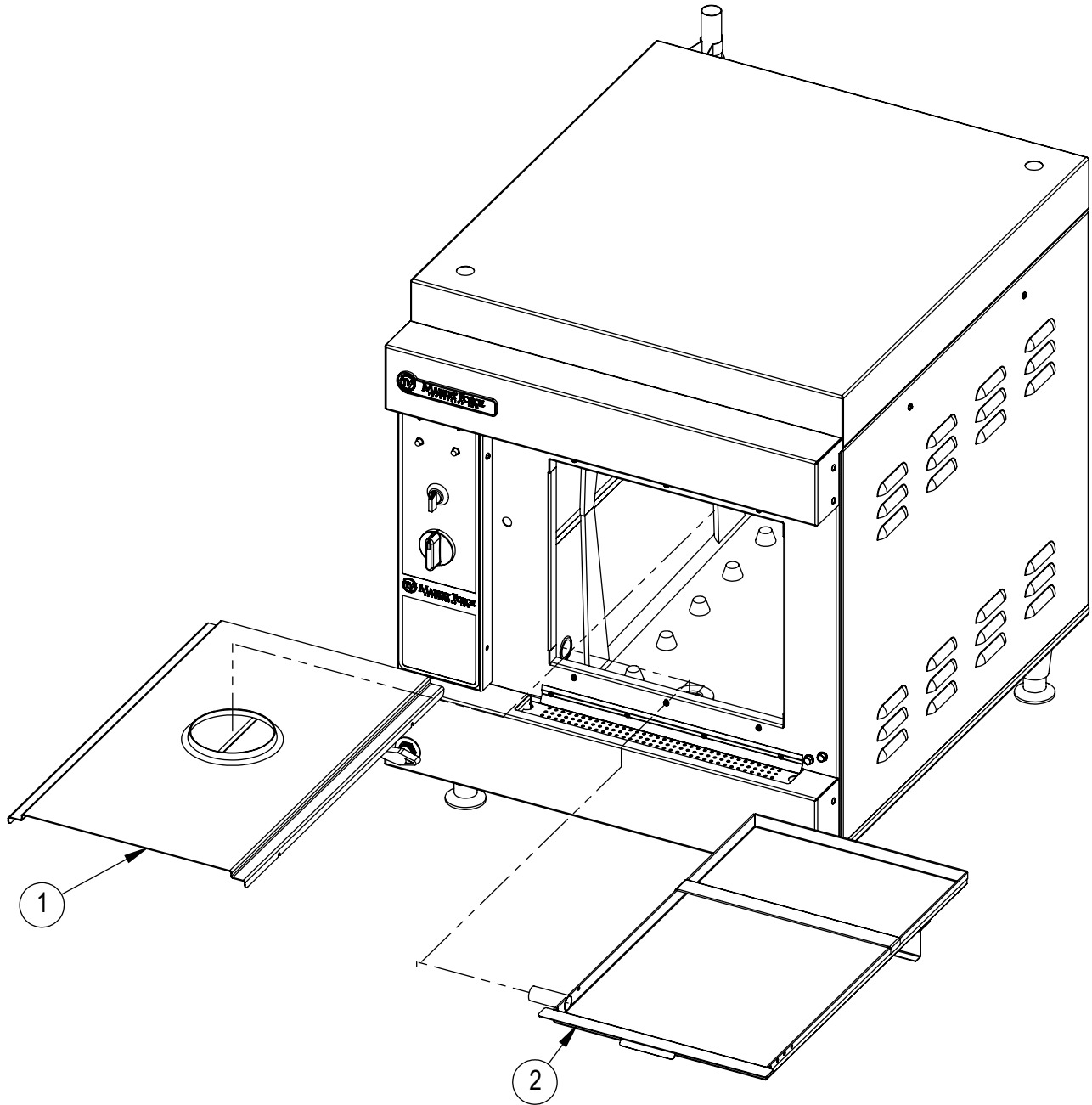

ITEM	PART	DESCRIPTION	QTY
1	92-0011	BAFFLE, FAN	1
2	92-0014	PAN, CLEANUP	1