

N-Fusion™

Nitrogen Beverage Dispensers

Installation, Operation & Maintenance Manual

This manual is updated as new information and models are released. Visit our website for the latest manual.



Original Document

Part Number: 9290312 October/22/2018

Safety Notices

DEFINITIONS

⚠ DANGER

Indicates a hazardous situation that, if not avoided, will result in death or serious injury. This applies to the most extreme situations.

⚠ Warning

Indicates a hazardous situation that, if not avoided, could result in death or serious injury.

⚠ Caution

Indicates a hazardous situation that, if not avoided, could result in minor or moderate injury.

Notice

Indicates information considered important, but not hazard-related (e.g. messages relating to property damage).

NOTE: Indicates useful, extra information about the procedure you are performing.

有害物质						
组件名称	铅	汞	镉	六价铬	多溴联苯	多溴联苯醚
	(Pb)	(Hg)	(Cd)	(Cr (VI))	(PBB)	(PBDE)
机壳	○	○	○	○	○	○
分配系统	X	○	○	○	○	○
电子产品	X	○	○	○	○	○
冰箱系统	X	○	○	○	○	○
打包	○	○	○	○	○	○

Key:

X: 表示该有害物质至少在该部件的某一均质材料中的含量超出 GB / T 26572标准规定的限量要求

○: 表示该有害物质在该部件所有均质材料中的含量均在 GB / T 26572标准规定的限量要求以下



Table of Contents

	Safety Notices	2
	Definitions.....	2
Section 1		
General Information		
	Read This Manual	5
	About N₂ Fusion™	5
	Unit Inspection	5
	Model Numbers	5
	Serial Number Location	5
	Warranty Information	5
	Specifications	6
	Dimensions.....	6
	Capacity & Weight.....	6
	Product Delivery Location.....	7
	Refrigerant Charge.....	7
	Electrical	8
Section 2		
Installation		
	Step-by-Step Installation	11
	Pre-installation Checklist.....	11
	Remote Tower Installation	12
	Nitrogen Regulator & Tank Assembly	13
	Nitrogen Installation/Replacement.....	13
	Nitrogen Connections & Pressures	14
	N ₂ Quick Disconnect & Drain.....	14
	Keg & Pump Regulators	15
	Keg Connections	15
	Plumbing Diagram.....	17
	Door Hinge Reversal.....	18
Section 3		
Operation		
	Machine Operation	19
	Controls/Programming/Settings	19
	Prime / Clean Button	19
	Clearing Error Code	20
	Priming the System	20
	Taps & Nozzles	20
	Keg Change	21
	Nitrogenator	22

**Section 4
Maintenance**

Cleaning & Sanitizing.....23
 General Cleaning..... 24
 Cleaning Supplies 24
 Manual Keg Cleaning..... 25
 Level 1 - Daily Cleaning..... 26
 Level 2 - Weekly Cleaning (Single Step Method) 29
 Level 2 - Weekly Cleaning (Three Step Method) 31
 Level 3 - Monthly Cleaning 34
Other Operations35
 Doors & Hinges 35

**Section 5
Troubleshooting**

Troubleshooting Charts.....37
 Dispensing Issues..... 37
 Refrigerator Cabinet Issues..... 38
 Pouring..... 39

Section 1

General Information

Read This Manual

Manitowoc Foodservice developed this manual as a reference guide for the owner/operator and installer of this equipment. Please read this manual before installation or operation of the machine. A qualified service technician must perform installation and start-up of this equipment. Consult **Section 4** within this manual for service assistance.

If you cannot correct the service problem, consult Manitowoc KitchenCare at 1-844-724-CARE. Always have your model and serial number available when you call.

Your Service Agent _____

Service Agent Telephone Number _____

Your Local Distributor _____

Distributor Telephone Number _____

Model Number _____

Serial Number _____

Installation Date _____

About N₂Fusion™

Class A: EMC Registration is done on this equipment for business use only (Class A). Product seller and user should notice that this equipment is not for household use.

Unit Inspection

Thoroughly inspect the unit upon delivery. Immediately report any damage that occurred during transportation to the delivery carrier. Request a written inspection report from a claims inspector to document any necessary claim. See "Warranty Information" on page 5.

⚠ Warning

Do not damage the refrigeration circuit when installing, maintaining or servicing the unit.

⚠ Warning

Do not operate equipment that has been misused, abused, neglected, damaged, or altered/modified from that of original manufactured specifications.

This appliance is not intended for use by persons (including children) with reduced physical, sensory or mental capabilities, or lack of experience and knowledge, unless they have been given supervision concerning use of the appliance by a person responsible for their safety. Children should be supervised to ensure that they do not play with the appliance.

Model Numbers

This manual covers the following models:

N₂Fusion™ Nitrogen Beverage Dispenser
ND21TS00, ND21TS01, ND21TS02, ND21TS03, ND21TS04, ND21RS00, ND21RS02

Serial Number Location

The serial number on N₂Fusion™ Nitrogen Beverage Dispenser is printed on the left side of the interior wall.

Always have the serial number of your unit available when calling for parts or service.

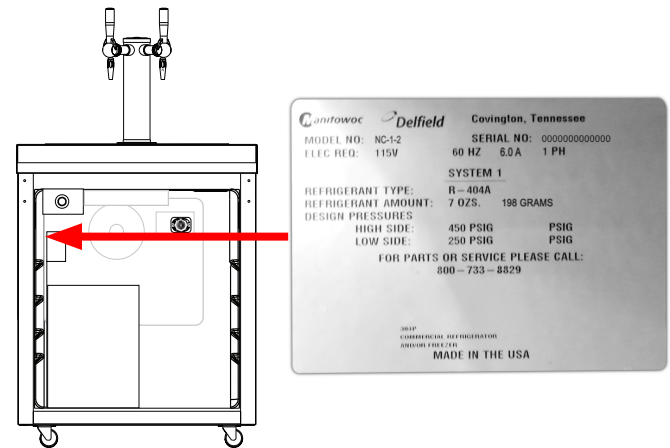

Sample Serial Tag

Warranty Information

Consult your local Service Agent or Representative for terms and conditions of your warranty. Your warranty specifically excludes all general adjustments, cleaning, accessories and related servicing.

Your warranty card must be returned to activate the warranty on this equipment. If a warranty card is not returned, the warranty period can begin when the equipment leaves the factory.

No equipment may be returned without a written Return Materials Authorization (RMA). Equipment returned without an RMA will be refused at the dock and returned to the sender at the sender's expense.

Please contact your local distributor for return procedures

Specifications

DIMENSIONS

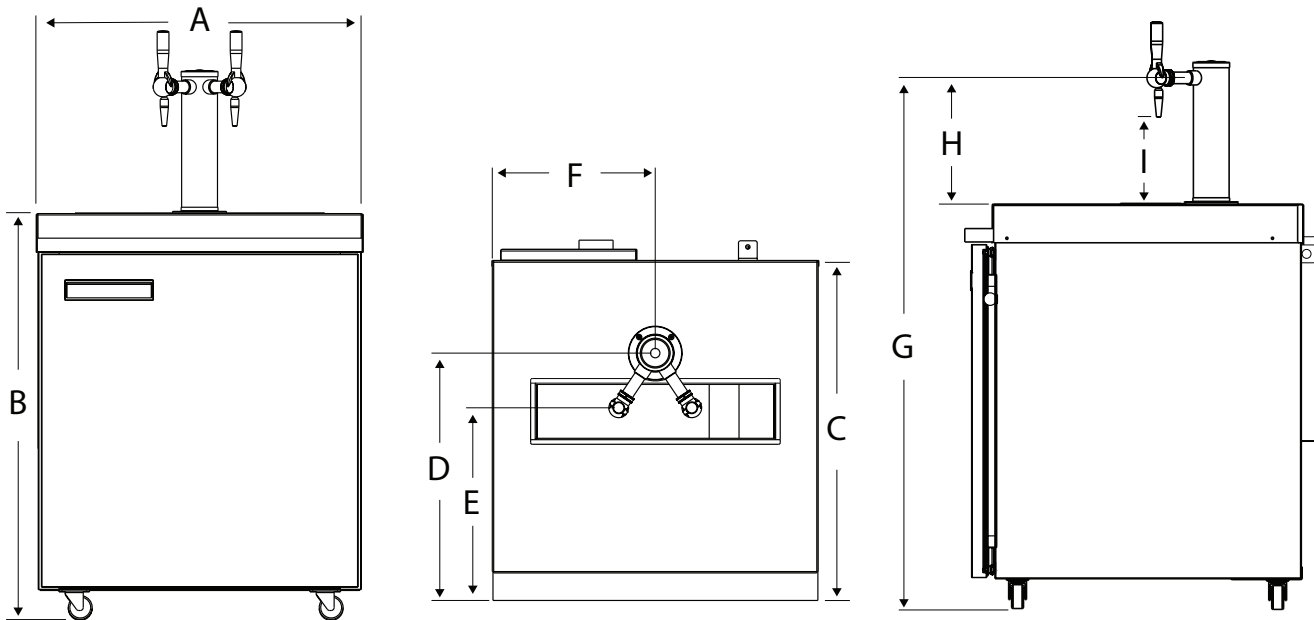

Model	A	B	C	D	E	F	G	H	I
ND21TS00	27.3" (69 cm)	34.0" (86 cm)	28.4" (72 cm)	20.7" (53 cm)	13.6" (35 cm)	16.1" (41 cm)	44.6" (113 cm)	10.6" (27 cm)	7.3" (19 cm)
ND21TS01									
ND21TS02									
ND21TS03									
ND21TS04									
ND21RS00		30.75" (78 cm) *							
ND21RS02									

* This dimension represents units using 1.25" (3.175 cm) low profile casters, regular casters are 1.25" (3.175 cm) taller.

Warning

To avoid instability the installation area must be capable of supporting the weight of the equipment. Additionally the equipment must be level side to side and front to back.

CAPACITY & WEIGHT

Model	Max Capacity	Volume	Weight
ND21TS00	3 - 3 Gallon (11.36L) Coffee Kegs	5.7Ft ³ (161L)	168lbs (76kg)
ND21TS01			
ND21TS02			
ND21TS03			
ND21TS04			
ND21RS00			
ND21RS02			

PRODUCT DELIVERY LOCATION

⚠ Warning
 This equipment must be positioned so that the plug is accessible unless other means for disconnection from the power supply (e.g., circuit breaker or disconnect switch) is provided.

⚠ Warning
 Adequate means must be provided to limit the movement of this appliance without depending on or transmitting stress to the electrical conduit or gas lines.

⚠ Warning
 To avoid instability the installation area must be capable of supporting the combined weight of the equipment and product. Additionally the equipment must be level side to side and front to back.

⚠ Warning
 This equipment is intended for indoor use only. Do not install or operate this equipment in outdoor areas.

⚠ Warning
 Do not position the air intake vent near steam or heat exhaust of another appliance.

The location selected for the equipment must meet the following criteria. If any of these criteria are not met, select another location.

- Units are intended for indoor use only.
- The location MUST be level both front to back and side to side, stable and capable of supporting the weight of the equipment.
- Position the equipment so it will not tip or slide.
- Recommended air temperature is 41° - 86°F (5° - 30°C), and must not exceed 90°F (32°C), climate class 4.
- Location must have proper ventilation, DO NOT install in an enclosure/enclosed cabinet with no access to ambient air.
- The location must not be near heat-generating equipment or in direct sunlight and must be protected from weather.
- Verify floor of install location is within 1/2" (1.3 cm) of level front to back, side to side.
- Keep equipment area clear of combustible material.
- Do not install the equipment directly over a drain. Steam rising up out of the drain will adversely affect operation, air circulation, and damage electrical /electronic components
- Do not install in an area where a high-pressure water jet could be used for cleaning.

Clearances

⚠ DANGER
 Minimum clearance requirements are the same for noncombustible locations as for combustible locations. The flooring under the appliance must be made of a noncombustible material.

⚠ DANGER
 Risk of fire/shock. All minimum clearances must be maintained. Do not obstruct vents or openings..

Sides	0" (0 cm)
Back	3" (76 mm)
Front	30" (76 cm)

⚠ Warning
 Do not obstruct machine vents or openings this includes installing in an enclosed cabinet where the unit will not have access to ambient air.

Heat of Rejection

Model	BTU/hr
ND21TS00	1430 (0.42 kW)
ND21TS01	
ND21TS02	
ND21TS03	
ND21TS04	
ND21RS00	
ND21RS02	

REFRIGERANT CHARGE

Important
 Due to continuous improvements, this information is for reference only. Please refer to the serial number tag to verify.

Model	Type	Refrigerant Charge
ND21TS00	R404A	7.0 oz (198g)
ND21TS01		
ND21TS02		
ND21TS03		
ND21TS04		
ND21RS00		
ND21RS02		

ELECTRICAL

⚠ DANGER

Check all wiring connections, including factory terminals, before operation. Connections can become loose during shipment and installation.

⚠ Warning

If the supply cord is damaged, it must be replaced by a special cord or assembly available from the manufacturer or its service agent.

⚠ Warning

The machine must be wired and grounded in accordance with national and local electrical codes.

Minimum Circuit Ampacity

The minimum circuit ampacity is used to help select the wire size of the electrical supply. (Minimum circuit ampacity is not the N₂Fusion System's running amp load.) The wire size (or gauge) is also dependent upon location, materials used, length of run, etc., it must be determined by a qualified electrician.

Voltage

A dedicated electrical circuit is required, a power cord is provided with all units. Some models are available in different voltages and may be equipped with a different plug.

The following precautions must be observed:

- The equipment must be grounded.
- A separate fuse/circuit breaker must be provided for each unit.
- A qualified electrician must determine proper wire size dependent upon location, materials used and length of run (minimum circuit ampacity can be used to help select the wire size).
- The maximum allowable voltage variation is ±10% of the rated voltage at equipment start-up (when the electrical load is highest).
- Check all green ground screws, cables and wire connections to verify they are tight before start-up.

Minimum Circuit Amperage Chart

Important

Due to continuous improvements, this information is for reference only. Please refer to the serial number tag to verify.

Model	Voltage/Cycle/Phase	Total Amps	HP	Breaker Size (Max)
ND21TS00	115/60/1	6.0 A	1/5	15 A
ND21RS00		2.5 A		
ND21TS01	220/60/1	2.5 A		
ND21RS02		2.5 A		
ND21TS03	100/60/1	6.0 A		
ND21TS04	100/50/1	6.0 A		

Preparing the power cord (International units only)

The following instructions cover the installation of a 220 VAC, 50/60 Hz (international) unit. An appropriate 3-wire power receptacle must be located within 6 ft (1.8 m) of the unit. Unpack the unit from its transportation packaging and visually check for any signs of damage.

NOTE: Only use an approved plug for the country in which the unit is being installed.

Important

The wires in the power cord/mains lead are colored in accordance with the following code:

- Green / Yellow = Ground/Earth
- Blue = Neutral
- Brown = Line/Live

1. Locate a 3-terminal plug. This plug (not furnished with unit) must have a ground-wire-connecting terminal.
2. Locate the loose end of the power cord attached to the unit. All three (3) wires are stripped to 1/2" (1.3 cm) length from the end.
3. Connect all three (3) wires to the plug using the 1/2" (1.3 cm) stripped ends or any other terminal requirements. Different plugs and terminals may require different stripped lengths.
4. Inspect the cord and plug connection for any loose or bare wires.

Grounding Instructions

This appliance must be grounded/earthed. In the event of malfunction or breakdown, grounding provides a path of least resistance for electric current to reduce the risk of electric shock. This appliance is equipped with a cord having an equipment-grounding conductor and a grounding plug. The plug must be plugged into an appropriate outlet that is properly installed and grounded/earthed in accordance with all local codes and ordinances.

Check with a qualified electrician or serviceman if the grounding instructions are not completely understood or if in doubt as to whether the product is properly grounded.

Do not modify the plug provided; if it will not fit the outlet, have the proper outlet installed by a qualified electrician.

Do not use an extension cord or an adapter plug with this equipment.

NOTE: For 220-240 VAC, 50/60 Hz International Units, a ground male plug must be supplied at the installation of the unit.

Warning

When using electric appliances, basic precautions must always be followed, including the following:

- A. Read all the instructions before using the appliance.
- B. To reduce the risk of injury, close supervision is necessary when an appliance is used near children.
- C. Do not contact moving parts.
- D. Only use attachments recommended or sold by the manufacturer.
- E. Do not use outdoors.
- F. For a cord-connected appliance, the following must be included:
 - Do not unplug by pulling on cord. To unplug, grasp the plug, not the cord.
 - Unplug from outlet when not in use and before servicing or cleaning.
 - Do not operate any appliance with a damaged cord or plug, or after the appliance malfunctions or is dropped or damaged in any manner. Contact the nearest authorized service facility for examination, repair, or electrical or mechanical adjustment.
- G. Follow applicable lock out tag out procedures before working on equipment.
- H. Connect to a properly grounded outlet only. See Grounding Instructions.

THIS PAGE INTENTIONALLY LEFT BLANK

Section 2 Installation

Step-by-Step Installation

These instructions are provided to assist the qualified installer. Contact your Manitowoc Foodservice Service Agent or call Manitowoc Foodservice for information regarding start-up services.

⚠ DANGER

Use appropriate safety equipment during installation and servicing.

⚠ DANGER

Installation must comply with all applicable fire and health codes in your jurisdiction.

⚠ Warning

Remove all removable panels before lifting and installing.

⚠ Warning

Do not damage the refrigeration circuit when installing, maintaining or servicing the unit.

Important

All plumbing must conform to local, state and national codes.

Important

Failure to follow these installation guidelines may affect warranty coverage.

PRE-INSTALLATION CHECKLIST

- Any damage should be noted and reported to the delivering carrier immediately.
- Check the lower portion of the unit to be sure casters are not bent.
- Visually inspect the refrigeration package, compressor compartment housing. Be sure lines are secure and base is still intact.
- Inspect installation location behind the unit for electrical outlet location and Nitrogen (N₂).
- Power unit up by plugging into power source.
- Check for correct voltage at outlet dedicated for the Nitrogen Beverage Dispenser.
- Verify floor of install location is within 1/2" (1.3 cm) of level front to back, side to side and all casters are touching the floor.

⚠ Warning

The mass of this appliance will allow it to move uncontrolled on an inclined surface. Adequate means must be provided to prevent uncontrolled movement at all times.

- Check that internal connections are secure and did not vibrate loose during shipment.
- Installation location has proper ventilation where unit has access to ambient air.

REMOTE TOWER INSTALLATION

These instructions are only for units that require remote placement of the dispensing tower. If this is a self contained unit with out remote setup continue to "Nitrogen Regulator & Tank Assembly" on page 13.

Checklist

- Tower location should be no more than 20.70" (53 cm) from edge of the counter.
- Mount tower within 6 linear ft (1.83 m) from side of base cabinet.
- Make sure location has space for the drip tray shipped with the unit.

NOTE: Drip trays equipped with a drain are also available but are not standard equipment.

Location

1. Identify the counter top location for the tower making sure there is room for the drip tray, conduit routing under the counter, and is away from any heat source.

Important

If the drip tray is equipped with a drain make sure install location is near a floor drain.

2. Using the provided counter top template mark where the 2" (5 cm) conduit and tower mount screw holes will be drilled.

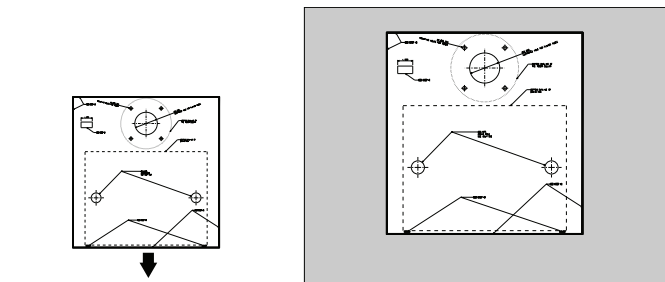

3. Cut and drill holes in the counter using the markings.

NOTE: Drip trays equipped with a drain will need a 7/8" (2.22 cm) hole drilled into the counter using the provided template for routing to a floor drain.

Mounting & Routing

Important

Make sure the rubber counter top gasket is in place on the tower before routing conduit and mounting tower.

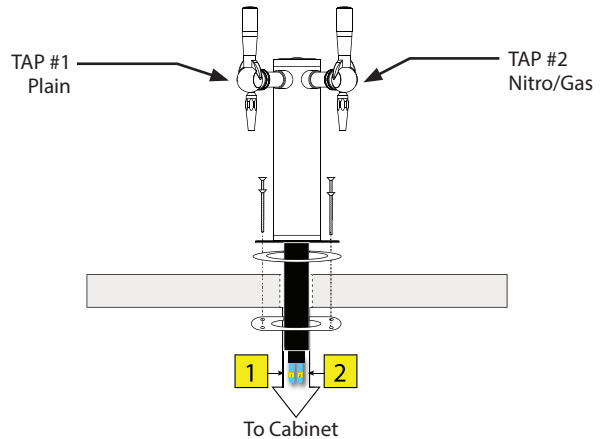

4. Route conduit from the tower down through the 2in (5 cm) hole and mount the tower to the counter top with the provided plate and screws.

NOTE: Make sure the rubber gasket is properly seated on the tower and seals to the counter top.

5. Run the conduit from the tower to the N₂Fusion™ cabinet.
6. Remove the two (2) screws from the solenoid cover mounted to the inside top of the cabinet to gain access to solenoids 1 and 2.

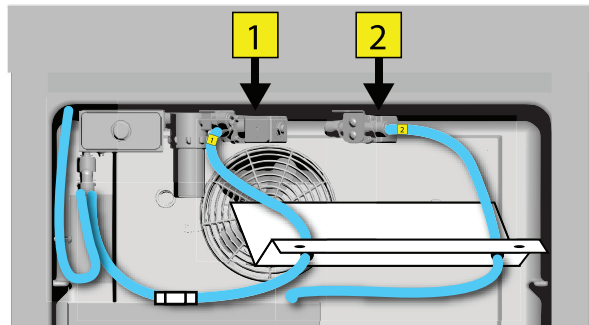

7. Route tubing through the top of the cabinet and attach to the corresponding solenoids.

NOTE: Tubing already routed to the solenoids in the cabinet should be marked with yellow 1 & 2 stickers.

Warning

Do not add line to the conduit this can cause poor drink quality and the unit may not perform properly.

Important

Allow four (4)ft (1.22m) of tubing for a service loop to allow the cabinet to be pulled out during service and cleaning. Cut off extra tubing if needed.

- Once connections have been made put the solenoid cover back into place.

Drip tray

- Place drip tray or drain pan in proper location lined up below the dispensing taps.

Important

Drip trays equipped with a drain need to be sealed to the counter top, be sure to follow all local codes.

NITROGEN REGULATOR & TANK ASSEMBLY**⚠ DANGER**

Tank under high pressure. Do not drop or allow tank to fall over. Tank must be chained and secured to prevent movement as per OSHA requirements. Do not attempt to handle or connect to tank unless properly trained.

NITROGEN IS AN ASPHYXIANT GAS. A LEAK IN AN ENCLOSED AREA COULD DISPLACE OXYGEN AND CAUSE ASPHYXIATION. ALWAYS TEST GAS HANDLING SYSTEMS FOR LEAKS. A N₂ GAS DETECTOR IS RECOMMENDED.

Nitrogen cylinders contain high-pressure gas which can be hazardous if not handled properly. Make sure you READ and UNDERSTAND the following procedures for nitrogen cylinders BEFORE installation.

Important

Use only food grade nitrogen (99.5% pure).

- ALWAYS connect the nitrogen cylinder to the primary regulator and NEVER directly to the unit, keg, or dispensing system. Failure to do so could result in an explosion with possible death or injury when the cylinder valve is opened.
- ALWAYS follow correct procedures when cylinders are changed.
- ALWAYS secure the cylinder in an upright position with a chain.
- NEVER drop or throw a nitrogen cylinder.
- ALWAYS keep a nitrogen cylinder away from heat. Store extra cylinders in a cool place (preferably 70°F). Securely fasten with a chain in an upright position when storing.

- ALWAYS check the D.O.T. test date on the cylinder neck before installation. Ask your gas supplier for D.O.T. test requirements.
- NEVER connect a product container unless there is a safety in the pressure system at or on the nitrogen regulator.

NITROGEN INSTALLATION/REPLACEMENT

NOTE: During initial installation of the unit a bracket for the nitrogen cylinder must be installed to solid wall nearby and a chain used to secure it to the bracket.

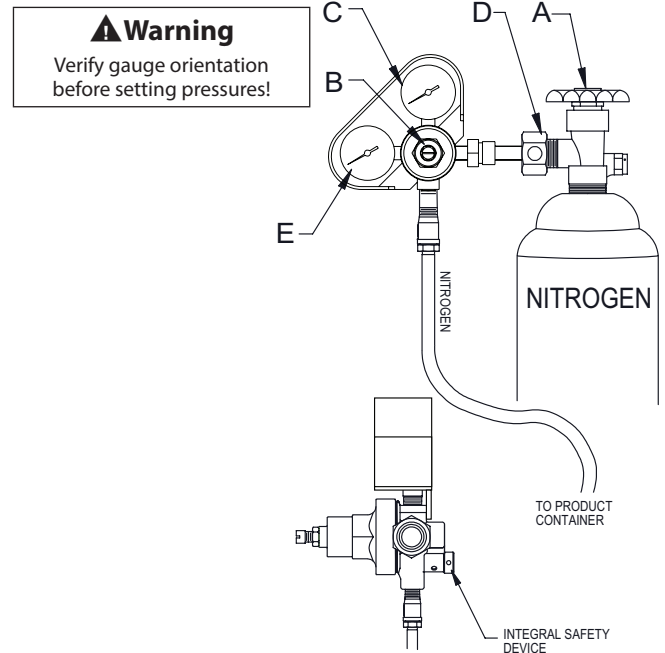

- Make sure cylinder valve "A" is closed.
- Unscrew (counter clockwise) regulator key "B" as far out as it will go. (The regulator is now in the off position.)
- Remove regulator from empty cylinder at "D".
- Remove dust cap from new cylinder at "D". Open and close valve "A" quickly to blow dust from outlet.
- With cylinder valve "A" in closed position, re-attach regulator to cylinder at "D".
- Open valve "A" all the way. (This is important because this cylinder valve seals in two places.)
- Screw regulator key "B" in (clockwise) until required pressure is reached "E".

NOTE: Drinks will not pour if outlet valve "A" is closed.

NITROGEN CONNECTIONS & PRESSURES

1. Set inlet from food grade nitrogen tank to back of the dispenser to 85 - 90 psi (.586 - .621 MPa, 586 - 621 kPa, 5.86 - 6.21 bar).

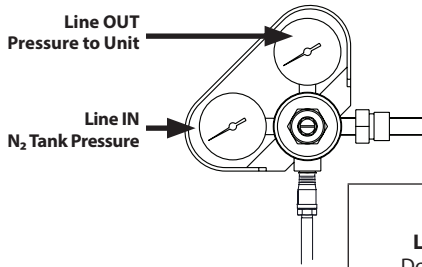

⚠ Warning
Line Out Pressure
 Do Not exceed 90 psi
 (.621 MPa, 621 kPa, 6.21 bar)
 to the unit!

N₂ QUICK DISCONNECT & DRAIN

⚠ Caution
 Installer should always check the locking collars on the taps are tight prior to connecting the Nitrogen supply line. If these collars are loose they can leak at the tower shank when pressurized.

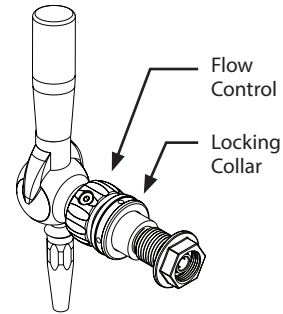

Important
 All plumbing must conform to local, state and national codes.

2. Hook up nitrogen supply line to quick disconnect.
3. Run drip pan drain line and purge tube to floor drain.

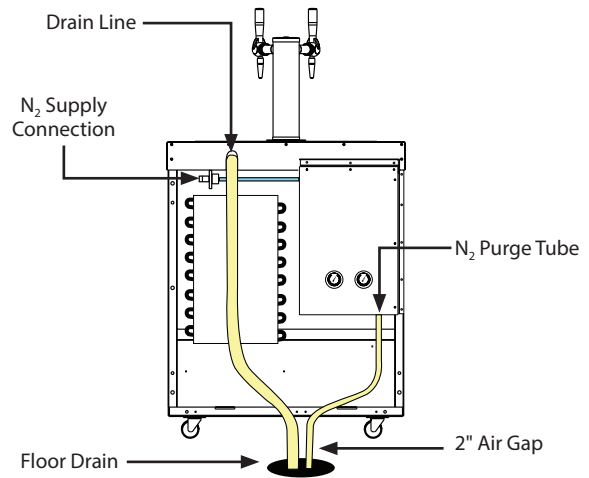

NOTE: Purge tube releases under pressure, make sure it is fastened down.

4. Ensure drain line is not kinked or otherwise blocked for proper drainage.

KEG & PUMP REGULATORS

- Once the nitrogen line is hooked up to the unit check the pressures on the two (2) regulators located in the back of the unit.

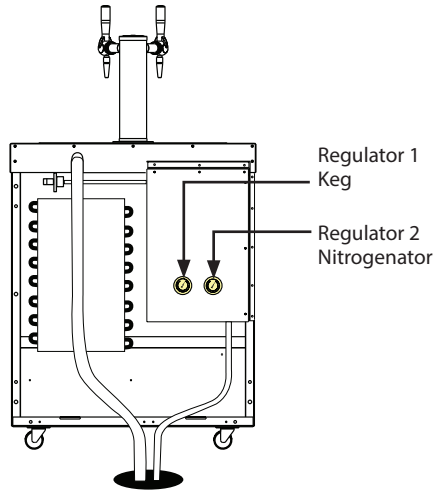

For 60Hz machines

- Verify or set Regulator 1- Nitrogen Supply to Coffee Keg.
 - Set to 16 psi +/- 2 psi (.110 MPa, 110 kPa, 1.10 bar).
- Verify or set Regulator 2- Nitrogen Supply to Nitrogenator.
 - Set to 34 psi +/- 2 psi (.234 MPa, 234 kPa, 2.34 bar).

For 50Hz machines

- Verify or set Regulator 1- Nitrogen Supply to Coffee Keg.
 - Set to 22 psi +/- 2 psi (.152 MPa, 152 kPa, 1.52 bar).
- Verify or set Regulator 2- Nitrogen Supply to Nitrogenator.
 - Set to 44 psi +/- 2 psi (.303 MPa, 303 kPa, 3.03 bar).

If adjustments are needed the installer or technician will need to remove the rear cover to access the regulators.

⚠ DANGER

ELECTRICAL SHOCK HAZARD! The power supply is located in the upper right behind the cover and has live heat sinks. Unplug from power source when removing cover.

KEG CONNECTIONS

⚠ DANGER

Never stand directly over keg when connecting, disconnecting, or when keg is pressurized.

Important

Only use AEB Kegs. Available from Manitowoc FoodService.

Keg Post Collars

- Locate post collars and match the black to OUT post and gray to IN post.

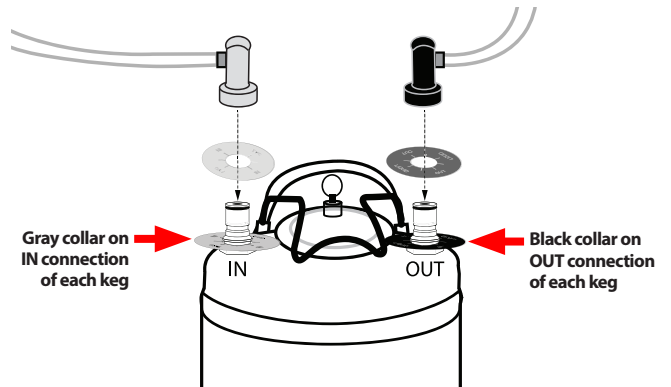

NOTE: Color coding allows partners to match the black connector to black collar and gray connector to gray collar.

- Press each collar over the IN and OUT posts until they seat in the groove below the taper.

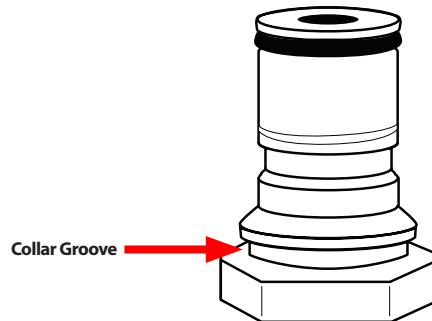

Connecting the Keg

⚠ DANGER
 Never stand directly over keg when connecting, disconnecting, or when keg is pressurized.

Important
 Only use AEB Kegs. Available from Manitowoc Foodservice.

3. First connect the Black quick connect line to the connection labeled OUT on the coffee keg. This supplies coffee to Tap 1 and 2.

Important
 Hook the OUT line up to the coffee keg first, this helps prime the system once the nitrogen IN line is connected to the tank.

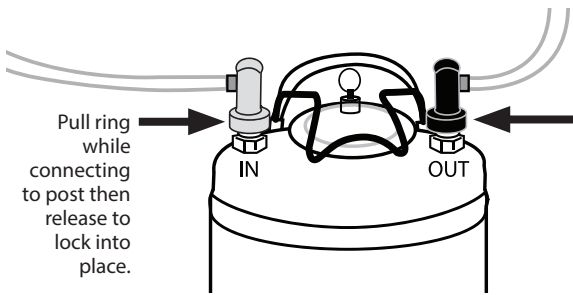

4. Connect the Gray quick connect line second to the connection labeled IN on the coffee keg. This line supplies Nitrogen into tank. See "Keg Change" on page 21 & "Priming the System" on page 20
5. The system is now ready to be primed.
6. Press the Prime/Clean button, located in the upper left corner of the refrigeration cabinet, once to prime the coffee line. The LED around the button will flash ON once, then OFF signifying that the Prime function has been activated.

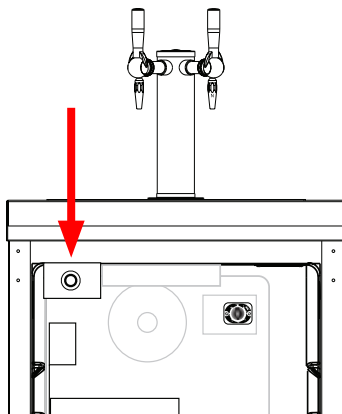

7. The pump may run for up to twenty (20) seconds while priming.

NOTE: If priming fails to complete the system will go into an error state and the Prime/Clean button LED will blink continuously until the error is cleared. See "Clearing Error Code" on page 20

8. Once the system is primed it is ready to pour drinks.
9. Check the regulators to make sure the pressures have not changed and pour a few drinks from each tap to verify proper flow. Adjust pressures if needed.
10. Check for leaks inside the cabinet and at the taps.
11. Close cabinet door and unit is ready for use.

PLUMBING DIAGRAM

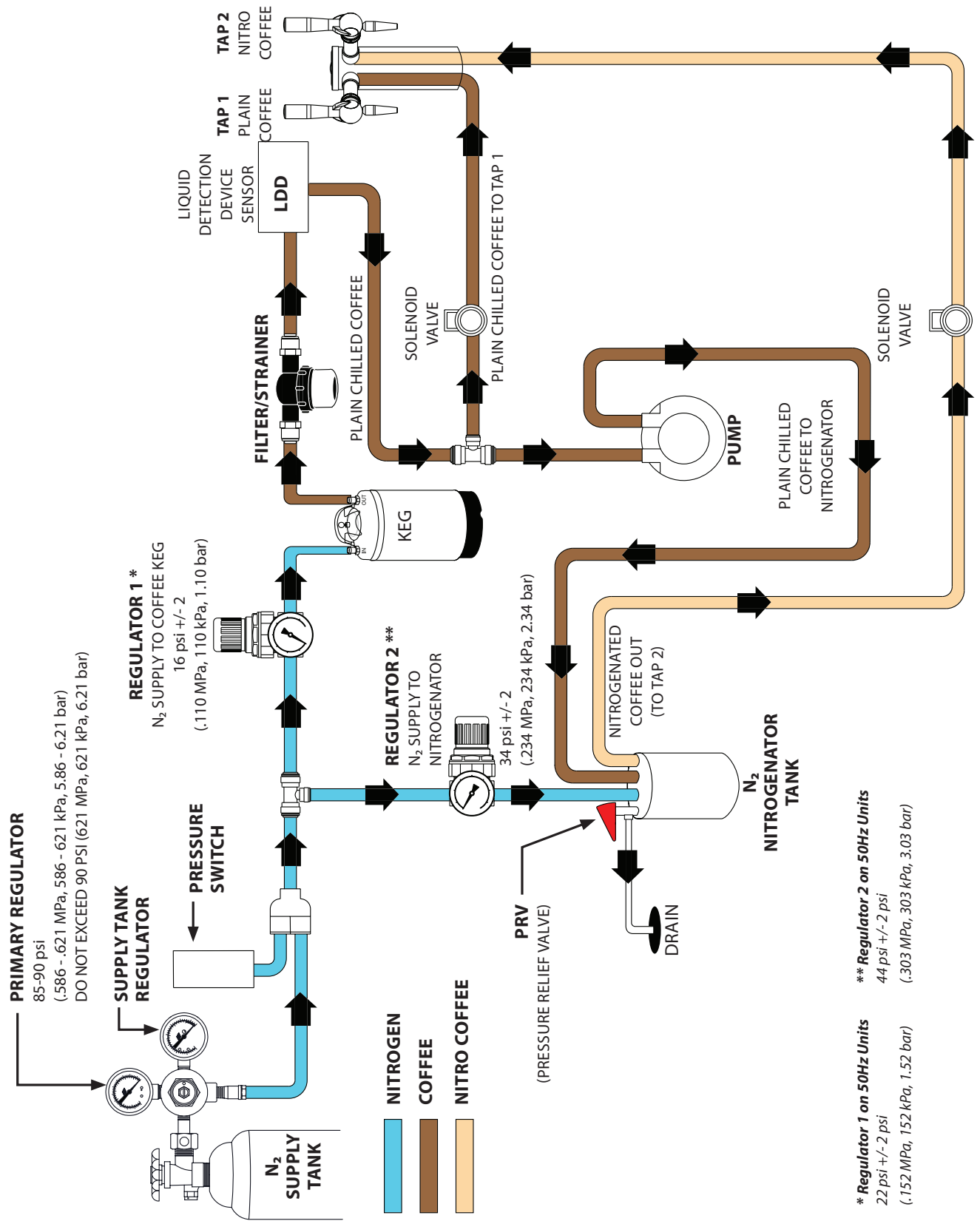

DOOR HINGE REVERSAL

Instructions for installations that require the cabinet door to be reversed.

1. Use a [screwdriver](#) to remove the bottom hinge pin.

NOTE: Lock-tight was used during factory installation, so extra force may be required.

2. Tilt door out from bottom and slide top pin out of the hinge bracket.
3. Remove top hinge pin from door.
4. Use a putty knife or similar tool to remove both plugs from door to expose alternate hinge pin locations and re-install the plugs in original hinge pin locations.
5. Install top hinge pin on new hinge side.
6. Remove top and bottom hinge brackets from cabinet face.
7. Locate etch marks on the opposite side of cabinet face and drill 1/8" (0.3175 cm) holes.

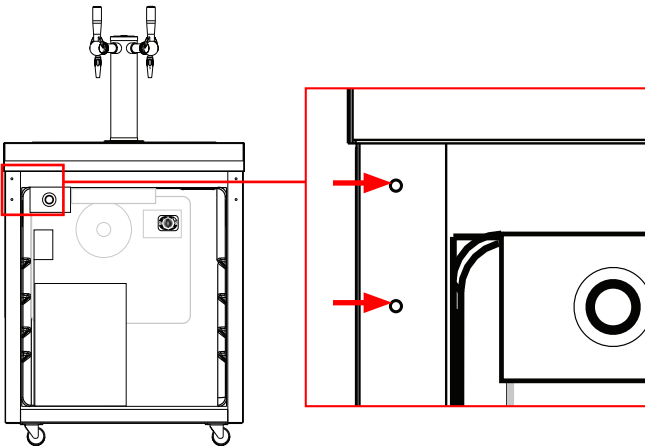

8. Install top and bottom hinge brackets in new locations.
9. Slide top door hinge pin into top hinge bracket and close door onto cabinet face.
10. Install bottom hinge pin through hinge bracket and into door.

Section 3 Operation

Machine Operation

CONTROLS/PROGRAMMING/SETTINGS

After the unit is connected to power it will automatically begin operating. With the doors closed, the temperature of the cabinet should reach 36°F to 40°F (2°C to 4°C) in about one hour.

A thermostat located in the evaporator housing on interior rear of the unit, controls the temperature in the unit. The factory setting for the control is 4 and maintains about 38°F (3°C) in the box. Set toward 1 for higher temperatures and toward 7 for lower temperatures.

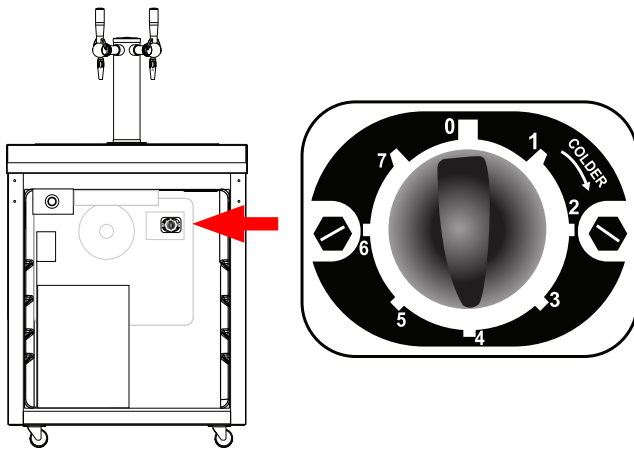

Refrigerators defrost automatically with every cycle of the compressor. The water generated is routed to a pan on the rear of the unit and is evaporated by the heat given off by the compressor.

NOTE: During normal operation the evaporator fan may cycle and/or pulse independently of the compressor.

PRIME / CLEAN BUTTON

The Prime/Clean button is located in the upper left corner of the refrigeration cabinet. This button is used for priming the system with coffee, cleaning, and displaying error codes using the blue LED ring around the button.

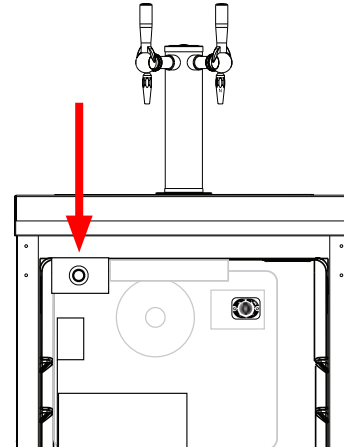

The following table lists the Prime/Clean Button functions and state the LED is in during each mode.

PRIME /CLEAN BUTTON FUNCTIONS	
Mode	LED
Dispense and/or Keg Change	OFF
Prime	Blinks once then OFF when button is pressed
Cleaning	ON constant after button pressed and held
Error	Blinks constantly

NOTE: Error mode can be caused by the following;

- A. Keg Needs Primed or Failed to Prime
- B. Keg is Empty

Important

DO NOT put unit into cleaning mode with coffee keg connected! This empty the keg and pump coffee down the drain!

NOTE: If cleaning mode is accidentally entered with a coffee keg attached immediately press and hold the Prime/Clean button until the LED turns OFF. Priming may be required to put the unit back into dispense mode.

CLEARING ERROR CODE

Important

Prime/Clean button LED will blink continuously and unit will not dispense until the error is cleared.

To clear the error;

1. Press and hold the Prime/Clean button until the LED around the button turns OFF.
2. Once the error has been cleared, press and release the Prime/Clean button again to prime the unit.

PRIMING THE SYSTEM

Important

Priming is always required during keg change.

1. Press the Prime/Clean button, located in the upper left corner of the refrigeration cabinet, once to prime the coffee line. The LED around the button will flash ON once, then OFF signifying that the Prime function has been activated.

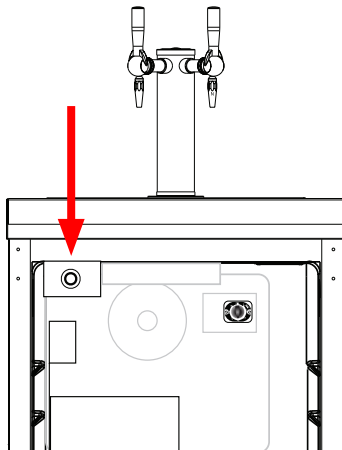

2. The pump may run for up to twenty (20) seconds while priming.

Important

If priming fails to complete the system will go into an error state and the Prime/Clean button LED will blink continuously until the error is cleared.

NOTE: If error occurs See "Clearing Error Code" on page 20

3. Once the system is primed it is ready to pour drinks.
4. Close cabinet door and unit is ready for use.

TAPS & NOZZLES

For best performance do not allow both taps to remain fully opened for extended periods of time.

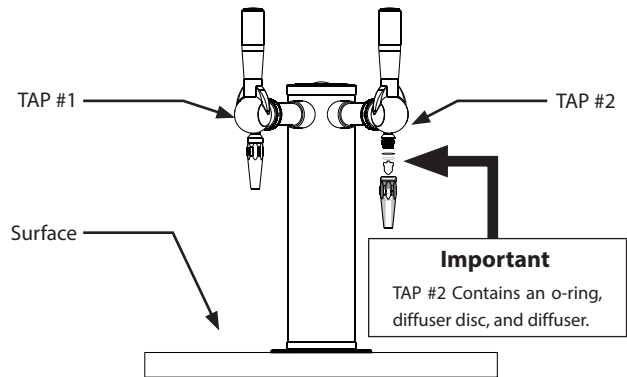

- Tap 1 - Regular Coffee
- Tap 2 - Nitrogenated Coffee

Important

Coffee on tap 2 will not be nitrogenated properly if the correct nozzle with diffuser is not installed.

"How to Remove Nozzles" on page 26 & "How to Install Nozzles" on page 26

Flow Control & Locking Collar

DO NOT adjust the flow control, it is set at the factory. The locking collar keeps the tap tightened to the tower. A special tool is required for proper adjustment.

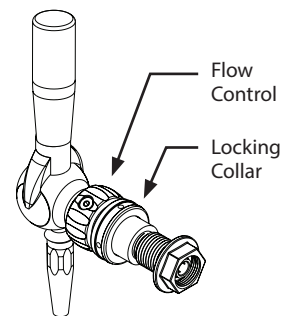

KEGS

Important
 Only use AEB Kegs. Available from Manitowoc FoodService.

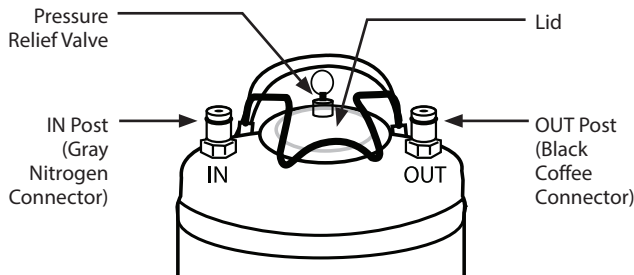

Warning
 Do not attempt to remove lid until all pressure has been relieved from keg.

KEG CHANGE

When a coffee keg is empty product will no longer dispense.

Important
 Make sure new coffee keg has been chilled to the operating temperature range of 45° - 36°F (7° - 2°C) before use or may cause foaming in the system.

DANGER
 Never stand directly over keg when connecting, disconnecting, or when keg is pressurized.

1. Disconnect the GAS IN (gray) fitting from the keg by pulling up on the ring around the connector to release from the post.

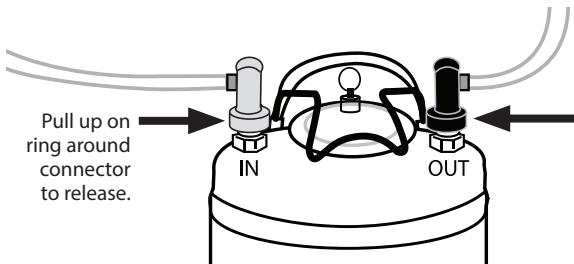

2. Leave the COFFEE OUT (black) fitting connected to the keg.

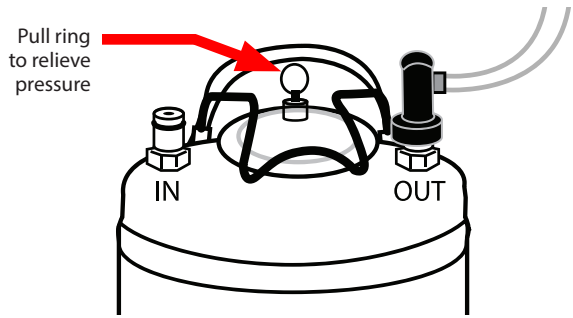

3. Pull up on the pressure relief ring on top of the keg (illustrated above) to vent the nitrogen from the keg and the system plumbing shown above.

NOTE: Hold the ring up until the system is fully vented (hissing gas stops).

4. Disconnect the COFFEE OUT (black) fitting from the keg and remove the keg.
5. Place new keg in cabinet
6. Connect the COFFEE OUT (black) fitting to the keg first then connect the GAS IN (gray) fitting.
7. Prime system by pressing the Prime/Clean button. See "Priming the System" on page 20
8. Pour a drink out of each tap to see if beverage comes out, if not See "Troubleshooting Charts" on page 37.

NITROGENATOR

Nitrogen tank is equipped with a pressure relief valve that will automatically purge when pressure exceeds operating limit of the system of 100 psi (.689 MPa, 689 kPa, 6.89 bar). When valve relieves there may be a quick pressure relief sound heard coming from cabinet. Relief sound shouldn't last more than a few seconds and may not be noticeable on an audible level.

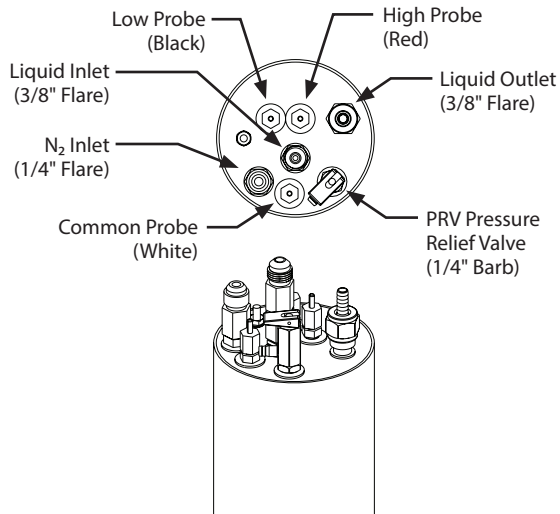

Section 4 Maintenance

Cleaning & Sanitizing

NOTE: Cleaning items, other than the nozzle cleaning hoses, are not supplied with the N₂Fusion™ Nitrogen Beverage Dispenser.

⚠ DANGER

It is the responsibility of the equipment owner to perform a Personal Protective Equipment Hazard Assessment to ensure adequate protection during maintenance procedures.

⚠ DANGER

Failure to disconnect the power at the main power supply disconnect could result in serious injury or death. The power switch DOES NOT disconnect all incoming power.

⚠ DANGER

Disconnect electric power at the main power disconnect for all equipment being serviced. Observe correct polarity of incoming line voltage. Incorrect polarity can lead to erratic operation.

Important

When cleaning interior and exterior of unit, care should be taken to avoid electrical components and wiring. Keep water and/or cleaning solutions away from these parts.

⚠ Warning

Do not damage the refrigeration circuit when installing, maintaining or servicing the unit.

⚠ Warning

Never Use Steel Pads, Wire Brushes or Scrapers!

Important

Never use a high-pressure water jet for cleaning or hose down or flood interior or exterior of units with water. Do not use power cleaning equipment, steel wool, scrapers or wire brushes on stainless steel or painted surfaces.

MAINTENANCE SCHEDULE

Maintenance	At Start-up	Daily	Weekly	Monthly	After Prolonged Shutdown	Every 5 Years
Kegs		X			X	
Interior	X	X			X	
Gasket	X	X		X	X	
Exterior	X	X			X	
Drain	X		X		X	
Condenser Coil	X			X	X	
Casters	X			X	X	
Nitrogenator PRV						X

NOTE: The Pressure Relief Valve (PRV) on the nitrogenator tank needs to be replaced every 5 years by a trained technician or service agent.

GENERAL CLEANING

Interior Cleaning

Notice

When cleaning interior and exterior of unit, care should be taken to avoid the rear power cord. Keep water and/or cleaning solutions away from electrical parts.

Important

Never use a high-pressure water jet for cleaning or hose down or flood interior or exterior of units with water. Do not use power cleaning equipment, steel wool, scrapers or wire brushes on stainless steel or painted surfaces.

The interior can be cleaned using soap and warm water. If this isn't sufficient, try ammonia and water or a nonabrasive liquid cleaner.

Exterior Cleaning

Caution

Never use an acid-based cleaning solution! Many food products have an acidic content, which can deteriorate the finish. Be sure to clean the stainless steel surfaces of ALL food products.

Clean the area around the unit as often as necessary to maintain cleanliness and efficient operation.

Wipe gasket and surfaces with a damp cloth rinsed in water to remove dust and dirt from the outside of the unit. Always rub with the "grain" of the stainless steel to avoid marring the finish. If a greasy residue persists, use a damp cloth rinsed in a mild dish soap and water solution. Wipe dry with a clean, soft cloth.

Never use steel wool or abrasive pads for cleaning. Never use chlorinated, citrus based or abrasive cleaners.

Stainless steel exterior panels have a clear coating that is stain resistant and easy to clean. Products containing abrasives will damage the coating and scratch the panels.

Daily cleaning may be followed by an application of stainless steel cleaner which will eliminate water spotting and fingerprints. Early signs of stainless steel breakdown are small pits and cracks. If this has begun, clean thoroughly and start to apply stainless steel cleaners in attempt to restore the steel.

CLEANING SUPPLIES

1. Gather an approved cleaner and sanitizer.



- Only use approved cleaners and sanitizers.

APPROVED CLEANERS

- Urnex® Cafiza® Espresso Machine Cleaner mixed one (1) teaspoon per gallon, must be used. This cleaner is compatible with equipment metals and materials.
- KAY-5® Sanitizer/Cleaner mixed one (1) packet in 2.5 gallons (9.5L) of lukewarm water to equal 100 ppm chlorine. This is also used for the single step weekly cleaning *page 29*

APPROVED SANITIZERS

- KAY-5® Sanitizer/Cleaner mixed one (1) packet in 2.5 gallons (9.5L) of lukewarm water to equal 100 ppm chlorine. This is also used for the single step weekly cleaning *page 29*
- Quat based Urnex® Complete Cafe™ mixed 1/2 oz per gallon providing 400 ppm. Used in 3 step weekly cleaning *page 31*

Warning

Powdered cleaners and sanitizers must be thoroughly mixed into water/solution to prevent crystals from remaining and causing damage to system components.

2. Three (3) clean and sanitized three (3) gallon (11.36L) pressure kegs.

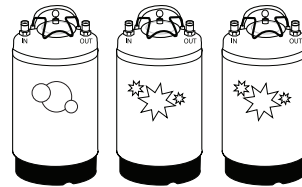

- One (1) for cleaning solution.
- Two (2) for sanitizing solution.

NOTE: Only 1 keg will be needed during single step weekly cleaning *page 29*

Important

Kegs used for cleaning, sanitizing solutions and rinse water should be emptied and cleaned before reuse.

3. Towels, wipes, brushes, and buckets.

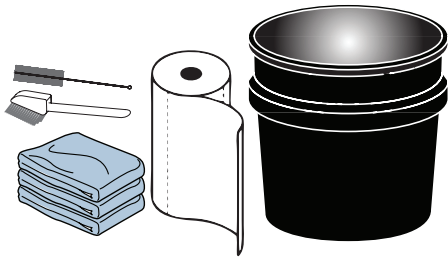

- Use clean towels for any spilled fluid during cleaning process.
- Small cleaning wipes for cleaning top, sides, and interior of unit.
- A small brush is useful to clean keg connections
- Small bucket should be available for dipping keg connections into sanitizer.

4. Spray bottles and PPE (gloves, goggles).

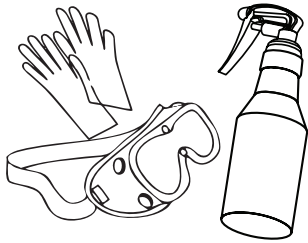

Warning

When in contact with cleaning and sanitizing solution chemicals gloves and safety glasses are recommended.

- Use spray bottle when wiping down surfaces and other exterior parts.
- Gloves and eye protection should be worn to lessen chance of irritation or injury.

MANUAL KEG CLEANING

This is to be performed when a product keg is empty prior to filling the keg with new product.

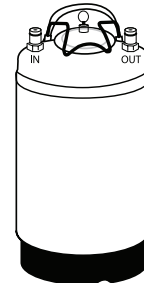

1. Empty remaining product from the keg into the 3-compartment sink.
2. Add QSR Heavy Duty Multi-Purpose Sink Detergent™ from the dispenser at the back room sink, or other approved cleaning solution mixed to the proper concentration, with warm tap water in the keg.
3. Use the urn brush to scrub the inside of the keg and lid, loosening coffee soils, oils, and residue.
4. Empty the dirty soapy water into the 3-compartment sink.

NOTE: Take care not to damage the inner parts of the keg including the stem.

5. Fill half the keg with clean water, replace the lid, and agitate the keg to thoroughly rinse the inside of the keg.
6. Empty the rinse water into the 3-compartment sink.
7. Mix proper concentration of approved sanitizing solution (400 ppm Quat concentrate) in the keg with warm tap water.
8. Replace the lid and agitate the keg to thoroughly sanitize the inside of the keg.
9. Allow the sanitizer to sit inside of the keg for at least one minute.
10. Empty the sanitizer solution into the 3-compartment sink.
11. Store the keg and lid in a location that protects the keg from overhead contamination.
12. Allow the keg and lid to fully air dry before next use.

LEVEL 1 - DAILY CLEANING

Cleaning

1. Put on gloves and safety goggles before cleaning unit.
2. Spray each tap with cleaner, wipe down, look for obstructions, and check for proper flow.

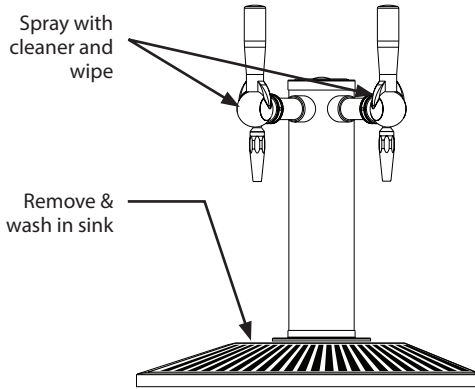

3. Drain gate should be removed, interior of drain pan cleaned, and wiped dry.
4. Wash drain gate in sink and allow to dry.
5. Spray top surface of unit with cleaner and wipe dry.
6. Check interior for any spills or drips, spray with cleaner and wipe down.

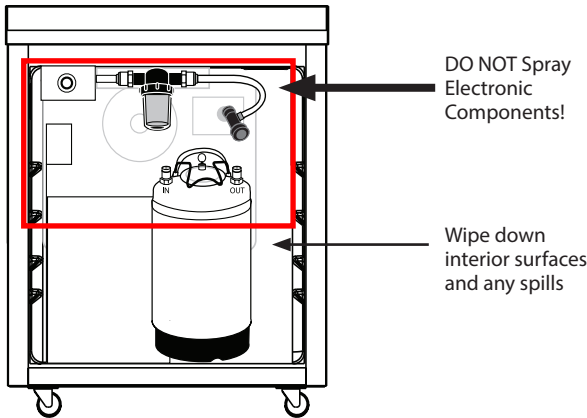

⚠ Caution
 Attention and care should be used to avoid spraying any electrical component (fans, thermostat and sensor connections) with any of the fluids.

7. Pull unit out and clean around the cabinet.

Sanitizing

1. Add approved sanitizer to spray bottle mixed to appropriate ppm concentration and spray all external surfaces. Allow to remain for 15 minutes, or as directed by manufacturer, before wiping off.

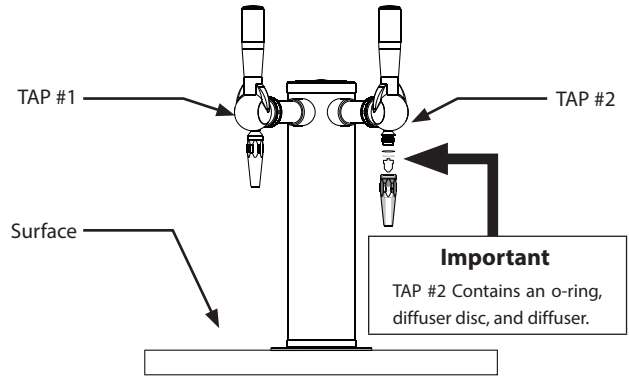

2. Spray each nozzle and allow to air soak for 15 minutes, or as directed by manufacturer, before wiping off.

NOTE: If removing tap nozzles to clean/sanitize, tap 2 contains an o-ring and diffuser. DO NOT lose the diffuser and make sure it is put back on tap 2 after cleaning/sanitizing.

HOW TO REMOVE NOZZLES

- A. Rotate nozzle counter-clockwise by hand, no tool should be required for removal.

NOTE: Be aware of the diffuser and o-ring in the tap 2 nitro nozzle. If they are taken out of the nozzle replace in the correct order as illustrated above.

HOW TO INSTALL NOZZLES

- A. To re-install the nozzle, thread the nozzle back onto the tap by turning clockwise and firmly hand tighten to prevent leaks, no tool required for installation.

Important
 Coffee on tap 2 will not be nitrogenized properly if the correct nozzle with diffuser are not installed.

3. Spray internal surfaces and allow to air soak for 15 minutes, or as directed by manufacturer, before wiping off.

⚠ Caution
 Attention and care should be used to avoid spraying any electrical component (fans, thermostat and sensor connections) with any of the fluids.

Rinsing

Wipe down each nozzle with wet clean towel and allow to air dry. If Keg was disconnected and cleaned/sanitized, wipe down connectors with clean wet towel and allow to air dry.

Clean In-line Strainer

1. Locate the in-line coffee strainer on the ceiling of the refrigeration cabinet.

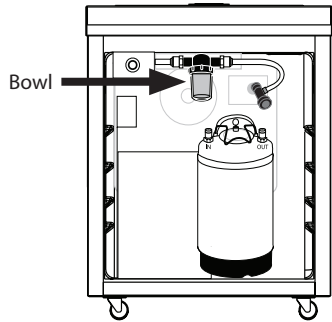

HOW TO REMOVE STRAINER

- A. First depressurize the system and disconnect the keg. See "Keg Change" on page 21
- B. Put down a towel or small cloth to catch any coffee that may still be in the line or bowl during removal.
- C. Grasp the bowl and rotate counterclockwise to loosen and remove the bowl.

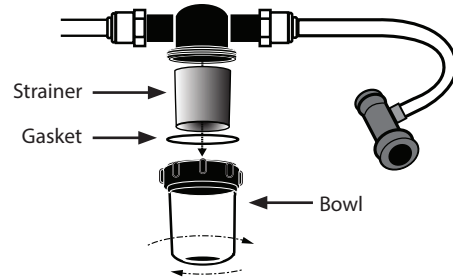

NOTE: The strainer is a metal mesh ring that will be located inside the bowl. Also be careful not to damage the rubber gasket that is seated in the bowl.

- D. Visually inspect the clear strainer bowl for debris and coffee grinds.
- E. Rinse under tap water, scrub thoroughly inside and out with the tube brush included with the unit.
- F. Clean and sanitize before putting back into place.
- G. Reassemble the bowl with mesh and gasket back in place.
- H. Rotate bowl clockwise and hand tighten.
- I. Reconnect the keg and check for leaks.

Important

Strainer should be cleaned at minimum once a day.

THIS PAGE INTENTIONALLY LEFT BLANK

LEVEL 2 - WEEKLY CLEANING (SINGLE STEP METHOD)

Important

One of the Level 2 methods is to be performed daily on the Milk line.

NOTE: Only to be performed using **KAY-5®** Sanitizer/Cleaner, if **KAY-5®** Sanitizer/Cleaner is not available the three step, Clean, Rinse, Sanitize method must be performed. See "Level 2 - Weekly Cleaning (Three Step Method)" on page 31

1. Approved Sanitizer / Cleaner.



APPROVED CLEANER/SANITIZER

- **KAY-5®** Sanitizer/Cleaner mixed one (1) packet in 2.5 gallons (9.5L) of lukewarm water to equal 100 ppm chlorine. This sanitizer / cleaner is compatible with equipment metals and materials.

NOTE: The cleaner / sanitizer must provide 100 ppm chlorine, use the provided 2.5 (9.5L) measuring bucket to ensure proper ratio.

Warning

Powdered cleaners and sanitizers must be thoroughly mixed into water/solution to prevent crystals from remaining and causing damage to system components.

Make sure one (1) properly cleaned and sanitized cleaning keg is available to perform proper weekly cleaning. See "Manual Keg Cleaning" on page 25 & "Level 3 - Monthly Cleaning" on page 34

Coffee Delivery System Cleaning & Sanitizing

1. Disconnect coffee keg and set aside.

Clean In-line Strainer

2. De-pressurize the system. See "Keg Change" on page 21 then See "Clean In-line Strainer" on page 27.

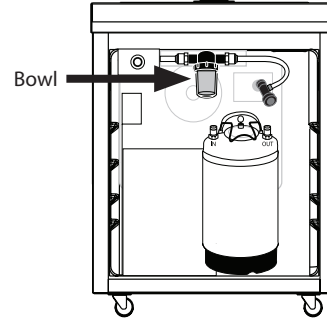

3. Reassemble the bowl with mesh and gasket back in place.

Cleaning the System

4. Mix proper concentration of **KAY-5®** Sanitizer/Cleaner solution in the three (3) gallon cleaning keg with warm tap water.
5. Connect the outlet (OUT) then inlet (IN) keg connectors cleaning solution keg.
6. Press and release the Prime/Clean button to prime the system with cleaning/sanitizing solution. The LED around the button will flash ON then OFF.

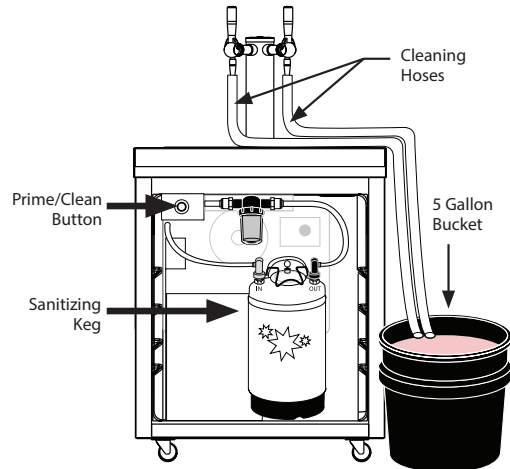

7. Place a clean five (5) gallon bucket on the floor in front of unit.
8. Place clear nozzle cleaning hose over nozzles of both the (plain and nitrogen coffee) taps and place other end of clear hoses in the five (5) gallon bucket.
9. Open both the plain and nitrogen coffee taps.
10. Press and hold the Prime/Clean button until the LED around the button turns on to place the unit into cleaning mode.

NOTE: Cleaning button will illuminate blue in color around the button indicating unit is in cleaning mode.

11. Unit will automatically run through the cleaning/sanitizing process.
12. Towards the end of cleaning /sanitizing process there will be a system purge process and once bubbles are seen coming from five (5) gallon bucket, close plain coffee tap.
13. Once cleaning /sanitizing process is complete the LED will not be illuminated, which indicates cleaning is complete and both product taps can now be closed.

NOTE: To abort cleaning mode at any time press and hold the cleaning button until the LED around the Prime/Clean button turns OFF. This exits cleaning mode into keg change mode and LED will no longer be illuminated.

NOTE: Priming is required after aborting cleaning or clearing an error. See *"Priming the System"* on page 20

Important

If cleaning mode is accidentally aborted or aborted because of an issue/reason, then the cleaning process will need to start over from the beginning after a two (2) minute wait.

NOTE: If an error is encountered at any time during cleaning process the cleaning button will blink ON/OFF rapidly indicating unit is in an error state and cleaning process has stopped. See *"Clearing Error Code"* on page 20.

14. Disconnect cleaning keg and set aside.
15. Disconnect clear drain hoses from tap nozzles, empty five (5) gallon bucket and store for use during next weekly cleaning.

Important

Kegs used for cleaning & sanitizing solutions should be emptied and cleaned before reuse.

Clean In-line Strainer

16. Once the cleaning/sanitizing is complete the strainer will need cleaned again to ensure no new debris have been trapped in the filter.
17. De-pressurize the system. See *"Keg Change"* on page 21 then See *"Clean In-line Strainer"* on page 27.
18. Reassemble the bowl with mesh and gasket back in place.
19. Complete all other weekly cleaning tasks before reconnecting coffee keg to unit. See *"Interior/Exterior Cleaning, Sanitizing & Rinse"* on page 34, and See *"Keg Connector Cleaning"* on page 33.

LEVEL 2 - WEEKLY CLEANING (THREE STEP METHOD)

1. Approved cleaner and sanitizer.



- Only use approved cleaners and sanitizers.

APPROVED CLEANERS

- Urnex® Cafiza® Espresso Machine Cleaner mixed one (1) teaspoon per gallon, must be used. This cleaner is compatible with equipment metals and materials.
- KAY-5® Sanitizer/Cleaner mixed one (1) packet in 2.5 gallons (9.5L) of lukewarm water to equal 100 ppm chlorine.

APPROVED SANITIZERS

- KAY-5® Sanitizer/Cleaner mixed one (1) packet in 2.5 gallons (9.5L) of lukewarm water to equal 100 ppm chlorine.
- Quat based Urnex® Complete Cafe™ mixed 1/2 oz per gallon providing 400 ppm. Used in 3 step weekly cleaning page 31

Make sure three (3) properly cleaned and sanitized cleaning kegs are available to perform proper weekly cleaning. See "Manual Keg Cleaning" on page 25 & "Level 3 - Monthly Cleaning" on page 34

Coffee Delivery System Cleaning & Sanitizing

1. Disconnect coffee keg and set aside.

Clean In-line Strainer

2. De-pressurize the system. See "Keg Change" on page 21 then See "Clean In-line Strainer" on page 27.

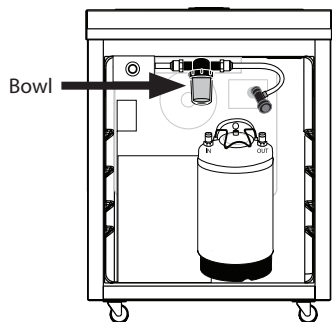

3. Reassemble the bowl with mesh and gasket back in place.

Cleaning the System

4. Mix proper concentration of cleaning solution in one of the three (3) gallon kegs with warm tap water.
5. Connect the outlet (OUT) then inlet (IN) keg connectors cleaning solution keg.
6. Press and release the Prime/Clean button to prime the system with cleaning solution. The LED around the button will flash ON then OFF.

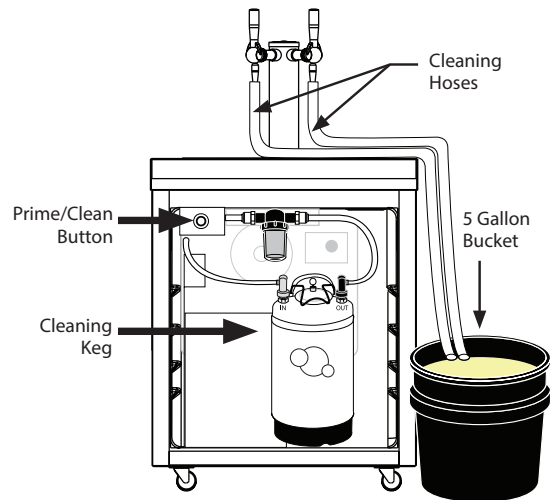

7. Place a clean five (5) gallon bucket on the floor in front of unit.
8. Place clear nozzle cleaning hose over nozzles of both the (plain and nitrogen coffee) taps and place other end of clear hoses in the five (5) gallon bucket.
9. Open both the plain and nitrogen coffee taps.
10. Press and hold the Prime/Clean button until the LED around the button turns on to place the unit into cleaning mode.

NOTE: Cleaning button will illuminate blue in color around the button indicating unit is in cleaning mode.

11. Unit will automatically run through the cleaning process.
12. Towards the end of cleaning process there will be a system purge process and once bubbles are seen coming from five (5) gallon bucket, close plain coffee tap.
13. Once cleaning process is complete the LED will not be illuminated, which indicates cleaning is complete and both product taps can now be closed.
14. Empty the five (5) gallon bucket and place ends of clear nozzle drain hoses back into bucket.
15. Disconnect cleaning solution keg and set aside, then continue to "Rinsing & Sanitizing the System" on page 32.

NOTE: To abort cleaning mode at any time press and hold the cleaning button until the LED around the Prime/Clean button turns OFF. This exits cleaning mode into keg change mode and LED will no longer be illuminated.

NOTE: Priming is required after aborting cleaning or clearing an error. See *"Priming the System"* on page 20

Important

If cleaning mode is accidentally aborted or aborted because of an issue/reason, then the cleaning process will need to start over from the beginning after a two (2) minute wait.

NOTE: If an error is encountered at any time during cleaning process the cleaning button will blink ON/OFF rapidly indicating unit is in an error state and cleaning process has stopped. See *"Clearing Error Code"* on page 20.

Rinsing & Sanitizing the System

1. Mix proper concentration of approved sanitizing solution (400 ppm Quat concentrate) in the second three (3) gallon keg with warm tap water.

NOTE: If this is the second time sanitizing use the third and final three (3) gallon keg.

2. Connect the outlet (OUT) then inlet (IN) keg connectors of unit to sanitizing solution keg.

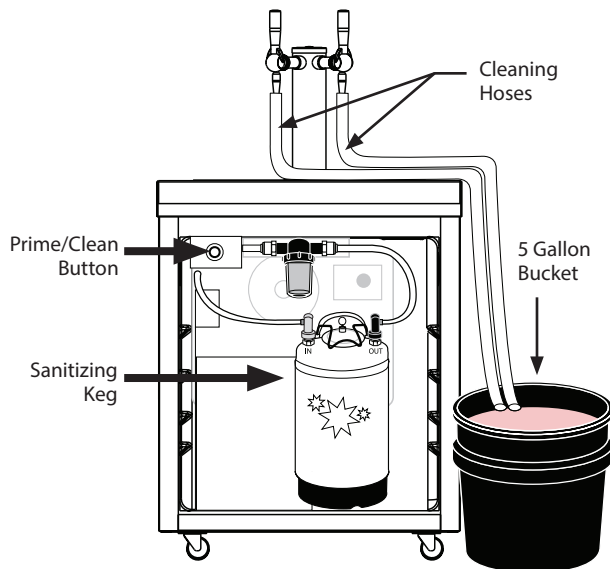

3. Press and release the Prime/Clean button to prime the system with sanitizing solution. The LED around the button will flash ON then OFF.
4. Make sure the cleaning hoses are connected to the taps and the other ends are in the 5 gallon bucket.
5. Open both the plain and nitrogen coffee taps.
6. Press and hold the Prime/Clean button until the LED around the button turns on to place the unit into cleaning mode.

NOTE: Cleaning button will illuminate blue in color around the button indicating unit is in cleaning mode.

7. Unit will automatically run through the cleaning process.
8. Towards the end of sanitizing process there will be a system purge process and once bubbles are seen coming from five (5) gallon bucket, close plain coffee tap.
9. Once sanitizing process is complete cleaning button will not be illuminated, which indicates sanitizing is complete and both product taps should be closed.
10. Empty the five (5) gallon bucket and place ends of clear nozzle drain hoses back into bucket.
11. Disconnect sanitizer solution keg two (2) and set aside.
12. Repeat "Rinsing & Sanitizing the System" Step 1 through Step 11 to completely sanitize the system before continuing to Step 13.
13. Disconnect clear drain hoses from tap nozzles, empty five (5) gallon bucket and store for use during next weekly cleaning.

Important

Kegs used for cleaning & sanitizing solutions should be emptied and cleaned before reuse.

Clean In-line Strainer

14. Once the final sanitizing is complete the strainer will need cleaned again to ensure no new debris have been trapped in the filter.
15. De-pressurize the system. See *"Keg Change"* on page 21 then See *"Clean In-line Strainer"* on page 27.
16. Reassemble the bowl with mesh and gasket back in place.
17. Complete all weekly cleaning tasks before reconnecting coffee keg to unit. See *"Interior/Exterior Cleaning, Sanitizing & Rinse"* on page 34, and See *"Keg Connector Cleaning"* on page 33.

Keg Connector Cleaning

1. If keg is not disconnected, then do so and set keg aside.

⚠ Warning

NEVER ATTEMPT TO REMOVE KEG LID WITHOUT FIRST DE-PRESSURIZING KEG!

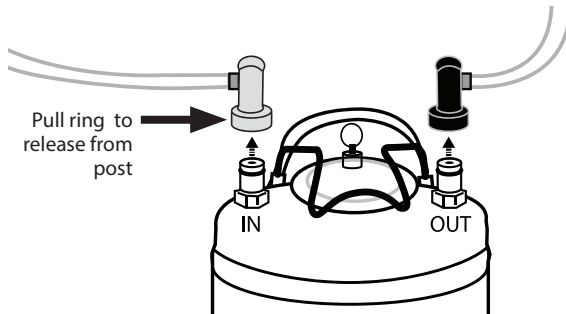

2. Spray cleaner on one keg connector and wipe down with clean towel.

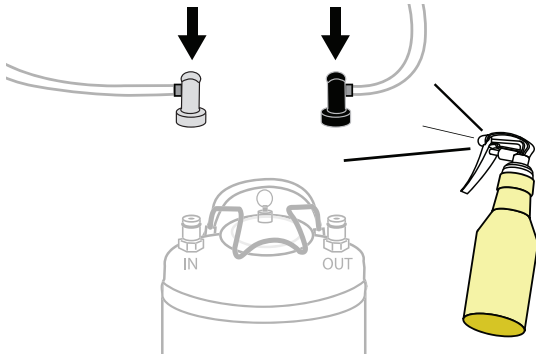

3. If required a brush can be used for stains or residue build-up.
4. Repeat Step 1 and 2 for other keg connectors.

Keg Connector Sanitizing

- Frequency: Every week or as required.
1. Mix proper concentration of approved sanitizing solution in clean bucket and place keg connectors into bucket and allow to soak for 15 minutes, or as directed by manufacturer.

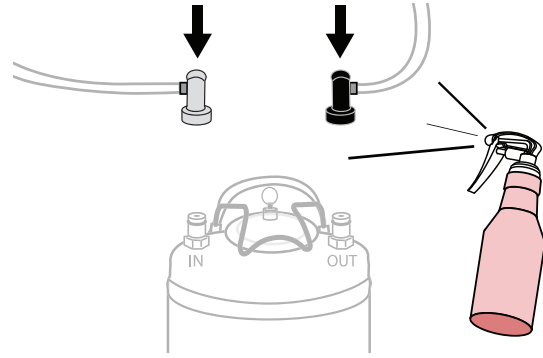

NOTE: An alternative method is to heavily spray both of the connectors with sanitizing solution and allow sanitizer to remain for fifteen (15) minutes or as directed by manufacturer.

2. Once keg connectors are cleaned and sanitized each one should be immersed into clean water for at least five (5) minutes for rinsing.

Interior/Exterior Cleaning, Sanitizing & Rinse

1. Put on gloves and safety goggles before cleaning unit.
2. Spray each tap with cleaner, wipe down, look for obstructions, and check for proper flow.
3. Drain gate should be removed and interior of drain pan cleaned and wiped dry.
4. Wash drain gate in sink and allow to dry.
5. Spray top surface of unit with cleaner and wipe dry.
6. Check interior for any spills or drips, spray with cleaner and wipe down.

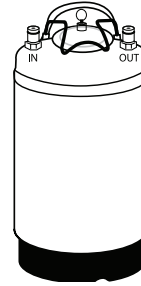

Perform the a weekly cleaning on all six (6) store kegs, three (3) product and three (3) cleaning. This can be performed during the weekly cleaning once a month.

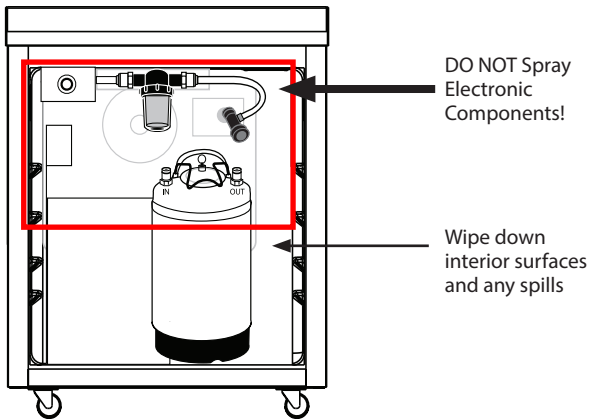

⚠ Caution

Attention and care should be used to avoid spraying any electrical component (fans, thermostat and sensor connections) with any of the fluids.

Connect Keg & Prime System

Once all cleaning has been completed the keg can be reconnected to the system.

Important

Make sure new coffee keg has been chilled to the operating temperature range of 45° - 36°F (7° - 2°C) before use or may cause foaming in the system.

- See "Keg Change" on page 21
- Close cabinet door and unit is ready for use.

LEVEL 3 - MONTHLY CLEANING

In Place Keg Cleaning

Other Operations

DOORS & HINGES

Over time and with heavy-use doors, the hinges may become loose. If this happens, tighten the screws that mount the hinge brackets to the frame of the unit. Loose or sagging doors can cause the hinges to pull out of the frame, which may damage both the doors and the hinges. In some cases this may require qualified service agents or maintenance personnel to perform repairs.

Door Adjustment

If the door needs lowering at the handle, use a 5/16" (8 mm) wrench to loosen the hinge screws and install a spacer outside of the hinge. Tighten the screws.

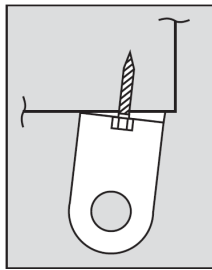

If the door needs to be higher at the handle, use a 5/16" (8 mm) wrench to loosen the hinge screws and install a spacer inside of the hinge. Tighten the screws.

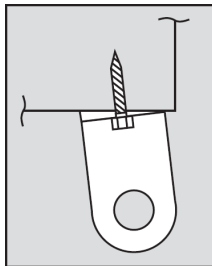

THIS PAGE INTENTIONALLY LEFT BLANK

Section 5 Troubleshooting

Troubleshooting Charts

Prior to contacting Service please find the issue in one of the charts and perform the correction, if the issue is not listed or persists then contact Service.

DISPENSING ISSUES		
Problem	Cause	Correction
Coffee does not dispense	Power	Is there power to the unit? Plug in unit.
	Product keg is empty	Change out the product keg. See "Keg Change" on page 21
	Keg connectors not connected	Check keg connectors. See "Keg Change" on page 21
	Low / No Nitrogen pressure.	Open Nitrogen tank valve, adjust pressure, or change N ₂ supply tank. See "Nitrogen Installation/Replacement" on page 13
	Nitrogen supply tank is empty	Change out the Nitrogen supply tank. See "Nitrogen Installation/Replacement" on page 13
	Debris in in-line strainer/filter	Clean filter. See "Clean In-line Strainer" on page 31
	Product line is not primed	Press the Prime/Clean button for one second to prime system
	Stuck in clean cycle	Is Prime/Clean LED ON , press & hold till turns OFF
	Error mode, Prime/Clean button blinking	See "Clearing Error Code" on page 20
Nitrogen Supply Tank OFF	Turned OFF when tank was swapped/installed.	Check Nitrogen tank. See "Nitrogen Installation/Replacement" on page 13
	Tank incorrectly shut OFF during keg change.	
The coffee seems to be watery	Is the cleaning / purge light button on	Finish cycle & replace the product keg. See "Keg Change" on page 21
The coffee is warmer than expected	Verify the thermometer reads below 50°F	Refer to refrigeration section checklist. See "Controls/Programming/Settings" on page 19 and "Keg Change" on page 21
Coffee keeps leaking from the clear drain hose	The nitrogenator tank relief valve is stuck open	Close or replace.
There is a hissing sound coming from the nitrogen tank	Regulator nut	Tighten regulator nut. See "Nitrogen Regulator & Tank Assembly" on page 13
		Check for missing washer inside of regulator nut.
There is a puddle of product on the floor	Drain tube	Check to see if cabinet drain is in the floor drain. See "N ₂ Quick Disconnect & Drain" on page 33
The drain pan under the taps has standing coffee	Pinched or clogged drain line	Clean out drain line.
		Replace drain line.
Product does not appear to be nitrogenated	Nitro Coffee nozzle does not have diffuser installed	Check cold brew nozzle to see if nozzles were reversed. Nozzle with diffuser disc is intended to be installed on the Nitro side of the tower.
Product flowing slow from valve	Debris in nozzle	Remove nozzle and clean. See "How to Remove Nozzles" on page 26
	Debris in filter	Remove and Clean Filter. See "Clean In-line Strainer" on page 27
	Check Nitro pressure gauge	Make sure pressures are set correctly. See "Nitrogen Connections & Pressures" on page 14 and "Keg & Pump Regulators" on page 15
	Nitrogen pump not running	Call for service
	If no other cause was found, the flow control collar on valve may be out of adjustment	Call Service to have adjusted.
Foam dispensing from valve	Cold brew temp above 45 degrees	Attach keg of cold brew that is chilled to below 45°F. See "Keg Change" on page 21

DISPENSING ISSUES		
Problem	Cause	Correction
Cleaning button blinking ON/OFF rapidly	Unit is in an error state and cleaning process has stopped., keg empty.	Hold Prime/Clean button until the LED turns OFF. (See "Clearing Error Code" on page 20)
	System fails to prime. Pump runs continuously for >5 minutes.	Replace keg if needed then press and release the Prime/Clean button again to prime the new keg. Cleaning process can be started over after a two (2) minute wait.
Keg connectors won't go onto the keg posts	Incorrect connector	Make sure the IN connector is gray and the OUT connector is black. See "Keg Change" on page 21
	Not pulling up on the connector release ring while connecting	Pull up on the ring around the connector to allow it to slip over the IN or OUT post and lock into place. See "Keg Change" on page 21

REFRIGERATOR CABINET ISSUES		
Problem	Cause	Correction
Cabinet not running	Fuse blown or circuit breaker tripped.	Replace fuse or reset circuit breaker.
	Power cord unplugged.	Plug in power cord.
	Thermostat set too high.	Set thermostat to lower temperature.
Condensing unit runs for long periods or continuously	Excessive amount of warm product placed in cabinet.	Allow adequate time for product to cool down.
	Prolonged door openings or door(s) ajar.	Make sure door(s) are closed when not in use. Avoid prolonged door openings.
	Door gasket(s) not sealing properly.	Check gasket condition. Adjust door or replace gasket if necessary.
	Dirty condenser coil.	Clean the condenser coil.
Cabinet temperature is too high	Evaporator coil iced over.	Turn unit off and allow coil to defrost. Make sure thermostat is not set too cold. Also, check gasket condition.
	Thermostat set too high.	Set thermostat to lower temperature.
	Poor air circulation in cabinet.	Re-arrange product to allow proper air circulation.
	Excessive amount of warm product placed in cabinet.	Allow adequate time for product to cool down.
	Prolonged door openings or door(s) ajar.	Make sure door(s) are closed when not in use. Avoid prolonged door openings.
	Dirty condenser coil.	Clean the condenser coil.
Cabinet is noisy	Evaporator coil iced over.	Turn unit off and allow coil to defrost. Make sure thermostat is not set too cold. Also, check gasket condition.
	Loose part(s).	Locate and tighten loose part(s).
Refrigerator is freezing product	Thermostat is set too low.	Set thermostat to higher temperature.
	Dirty condenser coil.	Clean the condenser coil.
	Not enough cabinet clearance for proper refrigeration system operation.	Move cabinet or make other adjustments to gain proper cabinet clearances.
Compressor will not start	Low voltage to cabinet.	Check and correct incoming voltage to cabinet.
Leaking internally	Check the in-line filter bowl and o-ring.	May need to depressurize the unit and remove the filter bowl to check. See "How to Remove Strainer" on page 27

POURING

If coffee does not pour out of taps items to check are;

1. Verify connections to keg and if coffee keg is empty. If keg is empty follow replacement steps on page 16.

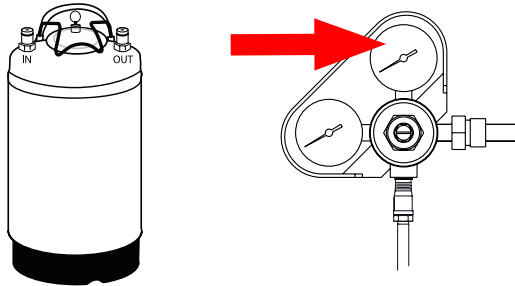

2. If keg has coffee check nitrogen level at nitrogen tank.
 - If outlet pressure drops below 85 - 90 PSI (.586 - .621 MPa, 586 - 621 kPa, 5.86 - 6.21 bar) or tank volume is low replace tank and connect as shown on page 14.

THIS PAGE INTENTIONALLY LEFT BLANK

**WELBILT**[®]
*Bringing innovation to the table***WWW.WELBILT.COM**

Welbilt provides the world's top chefs, and premier chain operators or growing independents with industry leading equipment and solutions. Our cutting-edge designs and lean manufacturing tactics are powered by deep knowledge, operator insights, and culinary expertise. All of our products are backed by KitchenCare[®] – our aftermarket, repair, and parts service.

▶ CLEVELAND

▶ CONVOTHERM[®]▶ DELFIELD[®]▶ FITKITCHEN[™]▶ FRYMASTER[®]

▶ GARLAND

▶ KOLPAK[®]

▶ LINCOLN

▶ MANITOWOC[®]▶ MERCO[®]▶ MERRYCHEF[®]▶ MULTIPLY[®]