



**Multiplex**<sup>®</sup>

# MII SERIES

MII-250/302 Beverage/Ice Dispenser with Flex Manifold

## INSTALLATION & SERVICE GUIDE

PARTNUMBER 5031216



ISO 9001:2000  
Quality System Certified



### Manitowoc Beverage Equipment

2100 Future Drive • Sellersburg, IN 47172-1868  
Tel: 812.246.7000, 800.367.4233 • Fax: 812.246.9922  
[www.manitowocbeverage.com](http://www.manitowocbeverage.com)

In accordance with our policy of continuous product development and improvement, this information is subject to change at any time without notice.

October 17, 2006 REV3





# FOREWORD

---

Manitowoc Beverage Equipment (MBE) developed this manual as a reference guide for the owner/operator, service agent, and installer of this equipment. Please read this manual before installation or operation of the machine. A qualified service technician should perform installation and start-up of this equipment, consult the *Troubleshooting Guide* within this manual for service assistance.

If you cannot correct the service problem, call your MBE Service Agent or Distributor. Always have your model and serial number available when you call.

Your Service Agent \_\_\_\_\_

Service Agent Telephone Number \_\_\_\_\_

Your Local MBE Distributor \_\_\_\_\_

Distributor Telephone Number \_\_\_\_\_

Model Number \_\_\_\_\_

Serial Number \_\_\_\_\_

Installation Date \_\_\_\_\_

## UNPACKING AND INSPECTION

---

Note: The dispenser was thoroughly inspected before leaving the factory. Any damage or irregularities should be noted at the time of delivery.

## WARRANTY INFORMATION

---

Consult your local MBE Distributor for terms and conditions of your warranty. Your warranty specifically excludes all beverage valve brixing, general adjustments, cleaning, accessories and related servicing.

Your warranty card must be returned to Manitowoc Beverage Equipment to activate the warranty on this equipment. If a warranty card is not returned, the warranty period can begin when the equipment leaves the MBE factory.

No equipment may be returned to Manitowoc Beverage Equipment without a written Return Materials Authorization (RMA). Equipment returned without an RMA will be refused at MBE's dock and returned to the sender at the sender's expense.

Please contact your local MBE distributor for return procedures.

# TABLE OF CONTENTS

---

<b>FOREWORD</b> .....	<b>3</b>
<b>UNPACKING AND INSPECTION</b> .....	<b>3</b>
<b>WARRANTY INFORMATION</b> .....	<b>3</b>
<b>SAFETY</b> .....	<b>6</b>
<b>IMPORTANT SAFETY INSTRUCTIONS</b> .....	<b>6</b>
<b>CARBON DIOXIDE WARNING</b> .....	<b>6</b>
<b>QUALIFIED SERVICE PERSONNEL</b> .....	<b>6</b>
<b>SHIPPING, STORAGE, AND RELOCATION</b> .....	<b>6</b>
<b>ADDITIONAL WARNINGS</b> .....	<b>6</b>
<b>GROUNDING IN STRUCTIONS</b> .....	<b>7</b>
<b>INSTALLATION</b> .....	<b>8</b>
<b>PRE-INSTALLATION CHECK LIST</b> .....	<b>8</b>
<b>UNIT INSTALLATION</b> .....	<b>8</b>
<b>MII-250 INSTALLATION KIT</b> .....	<b>9</b>
<b>MII-302 INSTALLATION KIT</b> .....	<b>10</b>
<b>WATER &amp; SYRUP LINES</b> .....	<b>11</b>
<b>DRAINAGE OPTIONS</b> .....	<b>12</b>
<b>BAG-IN-BOX (B-I-B) SYSTEM</b> .....	<b>13</b>
<b>TOP MOUNTED ICEMAKER REQUIREMENTS</b> .....	<b>14</b>
<b>ICE FLOW RESTRICTOR</b> .....	<b>14</b>
<b>ROCKING CHUTE ICE DELIVERY SWITCH ADJUSTMENT</b> .....	<b>15</b>
<b>BAFFLE FOR MANITOWOC™ CUBERS</b> .....	<b>16</b>
<b>BAFFLE FOR "Q" SERIES ICE MACHINES</b> .....	<b>16</b>
<b>MANUAL FILL LID FOR DISPENSERS WITH A CUBER</b> .....	<b>16</b>
<b>GENERAL INSTRUCTIONS FOR REMOVAL OF GEAR MOTOR</b> .....	<b>17</b>
<b>MII-250 PLUMBING DIAGRAM</b> .....	<b>18</b>
<b>MII-302 PLUMBING DIAGRAM</b> .....	<b>18</b>
<b>OPERATION</b> .....	<b>19</b>
<b>UNIT INSPECTION</b> .....	<b>19</b>
<b>ICE RECOMENDED FOR DISPENSING</b> .....	<b>19</b>
<b>ICE STORAGE AND DISPENSING</b> .....	<b>19</b>
<b>BEVERAGE VALVES</b> .....	<b>19</b>
<b>ROCKING CHUTE ICE DISPENSING</b> .....	<b>19</b>
<b>LEGS</b> .....	<b>19</b>
<b>MII-250 MEASUREMENTS &amp; SPECIFICATIONS</b> .....	<b>20</b>
<b>MII-302 MEASUREMENTS &amp; SPECIFICATIONS</b> .....	<b>21</b>
<b>MII-250 FOOTPRINT</b> .....	<b>22</b>
<b>MII-302 FOOTPRINT</b> .....	<b>23</b>

# TABLE OF CONTENTS

---

CARBONATION .....	24
SYRUP DELIVERY SYSTEM .....	24
RACKING .....	24
B-I-B .....	24
PUMPS .....	24
AUTO BAG SELECTORS .....	24
BACK ROOM PACKAGE .....	25
115V/220V NON ADJUSTABLE AGITATION TIMER .....	26
<b>USER MAINTENANCE .....</b>	<b>27</b>
PREVENTATIVE MAINTENANCE .....	27
HOW TO DISASSEMBLE FOR CLEANING OR MAINTENANCE .....	27
DAILY CLEANING .....	30
MONTHLY CLEANING .....	31
BEVERAGE SYSTEM CLEANING .....	32
BAG-IN-BOX SYSTEM .....	32
<b>EXPLODED VIEWS, PARTS &amp; DIAGRAMS .....</b>	<b>34</b>
MII-250 EXPLODED VIEW WITH 8 VALVE FLEX MANIFOLD .....	34
MII-250 PARTS LIST .....	35
MII-302 EXPLODED VIEW WITH TWO 6 VALVE FLEX MANIFOLDS .....	36
MII-302 PARTS LIST .....	37
MII-302 CARB WATER TUBING .....	38
STRIP LID ASSEMBLY (5030332) .....	39
MII-250 115V WIRING DIAGRAM .....	39
MII-302 115V WIRING DIAGRAM .....	40
<b>TROUBLESHOOTING .....</b>	<b>41</b>
<b>INDEX .....</b>	<b>47</b>

# SAFETY

## IMPORTANT SAFETY INSTRUCTIONS

Carefully read all safety messages in this manual. Learn how to operate the MII unit properly. Do not allow anyone to operate the unit without proper training and keep it in proper working condition. Unauthorized modifications to the MII may impair function and/or safety and affect the life of the unit.

### CARBON DIOXIDE WARNING



**DANGER:** Carbon Dioxide (CO<sub>2</sub>) displaces oxygen. Exposure to a high concentration of CO<sub>2</sub> gas causes tremors, which are followed rapidly by loss of consciousness and suffocation. If a CO<sub>2</sub> gas leak is suspected, particularly in a small area, immediately ventilate the area before repairing the leak. CO<sub>2</sub> lines and pumps should not be installed in an enclosed space. An enclosed space can be a cooler or small room or closet. This may include convenience stores with glass door self serve coolers. If you suspect CO<sub>2</sub> may build up in an area, venting of the B-I-B pumps and / or CO<sub>2</sub> monitors should be utilized.

### QUALIFIED SERVICE PERSONNEL



**WARNING:** Only trained and certified electrical and plumbing technicians should service this unit. All wiring and plumbing must conform to national and local codes.

### SHIPPING, STORAGE, AND RELOCATION



**CAUTION:** Before shipping, storing, or relocating this unit, syrup systems must be sanitized. After sanitizing, all liquids (sanitizing solution and water) must be purged from the unit. A freezing environment causes residual sanitizing solution or water remaining inside the unit to freeze, resulting in damage to internal components.

### ADDITIONAL WARNINGS

	<b>CAUTION</b> Unplug unit before servicing or cleaning ice bin. Ice bin contains parts that can move at any time and will cause injury if hands are in the way.
--	--

<b>WARNING</b> Flush sanitizing solution from syrup system Residual sanitizing solution left in system could create a health hazard
---

	<b>WARNING</b> When using cleaning fluids or chemicals, rubber gloves and eye protection should be worn
--	--

	<b>WARNING</b> UNPLUG UNIT BEFORE SERVICING OR CLEANING ELECTRIC SHOCK HAZARD
--	---

Installation and start-up of this equipment should be done by a qualified service technician. Operation, maintenance, and cleaning information in this manual are provided for the user/operator of the equipment. **Save these instructions.**

# SAFETY

## GROUNDING INSTRUCTIONS



**WARNING:** Risk of electrical shock. Connect to a properly grounded outlet only.

This appliance must be grounded. In the event of malfunction or breakdown, grounding provides a path of least resistance for electric current to reduce the risk of electric shock. This appliance is equipped with a cord having an equipment-grounding conductor and a grounding plug. The plug must be plugged into an appropriate outlet that is properly installed and grounded in accordance with all local codes and ordinances.

**DANGER** – Improper connection of the equipment-grounding conductor can result in a risk of electric shock. The conductor with insulation having an outer surface that is green with or without yellow stripes is the equipment grounding conductor. If repair or replacement of the cord or plug is necessary, do not connect the equipment-grounding conductor to a live terminal. Check with a qualified electrician or serviceman if the grounding instructions are not completely understood, or if in doubt as to whether the appliance is properly grounded. Do not modify the plug provided with the appliance – if it will not fit the outlet, have a proper outlet installed by a qualified electrician.

**WARNING** – When using electric appliances, basic precautions should always be followed, including the following:

- a) Read all the instructions before using the appliance.
- b) To reduce the risk of injury, close supervision is necessary when an appliance is used near children.
- c) Do not contact moving parts.
- d) Only use attachments recommended or sold by the manufacturer.
- e) Do not use outdoors.
- f) For a cord-connected appliance, the following shall be included:
  - Do not unplug by pulling on cord. To unplug, grasp the plug, not the cord.
  - Unplug from outlet when not in use and before servicing or cleaning.
  - Do not operate any appliance with a damaged cord or plug, or after the appliance malfunctions or is dropped or damaged in any manner. Return appliance to the nearest authorized service facility for examination, repair, or electrical or mechanical adjustment.
- g) For a permanently connected appliance – Turn the power switch to the off position when the appliance is not in use and before servicing or cleaning.
- h) For an appliance with a replaceable lamp – always unplug before replacing the lamp. Replace the bulb with the same type.
- i) For a grounded appliance – Connect to a properly grounded outlet only. See Grounding Instructions.

**SAVE THESE INSTRUCTIONS**

# INSTALLATION

## PRE-INSTALLATION CHECK LIST

When installing any system, first make sure the major components are available. Generally the major components necessary for an installation are:

### B-I-B System also:

- B-I-B connectors
- B-I-B regulator set
- B-I-B rack
- B-I-B syrup boxes

### Post Mix System:

- CO<sub>2</sub> regulator set
- Beverage dispenser
- Beverage tubing
- CO<sub>2</sub> tank
- Carbonator
- Stepless (Oetiker) clamps
- Chain for CO<sub>2</sub> tank

### Bulk Syrup System also:

- Syrup connectors for Bulk tank
- Gas connectors for Bulk tank
- Bulk syrup tanks

### Double Check:

- Do you have enough space to install the dispenser or a dispenser and top mounted cuber?
- Does the top mounted cuber (if utilized) have a minimum of 6 inches (15.3) cm clearance on all sides?
- Is the countertop level?
- Can the countertop support the weight of the dispenser, or the dispenser/cuber combination plus the weight of the stored ice?

### Also consider the location of the following items before installation:

- Water line
- Drain
- Power outlet
- Heating and air conditioning ducts

## UNIT INSTALLATION



1. Place the dispenser in the desired location.
2. Run the beverage lines and water lines (make sure to install the water connections to the proper inlets).  
*(Refer to plumbing diagrams)*
3. Install drain plumbing and insulate.  
*(See Drainage Options)*
4. Set flexible manifold for correct drink settings.
5. Fill bin with ice.
6. Connect power supply.
7. Brix beverage valves.
10. Meet all code requirements.

# INSTALLATION

## MII-250 INSTALLATION KIT

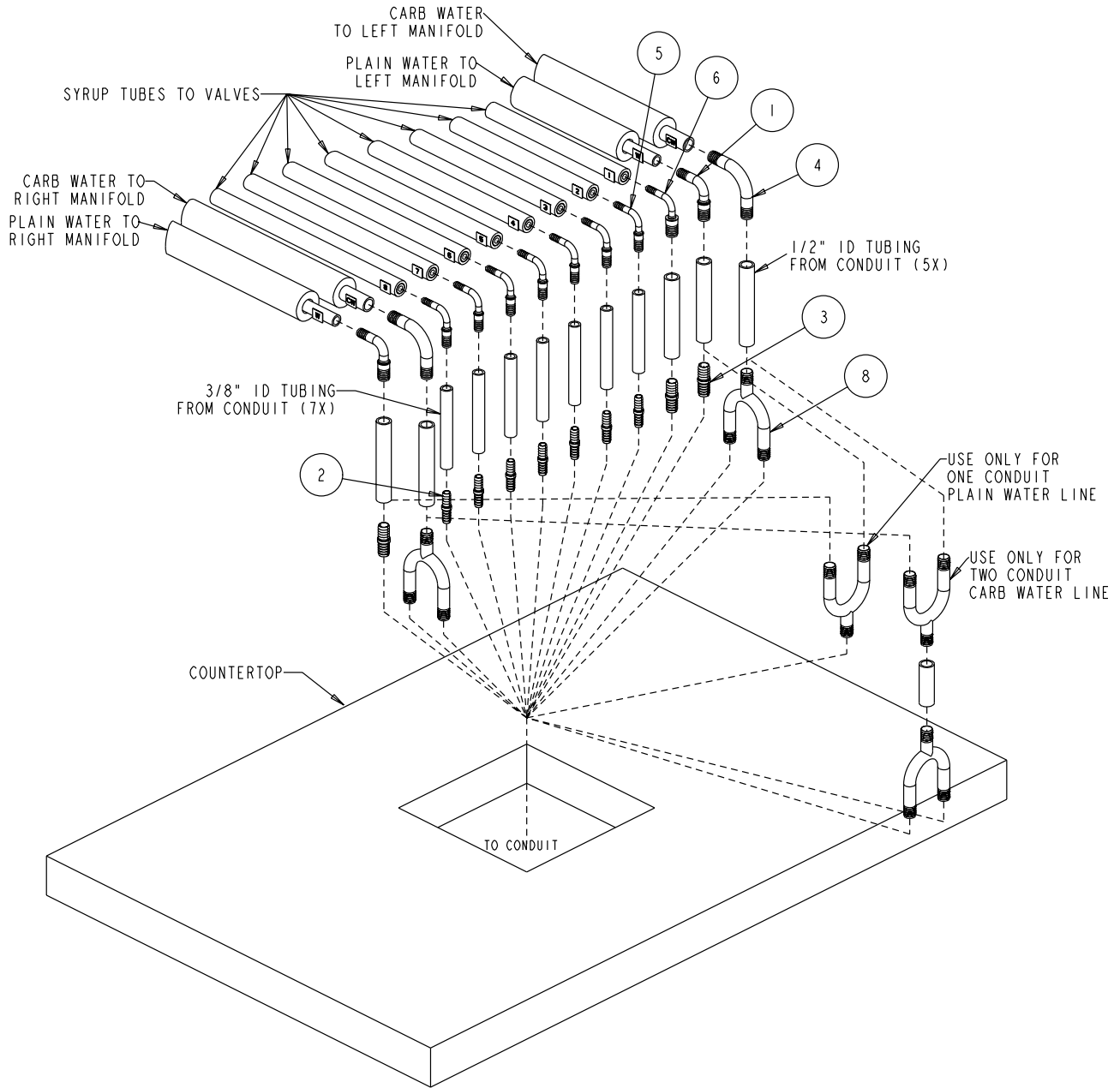

No.	Part Number	Description	Qty.
1	00854998	ELL 1/2 X 3/8 BARB SS	2
2	00861304	SPLICER 3/8 X 3/8 BARB	7
3	00861306	SPLICER 1/2 X 1/2 BARB	3
4	5018595	SPLICER ELBOW SS 1/2 X 1/2	2
5	5030996	ELBOW 1/4 X 3/8 BARB SS	7
6	5030997	ELBOW 1/4 X 1/2 BARB SS	1
7	5030998	U-BEND 1/2X1/2 WI-1/2STEM	3

# INSTALLATION

## MII-302 INSTALLATION KIT

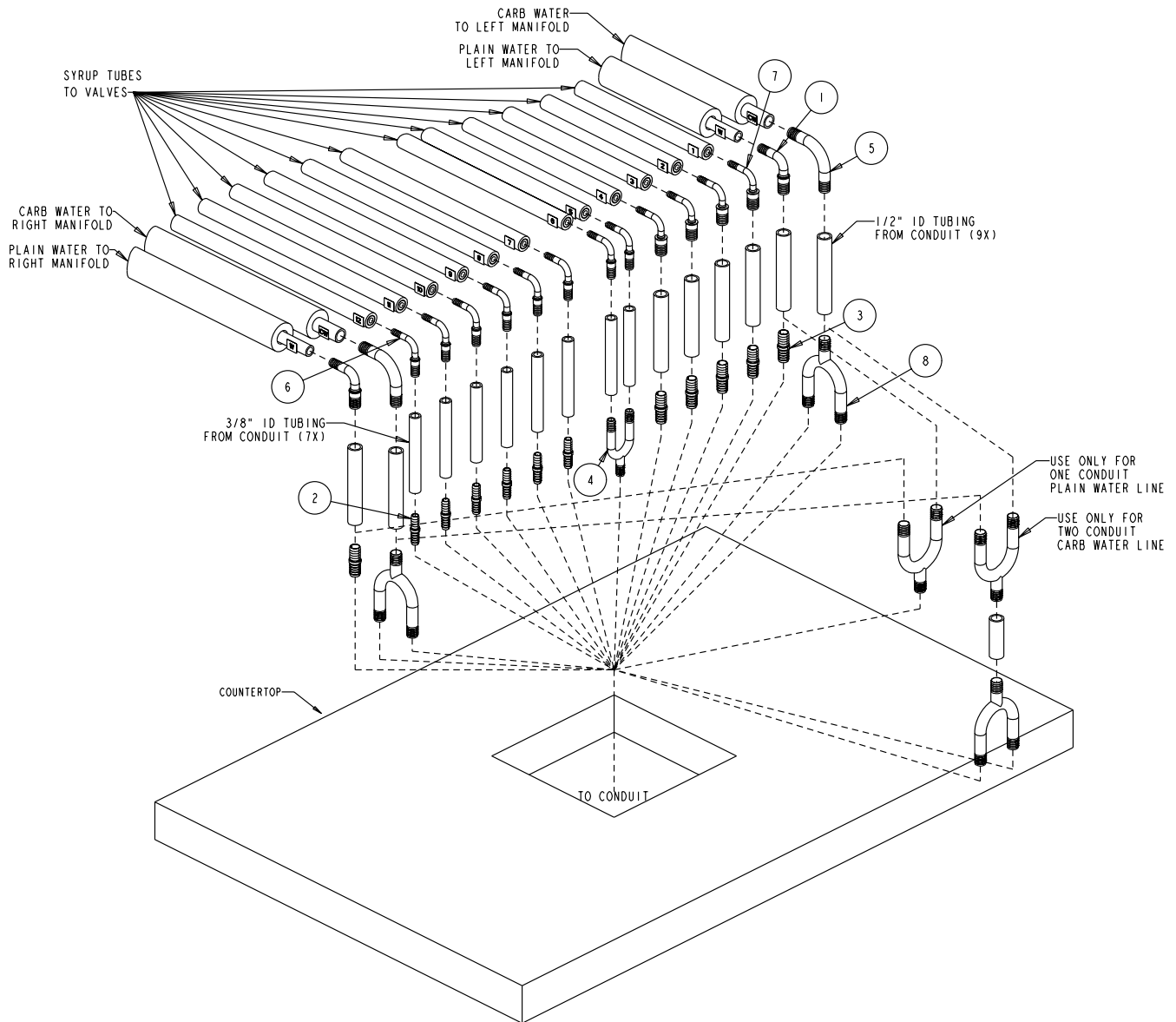

No.	Part Number	Description	Qty.
1	00854998	ELL 1/2 X 3/8 BARB SS	2
2	00861304	SPLICER 3/8 X 3/8 BARB	6
3	00861306	SPLICER 1/2 X 1/2 BARB	6
4	5011751	FITTING 3/8" Y BARB	1
5	5018595	SPLICER ELBOW SS 1/2 X 1/2	2
6	5030996	ELBOW 1/4 X 3/8 BARB SS	8
7	5030997	ELBOW 1/4 X 1/2 BARB SS	4
8	5030998	U-BEND 1/2X1/2 WI-1/2STEM	3

# INSTALLATION

## WATER & SYRUP LINES

This kit facilitates connecting the unit to a 12-16 line conduit, with one or two carbonated water recirculating systems, and one or two plain water supply lines, and maximum 8 syrup product lines.

The Unit is shipped with connecting lines terminating under the unit. It will be necessary to make a 90° turn down through the counter top, to connect to the conduit. It will also be necessary to fully insulate this new added section before passing through the counter top, or before hooking to main conduit.

### CARB WATER LINES:

- Unit has two (2) carb water lines, one for each flex manifold.
- Use 2 @ ½" x ½" elbow and 6-12" of ½" conduit tubing to make connection bend from unit down through hole in counter top, to mate with conduit.
- Conduit with only two (2) circulating carb water lines
- Use 2 @ ½" barb U-Bend adaptors (invert one) to connect the two carb circulating lines from conduit to the two carb water lines from the unit. Use short ½" conduit line to connect the two U-bends as shown (option to 8).
- Conduit with four (4), two sets of recirculating carb water lines
- Use 2 @ ½" barb U-Bend adaptors, to connect each set of circulating conduit lines to each carb water line from unit as shown (8) .

### PLAIN WATER LINES:

- Unit has two (2) plain water lines, one for each flex manifold.
- Use 2 @ 3/8" x 1/2" elbows and 6-12" of 1/2" conduit tubing to make connection bend from unit down through hole in counter top, to mate with conduit.
- Conduit with only one (1) plain water line
- Use 1 @ ½" U-bend adaptor, to connect the two plain water lines to one plain water line from conduit (option to 3.)
- Conduit has two (2) plain water lines
- Use 2 @ ½" straight adaptors to connect each plain water line from unit to each plain water line from conduit as shown (3.)

### SYRUP LINES:

- Unit has eight (8) syrup lines
- Use 7 @ ¼ x 3/8" and 1 @ ¼ x ½" elbows and proper size conduit tubing to make connection bend from unit down through hole in counter top, to mate with conduit.
- FULLY INSULATE (no air gaps) and finish with tape wrap, all these connections from unit, through 90° bend connection and down close to straight conduit connection. Locate Unit properly on counter, and secure to counter as shown in Unit Installation Instructions. Finish connections to Conduit with 3/8" x 3.8" and ½" x ½" straight barb connectors, and U-bend adaptors, as needed.
- FULLY INSULATE and finish with tape wrap, all these connections to the conduit.

# INSTALLATION

## DRAINAGE OPTIONS

The drains for MII Series connects to the drain pan.

### Option One

Drainage through the bottom of the unit:

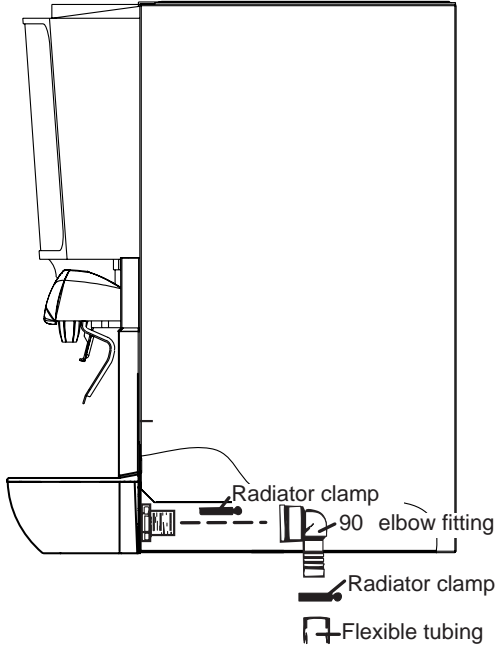

### Option Two

Drainage through the back of the unit:

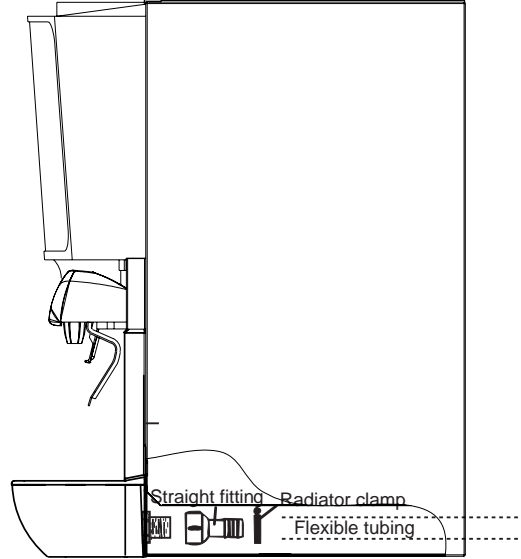

### Drain with Extended Splash Panel

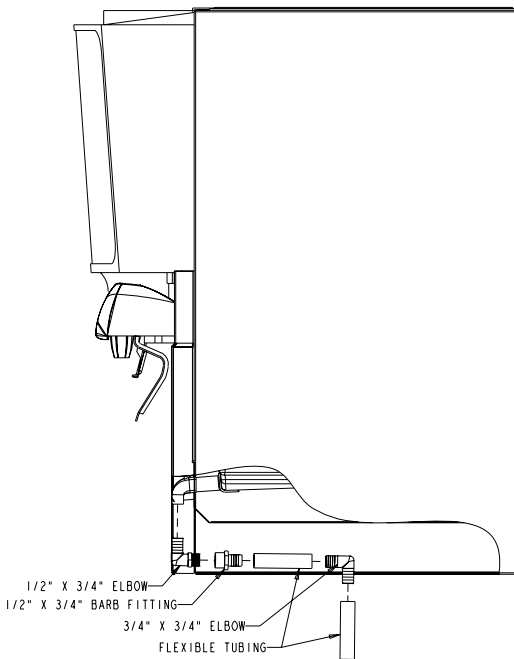

### Rear of Unit

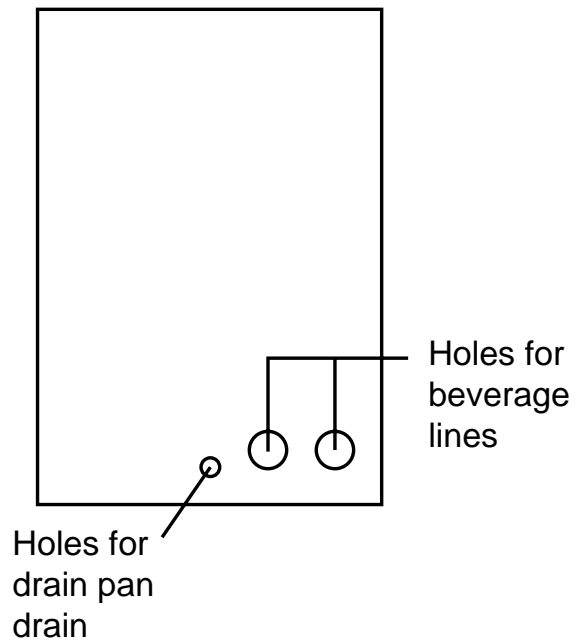



# INSTALLATION

## TOP MOUNTED ICEMAKER REQUIREMENTS

- 1 Location** - Avoid placing the dispenser and/or ice machine near heat sources such as radiators, ovens, refrigeration equipment and direct sunlight.
- 2 Clearances** - Six inch (15.2 cm) clearance on all sides of the icemaker is needed.
- 3 Front of icemaker to be flush with front of dispenser**- The front of the icemaker should be flush with the front of the dispenser, as shown in the drawing above. Because the icemaker is flush with the

front of the dispenser, some icemakers may overhang at the back of the dispenser.

- 4 Drains** - A separate drain line is required for the ice machine, in addition to a drain line for the ice/beverage dispenser.
- 5 MII Series dispensers require an adapter kit to install some top-mounted icemakers.** Contact your local Multiplex distributor for the correct adapter kit.

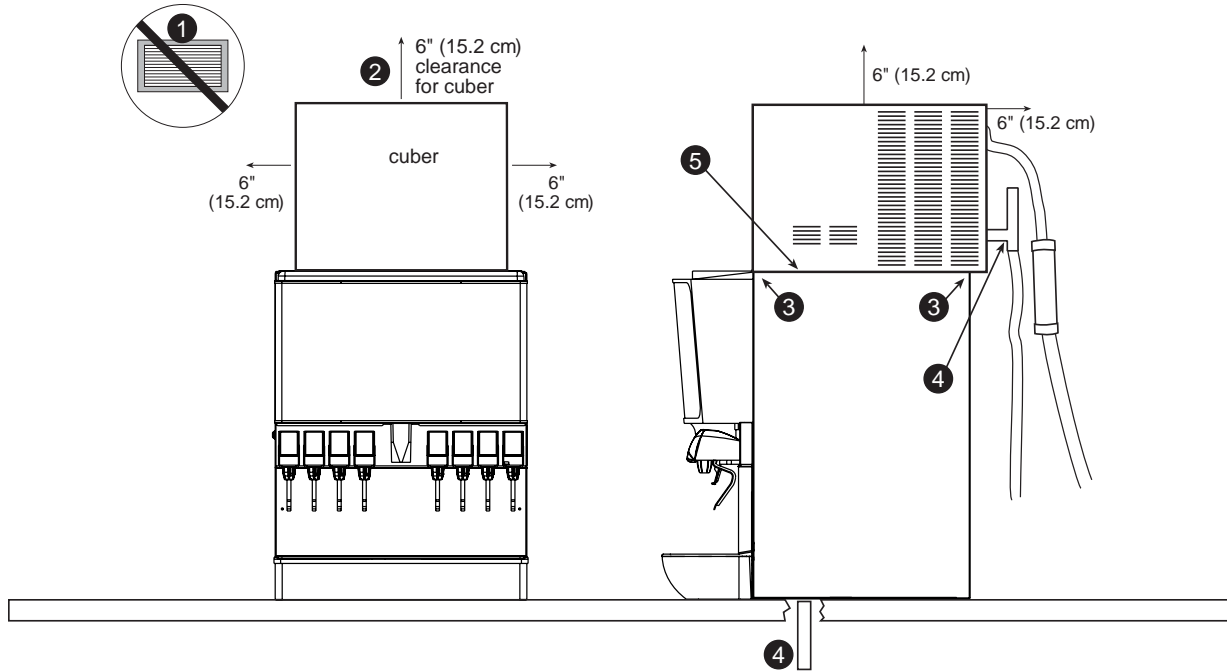

**NOTE:** For full information about icemaker installation, including plumbing lines connections and electrical requirements, see the icemaker installation manual.

## ICE FLOW RESTRICTOR



Ice Flow Restrictor

For all MII, MD and MDH Series dispensers an Ice flow restrictor is available. This ice flow restrictor decreases the amount of ice allowed to enter the ice chute by blocking a small area at the entrance of the dispenser chute. This in turn restricts the flow of ice that is dispensed in to your cup.

Please refer to the instructions included in kit #[5013822](#) for more information on how to install.

# INSTALLATION

## ROCKING CHUTE ICE DELIVERY SWITCH ADJUSTMENT

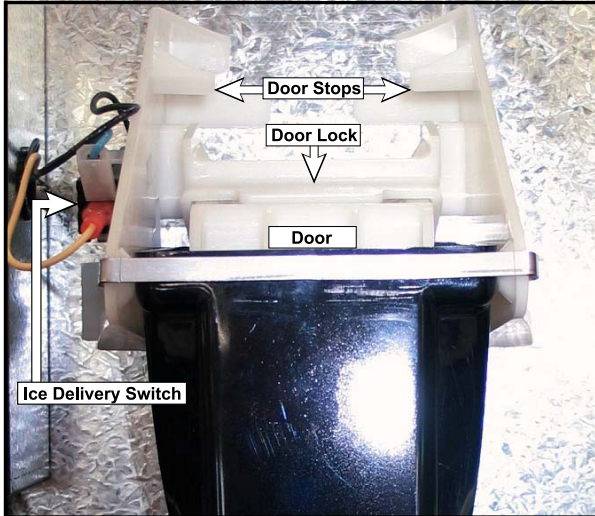

① To properly adjust the switch, first unplug the power cord to the unit then remove the merchandiser. This will give you access to the ice delivery switch located on the left side of the rocking chute.

② Begin by observing the chute by slowly pushing against the rocking chute. When the ice delivery switch clicks, measure the distance from the door stops on the rocking chute bracket to the door. The distance between the two should be no more than 1/4", but no less than 1/16".

③ The left side of the rocking chute has a tab that pushes up on the ice delivery switch. To adjust it, use needle nose pliers and bend the arm of the switch up or down in order to change the point where the tab makes contact with the switch arm.

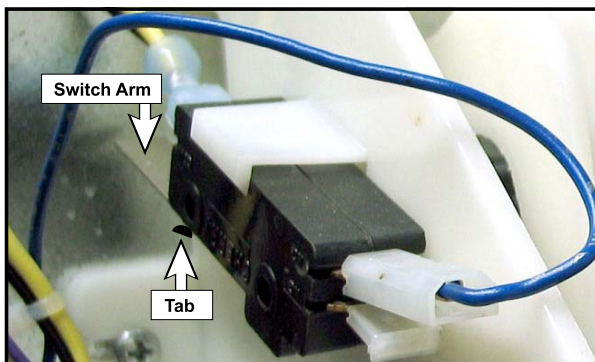
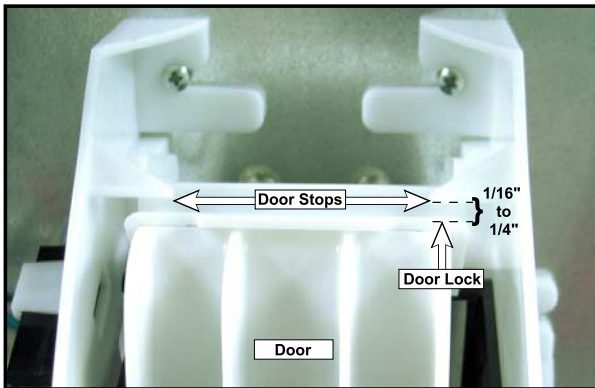

# INSTALLATION

## BAFFLE FOR MANITOWOC™ CUBERS

When installing a Manitowoc™ “S” series Ice Machine on a MII dispenser, a baffle kit is required for proper installation. The baffle kit is designed to prevent ice from lying against the front of the ice machine, and melting down the front of the dispenser. There are two different baffle kits available, one kit is for the 30" wide “S” series ice machine, and the other kit is for the 22" wide “S” series ice machine.

These two Kits are available through your local Manitowoc Distributor. List prices may be subject to change without notification. Please call your local parts distributor for current pricing before ordering.

### Ice Maker Baffle Installation:

1. Remove both front panels.
2. Examine the ice machine to see if the machine has four screws on the lower front plastic panels.
3. If there are screws, remove them from the countersunk holes on the front surface of the machine, save the screws.
4. Install the deflector, using the four screws removed in step three.
5. Four screws and two backing plates are in the kit.
6. If there are no screws on the ice machine (step 2), pierce the thin plastic countersunk holes, install the backing plates and install the deflector using the screws from the kit.
7. Replace the front panels.

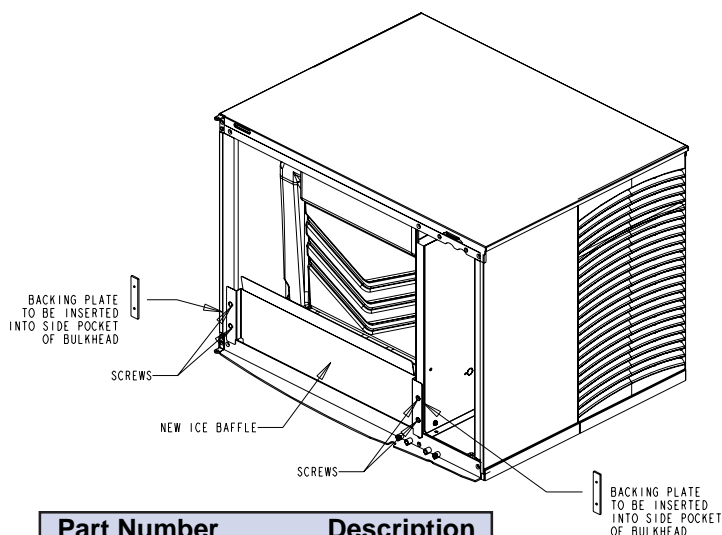

Part Number	Description
5029518	Baffle Kit 30"
5029517	Baffle Kit 22"

## BAFFLE FOR "Q" SERIES ICE MACHINES

1. Position baffle on top of water well with tab on the front and the other tab inside the water well.
2. Mount the baffle on the left side of the ice maker using the hole and screw provided.

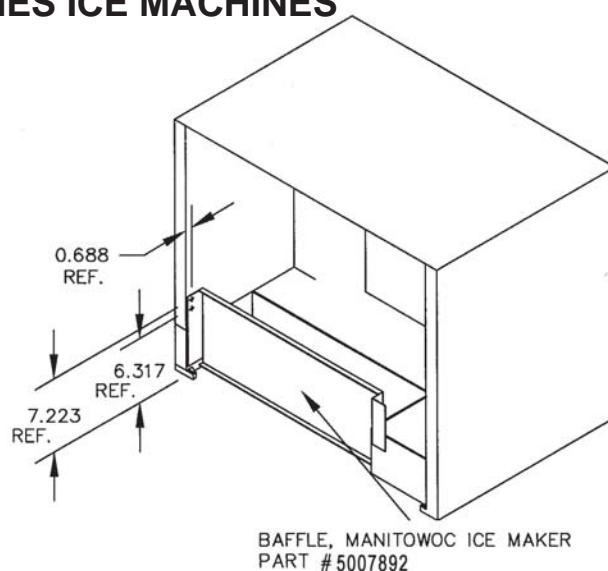

## MANUAL FILL LID FOR DISPENSERS WITH A CUBER

If you are top mounting your MII Series dispenser with a cuber, you will require a lid for the manual fill area at the top, front of the dispenser.

If you ordered a dispenser and a cuber at the same time, the manual fill lid was included with the unit. The manual fill lid can be ordered from your local Multiplex distributor.

# INSTALLATION

## GENERAL INSTRUCTIONS FOR REMOVAL OF GEAR MOTOR

These instructions are provided as a guide for the removal of the gear motor. Depending on the model number of your dispenser, these instructions may vary slightly.

1. Disconnect power from the electric receptacle.
2. Remove all ice from the ice storage bin of the dispenser.
3. Remove the paddle wheel pin from the paddle wheel / agitator assembly inside the dispenser bin.
4. Remove the agitator assembly from the dispenser bin by pushing the agitator to the back of the bin. Angle the front of the agitator to the side. Pull the agitator forward then out of the dispenser.
5. Remove the paddle wheel from the dispenser by pulling the hub of the paddle wheel to the back of the bin and off the gear motor shaft.
6. Remove the splash panel from the dispenser and expose the gear motor.
7. Disconnect the electric connector from the gear motor wire leads.
8. Remove the pin in front of the gear motor.
9. You should be able to remove the gear motor from the dispenser.
10. To install a replacement gear motor, reverse this procedure.

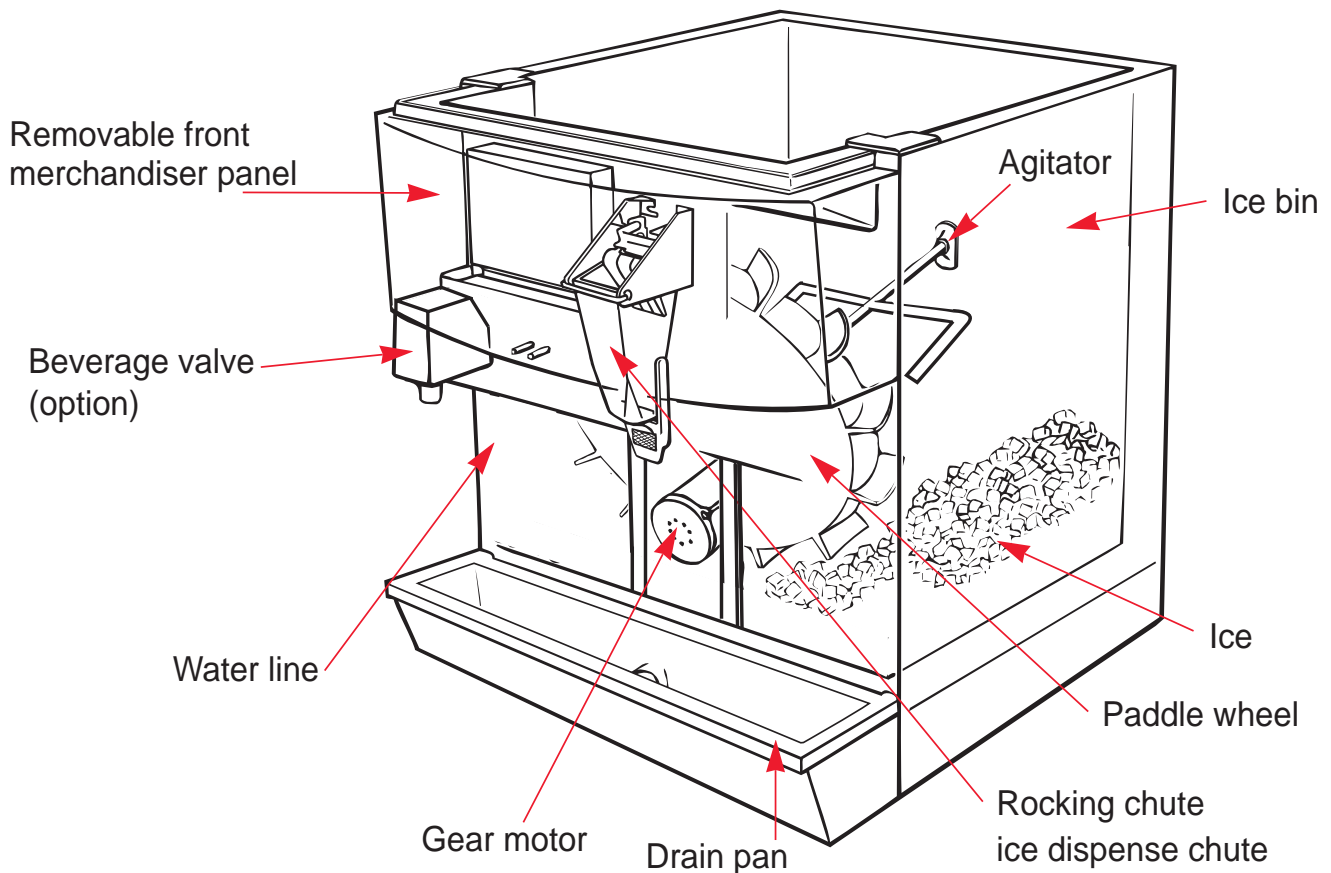

# INSTALLATION

## MII-250 PLUMBING DIAGRAM

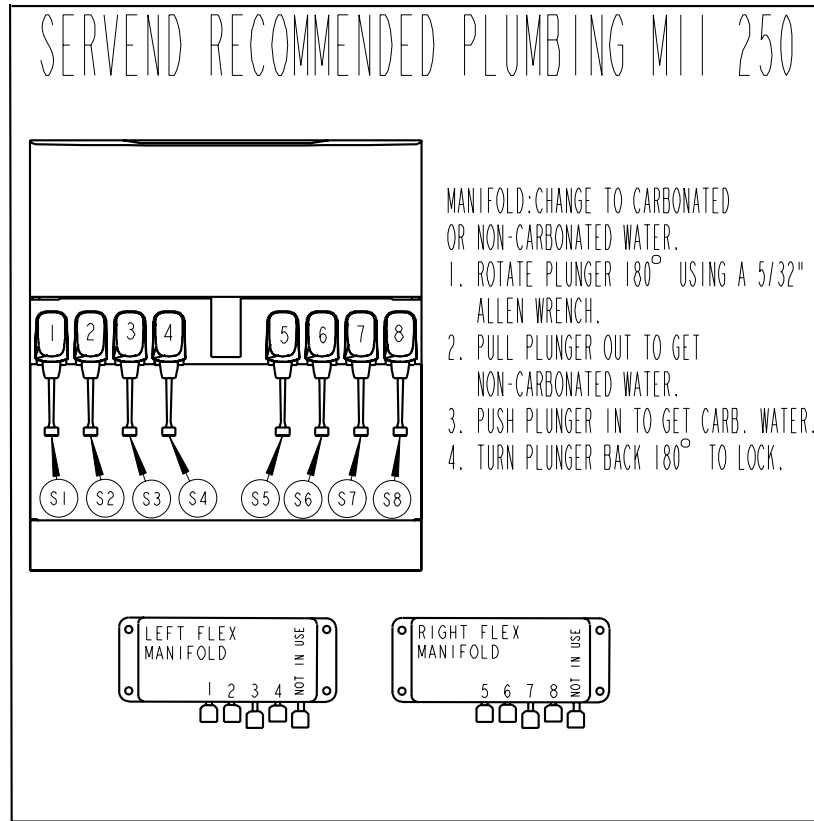

## MII-302 PLUMBING DIAGRAM

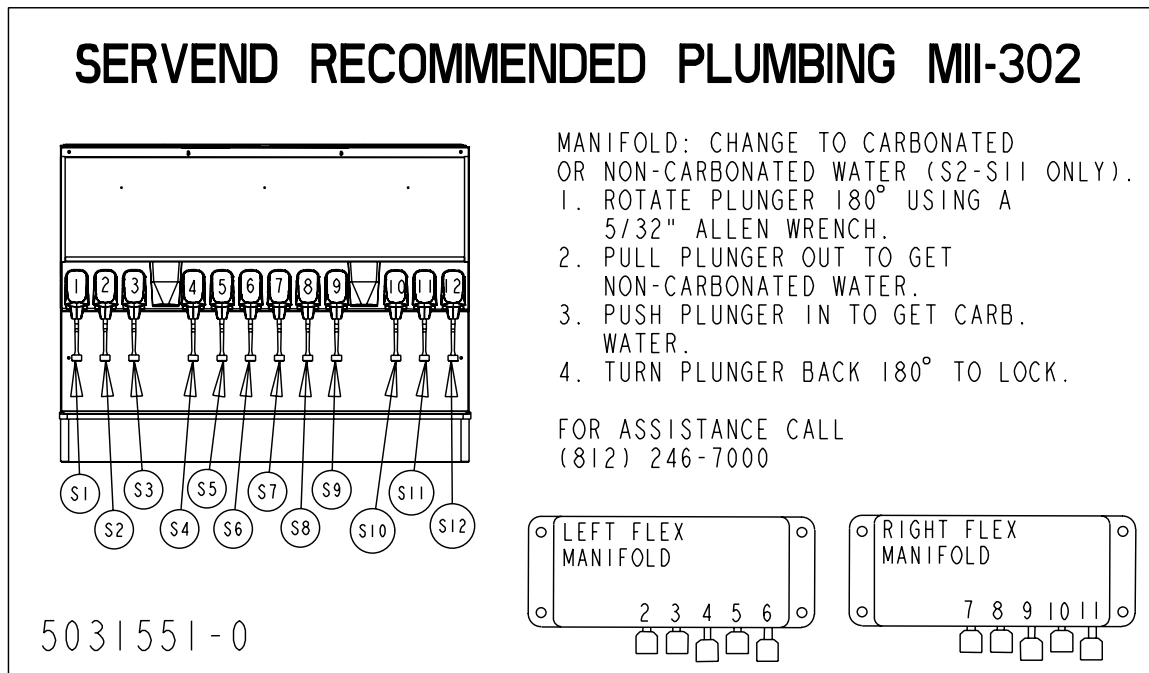

# OPERATION

## UNIT INSPECTION

Thoroughly inspect the unit upon delivery. Immediately report any damage that occurred during transportation to the delivery carrier. Request a written inspection report from a claims inspector to document any necessary claim.

### ICE RECOMMENDED FOR DISPENSING

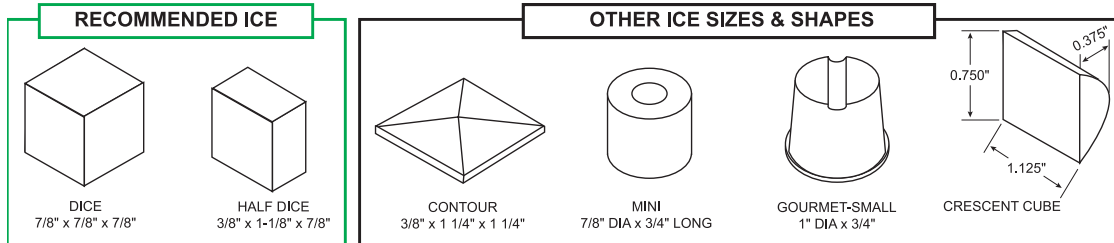

MII dispensers are designed to dispense hard, cube ice up to one-inch square. The ice shapes and sizes listed above are recommended for dispensing. **Warm “Super Cooled” Ice Before Dispensing** “Super Cooled” ice is not recommended for dispensing. “Super cooled” ice is ice that has been stored in freezers below 32°F. Should it be necessary to temporarily use “super cooled” ice, allow the ice to warm at room temperature for 25 to 30 minutes before placing the ice in the dispenser.

### ICE STORAGE AND DISPENSING

As the customer presses the rocking chute, the arm at the top left rear of the chute pushes upward on the door lock. The door opens until it contacts the stops in the mounting brackets. The plastic arm on the ice chute also activates the lever of the ice dispensing switch. When activated, the micro switch starts the gear motor. The gear motor turns the paddle wheel and agitator arm.

The paddlewheel carries ice. Periodic agitation is optional on the MII-150 and MII-175 and is standard on the MII-200, MII-250, MII-302 and MII-402. During periodic agitation, the paddle wheel and agitator turn for approximately three seconds every three and one half-hours. The door lock prevents ice from being dispensed during the agitation cycle.

### BEVERAGE VALVES

Post-mix beverage valves are designed to precisely meter the flow of both water and syrup to obtain the proper mixing ratio. The syrup and soda water components of the post-mix beverage are mixed as they leave the beverage valve.

### ROCKING CHUTE ICE DISPENSING

As the customer presses the rocking chute, the arm at the top left rear of the chute pushes upward on the door lock. The door opens until it contacts the stops in the mounting brackets. The plastic arm on the ice chute also activates the lever of the ice dispensing switch. When activated, the micro switch starts the gear motor. The gear motor turns the paddle wheel and agitator bar.

### LEGS

Legs are optional equipment with most MBE dispensers. Standard legs are four-inch (10.2 cm) tall stainless steel legs. MII 302 and MII 402 cannot be placed on legs. When installing legs on a MII Series dispenser, leg braces should be used. These are metal braces fitting side to side under the dispenser that reinforce the leg attachment area. It is recommended if an icemaker is installed on top of the dispenser, legs should not be installed.

# OPERATION

## MII-250 MEASUREMENTS & SPECIFICATIONS

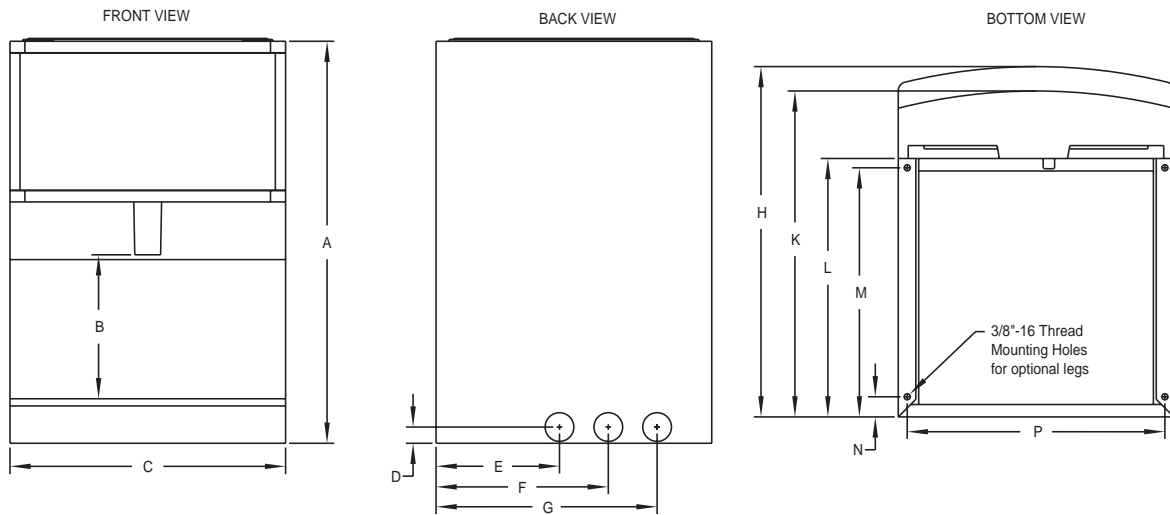

Unit	A	B	C	D	E	F	G	H	K	L	M	N	P
MII-250	39"	12.5"	30"	1.5"	9.938"	13.5"	20"	30.5"	28.375"	22.5"	21.688"	1.75"	28.438"

MII-250	
<b>Standard Features</b>	Lighted Merchandiser, "ice" graphics, key switch, stainless steel legs, drain kit, Lighted Merchandiser, "ice" graphics, key switch, stainless steel legs, drain kit,
<b>Dimensions</b>	30" W x 30.5" D x 39"H (add 1.25 to height for lid)
<b>Shipping Weights</b>	199 lbs./90.5 kgs
<b>Countertop Weights</b>	175 lbs./79.5 kgs
<b>Ice Storage Capacity</b>	up to 250 lbs./ 114 kgs.of ice.
<b>Electrical Requirements</b>	Dispenses: 120V/60Hz/2.8 FLA Dispenses: 120V/60Hz/2.8 FLA
<b>Drain</b>	Two 3/4" (1.96cm) PVC (N.P.T.) drain fittings, (one pre-installed 3/4" (1.96cm) PVC fitting extends from drain pan. A second fitting extends from bin.)
<b>Machine Compatibility</b>	Manual fill or top-mount with compatible 22" and 30" wide ice machines. Contact factory for baffle and ice wide ice machines. Contact factory for baffle and ice
<b>Graphic Area Dimensions</b>	Physical trim: 29.5"W x 16.625"H 74.93W x 42.228H (cm) Visual area: 28.5"W x 15.625"H 72.39W x 39.688H (cm)
<b>Service</b>	Motor, drain and electrical connections are front serviceable.
<b>Options</b>	Wilshire FFV standard beverage valves (other valves also available), extended splash panel, splash guards, adapter kits for top-mounted ice machine applications.

# OPERATION

## MII-302 MEASUREMENTS & SPECIFICATIONS

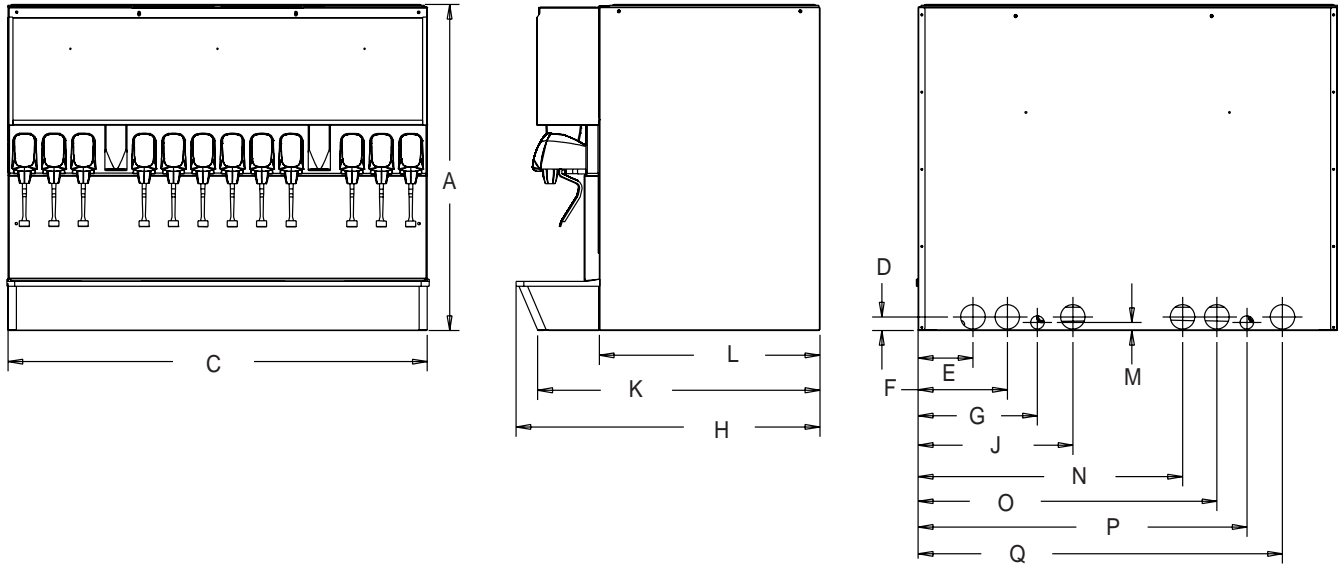

Unit	A	B	C	D	E	F	G	H	J	K	L	M	N	O	P	Q
<b>MII-302</b>	33.25"	12.50"	42.75"	1.38"	5.59"	9.10"	12.16"	31.00"	15.78"	28.78"	22.50"	.82"	26.97"	30.47"	33.75"	37.16"

<b>MII-302</b>	
<b>Standard Features</b>	Key Switch, Drain Kits, 12" high lighted merchandiser and timed agitation
<b>Dimensions</b>	42.75" W x 31" D x 34.25" H (inches) 108.6 W x 78.74 D x 87 H (cm)
<b>Shipping Weights</b>	470 lbs. / 213 kgs.
<b>Countertop Weights</b>	402 lbs. / 182 kgs.
<b>Ice Storage Capacity</b>	300 lbs. / 136 kgs.
<b>Electrical Requirements</b>	Dispenser: 120V/60Hz/3.5FLA
<b>Drain</b>	Two pre-installed 3/4" (1.9 cm) PVC (N.P.T.) drain fittings extends from drain pan. Ice bin drains directly into drain pan for front clean out, no hook up necessary.
<b>Machine Compatibility</b>	Manual fill or top-mount with compatible 30" wide ice machine. Certain top-mounted machines may reduce storage capacity. Contact distributor or MBS for baffle and ice maker lid requirements for top-mounted ice machine applications.
<b>Graphic Area Dimensions</b>	Standard Physical trim - 42.625" W x 11" H (108.2 W x 27.94 H (cm)) Visual area - 41.75" W x 10.062" H; (106 W x 25.56 H (cm)) Extended Merchandiser: Physical trim - 42.5" W x 23.813" H (107.95 W x 60.49 H (cm)) Visual area - 41.624" W x 22.875" H (105.72 W x 58.1 H (cm))
<b>Service</b>	Motor, drain and electrical connections are front serviceable.
<b>Options</b>	The MII-302 will accommodate up to 12 Flomatic 464 (at 3-4 oz/sec) beverage valves. F-464 valves are available in sanitary lever, push button, Autofill lever and portion control. Other valves available, contact factory for details. Leg kits not available for MDH-302. Other options: regulators, carbonator, side water lever installation kits and side splash panels.

# OPERATION

## MII-250 FOOTPRINT

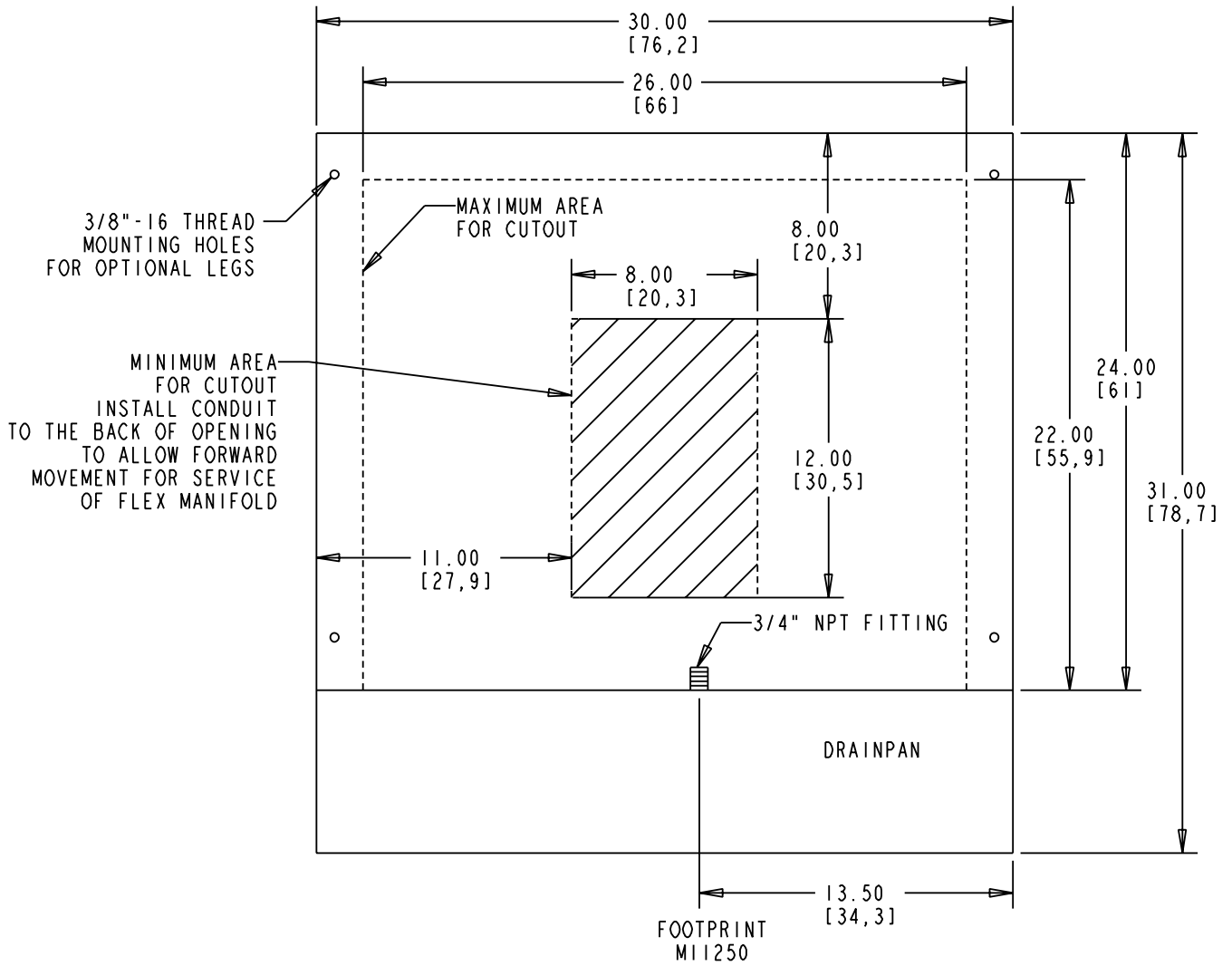

# OPERATION

## MII-302 FOOTPRINT

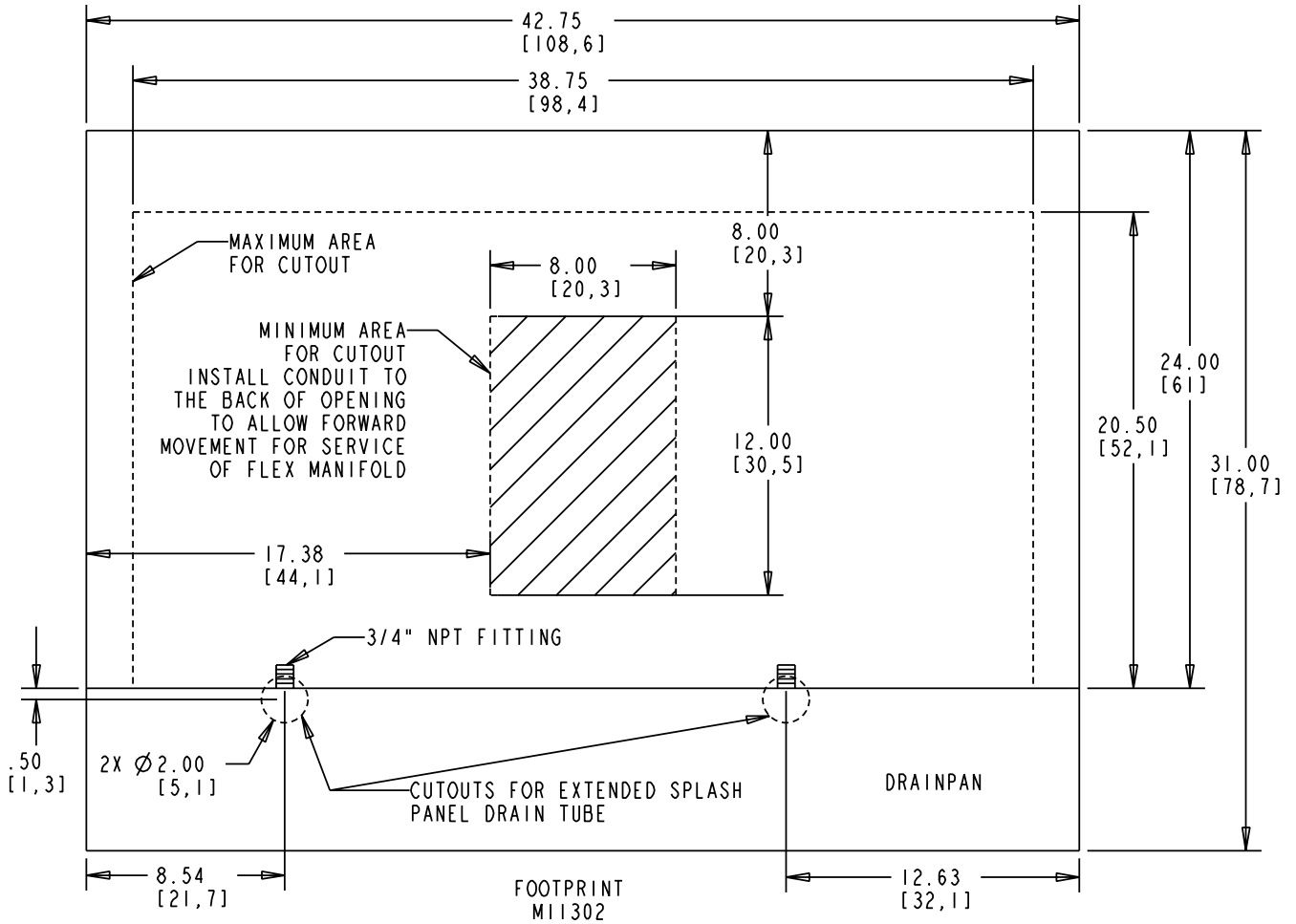

# OPERATION

## CARBONATION

The purpose of the carbonator is to take regular tap water at street water pressure (minimum 20 PSI dynamic or flowing pressure) 1/2" water line and increase the water to beverage system pressure (usually 100 PSI). This water is then combined with the CO<sub>2</sub> gas. Because the water and gas are at the same pressure, the CO<sub>2</sub> will dissolve into the water. Chilling the mixture before dispensing will assist in locking the carbon dioxide into the water. After dispensing, the CO<sub>2</sub> may be unlocked from the liquid. The CO<sub>2</sub> will gradually leave the liquid due to pressure and temperature changes.

### Components

The components of the carbonator are: water pump, an electric motor to operate the pump, carbonator tank where the water & CO<sub>2</sub> mix, and a water level control.

### Operation

Carbon Dioxide (CO<sub>2</sub>) leaves the storage tank and arrives at the carbonator tank through the gas inlet. Water supply enters the carbonator pump inlet at regular street water line pressure (minimum 20 PSI dynamic or flowing pressure). The water pump increases the pressure of the water, which allows the water to flow into the carbonator tank. The CO<sub>2</sub> and the water mix together in the

carbonator to produce the carbonated water that is then sent to the soda dispenser.

The agitation of the water & CO<sub>2</sub> together in the tank under high pressure creates the soda water. The quality of carbonation (percent of CO<sub>2</sub> mixed in the water) increases as the water temperature decreases and exposure time increases.

The water level in the carbonator tank is controlled by a water level control in the tank. This control turns the pump motor off and on to maintain a preset level of liquid in the tank. The water level control may be electronic probes or a mechanical float.

## SYRUP DELIVERY SYSTEM

Your syrup location can vary depending on the volume of beverages served and ease of accessibility. Your beverage system may set in a back storage room or under the counter of the dispenser. Configurations are almost limitless. Check the temperatures expected for the storage location. Adverse temperatures can affect the storage and quality of beverage products. It is recommended the temperature of storage location should not fall below 40° F or rise above 90° F.

## RACKING

Regardless if you are working on a B-I-B or Figal system, a place will be designated for placement of the product. A rack (or shelf) system affords systematic placement and complete usage of the beverage paid for. The B-I-B rack allows the boxes to lay properly for syrup dispersal. Please check with your B-I-B syrup supplier. Some boxes must be slightly tilted down, while others may be in virtually any position. The Figal tank rack keeps the newer and full tanks organized at one end of the beverage line with the partial tanks at the other.

## B-I-B

The Bag-In-Box system refers to a plastic disposable bag. The B-I-B normally contains 5 gallons of syrup, however some locations offer 2 1/2 gallon B-I-B units. This plastic bag is then held inside a cardboard or other container. B-I-B systems are for post-mix applications only.

## PUMPS

The syrup in a B-I-B system is delivered to the beverage system through gas operated pumps. These pumps extract the syrup out of the bags forcing the syrup throughout the system.

## AUTO BAG SELECTORS

These are used on higher volume B-I-B systems where two or more bags of the same product are connected to one pump and one system. An auto bag selector is essentially a valve that automatically changes from one bag (or series of bags) to another bag (or series of bags) of syrup as the bags empty, allowing a constant flow of product.

# OPERATION

## BACK ROOM PACKAGE

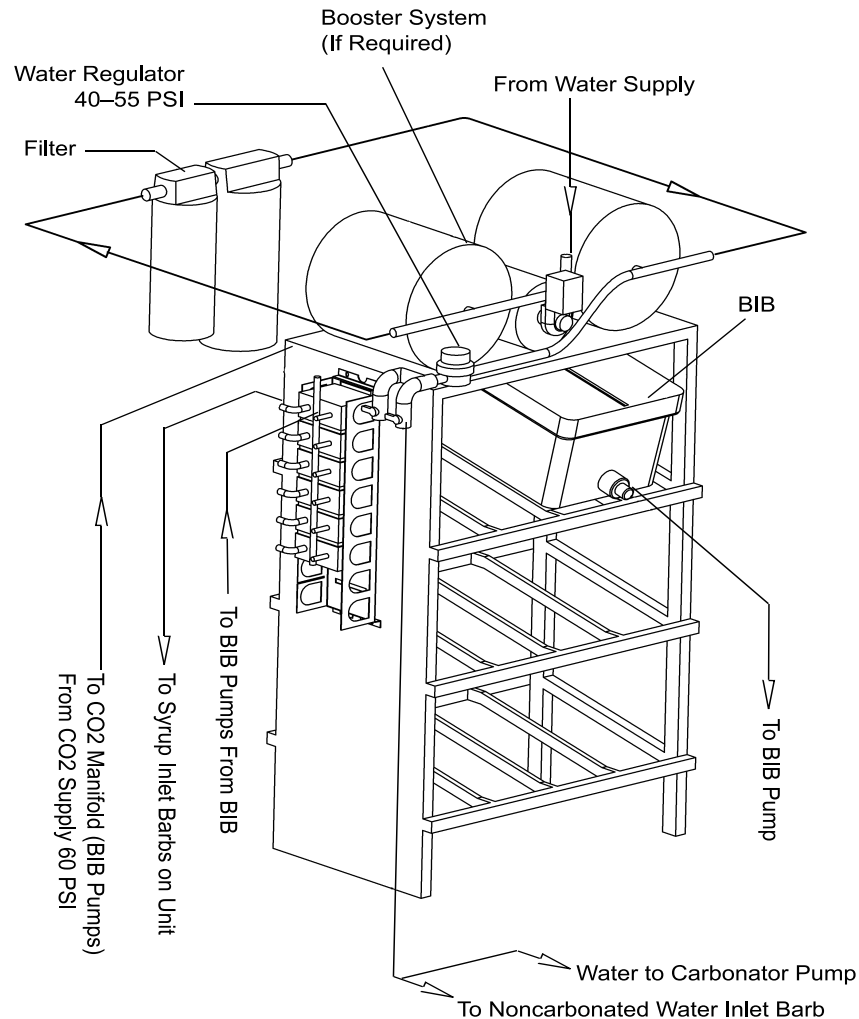

1. **Incoming tap water** - should be at a minimum dynamic pressure of 40 psi and maximum static pressure of 55 psi.
2. **Carbonator Water pump motor** - Powers the water pump. The water pump motor is part of the carbonator pump deck.
3. **Carbonator Water pump** - Pumps tap water into the carbonator tank. The water pump is part of the carbonator.
4. **Internal/External Carbonator tank** - Combines CO<sub>2</sub> gas and tap water to form carbonated water. The "carbonator" is the carbonator tank, water pump and water pump motor.
5. **CO<sub>2</sub> cylinder** - Holds highly pressurized carbon dioxide (CO<sub>2</sub>). The CO<sub>2</sub> cylinder is a steel or aluminum cylinder tank. CO<sub>2</sub> gas flows through the primary pressure regulator.
6. **BIB pressure gauge** - Set for a minimum of 60 psi. Indicates CO<sub>2</sub> pressure going to B-I-B pumps.
7. **Primary pressure regulator** - Lowers the CO<sub>2</sub> gas pressure, to 100 psi, so the CO<sub>2</sub> gas will be at the proper pressure to enter the carbonator regulator.
8. **Lowered outgoing pressure** - Set for 75 psi. Gauge indicated lowered outgoing pressure from the CO<sub>2</sub> cylinder after being routed through the primary pressure regulator at 100 psi..
9. **Secondary pressure regulator** - Lowers the CO<sub>2</sub> gas pressure before the CO<sub>2</sub> gas flows to the syrup pump. CO<sub>2</sub> pressure, activates the syrup pump.
10. **Syrup pump** - Draws syrup out of the bag-in-box syrup package. Syrup flows through the syrup lines to the dispenser for chilling, then dispensing. There is a syrup pump for each bag-in-box syrup system.
11. **Bag-In-Box syrup cartons** - Box which contains a plastic bag, filled with syrup.

# OPERATION

## 115V/220V NON ADJUSTABLE AGITATION TIMER

The agitation timer on this unit is equipped with test pins. This allows you to test the timer by removing the jumper between the two pins. When the jumper is removed the timer will cycle every 55 seconds if it is operating correctly. If the timer is wired correctly and does not cycle approximately every 55 seconds when the jumper is removed, replacement of the timer may be necessary. Make sure to replace the jumper pins when finished.

**NOTES:** This timer is re-settable, timed agitation every 3.5 hours from last dispense on power supply broken. Never operate in normal mode without test pins in place, damage could occur.

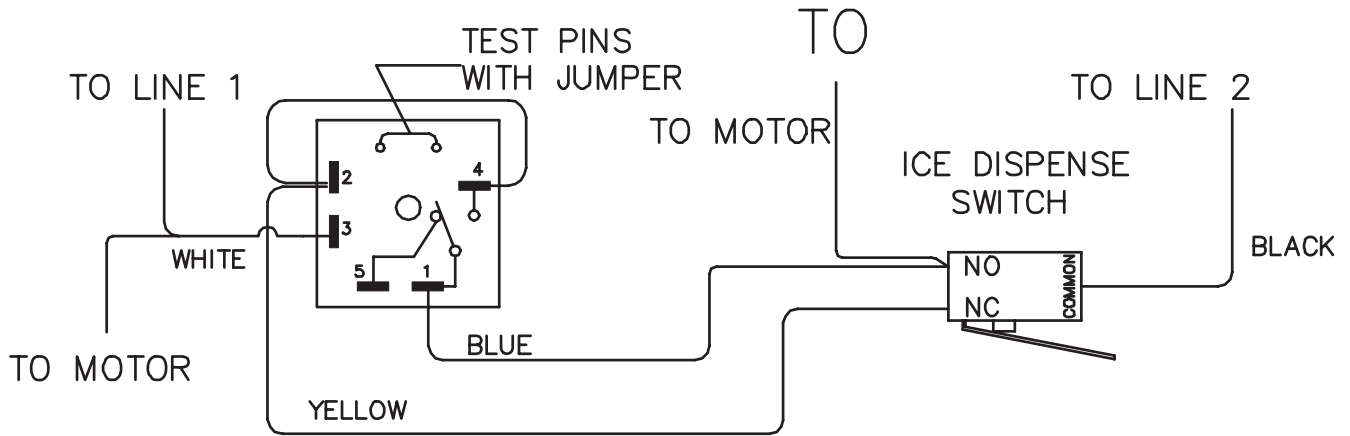

# USER MAINTENANCE

## PREVENTATIVE MAINTENANCE

Preventative maintenance is a vital part of keeping your MII dispenser in top condition. Following the guidelines below will assist you in continued trouble free operation of your unit.

1. Conduct daily maintenance of the machine.
2. Perform monthly maintenance of the machine.
3. Perform periodic maintenance and sanitizing of beverage system.
4. Do not overflow the dispenser bin with ice.
5. Do not allow the dispenser to sit for prolonged periods of non use with ice in the bin.
6. Most ice dispenser service problems are caused by low usage of the ice dispenser.
7. Do not allow ice to remain in the bin more than a day in order to prevent ice from freezing together and/or stagnant ice.

Possible excess ice storage reasons:

- Storage capacity exceeds daily requirements.
- Low demand during the off season.
- Dispenser oversized with future growth in mind.

Lower ice storage to meet one day's needs. If you manually fill ice, fill only with the appropriate amount of ice. Fill the dispenser with fresh ice each morning. Do not fill the dispenser at night just before shut down. Ice cubes can freeze together if not dispensed.

Contact MBE at 1-800-367-4233 for more information about our **ProActive Maintenance Program**.

## HOW TO DISASSEMBLE FOR CLEANING OR MAINTENANCE

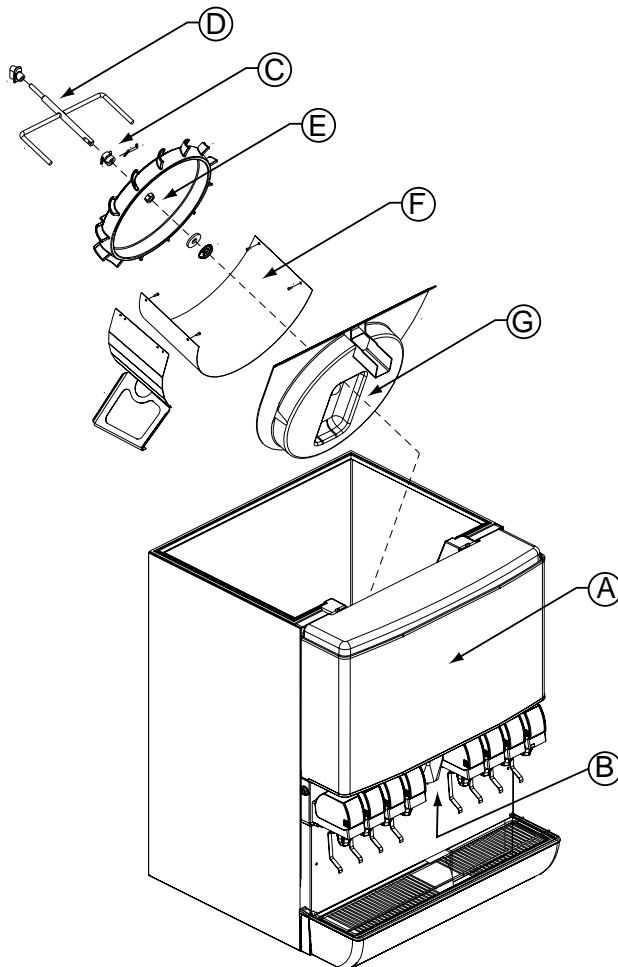
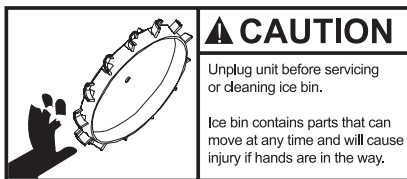

**NOTE: Sanitize the ice dispenser at Initial Start-UP in addition to monthly sanitizing. You will need screwdriver in order to disassemble.**

**Disassemble parts in the following order:**

- |                     |                        |
|---------------------|------------------------|
| A. Merchandiser     | E. Paddle wheel        |
| B. Ice chute        | F. Bin liner & Support |
| C. Paddle wheel pin | G. Paddle wheel Area   |
| D. Agitator         |                        |

**Accessing a Dispenser Bin Top Mounted with a Manitowoc Cuber:**

1. Remove the front panel of the ice machine.
2. Remove the ice deflection baffle. This will give you access to the dispenser bin.

**Accessing a Dispenser Bin that is Top Mounted with a Manitowoc Cuber and Large Extended Merchandiser in front of the Cuber:**

1. Access to the bin is possible through the strip lids on the side of the Dispenser.

**Disassembling the Dispenser Parts for Bin Cleaning:**

1. Remove the front panel of the Manitowoc ice maker.
2. If the Manitowoc ice maker is operating, wait for the sheet of ice to fall into the dispenser bin.

When the ice sheet falls into the dispenser bin, immediately place toggle switch of the ice machine to the "OFF" position.

If the Manitowoc ice maker is NOT operating, place the toggle switch of the ice machine to the "OFF" position.

3. On models without a top mounted cuber, remove the plastic lit from the top of the dispenser.
4. Remove all ice from the dispenser.
5. Disconnect electrical power to the dispenser.
6. On the MII-302 dispenser only, remove the strip lids off the top left and top right of the dispenser bin.
7. For the MII-302 dispenser only, there is a left bin and a right bin. Clean and sanitize one bin, then follow the same procedures on the second bin.

# USER MAINTENANCE

## HOW TO DISASSEMBLE FOR CLEANING OR MAINTENANCE

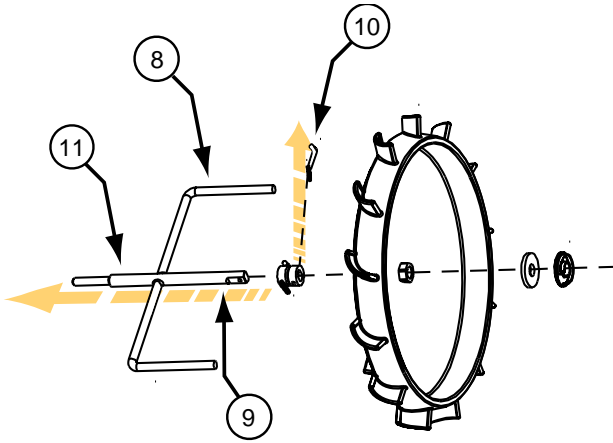

### Agitator arm and paddlewheel pin:

8. Rotate the agitator arm so the paddle wheel pin handle is pointing up, toward the ceiling.
9. Prepare agitator pin for removal by removing the stainless steel split ring.
10. Then remove the paddle wheel pin from the hole in the agitator.
11. Push the agitator bar toward the back of the unit until the agitator is free of the paddle wheel hub.

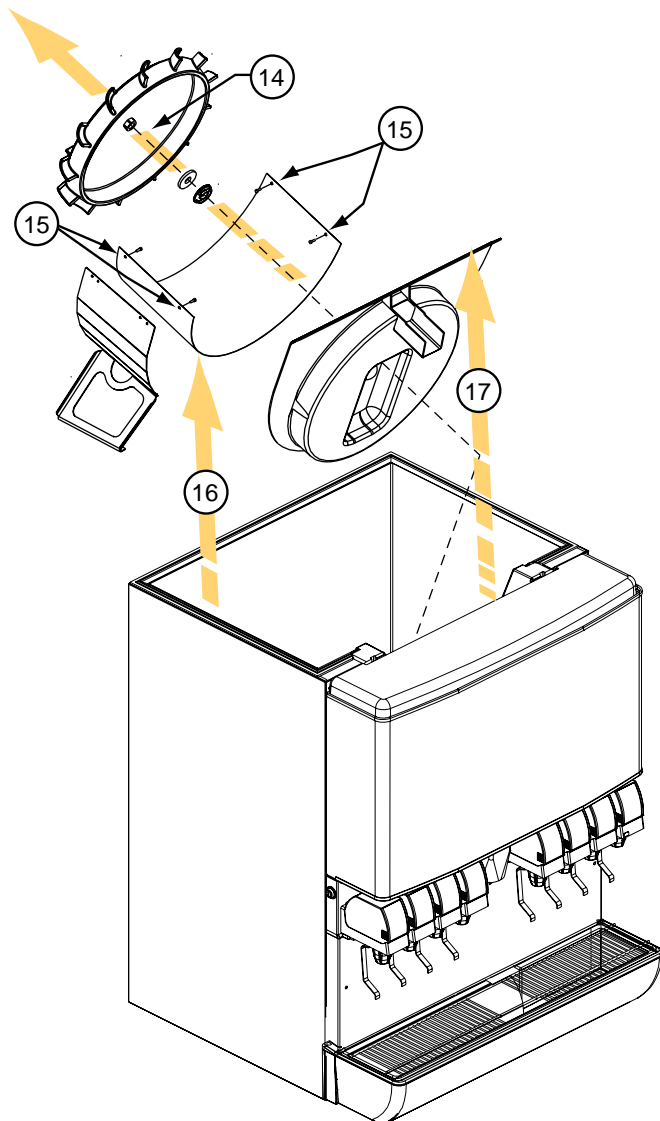

### Paddlewheel, bin liner and paddle wheel area:

12. Move the front of the agitator to one side and slide the agitator forward until the rear of the agitator shaft is clear of the bushing.
13. Remove the agitator from the bin area.
14. Slide the paddle wheel from its shaft.
15. Loosen the four knurled fasteners that hold the bin liner in place.
16. Remove the bin liner.
17. Remove the paddle wheel area from the bin.
18. Discard the remaining ice in the bin.

# USER MAINTENANCE

## HOW TO DISASSEMBLE FOR CLEANING OR MAINTENANCE

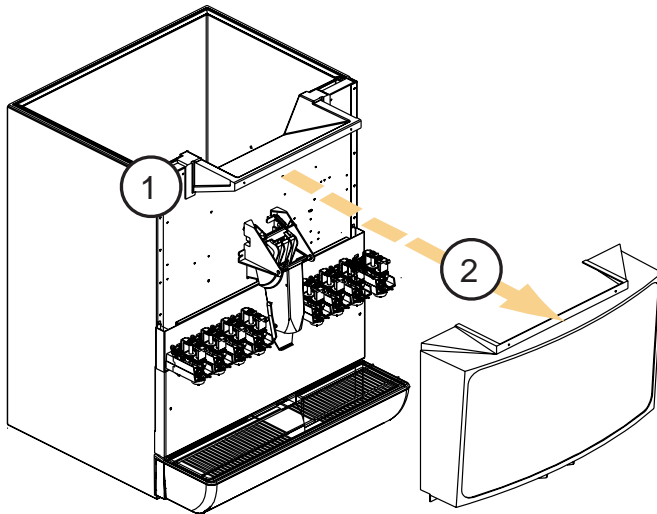

### Disassemble the rocking chute:

1. Loosen the two knurled fasteners that hold the merchandiser in place.
2. Remove the merchandiser.
3. Remove outer bracket.
4. Remove door lock.
5. Remove door.
6. Remove ice chute.

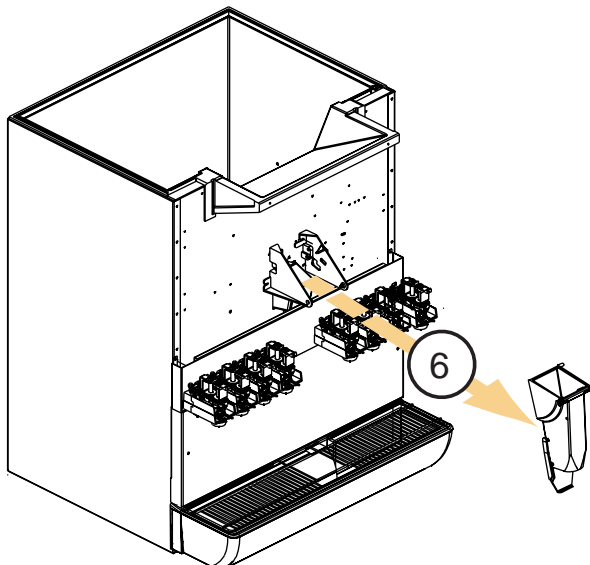
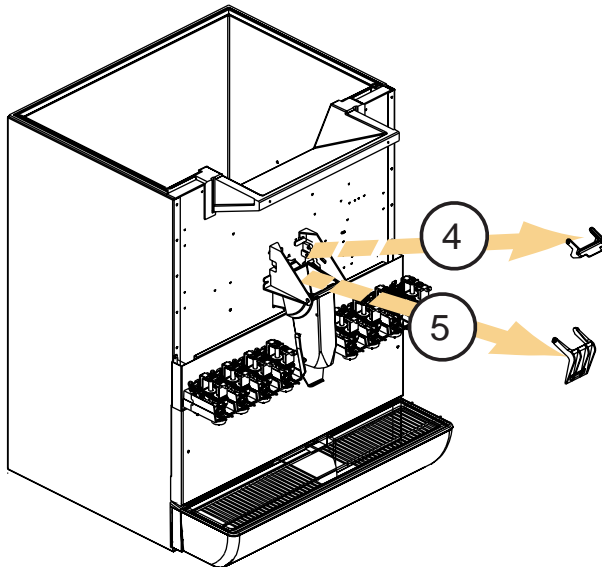

# USER MAINTENANCE

## DAILY CLEANING

All cleaning must meet your local health department regulations. The following cleaning instructions are provided as a guide.



**CAUTION:** Use only warm soapy water to clean the exterior of the tower. Do not use solvents or other cleaning agents. *Do not pour hot coffee into the drain pan. Pouring hot coffee down the drain pan can eventually crack the drain pan, especially if the drain pan is cold or still contains ice.*

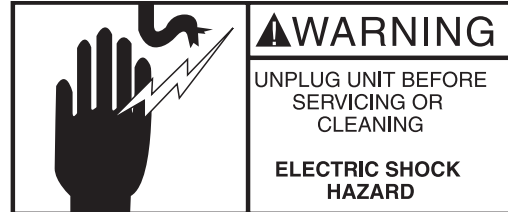
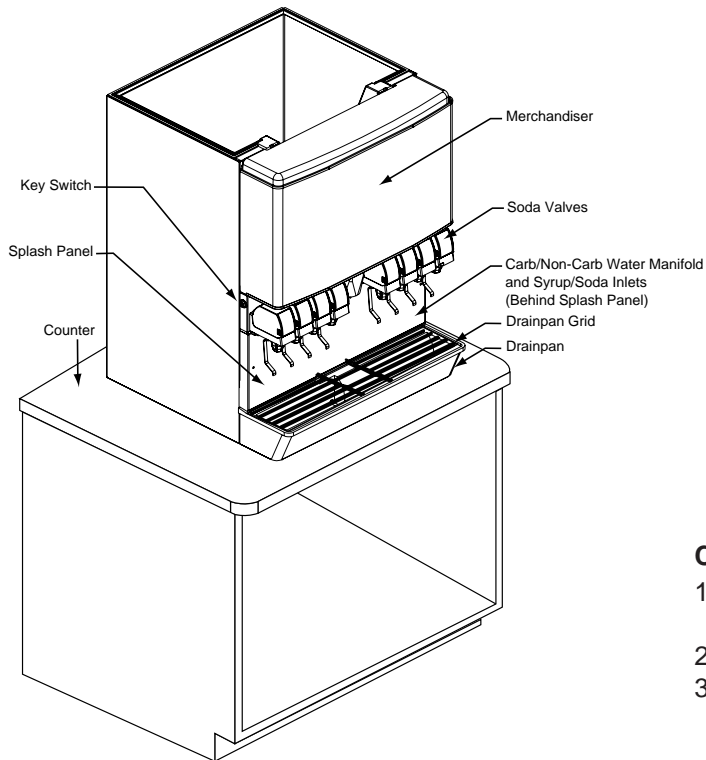

### Clean the exterior and drain pan:

1. Turn off the key switch located on either right or left side of the unit.
2. Lift the grid and remove it from the drain pan.
3. Using mild soap, warm water and a clean cloth, wipe the drain pan and splash panel. Then, rinse with clean, warm water. Allow plenty of warm (not hot) water to run down the drain of the drain pan, to remove syrup residue that can clog the drain opening.
4. Wash the grid, then rinse with clean water. Place the grid back in the drain pan.
5. Wash all exterior surfaces of the unit with warm water and a clean cloth. Wipe again with a clean, dry cloth.

### Clean the dispensing valves:

6. Remove nozzles and diffusers from beverage valves.
7. Rinse nozzle and diffuser with warm, clean water.
8. Clean nozzles and diffusers with soapy water and a soft bristle brush.
9. Clean the underside of the beverage valves with warm, soapy water. Rinse with clean damp towel.
10. Replace nozzles and diffusers on valves.
11. Turn on the key switch.

# USER MAINTENANCE

## MONTHLY CLEANING

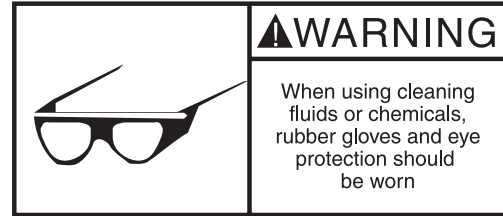
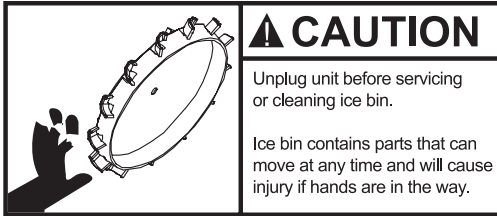

### Clean and sanitize the ice bin:

1. Unplug unit and remove all ice from the ice bin.
2. Mix a solution of mild detergent to clean the dispenser bin and components.
3. Wash the ice bin using a sponge and the mild detergent solution.
4. Using the mild detergent solution and a soft bristle brush or clean cloth, clean the following dispenser parts:
  - Entire bin
  - Paddle wheel
  - Paddle wheel area
  - Agitator
  - Paddle wheel pin
  - Ice Chute
  - Rear bushing
  - Motor shaft
  - Strip lids (where applicable)
5. Rinse all the parts in clean, running water.
6. Prepare 2 gallons of sanitizing solution by mixing a 1/2 ounce of household bleach (that contains 5.25% sodium hypochlorite) with 2 gallons of 120°F water. The mixture should not exceed 100 PPM of chlorine. Or mix a solution of any approved sanitizer, following the directions for mixing and applying the sanitizer..
7. Sanitize the ice bin and cold plate with the sanitizing

solution for at least 10 seconds.

8. Allow to air dry. Do not rinse.

### Re-assembling the dispenser parts:

9. Re-assemble parts in the following order:
  - Bin liner
  - Paddle wheel
  - Agitator
  - Paddle wheel pin
  - Ice chute
  - Merchandiser
10. Hand tighten all knurled fasteners.
11. Pour in fresh, sanitary ice and replace the plastic lid on the top of the dispenser.
12. Plug in the unit's electrical cord.
13. Check for proper ice dispensing.

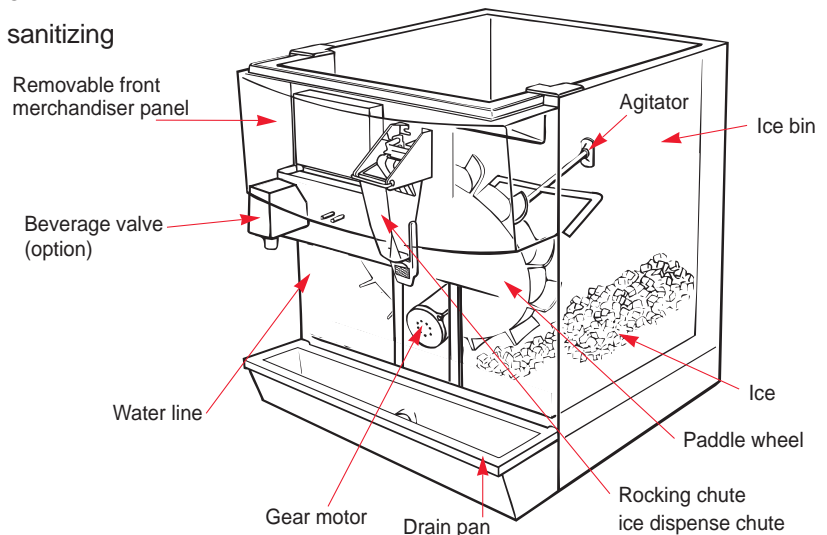

# USER MAINTENANCE

## BEVERAGE SYSTEM CLEANING

<b>▲ WARNING</b>
<p>Flush sanitizing solution from syrup system</p> <p>Residual sanitizing solution left in system could create a health hazard</p>

<b>▲ WARNING</b>	
	<p>When using cleaning fluids or chemicals, rubber gloves and eye protection should be worn</p>

Sanitize the beverage system at initial start-up as well as regularly scheduled cleaning. The drain pan must be in place under soda valves, to carry away detergent and sanitizing agents that will be flushed through valves.

## BAG-IN-BOX SYSTEM

The procedure below is for the sanitation of one syrup circuit at a time. Repeat to sanitize additional circuits.

You will need the following items to clean and sanitize the Bag-in-Box (BIB) beverage system:

- Three (3) clean buckets
- Plastic brush or soft cloth
- Mild detergent
- Unscented bleach (5% Na CL O) or Commercial sanitizer
- Bag-In-Box bag connector

1. Prepare the following in the buckets:
  - **Bucket 1** - warm to hot tap water for rinsing.
  - **Bucket 2** - mild detergent and warm to hot water.
  - **Bucket 3** - mix a solution of unscented bleach (5% Na CL O) or commercial sanitizer and warm to hot water. Mixture should supply 100 PPM available chlorine (1/4 oz. bleach to 1 gallon water).

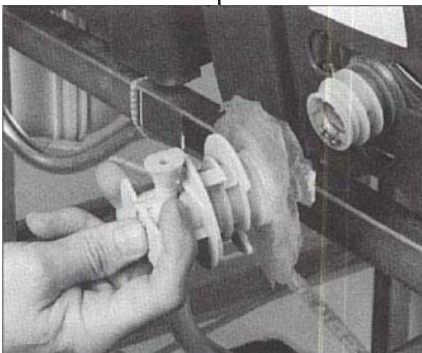
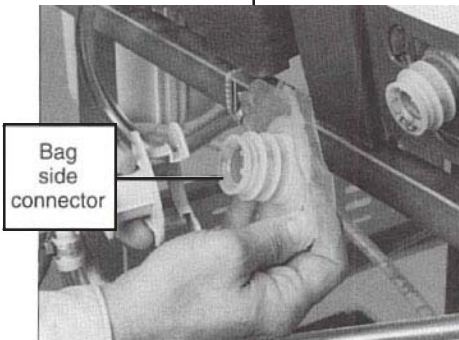
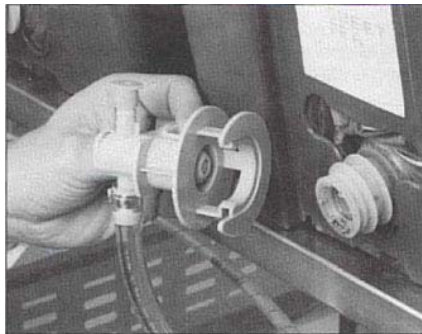

- ② Disconnect the "syrup-line side" of the bag-in-box connector.
3. Rinse connector with warm tap water.
- ④ Connect syrup connector to BIB connector and immerse both into Bucket 1. A "bag-side" connector can be created by cutting the connector from an empty disposable syrup bag.
5. Draw rinse water through system until clean water is dispensed. Most beverage valves allow the syrup side to be manually activated by depressing the syrup pallet.
6. Connect Bucket 2 to system.
7. Draw detergent solution through system until solution is dispensed.
8. Repeat steps 2-7 until all syrup circuits contain detergent solution.
9. Allow detergent solution to remain in the system for 5 minutes.

# USER MAINTENANCE

---

## BAG-IN-BOX SYSTEM

10. Connect Bucket 3 to system.
11. Draw sanitizing solution through system until solution is dispensed.
12. Repeat step 11 until all syrup circuits contain sanitizer solution.
13. Allow sanitizer solution to remain in system for 15 minutes.
14. Remove nozzles and diffusers from beverage valves.
15. Scrub nozzles, diffusers and all removable valve parts (except electrical parts) with a plastic brush or a soft cloth and the detergent solution.
16. Soak nozzles, diffusers and removable valve parts (except electrical parts) in sanitizer for 15 minutes.
17. Replace nozzles, diffusers and valve parts.
18. Connect Bucket 1 to system.
19. Draw rinse water through system until no presence of sanitizer is detected.
20. Attach syrup connectors to BIB's.
21. Draw syrup through system until only syrup is dispensed.
22. Discard first 2 drinks.

# EXPLODED VIEWS, PARTS & DIAGRAMS

## MII-250 EXPLODED VIEW WITH 8 VALVE FLEX MANIFOLD

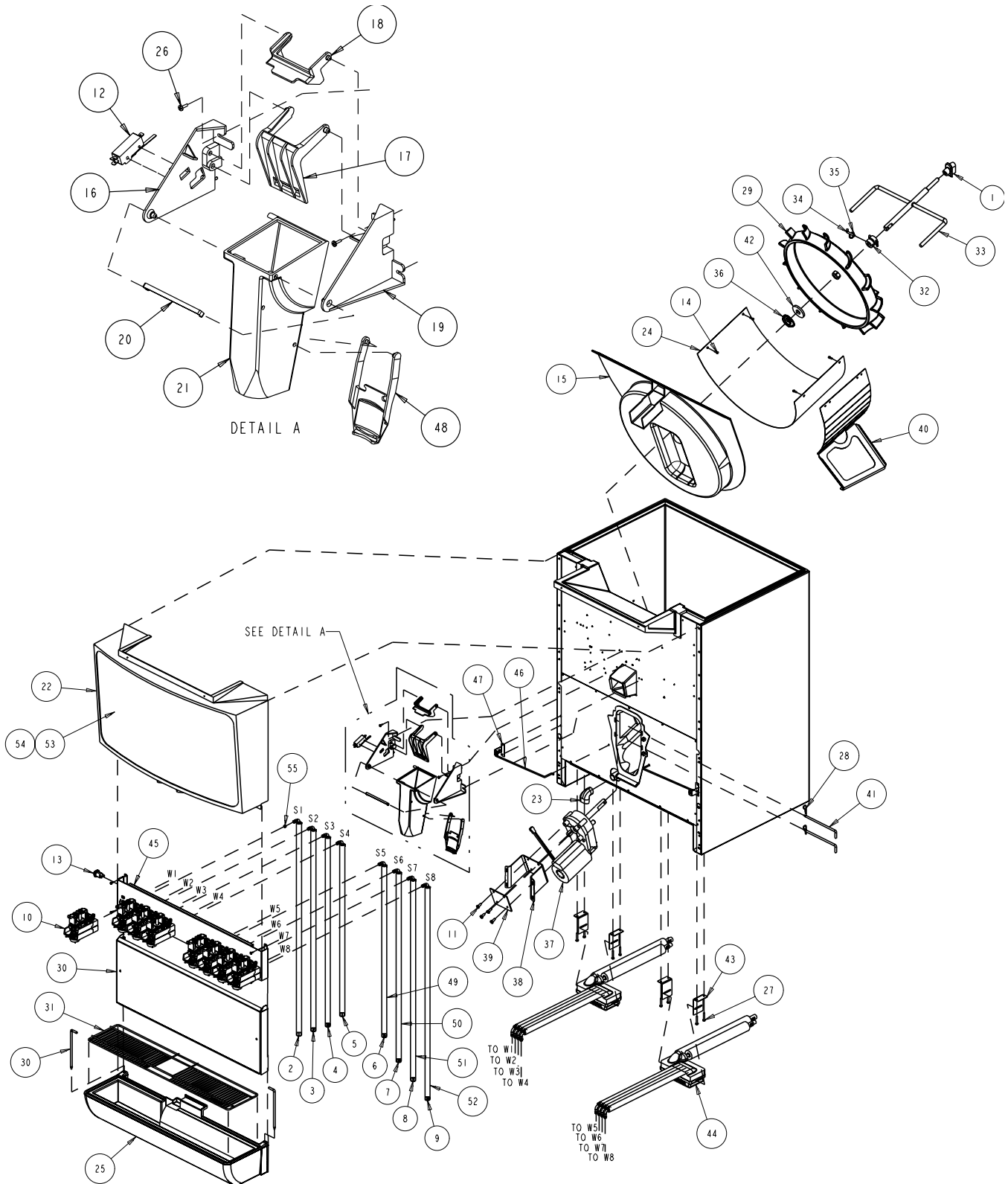

# EXPLODED VIEWS, PARTS & DIAGRAMS

## MII-250 PARTS LIST

No.	Part Number	Description	Qty.
1	0101702	BSHG MUSHROOM INJ MLD	1
2	00200196	LABEL #1 TUBE ID	1
3	00200197	LABEL #2 TUBE ID	1
4	00200198	LABEL #3 TUBE ID	1
5	00200199	LABEL #4 TUBE ID	1
6	00200200	LABEL #5 TUBE ID	1
7	00200201	LABEL #6 TUBE ID	1
8	00200202	LABEL #7 TUBE ID	1
9	00200203	LABEL #8 TUBE ID	1
10	00557500	VLV DOLE FFV 3.00Z/SEC	8
11	0900601	BOLT 1/4-20X5/8" SS HHCS	4
12	1000703	MICROSWITCH	1
13	5000220	KEYSWITCH	1
14	5000711	SCR 8-32 X 1/2" KNURL UNSLOT	4
15	5001052_	PADDLE WH 9.75 AREA	1
16	5002507	MOUNT ROCKING CHUTE DOOR LEFT	1
17	5002508	DOOR ROCKING CHUTE	1
18	5002509	LOCK ROCKING CHUTE DOOR	1
19	5002657	MOUNT ROCKING CHUTE DOOR RIGHT	1
20	5003963	BRACKET ROCKING CHUTE OUTER	1
21	5004850	CHUTE RC NARROW	1
22	5008418_	MERCH RC BLK	1
23	5010337	ELBOW 90 DEGREE RUBBER	1
24	5010962_	LINER BIN	1
25	5011238	DRAINPAN INJ MLD	1
26	5011940	SCREW 8-32 X 1/2	6
27	5011953	SCR 10-24X1-1/4 SELF TAP	8
28	5012374	CLIP HITCH PIN	2
29	5012544	PADDLE WH PLAS DBL D	1
30	5028107	PANEL SPLASH DEEP	1
31	5028201	GRID DRAINPAN	1
32	5028475	COUPLING DBL D	1
33	5028476	AGIT	1
34	5028693	PIN 1/4" X 45 DEG RETAINING	2
35	5028715	RING SS SPLIT	2
36	5029846	BSHG PADDLE WHEEL AREA	1
37	5030517	MOTOR 115V DBL D SHAFT	1
38	5030613	BRKT MOTOR MNT 12GA	1
39	5030654	MNT MOTOR PLATE	1
40	5030704	SUPPORT BIN LINER	1
41	5030743	PIN RETAINING	4
42	5030785	SPACER	1
43	5030983	BRKT FLEX MANIFOLD	4
44	5031038	MANIFOLD 4 VLV FLEX	2
45	5031092	CAP VLV MNT W/SUPPORT	1
46	5031138	ROD SUP	2
47	5031139	CLIP PANEL SPLASH DEEP	2
48	5031147	SANITARY LEVER NARROW ROCKING CHUTE PLASTIC	1
49	5031164	TUBING SYRUP 29"	2
50	5031165	TUBING SYRUP 32"	2
51	5031166	TUBING SYRUP 34"	2
52	5031167	TUBING SYRUP 36"	2
53	5013186	MEDALLION SWEET MCTREATS	1
54	5011648	MEDALLION SS	1
55	5009080	010 O-RING .239 ID X .070W	16

# EXPLODED VIEWS, PARTS & DIAGRAMS

## MII-302 EXPLODED VIEW WITH TWO 6 VALVE FLEX MANIFOLDS

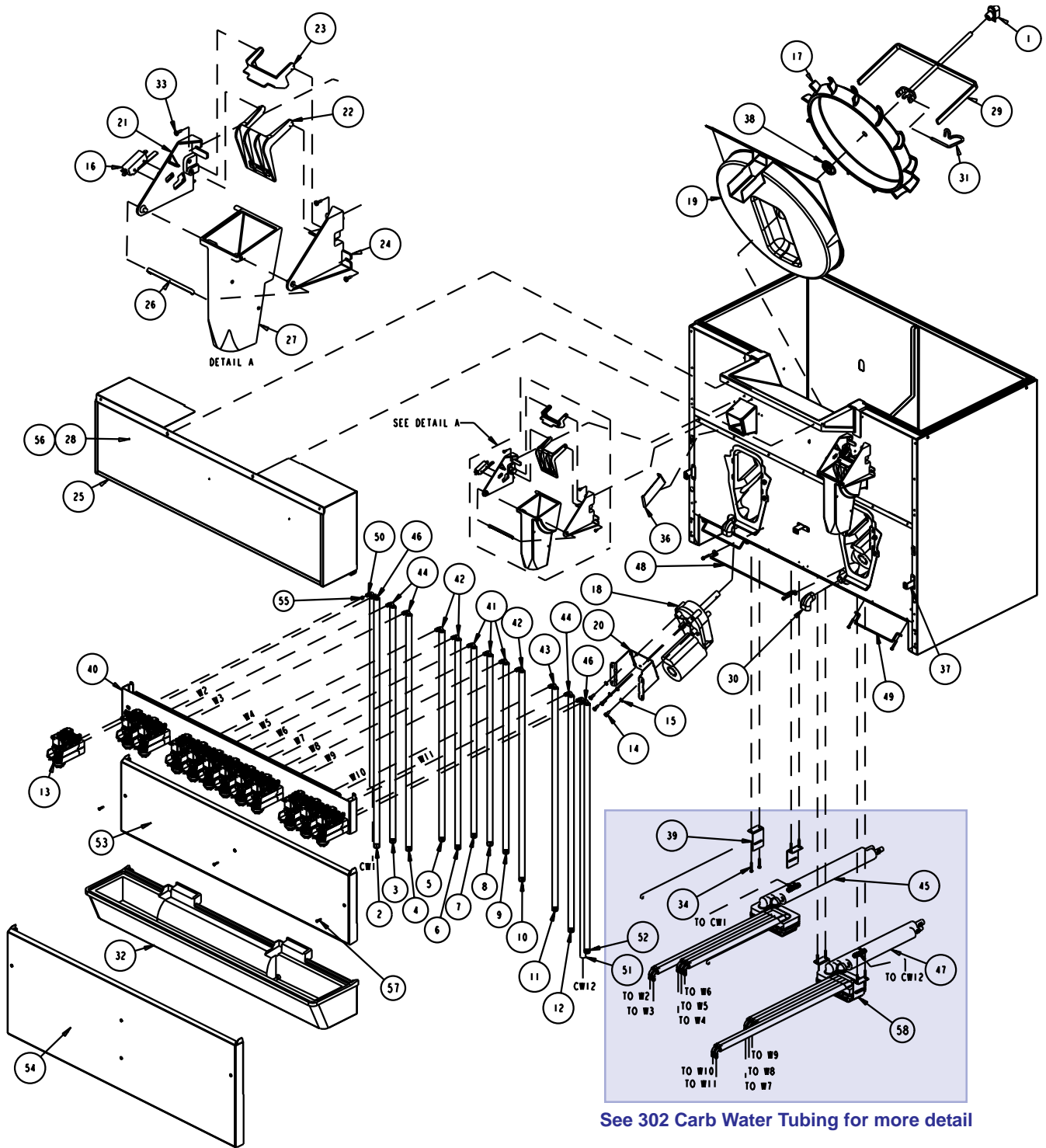

# EXPLODED VIEWS, PARTS & DIAGRAMS

## MII-302 PARTS LIST

No.	Part Number	Description
1	0101702	BSHG MUSHROOM INJ MLD
2	00200196	LABEL #1 TUBE ID
3	00200197	LABEL #2 TUBE ID
4	00200198	LABEL #3 TUBE ID
5	00200199	LABEL #4 TUBE ID
6	00200200	LABEL #5 TUBE ID
7	00200201	LABEL #6 TUBE ID
8	00200202	LABEL #7 TUBE ID
9	00200203	LABEL #8 TUBE ID
10	00200204	LABEL #9 TUBE ID
11	00200205	LABEL #10 TUBE ID
12	00205611	LABEL #11 TUBE ID
13	00557500	VLV DOLE FFV 3.00Z/SEC
14	00900601	BOLT 1/4-20X5/8" SS HHCS
15	00901904	1/4 LOCK WASHER
16	1000703	MICROSWITCH
17	2601415	PADDLEWHEEL "REF. DWG. 7060001"
18	5000868	MOTOR AY-62
19	5001051	PADDLE WH 9.75 AREA
20	5001776	MOUNT MOTOR
21	5002507	MOUNT ROCKING CHUTE DOOR LEFT
22	5002508	DOOR ROCKING CHUTE
23	5002509	LOCK ROCKING CHUTE DOOR
24	5002657	MOUNT ROCKING CHUTE DOOR RIGHT
25	5003709	MERCH SPOTWELD
26	5003963	BRACKET ROCKING CHUTE OUTER
27	5004850	CHUTE RC NARROW
28	5009173	MEDALLION METAL
29	5009529	AGITATOR U-BAR

No.	Part Number	Description
30	5010337	ELBOW 90 DEGREE RUBBER
31	5010452	PIN U-BAR AGITATOR
32	5010639	DRAINPAN W/O GRID BLK
33	5011940	SCREW 8-32 X 1/2
34	5011953	SCR 10-24X1-1/4 SELF TAP
35	5012944	8-32 X 1/2 FLAT HEAD SCREW
36	5013803	Restrictor Ice Flow
37	5028040	CLIP PANEL SPLASH DEEP
38	5029846	BSHG PADDLE WHEEL AREA
39	5030983	BRKT FLEX MANIFOLD
40	5031093	CAP VLV MNT W/SUPPORT
41	5031164	TUBING SYRUP 29"
42	5031165	TUBING SYRUP 32"
43	5031166	TUBING SYRUP 34"
44	5031167	TUBING SYRUP 36"
45	5031473	MANIFOLD 5 VLV FLEX LFT
46	5031483	TUBING SYRUP 38"
47	5031484	MANIFOLD 5 VLV FLEX RT
48	5031561	ROD SUP MIDDLE
49	5031562	ROD SUP LFT AND RT SIDES
50	5031573	TUBE CARB WATER 1
51	5031574	TUBE CARB WATER 12
52	5031625	LABEL #12 TUBE ID
53	020000478	PANEL SPLASH DEEP
54	020000479	PANEL SPLASH DEEP EXTENDED
55	5009080	010 O-RING .239 ID X .070W
56	5007282	MEDALLION DURATRAN COCA COLA
57	5012944	SCR #8 X 3/4 PH FLAT HD
58	5012187	MANIFOLD 5 PORT KIT

# EXPLODED VIEWS, PARTS & DIAGRAMS

## MII-302 CARB WATER TUBING

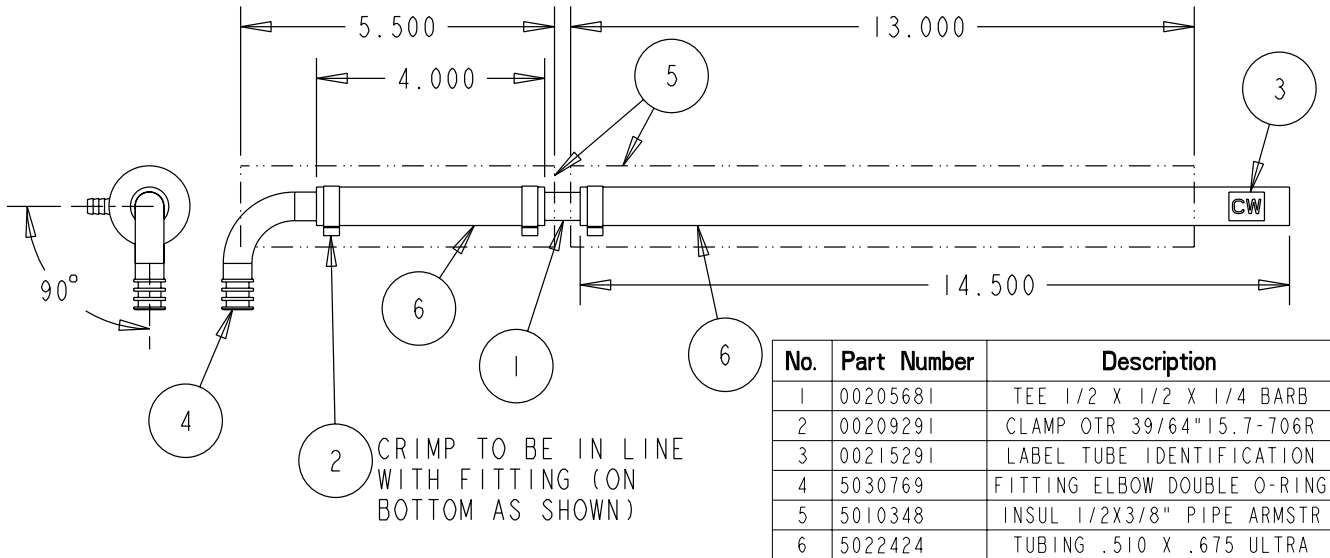
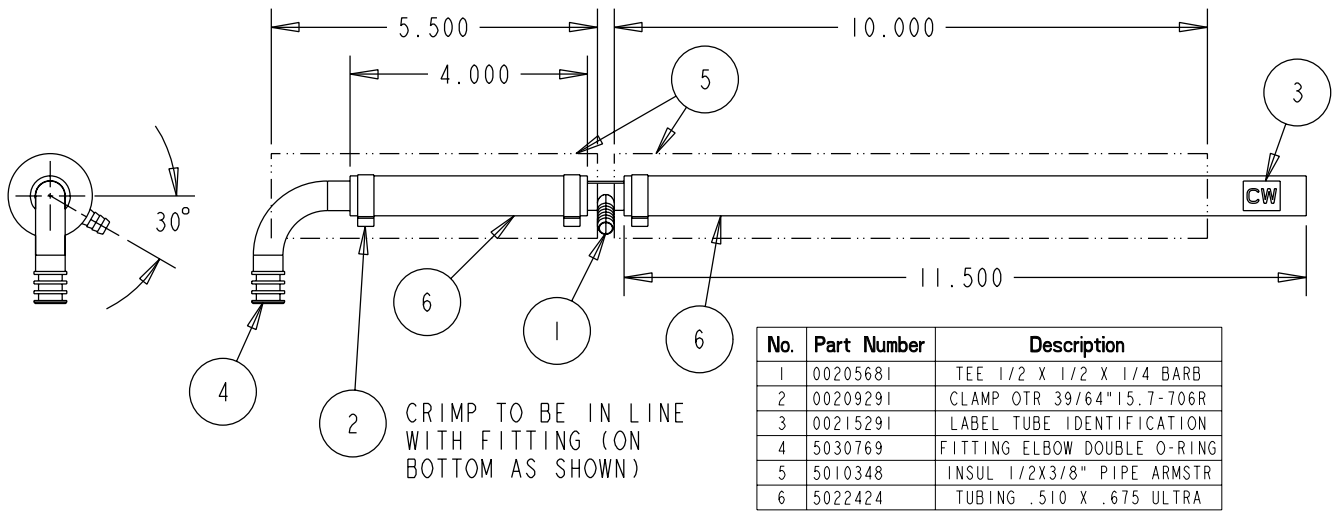

# EXPLODED VIEWS, PARTS & DIAGRAMS

## STRIP LID ASSEMBLY (5030332)

Optional bin adaptor for MII 200/250 for Manitowoc IB Series or Scotsman Eclipse ice makers.

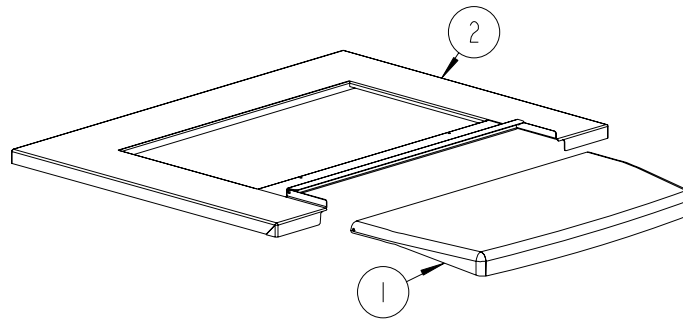

No.	Part Number	Description	Qty.
1	5030309	LID MAN FILL SS	1
2	5030456	LID STRIP SL14 WELD	1

## MII-250 115V WIRING DIAGRAM

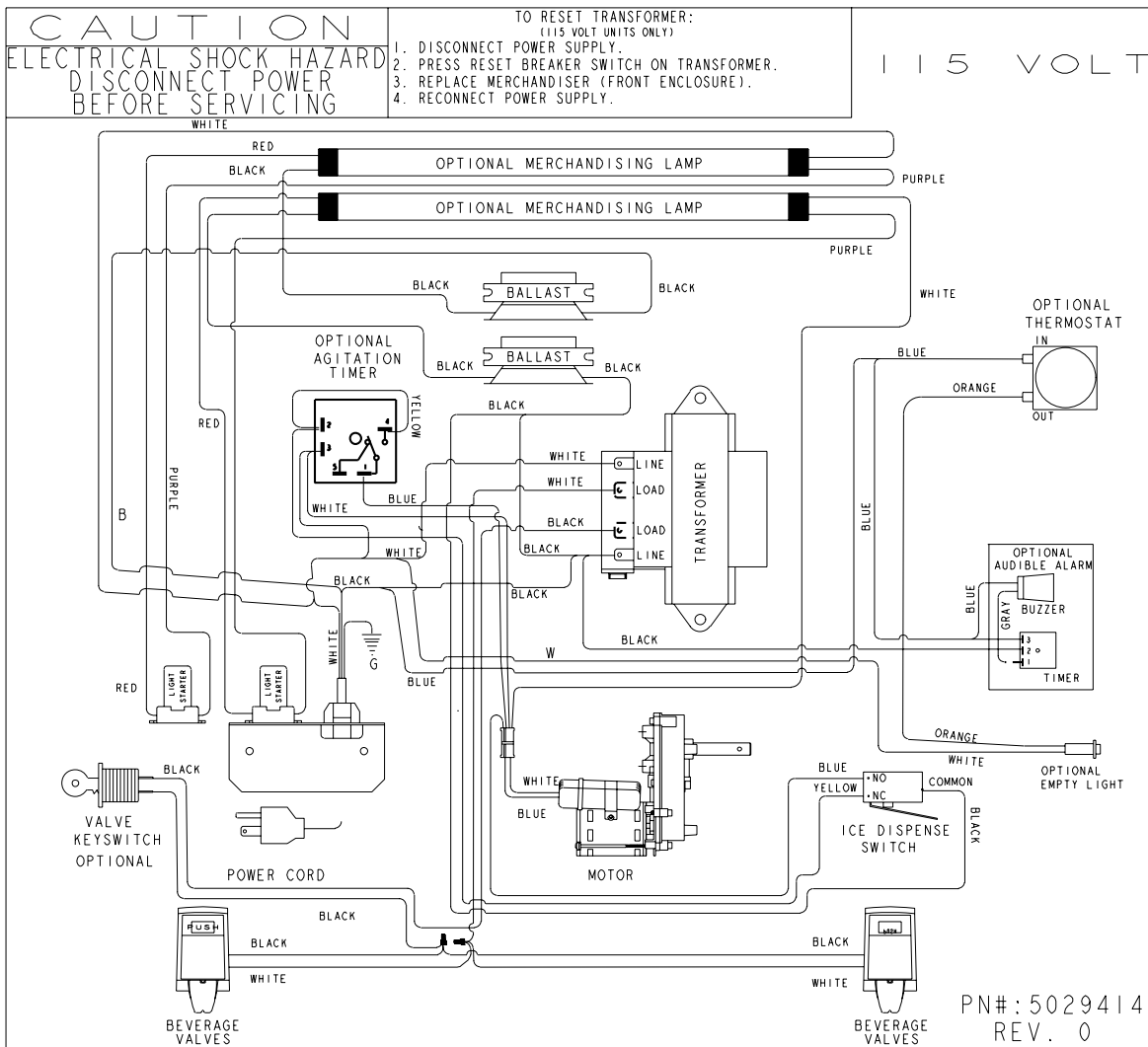

# EXPLODED VIEWS, PARTS & DIAGRAMS

## MII-302 115V WIRING DIAGRAM

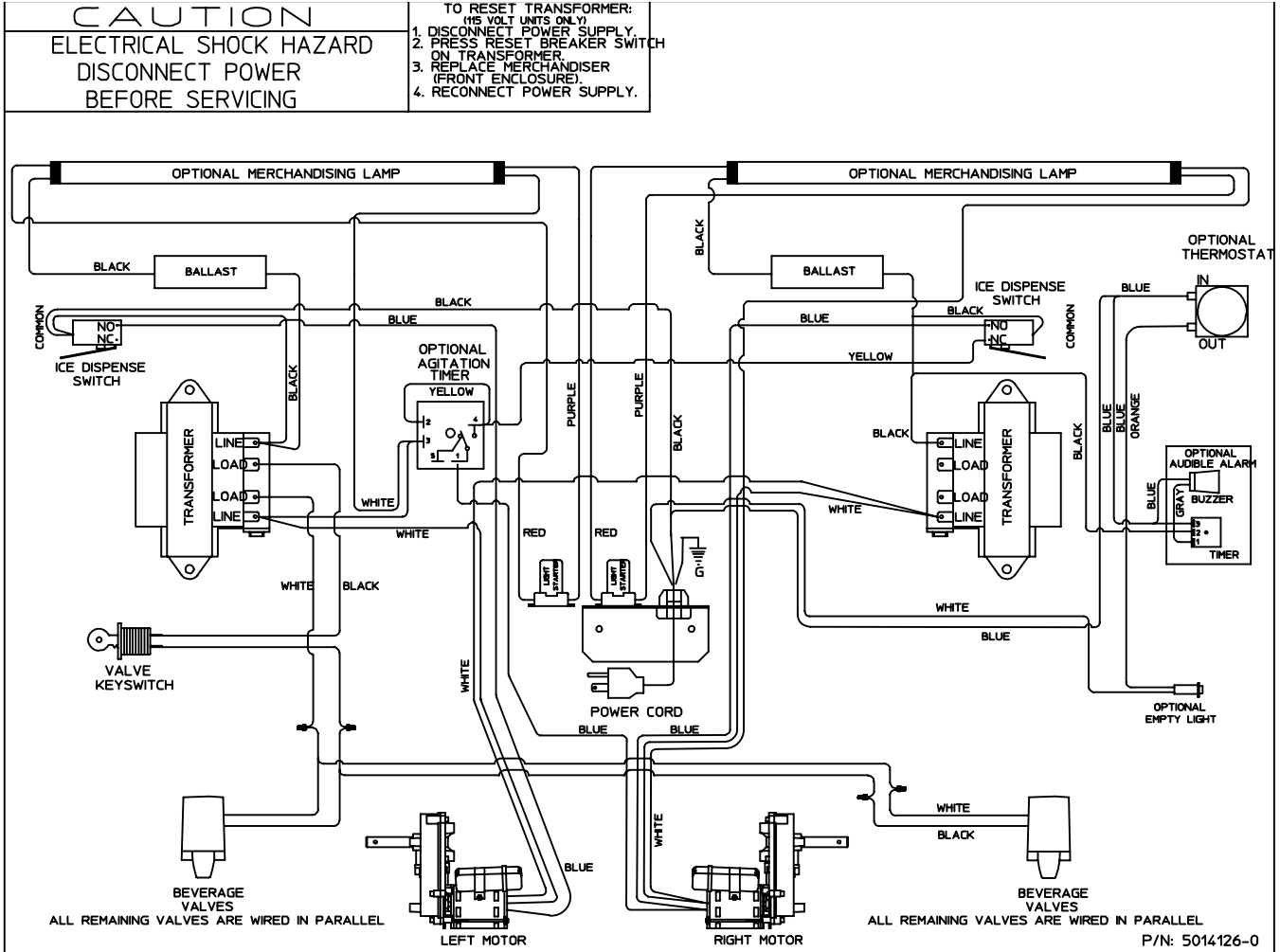

## TROUBLESHOOTING

PROBLEM	POSSIBLE CAUSE	CORRECTIVE ACTION
<b>Dispenser will not dispense ice (and NO SOUNDS are heard when machine is activated).</b>	No power.	Check electrical connection.
	Loose wire in electrical system.	Thoroughly check all wire connections.
	Dispenser overloaded with ice.	Remove ice from dispenser until unit will operate.
	Motor not working..	Check thermally protected motor. Replace motor or capacitor if necessary.
<b>Dispenser will not dispense ice (motor runs but no ice movement is heard in bin).</b>	No ice in bin.	Fill dispenser with ice.
	Door not opening.	Check rocking chute mechanism or electric solenoid operation.
	Paddle wheel pin slipped from the paddle wheel.	Replace paddle wheel pin.
<b>Excessive clustering or bridging of ice.</b>	Loaded ice not broken up. (Warning: Super cooled ice is not covered by the Servend warranty.)	Break ice clusters before manually filling the dispenser. (See ice recommendations)
	Excessive water spilling from the ice maker.	Adjust ice maker to eliminate water spillage.
	Poorly adjusted ice maker.	Adjust ice maker to eliminate large waffle shapes.
	Extremely low usage of the dispenser.	Lower the ice level in the bin.
<b>Ice Dispenses continuously.</b>		
	Misaligned microswitch.	Adjust microswitch.
	Agitation timer set incorrectly.	Test agitation timer.
<b>Thumping noise or irregular sound at a particular area of the dispenser.</b>	Shaved ice clusters in the bin.	Remove clusters, discover why ice is shaving, and then repair.

## TROUBLESHOOTING

PROBLEM	POSSIBLE CAUSE	CORRECTIVE ACTION
<b>Dispensing crushed ice or reduced dispensing speed.</b>	Water spillage from ice machine into dispenser bin.	Adjust ice maker.
	Agitation timer	Test agitation timer.
	Bridge of ice sheet is too thick.	Adjust ice maker.
	Paddle wheel area broken or cracked.	Replce paddle wheel area.
	Ice clusters in bin.	Break up or remove clusters.
	Door not fully open.	Adjust door.
<b>Door will not close.</b>	Ice jammed in chute.	Adjust bridge in ice maker or, when manually filling, break up clusters.
	Door and/or door lock has come out of place.	Replace door and lock into proper position.
<b>Mounting brackets for rocking chute have spread too far apart.</b>		Bend parts into shape.





**DO NOT USE**

***Under  
Preventative  
Maintenance***

**Please post this page in front of dispenser when cleaning system.**





# INDEX

---

## B

Back Room Package ..... 25  
brixing ..... 3

## C

Carbon Dioxide ..... 6  
CAUTION ..... 31  
claims ..... 19  
Cleaning ..... 3  
CO2 ..... 7  
CO2 monitors ..... 7  
cube ice ..... 19

## D

damage ..... 3, 19  
delivery ..... 3, 19  
Diagrams  
34, 35, 36, 37, 38, 39, 40  
Dispensing ..... 19  
dispensing valves ..... 30  
distributor ..... 3  
Drain ..... 8  
ducts ..... 8

## E

Exploded Views  
34, 35, 36, 37, 38, 39, 40  
exterior ..... 30

## F

FOREWORD ..... 3

## H

health department ..... 30

## I

Ice ..... 19  
Ice Storage ..... 19  
INSPECTION ..... 3  
inspection ..... 19  
INSTALLATION  
8, 9, 10, 11, 12, 13, 14, 15, 16, 17, 18  
Installation Date ..... 3  
Instructions ..... 30  
irregularities ..... 3

## L

location ..... 8

## M

MBE ..... 3  
Model Number ..... 3  
modifications ..... 6  
Monthly Cleaning ..... 31

## O

Operation ..... 6

## P

Parts 34, 35, 36, 37, 38, 39, 40  
Power outlet ..... 8

## Q

Qualified Service Personnel ..... 6

## R

regulations ..... 30  
Relocation ..... 6  
return procedures ..... 3

## S

SAFETY ..... 6, 7  
sanitizing ..... 7  
Serial Number ..... 3  
service assistance ..... 3  
Service Personnel ..... 6  
Shipping ..... 6  
Shipping, Storage, Relocation .. 6  
soapy water ..... 31  
solvents ..... 31  
start-up ..... 6  
Storage ..... 6

## T

TABLE OF CONTENTS ..... 5  
TROUBLESHOOTING ..... 41, 42

## U

Unit Inspection ..... 19  
UNPACKING ..... 3

## W

Warning ..... 6  
WARRANTY INFORMATION ... 3  
Water line ..... 8  
water-to-syrup ratio. See brixing



### **Manitowoc Beverage Equipment**

2100 Future Drive • Sellersburg, IN 47172-1868  
Tel: 812.246.7000, 800.367.4233 • Fax: 812.246.9922  
[www.manitowocbeverage.com](http://www.manitowocbeverage.com)

In accordance with our policy of continuous product development and improvement, this information is subject to change at any time without notice.