



Servend.



CF-1522 Beverage Dispensers

Installation, Use & Care Manual

This manual is updated as new information and models are released.
Visit our website for the latest manual. www.manitowocfsg.com

Leader in Ice & Beverage Dispensers

Part Number 020002472 04/09

Manitowoc



Safety Notices

As you work on Manitowoc equipment, be sure to pay close attention to the safety notices in this manual. Disregarding the notices may lead to serious injury and/or damage to the equipment.

Throughout this manual, you will see the following types of safety notices:

Warning

Text in a Warning box alerts you to a potential personal injury situation. Be sure to read the Warning statement before proceeding, and work carefully.

Caution

Text in a Caution box alerts you to a situation in which you could damage the equipment. Be sure to read the Caution statement before proceeding, and work carefully.

Procedural Notices

As you work on Manitowoc equipment, be sure to read the procedural notices in this manual. These notices supply helpful information which may assist you as you work.

Throughout this manual, you will see the following types of procedural notices:

Important

Text in an Important box provides you with information that may help you perform a procedure more efficiently. Disregarding this information will not cause damage or injury, but it may slow you down as you work.

NOTE: Text set off as a Note provides you with simple, but useful, extra information about the procedure you are performing.

Read These Before Proceeding:

Caution

Proper installation, care and maintenance are essential for maximum performance and trouble-free operation of your Manitowoc equipment. Read and understand this manual. It contains valuable care and maintenance information. If you encounter problems not covered by this manual, do not proceed, contact Manitowoc Foodservice Group. We will be happy to provide assistance.

Important

Routine adjustments and maintenance procedures outlined in this manual are not covered by the warranty.

Warning

PERSONAL INJURY POTENTIAL

Do not operate equipment that has been misused, abused, neglected, damaged, or altered/modified from that of original manufactured specifications.

NOTE: SAVE THESE INSTRUCTIONS.

We reserve the right to make product improvements at any time. Specifications and design are subject to change without notice.

Table of Contents (continued)

Section 1

General Information

Read This Manual	1-1
Unit Inspection	1-1
Model Numbers	1-1
Serial Number Location	1-2
Warranty Information	1-2

Section 2

Installation Instructions

General System Overview	2-1
Pre-installation Checklist	2-2
Unit Dimensions	2-4
Location	2-4
Footprints	2-5
CF-1522	2-5
Electrical	2-6
General	2-6
Minimum Circuit Ampacity	2-6
Electrical Requirements	2-6
Voltage	2-6
Minimum Circuit Amperage Chart	2-6
Grounding Instructions	2-6
Unit Installation	2-8
Placing the Unit and Operation Setup	2-9
Purging Air from the Carbonator Tank	2-10
Cold Carb and Ambient System Pressures	2-11
Pre-Mix system Installation	2-11
Plumbing Diagrams	2-11
Pre-mix Pressures	2-12
Conversion for non-carbonated flavor	2-12
Starting Your Beverage System & Dispenser	2-13
Install Labels	2-13
Clean Up	2-13

Table of Contents (continued)

Section 3 Operation

Component Identification	3-1
Sequence of Operation	3-1
Post-Mix Drop-Ins	3-1
Pre-Mix Drop-Ins	3-2
Stands	3-2
Cold Plate Beverage Cooling	3-2
Unit Inspection	3-2
Beverage Valves	3-2
CO2 Supply	3-3
Carbonated Water	3-3
Syrup Delivery System	3-3
Water Supply	3-3
Back Room Package	3-4
Figal System	3-4
Figal Tanks	3-5
Racking	3-5
B-I-B	3-5
Pumps	3-5
Auto Bag Selectors	3-5

Section 4 Maintenance

Cleaning	4-1
Disassemble for Cleaning	4-1
Daily Cleaning	4-1
Monthly Cleaning	4-2
Cleaning Checklist	4-2
Preventive Maintenance	4-2
Sanitizing	4-3
Beverage System Cleaning	4-3
Bag-In-Box System Sanitation	4-3
Figal Beverage System	4-4
Shipping, Storage and Relocation	4-4

Section 5 Before Calling for Service

Checklist	5-1
Drink Troubleshooting	5-1
Pump Troubleshooting	5-2

Section 1

General Information

Read This Manual

Manitowoc Foodservice developed this manual as a reference guide for the owner/operator and installer of this equipment. Please read this manual before installation or operation of the machine. A qualified service technician must perform installation and start-up of this equipment, consult **Section 5** within this manual for service assistance.

If you cannot correct the service problem, call your MBE Service Agent or Distributor. Always have your model and serial number available when you call.

Your Service Agent _____

Service Agent Telephone Number _____

Your Local MBE Distributor _____

Distributor Telephone Number _____

Model Number _____

Serial Number _____

Installation Date _____

Unit Inspection

Thoroughly inspect the unit upon delivery. Immediately report any damage that occurred during transportation to the delivery carrier. Request a written inspection report from a claims inspector to document any necessary claim.

Model Numbers

This manual covers the following models:

Beverage Dispensers
CF-1522



Warning

PERSONAL INJURY POTENTIAL

Do not operate equipment that has been misused, abused, neglected, damaged, or altered/modified from that of original manufactured specifications.

Serial Number Location

This number is required when requesting information from your local distributor. The serial number is listed on the SERIAL NUMBER DECAL affixed to the dispenser.

Warranty Information

Consult your local MBE Distributor for terms and conditions of your warranty. Your warranty specifically excludes all beverage valve brixing, general adjustments, cleaning, accessories and related servicing.

Your warranty card must be returned to MBE to activate the warranty on this equipment. If a warranty card is not returned, the warranty period can begin when the equipment leaves the MBE factory.

No equipment may be returned to MBE without a written Return Materials Authorization (RMA). Equipment returned without an RMA will be refused at MBE's dock and returned to the sender at the sender's expense.

Please contact your local MBE distributor for return procedures.

Section 2

Installation Instructions

General System Overview

These instructions are provided to assist the qualified installer. Contact your Manitowoc Beverage Equipment Service Agent or call Manitowoc Beverage Equipment for information regarding start-up services.

Important

Failure to follow these installation guidelines may affect warranty coverage.

The carbonator in the post-mix system normally has two inlet and one outlet connection. One inlet connects to the CO₂ inlet. The other inlet connects the municipal water supply. The outlet carries the carbonated water to the cold plate inlets at the unit. The outlet of the syrup

supply connects to the appropriate coldplate syrup inlet fitting. The syrup flows through the coldplate to be chilled on its way to the valves. The water flows through the coldplate chilling the plain and carbonated water on its way to the valves. When both fluids leave the beverage valve they are mixed in the nozzle of the valve. Out comes a properly cooled, proper ratio soft drink.

When starting a new beverage system of either type, be sure the electrically operated valves are turned off. Assure all connections are made, turn the water supply on to the dispenser. Open CO₂ tank valve and set all pressures. Place ice on the coldplate and allow the coldplate to cool. After the beverage has achieved a 40°F temperature, the ratio of the product (brix) on a postmix system may then be set.

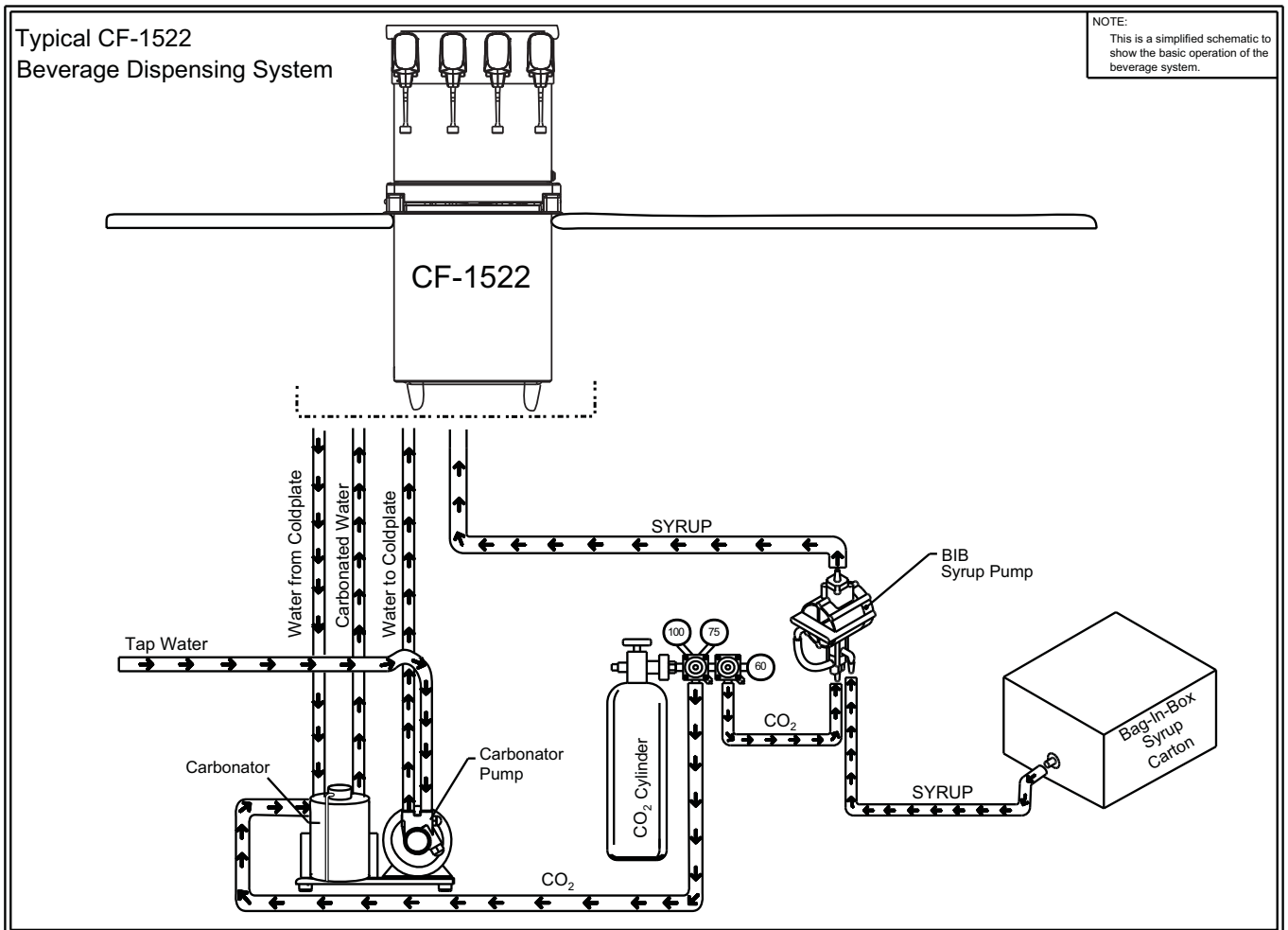

Typical CF-1522 Beverage Dispensing System

Pre-installation Checklist

When installing any system, first make sure the major components are available. Generally the major components necessary for an installation are:

Pre-mix System:

- CO₂ regulator set
- Product connectors for Figal tank
- Gas connectors for Figal tank
- Beverage dispenser
- Beverage tubing
- CO₂ tank
- Figal beverage tanks
- Stepless (Oetiker) clamps
- Chain for CO₂ tank

B-I-B System also:

- B-I-B connectors
- B-I-B regulator set
- B-I-B rack
- B-I-B syrup boxes

Post Mix System:

- CO₂ regulator set
- Beverage dispenser
- Beverage tubing
- CO₂ tank
- Carbonator
- Stepless (Oetiker) clamps
- Chain for CO₂ tank

Figal system also:

- Syrup connectors for Figal tank
- Gas connectors for Figal tank
- Figal syrup tanks

Bulk Syrup System also:

Syrup connectors for Bulk tank

Gas connectors for Bulk tank

Bulk syrup tanks

Double Check:

Do you have enough space to install the dispenser?

Is the countertop level?

Can the countertop support the weight of the dispenser plus the weight of the stored ice?

Also consider the location of the following items before installation:

Water line

Drain

Power outlet

Heating and air conditioning ducts

Unit Inspection

The Servend Drop-In is shipped in a heavy duty corrugated carton with a wooden pallet. Inspect the Drop-In for freight damage. If any damage is noticed, stop immediately and contact your delivering freight company. You must file a freight claim for your equipment. Failure to do so can void any claims. Servend is not responsible for any freight damage.

Unit Dimensions

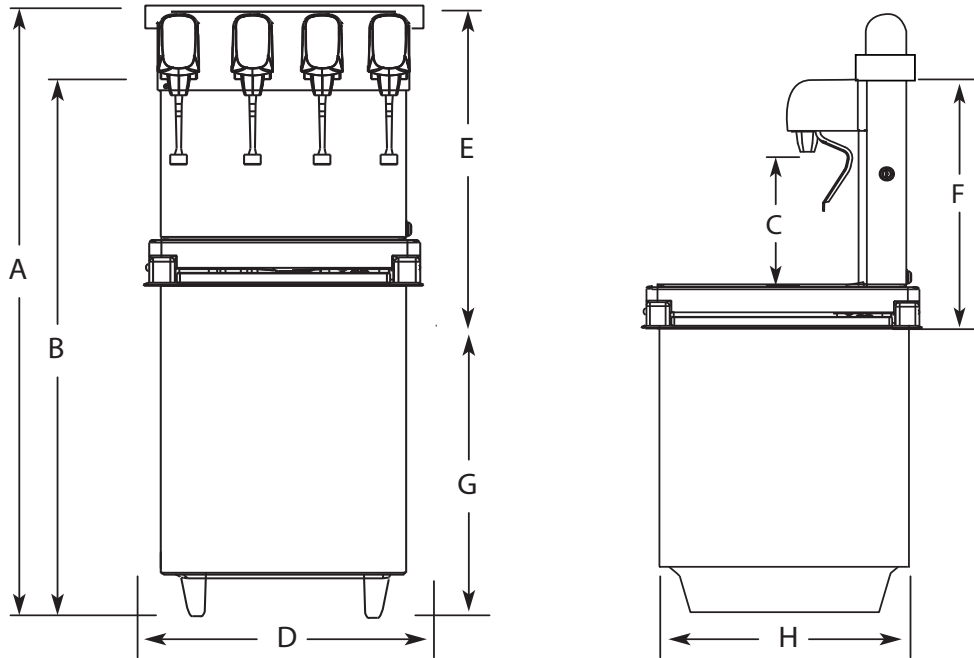

MODEL	A	B	C*	D	E	F	G	H
CF-1522	44.38" (112.8 cm)	38.38" (97.5cm)	9.50" (24.2 cm)	15.00" (38.2 cm)	N/A	16.38" (42.8cm)	22.00" (55.9cm)	22.00" (55.9 cm)

Location

Avoid placing the dispenser near heat sources such as radiators, ovens, refrigeration equipment and direct sunlight.

⚠ Caution

Cutting the countertop may decrease its strength. Counter should be braced to support the dispenser countertop weight plus ice storage capacity and weight of icemaker, if applicable.

Footprints

CF-1522

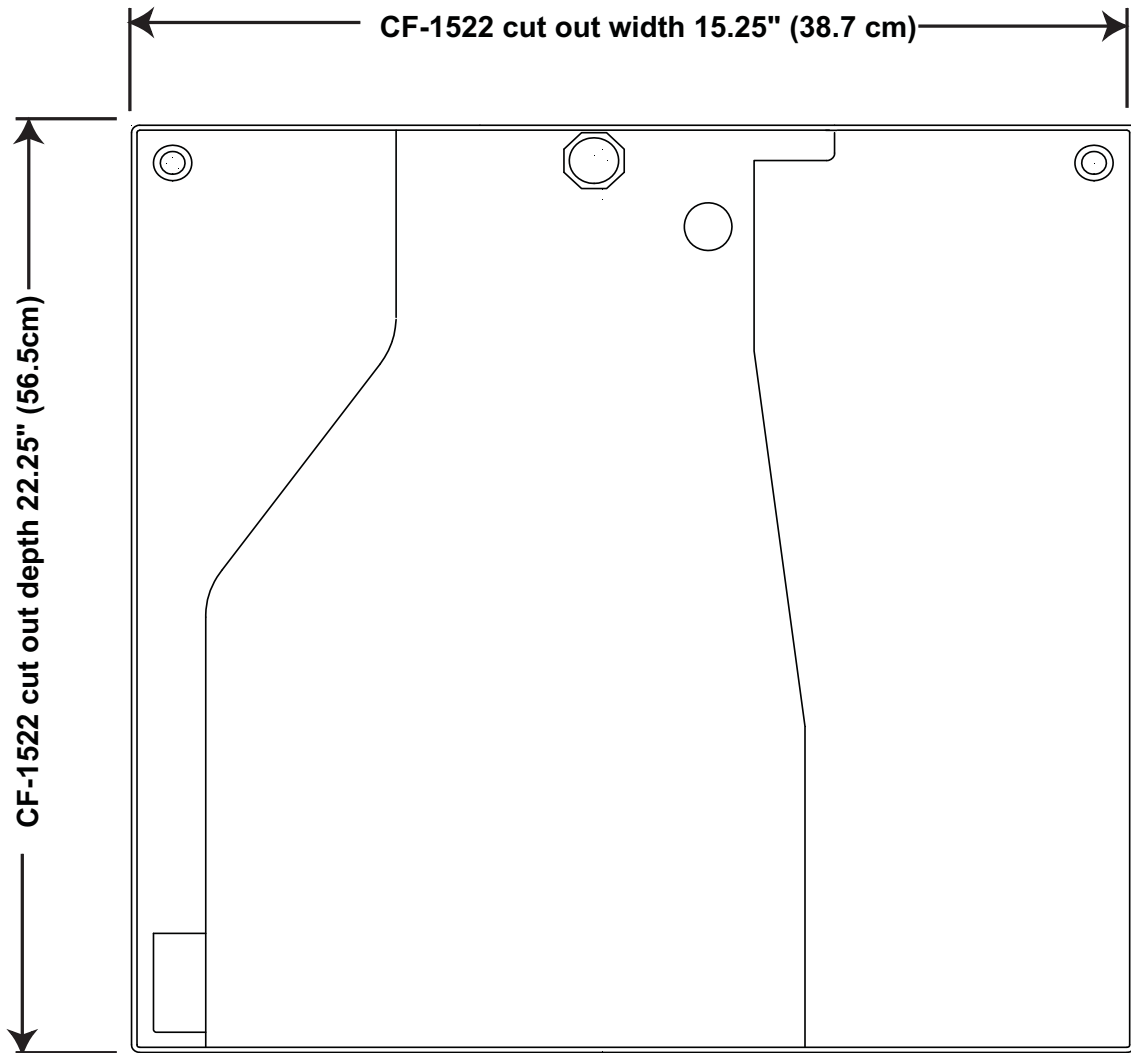

⚠ Caution
Cutting the countertop may decrease its strength. Counter should be braced to support the dispenser countertop weight plus ice storage capacity and weight of icemaker, if applicable.

Electrical

GENERAL

 **Warning**
All wiring must conform to local, state and national codes.

MINIMUM CIRCUIT AMPACITY

The minimum circuit ampacity is used to help select the wire size of the electrical supply. (Minimum circuit ampacity is not the beverage/ice machine’s running amp load.) The wire size (or gauge) is also dependent upon location, materials used, length of run, etc., so it must be determined by a qualified electrician.

ELECTRICAL REQUIREMENTS

Refer to Machine Model/Serial Plate for voltage/ amperage specifications.

VOLTAGE

The standard voltage for CF-1522 dispensers is 120VAC-60Hz 1 Ph. A power cord is provided with 120VAC-60Hz models only. 220/240 Volts - 50 Hz - 1 Ph, 208/230 Volts - 60 Hz - 1 Ph are also available.

MINIMUM CIRCUIT AMPERAGE CHART

Dispenser	Voltage/Cycle	Circuit Amps
CF-1522	120/60	2.4

Optimum Ambient Conditions are between 50°F and 95°F (10°C and 35°C).

Important

Due to continuous improvements, this information is for reference only. Please refer to the dispenser serial number tag to verify electrical data. Serial tag information overrides information listed on this page.

Grounding Instructions

 **Warning**
Risk of electrical shock. Connect to a properly grounded outlet only.

This appliance must be grounded. In the event of malfunction or breakdown, grounding provides a path of least resistance for electric current to reduce the risk of electric shock. This appliance is equipped with a cord having an equipment-grounding conductor and a grounding plug. The plug must be plugged into an appropriate outlet that is properly installed and grounded in accordance with all local codes and ordinances.

 **Warning**

Improper connection of the equipment-grounding conductor can result in a risk of electric shock. The conductor with insulation having an outer surface that is green with or without yellow stripes is the equipment grounding conductor. If repair or replacement of the cord or plug is necessary, do not connect the equipment-grounding conductor to a live terminal. Check with a qualified electrician or serviceman if the grounding instructions are not completely understood, or if in doubt as to whether the appliance is properly grounded. Do not modify the plug provided with the appliance — if it will not fit the outlet, have a proper outlet installed by a qualified electrician.

 **Warning**

When using electric appliances, basic precautions should always be followed, including the following:

- a. Read all the instructions before using the appliance.
- b. To reduce the risk of injury, close supervision is necessary when an appliance is used near children.
- c. Do not contact moving parts.
- d. Only use attachments recommended or sold by the manufacturer.
- e. Do not use outdoors.
- f. For a cord-connected appliance, the following shall be included:
 - Do not unplug by pulling on cord. To unplug, grasp the plug, not the cord.
 - Unplug from outlet when not in use and before servicing or cleaning.
 - Do not operate any appliance with a damaged cord or plug, or after the appliance malfunctions or is dropped or damaged in any manner. Contact the nearest authorized service facility for examination, repair, or electrical or mechanical adjustment.
- g. For a permanently connected appliance — Turn the power switch to the off position when the appliance is not in use and before servicing or cleaning.
- h. For an appliance with a replaceable lamp — Always unplug before replacing the lamp. Replace the bulb with the same type.
- i. For a grounded appliance — Connect to a properly grounded outlet only. See Grounding Instructions.

Unit Installation

Important

The unit must be sealed to the counter to comply with NSF requirements.

To properly install the Servend Drop-In, Use these guidelines:

- Meet all local code requirements.
- Have a receptacle with the proper voltage at the installation site for connection to the Drop-In.
- Completely unpack the Drop-In, removing all padding and shipping retainers.
- Route the beverage tubing from the syrup racks to the location of the Drop-In.
- Make all beverage connections, if necessary, at the syrup racks.
- Mark the counter top with the appropriate cut out opening.
- Check that the cut out location is approved by the owner before any cuts are made in the counter top.
- Compare the marked cut out with the dispenser chest size. Be sure you are going to make the proper hole size.
- Cut the marked opening in the counter top.
- Place one block of wood on the left side of the opening at the edge of the cut out. Place another block of wood on the right side of the opening at the edge of the cut out.

⚠ Caution

Cutting the countertop may decrease its strength. Counter should be braced to support the dispenser countertop weight plus ice storage capacity and weight of icemaker, if applicable.

NOTE: When installing a CF-1522 in a stand it may be necessary to turn the pump head on the pump deck to allow room for water line connections. See figures 1 and 2 on this page for turning the pump head.

1. Loosen the clamp by turning the 5/16" screw.



2. Turn the pump to the position shown and secure in place by retightening the clamp screw.

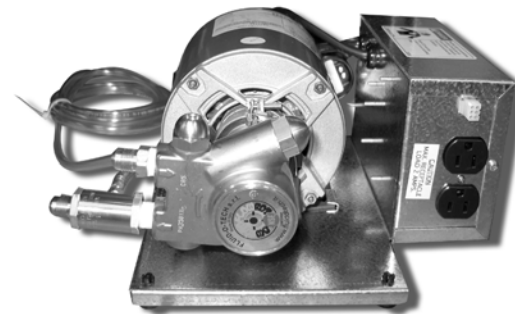

PLACING THE UNIT AND OPERATION SETUP

1. Set the Drop-In in place resting on the two blocks of wood mentioned earlier.

NOTE: Servend has available hooks that fit into the door stop holes. This allows for easier handling of the Drop-In.

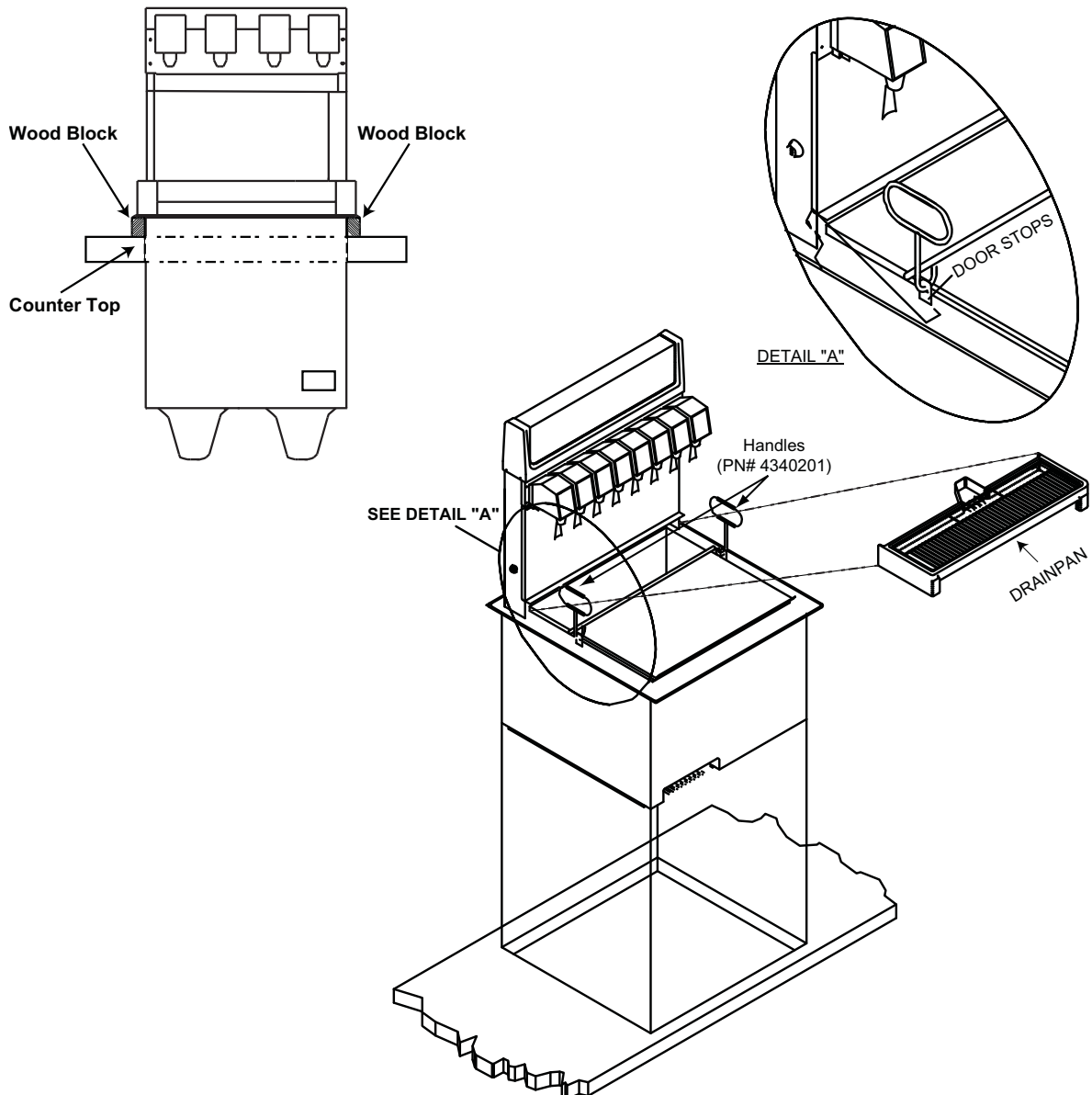

2. Attach the drain lines to the drain connections at the bottom rear of the chest. There is one drain for the drain pan. Another drain fitting is provided for the ice chest. These must be connected separately. (See Purge Tube Routing)
3. Route the purge tube as described in the "Carb Tank Purge Tube Routing" section
4. Connect the carbonator pump deck (power supply) to the valve connection (if equipped) at the Drop-In.

The wires are marked appropriately. Check the electric key switch on the side of the tower. The key should be in the off (vertical) position.

5. The outside edge of the chest flange must be sealed to the counter top. Apply a generous amount of sealant to the underside of the outside edge of the flange.

6. Carefully remove the two blocks of wood from under the flange. The Drop-In will then sit flat on the counter top.
7. Wipe excess sealant from around the outer portion of the flange.
8. Check to be sure the entire flange edge is sealed to the counter top.
9. Apply water and syrup pressure to the beverage system. Check for leaks to the system. Repair any leaks found.
10. Purge air from the carbonator tank. See "Purging Air From The Carbonator Tank" below.
11. Pour about one gallon cold water into the chest. Check for any drain line leaks. Repair any leaks found.
12. Pour about one pint of cold water into the drain pan. Check for any drain line leaks. Repair any leaks found.
13. Install merchandiser to the unit. The cord must be routed down the left side conduit. Connect cord to power supply.
14. Plug power cord (from the carbonator motor) into the unit power cord assembly.
15. Connect the power supply cord from the carbonator deck box to the proper electric supply.
16. Turn the key switch for the valves to the "ON" position.
17. Push each valve operator one at a time. Operate each valve long enough to obtain both syrup and water through the valve.
18. Fill the chest with ice. Allow the coldplate to chill the beverage tubing inside the coldplate.
19. Clean your work area while waiting for the cold plate to cool.
20. After the coldplate has completely chilled, operate one valve for about 15 seconds. Take a temperature reading of the beverage on the next 15 second draw. If the sample drawn is 40°F or lower, go to the next step. If the beverage is higher than 40°F, wait 10 minutes longer for the beverage to attain the proper temperatures. Then repeat this step.
21. When the beverage achieves the proper temperature, set the flow of the water first, then set the flow of the syrup to achieve the ratio (brix) recommended by the syrup supplier.
22. Wipe down the Drop-In and make final inspection of the area. Incoming Water Supply requirements

NOTE: Manitowoc Beverage Equipment recommends that a water shutoff valve and water filter be installed in the incoming water supply line.

The incoming water source to the equipment shall be installed with adequate backflow protection to comply with applicable National, State, and local codes.

Water pressure should be a minimum of 45 psi or you will starve the pump of water and damage it. The maximum water pressure should be 55 psi or you will affect the quality of the carbonation.

The carbonator pump should be located within 6 feet of a 1/2 inch water source. A minimum 3/8 inch ID water line must be used. Before connection the water source should be flushed of approximately 5 gallons of water to purge the system of any sediments, especially in areas of new construction.

PURGING AIR FROM THE CARBONATOR TANK

1. Plumb unit as described in steps 1 - 8. Do not energize the unit. Do not turn on the CO₂ to the unit.
2. Remove the splash panel and open the vent on the carbonator pressure relief valve.
3. Turn on the water to the unit and fill the carbonator with water. Close the vent on the carbonator pressure relief valve when water begins to escape.
4. Follow the instructions in the manual for energizing the unit.
5. Operate any valve to remove all the air from the water lines.

Follow instructions in the manual for remaining unit set up.

COLD CARB AND AMBIENT SYSTEM PRESSURES

1. Incoming tap water should be at a minimum static pressure of 40 psi (2.758 bars) and a maximum of 55 psi (3.792 bars) with carbonator pump operating (measured at inlet to pump).
2. BIB pressure gauge set for 60 psi (4.137 bars) or according to your line run.
3. Carbonator Pressure gauge (Use Preset Regulator):
 - Cold Carbonation set for 75 psi (5.171 bars).
 - Ambient systems should be set at 90 psi (6.205 bars) to 105 psi (7.239 bars).

NOTE: If incoming dynamic water pressure is under 40 psi (2.758 bars), a water booster is recommended. If incoming static water pressure is over 55 psi (3.792 bars), a water regulating valve is required.

PRE-MIX SYSTEM INSTALLATION

These installation steps are general. Each system and installation is unique. You may have to modify these instructions to your particular installation.

1. Lay out the system. Proper planning will eliminate obstacles later in the installation.
2. Recheck the location to assure yourself the proper electric, and drain lines are available.
3. Check to be sure you can route the beverage tubing to the location.
4. If necessary, cut any holes necessary for utilities and beverage tubing, or ice chest.
5. Place the beverage dispenser in the selected location.
6. Place the CO₂ supply tank and the beverage Figal tanks in the proper location.
7. Mark all beverage tube ends (both ends) with the beverage name it is to carry.
8. Route the appropriate number and size beverage tubes to the dispenser location.
9. Reading the dispenser plumbing diagram connect the appropriate beverage tube to the appropriate plumbing inlet.
10. Connect the beverage tubing to the appropriate Figal tanks liquid outlet.
11. Connect the CO₂ lines from the tank to each Figal tank gas inlet.
12. Open the CO₂ tank. Adjust the pressure regulator at the CO₂ tank to 60 psi (4.137 bars) (diet drinks 40 psi (2.758 bars)).

13. Operate each valve at the dispenser until beverage flows out in a steady stream. Do not be concerned that the product foams excessively at this time.
14. Fill the ice chest with ice to cool the cold plate or activate the cooling mechanism of the dispenser. Allow the product to cool sufficiently.
15. Explain how to change a Figal tank and CO₂ tank to the owner/operator.

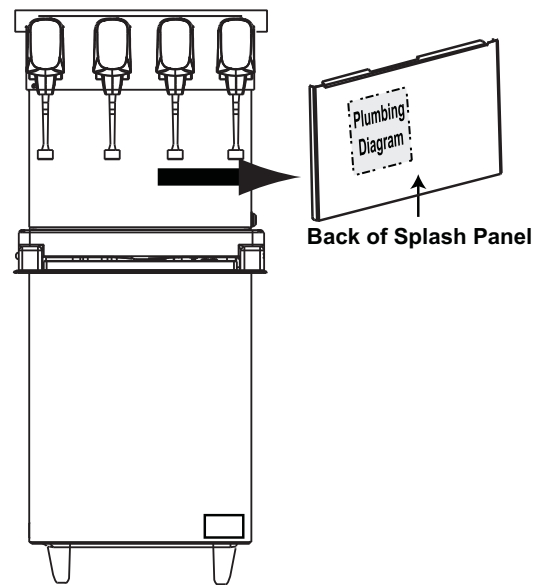
PLUMBING DIAGRAMS**Plumbing Diagram And Flex Manifold Locations**

Install the beverage tubing to the appropriate fittings. Refer to the cold plate drawing on the back of the splash panel for your individual set up. See the example below of how your Drop-In may be hooked up.

NOTE: A check valve must be installed in the water supply line 3 feet from the noncarbonated water connection "PW". Contact factory if not installed.

CF-1522 4 Valve Plumbing

Install the beverage tubing to the appropriate fittings. Refer to the cold plate drawing on the front of the chest for your individual set up. (See the example below of how your Drop-In may be hooked up.)

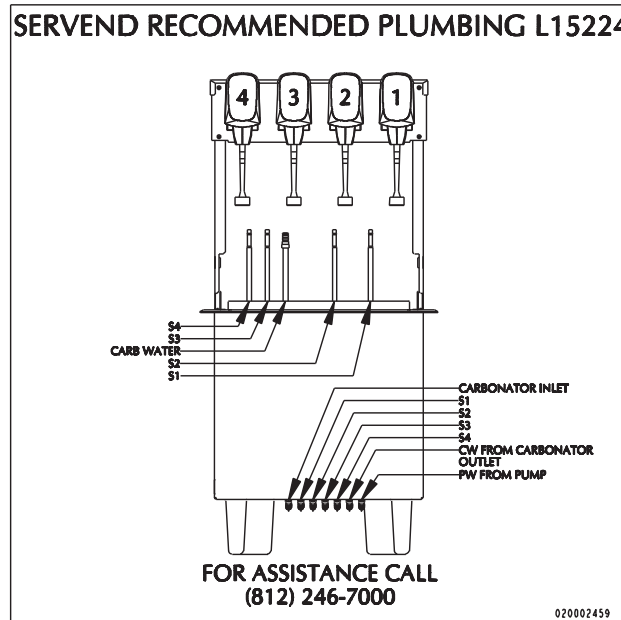

PRE-MIX PRESSURES

Normal pre-mix pressure regulators should be set at 60 PSI. Diet pre-mix pressure regulators should be set at 40 PSI. If you are experiencing high foaming, decreasing the pressures may correct the problem. Spitting and popping usually requires slightly increasing the pressures. Pre-mix beverage valve pressures vary by type and manufacturer. Please consult the manufacturer of the valves you are using for specific instructions regarding operation of the valve.

CONVERSION FOR NON-CARBONATED FLAVOR

1. De-pressurize system.
2. Remove drain grid, splash panel and drainpan to access insulated lines.
3. Cut carb water line (in tower) to valve to be converted and cap.
4. Disconnect syrup line to valve being converted.
5. Plumb syrup circuit in coldplate to water side of valve (flush syrup line first).
6. Plumb dedicated plain water line from water source to coldplate inlet (syrup circuit converted for chilling water).
7. Run ambient syrup line into drop-in tower to syrup side of valve.
8. Replace drainpan, splash panel and drain grid.
9. Pressurize system and verify system operation.

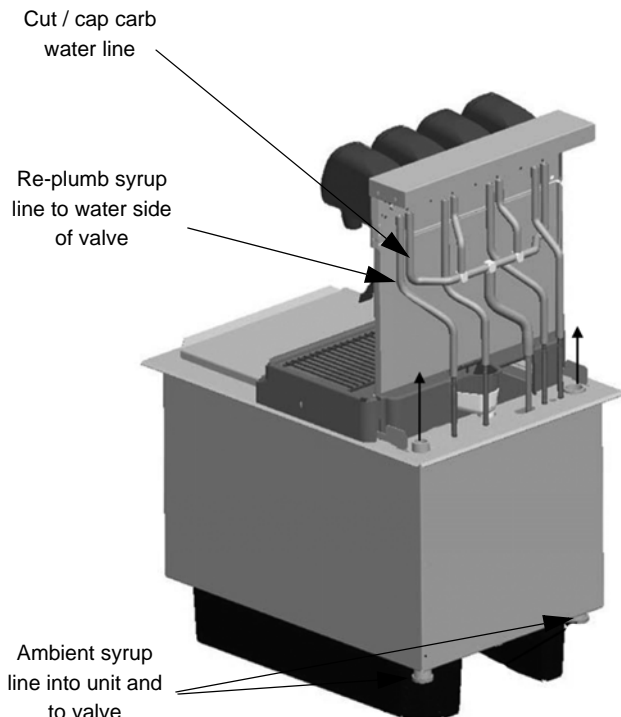

NOTE: Tapping into existing water line too close to the pump deck can result in starving the valve when the carbonator cycles. If a dedicated water line is not possible, tee into the existing water line as close to the source as possible.

STARTING YOUR BEVERAGE SYSTEM & DISPENSER

Upon completion of the beverage dispenser and / or system installation, all tubing, dispenser, and system components must be cleaned and sanitized prior to use.

NOTE: At installation equipment, dispensers, and tubing get moved through many environments, dirt, dust, chases, insulation, drywall, etc. It is an important procedure and best practice to address cleaning to deliver the best quality drink to your customer.

Clean and sanitize the water and syrup circuits according to instructions provided in this manual. Clean and sanitize the dispenser components according to instructions provided in this manual. Consult and use local health codes if a discrepancy occurs between this manual and your local health codes.

Bag-in-Box (BIB) Start-up

All lines should be properly flushed and sanitized before starting the unit. See Sanitizing Instructions

1. Connect each BIB connector to the appropriate BIB.
2. Gradually adjust the secondary regulator to 70 psi. Never run a BIB pump without the BIB installed as the pump could be damaged. Set final secondary regulator pressure 70 -75 psi depending on the line size and the distance of the run.
3. Operate each dispensing valve until the syrup flows smoothly from the valve.

Adjust Syrup to Water Ratio (Brix) of Dispensed Product

1. Adjust water flow rate on each dispensing valve to 2.5 ounces per second.
2. Adjust dispensing valves for water-to-syrup ratio (brix) as recommended by the syrup distributor.

INSTALL LABELS

Install flavor labels (some labels are provided) on the dispensing valve covers.

CLEAN UP

Clean up all work areas. Dispose of all packing material, excess tubing and trash properly.

THIS PAGE INTENTIONALLY LEFT BLANK

Section 3 Operation

Component Identification

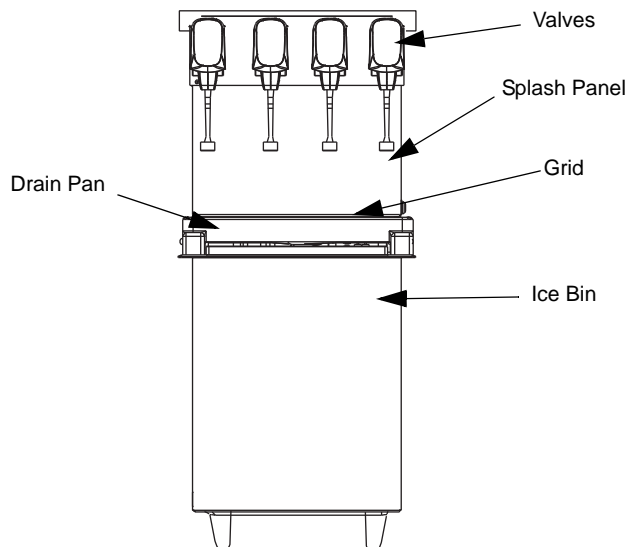

NOTE: This equipment is only intended to dispense beverages and is not designed to be operated outdoors in temperatures below 50° or above 105°.

Sequence of Operation

This section gives the a description of the units, theory of operation, and service data for the Post Mix Dispensers

Important

TO THE USER OF THIS SERVICE MANUAL, THIS MANUAL IS A GUIDE FOR INSTALLING THIS EQUIPMENT. REFER TO THE TABLE OF CONTENTS FOR PAGE LOCATION FOR DETAILED INFORMATION PERTAINING TO QUESTIONS THAT ARISE DURING INSTALLATION AND START-UP OF THIS EQUIPMENT.

POST-MIX DROP-INS

The design of the Servend Drop-In is such that it provides high accessibility to the ice stored in the chest, while allowing maximum convenience of beverage dispensing. The function of a Drop-In is to allow easy and fast access to ice for filling beverage cups, chilling and dispensing carbonated and noncarbonated beverages. The major components of the Cold Carbonated Servend Drop-In dispensers are the ice chest with the sealed-in coldplate, internal carbonator, the beverage valves, valve tower, carbonator pump deck (power supply) and merchandiser (optional). The major components of the Ambient Servend Drop-In dispensers are the ice chest with sealed in cold plate, the beverage valves, valve tower and the merchandiser (optional). An

ambient carbonator will be needed to supply carbonated water to the Ambient Drop-In.

The bottom of the ice chest is the coldplate. The coldplate is a block of aluminum, with serpentine stainless steel tubes molded inside. The stainless steel tubes inside the coldplate carry water to the internal carbonator back through the stainless steel tubes, noncarbonated water (plain water), and beverage syrup to the beverage valves. The water and syrup are chilled to the proper service temperature while flowing through the stainless steel tubes in the cold plate.

The beverage valve is designed to precisely meter the flow of both water and syrup to obtain the proper mixing ratio. These two components of the beverage are mixed as they leave the valve. The valve tower holds the valves above the ice chest and provides a conduit for the beverage tubing and electric wires to pass between the chest and the valves.

The merchandiser assembly consists of the sign, light bulb, and merchandiser frame. The tri-view merchandiser allows viewing the medallion from the front, back, or top.

PRE-MIX DROP-INS

Pre-mix fountain dispensing consists of a container of beverage ready for dispensing, beverage delivery system, carbon dioxide (CO₂) propellant, beverage cooling system, and dispenser. We shall discuss each component of this type of system within the context of this manual.

The major advantage of a pre-mix system over most other types is its flexibility. This flexibility is the ability to go anywhere. Many pre-mix systems will operate without electric power or separate water supply. Most drop-ins are manufactured for post-mix. Unless otherwise stated, operation and installation instructions are for post-mix.

STANDS

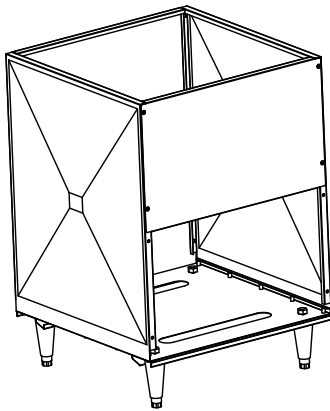

Stands are designed to accommodate drop-in ice bins and to provide an enclosure for carbonators. See instructions provided with those items for proper installation and connections.

COLD PLATE BEVERAGE COOLING

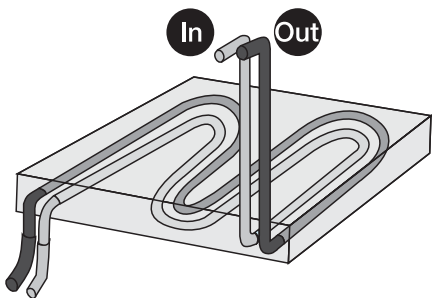

A cold plate is a block of aluminum with serpentine stainless steel tubes molded inside the aluminum block. The cold plate is approximately the same length and width as the bottom of the dispenser bin. Ice sits on top of the cold plate and cools the cold plate. The stainless steel tubes inside the cold plate carry carbonated water (soda water), noncarbonated water (plain water) and syrup to the beverage valves. While flowing through the stainless steel tubes in the cold plate, water and syrup are chilled to serving temperature.

UNIT INSPECTION

This section covers unpacking, inspecting, selecting location, installing the unit, and preparing for operation. Thoroughly inspect the unit upon delivery. Immediately report any damage that occurred during transportation to the delivery carrier. Request a written inspection report from a claims inspector to document any necessary claim.

1. After the unit has been unpacked, remove the keys. The key will be needed to perform brixing of valves. Hold onto the keys until such time to forward them to the respective owner/operator. Remove tape (which secures grid in place in drain pan) from grid and other packing material.
2. Make sure all items are present and in good condition. Loose shipped items in the carton include the drain kit parts and the instructions.
3. Inspect unit for any external damages.

If you have an internal carbonated unit the unit is pre-plumbed at the factory. The inlets for CO₂ and water are located behind the splash panel. There are two inlets for water and one inlet for CO₂. If you have questions refer to the plumbing diagram on your equipment.

BEVERAGE VALVES

Post-mix beverage valves are designed to precisely meter the flow of both water and syrup to obtain the proper mixing ratio. The syrup and soda water components of the post-mix beverage are mixed as they leave the beverage valve.

CO₂ SUPPLY

Note: CO₂ inlet for the internal carbonator is located with the cold plate inlet lines.

(See plumbing diagram for exact plumbing location)

- CO₂ pressure to the BIB pump is 60 to 75 psi.
- CF-1522 CO₂ pressure to the internal carbonator is 75 psi.
- For ambient carbonated systems the CO₂ pressure to the carbonator should be set at 100 PSI
- "Optional" A low CO₂ alarm is available on all internally Carbonated DI series units. A RED low CO₂ light mounted to the tower will illuminate when the CO₂ supply for the carbonator tank starts running low.

A CO₂ cylinder delivers carbon dioxide (CO₂) gas through an adjustable CO₂ regulator to the syrup BIB pump and also to an internal carbonator. Plain water also enters the internal carbonator tank, and is carbonated by the regulated CO₂ gas pressure. When a dispensing valve is opened, CO₂ pressure exerted within the syrup BIB pump propels syrup from the BIB, through the beverage coils, and into the dispensing valve. Carbonated water is forced from the carbonator tank by CO₂ pressure which pushes cold carbonated water into the dispensing valve resulting in a carbonated drink being dispensed. A non-carbonated drink is dispensed in the same manner as a carbonated drink with the exception that plain water is substituted for carbonated.

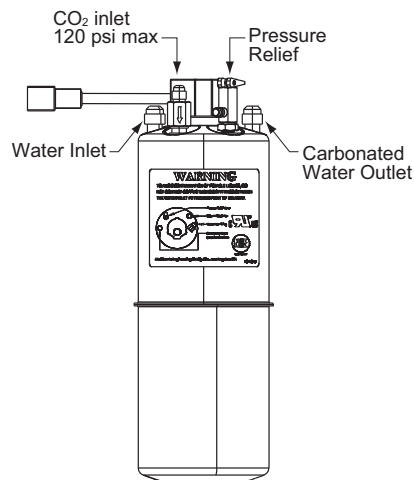

The carbonator is replenished when the carbonated water level inside the tank drops, which in turn automatically starts the carbonator water pump. When the water level inside the tank has been replenished, carbonator water pump will stop.

CARBONATED WATER

Carbon Dioxide (CO₂) leaves the storage tank and arrives at the carbonator tank through the gas inlet. Water supply enters the carbonator pump inlet at regular street water line pressure (minimum 20 PSI, maximum 80 PSI, dynamic or flowing pressure). The water pump increases the pressure of the water, which allows the water to flow into the carbonator tank. The CO₂ and the water mix together in the carbonator to produce the carbonated water that is then sent to the soda dispenser.

The agitation of the water and CO₂ together in the tank under high pressure creates the soda water. The quality of carbonation (percent of CO₂ mixed in the water) increases as the water temperature decreases and exposure time increases.

The water level in the carbonator tank is controlled by a water level control in the tank. This control turns the pump motor off and on to maintain a preset level of liquid in the tank. The water level control may be electronic probes or a mechanical float.

SYRUP DELIVERY SYSTEM

Your syrup location can vary depending on the volume of beverages served and ease of accessibility. Your beverage system may set in a back storage room or under the counter of the dispenser. Configurations are almost limitless. Check the temperatures expected for the storage location. Adverse temperatures can affect the storage and quality of beverage products. It is recommended the temperature of storage location should not fall below 40°F (4°C) or rise above 90°F (32°C).

WATER SUPPLY

For internal carbonated systems:

Incoming water supply minimum of 40 and maximum of 55 psi. If incoming (static) water supply is over 55 psi you have to install a water regulator. If incoming (dynamic) water pressure is under 40 psi a water booster is required.

NOTE: The incoming water supply for the carbonator, which is the pre-chill inlet on the plumbing diagram, must first be ran through the carbonator pump which is located on the carbonator pump deck (power supply).

BACK ROOM PACKAGE

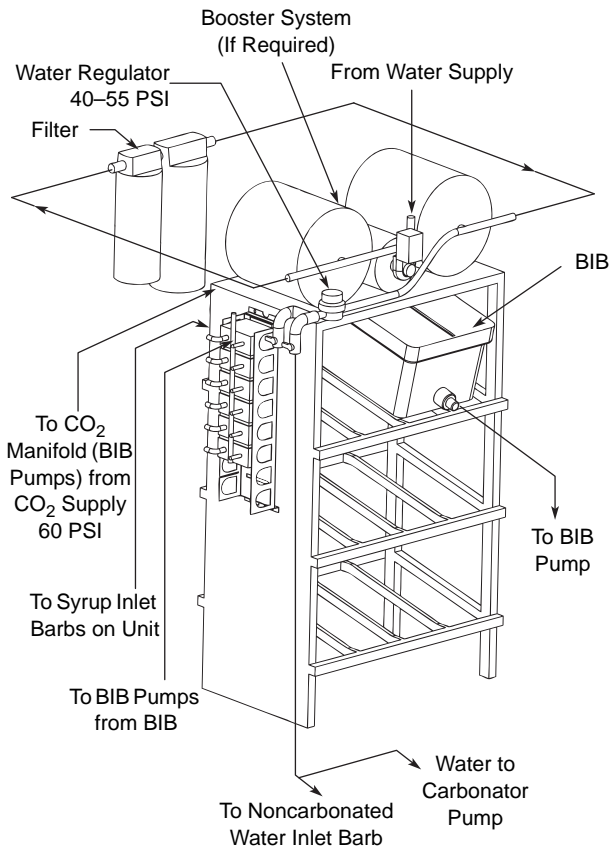

1. **Incoming tap water** - should be at a minimum dynamic pressure of 40 psi and maximum static pressure of 55 psi.
2. **Carbonator Water pump motor** - Powers the water pump. The water pump motor is part of the carbonator pump deck.
3. **Carbonator Water pump** - Pumps tap water into the carbonator tank. The water pump is part of the carbonator. The incoming water for the carbonator must be first run through the pump before connecting to the proper cold plate inlet.
4. **Internal/External Carbonator tank** - Combines CO₂ gas and tap water to form carbonated water. The “carbonator” is the carbonator tank, water pump and water pump motor.
5. **CO₂ cylinder** - Holds highly pressurized carbon dioxide (CO₂). The CO₂ cylinder is a steel or aluminum cylinder tank. CO₂ gas flows through the primary pressure regulator.
6. **BIB pressure gauge** - Set for a minimum of 60 psi. Indicates CO₂ pressure going to B-I-B pumps.

7. **Primary pressure regulator** - Lowers the CO₂ gas pressure, to 100 psi, so the CO₂ gas will be at the proper pressure to enter the carbonator regulator.
8. **Lowered outgoing pressure** - Set for 75 psi. Gauge indicates lowered outgoing pressure from the CO₂ cylinder after being routed through the primary pressure regulator at 100 psi.
9. **Secondary pressure regulator** - Lowers the CO₂ gas pressure before the CO₂ gas flows to the syrup pump. CO₂ pressure activates the syrup pump.
10. **Syrup pump** - Draws syrup out of the bag-in-box syrup package. Syrup flows through the syrup lines to the dispenser for chilling, then dispensing. There is a syrup pump for each bag-in-box syrup system.
11. **Bag-In-Box syrup cartons** - Box which contains a plastic bag, filled with syrup.

FIGAL SYSTEM

Figal refers to the stainless steel tanks of pre-mix beverage or post-mix syrup. The term “Figal” is an abbreviated word. Originally Figal was short for “five gallons”. Today, the term usually refers to any stainless steel tank system used in soft drink beverage supply. The CO₂ to push the beverage from the Figal tank is sourced from a small CO₂ tank.

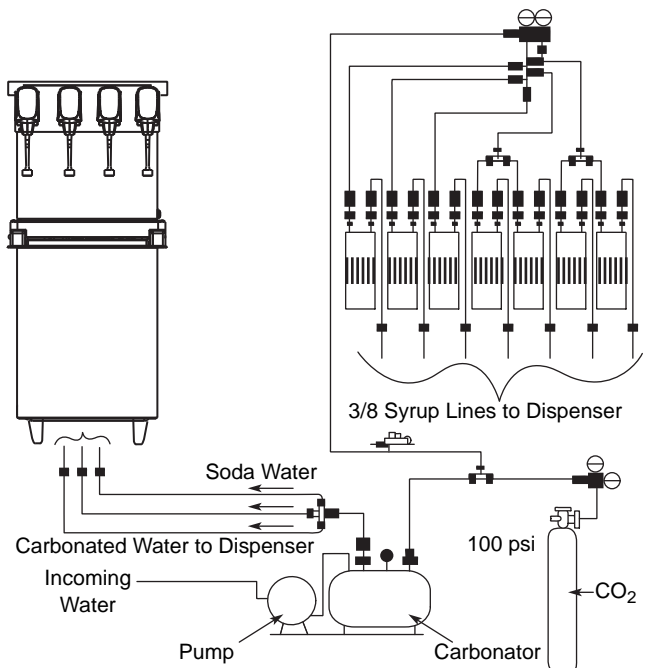

FIGAL TANKS

The stainless steel Figal beverage tanks are easy to store and connect. There are several items to remember when using the Figal tanks:

- Use a gas connector for the inlet fitting of the tank.
- Use a syrup connector for the outlet fitting of the tank.
- If more than one Figal tank is connected in series, when changing tanks, remove the tank closest to the original gas inlet while adding the new tank to the connector closest to the syrup outlet.

Most Figal tanks have a self-closing valve on the tank as well as the gas and syrup connectors. This allows the operator of the system to change tanks without having to shut down the entire system. With this type of connector, push down on the connector while pulling up on the snap ring around the opening of the connector. Then simply pull the connector off the tank.

RACKING

Regardless if you are working on a B-I-B or Figal system, a place will be designated for placement of the product. A rack (or shelf) system affords systematic placement and complete usage of the beverage paid for. The B-I-B rack allows the boxes to lay properly for syrup dispersal. Please check with your B-I-B syrup supplier. Some boxes must be slightly tilted down, while others may be in virtually any position. The Figal tank rack keeps the newer and full tanks organized at one end of the beverage line with the partial tanks at the other.

B-I-B

The Bag-In-Box system refers to a plastic disposable bag. The B-I-B normally contains 5 gallons of syrup, however some locations offer 2-1/2 gallon B-I-B units. This plastic bag is then held inside a cardboard or other container. B-I-B systems are for post-mix applications only.

PUMPS

The syrup in a B-I-B system is delivered to the beverage system through gas operated pumps. These pumps extract the syrup out of the bags, forcing the syrup throughout the system.

AUTO BAG SELECTORS

These are used on higher volume B-I-B systems where two or more bags of the same product are connected to one pump and one system. An auto bag selector is essentially a valve that automatically changes from one bag (or series of bags) to another bag (or series of bags) of syrup as the bags empty, allowing a constant flow of product.

THIS PAGE INTENTIONALLY LEFT BLANK

Section 4 Maintenance

Cleaning

DISASSEMBLE FOR CLEANING

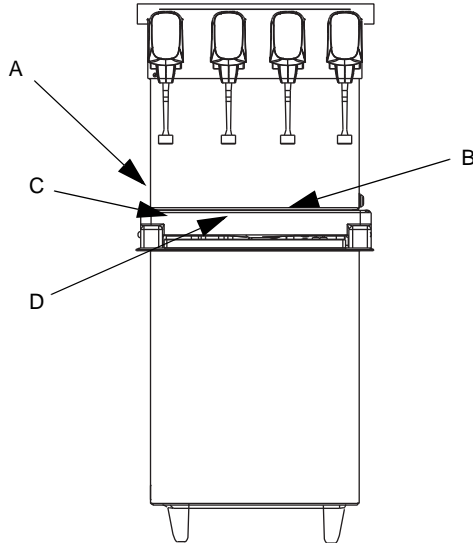

- A. Unplug the unit from power supply.
- B. Lift out the cup grid.
- C. Lift the drain pan straight up and pull it out.
- D. Remove the ice bin cover.

DAILY CLEANING

All cleaning must meet your local health department regulations. The following cleaning instructions are provided as a guide.

Caution

Use only warm soapy water to clean the exterior of the tower. Do not use solvents or other cleaning agents. Do not pour hot coffee into the drain pan. Pouring hot coffee down the drain pan can eventually crack the drain pan, especially if the drain pan is cold or still contains ice. DO NOT clean this unit using high pressure water jets or sprayers

Warning

Electric Shock Hazard

Unplug unit before servicing or cleaning.

Warning

When using cleaning fluids or chemicals, rubber gloves and eye protection should be worn.

Clean the exterior and drain pan:

1. Turn off the key switch located on either right or left side of the unit.
2. Lift the grid and remove it from the drain pan.
3. Using mild soap, warm water and a clean cloth, wipe the drain pan and splash panel. Then, rinse with clean, warm water. Allow plenty of warm (not hot) water to run down the drain of the drain pan, to remove syrup residue that can clog the drain opening.
4. Wash the grid, then rinse with clean water. Place the grid back in the drain pan.
5. Wash all exterior surfaces of the unit with warm water and a clean cloth. Wipe again with a clean, dry cloth.

Clean the dispensing valves:

6. Remove nozzles and diffusers from beverage valves.

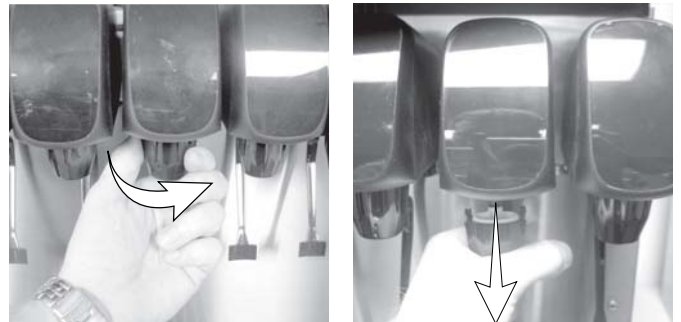

Nozzle Removal

7. Rinse nozzle and diffuser with warm, clean water.
8. Clean nozzles and diffusers with soapy water and a soft bristle brush.
9. Clean the underside of the beverage valves with warm, soapy water. Rinse with clean damp towel.
10. Replace nozzles and diffusers on valves.
11. Turn on the key switch.

Caution

Unplug unit before servicing or cleaning ice bin. Ice bin contains parts that can move at any time and will cause injury if hands are in the way.

**Warning**

When using cleaning fluids or chemicals, rubber gloves and eye protection must be worn.

MONTHLY CLEANING

Clean and sanitize the ice bin and cold plate:

1. Remove all ice from the ice bin.
2. Remove the ice bin strainer by lifting it straight up.
3. Prepare a mild detergent solution using warm (100°F) water.
4. Wash the ice bin using a sponge and the mild detergent solution.
5. Wash the cold plate using a soft, nylon bristle brush and the mild detergent solution.
6. Pour the remaining detergent solution in the drain pan and watch for obstruction of flow.
7. Rinse the ice bin and cold plate with clean water.
8. Prepare 2 gallons of sanitizing solution by mixing 1 ounce of household bleach (that contains 5.25% sodium hypochlorite) with 2 gallons of 120°F water. The mixture should not exceed 100 PPM of chlorine.
9. Sanitize the ice bin and cold plate with the sanitizing solution for at least 10 seconds.
10. Allow to air dry. Do not rinse.

CLEANING CHECKLIST

- Check CO₂ supply. If CO₂ supply is low, an arrow on the primary regulator gauge will point to a shaded area that reads “Low CO₂” or “Change CO₂ Cylinder.”
- Check syrup supply.
- Clean drain pan, grid, and splash panel.
- Clean the valve nozzles and diffusers.

PREVENTIVE MAINTENANCE

Preventative maintenance is a vital part of keeping your dispenser in top condition. Following the guidelines below will assist you in continued trouble-free operation of your unit.

1. Conduct daily maintenance of the machine.
2. Perform monthly maintenance of the machine.
3. Perform periodic maintenance and sanitizing of beverage system.
4. Do not overfill the dispenser bin with ice.
5. Do not allow the dispenser to sit for prolonged periods of non use with ice in the bin.
6. Do not allow ice to remain in the bin more than a day in order to prevent ice from freezing together and/or stagnant ice.

Contact MBE at 1-800-367-4233 for more information about our ProActive Maintenance Program.

Sanitizing

BEVERAGE SYSTEM CLEANING

Warning

Flush sanitizing solution from syrup system.
Residual sanitizing solution left in system could create a health hazard.

Warning

When using cleaning fluids or chemicals, rubber gloves and eye protection must be worn.

Sanitize the beverage system at initial start-up as well as regularly scheduled cleaning. The drain pan must be in place under soda valves, to carry away detergent and sanitizing agents that will be flushed through valves.

BAG-IN-BOX SYSTEM SANITATION

The procedure below is for the sanitation of one syrup circuit at a time. Repeat to sanitize additional circuits.

You will need the following items to clean and sanitize the Bag-in-Box (BIB) beverage system:

- Three (3) clean buckets
- Plastic brush or soft cloth
- Mild detergent
- Unscented bleach (5% Na CL O) or Commercial sanitizer
- Bag-In-Box bag connector

1. Prepare the following in the buckets:

- Bucket 1 — warm to hot tap water for rinsing.
- Bucket 2 — mild detergent and warm to hot water.
- Bucket 3 — mix a solution of unscented bleach (5% Na CL O) or commercial sanitizer and warm to hot water. Mixture should supply 100 PPM available chlorine (1/4 oz. bleach to 1 gallon water).

2. Disconnect the “syrup-line side” of the bag-in-box connector.



3. Rinse connector with warm tap water.

4. Connect syrup connector to BIB connector and immerse both into Bucket 1. A “bag-side” connector can be created by cutting the connector from an empty disposable syrup bag.

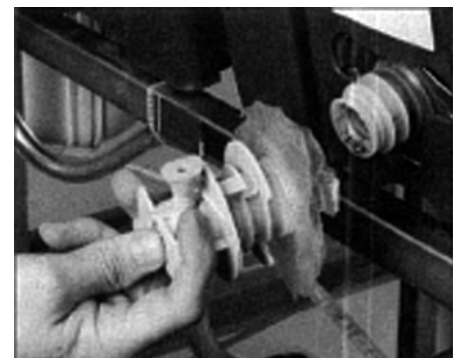
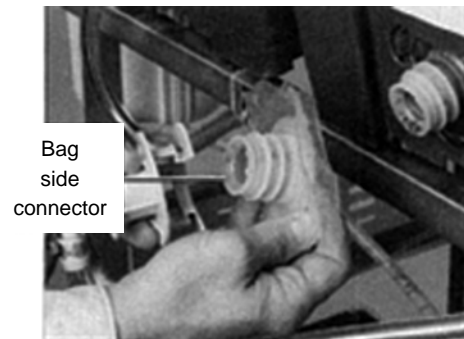

5. Draw rinse water through system until clean water is dispensed. Most beverage valves allow the syrup side to be manually activated by depressing the syrup pallet.
6. Connect Bucket 2 to system.
7. Draw detergent solution through system until solution is dispensed.
8. Repeat steps 2-7 until all syrup circuits contain detergent solution.

9. Allow detergent solution to remain in the system for 5 minutes.
 10. Connect Bucket 3 to system.
 11. Draw sanitizing solution through system until solution is dispensed.
 12. Repeat step 11 until all syrup circuits contain sanitizer solution.
 13. Allow sanitizer solution to remain in system for 15 minutes.
 14. Remove nozzles and diffusers from beverage valves.
 15. Scrub nozzles, diffusers and all removable valve parts (except electrical parts) with a plastic brush or a soft cloth and the detergent solution.
 16. Soak nozzles, diffusers and removable valve parts (except electrical parts) in sanitizer for 15 minutes.
 17. Replace nozzles, diffusers and valve parts.
 18. Connect Bucket 1 to system.
 19. Draw rinse water through system until no presence of sanitizer is detected.
 20. Attach syrup connectors to BIBs.
 21. Draw syrup through system until only syrup is dispensed.
 22. Discard first 2 drinks.
5. Connect detergent tank to the syrup line and draw detergent through the valve for two minutes. Then, allow remaining detergent to stay in the system for five minutes.
 6. Connect rinse tank to the syrup line. Draw clean rinse water through the valve until detergent is flushed from the system.
 7. Remove valve nozzle and diffuser as shown in Daily Cleaning instructions. Using a plastic brush or a soft cloth and warm water, scrub the nozzle, diffuser, bottom of the dispensing valve and cup lever, if applicable.
 8. Place removable valve parts (EXCEPT solenoids) in sanitizing solution for 15 minutes.
 9. Replace valve diffuser and nozzle on the beverage valve.
 10. Connect sanitizer tank to the syrup line and draw sanitizer through the valve for two minutes. Allow sanitizer to remain in the system for a minimum of 15 minutes.
 11. Reconnect syrup and carbonated water lines.
 12. Draw syrup through the lines to rinse the system. Discard drinks until at least two cups of satisfactory tasting beverage are dispensed through the valve.

FIGAL BEVERAGE SYSTEM

1. Prepare the following in three clean Figal tanks:
 - **Rinse tank** - fill with room temperature tap water.
 - **Detergent tank** - mix approved beverage system cleaner with warm water as directed.
 - **Sanitizing tank** - mix a solution of unscented bleach (5% Na CL O) or commercial sanitizer and warm to hot water. Mixture should supply 100 PPM available chlorine (1/4 oz. bleach to 1 gallon water).
2. Disconnect all product and water lines from product tanks and remove carbonator.
3. Locate the Figal syrup tank for the circuit to be sanitized. Remove both quick disconnects from the Figal syrup tank. Rinse quick disconnects in tap water.
4. Connect rinse tank to the syrup line. Draw clean rinse water through the valve until syrup is flushed from the system.

Caution

Before shipping, storing, or relocating this unit, syrup systems must be sanitized. After sanitizing, all liquids (sanitizing solution and water) must be purged from the unit. A freezing environment causes residual sanitizing solution or water remaining inside the unit to freeze, resulting in damage to internal components.

Section 5

Before Calling for Service

Checklist

If a problem arises during operation of your dispenser, follow the checklist below before calling service. Routine adjustments and maintenance procedures are not covered by the warranty.

DRINK TROUBLESHOOTING

Condition	Investigation	Check	Correction
Water only dispensing	No pressure	Regulator(s) out of adjustment	Check/adjust regulator(s).
		Out of CO ₂	Install fresh tank.
		Defective regulator(s)	Check/repair/replace regulator(s).
		CO ₂ line pinched, kinked or obstructed	Check/repair/replace CO ₂ line.
Syrup and CO ₂ only dispensing	Carbonator	No power	Check power supply. Plug in carbonator or reset breaker.
		Water supply	Make sure water is turned "on".
			Replace water filter.
			Check/clean/replace pump strainer.
			Check/clean/repair water check valve.
Check for frozen water line. Internal carbonator unit only.			
Defective carbonator	Check/repair/replace carbonator pump, motor, electrode or liquid level control.		
Syrup and plain water only dispensing setting	No pressure	Out of CO ₂	Install fresh tank.
		HP regulator out of adjustment	Adjust HP regulator to the proper setting.
		Defective HP regulator	Check/repair/replace HP regulator.
		CO ₂ line pinched, kinked or obstructed	Check/repair/replace CO ₂ line.
One valve will not dispense anything	Is there power to the valve?	Broken wire or loose connection	Replace/repair wire or connector.
		Bad microswitch	Replace microswitch.
Beverage dispensed is too sweet	Is the ratio (brix) of the drink correct?	Flow control out of adjustment	Adjust the flow control.
		Insufficient soda flow due to low carbonator pressure	Adjust CO ₂ pressure or change the tank.
		Low CO ₂ pressure due to leaks	Repair CO ₂ leaks.
		Obstruction in the water or soda line	Clean out the lines.
Beverage is not sweet enough	Is the ratio (brix) of the drink correct?	Flow control out of adjustment	Adjust the flow control.
		Soda flow too high	Reset CO ₂ pressure or replace regulator if necessary.
		Obstruction in syrup line	Clean out the syrup line.
Drinks are foaming	Are system pressures correct?	Over carbonation	Check CO ₂ supply. Reset pressure or replace regulator if necessary.
		Dirty lines/valves	Clean/sanitize entire system.
No water, syrup or gas dispensing	Is there power to the unit?	No power	Plug in unit or reset breaker.
		Power to control box	Replace fuse or control box.
	Is power coming through the key switch?	Key switch "off"	Turn switch "on".
		Key switch defective	Replace key switch.
	Is there power to the key switch?	No power through the transformer	Reset/replace transformer.

Pump Troubleshooting

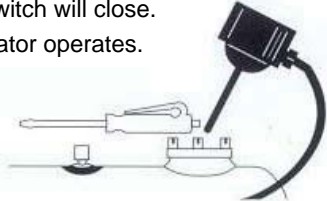
Problem	Possible Cause	Corrective Action
Pump motor does not shut off	Problem with probe or probe harness.	<ol style="list-style-type: none"> 1. Remove probe electronics. 2. Pass magnetic tip of screwdriver by lower end of tube extending from electronics package. 3. Reed switch will close. 4. Carbonator operates. 
Pump motor intermittent	Problem with probe or probe harness	
Pump motor does not pump	Water pressure from water source is not high enough	Verify water pressure leading into pump inlet is 40 psi minimum.



© 2008 Maniowoc
Continuing product improvements
may necessitate change of
specifications without notice.
Part Number 020002472 04/09



Maniowoc Beverage Equipment
2100 Future Drive
Sellersburg, IN 47172, USA
Ph: 812-246-7000 Fax: 812-246-7024
Visit us online at: www.manitowocfsg.com

