



Blended Beverage System

Technician's Handbook

This manual is updated as new information and models are released. Visit our website for the latest manual. www.manitowocfsg.com

Leader in Ice & Beverage Dispensers
Part Number STH034 3/13

Safety Notices

As you work on Manitowoc equipment, be sure to pay close attention to the safety notices in this handbook. Disregarding the notices may lead to serious injury and/or damage to the equipment.

Throughout this handbook, you will see the following types of safety notices:

Warning

Text in a Warning box alerts you to a potential personal injury situation. Be sure to read the Warning statement before proceeding, and work carefully.

Caution

Text in a Caution box alerts you to a situation in which you could damage the equipment. Be sure to read the Caution statement before proceeding, and work carefully.

Procedural Notices

As you work on Manitowoc equipment, be sure to read the procedural notices in this handbook. These notices supply helpful information which may assist you as you work.

Throughout this handbook, you will see the following types of procedural notices:

Important

Text in an Important box provides you with information that may help you perform a procedure more efficiently. Disregarding this information will not cause damage or injury, but it may slow you down as you work.

NOTE: Text set off as a Note provides you with simple, but useful, extra information about the procedure you are performing.

READ THESE BEFORE PROCEEDING:

Caution

Proper installation, care and maintenance are essential for maximum performance and trouble-free operation of your equipment. Visit our website www.manitowocfsg.com for manual updates, translations, or contact information for service agents in your area.

Important

Routine adjustments and maintenance procedures outlined in this handbook are not covered by the warranty.

Warning

Read this manual thoroughly before operating, installing or performing maintenance on the equipment. Failure to follow instructions in this manual can cause property damage, injury or death.

Warning

Do not use electrical appliances or accessories other than those supplied by Manitowoc for your ice machine model.

Warning

Two or more people or a lifting device are required to lift this appliance.

 **Warning**

This equipment contains high voltage electricity and refrigerant charge. Installation and repairs are to be performed by properly trained technicians aware of the dangers of dealing with high voltage electricity and refrigerant under pressure. The technician must also be certified in proper refrigerant handling and servicing procedures. All lockout and tag out procedures must be followed when working on this equipment.

 **Warning**

Do not damage the refrigeration circuit when installing, maintaining or servicing the unit.

 **Warning**

Do not operate equipment that has been misused, abused, neglected, damaged, or altered/modified from that of original manufactured specifications. This appliance is not intended for use by persons (including children) with reduced physical, sensory or mental capabilities, or lack of experience and knowledge, unless they have been given supervision concerning use of the appliance by a person responsible for their safety. Do not allow children to play with this appliance.

 **Warning**

All covers and access panels must be in place and properly secured, before operating this equipment.

 **Warning**

Do not obstruct machine vents or openings.

 **Warning**

Do not store gasoline or other flammable vapors or liquids in the vicinity of this or any other appliance.

 **Warning**

Do not clean with water jet.

 **Warning**

It is the responsibility of the equipment owner to perform a Personal Protective Equipment Hazard Assessment to ensure adequate protection during maintenance procedures.



Warning

When using electric appliances, basic precautions must always be followed, including the following:

- a. Read all the instructions before using the appliance.
- b. To reduce the risk of injury, close supervision is necessary when an appliance is used near children.
- c. Do not contact moving parts.
- d. Only use attachments recommended or sold by the manufacturer.
- e. Do not use outdoors.
- f. For a cord-connected appliance, the following must be included:
 - Do not unplug by pulling on cord. To unplug, grasp the plug, not the cord.
 - Unplug from outlet when not in use and before servicing or cleaning.
 - Do not operate any appliance with a damaged cord or plug, or after the appliance malfunctions or is dropped or damaged in any manner. Contact the nearest authorized service facility for examination, repair, or electrical or mechanical adjustment.
- g. Follow applicable lock out tag out procedures before working on equipment.
- h. Connect to a properly grounded outlet only.

This Page Intentionally Left Blank

Table of Contents

Safety Notices	2
Procedural Notices	3
Read These Before Proceeding:	4
General Information	
About Blend-In-Cup	15
Serial Number Location	15
Specifications	16
Dimensions	16
Product Delivery Location	20
Electrical	22
Air / CO2, Plain & Chilled Water Inlets ...	25
System Pressures	26
Drain Connections	27
Installation	
Step-by-Step Installation	29
Pre-installation Checklist	29
Connections	31
Checklist	33
Cleaning & Start-up	34
Demonstrate	36
Post Installation Checklist	37
Component Identification	
External	39
Left Side & Front	39
Front	39
Rear	40
Internal	41
Top Rear	41
Top Left	43
Top Right	44
Bottom Cabinet	45
Maintenance	
General Maintenance	47
Daily, Weekly Monthly	47
Door Gasket Maintenance	49
Drain Maintenance - Inside Lower Cabinet	50
Refrigerators	50

Stainless Steel Care & Cleaning	51
Doors/Hinges	52
Preventing Blower Coil Corrosion	53
Cleaning Kits	53
Daily Cleaning - Zone 1	54
Gather the following supplies	55
Blenders / Dispense Area Cleaning & Sanitizing	56
Weekly Cleaning - Zone 2	67
Gather the following supplies	68
Product Line Cleaning & Sanitizing	69
Sanitizing Ice Bin & Water Nozzles (Optional)	77
Blenders / Dispense Area Cleaning & Sanitizing	83
Drain Cleaning (Optional)	94
Monthly Cleaning - Zone 3	100
Gather the following supplies	100
Ice Maker / Bin Descaling, Cleaning & Sanitizing	102
Other Monthly Tasks	113
Biannual Descaling- Zone 3	115
Turn ON Descaling	116
Gather the following supplies	121
Ice Maker / Bin Descaling, Cleaning & Sanitizing	122
Turn OFF Descaling	133
Product Line Flush	137
Gather The Following Supplies	138
Manual Ice Machine Cleaning	150
For MB-8-1PP	150
Bin / Dispenser Descale, Clean, & Sanitize	154
Bin / Dispenser Disassembly Descale, Clean, & Sanitize	156
Annual Planned Maintenance	159

Operation

Touch Screens	161
Drink Selection Screen	162
Flavor Selection Screen	163
Size Screen	164
Main Menu Screen	168
Manager's Menu Screen	169
Product Inventory Screen	200
Cleaning Screen	204

Ice Making Sequence of Operation	206
Ice Machines R290 Refrigerant	206
Product Dispense Operation	207
Operation	207
Refrigerated Cabinet Operation	208
Normal Operation	208
Evaporator & Condenser Fan Motor Operation	209
Operation in the Clean/Sanitize cycle	210
Adaptive Defrost	210
High Temp Alarm	210
Thermistor Failure	210
Other Operations	211
Recommended Cups	211
Display Errors	213
Troubleshooting	
Control System	219
Will Not Run Diagnostics	219
Beverage System	221
Beverage System Diagnostics	221
Procedure to Clear Blocked Line	222
Ice System	224
Water System Checklist	225
ICE PRODUCTION & QUALITY CHECK	226
MB-8-1PP Ice Machine Electrical Troubleshoot-	
ing Flowchart	228
Refrigerated Cabinet	235
Reach-in temperature Out of Range	239
High Product Temperature	243
Refrigeration System Diagnostics	244
Analyzing Discharge Pressure or Temperature	
244	
Analyzing Suction Pressure or Temperature	
246	
Analyzing Discharge Pressure or Temperature	
248	
Analyzing Suction Pressure or Temperature	
250	
Procedure to Clear Blocked Line	252
How to Check Air/CO2 Pressure	255
How to Adjust Air/CO2 Pressure	259
How to Check Plain Water Pressure	263
Component Check Procedures	
Control System	265

ON/OFF Rocker Switch	265
Power Relay	267
Power Supply	269
UI (User Interface - Touchscreen)	271
SRB Board	275
Blender Control Board	279
CIP (Clean In Place) Relay Board	282
Beverage Components	284
Pressure Regulator - Water or CO2	284
Water Dispense Solenoid Valve	285
Syrup Solenoid Valve	286
Non Drip Valve	287
Product Pump	288
Step Motor	289
Blender Motor	290
Home Position Switch	291
Door Switches	292
Water Rinse Solenoid Valve	293
Ice Machine Components	294
High Pressure Cutout (HPCO) Control	294
Ice Maker Bin Level Relay	295
ICE CONDENSER COIL FAN	295
Infrared Ice Bin Control	296
Refrigerated Cabinet	297
Temperature Thermistor - Nozzle, Cabinet or De-frost	297
Evaporator Fan Motor	299
Duct Fan Motor	300
Condenser Fan Motor	300
Compressor Electrical Diagnostics	301
Compressor Drawing Locked Rotor	302
Diagnosing Capacitors	302
Filter-Driers	303

Charts

Total System Refrigerant Charge	305
Operational Charts	306
R290 Refrigerant - Ice Machine	306

Diagrams

Wiring Diagrams	307
R290 Ice Machine Refrigerant - Control System Wiring Diagram	308
R290 Ice Machine Refrigerant - Refrigeration Cabinet Wiring Diagram	309

Models: MB-8-1PP	309
R290 Ice Machine Refrigerant - Ice Maker & Ice Dispenser Wiring Diagram	310
Models: MB-8-1PP	310
R290 Ice Machine Refrigerant - Ice Maker Wiring Diagram	311
Models: MB-8-1PP	311
R290 Ice Machine Refrigerant - CIP BOard Wiring Diagram	312
Models: MB-8-1PP	312
.....	313
.....	314
Ice Machine Cleaning & Sanitizing Diagram	315
Models: MB-8-1PP	315
Ice Machine Cleaning & Sanitizing Diagram	316
Models: MB-8-1PP	316
Dispense System Diagram	317

General Information

About Blend-In-Cup

The Blend-In-Cup beverage system is a self-contained dispensing unit that allows the operator to make flavor combinations of blended and non-blended drinks. It holds product flavoring in a refrigerated reach-in base enclosure, has a refrigerated ice making machine and includes one or two mixing modules.

The operator controls and accesses the unit using a lighted touch screen. Icons on the drink selection screens represent the primary flavor combinations for the drinks. There are multiple drink size options. Menu changes and additions are uploaded using a USB mass storage device and the Menu Connect Software platform.

On-screen instructions also include operator procedures for cleaning/sanitizing, checking inventory, replacing product bags, selecting drink sizes and manually preparing drinks. Managers and technicians have access to menu/software updates, diagnostics and other service screens.

Serial Number Location

The Blend-In-Cup beverage system serial number is listed on the serial number decal affixed to the middle of the lower back panel. Another serial number decal is located on the right side of the machine.

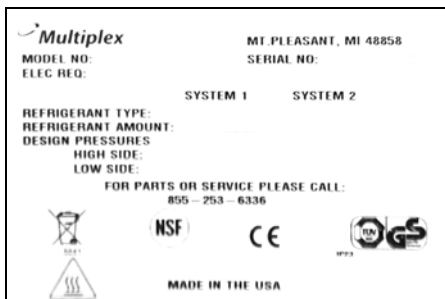

Sample Serial Tag

Specifications

DIMENSIONS

Warning

To avoid instability the installation area must be capable of supporting the weight of the equipment and a full bin of ice. Additionally the equipment must be level side to side and front to back.

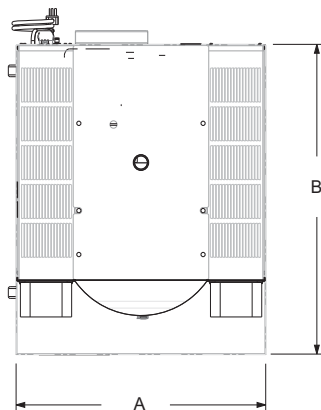

Elevation View

A	26.00" (66 cm)
B	32.82" (83 cm)

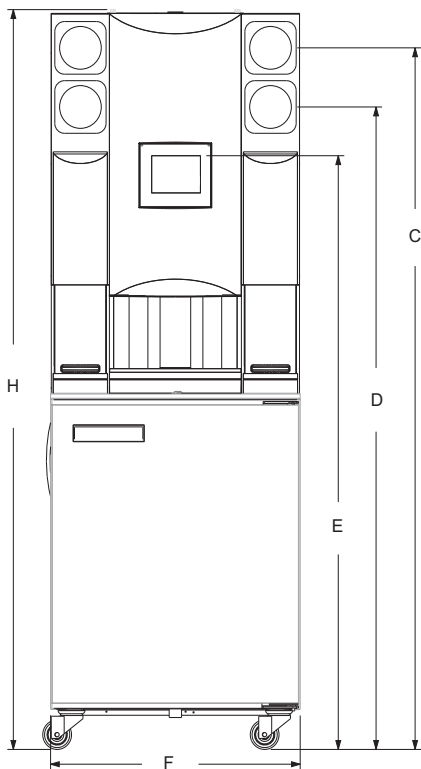

Elevation View

C	71.19" (181 cm)	F	26.00" (66 cm)
D	65.19" (166 cm)	H	75.07" (191 cm)
E	60.25" (153 cm)		

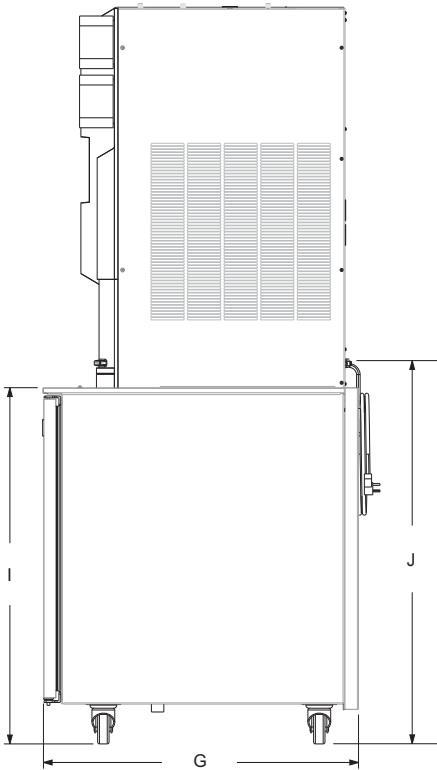

Side View

G	32.82" (83 cm)	J	39.09" (99 cm)
I	36.15" (92 cm)		

CAPACITY & WEIGHT

MB-8-1PP	Ice Capacity	H.P.	Refrigerant Charge	Max Product Bin Load	Shipping Weight	Empty Weight	Full Weight
Lower Cabinet	-	1/5	R-290 4.75 oz. (134.7 g)	19.8 lbs. (9 kg)	606 lbs (275 kg) Crated	492 lbs (223 kg) Unpacked No Ice/ Product	656 lbs (298 kg) With Ice/ Product
Ice Maker	310 lbs. (141 kg)/24 hr. Bin Storage 30 lbs (14 kg)	1/2	R-290 3.17 oz (90 g)	-			

PRODUCT DELIVERY LOCATION

The location selected for the Blend-In-Cup Beverage System must meet the following criteria.

- The air temperature must be at least 40°F (4°C), but must not exceed 90°F (32°C), climate class 4.
- The location must not be near heat-generating equipment or in direct sunlight and must be protected from weather.
- Plain or Chilled Inlet Water Temperature min/max = 40°F / 90°F (4°C / 32°C).
- Always use the water supply line supplied when installing this appliance. Never reuse an old supply line.
- Verify floor of install location is within 1/2" of level front to back, side to side.
- Keep equipment area clear of combustible material.



Warning

Carbon Dioxide (CO₂) displaces oxygen. Exposure to a high concentration of CO₂ gas causes tremors, which are followed rapidly by loss of consciousness and suffocation. If a CO₂ gas leak is suspected, particularly in a small area, immediately ventilate the area before repairing the leak. CO₂ lines and pumps must not be installed in an enclosed space. An enclosed space can be a cooler or small room or closet. This may include convenience stores with glass door self serve coolers. If you suspect CO₂ may build up in an area, venting of the B-I-B pumps and / or CO₂ monitors must be utilized.

Clearances

Top	18" (46 cm)
Sides	6" (15 cm)
Back	6" (15 cm)
Front	30" (76 cm)



Warning

Do not obstruct machine vents or openings.

Heat of Rejection

Model	Heat of Rejection BTU/h
All Single & Dual Spindle Base (Cabinet 1)	2100
Ice Maker (Cabinet 2)	5150

Operating Pressures PSIG

Air Temperature Entering Condenser Coil	Freeze Cycle	
	Discharge Pressure	Suction Pressure
70°F	150-170	17-23
90°F	180-200	18-24
110°F	225-245	21-27

ELECTRICAL



Warning

All wiring must conform to local, state and national codes.

Minimum Circuit Ampacity

The minimum circuit ampacity is used to help select the wire size of the electrical supply. (Minimum circuit ampacity is not the Blend-In-Cup Beverage System's running amp load.) The wire size (or gauge) is also dependent upon location, materials used, length of run, etc., so it must be determined by a qualified electrician.

Electrical Requirements

Refer to Blend-In-Cup Beverage System Model/Serial Plate for voltage/ampage specifications.



Caution

Operate equipment only on the type of electricity indicated on the specification plate.

Voltage

The standard voltage is 230VAC-50Hz. A dedicated electrical circuit is required, a power cord is provided with all units.

Some models are available in different voltages and may be equipped with a different plug, for details on each model always refer to the serial number tag to verify electrical data.

Minimum Circuit Amperage Chart

Important

Due to continuous improvements, this information is for reference only. Please refer to the serial number tag to verify electrical data. Serial tag information overrides information listed on this page.

Model Numbers	Voltage/Cycle/Refrigerant	Total Amps	Breaker Size (Max)
MB-8-1PP Dual Spindle	230-240/50/1 R290	6.4	20A

Grounding Instructions



Warning

The machine must be grounded in accordance with national and local electrical codes.

This appliance must be grounded. In the event of malfunction or breakdown, grounding provides a path of least resistance for electric current to reduce the risk of electric shock. This appliance is equipped with a cord having an equipment-grounding conductor and a grounding plug. The plug must be plugged into an appropriate outlet that is properly installed and grounded in accordance with all local codes and ordinances.

Bonding Instructions (230-240V 50 Hz Models Only)

This appliance must be connected to the potential equalization system in accordance with EN60335-1 and EN60335-2-75. A bonding lug is provided on the lower right front corner of the appliance.



Warning

This machine must be connected to the potential equalization system.

 **Warning**

When using electric appliances, basic precautions must always be followed, including the following:

- a. Read all the instructions before using the appliance.
- b. To reduce the risk of injury, close supervision is necessary when an appliance is used near children.
- c. Do not contact moving parts.
- d. Only use attachments recommended or sold by the manufacturer.
- e. Do not use outdoors.
- f. For a cord-connected appliance, the following must be included:
 - Do not unplug by pulling on cord. To unplug, grasp the plug, not the cord.
 - Unplug from outlet when not in use and before servicing or cleaning.
 - Do not operate any appliance with a damaged cord or plug, or after the appliance malfunctions or is dropped or damaged in any manner. Contact the nearest authorized service facility for examination, repair, or electrical or mechanical adjustment.
- g. Follow applicable lock out tag out procedures before working on equipment.
- h. Always unplug before replacing the lamp. Replace the bulb with the same type.
- i. Connect to a properly grounded outlet only. See Grounding Instructions.

AIR / CO₂, PLAIN & CHILLED WATER INLETS

Connections in the Rear of the Unit

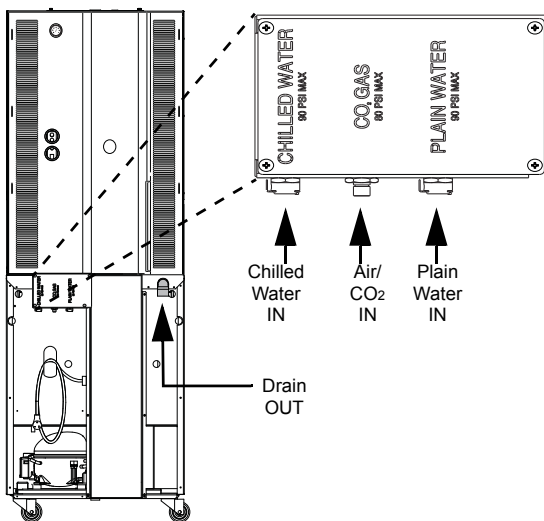

Warning

Connect to a potable water supply only.

- Use supplied 3/8" (.95 cm) panel-mounted hose barb and 6' (1.8 m) of beverage tubing to connect labeled coupling body fitting(s) on back of unit for each supply connection.
- Do not connect either water connection to a hot water supply. Be sure all hot water restrictors installed for other equipment are working. (Check valves on sink faucets, dishwashers, etc.)
- Install a water shut-off valve in the water line at the rear of the machine.
- Insulate water inlet lines to prevent condensation.

Hard Water

In areas where the water is highly concentrated with minerals the water should be tested by a water treatment specialist, and the recommendations of the specialist regarding filtration and/or treatment should be followed.

SYSTEM PRESSURES

Plain & Chilled Water

Important

Requires the pressure measurement to be taken only when rinse water is spraying (flowing conditions) in a blender chamber.

- Plain Water Supply Pressure must be capable of continuously supplying a minimum of 35 psi (241 kPa, 2.41 bar) during flowing conditions.
- If a separate chilled water source is used the chilled supply pressure needs to be a minimum of 35 psi (241 kPa, 2.41 bar) at no flow conditions.

Important

Water pressure affects the blender area cleaning, a water booster may be required if pressure is too low.

Air / CO₂

Important

Requires the pressure measurement to be taken only when a product pump is being activated (product pump during flow conditions).

- Supply must be capable of 35 psi (241 kPa, 2.41 bar) minimum during flowing conditions, measured at the unit Air/CO₂ regulator. See How to Check Air/CO₂ Pressure on page 255.
- Supply to the unit not to exceed 80 psi (345 / 552 kPa, 3.45 / 5.52 bar) maximum during no flow conditions.

DRAIN CONNECTIONS

- Connect supplied 1" ID hose to hose-barb connection on machine.
- Drain lines must have a 1.5 inch drop per 5 feet of run (2.5 cm per meter), and must not create traps.
- The floor drain must be large enough to accommodate drainage from all drains.
- An air gap is included in the design of the machine for backflow prevention, plumb to local code.

This Page Intentionally Left Blank

Installation

Step-by-Step Installation

These instructions are provided to assist the qualified installer. Contact your Manitowoc Foodservice Service Agent or call Manitowoc Foodservice for information regarding start-up services.

Important

Failure to follow these installation guidelines may affect warranty coverage.

PRE-INSTALLATION CHECKLIST

- Keep product bags in a cooler at least 24 hours prior to installation.
- Any damage should be noted and reported to the delivering carrier immediately.
- Check the lower portion of the unit to be sure casters are not bent.
- Visually inspect the refrigeration package, compressor compartment housing. Be sure lines are secure and base is still intact.
- Inspect installation location behind the BIC for electrical outlet location, CO₂, water hose fittings, and shutoff.
- Check voltage at outlet dedicated for BIC.
- Verify floor of install location is within 1/2" of level front to back, side to side and all casters are touching the floor.

 **Warning**

The mass of this appliance will allow it to move uncontrolled on an inclined surface. Adequate means must be provided to prevent uncontrolled movement at all times.

- Remove the side panels from the unit to make the board connections, Air/CO₂ and Water Regulator gauges accessible.
- Check that board connections are secure and did not vibrate loose during shipment.
- Remove steel top panel. Check that the black chute cover is sitting securely on the chute. The ice maker will not operate properly if it is out of place.
- Check that both micro switches are in line with the motor above the blenders.

CONNECTIONS

Connections in the Rear of the Unit

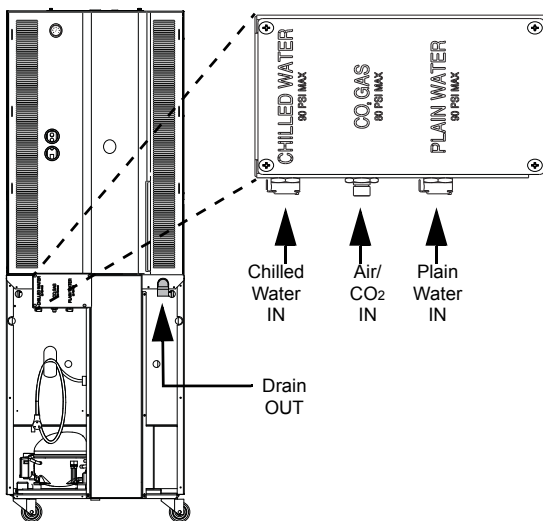

Important

Leave enough slack in the water/CO₂/drain lines to allow access to the rear of the machine without disconnecting the lines.

Water

1. Connect the Plain and Chilled (if used) water lines quick disconnect fittings and verify the water regulators are set to 35 psi (241 kPa, 2.41 bar). The Plain Water regulator is located on the left side of the unit and the Chilled Water regulator is located at the rear top. Final, during flow, settings will be made once the unit is in operation. See Cleaning & Start-up on page 34 and/or "How to Check Air/CO₂ Pressure" on page 255.

Air/CO₂

2. Connect Air/CO₂ line quick disconnect fitting. Verify the Air/CO₂ regulator on the left side of the unit is set to 35 PSI (241 kPa, 2.41 bar). Final during flow settings will be made once the unit is in operation.

Important

Regulators are factory set but will need to be checked and possibly adjusted under flowing conditions once the unit is operational.

3. Confirm correct orientation of Water and Air/CO₂ fittings.
4. Coil excess tubing and secure with tie straps.

Drain

5. Route drain line (minimum 1" ID) to drain, maintain a 2" (51 mm) air gap. Cut to proper length if needed (do not leave loops in drain). See Drain Connections on page 27

Electrical

6. If all electrical and grounding requirements have been followed (See Electrical Requirements on page 22 & See Grounding Instructions on page 23) proceed to insert electrical plug from BIC into wall receptacle.
7. Turn power and compressor switches, on the left hand side of the unit and the rear, to the ON position.
8. The touch screen should energize and inform the user to perform Zone 2 & 3 cleaning before the unit can be put into operation.

Important

Do not add product to the machine until cleaning and sanitizing are complete.

CHECKLIST

Review before proceeding to Cleaning & Start-up.

- Has all of the internal packing been removed?
- Have all of the electrical, water and CO₂ connections been made?
- Is there proper clearance around the machine for air circulation?
- Is the machine grounded / polarity correct?
- Has the machine been installed where the incoming water temperature will remain in the range of 40°F / 90°F (4°C / 32°C)?
- Have the regulators been set to 35 PSI (241 kPa, 2.41 bar)?
- Have the blender door sensor position(s) been checked?
- Have the Compressor and Power switches been turned to the ON position?

CLEANING & START-UP

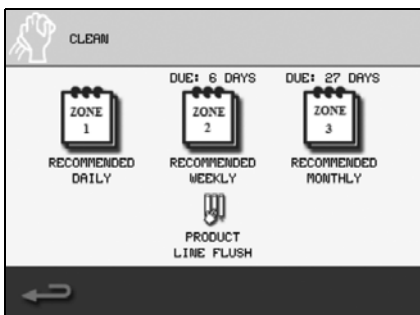

9. Clean and sanitize the Blend-In-Cup machine by following the on screen instructions, See Weekly Cleaning - Zone 2 on page 67, “Monthly Cleaning - Zone 3” on page 100, By doing so the following will have been completed;
- A. All beverage lines, ice maker, dispense area, and blender chambers, cleaned and sanitized.
 - B. Water run through the drain to verify it is draining properly.
 - C. Product bags retrieved from walk-in cooler, installed into the product bins and placed into their proper location in the cabinet. See Assigning Flavors on page 179 & “Procedure to Install a Product Bag” on page 202.
 - D. All product lines primed and ready for use.

NOTE: During the cleaning process is an ideal time to verify pressure regulator settings during flowing conditions.

- E. Verify the Plain Water regulator is set correctly during blend chamber cleaning, the regulator should maintain 35 psi (241 kPa, 2.41 bar) under flowing conditions.
- F. Verify the Air/CO₂ regulator is set correctly during product line cleaning, the regulator should maintain 35 psi (241 kPa, 2.41 bar) under flowing conditions.

NOTE: The Chilled Water Regulator needs to be a minimum of 35 psi (241 kPa, 2.41 bar) at no flow conditions.

Label

10. Add labels to product bins, put labels in correct place.
11. Add labels anywhere else on the unit required.

Software

12. Verify correct firmware is loaded. See Firmware Update Procedure on page 187.
13. Load recipes. See Recipe Loading Procedure on page 190.
14. Verify correct drinks and flavors are available.

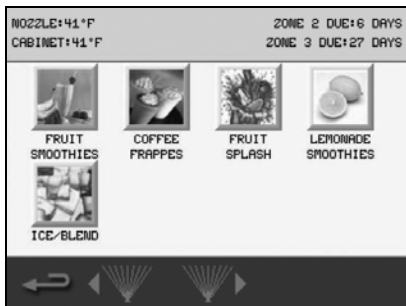

Calibrate

Important

Allow cabinet to reach operating temperature 36°F/2°C – 38°F/3°C before calibrating. Calibration will be inaccurate if performed above operating temperatures.

15. Product calibration can be performed once operating temperature has been reached. See Calibration Procedure on page 181 for step by step calibration instructions. Once completed the Blend-In-Cup machine is ready for use.
16. Reinstall top and side panels.
17. Push BIC into place.
18. Verify the unit is level and shim if necessary.

DEMONSTRATE

19. Using the Interface. See Touch Screens on page 161
20. How to make drink. See Procedure to Make a Drink on page 165.
21. Manager Menu options, using the default password "A". (The password can be changed.) See Manager's Menu Screen on page 169.
22. Set date and time to activate warranty. See Date & Time Setting on page 173
23. Complete start-up form, sign, and have store manager sign form. (Fax to number on form.)

POST INSTALLATION CHECKLIST

- Has the machine been properly sanitized?
- Has each flavor been installed and primed?
- Have the Air/CO2 and Plain water regulators been correctly set during flowing conditions?
- Is the machine cycling ON/OFF on the temperature control?
- Has the owner/operator been instructed regarding maintenance procedures?
- Has the owner/operator completed the warranty registration card?

This Page Intentionally Left Blank

Component Identification

External

LEFT SIDE & FRONT

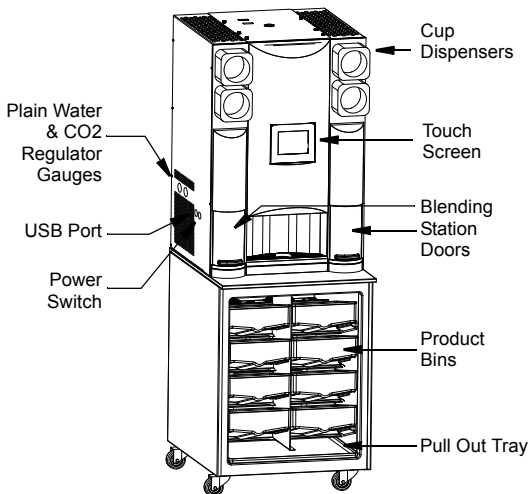

FRONT

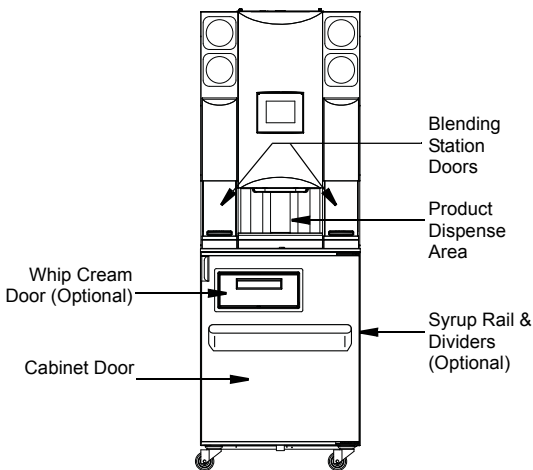

REAR

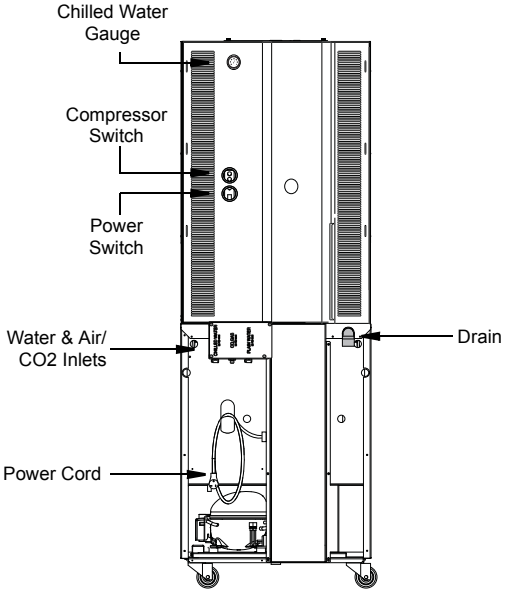

Internal

TOP REAR

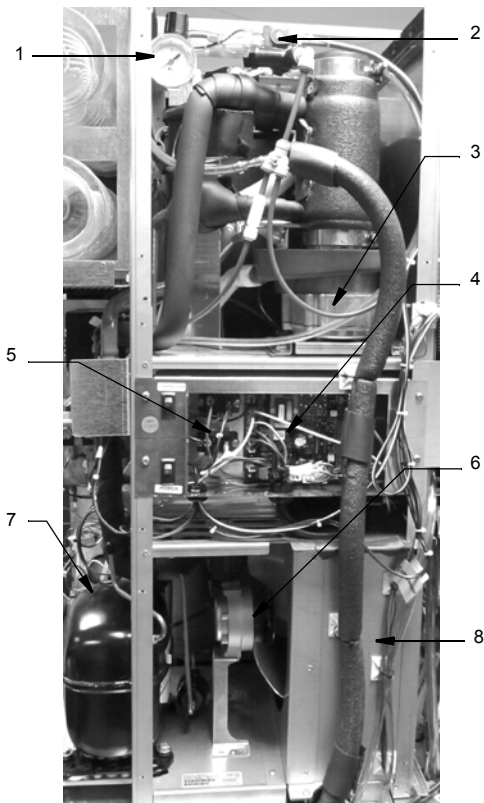

1. Chilled Water Regulator
2. Chilled Water Solenoid
3. Ice Maker Gear Box
4. Ice Maker Control
5. CIP Ice Maker Relay
6. Ice Maker Evaporator Fan
7. Ice Maker Compressor
8. Ice Maker Evaporator

Ice Machine Control Box

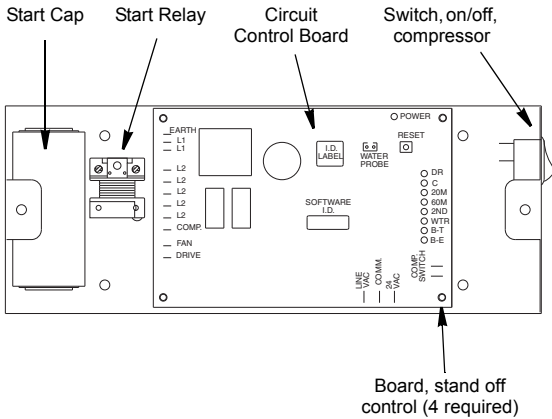

Ice Machine Components

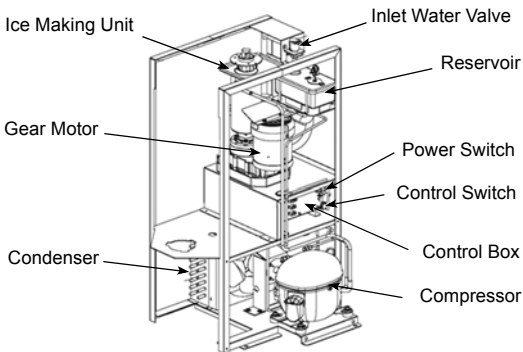

TOP LEFT

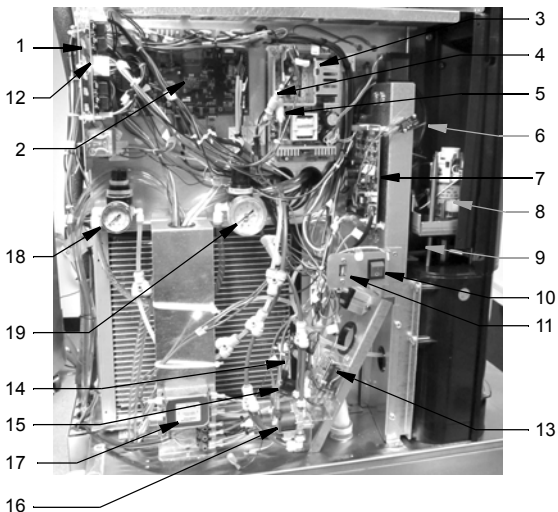

1. CIP Board
2. SRB
3. 24 V Power Supply
4. 4 Amp Fuse Power Supply
5. 4 Amp Fuse CIP System
6. Blender Home Position Micro Switch
7. Blender Board
8. Blender Motor
9. Linear Slide Motor
10. ON/OFF Switch
11. USB Port
12. Power Relay
13. Blender Door Relay
14. Blender 1 Rinse Nozzle Solenoid
15. Water Dispense Solenoid
16. Double Water inlet solenoid
17. EMC Filter
18. Air/C02 Regulator
19. Water Regulator

TOP RIGHT

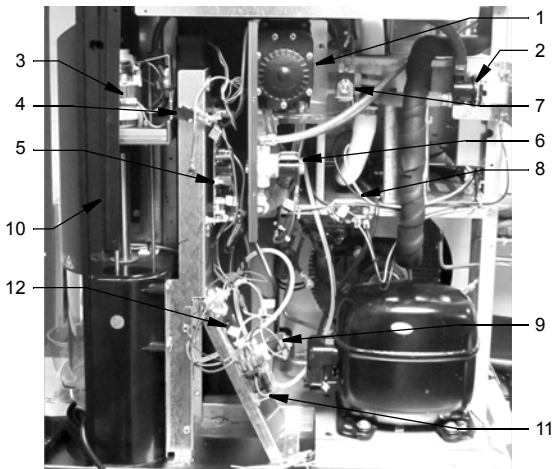

1. CIP Pump
2. Dump valve
3. Blender Motor
4. Blender Home Position Micro Switch
5. Mixer Board
6. CIP Ice bin solenoid
7. CIP CO₂/Air solenoid
8. Ice Maker Bin Relay
9. CIP Ice maker solenoid
10. Linear Slide Motor
11. Blender Door Relay
12. Blender 2 rinse nozzle solenoid

BOTTOM CABINET Pumps & Solenoids

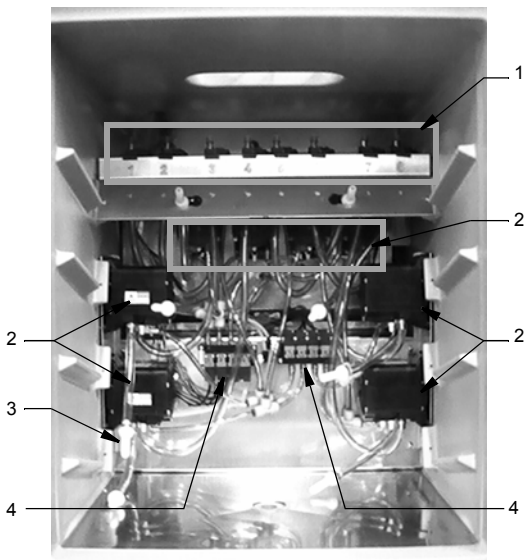

1. None Drip Valves (x8)
2. Product Pumps (x8)
3. Product Bag Nozzles (x8)
4. Solenoid Valves (x2)

Pump & Solenoid Numbering

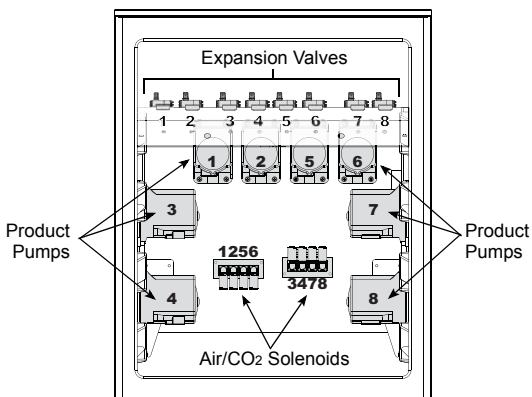

These numbers correspond to the product bins and inventory numbers in the User Interface.

Refrigeration



1. Duct Fan
2. Evaporator Coil
3. Evaporator Fans (2)
4. Cabinet Sensor

Maintenance

General Maintenance

This section covers common unit components and their care. The chart below is an overview of the maintenance that the end user and service technician should perform, and the frequency. These figures are the minimum required. If the Ice Machine is supplied with hard water, more frequent cleaning should be performed. If the condenser air filter is totally blocked, after one week, more frequent cleaning is recommended. (X = End User, S = Service Company)

DAILY, WEEKLY MONTHLY

Maintenance	Daily	Weekly	Monthly
Blender / Dispense Area Cleaning/ Sanitizing (Zone 1 Cleaning)	X		
Product Line Cleaning & Sanitizing (Zone 2 Cleaning)		X	
Drain Cleaning		X	
Clean Air Filters			X
Clean/Sanitize Ice Maker/Bin (Zone 3 Cleaning)			X
Descale Ice Maker/Bin (Zone 3 Cleaning)			
Clean Condenser Coil			
Inspect Ice Maker / Dispenser Parts			
Check Ice Quality	X	X	

QUARTERLY & BIANNUAL

Maintenance	3 Months	6 Months
Blender / Dispense Area Cleaning/ Sanitizing (Zone 1 Cleaning)		
Product Line Cleaning & Sanitizing (Zone 2 Cleaning)		
Drain Cleaning		
Clean Air Filters		
Clean/Sanitize Ice Maker/Bin (Zone 3 Cleaning)		
Descale Ice Maker/Bin (Zone 3 Cleaning)		S
Clean Condenser Coil	X	
Inspect Ice Maker / Dispenser Parts		
Check Ice Quality		

ANNUAL, SHUTDOWN & START-UP

Maintenance	Annual	After Prolonged Shutdown	At Start-up
Blender / Dispense Area Cleaning/ Sanitizing (Zone 1 Cleaning)			
Product Line Cleaning & Sanitizing (Zone 2 Cleaning)		X	S
Drain Cleaning		X	
Clean Air Filters		X	
Clean/Sanitize Ice Maker/Bin (Zone 3 Cleaning)		X	S
Descale Ice Maker/Bin (Zone 3 Cleaning)		S	
Clean Condenser Coil		X	
Inspect Ice Maker / Dispenser Parts	S	S	S
Check Ice Quality	S	S	S



Warning

Disconnect power to the unit before performing any service or maintenance functions.

Important

If the machine going to be shutdown for any length of time it is recommended to go through the Zone 2 - Weekly Cleaning both prior to turning off the unit and when returned to use.

If the unit is turned off the product will no longer be kept cool in the refrigeration cabinet, remove all product bags and keep refrigerated to prevent spoilage.

DOOR GASKET MAINTENANCE

Door gaskets require regular cleaning to prevent mold and mildew buildup and also to retain the elasticity of the gasket. Gasket cleaning can be done with the use of warm soapy water. Avoid full strength cleaning products on gaskets as this can cause them to become brittle and crack. Never use sharp tools or knives to scrape or clean the gasket. Gaskets can be easily replaced and do not require the use of tools or an authorized service person. The gaskets are “Dart” style and can be pulled out of the groove in the door and new gaskets can be “pressed” back into place.

DRAIN MAINTENANCE - INSIDE LOWER CABINET

Each unit has a drain located inside the unit that removes the condensation from the evaporator coil and routes it to an external condensate evaporator pan. Each drain can become loose or disconnected during normal use. If you notice water accumulation on the inside of the unit, be sure the drain tube is connected to the evaporator drain pan. If water is collecting underneath the unit, make sure the end of the drain tube is in the condensate evaporator in the machine compartment. The leveling of the unit is important as the units are designed to drain properly when level. Be sure all drain lines are free of obstructions.

REFRIGERATORS

Warning

Do not damage the refrigeration circuit when installing, maintaining or servicing the unit.

The interior and exterior can be cleaned using soap and warm water. If this isn't sufficient, try ammonia and water or a nonabrasive liquid cleaner. When cleaning the exterior, always rub with the "grain" of the stainless steel to avoid marring the finish. Do not use an abrasive cleaner because it will scratch the stainless steel and can damage the breaker strips and gaskets.

STAINLESS STEEL CARE & CLEANING

To prevent discoloration or rust on stainless steel, several important steps need to be taken. First, we need to understand the properties of stainless steel. Stainless steel contains 70-80% iron, which will rust. It also contains 12-30% chromium, which forms an invisible passive film over the steel's surface, which acts as a shield against corrosion. As long as the protective layer is intact, the metal is still stainless. If the film is broken or contaminated, outside elements can begin to break down the steel and begin to form discoloration or rust. Proper cleaning of stainless steel requires soft cloths or plastic scouring pads.

Important

Never Use Steel Pads, Wire Brushes or Scrapers!

Cleaning solutions need to be alkaline based or non-chloride cleaners. Any cleaner containing chlorides will damage the protective film of the stainless steel. Chlorides are also commonly found in hard water, salts, and household and industrial cleaners. If cleaners containing chlorides are used, be sure to rinse repeatedly and dry thoroughly. Routine cleaning of stainless steel can be done with soap and water. Extreme stains or grease should be cleaned with a non-abrasive cleaner and plastic scrub pad. Always rub with the grain of the steel. There are stainless steel cleaners available which can restore and preserve the finish of the steel's protective layer. Early signs of stainless steel breakdown are small pits and cracks. If this has begun, clean thoroughly and start to apply

stainless steel cleaners in attempt to restore the passivity of the steel.

 **Caution**

Never use an acid based cleaning solution! Many food products have an acidic content, which can deteriorate the finish. Be sure to clean the stainless steel surfaces of ALL food products. Common items include: tomatoes, peppers and other vegetables.

 **Caution**

Never use a high-pressure water wash for this cleaning procedure as water can damage the electrical components located near or at the condenser coil.

DOORS/HINGES

Over time and with heavy use doors and hinges may become loose. If this happens tighten the screws that mount the hinge brackets to the frame of the unit. Loose or sagging doors can cause the hinges to pull out of the frame, which may damage both the doors and the hinges. In some cases this may require trained & qualified service agents or maintenance personnel to perform repairs.

NOTE: Do not place hot pans on/against the blue ABS liner. Do not throw items into the storage area. Failure to follow these recommendations could result in damage to the interior of the cabinet or to the blower coil. Overloading the storage area, restricting the airflow, and continuous opening and closing of the doors and drawers will hamper the unit's ability to maintain operational temperature.

PREVENTING BLOWER COIL CORROSION

Immediately wipe up all spills.

CLEANING KITS

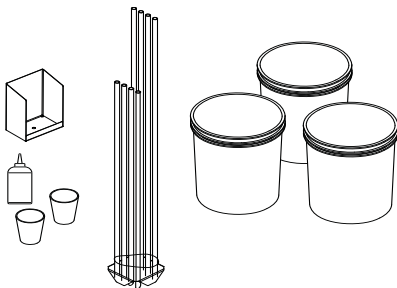

Complete cleaning kits are available for single spindle (part number 000-BIC-001R) and dual spindle (part number 000-BIC-001Q) units. These kits include the following;

- (3) three 5 gallon buckets
- Bucket labels for Wash, Rinse, & Sanitizing
- Red & Blue cups for blender cleaning
- Squeeze Bottle
- Dispense Area Shield
- Tubing Manifold for product line cleaning

Daily Cleaning - Zone 1

NOTE: The following procedures are the basic daily cleaning instructions, on screen instructions can vary depending on the recipe that was created with the MenuConnect program. * *These items are optional and may not be displayed on all EasyTouch screens during ZONE 1 Cleaning.*

- Time to complete - 15 minutes
1. Cycle touch screen to the Main Menu and select the Cleaning Icon.

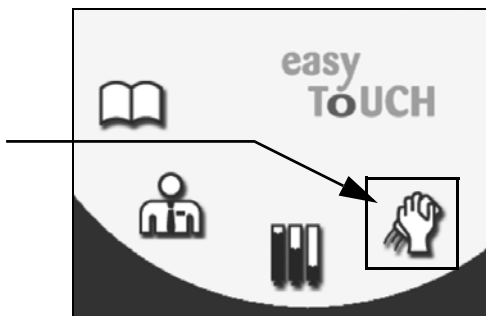

Main Menu Touch Screen



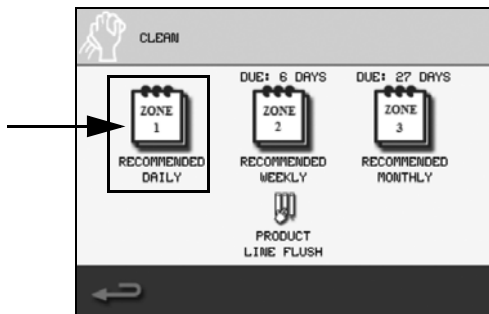

2. In the cleaning screen select the Zone 1 Icon.



Cleaning Touch Screen

GATHER THE FOLLOWING SUPPLIES

Follow the on screen instructions and gather the following supplies;

Clean towels (* Cloths)	
Spray Cleaner & Detergent Solution (Approved dish detergent solution)	
Spray Sanitizer & Solution (Approved sanitizer solution that provides 100 ppm available chlorine.)	
Red & Blue Cleaning Cups (1 of each per blender station)	
* Scoop, Cleaning Brush, Gloves & Safety Glasses	
<i>* These items are optional and may not be displayed on all EasyTouch screens.</i>	

NOTE: If other cleaners are used, it is possible they will not clean or sanitize your machine to NSF standards.

- Press the down arrow to continue

BLENDERS / DISPENSE AREA CLEANING & SANITIZING

Grate Removal / Blender Station Wash

1. Follow the on screen instructions;
 - * Put on gloves & safety glasses.
2. Remove grate from the mixer station(s)
 - Press the down arrow to continue

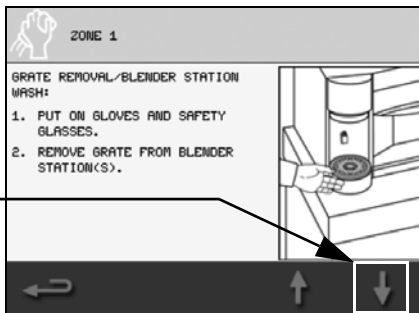

Blend Chamber Grate Removal

3. Spray all surfaces inside blender station with cleaning solution.
 - * Then scrub thoroughly with approved cleaning brush.
4. Thoroughly wipe down all surfaces of mixer station & repeat for the other side if applicable.
 - Press the down arrow to continue.

Dispensing Area Cleaning

1. Remove center grate from dispensing area.

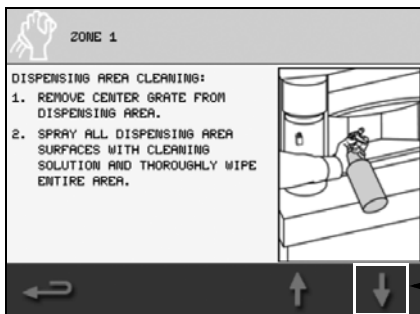

Dispense Area Screen

2. Spray all dispensing area surfaces with cleaning solution.
 - * Then use approved cleaning brush to thoroughly scrub area.
 - Press the down arrow to continue.
3. Thoroughly spray each individual dispense nozzle with cleaning solution and apply cleaner to each individual dispensing valve.
 - * Then use approved cleaning brush to carefully scrub area.
4. Thoroughly wipe all dispense valves and dispense area with a clean towel.
 - Press the down arrow to continue.

Mixer Door Removal

1. Slightly open mixer door.

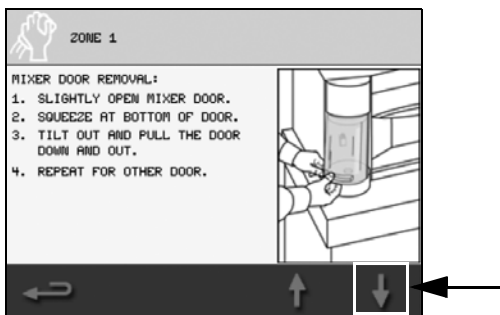

Mixer Door Removal Screen

2. Squeeze at bottom of door.
3. Tilt out and pull the door down and out.
4. Repeat for other door if applicable.
 - Press the down arrow to continue.

Blender Station Wash

1. Completely spray blender station with cleaning solution.

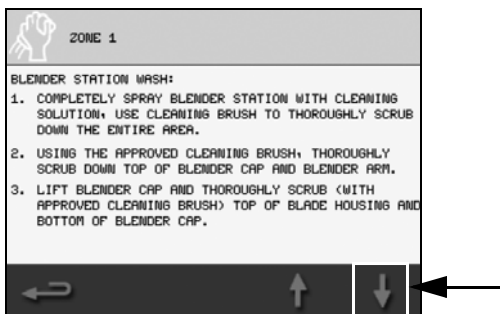

Blender Station Wash Screen

- * Use cleaning brush to thoroughly scrub down the entire area.
 - * Using the approved cleaning brush, thoroughly scrub down top of blender cap and blender arm
2. Lift blender cap and thoroughly wipe down top of blade housing and bottom of blender cap.
 - * Scrub (with the approved cleaning brush) top of blade housing and bottom of blender cap.
 - Press the down arrow to continue.
 3. Thoroughly spray with sanitizer solution.
 - * Using the approved cleaning brush to scrub entire blender assembly.
 4. Repeat for other side if applicable.
 - Press the down arrow to continue.

Reinstall Grate(s)/Door(s)

1. Take all grate(s) and door(s) to sink to wash and sanitize.

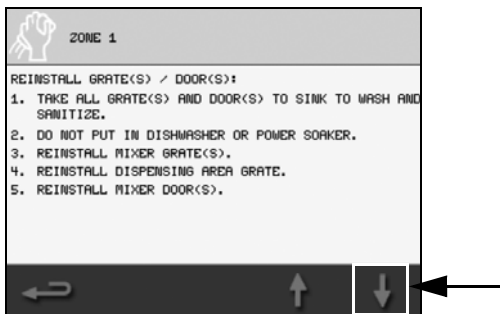

Grates & Doors Screen

Important

Never Use Steel Pads, Wire Brushes, Scrapers, or any Abrasive Cleaners / Scouring Pads!

2. Do not put in dishwasher or power soaker.
3. Reinstall mixer grate(s).
4. Reinstall dispensing area grate.
5. Reinstall mixer door(s)
 - Press the down arrow to continue.

Blender Wash

1. Place blue cleaning cup(s) with wash solution in blender station(s) and close the blender doors.
 - Use approved dish detergent solution)

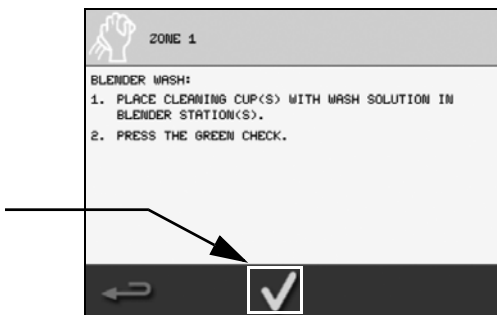

Blender Wash Screen

2. Press the green check to begin.

The blenders will lower into the wash solution and spin to clean. WASHING will display on the screen.

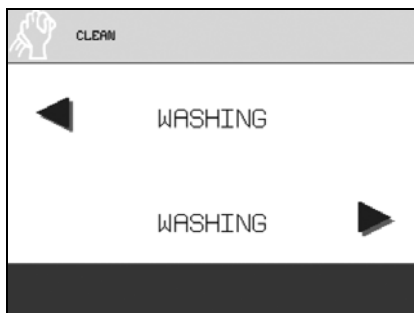

Washing Screen

Follow the on screen instruction, when prompted remove the blue cup(s) and pour wash solution down the drain.



Remove Cup Screen

Close the blender door(s) and RINSING will display on the screen while the machine rinses the blenders.

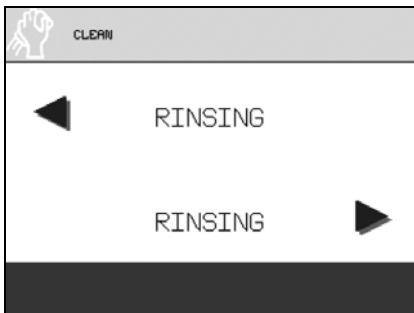

Rinse Cup Screen

Finished will display on the screen then progress to the Blender Sanitizing screen.

Blender Sanitizing

1. Place red sanitizing cup(s) with sanitizing solution in blender station(s) and close the blender doors.
 - Use approved sanitizer solution that provides 100 ppm available chlorine.

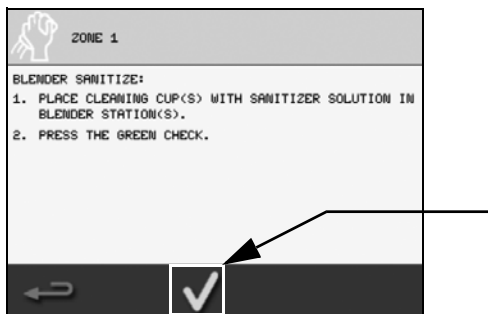

Blender Sanitizing Screen

2. Press the green check to begin.

The blenders will lower into the wash solution and spin to sanitize. SANITIZE will display on the screen.

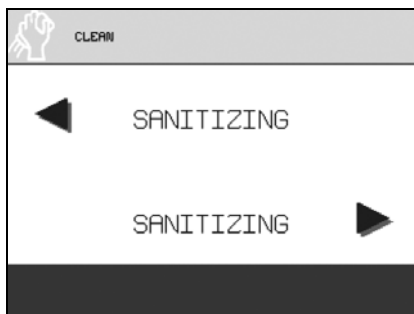

Washing Screen

Follow the on screen instruction, when prompted remove the red cup(s) and pour sanitizing solution down the drain.

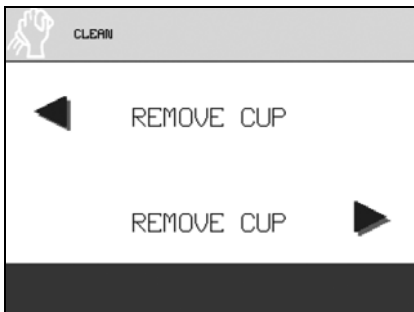

Remove Cup Screen

Close the blender door(s) and RINSING will display on the screen while the machine rinses the blenders.

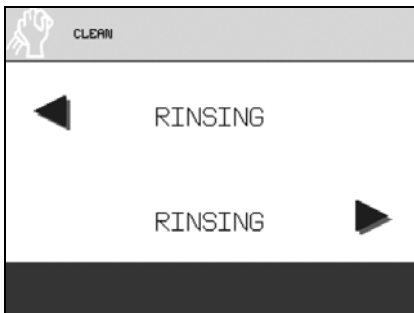

Rinse Cup Screen

Finished will display on the screen then progress to the Blender Station Sanitizing screen.

Blender Station Sanitizing

1. Completely spray blender station with cleaning solution.
 - * Use cleaning brush to thoroughly scrub down the entire area.

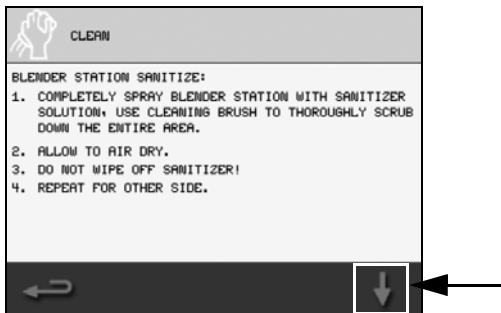

Blender Station Sanitizing Screen

2. Allow to air dry, **Do not wipe off sanitizer!**
3. Repeat for other side if applicable.
 - Press the down arrow to continue.

Dispensing Area Sanitizing

1. Thoroughly spray each individual dispense nozzle with sanitizer solution.

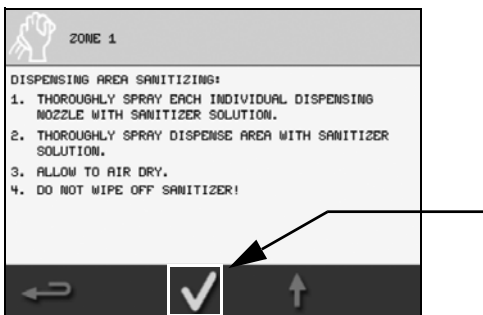

Dispense Area Sanitizing Screen

2. Thoroughly spray dispense area with sanitizer solution.
3. Allow to air dry, **Do not wipe off sanitizer!**
 - * Remove gloves & safety glasses
 - Press the green check to signify you have completed the Zone 1 Daily Cleaning.

Weekly Cleaning - Zone 2

NOTE: The following procedures are the basic weekly cleaning instructions, on screen instructions can vary depending on the recipe that was created with the MenuConnect program or options chosen in the Managers Menu. * *These items are optional and may not be displayed on all EasyTouch screens during ZONE 2 Cleaning.*

- Time to complete - 1 hour
1. Cycle touch screen to the Main Menu and select the Cleaning Icon.

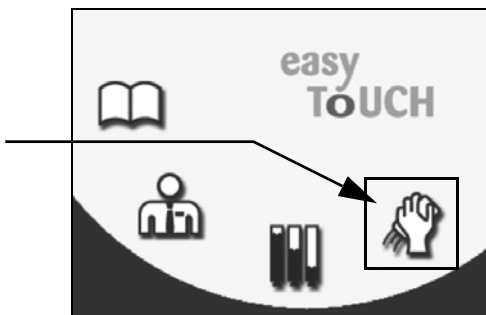

Main Menu Touch Screen

2. In the cleaning screen select the Zone 2 Icon.

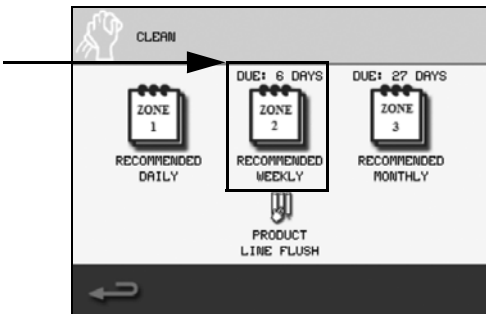









Cleaning Touch Screen

NOTE: Failure to complete the weekly cleaning sequence entirely will not reset the weekly cleaning timer and will require the process to be repeated.

GATHER THE FOLLOWING SUPPLIES

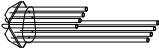
Follow the on screen instructions and gather the following supplies;

<p>Clean towels (* Cloths)</p>	
<p>Spray Cleaner & Detergent Solution (Approved dish detergent solution)</p>	
<p>Spray Sanitizer & Solution (Approved sanitizer solution that provides 100 ppm available chlorine.)</p>	
<p>Red & Blue Cleaning Cups (1 of each per blender station)</p>	
<p>Set of Three (3) Cleaning Buckets (Wash, Rinse & Sanitize Solutions)</p>	
<p>Splash Shield</p>	
<p>Cleaning Manifold</p>	
<p>* Drain cleaner & Dispenser</p>	
<p>* Scoop, Cleaning Brush, Gloves & Safety Glasses</p>	
<p><i>* These items are optional and may not be displayed on all EasyTouch screens.</i></p>	

NOTE: If other cleaners are used, it is possible they will not clean or sanitize your machine to NSF standards.

- Press the down arrow to continue

PRODUCT LINE CLEANING & SANITIZING

Prepare Cleaning Solutions

1. Follow the on screen instructions;

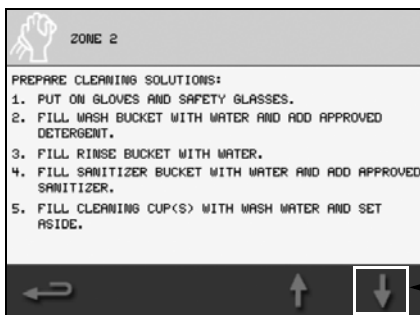

Prepare Solutions Screen

- * Put on gloves & safety glasses.
2. Fill wash bucket with water and add detergent. (Approved dish detergent solution.)
 3. Fill rinse bucket with water.
 4. Fill sanitizer bucket with water and add approved sanitizer. (Approved sanitizer solution that provides 100 ppm available chlorine.)
 5. Fill blue cleaning cup(s) with wash solution and set aside. (Approved dish detergent solution.)
 - Press the down arrow to continue.
 6. Fill red sanitizing cup(s) with sanitizing solution and set aside. (Approved sanitizer solution that provides 100 ppm available chlorine.)
 - Press the down arrow to continue.

Washing Instructions

1. Remove grate from center dispensing area.

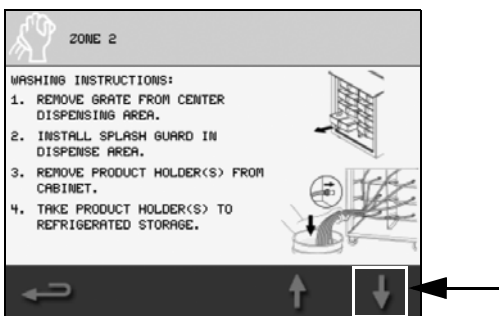

Washing Instructions Screen

2. Install splash guard in dispense area.
3. Remove product holders from cabinet.
4. Take product holders to refrigerated storage.
 - Press the down arrow to continue
5. Spray and wipe each bib connector and area with cleaner.
6. Spray each bib connector and area with sanitizer.
7. Connect a cleaning hose to each product nozzle.
 - Press the down arrow to continue
8. Place cleaning manifold in wash bucket.
9. Press the green check to begin cleaning the lines.

This will automatically send the wash solution through each line (slot), displaying the progress on the screen, 30 seconds per slot.

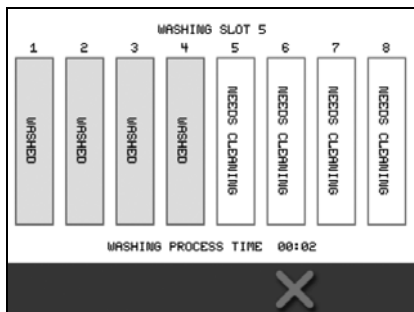

Product Line Washing Screen

When washing has completed the Rinsing Instructions Screen will appear automatically.

Rinsing Instructions

1. Remove cleaning manifold from wash bucket.

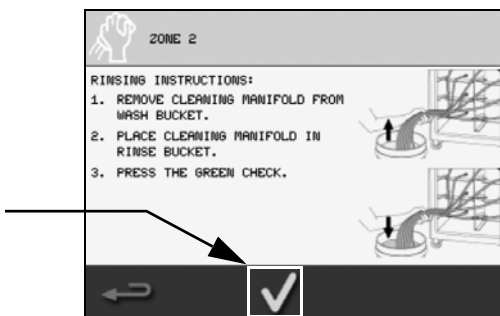

Rinsing Instructions Screen

2. Place cleaning manifold in rinse bucket.
3. Press the green check begin rinsing the lines.

This will automatically send the rinse solution through each line (slot), displaying the progress on the screen, 30 seconds per slot.

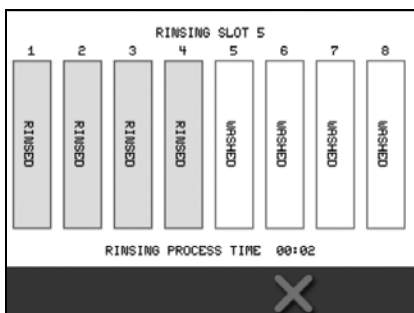

Product Line Rinsing Screen

When rinsing has completed the Sanitization Instructions Screen will appear automatically.

Sanitization Instructions

1. Remove cleaning manifold from rinse bucket.

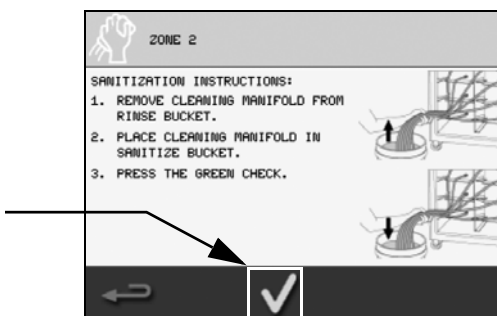

Sanitizing Instructions Screen

2. Place cleaning manifold in sanitize bucket begin sanitizing the lines.
3. Press the green check begin sanitizing the lines.

This will automatically send the sanitizing solution through each line (slot), displaying the progress on the screen, 30 seconds per slot.

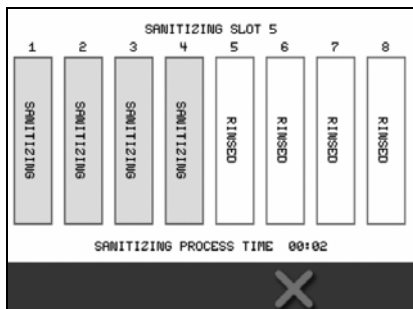

Product Line Sanitizing Screen

When sanitizing has completed the Purging Instructions Screen will appear automatically.

Purging Instructions

1. Disconnect the cleaning hoses from the product nozzles.

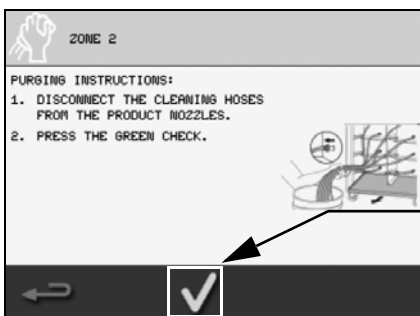

Sanitizing Instructions Screen

2. Press the green check begin purging the lines.

Air is pushed through each line (slot) blowing out any remaining liquid, displaying the progress on the screen, 30 seconds per slot.

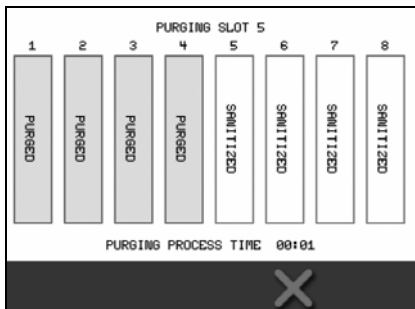

Product Line Purging Screen

When purging has completed the Reinstall Inventory Screen will appear automatically.

Reinstall Inventory

1. Retrieve product holders from refrigerated storage.

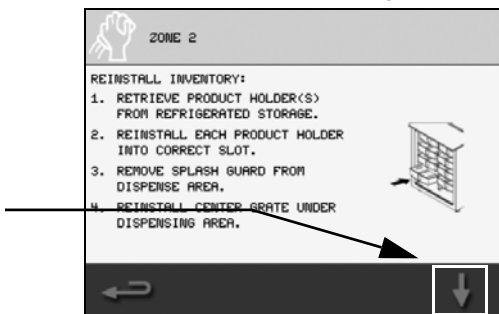

Reinstall Inventory Screen

2. Reinstall each product holder into correct slot.
3. Remove splash guard from dispense area.
4. Reinstall center grate under dispensing area.
 - Press the down arrow to continue.
5. Place a large cup under dispensing nozzles
6. Press the green check to prime each line.

This will automatically prime each line with product. The screen will read Priming Slot X. Each slot will change from Purged to Clean.

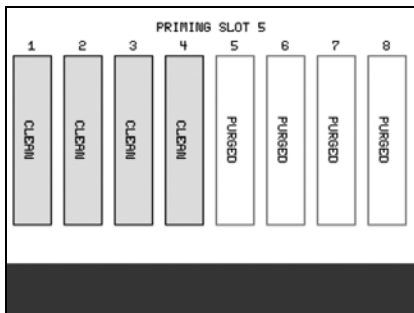

Product Line Purging Screen

When priming has completed the Prime Completion Screen will appear automatically.

Auto Prime Complete

1. Remove and dispose of large cup with primed product.

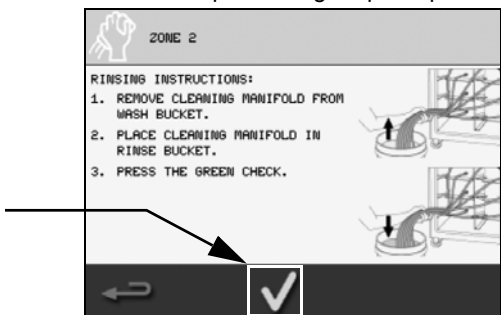

Prime Completed Screen

2. Press the green check to continue to the Sanitizing Ice Bin & Water Nozzles screen, if this feature is not turned on in the Managers Menu proceed to "Blenders / Dispense Area Cleaning & Sanitizing" on page 83.

SANITIZING ICE BIN & WATER NOZZLES (OPTIONAL)

* These steps will only display during the ZONE 2 Cleaning on units with this feature turned on in the Managers Menu. If this feature is not active the interface will automatically proceed to “Blenders / Dispense Area Cleaning & Sanitizing” on page 83.

Gather the Following Supplies

Cleaning Buckets - Set of Three (3)	
Cleaning Hose * (Located below product bins)	
Ice Removal Chute	
Splash Guard	
Sanitizing Solution (Approved sanitizer solution that provides 100 ppm available chlorine.)	
* Scoop, Cleaning Brush, Gloves & Safety Glasses	
<i>* These items are optional and may not be displayed on all EasyTouch screens.</i>	

NOTE: If other cleaners are used, it is possible they will not clean or sanitize your machine to NSF standards.

- Press the down arrow to continue

Removal of Ice

Follow the on screen instructions;

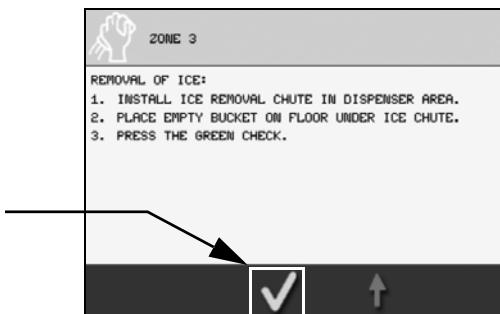

Ice Removal Screen

1. Install ice removal chute in dispenser area.
2. Place empty bucket on floor under ice chute.
3. Press the green check to begin dispensing ice.
 - The Ice Dispensing Timer Screen will display, the machine will empty of ice.



Ice Dispense Timer Screen

Ice Disposal

1. Dispose of ice in the bucket and set aside.

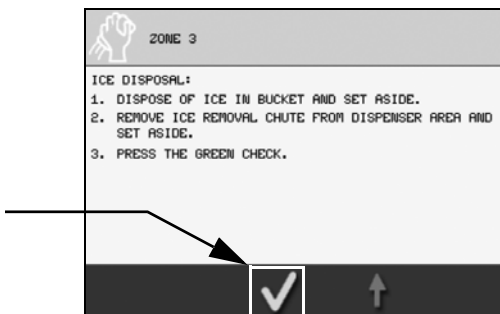

Ice Disposal Screen

2. Remove ice removal chute from the dispenser area and set aside.
3. Press the green check.

Sanitizing Ice Bin & Water Nozzles Prep

1. Install splash guard in dispense area.

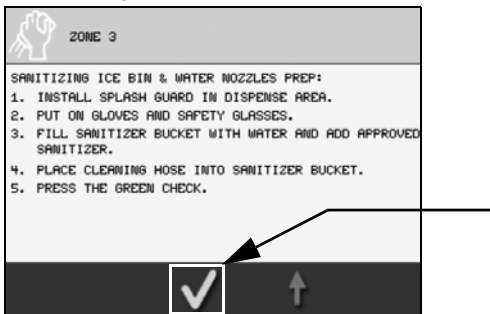

Bin & Nozzles Prep Screen

- * Put on gloves and safety glasses.
2. Fill sanitizer bucket with water and add sanitizer. (Use approved sanitizer solution that provides 100 ppm available chlorine.)
 3. Place cleaning hose into the sanitizer bucket.
 4. Press the green check to begin sanitizing the ice bin and water nozzles.
- The Sanitizing Timer Screen will display, and count down during the sanitizing process.

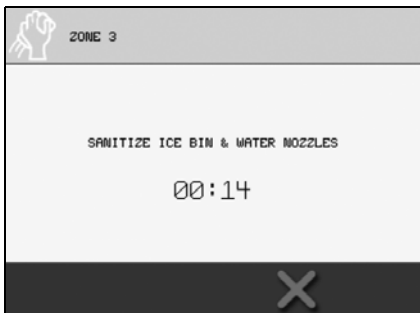

Sanitizing Timer Screen

Discard Sanitizer

1. Install cleaning hose into the bottom of the refrigerated cabinet.

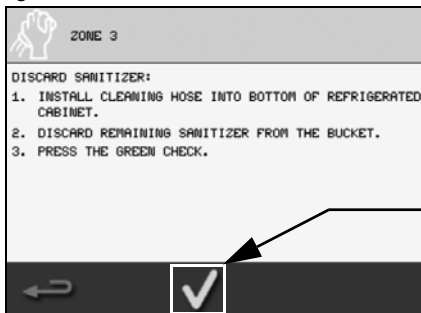

Discard Sanitizer Screen

2. Discard remaining sanitizer from the bucket.
3. Press green check to continue.

Rinsing Sanitizer Prep

1. Install splash guard in the dispense area.

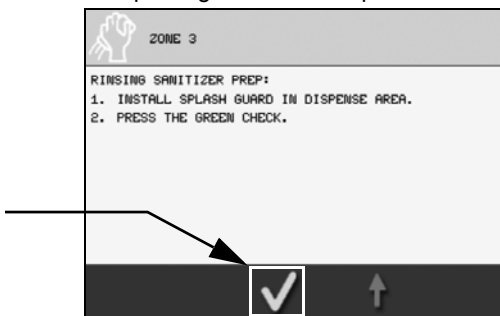

Plain Water Rinse

2. Press the green check to begin the plain water rinse cycle.



Rinse Timer Screen

- The Rinse Timer Screen will display, and count down during the rinsing process then automatically proceed to the Grate Removal/Blender Station Wash Screen.

BLENDERS / DISPENSE AREA CLEANING & SANITIZING

Grate Removal / Blender Station Wash

1. Remove grate from the mixer station(s)

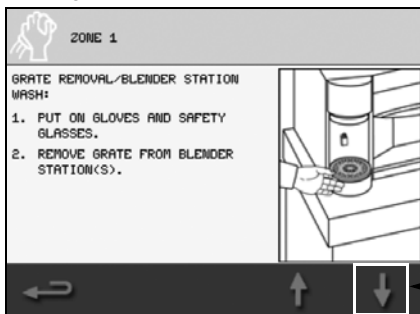

Blend Chamber Grate Removal

2. Spray all surfaces inside blender station with cleaning solution.
 - * Then scrub thoroughly with approved cleaning brush.
 - Press the down arrow to continue.
3. Thoroughly wipe down all surfaces of mixer station & repeat for the other side if applicable.
 - Press the down arrow to continue.

Dispensing Area Cleaning

1. Remove center grate from dispensing area.

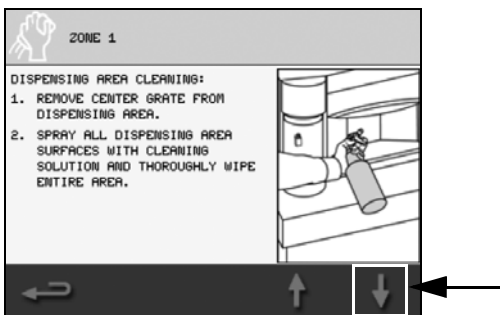

Dispense Area Screen

2. Spray all dispensing area surfaces with cleaning solution.
 - * Then use approved cleaning brush to thoroughly scrub area.
 - Press the down arrow to continue.
3. Thoroughly spray each individual dispense nozzle with cleaning solution and apply cleaner to each individual dispensing valve.
 - * Then use approved cleaning brush to carefully scrub area.
4. Thoroughly wipe all dispense valves and dispense area with a clean towel.
 - Press the down arrow to continue.

Mixer Door Removal

1. Slightly open mixer door.

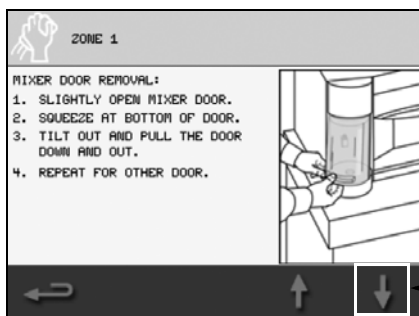

Mixer Door Removal Screen

2. Squeeze at bottom of door.
3. Tilt out and pull the door down and out.
4. Repeat for other door if applicable.
 - Press the down arrow to continue.

Blender Station Wash

1. Completely spray blender station with cleaning solution.

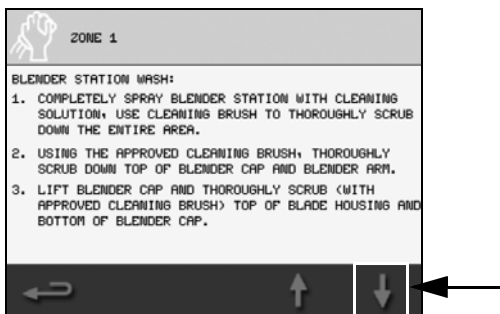

Blender Station Wash Screen

- * Use cleaning brush to thoroughly scrub down the entire area.
 - * Using the approved cleaning brush, thoroughly scrub down top of blender cap and blender arm.
2. Lift blender cap and thoroughly wipe down top of blade housing and bottom of blender cap.
 - * Scrub (with the approved cleaning brush) top of blade housing and bottom of blender cap.
 - Press the down arrow to continue.
 3. Thoroughly spray with sanitizer solution.
 - * Using the approved cleaning brush to scrub entire blender assembly.
 4. Repeat for other side if applicable.
 - Press the down arrow to continue.

Reinstall Grate(s)/Door(s)

1. Take all grate(s) and door(s) to sink to wash and sanitize.

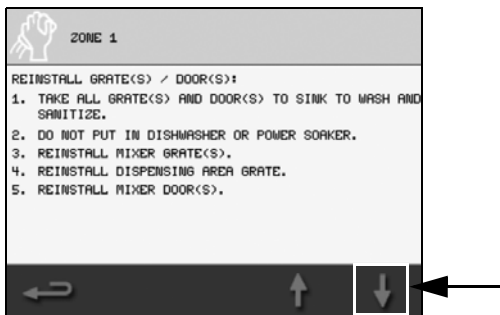

Grates & Doors Screen

Important

Never Use Steel Pads, Wire Brushes, Scrapers, or any Abrasive Cleaners / Scouring Pads!

2. Do not put in dishwasher or power soaker.
3. Reinstall mixer grate(s).
4. Reinstall dispensing area grate.
5. Reinstall mixer door(s).
 - Press the down arrow to continue.

Blender Wash

1. Place blue cleaning cup(s) with wash solution in blender station(s) and close the blender doors.
 - 0.425 oz/5 gal or Approved dish detergent solution)

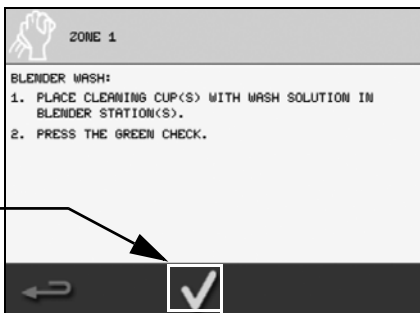

Blender Wash Screen

2. Press the green check to begin.

The blenders will lower into the wash solution and spin to clean. WASHING will display on the screen.

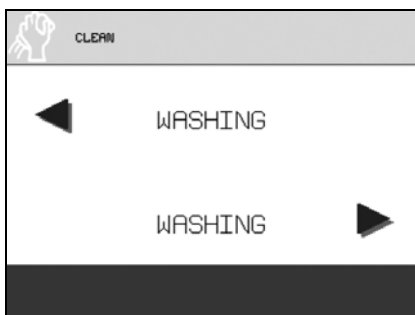

Washing Screen

Follow the on screen instruction, when prompted remove the blue cup(s) and pour wash solution down the drain.

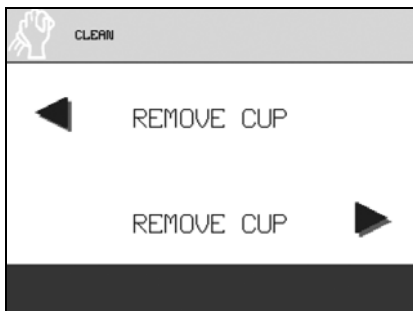

Remove Cup Screen

Close the blender door(s) and RINSING will display on the screen while the machine rinses the blenders.

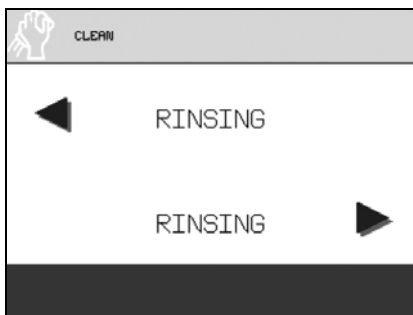

Rinse Screen

Finished will display on the screen then progress to the Blender Sanitizing screen.

Blender Sanitizing

1. Place red sanitizing cup(s) with sanitizing solution in blender station(s) and close the blender doors.
 - Use approved sanitizer solution that provides 100 ppm available chlorine.

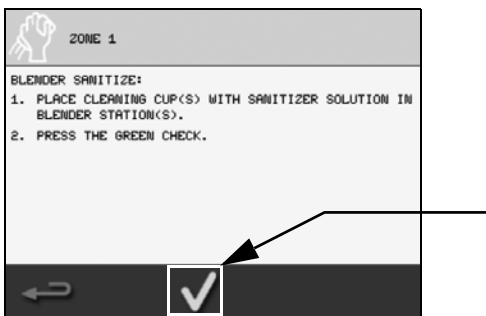

Blender Sanitizing Screen

2. Press the green check to begin.

The blenders will lower into the wash solution and spin to sanitize. SANITIZE will display on the screen.

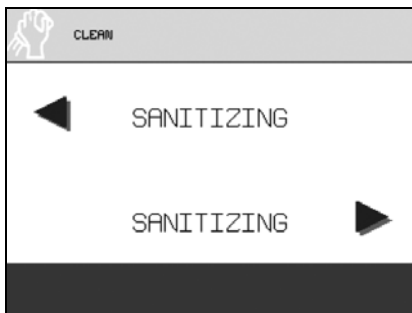

Sanitizing Screen

Follow the on screen instruction, when prompted remove the red cup(s) and pour sanitizing solution down the drain.

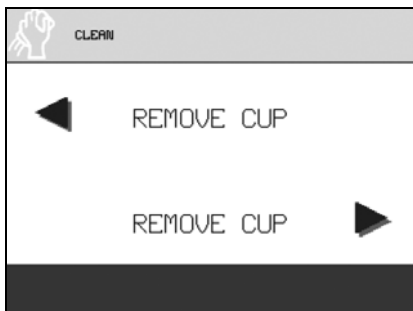

Remove Cup Screen

Close the blender door(s) and RINSING will display on the screen while the machine rinses the blenders.

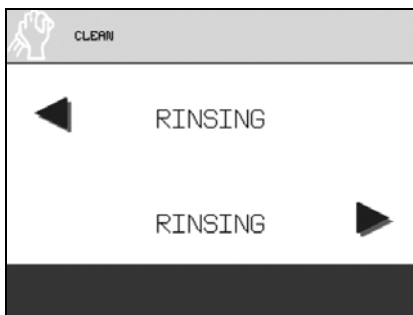

Rinse Screen

Finished will display on the screen then progress to the Blender Station Sanitizing screen.

Blender Station Sanitizing

1. Completely spray blender station with cleaning solution.
 - * Use cleaning brush to thoroughly scrub down the entire area.

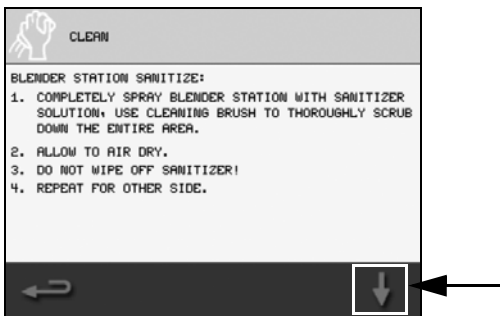

Blender Station Sanitizing Screen

2. Allow to air dry, Do not wipe off sanitizer!
3. Repeat for other side if applicable.
 - Press the down arrow to continue.

Dispensing Area Sanitizing

1. Thoroughly spray each individual dispense nozzle with sanitizer solution.

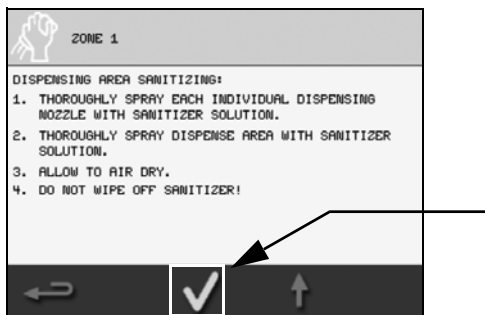

Dispense Area Sanitizing Screen

2. Thoroughly spray dispense area with sanitizer solution.
3. Allow to air dry, **Do not wipe off sanitizer!**
 - Press the green check to signify you have completed the Zone 2 Weekly Cleaning or continue on to Drain Cleaning if equipped with this option.

DRAIN CLEANING (OPTIONAL)

* Only for units with this feature. These steps will only display during the ZONE 2 Cleaning on units with this feature turned on in the loaded recipe file. If this feature is not active the interface will automatically proceed to “Weekly Cleaning Completed” on page 99

Prepare Unit for Drain Cleaning

1. Remove doors from blender station(s).

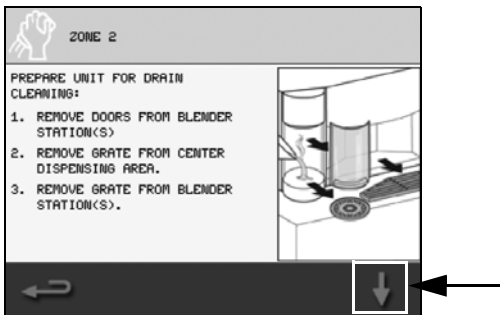

Drain Cleaning Screen 1

2. Remove grate from center dispensing area.
3. Remove grate from blender station(s).
 - Press the down arrow to continue.
4. Slowly pour 1 gal / 3.8 L of hot (120-130°F / 49-54°C) water into each drain.
 - Press the down arrow to continue.

Prepare Drain Cleaning Solution

1. On the top of the dispenser, open pressure relief knob by turning counter-clockwise.

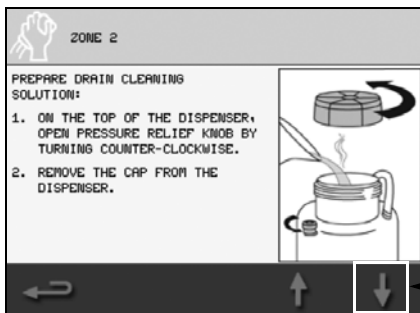

Prepare Cleaning Solution

2. Remove the cap from the dispenser.
 - Press the down arrow to continue.
3. Pour 1 gal / 3.8 L of hot (120-130°F / 49-54°C) water into the dispenser.
 - Press the down arrow to continue.
4. Quickly pour one packet of drain cleaner into dispenser.

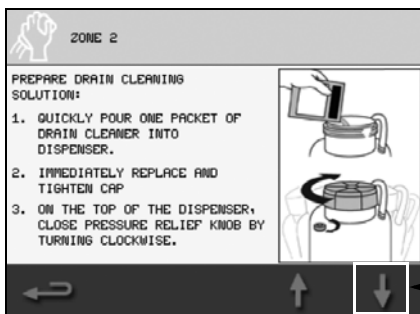

Mix Cleaning Solution

5. Immediately replace and tighten cap.
6. On the top of the dispenser, close pressure relief knob by turning clockwise.
 - Press the down arrow to continue.

7. Shake dispenser to dissolve cleaner.
 - Press the down arrow to continue.

Drain Cleaning

1. Carefully purge a small amount of solution from the dispenser into the sink.

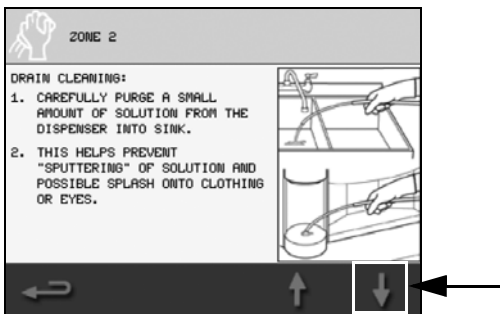

Purge Drain Cleaning Dispenser

2. This helps prevent “sputtering” of solution and possible splash onto clothing or eyes.
 - Press the down arrow to continue.
3. Carefully spray an equal amount of the solution into each drain.
 - Press the down arrow to continue.

Post Drain Cleaning

1. Open the pressure relief knob again by turning counter-clockwise.

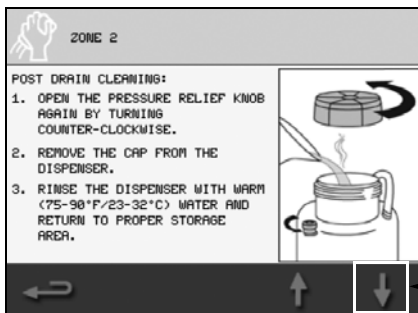

Post Drain Cleaning Screen

2. Remove cap from the dispenser.
3. Rinse the dispenser with warm (75-90°F/23-32°C) water and return to the proper storage area.
 - Press the down arrow to continue.

Reinstall Grate(s) / Door(s)

1. Wipe drain areas and work surface with sanitized towel to remove drain cleaner.

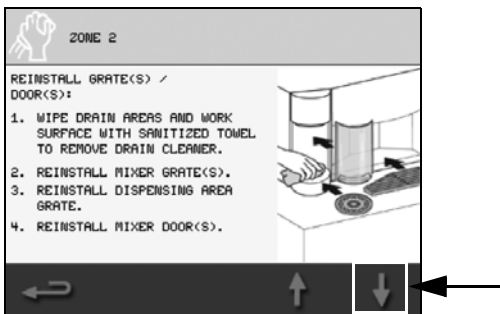

Grates & Doors Install Screen

2. Reinstall mixer grate(s).
3. Reinstall dispensing area grate.
4. Reinstall mixer door(s).
 - Press the down arrow to continue.

Important

Drain cleaner is most effective when left for four (4) hours, but the machine can be used as needed.

- Press the green check to continue.

Weekly Cleaning Completed

1. * Remove gloves & safety glasses.

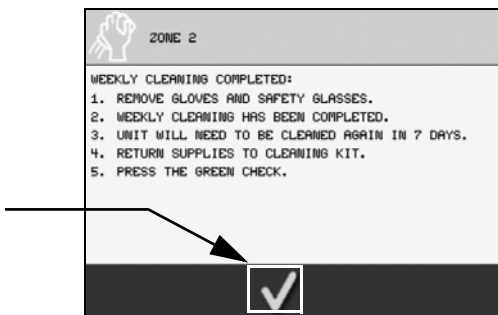

Completed Screen

2. Weekly cleaning has been completed.
3. Unit will need to be cleaned again in 7 days.
4. Return supplies to cleaning kit.
5. Press the green check to signify you have completed the Zone 2 Weekly Cleaning. The screen will return to the Main Menu Screen.

Monthly Cleaning - Zone 3

NOTE: All steps will be displayed on screen.

* These items are optional and may not be displayed on all EasyTouch screens during ZONE 3 Cleaning.

- Time to complete - 1 hour 45 minutes

1. Cycle touch screen to the Main Menu and select the Cleaning Icon.

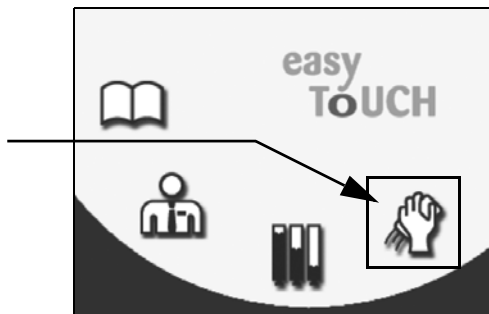

Main Menu Touch Screen

2. In the cleaning screen select the Zone 3 Icon.

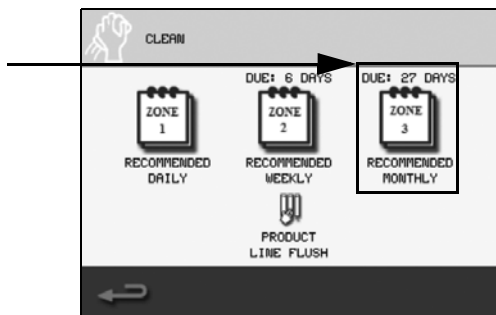





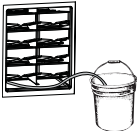

Cleaning Touch Screen

NOTE: Failure to complete the Zone 3 cleaning sequence in its entirety could affect drink quality and will not reset the monthly cleaning timer which will require the process to be repeated.

GATHER THE FOLLOWING SUPPLIES

Follow the on screen instructions and gather the following supplies;

<p>Cleaning Buckets - Set of 2</p>	
<p>Cleaning Hose</p>	
<p>Ice Removal Chute</p>	
<p>Splash Guard</p>	
<p>Clean towels (* Cloths)</p>	
<p>Sanitizing Solution (Approved sanitizer solution that provides 100 ppm available chlorine.)</p>	
<p>* Scoop, Cleaning Brush, Gloves & Safety Glasses</p>	
<p><i>* These items are optional and may not be displayed on all EasyTouch screens.</i></p>	

NOTE: If other cleaners are used, it is possible they will not clean or sanitize your machine to NSF standards.

- Press the down arrow to continue

ICE MAKER / BIN DESCALING, CLEANING & SANITIZING

Removal of Ice

Follow the on screen instructions;

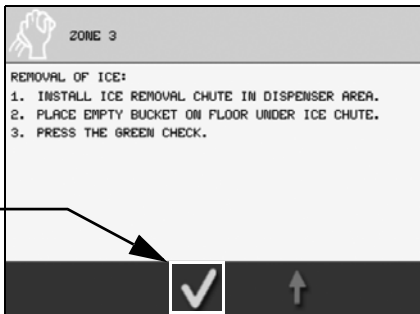

Ice Removal Screen

1. Install ice removal chute in dispenser area.
2. Place empty bucket on floor under ice chute.
3. Press the green check to begin dispensing ice.
 - The Ice Dispensing Timer Screen will display, the machine will empty of ice.



Ice Dispense Timer Screen

Ice Disposal

1. Dispose of ice in the bucket and set aside.

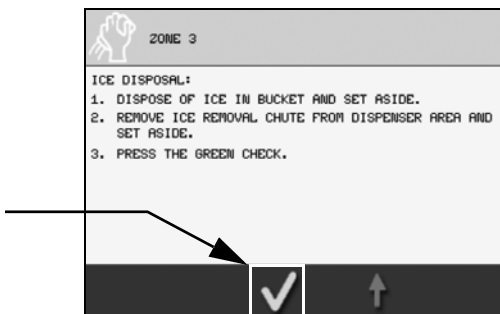

Ice Disposal Screen

2. Remove ice removal chute from the dispenser area and set aside.
3. Press the green check to continue.

Sanitizing Ice Maker Prep

1. Install splash guard in the dispense area.

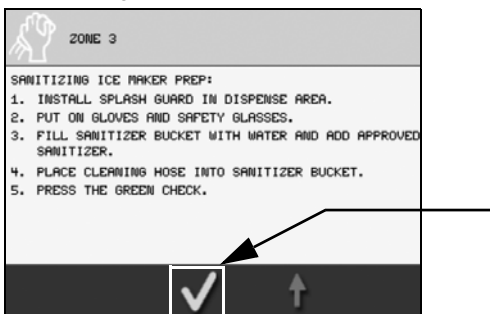

Sanitizing Prep Screen

- * Put on gloves and safety glasses.
2. Fill sanitizer bucket with water and add sanitizer. (Use approved sanitizer solution that provides 100 ppm available chlorine.)
 3. Place cleaning hose into the sanitizer bucket.
 4. Press the green check to begin sanitizing the ice machine.
- The Sanitize Ice Maker Timer Screen will display and count down during the sanitizing process.

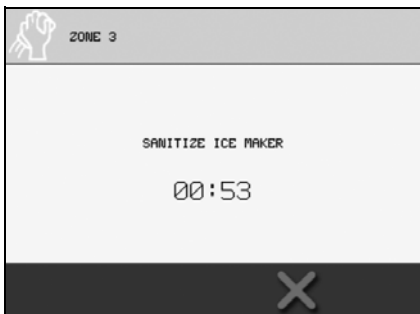

Sanitizing Timer Screen

- Discard Sanitizer & Ice Prep Screen will display once completed.

Discard Sanitizer & Ice Purge Prep

1. Discard remaining sanitizer from the bucket.

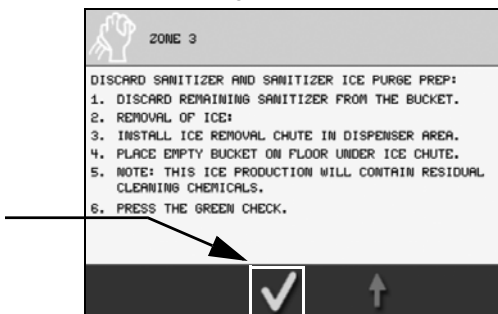

Discard Sanitizer Screen

2. Removal of Ice.
3. Install ice removal chute in dispenser area.
4. Place empty bucket on the floor under the ice chute.



Warning

This ice production will contain residual cleaning chemicals and must be discarded.

5. Press the green check to begin dispensing ice.
 - The Ice Dispensing Timer Screen will display, the machine will empty of ice.



Ice Dispense Timer Screen

Ice Disposal

1. Dispose of ice in the bucket and set aside.

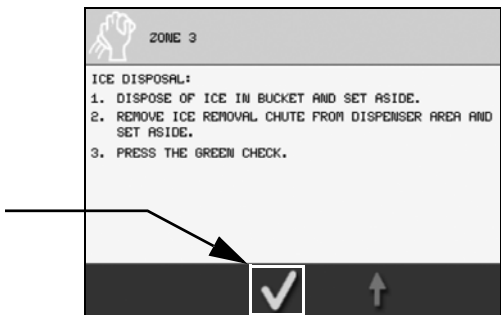

Ice Disposal Screen

2. Remove ice removal chute from the dispenser area and set aside.
3. Press the green check to continue.

Sanitizing Ice Bin & Water Nozzles Prep

1. Install splash guard in dispense area.

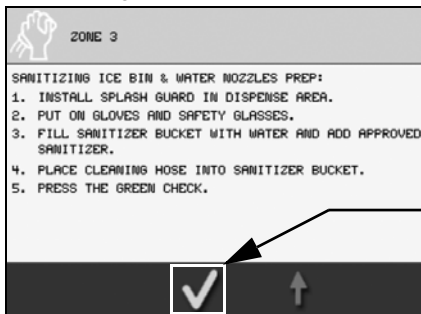

Bin & Nozzles Prep Screen

- * Put on gloves and safety glasses.
2. Fill sanitizer bucket with water and add sanitizer. (Use approved sanitizer solution that provides 100 ppm available chlorine.)
 3. Place cleaning hose into the sanitizer bucket.
 4. Press the green check to begin sanitizing the ice bin and water nozzles.
- The Sanitizing Timer Screen will display, and count down during the sanitizing process.

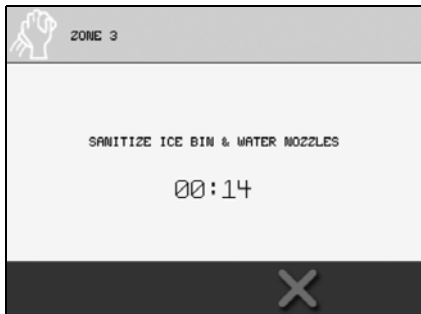

Sanitizing Timer Screen

Discard Sanitizer

1. Install cleaning hose into the bottom of the refrigerated cabinet.

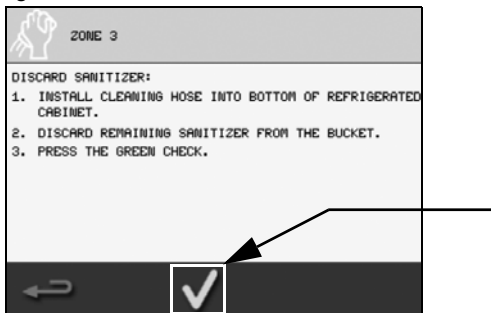

Discard Sanitizer Screen

2. Discard remaining sanitizer from the bucket.
3. Press green check to continue.

Rinsing Sanitizer Prep

1. Install splash guard in the dispense area.

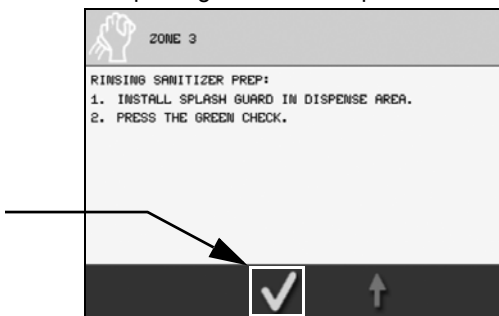

Plain Water Rinse

2. Press the green check to begin the plain water rinse cycle.
 - The Rinse Timer Screen will display, and count down during the rinsing process then automatically proceed to the Cleaning Solution Ice Production Screen.



Rinse Timer Screen

Ice Maker Cleaning Solution Ice

- Ice will then be produced using water from the unit's chilled water source to remove any remaining cleaning solution from the ice maker.

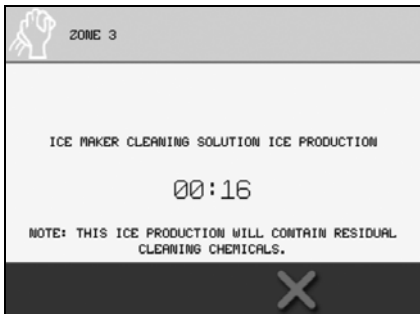

Ice Production Timer Screen



Warning

This ice production will contain residual cleaning chemicals and must be discarded.

Removal of Ice

1. Install ice removal chute in dispenser area.

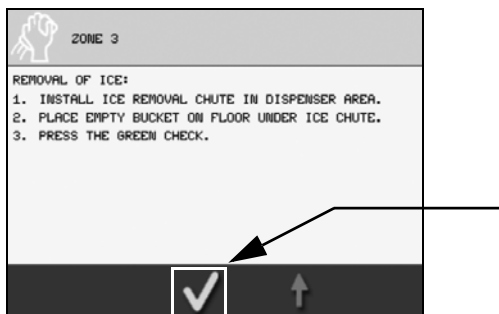

Ice Removal Screen

2. Place empty bucket on floor under ice chute.
3. Press the green check to begin dispensing ice.
 - The Ice Dispensing Timer Screen will display, the machine will empty of ice.

Ice Disposal

1. Dispose of ice in the bucket and set aside.

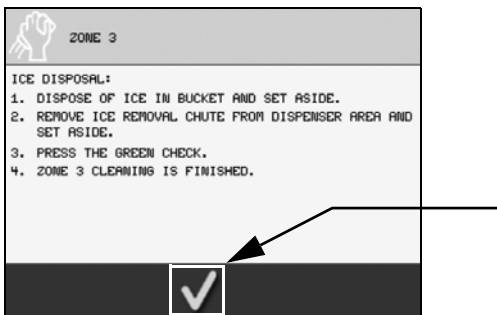

Ice Disposal Screen

2. Remove ice removal chute from the dispenser area and set aside.
3. Press the green check to signify you have completed the Zone 3 Monthly Cleaning. The screen will return to the Main Menu Screen.

Important

Ice storage has been depleted, low ice level may exist for 30 minutes!

OTHER MONTHLY TASKS

Air Filters

For units equipped with upper and/or lower air filters. Each month check the air filters to be sure they are clean and allow proper airflow.

Air Filter Locations

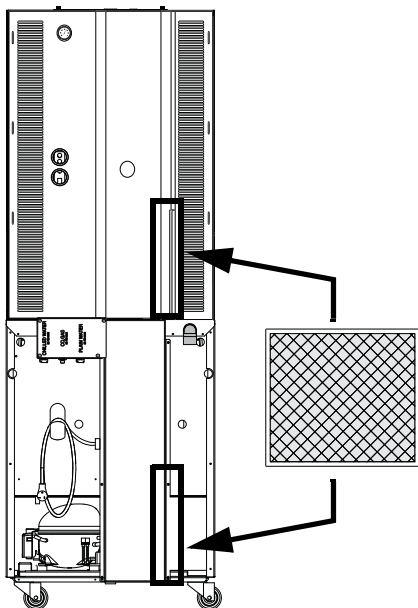

First access the rear of the unit. Slide them out one at a time and inspect them. If they are dirty or light will not pass through them when held up to light, take to a sink and wash with dish soap until clean. **DO NOT** put in a dishwasher.

Once clean, slide them back into place on the unit and move unit back into place.

Cleaning the Condenser Coil

In order to maintain proper refrigeration performance, the condenser fins must be cleaned of dust, dirt and grease regularly. It is recommended that this be done at least every three months. If conditions are such that the condenser is totally blocked in three months, the frequency of cleaning should be increased. Clean the condenser with a vacuum cleaner or stiff brush. If extremely dirty, a commercially available condenser cleaner may be required.

Failure to maintain a clean condenser coil can initially cause high temperatures and excessive run times. Continuous operation with a dirty or clogged condenser coil can result in compressor failure. Neglecting the condenser coil cleaning procedures will void any warranties associated with the compressor and cost to replace the compressor.

Caution

Never use a high-pressure water wash for this cleaning procedure as water can damage the electrical components located near or at the condenser coil.

Exterior Cleaning

Remove dust and dirt from the exterior surfaces with a mild household dish-washing detergent and warm water. wipe dry with a clean, soft cloth.

Use cleaners designed for use with stainless steel products.

Heavy stains should be removed with stainless steel wool. Never use plain steel wool or abrasive pads. they will scratch the panels.

Biannual Descaling- Zone 3

Descaling is recommended every six (6) months. More frequent descaling may be required in some existing water conditions. Follow carefully any instructions provided with the bottles of Ice Machine Descaling or sanitizing solution.



Warning

Always wear liquid-proof gloves to prevent the Descaling and sanitizing solutions from coming into contact with skin.

NOTE: All steps will be displayed on screen. * These items are optional and may not be displayed on all EasyTouch screens during ZONE 3 Cleaning.

- Time to complete - 2 hour

Descaling must first be turned on in the Manager Menu Service Screen before it can be performed as part of Zone 3 cleaning and will need to be turned off once completed.

Important

Only a trained manager or authorized technician should access the service screens. If changes to these settings are made incorrectly they can cause the unit to malfunction or not work at all.

TURN ON DESCALING

1. Cycle touch screen to the Main Menu and select the Managers Menu Icon.

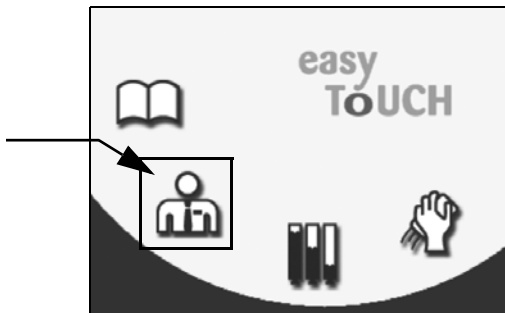

Main Menu Touch Screen

2. Enter the password ("A" is the default) using the QWERTY keyboard.

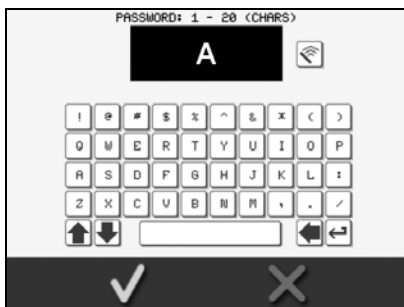

Managers Password Screen

3. Press the Down Arrow to advance to the next screen.



Manager Screen 1

4. Select the Service Icon.

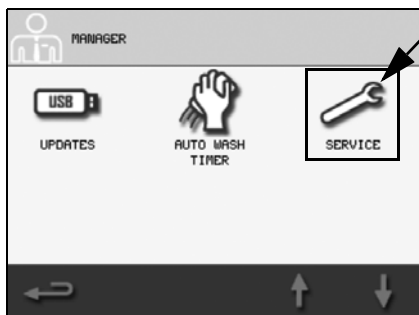

Manager Screen 2

5. Enter the password (“A” is the default) using the QWERTY keyboard.

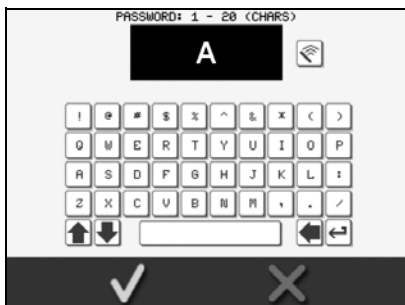

Service Password Screen

6. Select the Cleaning Options Button.

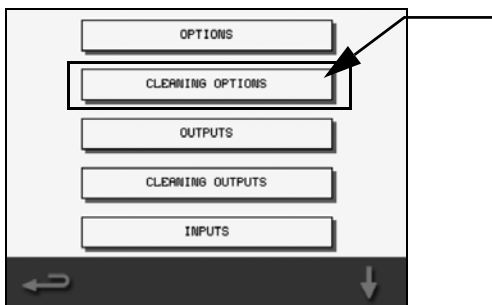

Service Screen 1

7. Touch the Zone 3 Descaling check box, the box should turn green with a check mark in it.

Descaling is now turned on during Zone 3 Cleaning.



Cleaning Options

8. Exit back out to the Main Menu using the Back Arrow multiple times, press SAVE when prompted, and then select the Cleaning Icon.

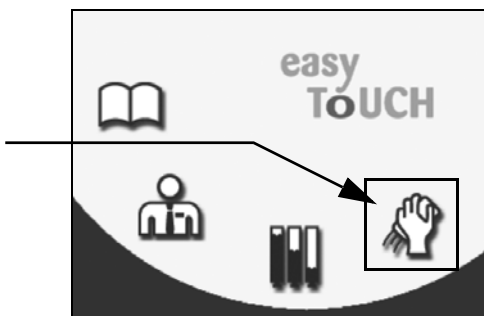

Main Menu Touch Screen

9. In the cleaning screen select the Zone 3 Icon.

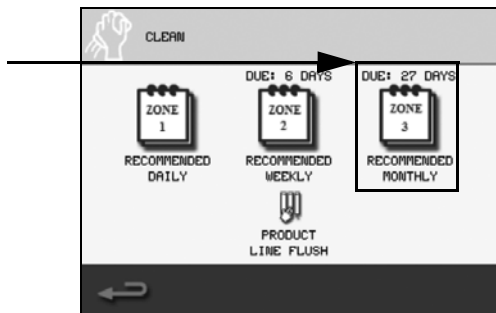







Cleaning Touch Screen

NOTE: Failure to complete the Zone 3 cleaning sequence in it's entirety could affect drink quality and will not reset the monthly cleaning timer which will require the process to be repeated.

GATHER THE FOLLOWING SUPPLIES

Follow the on screen instructions and gather the following supplies;

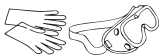
Cleaning Buckets - Set of 2	
Cleaning Hose	
Ice Removal Chute	
Splash Guard	
Clean towels (* Cloths)	
Descaler Solution (Use Approved Ice Machine Descaling Solution)	
Sanitizing Solution (Approved sanitizer solution that provides 100 ppm available chlorine.)	
* Scoop, Cleaning Brush, Gloves & Safety Glasses	
<i>* These items are optional and may not be displayed on all EasyTouch screens.</i>	

NOTE: If other cleaners are used, it is possible they will not clean or sanitize your machine to NSF standards.

- Press the down arrow to continue

ICE MAKER / BIN DESCALING, CLEANING & SANITIZING

Removal of Ice

Follow the on screen instructions;

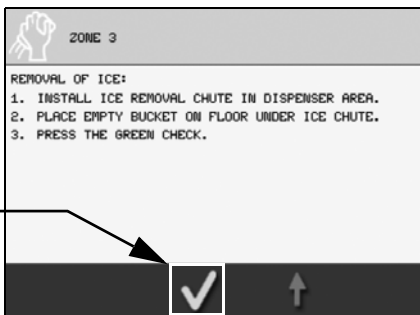

Ice Removal Screen

1. Install ice removal chute in dispenser area.
2. Place empty bucket on floor under ice chute.
3. Press the green check to begin dispensing ice.
 - The Ice Dispensing Timer Screen will display, the machine will empty of ice.



Ice Dispense Timer Screen

Ice Disposal

1. Dispose of ice in the bucket and set aside.

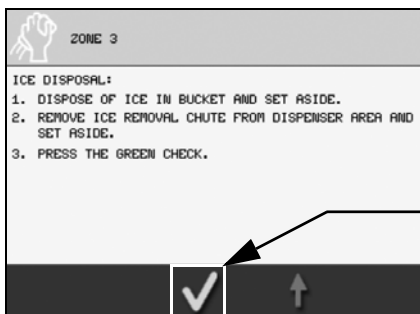

Ice Disposal Screen

2. Remove ice removal chute from the dispenser area and set aside.
3. Press the green check to continue.

Descaling Ice & Water System Prep

Important

These steps will only display if descaling has been turned on in the Managers Menu. If this feature is not active the interface will automatically proceed to "Sanitizing Ice Maker Prep" on page 104.

1. Install splash guard in the dispense area.

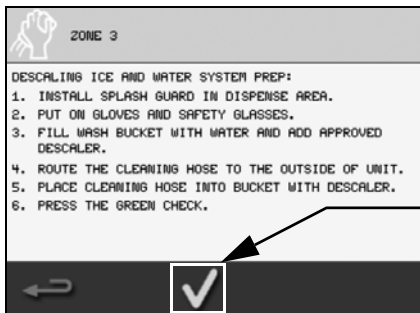

Descaling Prep Screen

- * Put on gloves and safety glasses.

2. Fill wash bucket with warm water and add descaler.
3. Route cleaning hose to the outside of unit.
4. Place cleaning hose into bucket with descaler solution.
5. Press the green check to begin descaling the ice machine.
 - The Descaling Ice Maker Timer Screen will display and count down during the descaling process.

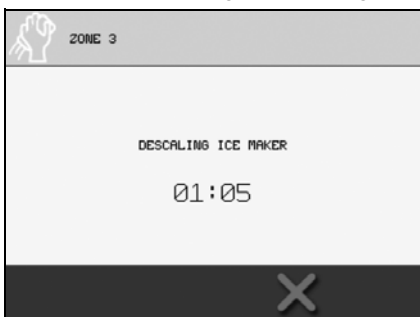

Descaling Timer Screen

- Continue Descaling Screen will display once completed.

Continue Descaling

1. Discard remaining descaler from the bucket.

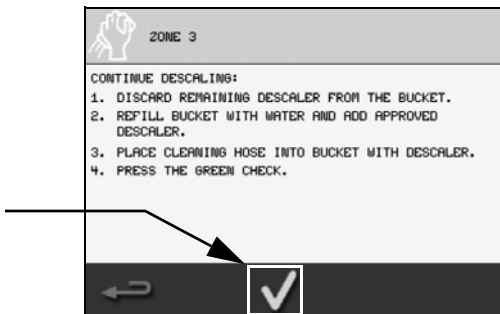

Continue Descaling Screen

2. Refill bucket with water and add approved descaler.
3. Place cleaning hose back into the descaler bucket.

4. Press the green check to descale the ice bin and water nozzles.

- The Descaling Bin & Nozzles Timer Screen will display and count down during the descaling process.

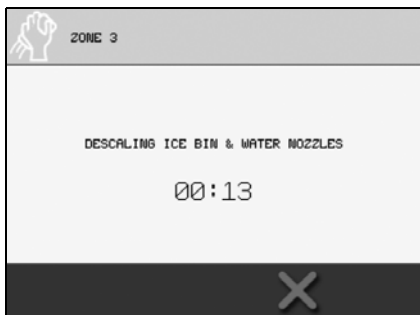

Descaling Timer Screen

- Discard Descaler Screen will display once completed.

Discard Descaler

1. Discard remaining descaler from the bucket.

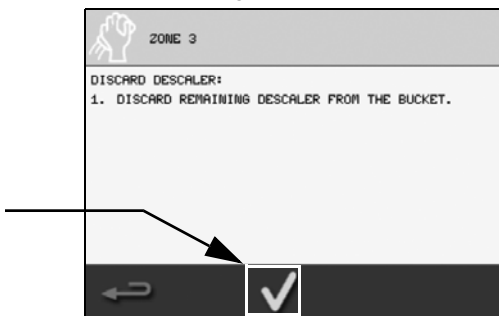

Discard Descaler Screen

- Press the green check to continue.

Sanitizing Ice Maker Prep

1. Install splash guard in the dispense area.

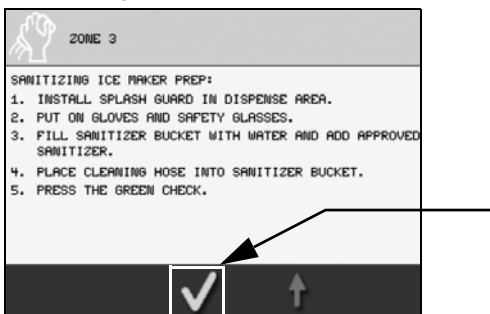

Sanitizing Prep Screen

- * Put on gloves and safety glasses.
2. Fill sanitizer bucket with water and add sanitizer. (Use approved sanitizer solution that provides 100 ppm available chlorine.) Place cleaning hose into the sanitizer bucket.
 3. Press the green check to begin sanitizing the ice machine.
 - The Sanitize Ice Maker Timer Screen will display and count down during the sanitizing process.

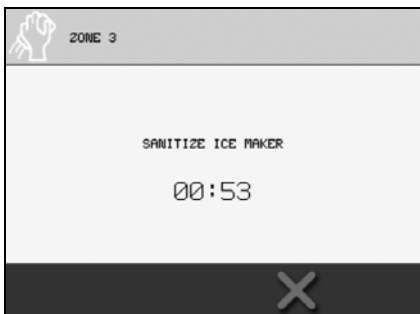

Sanitizing Timer Screen

- Discard Sanitizer & Ice Prep Screen will display once completed.

Discard Sanitizer & Ice Purge Prep

1. Discard remaining sanitizer from the bucket.

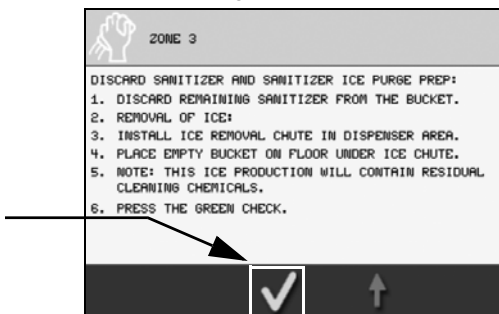

Discard Sanitizer Screen

2. Removal of Ice.
3. Install ice removal chute in dispenser area.
4. Place empty bucket on the floor under the ice chute.



Warning

This ice production will contain residual cleaning chemicals and must be discarded.

5. Press the green check to begin dispensing ice.
 - The Ice Dispensing Timer Screen will display, the machine will empty of ice.



Ice Dispense Timer Screen

Ice Disposal

1. Dispose of ice in the bucket and set aside.

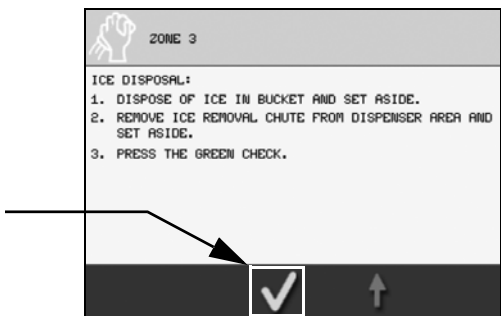

Ice Disposal Screen

2. Remove ice removal chute from the dispenser area and set aside.
3. Press the green check to continue.

Sanitizing Ice Bin & Water Nozzles Prep

1. Install splash guard in dispense area.

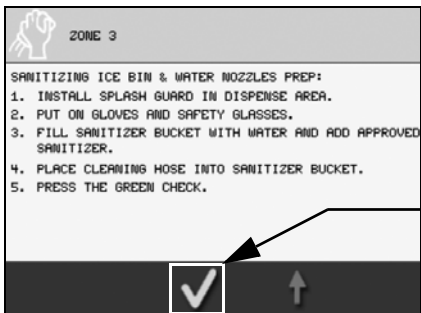

Bin & Nozzles Prep Screen

- * Put on gloves and safety glasses.
2. Fill sanitizer bucket with water and add sanitizer. (Use approved sanitizer solution that provides 100 ppm available chlorine.)
 3. Place cleaning hose into the sanitizer bucket.

4. Press the green check to begin sanitizing the ice bin and water nozzles.
 - The Sanitizing Timer Screen will display, and count down during the sanitizing process.

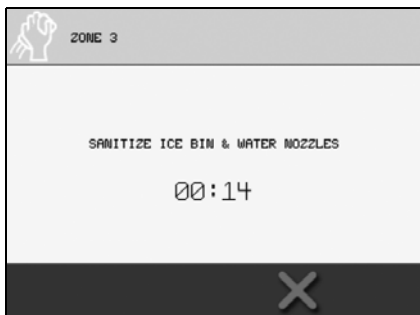

Sanitizing Timer Screen

Discard Sanitizer

1. Install cleaning hose into the bottom of the refrigerated cabinet.

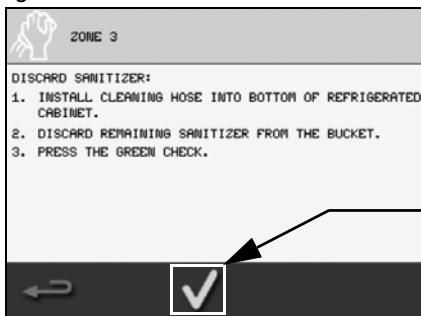

Discard Sanitizer Screen

2. Discard remaining sanitizer from the bucket.
3. Press green check to continue.

Rinsing Sanitizer Prep

1. Install splash guard in the dispense area.

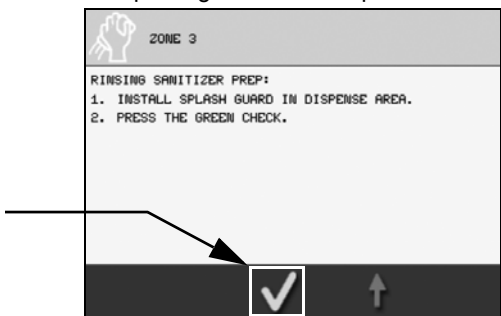

Plain Water Rinse

2. Press the green check to begin the plain water rinse cycle.
 - The Rinse Timer Screen will display, and count down during the rinsing process then automatically proceed to the Cleaning Solution Ice Production Screen.



Rinse Timer Screen

Ice Maker Cleaning Solution Ice

- Ice will then be produced using water from the unit's chilled water source to remove any remaining cleaning solution from the ice maker.

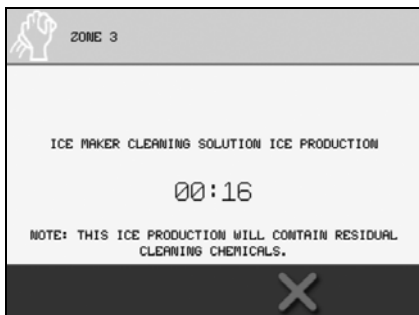

Ice Production Timer Screen



Warning

This ice production will contain residual cleaning chemicals and must be discarded.

Removal of Ice

1. Install ice removal chute in dispenser area.

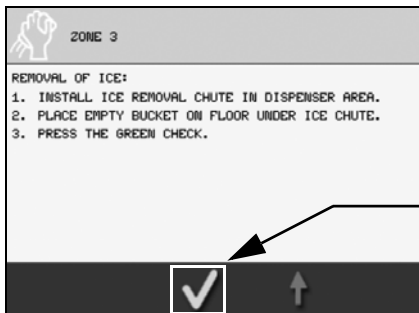

Ice Removal Screen

2. Place empty bucket on floor under ice chute.
3. Press the green check to begin dispensing ice.
 - The Ice Dispensing Timer Screen will display, the machine will empty of ice.

Ice Disposal

1. Dispose of ice in the bucket and set aside.

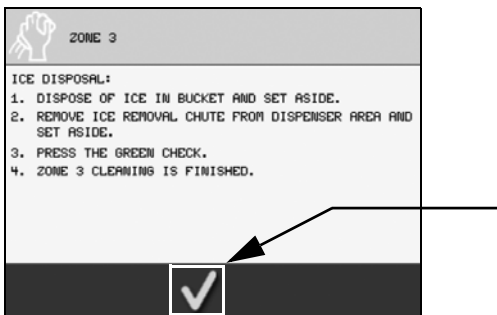

Ice Disposal Screen

2. Remove ice removal chute from the dispenser area and set aside.
3. Press the green check to signify you have completed the Zone 3 Monthly Cleaning. The screen will return to the Main Menu Screen.

Important

Ice storage has been depleted, low ice level may exist for 30 minutes!

TURN OFF DESCALING

4. From the Main Menu select the Managers Menu Icon.

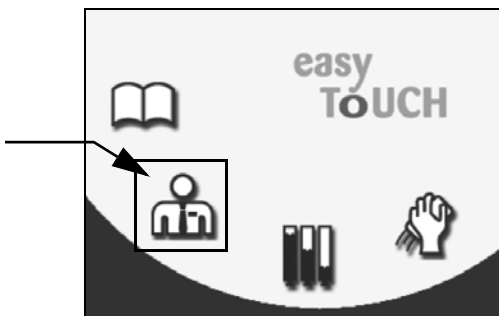

Main Menu Touch Screen

5. Enter the password ("A" is the default) using the QWERTY keyboard.

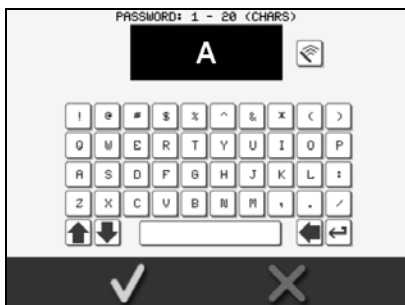

Managers Password Screen

6. Press the Down Arrow to advance to the next screen.

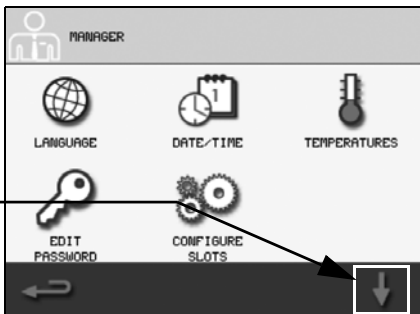

Manager Screen 1

7. Select the Service Icon.

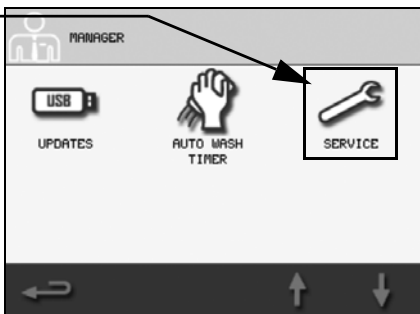

Manager Screen 2

8. Enter the password (“A” is the default) using the QWERTY keyboard.

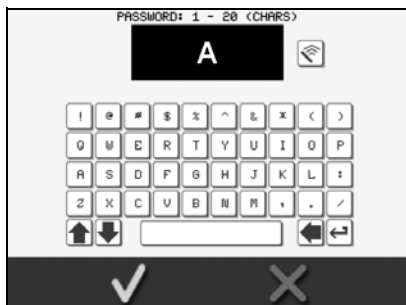

Managers Password Screen

9. Select the Cleaning Options Button.

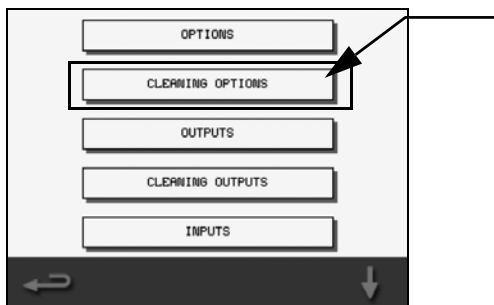

Service Screen 1

10. Touch the Zone 3 Descaling check box, the box should turn red with a “x” in it. Descaling is now turned off during Zone 3 Cleaning.

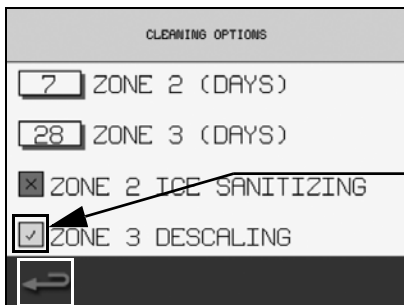

Cleaning Options

11. Exit back out to the Main Menu using the Back Arrow multiple times, press save when prompted.

Important

Ice storage has been depleted, low ice level may exist for 30 minutes!

Product Line Flush

NOTE: The following procedures are the basic product line flushing instructions, on screen instructions can vary depending on the recipe that was created with the MenuConnect program or options chosen in the Managers Menu. The Product Line Flush procedure allows a user to choose which lines to flush instead of being forced to flush every product line in the unit.

** These items are optional and may not be displayed on all EasyTouch screens during the Product Line Flush procedure.*

1. Cycle touch screen to the Main Menu and select the Cleaning Icon.

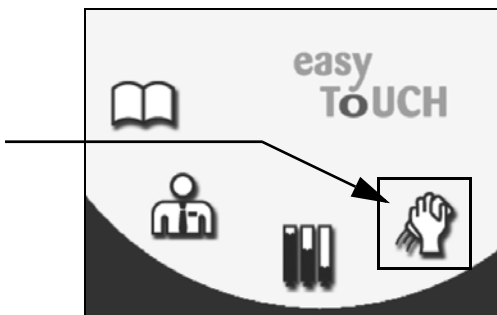

Main Menu Touch Screen

2. In the cleaning screen select the Product Line Flush Icon.

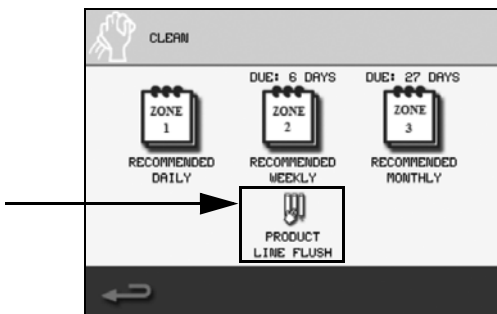







Cleaning Touch Screen

NOTE: Performing the product line flush through this interface procedure will not reset the Zone 2 cleaning countdown timer, Zone 2 cleaning will need to be performed in its entirety in order to reset the counter.

GATHER THE FOLLOWING SUPPLIES

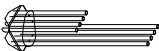
Follow the on screen instructions and gather the following supplies;

<p>Clean towels (* Cloths)</p>	
<p>Spray Cleaner & Detergent Solution (Approved dish detergent solution)</p>	
<p>Spray Sanitizer & Solution (Approved sanitizer solution that provides 100 ppm available chlorine.)</p>	
<p>Set of Three (3) Cleaning Buckets (Wash, Rinse & Sanitize Solutions)</p>	
<p>Splash Shield</p>	
<p>Cleaning Manifold</p>	
<p>* Scoop, Cleaning Brush, Gloves & Safety Glasses</p>	
<p><i>* These items are optional and may not be displayed on all EasyTouch screens.</i></p>	

NOTE: If other cleaners are used, it is possible they will not clean or sanitize your machine to NSF standards.

- Press the down arrow to continue.

Prepare Cleaning Solutions

1. Follow the on screen instructions;

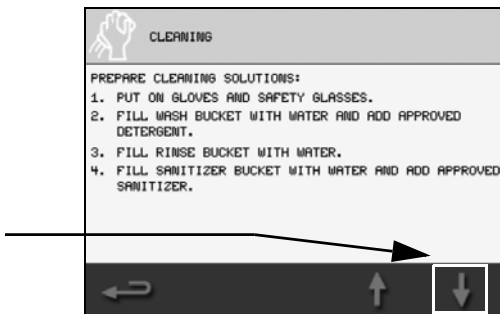

Prepare Solutions Screen

- * Put on gloves & safety glasses.
2. Fill wash bucket with water and add detergent. (Use approved dish detergent solution.)
 3. Fill rinse bucket with water.
 4. Fill sanitizer bucket with water and add approved sanitizer. (Use approved sanitizer solution that provides 100 ppm available chlorine.)
- Press the down arrow to continue.

Washing Instructions

1. Remove grate from center dispensing area.

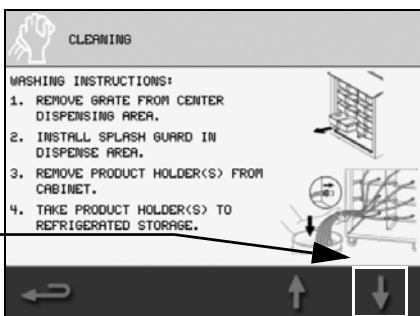

Washing Instructions Screen

2. Install splash guard in dispense area.
3. Remove product holders from cabinet.
 - Press the down arrow to continue
4. Take product holders to refrigerated storage.
5. Spray and wipe each BIB connector and area with cleaner.
6. Spray and wipe each BIB connector and area with sanitizer.
7. Connect a cleaning hose to each product nozzle.
 - Press the down arrow to continue
8. Place cleaning manifold in wash bucket.
9. Press the green check to go to the next screen.

Select Slots to Flush

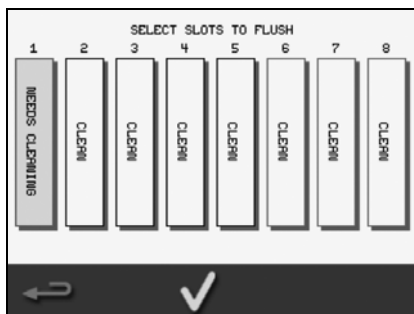

Flush Slot Selection Screen

- Touch each slot that needs to be flushed, select any or all slots 1 - 8. Selected slots will become highlighted in green and say NEEDS CLEANING.
- Slots that are not selected will say CLEAN.
- Slots outlined in red do not currently have a product assigned but may be selected to flush.
- The green check will appear once a slot has been selected. Once all the slots to be flushed have been selected, press the green check to continue.

This will automatically send the wash solution through each line (slot) that was selected, displaying the progress on the screen, 30 seconds per slot.

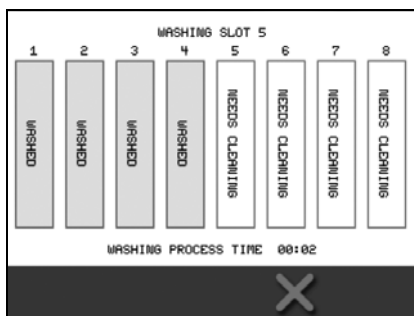

Product Line Washing Screen

When washing has completed the Rinsing Instructions Screen will appear automatically.

Rinsing Instructions

1. Remove cleaning manifold from wash bucket.

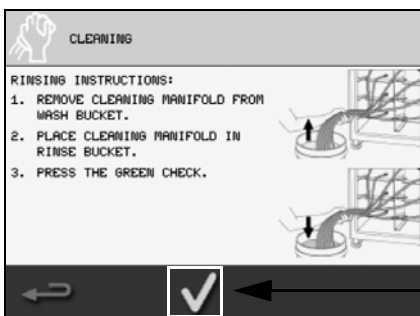

Rinsing Instructions Screen

2. Place cleaning manifold in rinse bucket.
3. Press the green check to begin rinsing the lines.

This will automatically send the rinse solution through each line (slot) that was selected, displaying the progress on the screen, 30 seconds per slot.

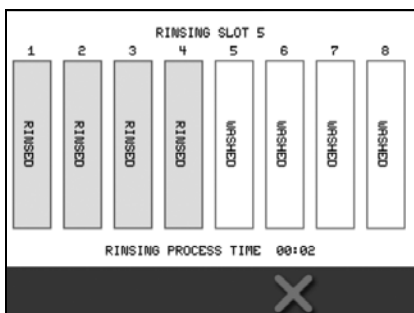

Product Line Rinsing Screen

When rinsing has completed the Sanitization Instructions Screen will appear automatically.

Sanitization Instructions

1. Remove cleaning manifold from rinse bucket.

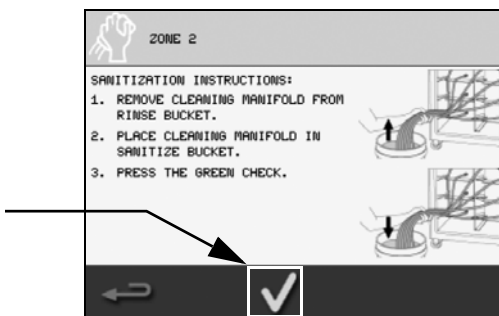

Sanitizing Instructions Screen

2. Place cleaning manifold in the sanitize bucket.
3. Press the green check begin sanitizing the lines.

This will automatically send the sanitizing solution through each line (slot) that was selected, displaying the progress on the screen, 30 seconds per slot.

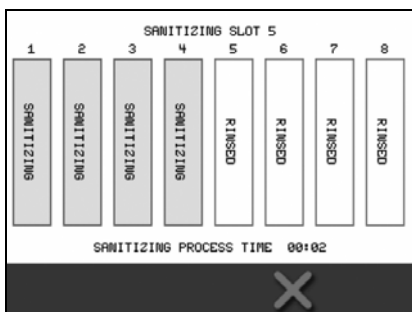

Product Line Sanitizing Screen

When sanitizing has completed the Purging Instructions Screen will appear automatically.

Purging Instructions

1. Disconnect the cleaning hoses from the product nozzles.

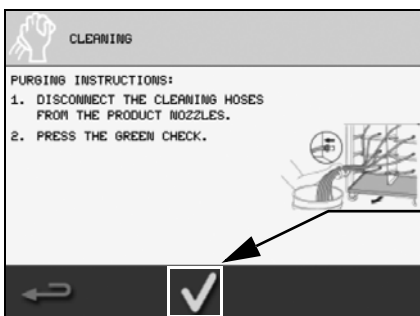

Purging Instructions Screen

2. Press the green check begin purging the lines.

Air is pushed through each line (slot) that was selected, blowing out any remaining liquid, displaying the progress on the screen, 30 seconds per slot.

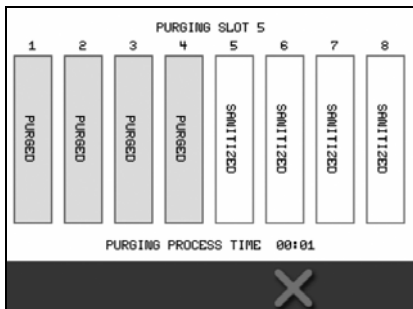

Product Line Purging Screen

When purging has completed the Reinstall Inventory Screen will appear automatically.

Reinstall Inventory

1. Retrieve product holders from refrigerated storage.

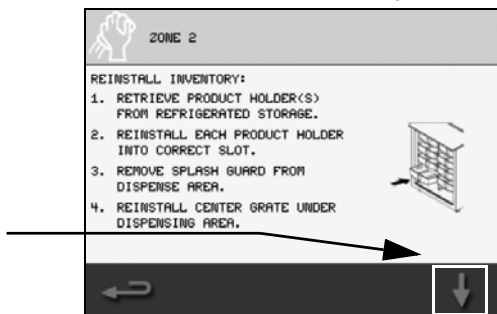

Reinstall Inventory Screen

2. Reinstall each product holder into correct slot.
3. Remove splash guard from dispense area.
4. Reinstall center grate under dispensing area.
 - Press the down arrow to continue.
5. Place a large cup under dispensing nozzles
6. Press the green check to continue to the next screen.

Select Slots to Prime

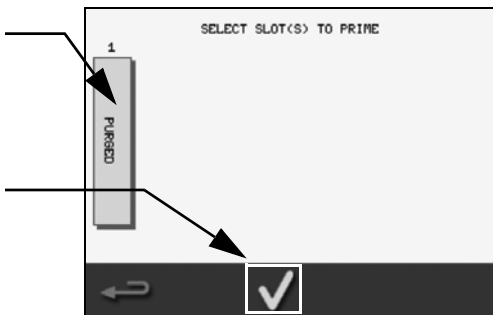

Prime Slot Selection Screen

- Touch each slot that needs to be primed, only the slots that were selected at the beginning of this sequence and flushed will be available as a choice.

NOTE: If a line that does not have product assigned was cleaned it will not need purged.

- Selected slots will become highlighted in green.
- The green check will appear once a slot has been selected. Once all the slots to be primed have been selected, press the green check to continue.

This will automatically prime each line that was selected with product. The screen will read Priming Slot X. Each slot will change from Purged to Primed.

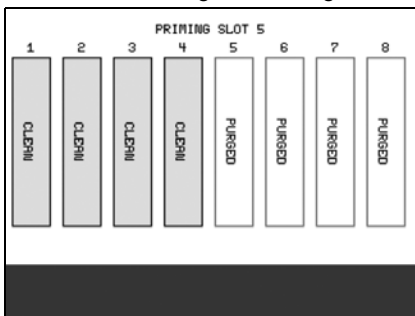

Priming Screen

When priming has completed the Prime Completion Screen will appear automatically.

Auto Prime Complete

1. Remove and dispose of large cup with primed product.

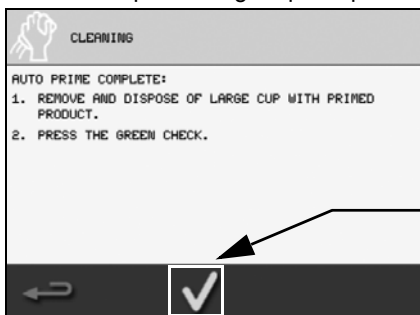

Prime Completed Screen

2. Press the green check to continue to the Dispensing Area Cleaning screen.

Dispensing Area Cleaning

1. Remove center grate from dispensing area.

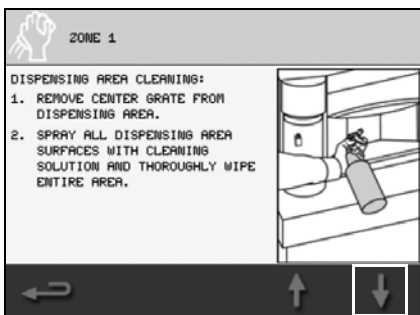

Dispense Area Screen

2. Spray all dispensing area surfaces with cleaning solution.
 - * Then use approved cleaning brush to thoroughly scrub area.
 - Press the down arrow to continue.
3. Thoroughly spray each individual dispense nozzle with cleaning solution and apply cleaner to each individual dispensing valve.
 - * Then use approved cleaning brush to carefully scrub area.
4. Thoroughly wipe all dispense valves and dispense area with a clean towel.
 - Press the down arrow to continue.

Dispensing Area Sanitizing

1. Thoroughly spray each individual dispense nozzle with sanitizer solution.

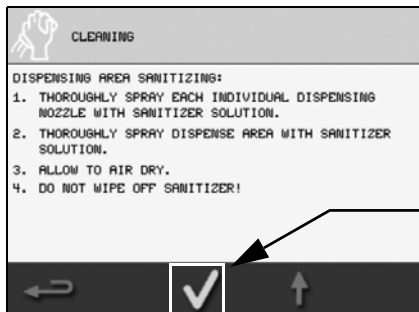

Dispense Area Sanitizing Screen

2. Thoroughly spray dispense area with sanitizer solution.
3. Allow to air dry, **Do not wipe off sanitizer!**
 - Press the green check to continue.

Product Line Flush Completed

1. Take dispense area grate to sink to wash and sanitize.

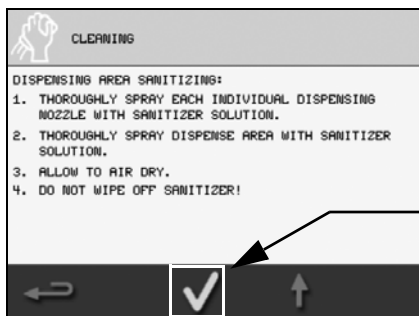

Dispense Area Sanitizing Screen

2. Reinstall dispense area grate.
3. * Remove gloves and safety glasses.
4. Return supplies to cleaning kit.
5. Press the green check to complete Product Line Flush. The screen will return to the Main Menu.

Manual Ice Machine Cleaning

Descaling is recommended every six (6) months and can be done as apart of the Zone 3 Cleaning Clean In Place. If a more thorough break down of the ice machine components is required for cleaning follow the steps in this section. More frequent descaling may be required in some existing water conditions. Quarterly sanitizing is recommended (every three (3) months). To be performed by a qualified service technician.

To prevent injury to individuals and damage to the ice maker, do not use ammonia type cleaners.

Follow carefully any instructions provided with the bottles of Ice Machine Descaling or sanitizing solution.

Warning

Always wear liquid-proof gloves to prevent the descaling and sanitizing solutions from coming into contact with skin.

FOR MB-8-1PP

1. Disconnect power, remove left side and rear panels and set the power and compressor rocker switches to the off position.
2. Remove all ice from the bin/dispenser.
3. Turn off the ice making water supply.
4. Drain water from evaporator and reservoir through the evaporator/reservoir drain line and reinsert hose into hose clip.

Descaling

To be done every six (6) months, skip to “Sanitizing” on page 152 if just sanitizing the ice machine.

1. Use an approved descaling solution ratio noted below;

Amount of Luke Warm Water	Amount of Manitowoc Metal-safe Ice Machine Cleaner (PN: 000000084)
1 gallon (4 Liters)	5 ounces (150 ml)

2. Remove top cover from the water reservoir, block up reservoir float and fill the evaporator and reservoir with cleaning solution. Remainder of solution will be used for hand cleaning.
3. Verify the compressor rocker switch is in the OFF position, then reconnect power and run the gear motor for 15 minutes. Perform the following procedures during the 15 minute period:
 - Remove ice compression nozzle from evaporator and soak in cleaning solution.
 - Descale drain pan by gently flexing, then remove any scale residue.
 - Inspect water feed and drain lines and clean as needed.
 - Connect ice transport tube direct to evaporator and secure with hose clamp.
4. Disconnect power, then drain the cleaner/water from the evaporator and reservoir through the evaporator/reservoir drain line - Using a pitcher, fill and drain the evaporator/reservoir 4 times and reinsert the hose into the hose clip.
5. Proceed to “Sanitizing” on page 152.

Sanitizing

To be done every three (3) months.

1. Use an approved sanitizing solution ratio noted below;

Amount of Luke Warm Water	Amount of Sanitizer
1 gallon (4 Liters)	Approved sanitizer solution that provides 100 ppm available chlorine

2. Fill reservoir and evaporator with sanitizer/water solution.
3. Verify the compressor rocker switch is in the OFF position, then reconnect power and run the gear motor for 10 minutes.
4. During the 10 minute period rinse cleaner from compression nozzle with potable water and then soak in sanitizer/water solution.
5. Move the compressor rocker switch to the ON position. The ice machine will make ice with the sanitizer/water solution and deposit the ice in the bin/dispenser. Make ice for 20 minutes - add sanitizer/water solution as the water level in the reservoir drops.

NOTE: Do not allow the sanitizer/water level to drop below the sensing probes. The ice machine will start a 20 minute delay period if the sensing probes lose contact with the water for more than 10 seconds. If this happens refilling the reservoir, then disconnecting and reconnecting power will restart the ice machine.

6. Move the compressor rocker switch to the OFF position and disconnect power.
7. Drain the evaporator/reservoir and reinsert the drain hose into the hose clip.
8. Reinstall the ice compression nozzle and reservoir cover.
9. Remove blocking from under reservoir float and reinstall reservoir cover.

10. Turn on the ice making water supply, reconnect power and move the compressor rocker switch to ON.
11. Allow the ice machine to run for 20 minutes, then place the compressor rocker switch in the OFF position, disconnect power and discard all ice produced.



Warning

This ice production will contain residual cleaning chemicals and must be discarded.

12. Replace all cleaned parts in their correct positions:
13. Reinstall all removed panels.
14. Proceed to “Bin / Dispenser Descale, Clean, & Sanitize” on page 154.

BIN / DISPENSER DESCALE, CLEAN, & SANITIZE

Disassembly of the bin and dispenser parts is not required unless heavy accumulations of scale have been found. For full disassembly instructions proceed to “Bin / Dispenser Disassembly Descal, Clean, & Sanitize” on page 156.

1. Disconnect power to the unit to prevent injury.

Warning

To prevent injury disconnect main supply power to the dispenser (when used) before cleaning or sanitizing the bin area and dispenser parts.

2. Remove the unit top by removing four thumbscrews.

Descaling

To be done every six (6) months, skip to “Sanitizing” on page 155 if just sanitizing the Bin/Dispenser.

1. Use an approved descaling solution ratio noted below;

NOTE: For safety and maximum effectiveness, use the solution immediately after dilution.

Amount of Luke Warm Water	Amount of Manitowoc Metal-safe Ice Machine Cleaner (PN: 000000084)
1 gallon (4 Liters)	5 ounces (150 ml)

2. Rinse down bin and components with descale solution.
3. Rinse parts with clear water after cleaning.

Sanitizing

1. Use an approved descaling solution ratio noted below;

Amount of Luke Warm Water	Amount of Sanitizer
1 gallon (4 Liters)	Approved sanitizer solution that provides 100 ppm available chlorine

2. Spray all interior bin/dispenser surfaces with sanitizer and **DO NOT RINSE SANITIZED AREAS.**
3. Place the power rocker switch in the on position, reinstall all removed panels, and restore power to the unit.

BIN / DISPENSER DISASSEMBLY DESCALE, CLEAN, & SANITIZE

1. Disconnect power to the unit to prevent injury.

Warning

To prevent injury disconnect main supply power to the dispenser (when used) before cleaning or sanitizing the bin area and dispenser parts.

2. Remove the unit top by removing four thumbscrews.
3. Remove ice chute cover.
4. Remove ice dispense motor assembly by removing four thumbscrews.
5. Remove ice chute by removing two thumbscrews. There is a gasket between the ice chute and ice extruding head, remove it.
6. Remove ice bin cover.
7. Remove all ice manually. Be cautious of the washer in between the ice agitator and the bottom of the ice bin.

8. Use an approved descaling solution ratio noted below.

NOTE: For safety and maximum effectiveness, use the solution immediately after dilution. Descaling to be done every six (6) months, skip descaling steps if just performing sanitization.

Amount of Luke Warm Water	Amount of Manitowoc Metal-safe Ice Machine Cleaner (PN: 000000084)
1 gallon (4 Liters)	5 ounces (150 ml)

9. Use an approved sanitizing solution ratio noted below;

Amount of Luke Warm Water	Amount of Sanitizer
1 gallon (4 Liters)	Approved sanitizer solution that provides 100 ppm available chlorine

10. Remove ice agitator. Descale, rinse and sanitize the ice agitator.
11. Remove the dispense wheel assembly.
12. Locate small washer, it will be stuck to the bushing or inside the agitator shaft.
13. Soak the following parts for 20 minutes in descaling solution then rinse thoroughly;
 - 2 Chute Parts
 - Gasket
 - Dispense Wheel & Housing
 - Small Washer
14. Soak the removed parts in sanitizing solution for 10 minutes and wipe them down.

NOTE: If solution is left on these parts, they will rust.

15. Wipe the inner ice bin wall with descaler solution. Rinse and wipe dry. Repeat with sanitizer solution. Rinse and wipe dry.

16. With a bottle brush, brush the ice nozzle at bottom of ice bin with descaler solution. Rinse and wipe dry. Repeat with sanitizer solution. Rinse and wipe dry.
17. Replace all cleaned parts in their correct positions:
 - Small Washer
 - Assembled Dispense Wheel/Plates
 - Auger
 - Bin Cover
 - Motor
 - Gasket
 - Ice Chute
 - Ice Chute Cover.
18. Replace the unit top with four thumbscrews.
19. Restore power to the unit and turn ON the ice maker power switch.

Annual Planned Maintenance

Planned maintenance is most cost effective way of maintaining optimum machine life while minimizing unscheduled down time.

Some parts will need period inspection and replacement.

A schedule will be issued to the customer.

This Page Intentionally Left Blank

Operation

Touch Screens

The “easy ToUCH” screen has four selections. One for the drink making procedure, drink selection displays by default at start-up. The Manager’s Menu for accessing the machine’s settings. Inventory for product information and cleaning for routine maintenance of the machine.

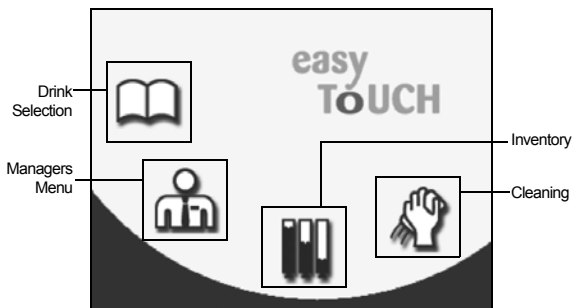

Main Menu Screen

- **Drink Selection**
See “Drink Selection Screen” on page 162.
See “Flavor Selection Screen” on page 163.
See “Size Screen” on page 164.
See “Main Menu Screen” on page 168.
- **Manager’s Menu**
See “Main Menu Screen” on page 168.
See “Manager’s Menu Screen” on page 169.
- **Inventory**
See “Main Menu Screen” on page 168.
See “Product Inventory Screen” on page 200.
- **Cleaning**
See “Main Menu Screen” on page 168.
See “Cleaning Screen” on page 204.

DRINK SELECTION SCREEN

The Drink Selection screen appears on power-up (except where clean/sanitize limitations have been exceeded, in which case the clean/sanitize screen appears). See Maintenance for Daily and Weekly cleaning/sanitization. This screen's primary function is to select a drink to make or access the Main Menu.

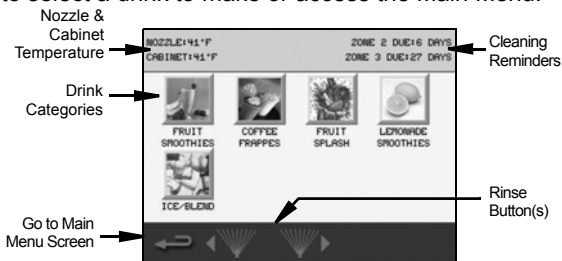

How to Access

The Drink Selection screen displays by default unless cleaning is required. This screen can also be accessed through the Main Menu Book Icon.

Icon Button Descriptions

- **Nozzle & Cabinet Temperatures**
Displays the current temperature for dispense point nozzle and the refrigeration cabinet. Unit of measure can be changed in the Manager's Menu.
- **Drink Categories**
The main product categories are displayed left to right on the Drink Selection screen. Touching a category will display the drink flavor options available for the category.

NOTE: Available drink selections may vary depending on the recipe file installed.

- **Main Menu Arrow**
Navigates to the Main Menu screen.
- **Cleaning Reminders**
Displays the time remaining in days until Zone 2 (Weekly) and Zone 3* (Monthly) cleaning is required. * If equipped with this feature.
- **Rinse Button**
Press to rinse the left or right blender chambers. Blend chamber door(s) must be closed.

FLAVOR SELECTION SCREEN

The Flavor Selection screen appears after a Drink Selection has been made. Flavor options will vary depending on what recipes are configured on the unit. This screen's primary function is to select a drink flavor.

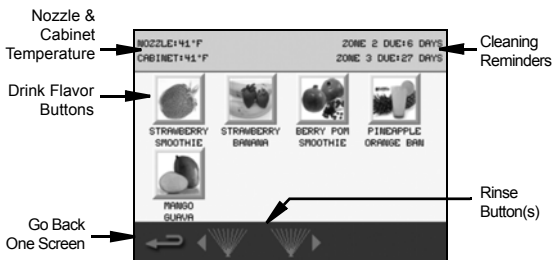

How to Access

The Flavor Selection screen displays after a drink selection has been made from the Drink Selection screen.

Icon Button Descriptions

- **Nozzle & Cabinet Temperatures**
Displays the current temperature for dispense point nozzle and the refrigeration cabinet. Unit of measure can be changed in the Manager's Menu.
- **Drink Flavor Buttons**
Flavor choices for the drink type that was selected.
 - **Yellow Border**
If any of the drink's ingredients will expire soon, the yogurt has expired, or there is less than 10% left in the product bag. Check the Product Inventory Screen for exact amount of product remaining.
 - **Red Border**
Product expired or product bag empty, flavor selection unavailable. Will need to replace product bag.

NOTE: Available flavor selections may vary depending on the recipe file installed.

- **Back Arrow**
Navigates to previous Drink Selection screen.
- **Cleaning Reminders**
Displays the time remaining in days until Zone 2 (Weekly) and Zone 3* (Monthly) cleaning is required. * *If equipped with this feature.*
- **Rinse Button**
Press to rinse the left or right blender chambers. Blend chamber door(s) must be closed.

SIZE SCREEN

The Size screen appears after a drink flavor has been chosen from the Flavor Selection Screen. This screen's primary function is to select size and make a drink, optional Add-Ins are also performed through this screen if the drink requires them.

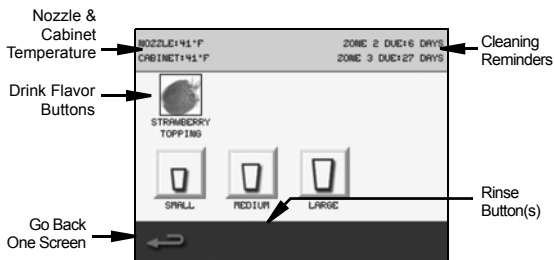

How to Access

The Size Selection screen displays after a flavor selection has been made from the Flavor Selection screen.

Icon Button Descriptions

- **Nozzle & Cabinet Temperatures**
Displays the current temperature for dispense point nozzle and the refrigeration cabinet. Unit of measure can be changed in the Manager's Menu.
- **Add-Ins**
These are not functioning buttons, only a graphic representation of the add-in used when making the selected drink. The screen will prompt the user when the add-in is to be added to the drink.

NOTE: Not all drinks have an add-in. Drink add-ins may vary depending on the recipe file installed.

- **Drink Size Buttons**
Press a drink size (Small, Medium, or Large) to start the drink making process. Once one is selected the screen will prompt the user to place the correct cup size in the dispense area. With the correct cup in place, press the green check to dispense product/ice into the cup or press the red X to cancel and return to the Size Selection Screen. (See Procedure to Make a Drink)
- **Back Arrow**
Navigates to previous Flavor Selection screen.
- **Cleaning Reminders**
Displays the time remaining in days until Zone 2 (Weekly) and Zone 3* (Monthly) cleaning is required.
- ** If equipped with this feature.*

Procedure to Make a Drink

NOTE: Ice must be present either in the ice bin or ice hopper (if the unit is a manual fill), product must be connected, and primed to produce a drink.

1. From the Main Menu screen, press the Open Book icon.



2. Select a category of drink recipes.

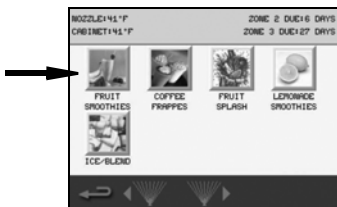

3. Specific drink combinations are displayed on the next screen. If a drink is not available it will be highlighted with a red square around it. Unavailable flavors may be out of product or unassigned.

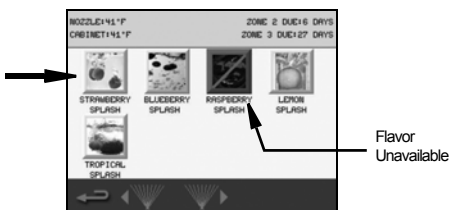

Continued on next page ...

4. Drink size is the next selection.

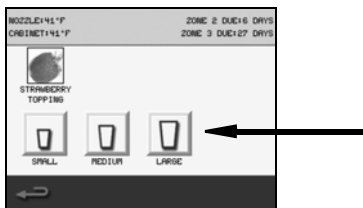

5. Place cup under center dispenser and press the green check.

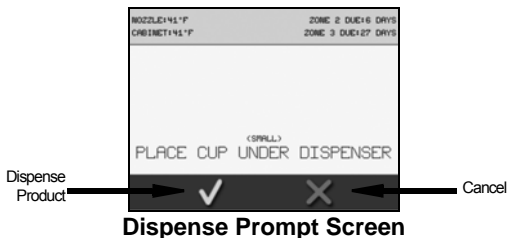

- As the flavor dispenses into the cup, the screen will display DISPENSING.
- If Add-in ingredients need to be manually added, the screen will give specific directions. More ingredients may be required later, follow the screen directions.
- Choose an available mixer, place the cup into the blender chamber, and shut the door. Press the corresponding right or left flashing green/blue arrow.



Continued on next page ...

9. While the drink is mixing, the top of the screen will read BLENDING.

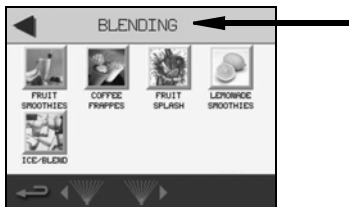

Drink Selection “BLENDING” Screen

10. Follow all drink specific screen directions for add-ins if necessary and press the flashing arrow if prompted.



Drink Selection “Add-In” Screen

11. When the blender is done mixing. Open the door and remove the drink. The blending station will go through a wash, rinse and sanitize cycle after the door is closed again.

MAIN MENU SCREEN

Accessed primarily through the Drink Selection screen, this screen's primary function is to provide access to all other procedures and adjustments that can be performed on the unit.



How to Access

Normally accessed through the Return Arrow in the bottom left of the Drink Selection screen.

Category Icon Descriptions

- **Drink Recipes Menu**
Displays the Drink Selection Screen.
- **Managers Menu**
Displays a Password Keypad screen, when password is correctly entered a menu of protected information for a manager will display.
- **Inventory**
Displays the remaining percentage of product in each bag, cabinet and product tubes temperature readings.
- **Cleaning**
Displays the Cleaning Screen and gives the options for Zone 1 (Daily), Zone 2 (Weekly), or Zone 3* (Monthly) Cleaning and Product Line Flushing. * *If equipped with this feature.*

MANAGER'S MENU SCREEN

Accessed through the Main Menu screen, this screen's primary function is to provide on screen access to Manager only functions.

How to Access

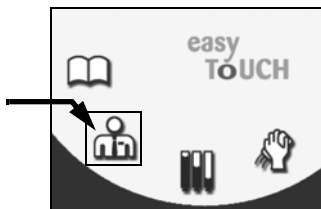

After selecting Manager's Menu icon from the Main Menu the password screen appears. The manager screens are password protected. (Default Password is "A") Enter the Manager's pass code using the QWERTY keypad then press the green check to accept.

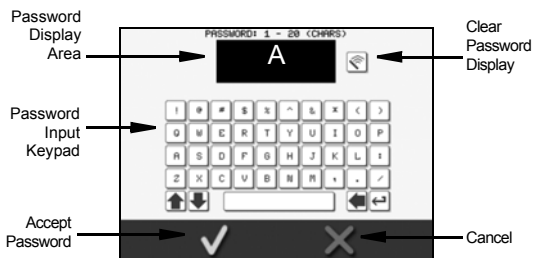

After typing in the correct password, Language, Date/ Time, Temperatures, Edit Password, Configure Slots, Updates, Auto Wash Timer and Service screens are accessible. When the manager screens are inactive for a time period, the screen will return to the drink menu.

Important

Do not change the language, edit the password or configure the slots unless instructed to do so by the factory.

Manager Menu Features

• Manager Screen 1



- Language (“Changing the UI Language” on page 172)
- Date & Time Settings (“Date & Time Setting” on page 173)
- Temperatures (“Temperature Setting” on page 175)
- Edit Password (“Edit Password Setting” on page 176)
- Configure Slots (“Configure Slots Setting” on page 178)

• Manager Screen 2

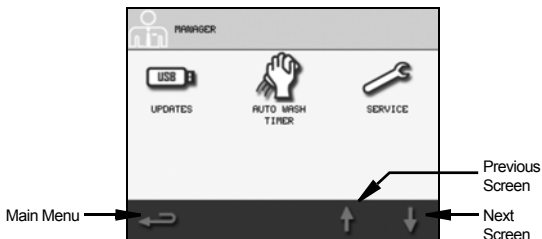

- Updates (“Updates” on page 185)
- Auto Wash Timer (“Auto Wash Timers” on page 193)
- Service (“Service Screens” on page 194)

• Manager Screen 3

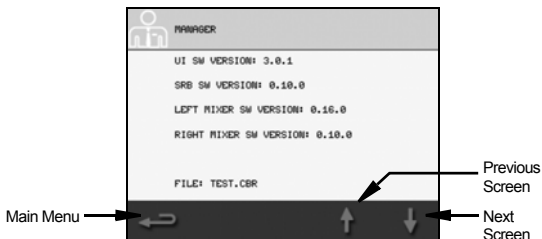

This screen displays all current software versions on the unit.
(See “Software Version Screen” on page 197.)

- **Manager Screen 4**

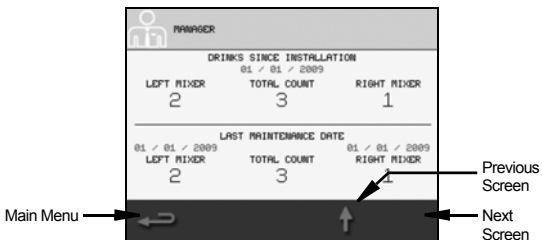

This screen displays the drink counter.
(See "Drink Counter Screen" on page 198.)

Changing the UI Language

Important

Do not change the language unless instructed to do so by the factory.

These steps are to be followed once the user has gained access to the Manager's Menu by entering the correct pass word (Default Password is "A").

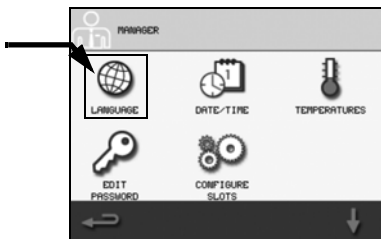

1. Select the Language icon from the first Manager's Menu screen.



Language Selection Screen

2. Select a language, a green check box indicates what language is currently selected.
3. Press the Return Arrow in the lower left corner to save and return to the first Manager's Menu screen.
4. Press the Return Arrow again to return to the Main Menu.

Date & Time Setting

Important

Set the correct date and time at installation. Correct the date or time when necessary.

These steps are to be followed once the user has gained access to the Manager's Menu by entering the correct pass word (Default Password is "A").

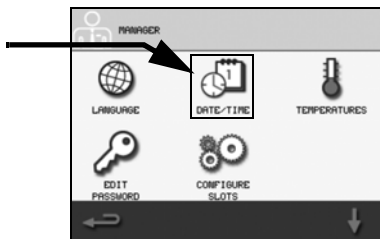

1. Select the Date/Time icon from the first Manager's Menu screen.

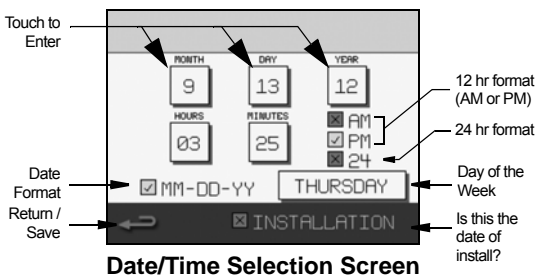

Date/Time Selection Screen

- Choose the date format that will be used on the machine; MM-DD-YY.
 - To enter the Month, Day, Year, Hours, or Minutes, touch the corresponding box, type in the correct number, and press the green check to accept.
 - If using 12 hr time format, select AM or PM. If using 24 hr format select the 24 check box.
 - Only select the Installation check box if this will be the installation date/time.
2. Select the Return/Save arrow when done.

Continued on next page ...

3. If changes were made the following screen will display;



Save Settings Screen

- Press SAVE to save the new settings.
 - Press DISCARD to cancel any changes.
 - The Manager's Menu will appear after a selection has been made.
4. Press the Return Arrow again to return to the Main Menu.

Temperature Setting

These steps are to be followed once the user has gained access to the Manager's Menu by entering the correct pass word (Default Password is "A").

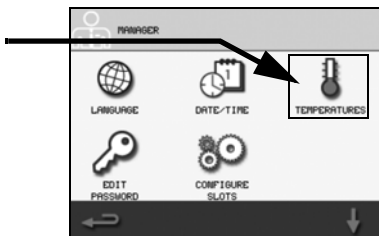

1. Select the Temperatures icon from the first Manager's Menu screen.

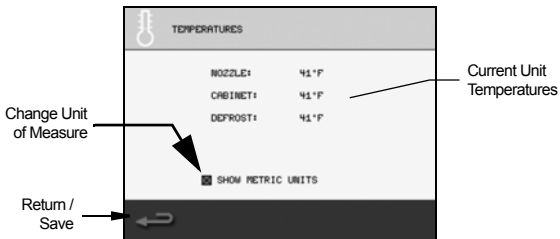

Temperature Screen

- The screen will display the current Nozzle, Cabinet, and Defrost temperature readings.
- To change to Celsius Metric Units of measure, press the check box next to SHOW METRIC UNITS, a green check box means Metric has been selected.
- Press the Return Arrow to return to the previous screen.

Edit Password Setting

Important

Only a trained manager or authorized technician should change the default password. Be sure to keep record of the new password.

These steps are to be followed once the user has gained access to the Manager's Menu by entering the correct pass word (Default Password is "A").

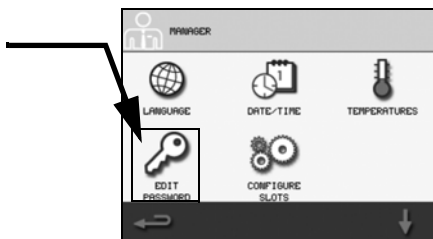

1. Select the Edit Password icon from the first Manager's Menu screen.

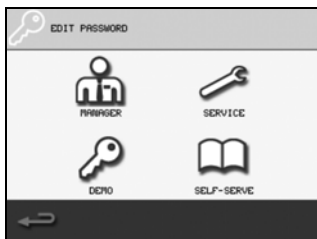

Edit Password Screen

- Choose which password to change, Manager, Service, Demo, or Self-Serve.

NOTE: If changing all passwords they each have to be selected and changed one at a time.

Continued on next page ...

2. Enter the current password, "A" is the factory default for all password protected areas.

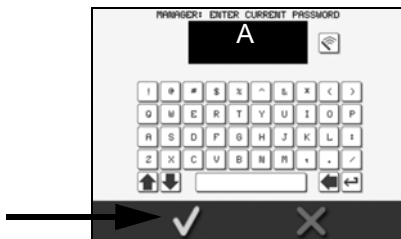

Current Password Screen

- Press the green check to continue.
3. Enter the new password, anything from 1-20 characters.
 - Press the green check to continue.
 4. Confirm the new password by entering it again.
 - Press the green check to confirm and finish changing the password.
 5. The Manager's Menu Screen will appear.
 6. Press the Return Arrow to go back to the Main Menu.

Configure Slots Setting

These steps are to be followed once the user has gained access to the Manager's Menu by entering the correct pass word (Default Password is "A").

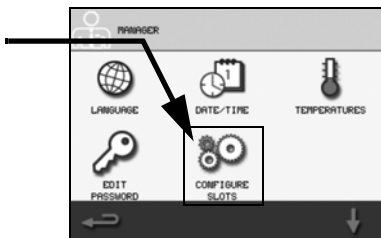

1. Select the Configure Slots icon from the first Manager's Menu screen. There are two submenus, SLOT FLAVOR and CALIBRATE FLAVOR.

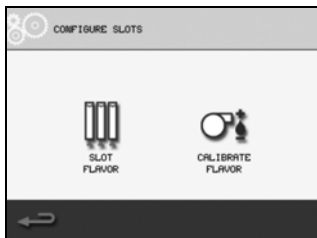

Configure Slots Screen

- The SLOT FLAVOR icon is used to assign flavors to each product slot on the machine. See "Assigning Flavors" on page 179.
- The CALIBRATE FLAVOR icon is used for calibration of each assigned flavor. Calibrate Flavor is a process to ensure the machine is dispensing the correct amount from each product slot, water and ice. See "Calibration Procedure" on page 181.

ASSIGNING FLAVORS

1. Press the SLOT FLAVOR icon.

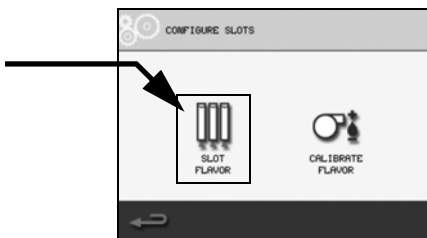

2. Select a slot you want to assign a flavor to.

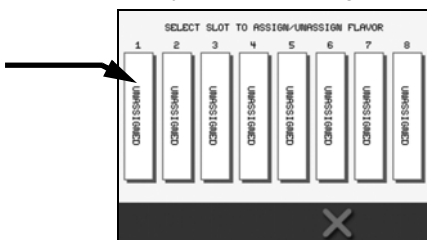

Select Slot Screen

3. Select from available flavors.

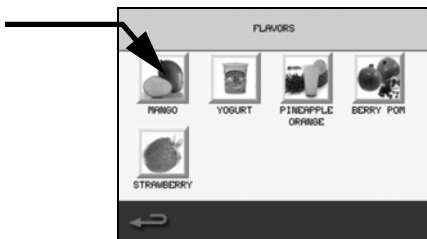

Select Flavor Screen

NOTE: Available flavors will vary depending on the recipe file that is loaded on the machine. Select Assign Flavor.

- Screen will return to the Slot Selection Screen.
- The flavor name will now display and the slot will be highlighted green.

Continued on next page ...

- Continue to select slots and flavors until all slots are assigned.

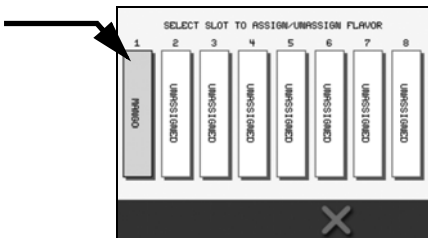

Select Flavor Screen

- Select the red X when finished to return to the Configure Slots screen. Select the return arrow twice to return to the Main Menu.

CALIBRATION PROCEDURE

1. Press the CALIBRATE FLAVOR icon.

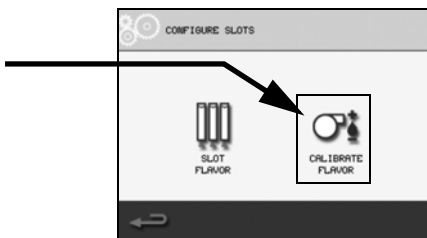

2. Select a flavor, water or ice to calibrate.

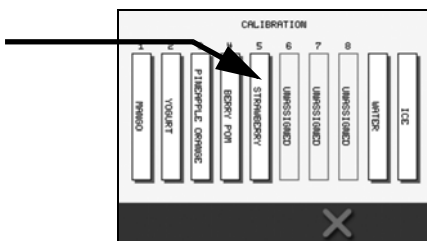

Choose Slot to Calibrate

3. Follow the on screen instructions and do the following;

- Get a scale.
- Tare empty cup weight.
- Position an empty cup for dispense.

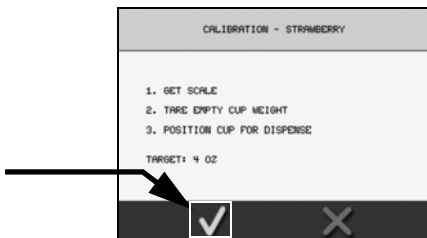

Choose Slot to Calibrate

- Press green check when ready.

4. Wait until dispensing is done.

5. Weigh cup.

NOTE: Flavor and water target is 4 oz. Ice target is 6 oz.

6. Touch the Enter Weight button.

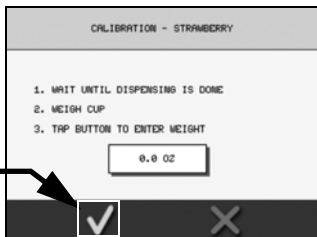

Calibration Screen 2

- Enter the cup weight using the number pad.

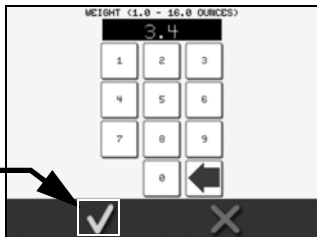

Enter Weight Screen

- Select the green check when done to continue.

NOTE: If the weight entered was not 4 oz. for a flavor/water or 6 oz. for ice the unit will electronically adjust the dispense calibration based on the weight entered to obtain the correct target dispense weight. No mechanical adjustments are required.

7. The calibration screen will display again with the weight entered on the previous screen.

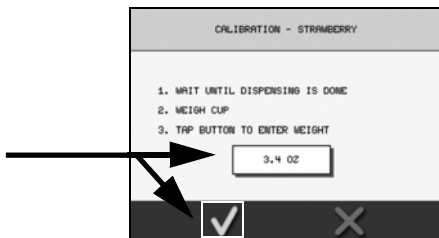

Calibration Screen 2

- If the weight displayed is incorrect, press the Enter Weight button again and re-enter.
- Press green check when done to save and complete calibration for the slot.

8. The Calibration Complete screen will display.

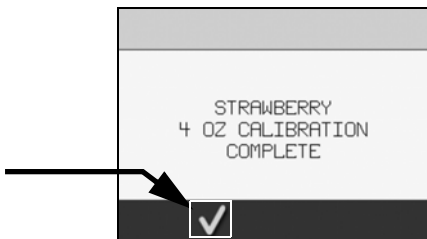

Calibration Complete Screen

- Press green check to return to the Calibration Slot Choice screen.

NOTE: The newly calibrated slot will be highlighted in green.

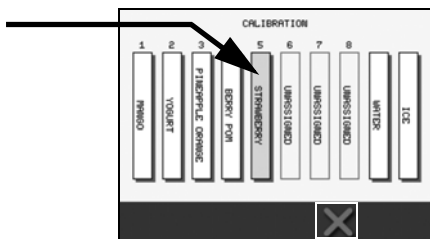

Calibration Slot Choices Screen

9. Chose another flavor, water or ice to calibrate or return to the Configure Slots screen by pressing the red X.

Updates

Firmware and Recipes Screens allow the manager to plug a USB flash drive in and upload new firmware and recipes.

Important

Only a trained manager or authorized technician should perform USB updates. If updates are not performed properly they can cause the unit to malfunction or not work at all.

These steps are to be followed once the user has gained access to the Manager's Menu by entering the correct pass word (Default Password is "A").

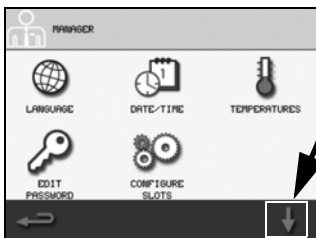

1. Press the Page Down Arrow.

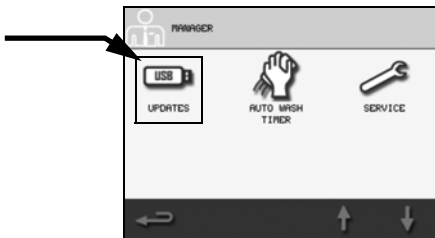

- Press the UPDATES icon.

Continued on next page ...

2. There are two submenus, FIRMWARE and RECIPES.

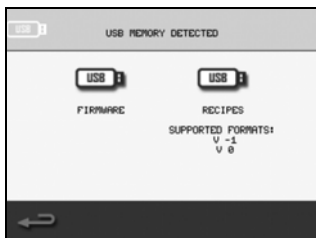

Updates Screen

- The FIRMWARE icon is used to update the “easy ToUCH” user interface, Dispenser, and/or the Mixers firmware on the machine.
See “Firmware Update Procedure” on page 187.
- The RECIPES icon is used to update or change the available drink flavors and combinations.
See “Recipe Loading Procedure” on page 190.

FIRMWARE UPDATE PROCEDURE

Important

1. Read Instructions Completely
2. Firmware file (.bin) must be loaded on top level of flash drive.
3. Require only 1 firmware (.bin) file on the flash drive at a time. If multiple firmware (.bin) files are on the flash drive, the first one in alphabetical order would be loaded and may not be the current version.
5. Flash Drive must be formatted to FAT or FAT32 file format. (Typical for smaller flash drives <2GB).

1. Plug in the properly formatted Flash Drive containing the firmware bin file, the USB port is located on the left hand side of the unit to the left of the power switch.

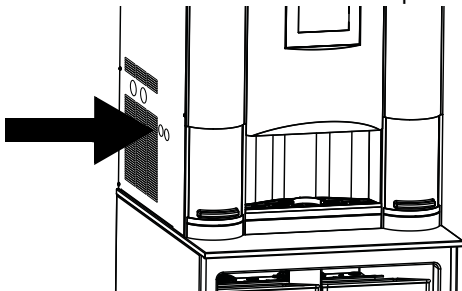

2. From the Main Menu, press the Manager's icon and enter the password. (Default password is "A")

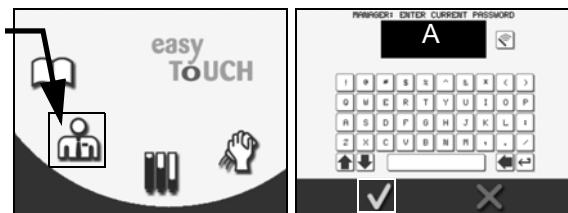

- Press the green check.

Continued on next page ...

3. Press the Page Down Arrow.



4. Press the UPDATES icon.

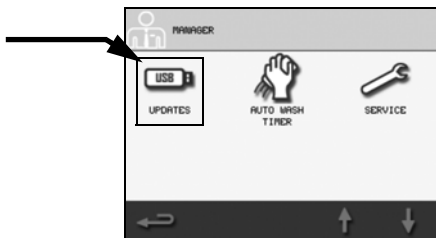

5. Press the FIRMWARE icon.

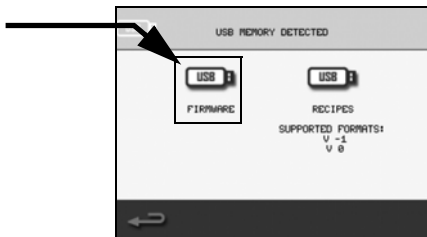

6. Choose which firmware is being updated, User Interface, Dispenser, or Mixers.

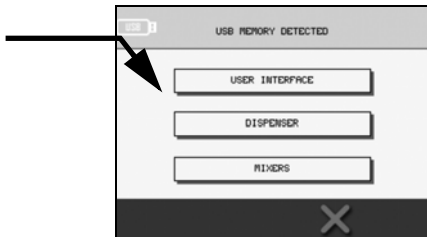

Continued on next page ...

7. Verify version to be loaded is correct.

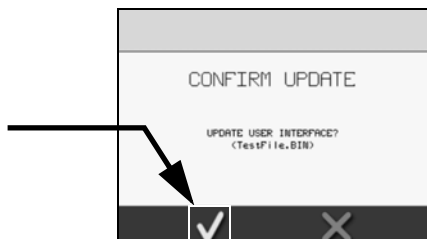

- Press the green check to begin loading new firmware.
8. Firmware will show status of update as a percentage, and screen will display "UPDATE COMPLTE" when finished, back out to the front screen before removing flash drive

Important

You must **CYCLE POWER** to the unit after a firmware update before the firmware will take effect.

RECIPE LOADING PROCEDURE

Important

1. Read Instructions Completely
2. Recipe file (.cbr) must be loaded on top level of flash drive.
3. Require only 1 recipe (.cbr) file on the flash drive at a time. If multiple firmware (.cbr) files are on the flash drive, the first one in alphabetical order would be loaded and may not be the correct version.
5. Flash Drive must be formatted to FAT or FAT32 file format. (Typical for smaller flash drives <2GB).

1. Plug in the properly formatted Flash Drive containing the firmware bin file, the USB port is located on the left hand side of the unit to the left of the power switch.

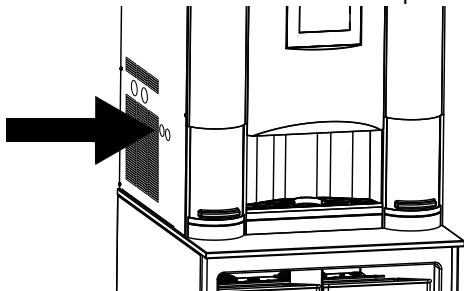

2. From the Main Menu, press the Manager's icon and enter the password. (Default password is "A")

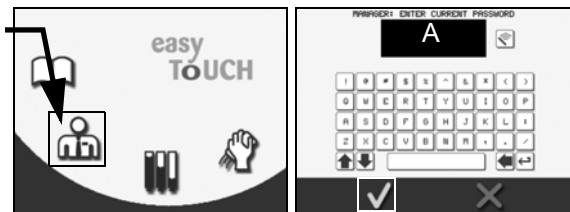

- Press the green check.

Continued on next page ...

3. Press the Page Down Arrow.



4. Press the UPDATES icon.

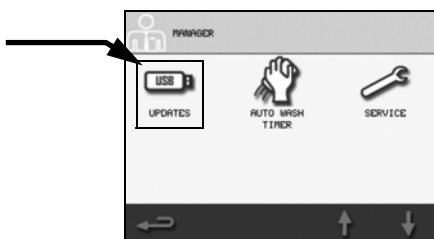

5. Press the RECIPES icon.

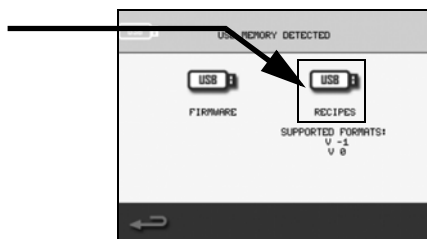

6. Press UPDATE RECIPES FROM USB.

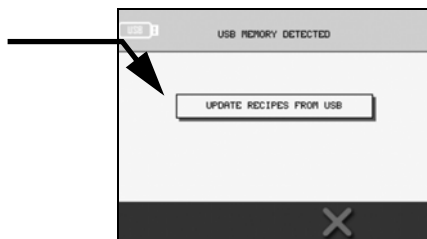

Continued on next page ...

7. Verify version to be loaded is correct.

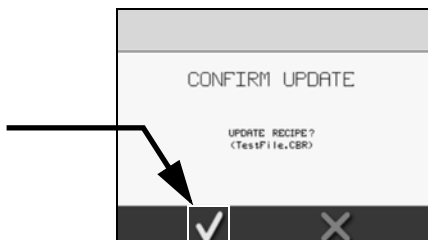

Confirm Update Screen

- Press the green check to begin loading recipe file.

8. Recipe will show status of update as a percentage, and screen will display "UPDATE COMPLTE" when finished.

Important

You must **CYCLE POWER** to the unit after a recipe update before the recipe file will take effect.

Auto Wash Timers

Allows the manager to turn ON / OFF, and set up periodic automatic wash cycles for the blender stations. Up to six (6) timers can be set.

These steps are to be followed once the user has gained access to the Manager's Menu by entering the correct pass word (Default Password is "A").

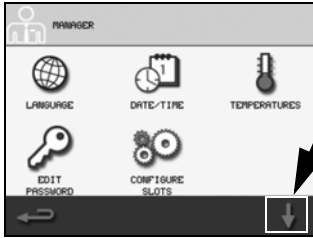

1. Press the Page Down Arrow.

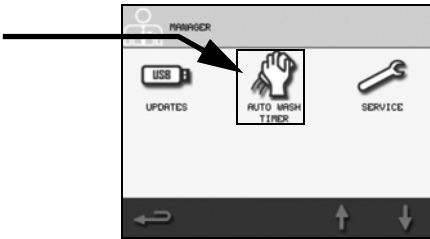

- Press the AUTO WASH TIMER icon.

2. By default no timers are preset.

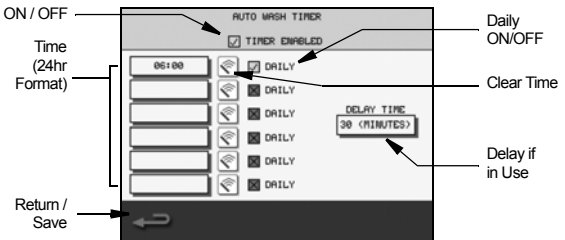

Auto Wash Screen

3. To save any changes, press the Return Arrow and return to the Manager's Menu. When exiting the Manager's Menu all changes will be confirmed.

Service Screens

Allows the manager and qualified service technician access to optional functions, settings, input, and output readings used in both setup and diagnostics.

Important

Only a trained manager or authorized technician should access the service screens. If changes to these settings are made incorrectly they can cause the unit to malfunction or not work at all.

These steps are to be followed once the user has gained access to the Manager's Menu by entering the correct pass word (Default Password is "A").



1. Press the Page Down Arrow.

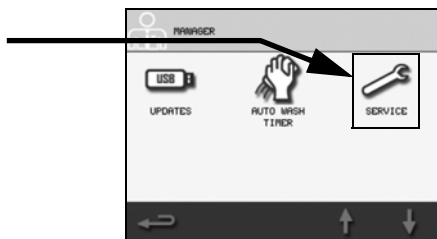

- Press the SERVICE icon.

Continued on next page ...

2. The service screens are password protected, enter the service password (default password is "A").

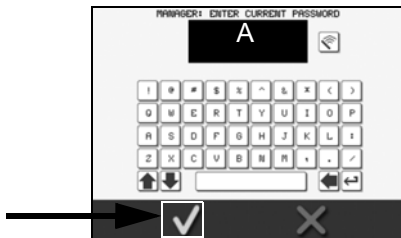

- Press the green check.

3. The following choices will be made available;

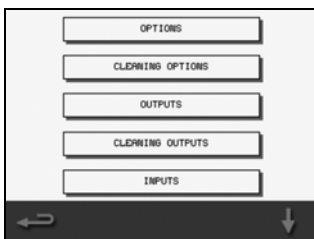

- **OPTIONS**
Turn ON/OFF the following; Mixer Rinse, Water Saving Rinse, Left Mixer, Right Mixer, Condenser Filter(s)
- **CLEANING OPTIONS**
Set Zone 2 and 3 timer durations. Enable sanitizing in Zone 2 cleaning. Enable Descaling in Zone 3 cleaning.
- **OUTPUTS**
Displays current state of all drink component outputs and can be toggled ON/OFF from this screen.
- **CLEANING OUTPUTS**
Displays current state of all cleaning component outputs and can be toggled ON/OFF from this screen.
- **INPUTS**
Displays current state of all input components.
- **Press the down arrow for more choices**

4. The second screen displays more service choices;

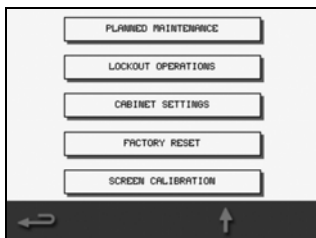

- **PLANNED MAINTENANCE**
Password protected screen only meant for the service technician performing the planned maintenance.
- **LOCKOUT OPERATIONS**
DEMO mode will password protect all icons once the user saves settings and returns to the Main Menu. Enter "DEMO" in the password screen to gain temporary access to the Drink, Inventory, and Cleaning screens. "A" is the default password for the Manager's Menu.

SELF-SERVE mode will limit the user to just drink making screens and password protect the Main Menu. Enter "SELF" in the password screen to gain temporary access to the Main Menu. "A" is the default password for the Manager's Menu.

- **CABINET SETTINGS**
Displays all current cabinet settings, touch a setting to change its value.
- **FACTORY RESET**
Resets all calibrations to factory settings.

 **Warning**

This will erase all settings that have been set manually.

- **SCREEN CALIBRATION**
Calibrates the touch screen sensitivity.

Software Version Screen

Allows the manager and qualified service technician to see on screen what software versions are currently installed.

These steps are to be followed once the user has gained access to the Manager's Menu by entering the correct pass word (Default Password is "A").



1. Press the Page Down Arrow.

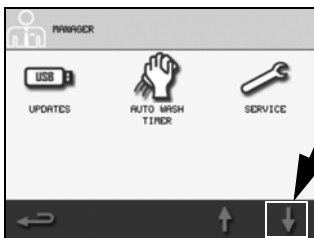

2. Press the Page Down Arrow.

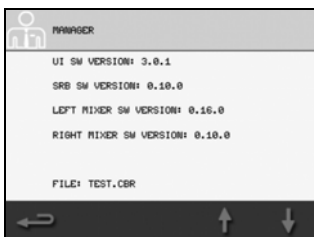

Software Version Screen

3. The screen will display the loaded software version numbers for the UI, SRB, Left & Right Mixer, and current recipe file name.

Drink Counter Screen

Allows the manager and qualified service technician to see on screen how many drinks the unit has made since installation and last maintenance date.

These steps are to be followed once the user has gained access to the Manager's Menu by entering the correct pass word (Default Password is "A").



1. Press the Page Down Arrow.

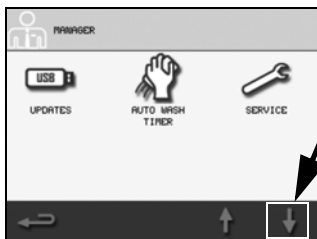

2. Press the Page Down Arrow.



3. Press the Page Down Arrow.

Continued on next page ...

4. The screen will display how many drinks each mixer has made and the total count.

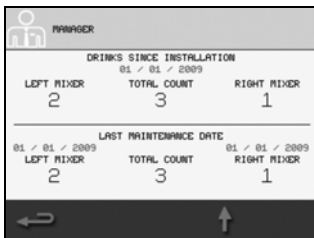

The screenshot shows a 'MANAGER' screen with a person icon. It displays drink counts since installation and last maintenance dates for left and right mixers. The data is as follows:

DRINKS SINCE INSTALLATION		
01 / 01 / 2009		
LEFT MIXER	TOTAL COUNT	RIGHT MIXER
2	3	1

LAST MAINTENANCE DATE		
01 / 01 / 2009		
LEFT MIXER	TOTAL COUNT	RIGHT MIXER
2	3	1

At the bottom of the screen, there is a dark bar with a left-pointing arrow on the left and an up-pointing arrow on the right.

Drink Counter Screen

PRODUCT INVENTORY SCREEN

This screen's primary function is to provide visual product inventory information for the user. The Product Inventory screen is normally accessed through the Main Menu.

How to Access

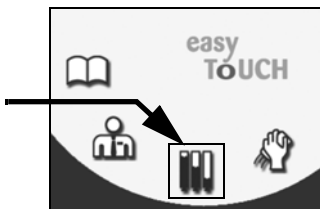

1. Press the Inventory Icon from the Main Menu.

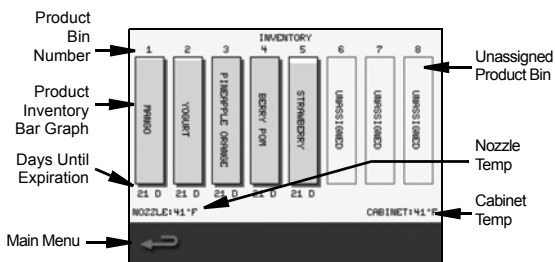

The inventory screen visually displays levels for all flavors. Underneath each flavor is the time remaining until the flavor expires in days. Nozzle and cabinet temperatures are also on the inventory screen. When a flavor is touched on the screen the instructions to replace a product bag will begin.

Icon Button Descriptions

- **Product Bin Number**
Displays the product bin number the Product Inventory Bar Graph represents.
- **Product Inventory Bar Graph**
Product inventory tracking estimates the remaining flavoring in each product's bag in the reach-in compartment in 5% increments.
 - **Green Bar**
Product inventory is above 10% and not near expiration.
 - **Yellow Bar**
Product inventory has fallen below 10% or less than 24 hours until expiration, a message appears on the Drink Selection screen for the affected drink(s).
 - **Red Bar**
If the bar representing a product's inventory level is red, the bag is empty or expired, replace product. (See "Procedure to Install a Product Bag" on page 202.)
 - **UNASSIGNED**
If UNASSIGNED is displayed below the product bin number, no product is currently assigned to the bin.
- **Nozzle Temperature**
Displays the current temperature near the dispense point. Can be set to Celsius or Fahrenheit in the Manager's Menu. (See "Temperature Setting" on page 175.)
- **Back Arrow**
Navigates to previous Main Menu screen.
- **Days Until Expiration**
Displays the number of days remaining until the product bag expires. Pressing the corresponding product bar graph will access the Replace Product screen, displaying the steps to follow for replacement. (See "Procedure to Install a Product Bag" on page 202.)
- **Cabinet Temperature**
Displays the current temperature in the refrigeration cabinet. Can be set to Celsius or Fahrenheit in the Manager's Menu. (See "Temperature Setting" on page 175.)

Procedure to Install a Product Bag

1. From the Main Menu touch the inventory icon.

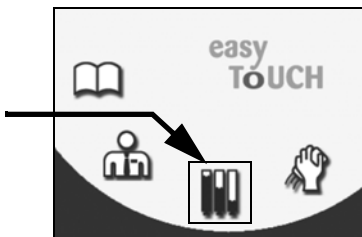

2. On the inventory screen select the product to be installed.

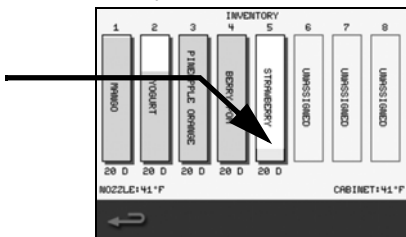

- Products with less than 10% inventory or less than 24 hours until product expires will be displayed with a yellow bar.
- Products that are expired will be displayed with a red bar.

3. Follow the on screen instructions.

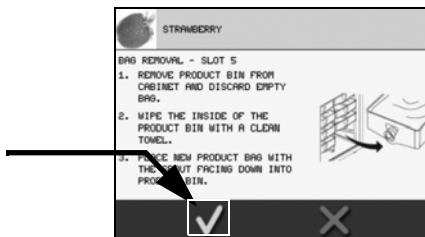

4. Remove product bin from cabinet and discard empty bag.
 5. Wipe the inside of the product bin with a clean towel.
 6. Place new product bag with the spout facing down into product bin.
- Press the green check to continue.

7. Position rear groove of the spout on product bag into slot of the product bin.

Important

The spout must snap into the slot of the product bin!

8. Open the cap on the product bag and tear it off.
9. Return product bin to its position in cabinet.
 - Press the green check to continue.
10. Select inventory level from full bag, prime flavor or no bag.

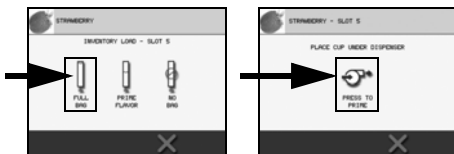

Inventory Load & Prime Screens

- Select FULL BAG when installing a new product bag and the Prime screen will display.
11. Place cup under dispenser and press the PRIME icon to prime the line with the new product bag, DISPENSING will display on the screen. Repeat until product consistently flows into the cup.
 - Press the green check to continue and return to the inventory screen.

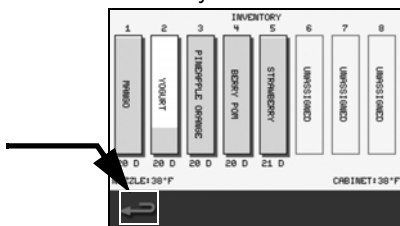

12. Installation is now complete, the inventory bar will now display full, green, and days until expiration reset.
13. Select another product to be installed or return to the previously active screen by pressing the Return Arrow.

Important

Resetting a product's inventory without replacing the product bag will cause the Product Inventory screen, percentages, and life to be inaccurate.

CLEANING SCREEN

The Cleaning screen appears after selected from the Main Menu or when prompted to perform routine cleaning. This screen's primary function is to perform routine cleaning and sanitation of the machine.

How to Access

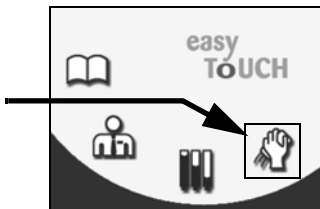

1. Press the Cleaning Icon from the Main Menu.

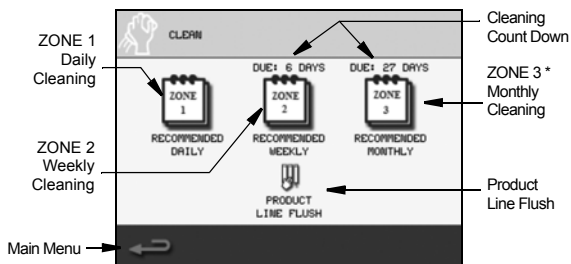

Icon Button Descriptions

- **ZONE 1 - Daily Cleaning**
Displays the Daily Cleaning screen and guides the user through all daily cleaning requirements.
See "Daily Cleaning - Zone 1" on page 54.
- **ZONE 2 - Weekly Cleaning**
Displays the Weekly Cleaning screen and guides the user through all weekly cleaning requirements.
See "Weekly Cleaning - Zone 2" on page 67.
- **ZONE 3 - Monthly Cleaning ***
Displays the Monthly Cleaning screen and guides the user through all monthly cleaning requirements. These screens will only appear on units with the Clean In Place feature.
See "Monthly Cleaning - Zone 3" on page 100.
- **Back Arrow**
Returns to the previous screen or Main Menu.
- **Cleaning Count Down**
Days left until Cleaning is required. Shown in Day increments, changes to Hours when there is less than a day (24 hours) until cleaning of the machine is required. Resets once cleaning has been completely performed.

Important

Once the time limit has been exceeded the machine will no longer make a drink until cleaning has been completed.

- **Product Line Flush**
Displays the Product Line Flush screen and guides the user on how to flush all product lines.
See "Product Line Flush" on page 137.

Ice Making Sequence of Operation

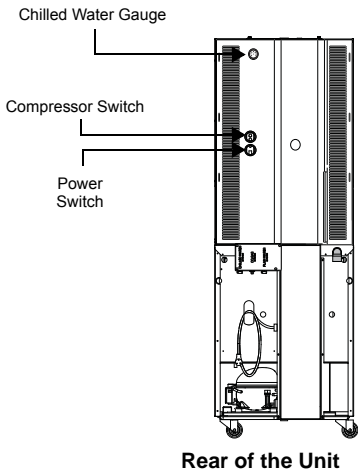

ICE MACHINES R290 REFRIGERANT

Models: MB-8-1PP

NOTE: Ice machines use an auger to remove ice from the evaporator. Occasional noises (creaks, groans, squeaks, or pops) are a normal part of the ice making process.

Operation

The ice machine will not start until:

- A. The compressor rocker switch is moved to "ON".
- B. Ice does not contact the bin level sensor.
- C. The water reservoir is full of water.

With power supplied and the compressor rocker switch in the ON position, the gear motor and refrigeration system start. The float valve controls the water inlet valve and water level. The freeze cycle ends when the ice reaches the ice bin level sensor.

Product Dispense Operation

The sequence varies according to the recipe. Some recipes will use one ingredient, others will use multiple ingredients. The sequence below uses one ingredient to simplify the sequence.

Prerequisites

- Line voltage must be supplied
- CO₂ pressure is supplied and regulated to the correct pressure
- Product is inserted in cabinet and correctly connected to adapter/tubing
- Ice is available
- Water is supplied at the correct pressure
- A recipe has been developed in MenuConnect and transferred to the control board with a USB drive.

OPERATION

Selecting a drink from the touch screen will energize the following components for the time specified by the recipe:

- A. The ice dispense wheel turns to add ice.
- B. The water inlet valve opens to dispense water.
- C. The solenoid valve opens and supplies CO₂ to the product pump
- D. The product pump energizes and pumps the product into the cup.

The cup is then transferred to a blending station.

Refrigerated Cabinet Operation

Default temperature set point = 2.2°C / 36° F with a 2.2°C / 4° F Differential.

Parameter	Default Setting	Minimum Setting	Maximum Setting
Set-point (°F)	36	32	38
Differential (°F)	4	1	6
Minimum Off Time (Min)	3	2	5
Defrost Run Time (Min)	180	120	600
Defrost Temperature (°F)	43	35	50
Defrost Time (Min)	15	10	20
Defrost initiation Temperature (°F)	5	-15	12
Default On Time (Min)	12	10	20
Default Off Time (Min)	3	2	5

NORMAL OPERATION

The microprocessor control board controls the cabinet temperature based on the input received from the cabinet temperature thermistor. The thermistor value is compared to the control board set point. When the reach-in temperature is equal or greater than the set point (plus half the differential) the compressor relay closes provided the following conditions are satisfied:

- Power has been uninterrupted to the control board for a 3 minute period.

OR

- The 3 minute compressor time delay has expired. The delay period starts after the compressor has run and then cycles off.

The compressor relay opens when the reach-in temperature is less than the set point (minus half the differential).

EVAPORATOR & CONDENSER FAN MOTOR OPERATION

The condenser fan motor and compressor share the same relay. The evaporator fan motor relay is energized continuously and the evaporator fan runs continuously.

OPERATION IN THE CLEAN/SANITIZE CYCLE

During the weekly cleaning/sanitize cycle, the evaporator fan motor relay and the condenser fan motor/compressor relay are remain energized.

ADAPTIVE DEFROST

After 3 hours of cumulative compressor run time, the compressor will be de-energized for fifteen (15) minutes.

HIGH TEMP ALARM

High temp alarm will display when product thermistor is above 5.5°C / 42°F for 30 minutes and the following conditions are satisfied:

- 3 hours since power is applied
- 1 hour since cleaning cycle

Error display will reset when the temperature reaches 5°C / 41°F or below.

THERMISTOR FAILURE

If the microprocessor control board receives an open or shorted cabinet thermistor signal, the following will happen:

1. A fault is displayed on the LCD screen
 - Cabinet sensor open

Or

- Cabinet sensor shorted
2. The microprocessor will initiate a default sequence for the refrigeration system - 12 minutes on, 3 minutes off.
3. The default cycle continues until the fault is corrected or power is disconnected. See "Temperature Thermistor - Nozzle, Cabinet or Defrost" on page 297.

Other Operations

RECOMMENDED CUPS

The following are cup general guidelines. Cups outside these parameters may work - testing in the machine with the product will be necessary.

- Cup heights between 4.25" and 7.00".
- Cup opening diameter greater than 3.50" and less than 4.18".
- Cup base diameter greater than 2.38" and less than 2.62".

Changing the Cup Dispenser Size

Turn the inner dial so that the notch sets at 1, 2, 3 or 4. Setting 1 will hold the smallest cup and 4 the largest cup. When the dial moves from 1 to 2, the dispenser fingers retract and allow for a larger cup to be inserted.

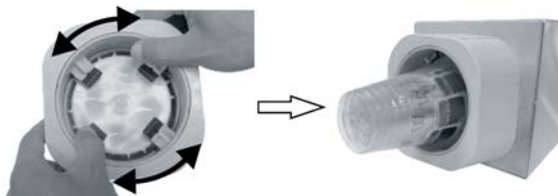

Position 1



Position 2

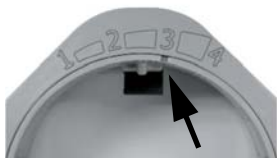







Position 3







Position 4



Display Errors

Screen	Display Shows	Error	Description of Error Condition	System Response to Error	Service
Drink Selection 	DEFROSTING	None	None	Normal operation	Refer to defrost chart in technical manual.
Drink Selection Temperatures Service Inputs 	CABINET PROBE FAILURE: CHECK CABINET TEMPERATURE	Base Sensor temperature will display Open / Shorted	Cabinet Sensor input to A/D open / shorted circuit detected.	System shall go into fail-safe refrigeration mode. Compressor on for 12 minutes, off for 3 minutes. Temperature display shall change to "OPEN / SHORTED".	Check connection onto SRB See "SRB Board" on page 275. Check sensor resistance See "Temperature/Resistance Chart" on page 298.
Drink Selection Temperatures Service Inputs 	NOZZLE SENSOR TEMPERATURE WILL DISPLAY OPEN / SHORTED	Nozzle Sensor temperature will display Open / Shorted	Nozzle Sensor input to A/D open / shorted circuit detected.	System shall go into fail-safe refrigeration mode. Compressor on for 12 minutes, off for 3 minutes. Temperature display shall change to "OPEN / SHORTED".	Check connection onto SRB See "SRB Board" on page 275. Check sensor resistance See "Temperature/Resistance Chart" on page 298.

Screen	Display Shows	Error	Description of Error Condition	System Response to Error	Service
Drink Selection Temperatures Service Inputs 	DEFROST TEMP 'OPEN / SHORTED'		Defrost Sensor input to A/D open / shorted circuit detected.	System shall go into fail-safe refrigeration mode. Compressor on for 12 minutes, off for 3 minutes. Temperature display shall change to "OPEN / SHORTED".	Check connection onto SRB See "SRB Board" on page 275. Check sensor resistance See "Temperature/ Resistance Chart" on page 298.
Drink Dispense 	ERROR HIGH PRODUCT TEMPORATURE	High Temperature	Cabinet or nozzle temperature high for extended time	Interrupt home screen and default screens only.	Check connection onto SRB See "SRB Board" on page 275. Check sensor resistance See "Temperature/ Resistance Chart" on page 298. Check refrigeration system, Air filter, fan, air restriction See "Refrigerated Cabinet" on page 297.
Drink Flavor & Inventory 	YELLOW BOARDER, YELLOW BAR	Near Expiration	2 hours left until product expiration.	Highlight icon(s) of drink(s) affected with Yellow border.	See "Procedure to Install a Product Bag" on page 202.

Screen	Display Shows	Error	Description of Error Condition	System Response to Error	Service
Drink Flavor & Inventory 	YELLOW BOARDER, YELLOW BAR	Inventory Low	Inventory low based on calculated remaining weight.	Highlight icon(s) of drink(s) affected with Yellow border	See "Procedure to Install a Product Bag" on page 202.
Drink Flavor & Inventory 	"INVALID RECIPE FLAVOR(S) NOT INSTALLED OR FLAVOR(S) EXPIRED OR SLOT NEEDS CLEANING FLAVOR X"	Expired Product	Product expired.	Displays "INVALID RECIPE FLAVOR(S) NOT INSTALLED OR FLAVOR(S) EXPIRED OR SLOT NEEDS CLEANING FLAVOR X"	See "Procedure to Install a Product Bag" on page 202.
Drink Dispense 	"WARNING ZONE 2 CLEANING DUE IN <u>XX HOURS XX MINUTES</u> "	Cleaning Warning	Within 8 hours of lockout.	Displays "WARNING ZONE 2 CLEANING DUE IN XX HOURS XX MINUTES"	See "Weekly Cleaning - Zone 2" on page 67.

Screen	Display Shows	Error	Description of Error Condition	System Response to Error	Service
<p data-bbox="270 191 452 212">Drink Dispense</p> 	<p data-bbox="609 253 825 326">"ERROR! ZONE 2 CLEANING EXPIRED"</p>	<p data-bbox="872 264 1021 315">Clean Timer Expired</p>	<p data-bbox="1054 264 1307 315">Zone 2 cleaning must be performed.</p>	<p data-bbox="1323 253 1556 326">Displays "ERROR! ZONE 2 CLEANING EXPIRED"</p>	<p data-bbox="1573 264 1832 315">See "Weekly Cleaning - Zone 2" on page 67.</p>
<p data-bbox="270 492 452 512">Drink Dispense</p> 	<p data-bbox="637 569 793 621">DISPENSER ERROR</p>	<p data-bbox="872 502 1029 694">System Relay Board out of sync. Communication lost between UI and SRB board</p>	<p data-bbox="1074 486 1287 709">Possible power glitch and UI board reset while SRB in dispense state OR SRB reset and UI expects SRB to be in some other state.</p>	<p data-bbox="1362 569 1519 621">DISPENSER ERROR</p>	<p data-bbox="1589 404 1818 792">Turn OFF power switch for 10 seconds turn ON Call For service Check connection onto SRB See "SRB Board" on page 275. Check UI board connections See "UI (User Interface - Touchscreen)" on page 271.</p>

Screen	Display Shows	Error	Description of Error Condition	System Response to Error	Service
<p>Drink Dispense</p> 	<p>“ERROR! LEFT MIXER” or “ERROR! RIGHT MIXER”</p>	<p>Mixer 1 or 2 out of sync</p>	<p>Possible power glitch and UI board reset while Mixer in dispense state OR SRB reset and UI expects Mixer to be in some other state.</p>	<p>“Blender in unexpected State” shall be displayed for the Left/right blender status message.</p>	<p>Turn off power switch for 10 seconds turn on. Check Blender board, and SRB firmware. Check dip switches for proper position See “Blender Control Board” on page 279.</p>
<p>Drink Dispense</p> 	<p>Service required, Please Contact your Local Multiplex Service Provider</p>	<p>Maintenance Required</p>	<p>1 year or 36,000 cycles have been reached.</p>	<p>Service required, Please Contact your Local Multiplex Service Provider is displayed.</p>	<p>Contact Manitowoc for proper procedure.</p>

This Page Intentionally Left Blank

Troubleshooting

Control System

WILL NOT RUN DIAGNOSTICS



Warning

High (line) voltage is present when the back panel is removed.

1. Verify primary voltage is supplied at the plug.
2. Reboot by disconnecting and reconnecting the main power supply.
3. Verify ON/OFF rocker switch functions properly and supplies line voltage to power relay coil (T1 - T0).
4. Verify power relay contacts are closed (T2 -T4 and T6 - T8).
5. Verify line voltage is present at the 24VDC power supply primary - CN2.
6. Verify 24VDC is present at the power supply secondary - CN1.
7. Verify in-line 4 amp fuse on 24 VDC supply is closed.
8. Verify 24 VDC is present at SRB board MTA2 (J35) connector. Disconnect and reconnect wiring to verify connection
9. Duct fan, cabinet refrigeration or ice machine operating?
 - No - Replace SRB board.
 - Yes - Go to next step.
10. User Interface (UI) energized?
 - No - Inspect wiring, disconnect and reconnect wiring to verify connection, replace UI.
 - Yes - Go to next step.
11. Does UI progress through screens?
 - No - Reload Firmware and Recipe File "Firmware Update Procedure" on page 187
 - Yes - Go to next step.

12. Do any components energize during the drink making sequence?
 - No - Replace SRB board.
 - Yes - Troubleshoot non functional component. If blender is non functional proceed to Blender Motor section.

NOTE: On double spindle models, both blender assemblies will require testing.

13. 24 VDC on Motor Controller Board MTA2 (J1)?
 - No - Replace wire.
 - Yes - Go to next step.
14. Home position switch closed on motor controller circuit board Home SWT (J13)?
15. Door switch circuit closed on motor controller circuit board Door SWT (J9)?
16. Door switch circuit closed and supplying 24 VDC to coil on DPDT relay?
17. Blade DPDT relay contacts closed?
18. Blade motor running?
 - No - Test capacitor - Replace blade motor
 - Yes - Go to next step.
19. Step motor operates?
 - No - Replace Motor

Beverage System

BEVERAGE SYSTEM DIAGNOSTICS

1. Is line voltage is supplied?
2. Is Air/CO₂ supply pressure is between 50 and 80 psi and regulated to 35 psi? Refer to “How to Adjust Air/CO₂ Pressure” on page 259.
3. Is water supply pressure is between 30 and 90 psi and regulated to 30 psi?
4. Is product is inserted in cabinet and correctly connected to adapter/tubing?
5. Is ice is available?
6. Has a recipe has been developed in MenuConnect and transferred to the control board with a USB drive? Refer to “Recipe Loading Procedure” on page 190
7. Do any recipes dispense properly?
 - No - Refer to “Will Not Run Diagnostics” on page 219.
 - Yes - Determine malfunctioning recipe slot number and continue with next step.

NOTE: Refer to “Procedure to Clear Blocked Line” on page 252 to initiate a prime procedure and assure the component is energized during the test time period.

8. 24 VDC to syrup solenoid valve?
 - No - Inspect wiring, disconnect and reconnect wiring to verify connection, replace SRB board.
 - Yes - Go to next step.
9. Air/CO₂ supplied to product pump?
 - No - Replace syrup solenoid valve.
 - Yes - Refer to “Procedure to Clear Blocked Line” on page 252. If the line is not blocked and the pump does not function replace the product pump.

PROCEDURE TO CLEAR BLOCKED LINE

NOTE: Verify product is available and properly connected before performing this procedure.

1. Fill a squirt bottle with very warm water.
2. Remove product bin.
3. Connect squirt bottle with vinyl tubing to product tube inlet.
4. Select the Inventory icon from the Main Menu.

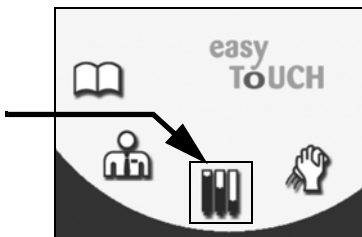

5. Select the product with the blocked line.

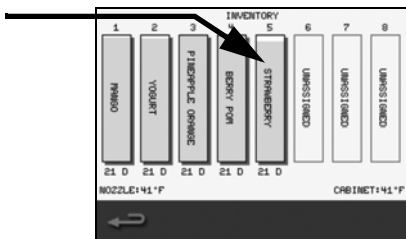

6. Select the green check twice without following the product replacement instructions.

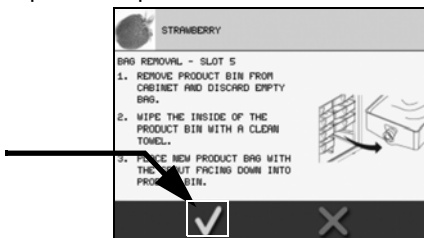

Continued on next page ...

7. Select PRIME FLAVOR.

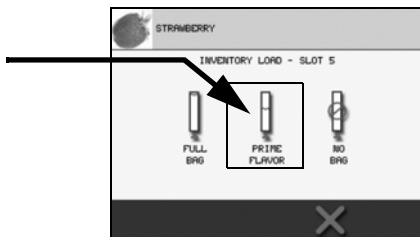

8. Place a cup under dispenser.

9. Select HOLD TO PRIME icon while squeezing the squirt bottle. Watch for product to enter the cup.

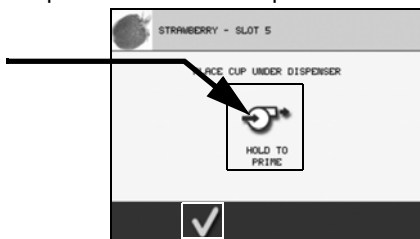

10. Repeat until valve clears, product and/or water enters the cup.

11. Disconnect squirt bottle with vinyl tubing. Insert product bin back into unit.

12. Select HOLD TO PRIME icon until only product flows into cup.

13. Select green check when finished to return to the product inventory screen.

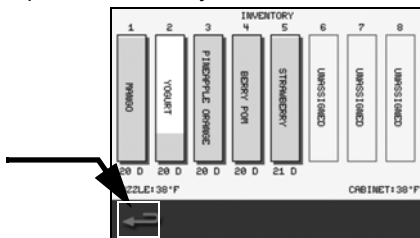

14. Press the Return Arrow to return to the Main Menu.

Ice System

Ask these questions before beginning service:

- When does the ice system malfunction? (Normal operation, after a cleaning cycle, etc.)
- When do you notice low ice production? (One day a week, every day, etc.)
- Can you describe exactly what the ice system seems to be doing?
- Has anyone been working on the ice machine? (Has anyone turned the two switches off on the back of the unit.)
- Is there any reason why incoming water pressure might rise or drop substantially?

INSTALLATION/VISUAL INSPECTION CHECKLIST

Possible Problem List	Corrective Action List
Condenser filter is dirty.	Clean the condenser filter.
Airflow through top half of the machine are restricted.	150mm gap on either side of unit is needed.
Water filtration is plugged (if used).	Install a new water filter.

WATER SYSTEM CHECKLIST

A water-related problem could cause component misdiagnosis. Water system problems must be identified and eliminated prior to replacing other components.

Possible Problem List	Corrective Action List
Water supply pressure not between 30 and 80 psig.	Check water supply pressure.
BiC Water supply regulator inn back room should be set at 60 psig.	Check regulator setting and adjust to 60psig pressure.
Water regulator on the back of unit should be set to 35psig.	Adjust regulator to 35psig
Incoming water temperature is not between 45°F (1.7°C) and 90°F (32.2°C).	If too hot, check the hot water line check valves in other store equipment.
Water filtration is plugged (if used).	Install a new water filter.
Hoses, fittings, etc., are leaking water.	Repair/replace as needed.
Water float valve is stuck open or closed.	Clean/replace as needed.
Water probes in header tank are not detecting water.	Short probes to check. Clean probes.
Water probes in header tank are not detecting water.	Short probe cable out at board connection. Replace cable if needed
Dump valve on header tank drain is leaking.	Clean dump valve.

ICE PRODUCTION & QUALITY CHECK

QUALITY CHECK

Ice production will vary with ambient and water temperatures.

Higher incoming water temperature results in lower ice production quantity.

Lower water temperature results in higher ice quantity.

ICE PRODUCTION CHECK

1. Empty the ice from the unit by starting Zone 3 cleaning which dumps ice for 4 minutes.
2. Remove the ice bin lid, remove the ice dispense drive shaft / agitator.
3. Run the ice machine a minimum of 10 minutes to allow the system to stabilize.
4. Measure the air temperature entering the condenser and the water temperature entering the unit, (with insulated probe.)
5. Weigh a dry non-perforated container that will fit in the ice bin to catch the ice.
6. Catch the ice in container for 7 minutes and 12 seconds (approximately 1kg) or for more accuracy 14 minutes and 24 seconds (approx.2).
7. Weigh the container and ice, and then deduct the weight of the container.
8. Determine the 24-hour ice production capacity.
 - 7 minutes 12 seconds
 - Multiply the total ice weight by 200.
 - 14 minutes 24 seconds
 - Multiply the total ice weight by 100.

EXAMPLE:

1. Collected ice for 7 minutes 12 seconds.
2. Total weight (minus container) = 0.95kg.
3. 0.95kg. x 200 = 190kg of ice every 24 hours
4. Compare the capacity to the 24-hour ice production chart for the conditions being tested.
5. Ice production checks that are within 10% of the charted capacity are considered normal due to variances. Actual temperatures will seldom match the chart exactly.

Ice Production Chart

Acceptable incoming water temperature range is 40°F (4°C) to 90°F (32°C). Optimum Range is 45°F(7°C) to 50°F(10°C) (*Target 50°F(10°C), results based on ARI capacity testing @ 70°F(21°C) air temperature*).

24 Hour Ice Production lbs / kg			
Air Temp Entering Condenser °F / °C	Water Temperature °F/°C		
	50/10	70/20	90/32
50/10	419 (190 kg)	390 (177 kg)	359 (163 kg)
70/21	410 (186 kg)	381 (173 kg)	353 (160 kg)
80/27	395 (179 kg)	366 (166 kg)	340 (154 kg)
90/32	379 (172 kg)	353 (160 kg)	326 (148 kg)
100/38	362 (164 kg)	335 (152 kg)	311 (141 kg)
110/43	344 (156 kg)	320 (145 kg)	295 (134 kg)

NOTE: If chilled water is being used, depending on the incoming Water Temp, the use of a chiller can drive an increase in ice capacity between 50 lbs (23 kg) and 125 lbs (57 kg) per day.

MB-8-1PP ICE MACHINE ELECTRICAL TROUBLESHOOTING FLOWCHART

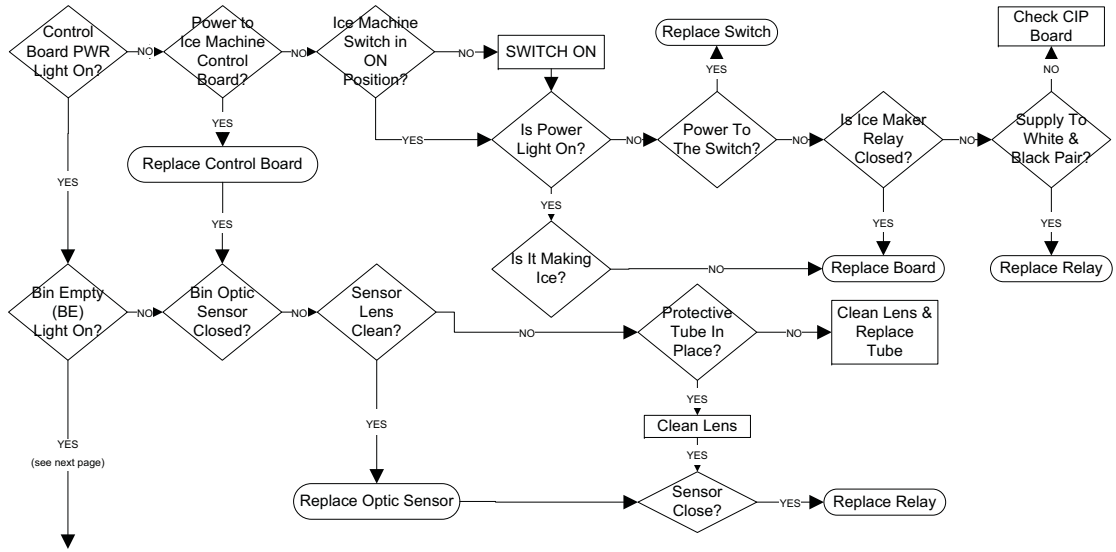

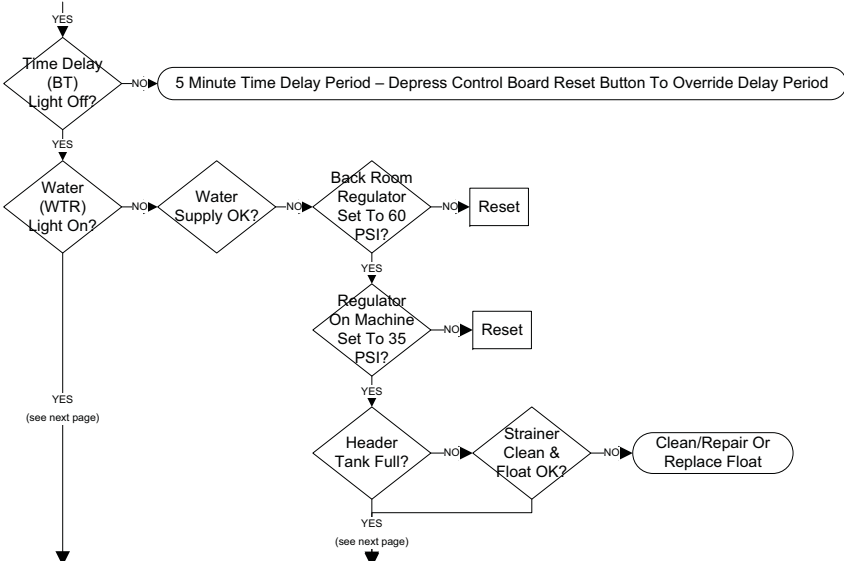

YES
(see next page)

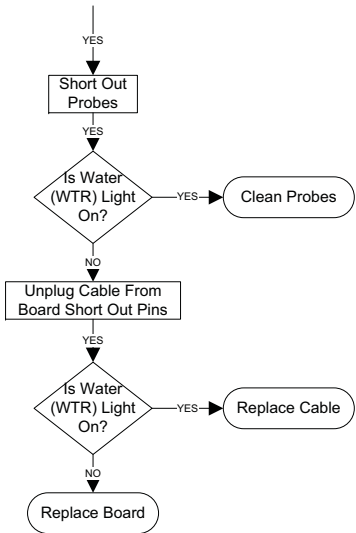

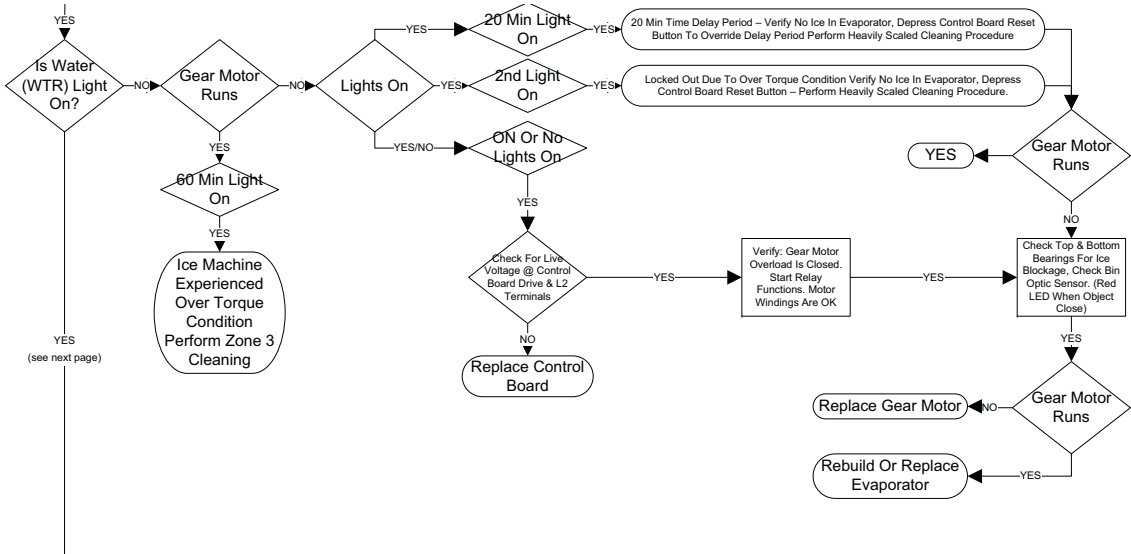

YES
(see next page)

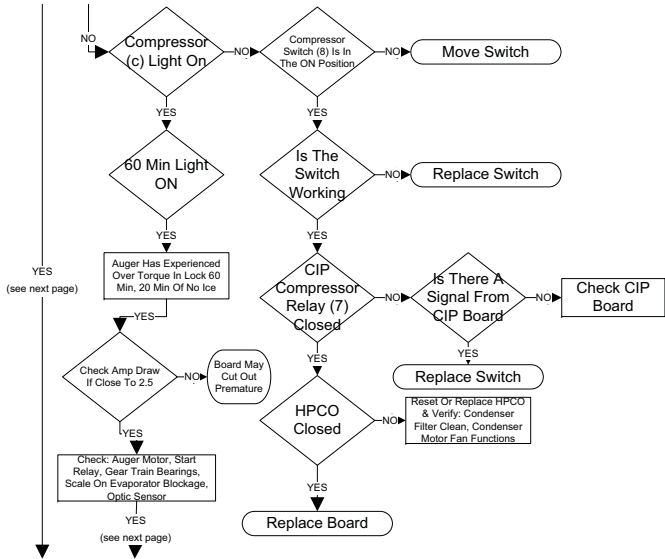

YES
(see next page)

YES
(see next page)

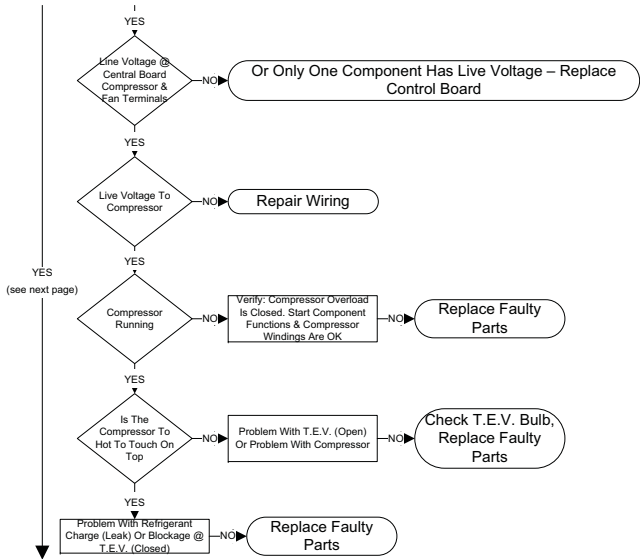

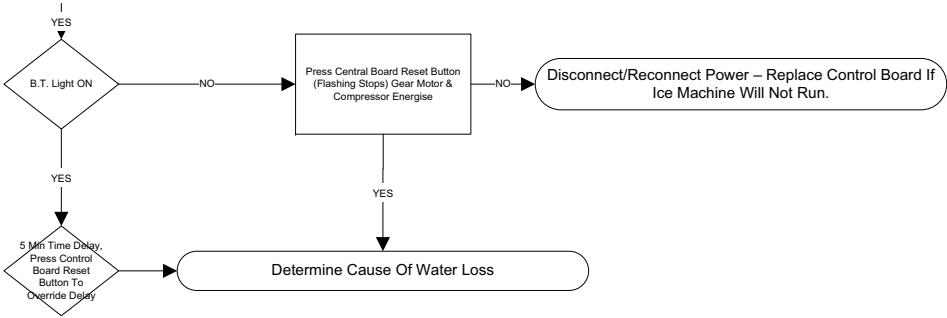

Refrigerated Cabinet

Refrigerated Cabinet Flowchart - R290 Refrigerant

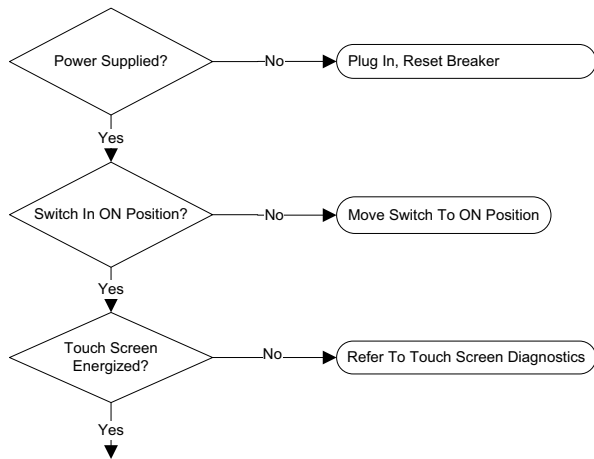

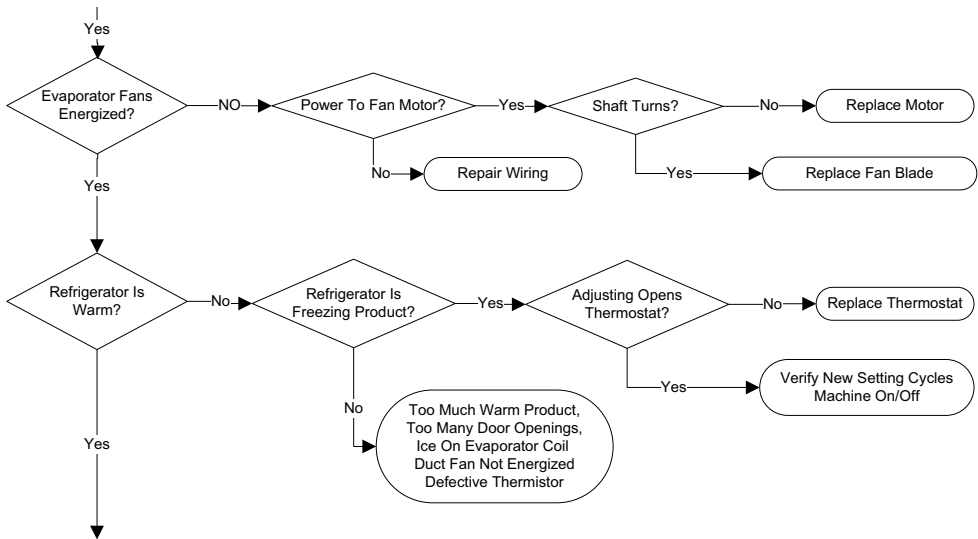

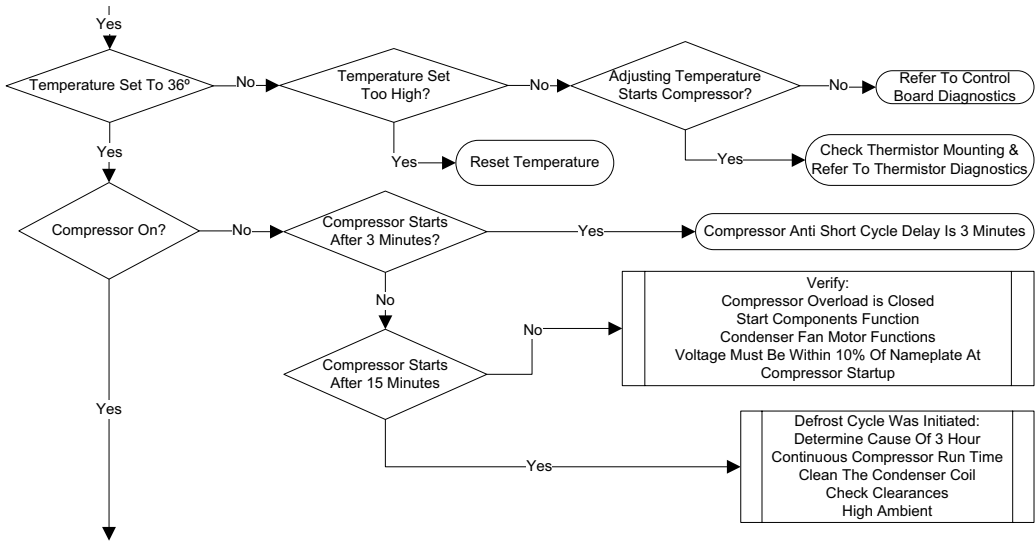

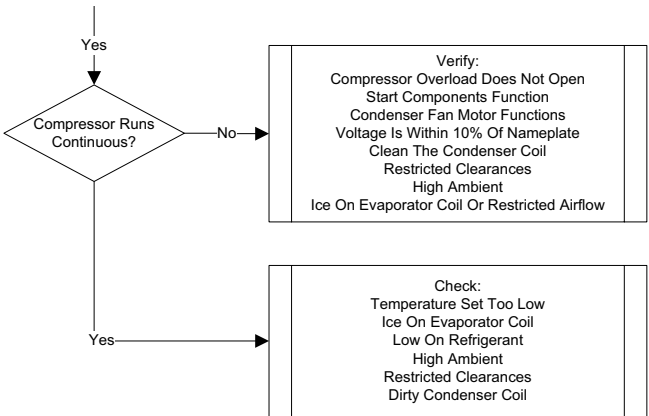

REACH-IN TEMPERATURE OUT OF RANGE

Check Refrigeration System & Door Seal

Temperature in reach-in unit above or below acceptable limits.

Above temperature limit:

- Verify Cabinet temperature is above 5.5C/42F.
- Compare temps on IU.
- Check duct fan (1) for proper operation.
- Check evaporator fans (3) for proper operation.

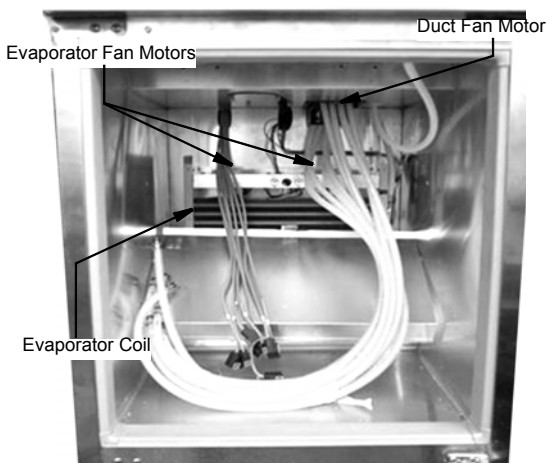

- Verify door is closed and door gasket is in place.
- If all above are within Spec's refer to Refrigeration diagnostics. See "Refrigeration System Diagnostics" on page 244.

Below temperature limit:

- Compare temps on IU
- Check temperature set point.

- Using the touch screen, go to the Managers Menu on the Main Screen, click on the Managers Icon.



- Type in password (default is "A") and press the green check mark.

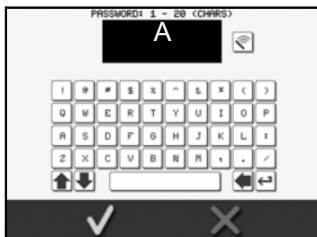

- Select the down arrow.

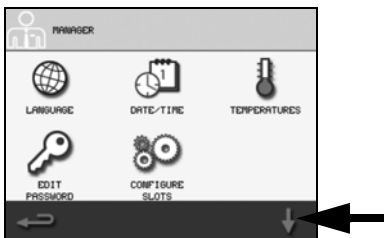

- Select the Service Icon.

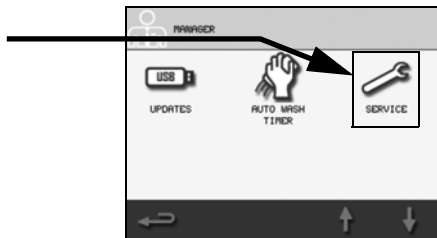

- Type in Password (default is “A”) and press the green check mark.



- Select the down arrow.

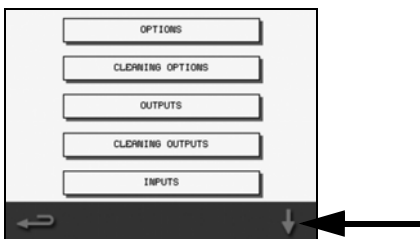

- Select Cabinet Settings

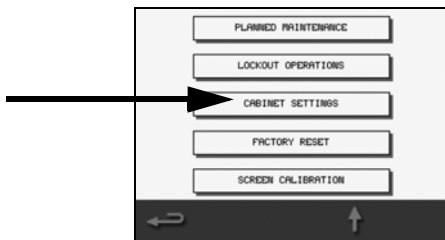

- Read Temperatures

CABINET SETTINGS		
SETTING	VALUE	UNITS
SET POINT	36.0	*F
DIFFERENTIAL	4.0	*F
RIN OFF TIME	3	MINUTES
DEFROST RUN TIME	100	MINUTES
DEFROST TEMPERATURE	43.0	*F
DEFROST TIME	15	MINUTES
DEFROST INITIAL TEMPERATURE	5.0	*F
DEFAULT ON TIME	12	MINUTES

Check Thermistor

SPECIFICATIONS

- 5,000 Ohms \pm 2% at 25°C (77°F)
- 16,330 Ohms \pm 2% at 0°C (32°F)

CHECK PROCEDURE

NOTE: Use a multimeter to check operation.

1. Reboot machine by moving rocker switch OFF/ON.
2. Inspect for correct wiring.
3. Isolate by disconnecting the wiring connectors on SRB J32 Temp Drive 3 / Cabinet Probe 1.
4. Check continuity across the terminals with an ohm meter.
 - Resistance = Thermistor is good
 - Open (OL) = Replace thermistor

NOTE: These thermistors are identical. Swapping the thermistor connections at the IO board can be used for diagnostics. See "Temperature/Resistance Chart" on page 298.

Check compressor relay on SRB

With power disconnected, check the compressor relay that is mounted on the SRB. The compressor relay is the largest relay on the SRB and has two terminals exposed that can be checked for continuity. The exposed terminals are the Common (C) and the Normally Open (NO). If there is continuity between the terminals with power disconnected to the unit, the relay contacts are defective and the SRB should be replaced.

HIGH PRODUCT TEMPERATURE

Check Duct Cooling Fan

Product temperature is greater than 42°F.

- Verify the door was not left open or warm product was added.
- Reboot machine by moving toggle switch off/on.
- Verify duct fan is operating.
- Allow machine to run for 15 minutes then prime each product.
- If fault remains check duct temperature with a digital thermometer to determine if refrigeration or thermistor diagnostics need to be performed.

Refrigeration System Diagnostics

ANALYZING DISCHARGE PRESSURE OR TEMPERATURE

1. Determine the ice machine operating conditions:
 - Air temperature entering condenser
 - Air temperature around ice machine
 - Water temperature entering water reservoir
2. Refer to 24-Hour Ice Production/Refrigeration Pressure/Temperature Chart for ice machine being checked.

Use the operating conditions determined in step 1 to find the published normal discharge pressure/temperature and compare to actual measurements.

3. Measure the actual discharge pressure/temperature.
4. Compare the measurements (step 3) with the published pressure/temperature (step 2).

Measurements will fall within the published range on normally operating ice machine's.

Discharge Pressure/Temperature High Checklist

Problem	Cause
Improper installation	Refer to Installation procedures.
Restricted condenser air flow	Dirty air filter High inlet air temperature Condenser discharge air recirculation Dirty condenser fins Defective fan motor Defective fan cycle control
Improper refrigerant charge	Overcharged Non-condensable in system Wrong type of refrigerant
Other	Non-OEM components in system High side refrigerant line/component restricted (before mid-condenser)

Discharge Pressure/Temperature Low Checklist

Problem	Cause
Improper installation	Refer to Installation procedures.
Improper refrigerant charge	Undercharged Wrong type of refrigerant
Other	Low ambient temperature High side refrigerant lines/component restricted (before mid-condenser) Suction pressure is too low and affecting discharge pressure. (Refer to "Suction Pressure/Temperature Low Checklist.") No water or insufficient pressure Starving expansion valve Defective compressor Moisture in refrigeration system Defective fan cycle control

NOTE: Do not limit your diagnosis to only the items listed in the checklists.

ANALYZING SUCTION PRESSURE OR TEMPERATURE

NOTE: Analyze discharge pressure/temperature before analyzing suction pressure/temperature. High or low discharge pressure/temperature may be causing high or low suction pressure/temperature.

Suction Pressure/Temperature High Checklist

Problem	Cause
Improper installation	Refer to Installation procedures.
Discharge pressure	Discharge pressure/temperature is too high and is affecting suction pressure/temperature. Refer to "Discharge Pressure/temperature High Checklist."
Improper refrigerant charge	Overcharged Wrong type of refrigerant Non condensable in system
Other	Non-OEM components in system TXV flooding (check bulb mounting and insulation). Defective compressor

Suction Pressure/Temperature Low Checklist

Problem	Cause
Improper installation	Refer to Installation procedures.
Discharge pressure/temperature	Discharge pressure/temperature is too low and is affecting suction pressure/temperature. Refer to "Discharge Pressure/Temperature Low Checklist."
Improper refrigerant charge	Undercharged Wrong type of refrigerant
Other	Non-Manitowoc components in system Restricted/plugged liquid line drier Restricted/plugged tubing in suction side of refrigeration system Expansion valve starving No water or insufficient pressure Moisture in refrigeration system Dirty Evaporator Defective Fan Cycle Control
NOTE: Do not limit your diagnosis to only the items listed in the checklists	

ANALYZING DISCHARGE PRESSURE OR TEMPERATURE

1. Determine the ice machine operating conditions:
 - Air temperature entering condenser
 - Air temperature around ice machine
 - Water temperature entering water reservoir
2. Refer to 24-Hour Ice Production/Refrigeration Pressure/Temperature Chart for ice machine being checked.

Use the operating conditions determined in step 1 to find the published normal discharge pressure/temperature and compare to actual measurements.

3. Measure the actual discharge pressure/temperature.
4. Compare the measurements (step 3) with the published pressure/temperature (step 2).

Measurements will fall within the published range on normally operating ice machine's.

Discharge Pressure/Temperature High Checklist

Problem	Cause
Improper installation	Refer to Installation procedures.
Restricted condenser air flow	Dirty air filter High inlet air temperature Condenser discharge air recirculation Dirty condenser fins Defective fan motor Defective fan cycle control
Improper refrigerant charge	Overcharged Non-condensable in system Wrong type of refrigerant
Other	Non-OEM components in system High side refrigerant line/component restricted (before mid-condenser)

Discharge Pressure/Temperature Low Checklist

Problem	Cause
Improper installation	Refer to Installation procedures.
Improper refrigerant charge	Undercharged Wrong type of refrigerant
Other	Low ambient temperature High side refrigerant lines/component restricted (before mid-condenser) Suction pressure is too low and affecting discharge pressure. (Refer to "Suction Pressure/Temperature Low Checklist.") No water or insufficient pressure Starving expansion valve Defective compressor Moisture in refrigeration system Defective fan cycle control

NOTE: Do not limit your diagnosis to only the items listed in the checklists.

ANALYZING SUCTION PRESSURE OR TEMPERATURE

NOTE: Analyze discharge pressure/temperature before analyzing suction pressure/temperature. High or low discharge pressure/temperature may be causing high or low suction pressure/temperature.

Suction Pressure High Checklist

Problem	Cause
Improper installation	Refer to Installation procedures.
Discharge pressure	Discharge pressure/temperature is too high and is affecting suction pressure/temperature. Refer to "Discharge Pressure/temperature High Checklist."
Improper refrigerant charge	Overcharged Wrong type of refrigerant Non condensable in system
Other	Non-OEM components in system TXV flooding (check bulb mounting and insulation). Defective compressor

Suction Pressure/Temperature Low Checklist

Problem	Cause
Improper installation	Refer to Installation procedures.
Discharge pressure/temperature	Discharge pressure/temperature is too low and is affecting suction pressure/temperature. Refer to "Discharge Pressure/Temperature Low Checklist."
Improper refrigerant charge	Undercharged Wrong type of refrigerant
Other	Non-Manitowoc components in system Restricted/plugged liquid line drier Restricted/plugged tubing in suction side of refrigeration system Expansion valve starving No water or insufficient pressure Moisture in refrigeration system Dirty Evaporator Defective Fan Cycle Control
NOTE: Do not limit your diagnosis to only the items listed in the checklists	

Procedure to Clear Blocked Line

NOTE: Verify product is available and properly connected before performing this procedure.

1. Fill a squirt bottle with very warm water.
2. Remove product bin.
3. Connect squirt bottle with vinyl tubing to product tube inlet.
4. Select the Inventory icon from the Main Menu.

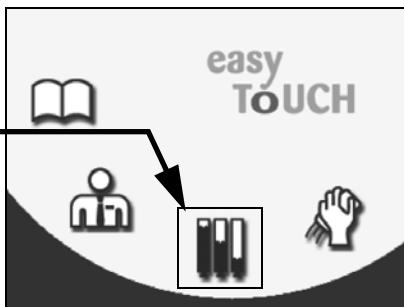

5. Select the product with the blocked line.

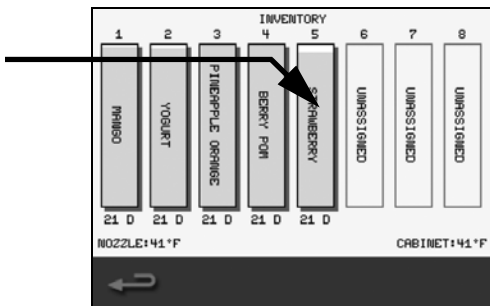

6. Select the green check twice without following the product replacement instructions.

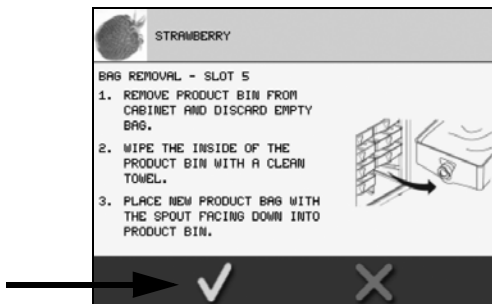

7. Select PRIME FLAVOR.

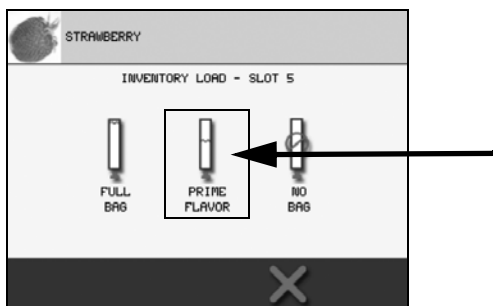

8. Place a cup under dispenser.
9. Select HOLD TO PRIME icon while squeezing the squirt bottle. Watch for product to enter the cup.

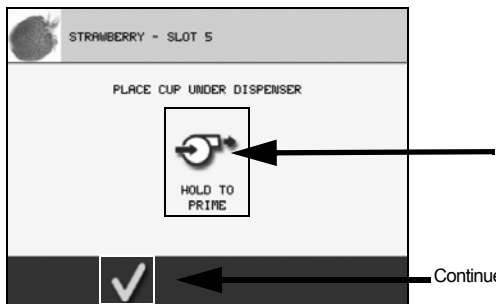

- Repeat until valve clears, product and/or water enters the cup.
- Disconnect squirt bottle with vinyl tubing. Insert product bin back into unit.
- Select HOLD TO PRIME icon until only product flows into cup.
- Select green check when finished to return to the product inventory screen.

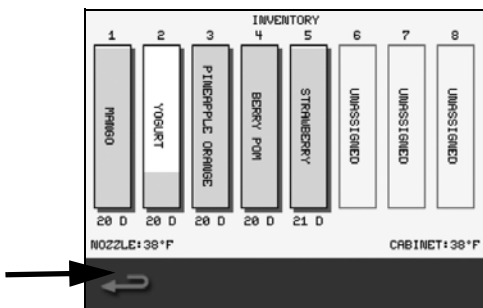

- Press the Return Arrow to return to the Main Menu.

How to Check Air/CO2 Pressure

1. Using the touch screen, go to the Prime Screen accessed through the Inventory Icon from the Main Menu.

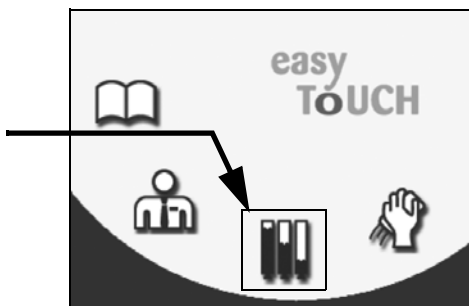

2. On the inventory screen select any assigned product slot.

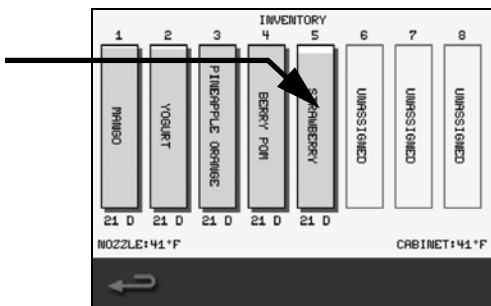

3. Select the green check twice without following the product replacement instructions.

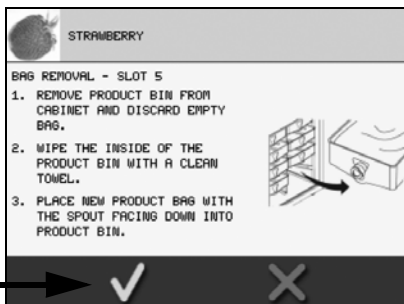

4. Select "PRIME FLAVOR".

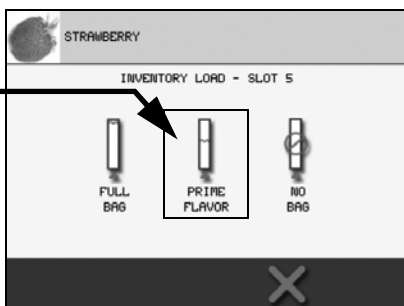

5. Place a cup under dispenser.

6. Locate the Air/CO2 regulator on the left side of the unit.

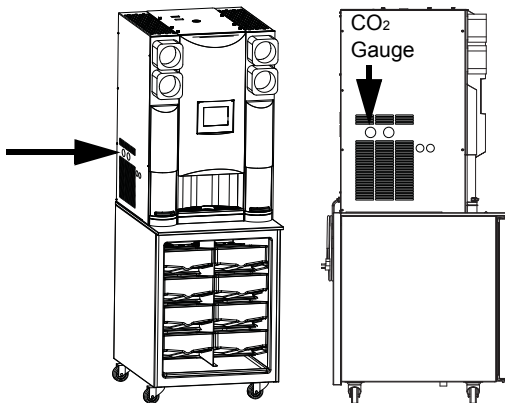

7. Press and hold the "HOLD TO PRIME" icon while checking the CO2 pressure reading on the regulator on the left side of the unit.

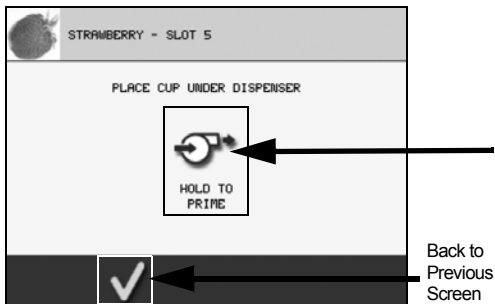

8. The regulator will decrease to a stable pressure while the product is priming and then rise back to a higher pressure when the prime button is released.

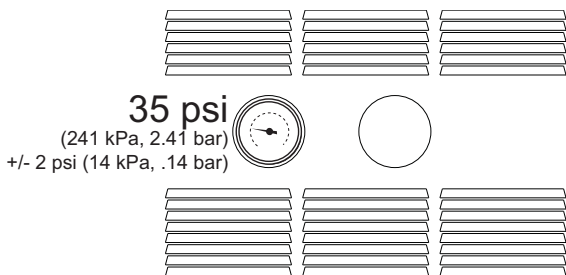

9. The regulator should maintain 35 psi (241 kPa, 2.41 bar) +/- 2 psi (14 kPa, .14 bar) under flowing conditions.
10. If the Air/CO2 regulator fails to maintain this pressure during flowing conditions remove panels and adjust under flowing conditions. See “How to Adjust Air/CO2 Pressure” on page 259.

NOTE: To save product Air/CO2 pressure can be checked during Zone 2 Cleaning or at any time product pumps are in use.

HOW TO ADJUST AIR/CO₂ PRESSURE

1. Using the touch screen, go to the Managers Menu on the Main Screen, click on the Managers Icon.

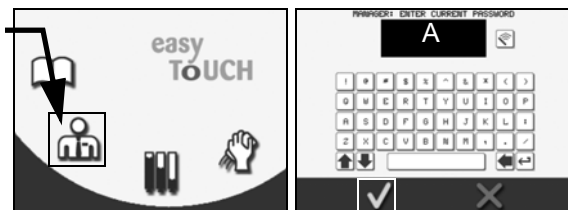

2. Type in Password (Default password is "A") and click the green check mark.
3. Select the down arrow.



4. Select the Service icon.

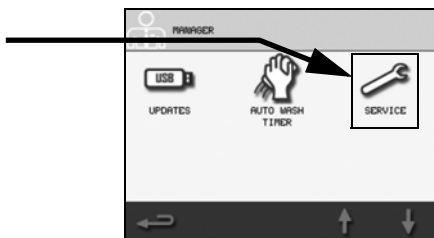

5. Type in Password (Default password is “A”) and click the green check mark.

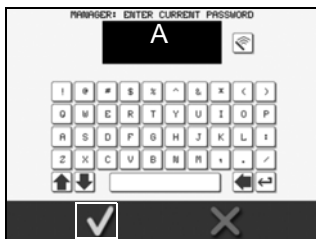

6. Select OUTPUTS.

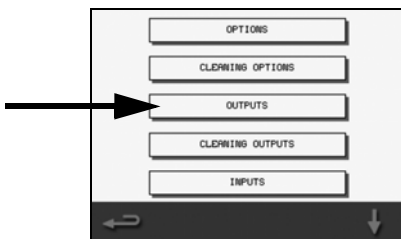

7. First check in refrigerated cabinet to confirm and open slot. Identify the open slot number (Flavor Solenoid #x) on the screen

OUTPUTS	
COMPONENT	CURRENT STATE
FLAVOR SOLENOID 1:	OFF
FLAVOR SOLENOID 2:	OFF
FLAVOR SOLENOID 3:	OFF
FLAVOR SOLENOID 4:	OFF
FLAVOR SOLENOID 5:	OFF
FLAVOR SOLENOID 6:	OFF
FLAVOR SOLENOID 7:	OFF
FLAVOR SOLENOID 8:	OFF

↩ ↓

8. Locate the Air/CO2 regulator on the left side of the unit.

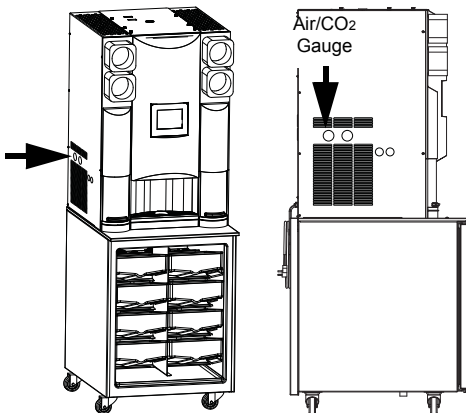

9. In the green box select the Flavor Solenoid previously identified

OUTPUTS	
COMPONENT	CURRENT STATE
FLAVOR SOLENOID 1:	OFF
FLAVOR SOLENOID 2:	OFF
FLAVOR SOLENOID 3:	OFF
FLAVOR SOLENOID 4:	OFF
FLAVOR SOLENOID 5:	OFF
FLAVOR SOLENOID 6:	OFF
FLAVOR SOLENOID 7:	OFF
FLAVOR SOLENOID 8:	ON



10. The regulator will decrease to a stable pressure while the product is priming and then rise back to a higher pressure when the prime button is released

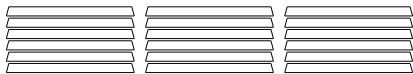

35 psi
(241 kPa, 2.41 bar)
+/- 2 psi (14 kPa, .14 bar)



11. The regulator should maintain 35 psi (241 kPa, 2.41 bar) +/- 2 psi (14 kPa, .14 bar) under flowing conditions.
12. If the Air/CO2 regulator fails to maintain this pressure during flowing conditions remove panels and adjust under flowing conditions.

How to Check Plain Water Pressure

1. Using the touch screen, gain access to the Blend Chamber Rinse Button(s) located at the bottom of either the Drink or Flavor Selection screen.

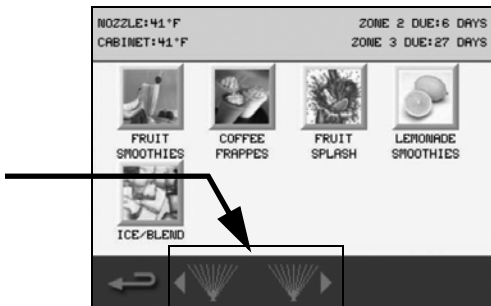
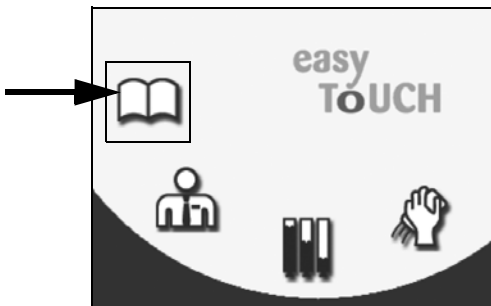

Drink Selection Screen

2. Activate a rinse cycle by touching the right or left rinse button while reading the plain water regulator on the left side of the unit.

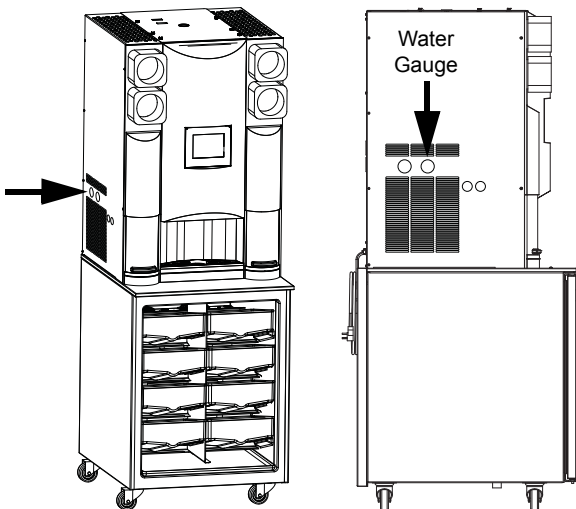

3. The regulator will decrease to a stable pressure while the water is flowing and then rise back to a higher pressure once the rinse completes.



35 psi
(241 kPa, 2.41 bar)
+/- 2 psi (14 kPa, .14 bar)

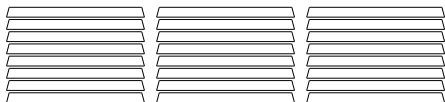

4. The regulator should maintain 35 psi (241 kPa, 2.41 bar) +/- 2 psi (14 kPa, .14 bar) under flowing conditions.
5. If the plain water regulator fails to maintain this pressure during flowing conditions remove side panels and adjust under flowing conditions.

Component Check Procedures

Control System

ON/OFF ROCKER SWITCH

Location

The ON/OFF switch is located on the left side of the unit when viewing from the front.

Function

Supplies power to the Blender components. Turns unit ON and OFF.

Specification

This is a rocker switch with a double pole, double throw switch.

Check Procedure

To check the switch, unplug the power supply to the equipment.

1. Check for loose or broken wires at that terminals
2. Remove the wires (marked #14) and with your ohm meter check continuity between (2) two terminals in the ON position.

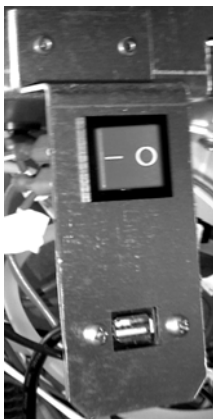

3. There should be continuity.
4. If no continuity is read, replace the switch
5. Press the switch to the OFF Position. (O)
6. Check continuity between the (2) two terminals, there should be no continuity between the terminals.
7. If continuity is read, replace the switch.

POWER RELAY

Location

Located behind the left hand side panel.

Function

Removes full load amperage of components and motors from ON/OFF rocker switch.

Specification

Double Pole Single Throw (DPST), 220VAC coil, average coil resistance 21KOhms, Contact rating - 30A @ 120VAC. When energized, contacts close and allow power to flow to SRB board (J9 & J10), Power Supply (CN1), and Evaporator fans.

Check Procedure

There is a small black manual push button on the relay body to allow testing of the contacts with the unit de-energized. Disconnect the wiring to the contacts and check resistance while pressing the test button. The resistance across the contacts should be less than 1.0 ohms.



If the relay is energized and contacts are closed the button will be pulled in, flush with the body of the relay.

Power Relay Coil Test Procedure

1. Check the coil using an ohm meter, the coil should have a nominal resistance reading. If no reading the coil is open and the Power Relay should be replaced.
 2. With the ON/OFF rocker switch in the "ON" position, check for line voltage at relay coil
- Line voltage present - Contacts should be closed, if not replace the relay.
 - No line voltage present - Refer to ON/OFF rocker switch check procedure.

POWER SUPPLY

Location

The 24VDC power supply is located behind the left side panel.

Function

Reduces and converts voltage for use on the control circuit.

Specifications

Steps down voltage from:

90 - 264/50-60/1 VAC to 24 VDC 8.4 A

Check Procedure

1. Inspect for correct wiring.
2. Check for line voltage at transformer primary CN1.
 - No line voltage present - Refer to power relay and toggle switch check procedures.
 - Line voltage present - Continue diagnostics
3. Check voltage at transformer secondary CN3.
 - 24VDC present - Transformer is OK.
 - 24VDC is not present - Isolate secondary wiring and check for 24VDC.
 - 24VDC present - Repair wiring or replace effected component(s).
 - 24VDC is not present - Replace Power Supply.
 - One LED light - constant on to indicate power is applied - located at the lower left corner ofCN3.

POWER SUPPLY BOARD

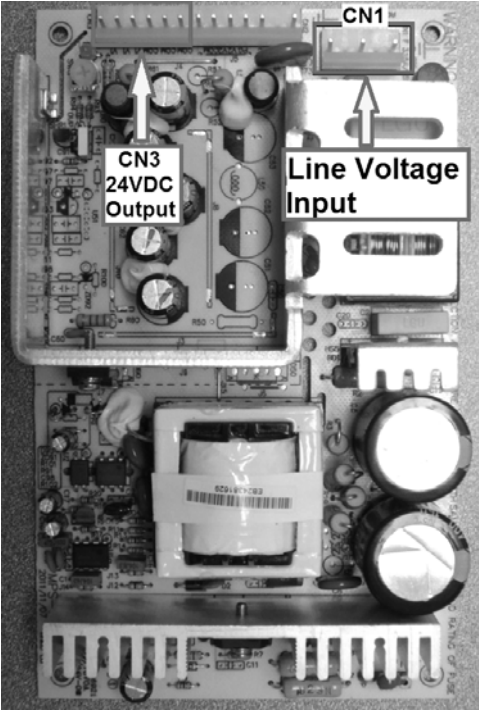

UI (USER INTERFACE - TOUCHSCREEN)

Location

The User Interface is located on the upper front section of the BIC unit.

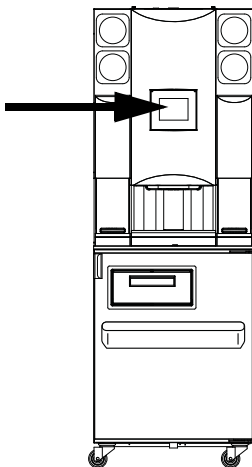

Function

The UI provides a method for the user to instruct the machine to a specific task, such as making drinks and providing cleaning instructions. The UI receives inputs from the user via screen touches and executes the function based on the current firmware.

The UI processes inputs and sends signals to the SRB relay board to energize and de-energize components. The UI is the main control board of the BIC unit.

Specifications

The UI assembly is made up of an integrated control board along with a touchscreen panel. A Modbus communication cable provides the path of communication as well as the power supply for the UI. The UI is also equipped with a USB port for uploading firmware to each of the system boards and the customer's recipe file

Check Procedure

1. Reboot machine by moving toggle switch off/on or disconnecting and reconnecting main power supply.
2. With the power off, remove the UI from the front of the unit. Verify the communication cable connection is secure by removing and reinserting the connector. Safely position the UI assembly, power up and check display.
3. With the power off, remove the UI from the front of the unit but do not disconnect the cables. With the UI safely positioned power up the unit and check the LED indicator lights on the integrated control board of the UI assembly. There are a total of 5 LED's on the UI. See "UI (User Interface)" on page 274.
 - 1.Power
 - 2.Heartbeat/Run LED
 - 3.P-BUS: pulses represent transactions/traffic
 - 4.C-BUS: pulses represent transactions/traffic
 - 5.USB-Link: On when USB device is present
4. If no LED lights are illuminated turn the power off and disconnect the power supply cord. Inspect the ribbon cables and power supply connection between the integrated control board and touchscreen panel. Insure connections are secure, safely position the UI assembly and connect the power cord and power up the unit. Again check the LED's for activity.
5. If no LED lights are illuminated turn the power off and disconnect the power supply cord. Remove the lid holder support rail system, the top and left side panels. Check the UI communication cable connection at the SRB board - J6. Verify the connection is secure by removing and reinserting the connector.

6. With the power supply cord disconnected, disconnect the 24VDC power input from the SRB board at J35. Connect the leads of your multimeter to the 24VDC connector and properly set the meter to test for the anticipated DC voltage. Power the unit back up and check for 24VDC supply
7. If 24VDC power is verified at the connector, turn the power off and disconnect the power supply cord. Disconnect the 24VDC connector from the multimeter and reconnect to the SRB board at J35. Power up the unit and check the UI LED's. If no LED activity - Replace the UI.
8. If 24VDC power is not present, power down and check the inline 4 amp fuse between the SRB board and the 24VDC power supply also located behind the left side panel. If the fuse checks open it will need to be replaced.
9. If the fuse checks closed, connect your multimeter leads to the output connection of the 24VDC power supply - CN3, (T1 - T3 are +24VDC / T4 - T8 are -24VDC) Properly set the meter to test the anticipated DC voltage and power up the unit.
10. If 24VDC power is not present, power down the unit and refer to the test procedures for the 24VDC Power Supply. If the UI is not operational after the 24VDC power is restored, repeat the above test

UI (USER INTERFACE)



SRB BOARD

Location

The SRB board is located behind the left side panel.

Function

The SRB board receives inputs from various controls and outputs power as needed to various components at specific times based on the current firmware and activity of components. The SRB board is the central hub of operations. Communications and power distribution all connect through the SRB board.

Specifications

The SRB board receives and distributes 230VAC, 24VDC, & Modbus communication capabilities to various components. The SRB functions are controlled by the onboard firmware in conjunction with signal inputs from the UI, the blender boards, thermistor probes, ice wheel reed switch, and the ice bin level sensor. SRB firmware can be uploaded via the USB port near the power switch on the left side of the unit.

Check Procedure

The SRB board can be verified as good or deemed to be defective based on input and output test.

1. Using the UI, go to the Output screen - (Managers Menu> Service Menu> Outputs).
2. From the OUTPUTS screen select the load to be tested from the list.

OUTPUTS	
COMPONENT	CURRENT STATE
FLAVOR SOLENOID 1:	OFF
FLAVOR SOLENOID 2:	OFF
FLAVOR SOLENOID 3:	OFF
FLAVOR SOLENOID 4:	OFF
FLAVOR SOLENOID 5:	OFF
FLAVOR SOLENOID 6:	OFF
FLAVOR SOLENOID 7:	OFF
FLAVOR SOLENOID 8:	OFF

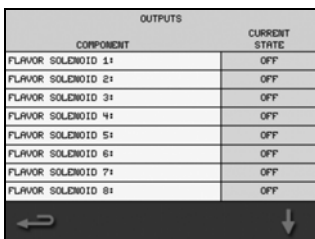

3. The current state of the load will normally be "OFF" and touching the screen in the green area will turn the load "ON" - color changes to red, text changes to "ON".

4. If the selected load does not come on this could indicate an issue with the selected component, the SRB board, or a voltage supply issue.
5. Select a different load that requires the same power - another line voltage load or another low voltage load.
6. If no line voltage loads operate verify the line voltage, 230VAC, is present at J9 (N) & J10 (L1).
7. If incoming line voltage is not present at J9 & J10 verify the wiring is intact and connected to the Power Relay. Follow Power Relay and / or Power Switch check procedures if power is not available at the Power Relay.
8. If no low voltage loads operate verify the low voltage, 24VDC, is present at J35.
9. If a single load does not operate, low voltage or line voltage, it is possible the load is defective. Refer to the check procedures for the particular load.
10. Refer to the wiring diagram for the SRB input and output connections.

Terminals:

ACROSS THE TOP EDGE

- J15 (N) / J16 (L1) - Right Blender Control 230VAC
- J11 (N) / J12 (L1) - Left Blender Control 230VAC
- J27 (N) / J28 (L1) - CIP Enable 230VAC
- J24 (N) / J23 (L1) - Bin Level Relay 230VAC
- J21 / J22 - Future Use
- J17 / J18 - Future Use
- J25 (N) / J26 (L1) - Ice Carousel 230VAC
- J13 (N) / J14 (L1) - Cabinet Refrigeration 230VAC
- J19 (N) / J20 (L1) - Ice Compressor 230VAC
- J9 (N) / J10 (L1) - 230VAV Switched Input Voltage

LEFT SIDE

- J1 - Pins 1-9 Switched -24VDC Product solenoids / Pin 10 dispense water valve / Pin 11 +24VDC to product solenoids.
- J2 - Signal Inputs - Bin Level Sensor / Ice Wheel Reed Switch

RIGHT SIDE TOP TO BOTTOM

- J34 - Defrost Thermistor Probe
- J33 - Nozzle Thermistor Probe
- J32 - Cabinet Probe
- J31 - Ice Condenser Probe
- J30 - Cabinet Condenser Probe
- J29 - Future use

BOTTOM

- J4 - No connector (not used)
- J6 - Modbus / UI Communication
- J5 - Future Use
- J7 - Modbus / Right Blender Communication
- J8 - Modbus / Left Blender Communication
- J35 - 24VDC Input
- J36 - Duct Fan / 24VDC

NOTE: See “SRB Board” on page 278.

SRB BOARD

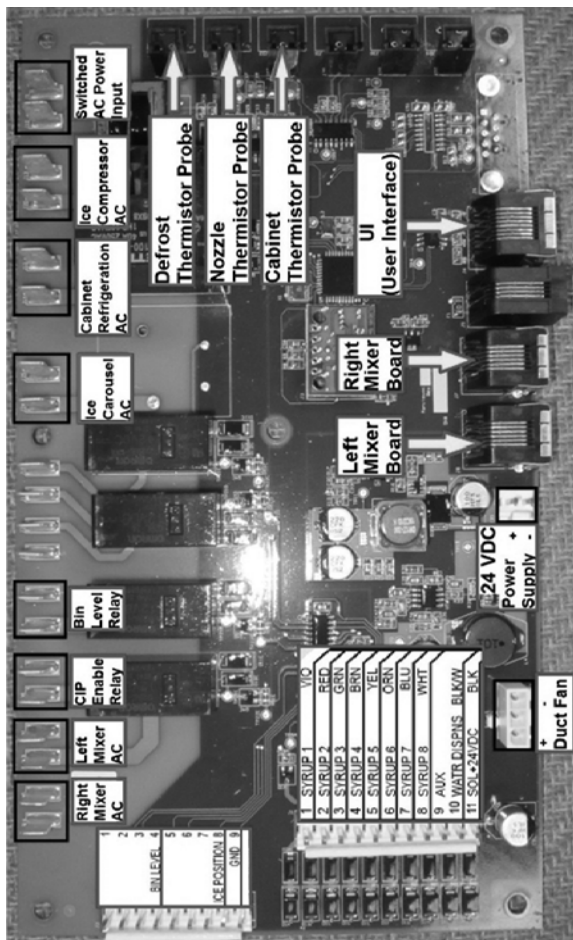

BLENDER CONTROL BOARD

Location

Each blend chamber has a dedicated Blender Control Board. The unit side panel will need to be removed for access to the board. The right side panel would be removed to access the right side Blender Control Board - the left side panel would be removed to access the left side panel.

Function

The Blender Control Board provides control of the blender position, up/down movement of the linear slide, and on/off motor operation. The Blender Control Board is software driven and retains firmware which can be updated via the USB port, near the power switch on the left side of the unit.

Specifications

The Blender Control Board receives 230VAC line voltage and 24VDC low voltage. The blender board executes the blend profile of the customer's recipe when a drink is selected. The board will distribute voltage to the blender motor, linear slide, or the rinse water solenoid as instructed according to the current firmware and instruction from the UI. Instruction from the UI is transmitted via Modbus communication cable connected at J4. The blender also receives input from the blender door reed switch and the blender home position switch.

Check Procedure

The Blender Control Board function can be tested via the "Outputs" in the UI service screen. (Managers Menu> Service> Options) Operate the blender blade to verify blade operation and/or the blender slide to verify linear slide operation.

The blender door must be fully closed to allow blender operation. The door position can be confirmed using the "Inputs" screen - Managers Menu> Service> Inputs. This will verify the software is correctly reading the door position. Open the perspective door (left / right) and the Output should report the current condition, "open" or "closed"

Blender Board connections:

- J5 (N) / J6 (L1) - 230VAC
- J2 (N) / J7 (L1) - 230VAC
- J12 - Rinse Water Solenoid Valve, 24VDC
- J4 - Modbus communication
- J9 - Reed Switch / 3 wire
 - Brown to White - NC
 - Green to White - NO
- J13 - Home position switch - NO
- J10 - Linear Slide Stepper Motor
- J1 - 24VDC input (T1 +24VDC / T2 -24VDC)
- Onboard fuse - protects blender motor output circuit, 2.5 amp.
- DIP switch settings - All in the "OFF" position identifies the left side board, #1 switch in the "ON" position and #2, 3 & 4 in the "OFF" position identifies the right side board.
- Has one LED:
 - Constant when first powered on.
 - Blinks when linear slide reaches home.
 - Heartbeat after homing is accomplished.

NOTE: See "Blender Control Board" on page 281.

BLENDER CONTROL BOARD

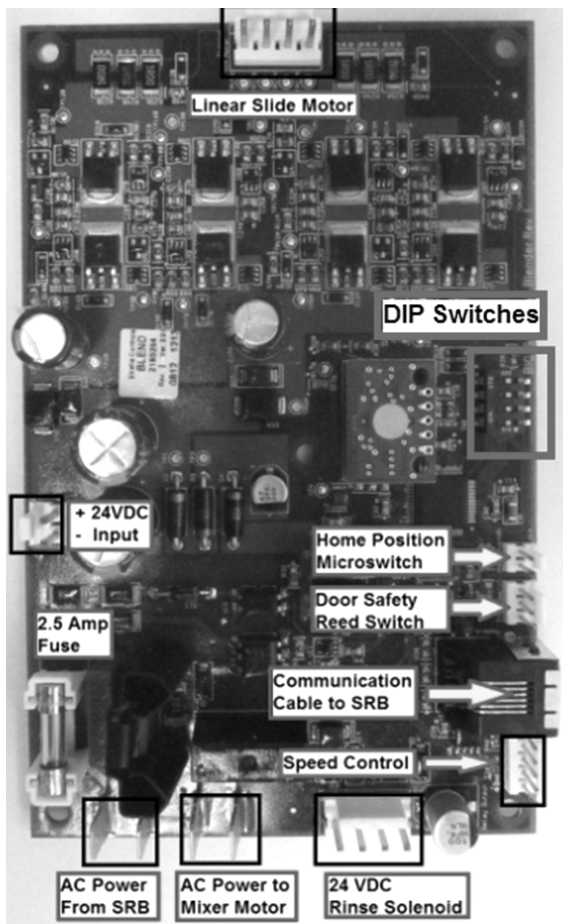

CIP (CLEAN IN PLACE) RELAY BOARD

Location

The CIP Board is located behind the left hand side panel, near the back of the unit.

Function

The CIP board controls component operations during Zone 3, monthly cleaning. This consists of the automated ice maker evaporator and ice bin sanitizing / descaling.

Specifications

Contains 8 (eight) 24VDC relays used to control various relays and solenoids during the automated ice system cleaning / descaling process. Each relay has an independent LED to indicate when the relay is energized.

Check Procedure

Operation of each relay can be verified by going to the "Cleaning Outputs" screen located in the "Service" section of the software. From the home screen of the UI, select "Manager> Service> Cleaning Outputs". Each of the 8 functions controlled can be independently energized for testing purposes. The corresponding relay should energize (LED illuminate) and activate the solenoid or relay associated to the function. All input and output from the CIP Relay Board is 24VDC.

NOTE: See "Blender Control Board" on page 281.

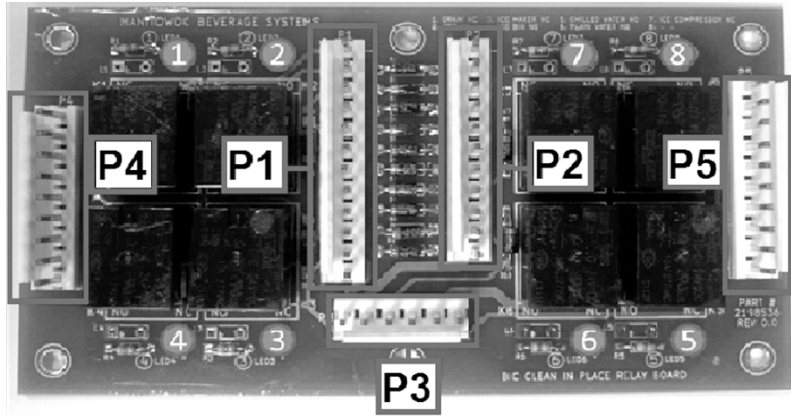
CIP (CLEAN IN PLACE) RELAY BOARD

- P1** - SRB / J1 (12 pin connector)
- P2** - Syrup and water Solenoids - Multi color wire 11 pin connector.
- P3** - CIP Enable Relay
- P4** - CIP Solenoids number 1 thru 4.
 - #1 - Ice Maker water drain solenoid.
 - #2 - Air/CO2 CIP pump supply solenoid.
 - #3 - Ice maker water reservoir solenoid.
 - #4 - Ice bin nozzle solenoid.
- P5** - CIP Solenoids number 5 thru 8.
 - #5 - Chilled water solenoid.
 - #6 - Water inlet solenoid(s).
 - #7 - Ice Compressor on/off relay.
 - #8 - Ice system power relay.

Beverage Components

PRESSURE REGULATOR - WATER OR CO₂

Function

Adjusts and maintains pressure.

Specification

WATER

Pressure Setting 35 psig (207 kPa)

CO₂

Pressure Setting 35 psig (241 kPa)

CHECK PROCEDURE

1. Verify incoming supply pressure is within the minimum and maximum specifications, the regulator is at setpoint and the supply line is sized correctly to supply sufficient flow.
2. Energize a valve that uses water or CO₂ and adjust the regulator to setpoint.
3. Test cycle the valve while observing the pressure gauge - If regulating valve will not maintain correct pressure, replace regulator.

NOTE: See "How to Adjust Air/CO₂ Pressure" on page 259.

WATER DISPENSE SOLENOID VALVE

Function

Opens and closes to control water flow.

Specifications

24 VDC

Check Procedure

CONTINUAL WATER FLOW

1. Place power switch in off position
- Flow continues - Replace valve
 - Flow stops - Replace relay board

NO WATER FLOW

1. Verify water is supplied.
 2. Energize the water valve.
 3. Check for line voltage at valve coil:
- Line voltage present - Replace water valve
 - Line voltage not present - Replace relay board.

SYRUP SOLENOID VALVE

Location

- In the base unit behind the product trays and the steel dividers. See “Bottom Cabinet” on page 45.
- Syrup Solenoid harness - LHS Rear of the unit on the CIP board position P2.
- Color coded 11pin connector block.

Function

Controls supply of CO₂ to product pump when required once the product has been selected by the recipe.

Specifications

- 24 VDC
- Single black wire is continues +24vIts supply, color wiring are neutral and represent each solenoid coil 1-8.
- 8x solenoid coils are N/C

Check Procedure

1. Verify pressure regulator setting is correct. 35 Psi dynamic.
2. Verify pressure is present at valve inlet.
 - Check by activating another valve on the same block. ie 1256-3478
3. Check for 24 VDC at the black terminal and at the selected color on the 11 pin connector. Position 2 on the CIP board.
 - 24 volts is not present - Refer to “Home Position Switch” on page 291.
 - 24 volts present - Continue
4. Relieve Air/CO₂ pressure, at the Tee and then disconnect outlet line.
5. Restore Air/CO₂ and test cycle valve:
 - Valve opens - Check for pinched lines and obstructions on the Air/CO₂/pipe work to the product pump. If there is no obstruction then replace the product pump.
 - Valve does not open - Replace solenoid valve assembly.

NON DRIP VALVE

Location

- In the base unit behind the product trays on the top rail. See “Bottom Cabinet” on page 45.

Function

As the Air/CO₂ is applied the diaphragm will flex to decrease the product volume inside the valve, when the air is released the diaphragm returns to its position increasing the volume and this causes a back feed from the LMS valve. Preventing excess product from dripping from the LMS valve

See “Dispense System Diagram” on page 317.

Specifications

- Requires Air/CO₂ pressure to operate.

Check Procedure

1. Product constantly dripping from a single valve.
2. Verify pressure regulator setting is correct +35 psi (241 kPa, 2.41 bar).
3. Verify pressure is present at valve inlet.
4. Verify cabinet temperature is not below freezing. A frozen valve can be thawed and made operational.
5. Clear blocked line; See “Procedure to Clear Blocked Line” on page 222.
6. Disconnect the air line from the Valve and press the NRV on the supply line to verify pressure is present.

NOTE: Air/CO₂ has high back pressure, please wear PPE)

7. If pressure is present then a new none drip valve will be required.

PRODUCT PUMP

Location

- In the base unit behind the product trays and steel dividers. See “Bottom Cabinet” on page 45.

Function

Transfers product from bag to cup.

Specifications

Pressure operated, requires 35 psi (241 kPa) Air/CO₂ pressure Dynamic.

Check Procedure

1. Verify cabinet temperature is not below freezing. A frozen pump can be thawed and made operational.
2. Clear blocked line; See “Procedure to Clear Blocked Line” on page 222.
3. Verify pressure regulator setting is correct.
4. Verify pressure is present at product pump inlet.
5. Disconnect the air line from the Valve and press the NRV on the supply line to verify pressure is present.

NOTE: Air/CO₂ has high back pressure, please wear PPE)

6. Disconnect pressure inlet line and product inlet and outlet lines from product pump.
7. Point pump inlet/outlet away from face and reconnect inlet pressure line:
 - Pump cycles - Check for pinched lines and obstructions.
 - Pump does not cycle - Replace pump.

STEP MOTOR

Function

Raises and lowers the blender blade to provide consistent mixing of ingredients.

Specification

5 VDC from Blender Board

Check Procedure

1. Disconnect the connector (MTA4), terminals TP12B, TP13B, TP14A and TP13A on the top of Blender Board. The Blender Board is located on the back of the Blender Assembly. See "Top Right" on page 44.
2. Check for 5 VDC across XXX.
 - Open (OL) = Replace motor
 - Resistance = Motor windings are good
3. Check rotor for excessive play or binding
4. Test home position switch
5. Test door switch(es)
6. Replace Blender Board.

BLENDER MOTOR

Function

Mixes ingredients to maintain a consistent product.

Specification

220 V 50hz

Check Procedure

Use a voltmeter/ohm meter to check motor operation.

1. Disconnect the Blue and White wires from the Blender motors. Blender Board is located on the back of the Blender Assembly.
 - Check resistance across the blender motor leads.



- Open (OL) = Replace motor
 - Resistance = 95 ohms motor is good
2. Check rotor for excessive play or binding
 3. Test capacitor
 4. Test home position switch
 5. Verify relay is closed/powered - if not test door switches
 6. Replace Blender Board

HOME POSITION SWITCH

Function

Prevents blender motor operation if the step motor does not return to the home (up) position.

Specification

SPST Normally Open Switch

Location

On Blender Assembly / Linear Slide bracket. One switch on left side bracket and one switch on the right side bracket.

Check Procedure

Use a voltmeter/ohm meter to check switch operation.

1. Inspect the switch for correct wiring. On Blender Board at J13 Terminal, 1 = Blue Terminal 2 = Brown.
2. Isolate the switch by disconnecting the wiring connectors. On Blender Board at J13 Terminal, 1 = Blue Terminal 2 = Brown.
3. Check continuity across the switch terminals in the open and closed position. Replace the switch if continuity readings do not match both switch settings. On Blender Board at J13 Terminal, 1 = Blue Terminal 2 = Brown.
 - Open (OL) = Replace motor
 - Resistance (0) = motor is good

DOOR SWITCHES

Function

Prevents blender motor operation if the door/switch is not closed.

Location

Magnetic switch is located on top of the Blend Chamber / Linear Slide Bracket access from the back side. The relay switch is located on each Blender Assembly bracket.

Specification

One (1) Magnetically operated SPST normally open switch per Blender per side. One (1) Relay switch per blender per side.

Check Procedure

Use a voltmeter/ohm meter to check switch operation.

1. Inspect the switch for correct wiring.
2. Isolate the switch by disconnecting the wiring connectors.
3. Check continuity across the switch terminals in the open and closed position.

Remove = (Replace the switch if continuity readings do not match both switch settings.)

- Open (OL) = Replace motor
- Resistance (0) = Switch is good

WATER RINSE SOLENOID VALVE

Function

Opens and closes to control water flow.

Location

The Water Rinse Solenoid Valve is located on each Blender Assembly/Linear Slide bracket.

Specifications

24 VDC

Check Procedure

CONTINUAL WATER FLOW

1. Place power switch in off position
 - Flow continues - Replace valve
 - Flow stops - Replace relay board
2. Turn power switch to the on position.
 - Open blender door.
 - If flow stops relay is good.
 - If flow continues check power to Solenoid coil if 24v is present replace Blender Board.

NO WATER FLOW

1. Verify water is supplied.
2. Energize the water valve.
3. Check for line voltage at valve coil:
 - Line voltage present - Replace water valve
 - Line voltage not present - Replace relay board.

Ice Machine Components

HIGH PRESSURE CUTOUT (HPCO) CONTROL

Function

Protects the compressor by interrupting the control signal to the control board. Excessive high side pressure operates the HPCO. The HPCO control is normally closed, and opens on a rise in discharge pressure.

Location

Above the ice compressor.

Specification

Cut-Out	Cut-In
29.30 bar \pm .69 425 psig \pm 10	Automatic Reset
Must be below 19.78 bar (287 psig) to reset.	

Check Procedure

1. With power off, isolate by disconnecting the wiring connectors.
2. Check continuity across the terminals with an ohm meter.
 - Low resistance = Continuity is good
 - Open (OL) = Replace HPCO

ICE MAKER BIN LEVEL RELAY

Function

Control signal from SRB to ice maker PCB.

Location

Right Hand Side, above the ice compressor.

Specification

Input 230vAC, terminals T0 and T1. Output 19vAC terminals T2 and T4.

Check Procedure

1. There is a test button on the side that when pushed will close the contacts.

ICE CONDENSER COIL FAN

Function

Pull air through the condenser coil to remove heat from the refrigerant.

Location

Behind condenser coil, access from Right Hand Side or back.

Specification

Input 230vAC, switched on when the compressor is switched ON.

Check Procedure

1. Isolate by disconnecting the wiring connectors.
2. Check continuity across the terminals with an ohm meter.
 - Resistance = Motor windings are good
 - Open (OL) = Replace motor
3. Check rotor for excessive play or binding.

INFRARED ICE BIN CONTROL

Function

Infrared ice bin control senses ice level and starts/stops ice production. It must sense for 10 seconds before switching off ice maker.

Location

Through the lid of the ice bin.

Specification

20-250 VAC 50/60hz, SPST, Dark Operated, 4 inch Sensing Range, Infrared LED, Solid State Switch.

Check Procedure

Ensure protective tube is fitted over lens to prevent splashes from rinse nozzle. If there are splashes / droplets on the lens, ice maker will not switch on until these have evaporated.

NOTE: Sensor is reverse acting - The sensor sends a power signal on the black wire until ice is sensed. When ice is sensed power is removed from the black wire.

1. No red LED indicates the sensor is not detecting anything close.
2. Red LED indicates sensor is detecting close to lens, (ice bin full).

Optic Sensor

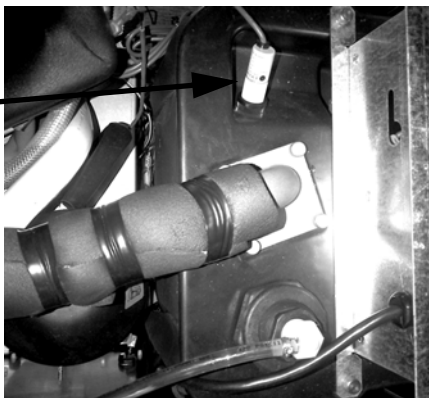

Refrigerated Cabinet

TEMPERATURE THERMISTOR - NOZZLE, CABINET OR DEFROST

Location

- Nozzle Thermistor - Behind the front fascia inside the duct area connected to the product line.
- Cabinet Thermistor - Attached to the evaporator plate in the base unit.
- Defrost Thermistor - Inserted into the evaporator coil.

Function

Supplies input to the SRB board to indicate nozzle, cabinet or defrost temperature. The SRB board energizes and de-energizes the compressor based on input from the thermistors.

Specifications

5,000 Ohms \pm 2% at 25°C (77°F)

16,330 Ohms \pm 2% at 0°C (32°F)

Check Procedure

NOTE: Use a multimeter to check operation.

1. Reboot machine by moving toggle switch off/on.
2. Inspect for correct wiring on the SRB Board.
 - Nozzle connection terminal J33
 - Cabinet connection terminal J32
 - Defrost connection terminal J34
3. Isolate by disconnecting the wiring connectors.
4. Check continuity across the terminals with an ohm meter.
 - Resistance = Thermistor is good
 - Open (OL) = Replace thermistor

NOTE: These thermistors are identical. Swapping the thermistor connections at the SRB board can be used for diagnostics.

Temperature/Resistance Chart

This chart is used for the temperature control thermistors. As the temperature rises at the thermistor block, the resistance drops.

If the ohmmeter reads "OL," check the scale setting on the meter before assuming the thermistor is bad.

°C	°F	OHM
-17.8	0	43,297
-15.0	5	36,503
-12.2	10	30,884
-9.4	15	26,948
-6.7	20	22,928
-3.9	25	20,082
-1.1	30	17,188
1.7	35	14,751
4.4	40	13,019
7.2	45	11,506
10.0	50	9,951

EVAPORATOR FAN MOTOR

Location

On the top of the evaporator.

Function

Moves cabinet air through the evaporator to maintain cabinet temperature at set point.

Specification

2x evaporator 220V, 50hz fan motors.

Check Procedure

1. Check the wiring on the power supply terminal CN2 pins 2&5.
2. Check 230 VAC present at terminal CN2 pins 2&5.
3. If voltage is present follow the below procedures.
4. Isolate by disconnecting the wiring connectors.
5. Check continuity across the terminals with an ohm meter.
 - Resistance = Motor windings are good
 - Open (OL) = Replace motor
6. Check rotor for excessive play or binding

DUCT FAN MOTOR

Location

Top of the base cabinet below the duct opening.

Function

Moves cool air from the cabinet through the tubing chase to maintain cabinet temperature in the beverage lines.

Specifications

24 VDC 2.4 watt

Check Procedure

1. Check wiring connections on SRB terminal J36
2. Isolate by disconnecting the wiring connectors.
3. Check continuity across the terminals with an ohm meter.
 - Resistance of $17M\Omega \pm 10\%$ = Motor is good
 - Open (OL) = Replace motor
4. Check rotor for excessive play or binding

CONDENSER FAN MOTOR

Location

At the rear of the base unit, behind the panels on the condensing unit.

Function

Moves air through the condenser to condense refrigerant from vapor to liquid state.

Specification

230VAC 9 watts.

Check Procedure

1. Isolate by disconnecting the main power supply.
2. Check that the fan blade is secured to the motor.
3. Check the blade spins freely.
4. Check rotor for excessive play or binding
5. Remove the wiring from the terminal connectors and check continuity across the terminals with an ohm meter.
 - Resistance = Motor windings are good
 - Open (OL) = Replace motor

COMPRESSOR ELECTRICAL DIAGNOSTICS

Location

On the base unit behind the rear panels.

Specification

R-290 220-240/50 - 1/5HP, TL4CN

Check Procedure - The compressor does not start or will trip repeatedly on overload

CHECK RESISTANCE (OHM) VALUES

Compressor windings can have very low ohm values. Use a properly calibrated meter.

Perform the resistance test after the compressor cools. The compressor dome should be cool enough to touch (below 120°F/49°C) to assure that the overload is closed and the resistance readings will be accurate.

SINGLE PHASE COMPRESSORS

Disconnect power, then remove the wires from the compressor terminals.

The resistance values between C and S and between C and R, when added together, should equal the resistance value between S and R.

If the overload is open, there will be a resistance reading between S and R, and open readings between C and S and between C and R. Allow the compressor to cool, then check the readings again.

CHECK MOTOR WINDINGS TO GROUND

Check continuity between all three terminals and the compressor shell or copper refrigeration line. Scrape metal surface to get good contact. If continuity is present, the compressor windings are grounded and the compressor should be replaced.

COMPRESSOR DRAWING LOCKED ROTOR

To determine if the compressor is seized, check the amp draw while the compressor is trying to start.

The two likely causes of this are a defective starting component and a mechanically seized compressor.

To determine which you have:

Install high and low side gauges.

Try to start the compressor.

Watch the pressures closely.

If the pressures do not move, the compressor is seized. Replace the compressor.

If the pressures move, the compressor is turning slowly and is not seized. Check the capacitors and relay.

COMPRESSOR DRAWING HIGH AMPS

The continuous amperage draw on start-up should not be near the maximum fuse size indicated on the serial tag.

DIAGNOSING CAPACITORS

If the compressor attempts to start, or hums and trips the overload protector, check the starting components before replacing the compressor.

Visual evidence of capacitor failure can include a bulged terminal end or a ruptured membrane. Do not assume a capacitor is good if no visual evidence is present.

Use a capacitor tester when checking a suspect capacitor. Clip the bleed resistor off the capacitor terminals before testing.

If the compressor hums and will not start but the windings are ok. Replace the start capacitor.

A good test is to install a known good substitute capacitor.

Filter-Driers

Location

Ice maker: Behind the compressor & cabinet: between compressor and condenser coil.

Function

To remove moisture and particulates from the refrigerant. This will prevent premature failure of the compressor and blocking of restrictor devices.

Specification

The size of the filter-drier is important due to a critical refrigerant charge. Using an improperly sized filter-drier will cause the refrigeration system to be improperly charged with refrigerant.

Driers are covered as a warranty part. The drier must be replaced any time the system is opened for repairs. Refer to the parts manual for the recommended OEM field replacement drier.

Check Procedure

The drier should not alter the temperature of the refrigerant. Compare the temperature of the copper pipe either side of the filter/drier, they should be the same.

If there is a temperature drop that indicates a partial blockage of the filter/drier and it should be replaced.

This Page Intentionally Left Blank

Charts

Total System Refrigerant Charge

This information is for reference only. Refer to the Blend-In-Cup Beverage System model/serial number tag to verify the system charge. Serial plate information overrides information listed on these pages.



Warning

Refrigerant type and amount varies by model. Machines may use R404A or R290 refrigerant. Always refer to model/serial plate to identify refrigerant type and amount.



Warning

Some 50 hz models may contain up to 150 grams of R290 (propane) refrigerant. R290 (propane) is flammable in concentrations of air between approximately 2.1% and 9.5% by volume (LEL lower explosion limit and UEL upper explosion limit). An ignition source at a temperature higher than 470°C is needed for a combustion to occur. Refer to nameplate to identify the type of refrigerant in your equipment.

Model	Refrigerant Charge
All R290 Cabinets	4.75 Ounces (134.70 Grams) R290
R290 Ice Machine MB-8-1PP	3.17 Ounces (90 Grams) R290

Operational Charts

Characteristics will vary depending on operating conditions.

R290 REFRIGERANT - ICE MACHINE

Models: MB-8-1PP

Air Temperature/ Water Temperature °C	24 Hour Ice Production	kWH/45 kg
21°C/10°C	186 kg	4.21
32°C/10°C	156 kg	5.24
43°C/38°C	122 kg	6.93

Air Temperature Entering Condenser °C	Discharge Temperature	Suction Temperature
21°C	31-38	-24 to -17
32°C	38-46	-23 to -17
43°C	48-54	-20 to -15

Diagrams

Wiring Diagrams

The following pages contain electrical wiring diagrams. Be sure you are referring to the correct diagram for the Blend-In-Cup Beverage System you are servicing.



Warning

Always disconnect power before working on electrical circuitry.

R290 ICE MACHINE REFRIGERANT - ICE MAKER WIRING DIAGRAM

Models: MB-8-1PP

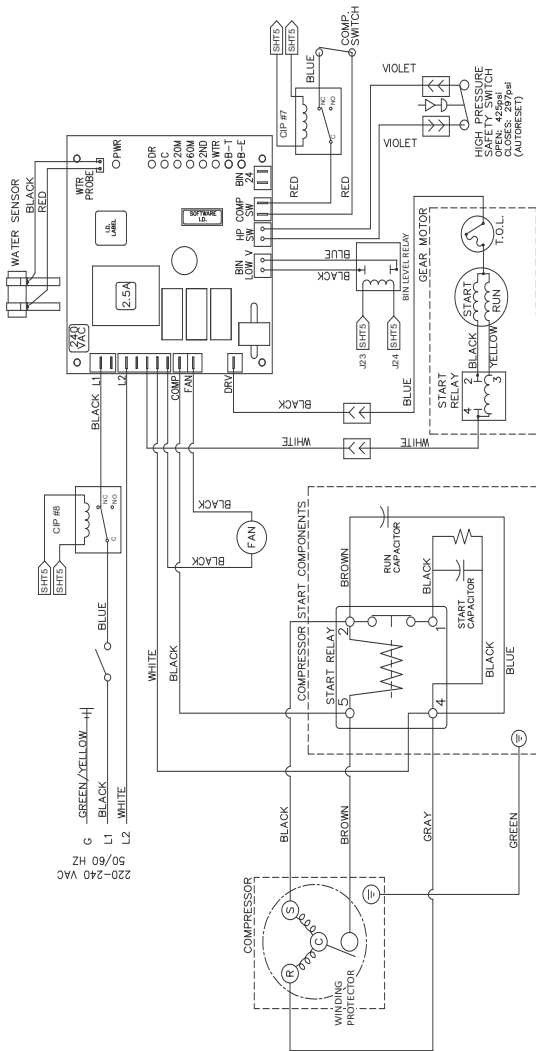

R290 ICE MACHINE REFRIGERANT - CIP BOARD WIRING DIAGRAM

Models: MB-8-1PP

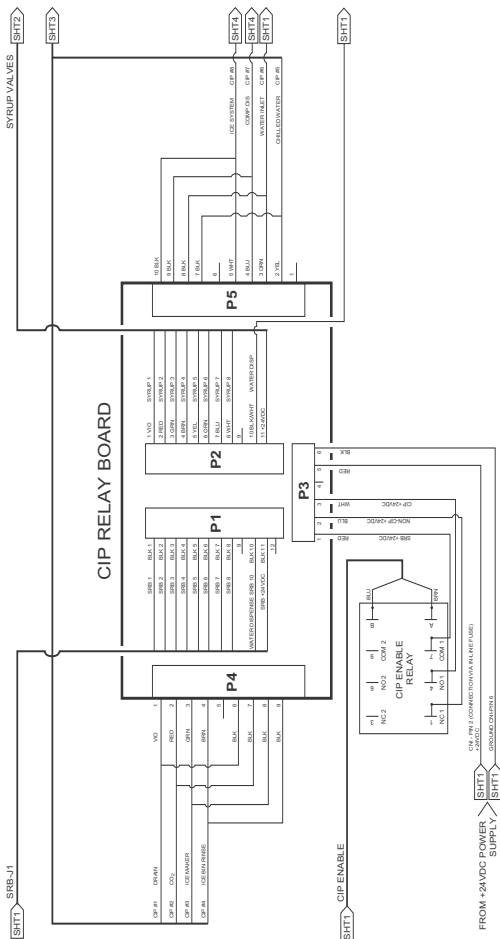

Nominal Operating Voltage for Loaded Electrical Components					
Component	High Voltage AC	24v DC Voltage	Low Voltage AC	Modbus	Other
Gear Motor, Ice Maker	X				
Compressor, Ice Maker	X				
Condenser Fan, Ice Maker	X				
Evaporator Fan, Refrigerator Base	X				
Evaporator Fan, Duct		X			
Condenser Fan, Refrigerator Base	X				
Compressor, Refrigerator Base	X				
Mixer / Blender, Linear Motor, Rotation Motor	X	X	X		
Product Solenoid Valve, Refrigerator Base		X			
CO2 / Air Solenoid Valve		X			
Water Solenoid Valve, Plain, Chilled		X			
Relay	X	X			
Power Supply - High Voltage to 24v DC Transformer	X	X (OUT)			
UI Assembly (Board, Touchpad)		X			X
Mixer / Blender Board Assembly	X	X			X
SRB Assembly, Control Board to All Components	X	X	X		X

Notes:

Voltage into Load Component except as noted

High Voltage AC - Refer to Nameplate Rating

Low Voltage AC - Less than 10v AC

Other - Refer to Tech Manual for details

Nominal Operating Voltage for Sensors						
Sensors	High Voltage AC	24v DC Voltage	Low Voltage AC	Modbus	Other	
Temperature - Drive, Defrost, Nozzle, Cabinet			X		X	
Ice Bin Level		X				
Ice Position Dispense Wheel		X				
Mixer / Blender, Limit Switches		X	X			
High Pressure Switch - Refrigeration		X				
Water Sensor Reservoir ice Maker			X			
Mixer / Blender Door Switches		X				
Notes:						
Voltage Into Load Component except as noted						
High Voltage AC - Refer to Nameplate Rating						
Low Voltage AC - Less than 10v AC						
Other - Refer to Tech Manual for details						

ICE MACHINE CLEANING & SANITIZING DIAGRAM

Models: MB-8-1PP

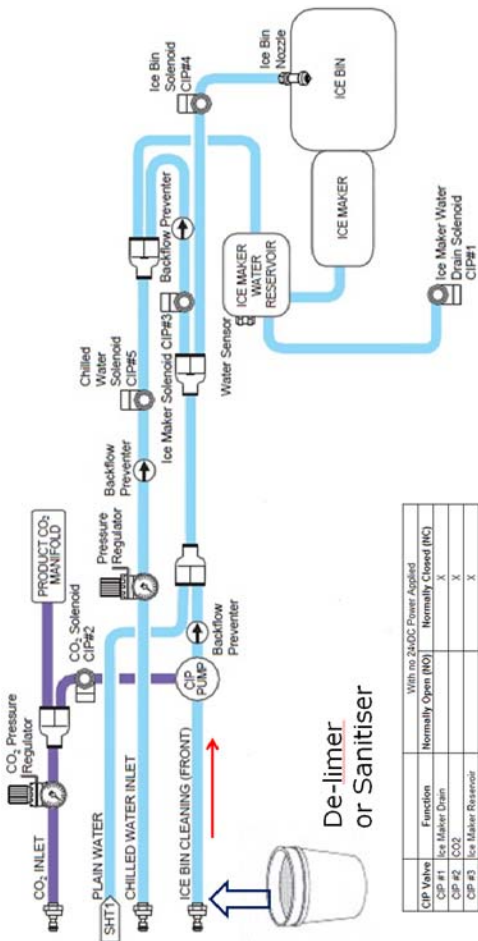

CIP Valve	Function	With no 24-DC Power Applied	
		Normally Open (NO)	Normally Closed (NC)
CP #1	Ice Maker Drain	X	
CP #2	CO2		X
CP #3	Ice Maker Reservoir	X	X
CP #4	Ice Bin Nozzle		X
CP #5	Chilled Water	X	
CP #6	Water Inlet	X	
CP #7	Ice Maker Compressor		Connected to Relay - Ice Maker
CP #8	Ice Maker Power		Connected to Relay - Ice Maker

ICE MACHINE CLEANING & SANITIZING DIAGRAM

Models: MB-8-1PP

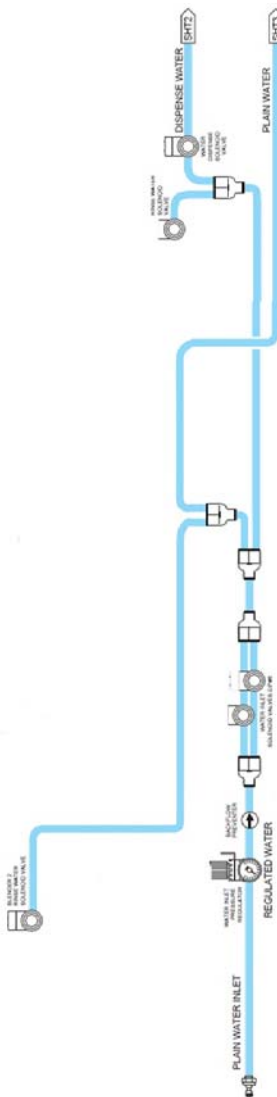

CIP Valve	Function	With no 24VDC Power Applied	
		Normally Open (NO)	Normally Closed (NC)
CIP #1	Ice Maker Drain		X
CIP #2	CO2		X
CIP #3	Ice Maker Reservoir		X
CIP #4	Ice Bin Nozzle		X
CIP #5	Chilled Water	X	
CIP #6	Water Inlet	X	
CIP #7	Ice Maker Compressor		Connected to Relay - Ice Maker
CIP #8	Ice Maker Power		Connected to Relay - Ice Maker

DISPENSE SYSTEM DIAGRAM

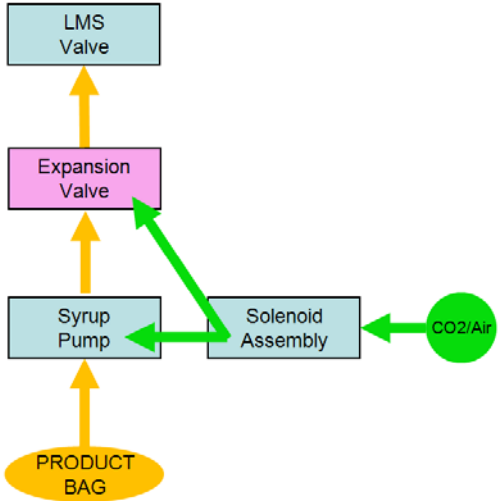

Expansion Valve

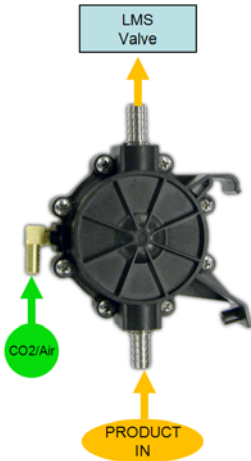

This Page Intentionally Left Blank



Maniowoc Foodservice
2100 Future Drive
Sellersburg, IN 47172, USA
Ph: 001-812-246-7000 Fax: 001-812-246-7026
Visit us online at: www.maniowocbeverage.com