

# Blend-In-Cup (BIC) Beverage System

## Installation, Operation and Maintenance Manual

Original Instructions — This manual is updated as new information and models are released. Visit our website for the latest manual. [www.manitowocbeverage.com/us](http://www.manitowocbeverage.com/us)



## Safety Notices

As you work on Multiplex equipment, be sure to pay close attention to the safety notices in this manual. Disregarding the notices may lead to serious injury and/or damage to the equipment.

Throughout this manual, you will see the following types of safety notices:

### **Warning**

Text in a Warning box alerts you to a potential personal injury situation. Be sure to read the Warning statement before proceeding, and work carefully.

### **Caution**

Text in a Caution box alerts you to a situation in which you could damage the equipment. Be sure to read the Caution statement before proceeding, and work carefully.

## Procedural Notices

As you work on Multiplex equipment, be sure to read the procedural notices in this manual. These notices supply helpful information which may assist you as you work.

Throughout this manual, you will see the following types of procedural notices:

### **Important**

Text in an Important box provides you with information that may help you perform a procedure more efficiently. Disregarding this information will not cause damage or injury, but it may slow you down as you work.

NOTE: Text set off as a Note provides you with simple, but useful, extra information about the procedure you are performing.

## Read These Before Proceeding:

### **Caution**

Proper installation, care and maintenance are essential for maximum performance and trouble-free operation of your Multiplex equipment. Read and understand this manual. It contains valuable care and maintenance information. If you encounter problems not covered by this manual, do not proceed, contact Manitowoc Foodservice. We will be happy to provide assistance.

### **Important**

Routine adjustments and maintenance procedures outlined in this manual are not covered by the warranty.

### **Warning**

#### **PERSONAL INJURY POTENTIAL**

Do not operate equipment that has been misused, abused, neglected, damaged, or altered/modified from that of original manufactured specifications.

NOTE: SAVE THESE INSTRUCTIONS.

We reserve the right to make product improvements at any time. Specifications and design are subject to change without notice.

# Table of Contents

---

## Section 1 General Information

<b>Read This Manual</b> .....	<b>5</b>
<b>About Blend-In-Cup</b> .....	<b>5</b>
<b>Unit Inspection</b> .....	<b>5</b>
<b>Model Numbers</b> .....	<b>5</b>
<b>Serial Number Location</b> .....	<b>5</b>
<b>Warranty Information</b> .....	<b>6</b>
<b>Specifications</b> .....	<b>7</b>
Dimensions.....	7
Capacity & Weight.....	7
Product Delivery Location.....	8
Refrigerant Charge.....	8
R-290 Ice Maker.....	8
R-404A Ice Maker.....	9
Electrical .....	10
Air / CO <sub>2</sub> , Plain & Chilled Water Inlets .....	11
System Pressures .....	11
Drain Connections .....	11

## Section 2 Installation

<b>Step-by-Step Installation</b> .....	<b>13</b>
Pre-installation Checklist.....	13
Connections .....	14
Installation Checklist.....	15
Start-Up & Cleaning.....	15
Demonstrate .....	16
Post Installation Checklist .....	16

## Section 3 Operation

<b>Component Identification</b> .....	<b>17</b>
<b>Sequence of Operation</b> .....	<b>17</b>
Normal Operation .....	17
Ice Making.....	18
<b>Touch Screens</b> .....	<b>19</b>
Drink Selection Screen .....	19
Flavor Selection Screen.....	20
Size Screen.....	21
Main Menu Screen .....	24
Manager's Menu Screen.....	25
Calibration Procedure.....	27
Product Inventory Screen.....	29
Cleaning Screen .....	31
<b>Other Operations</b> .....	<b>32</b>
Loading Recipes.....	32
Recommended Cups.....	32

**Section 4  
Maintenance**

**General Maintenance..... 33**  
 Door Gasket Maintenance ..... 33  
 Drain Maintenance - Inside Lower Cabinet..... 33  
 Refrigerators..... 34  
 Stainless Steel Care & Cleaning ..... 34  
 Doors/Hinges..... 34  
 Preventing Blower Coil Corrosion ..... 34  
**Daily Cleaning - Zone 1 ..... 35**  
 Gather the Following Supplies ..... 35  
 Blenders / Dispense Area Cleaning & Sanitizing ..... 36  
**Weekly Cleaning - Zone 2 ..... 40**  
 Gather the Following Supplies ..... 40  
 Product Line Cleaning & Sanitizing ..... 41  
 Sanitizing Ice Bin & Water Nozzles (Optional) ..... 43  
 Blenders / Dispense Area Cleaning & Sanitizing ..... 45  
 Drain Cleaning (Optional) ..... 49  
**Monthly Cleaning - Zone 3 ..... 51**  
 Gather the Following Supplies ..... 51  
 Ice Maker Cleaning & Sanitizing..... 52  
 Other Monthly Tasks..... 55  
**Biannual Descaling - Zone 3 ..... 56**  
 Turn ON Descaling ..... 56  
 Gather the Following Supplies ..... 57  
 Ice Maker / Bin Descaling, Cleaning & Sanitizing..... 58  
 Turn OFF Descaling..... 62  
**Ice Machine Cleaning ..... 63**  
 Tools Required..... 63  
 Unit Preparation..... 63  
 Ice Machine Descaling..... 63  
 Ice Machine Sanitizing..... 64  
 Bin / Dispenser Descale, Clean, & Sanitize..... 64  
 Descaling..... 64  
 Sanitizing..... 64  
 Full Disassembly Descale, Clean & Sanitize..... 65  
**Product Line Flush..... 66**  
 Gather the Following Supplies ..... 66  
**Annual Planned Maintenance ..... 71**

**Section 5  
Troubleshooting**

**Before Calling For Service Checklist ..... 73**  
**Procedure to Clear Blocked Line ..... 75**  
**How to Check Air/CO<sub>2</sub> Pressure ..... 76**  
**How to Check Plain Water Pressure ..... 77**

**Section 6  
Tools & Cleaning Supplies**

**Cleaning Kits..... 79**

# Section 1

## General Information

### Read This Manual

Manitowoc Beverage Systems developed this manual as a reference guide for the owner/operator and installer of this equipment. Please read this manual before installation or operation of the machine. A qualified service technician must perform installation and start-up of this equipment. Consult **Section 5** within this manual for service assistance.

If you cannot correct the service problem, call your Service Agent or Distributor. Always have your model and serial number available when you call.

Your Service Agent \_\_\_\_\_

Service Agent Telephone Number \_\_\_\_\_

Your Local Distributor \_\_\_\_\_

Distributor Telephone Number \_\_\_\_\_

Model Number \_\_\_\_\_

Serial Number \_\_\_\_\_

Installation Date \_\_\_\_\_

### About Blend-In-Cup

The Blend-In-Cup beverage system is a self-contained dispensing unit that allows the operator to make flavor combinations of blended and non-blended drinks. It holds product flavoring in a refrigerated reach-in base enclosure, has a refrigerated ice making machine and includes one or two mixing modules.

The operator controls and accesses the unit using a lighted touch screen. Icons on the drink selection screens represent the primary flavor combinations for the drinks. There are multiple drink size options. Menu changes and additions are uploaded using a USB mass storage device and the Menu Connect Software platform.

On-screen instructions also include operator procedures for cleaning/sanitizing, checking inventory, replacing product bags, selecting drink sizes and manually preparing drinks. Managers and technicians have access to menu/software updates, diagnostics and other service screens.

### Unit Inspection

Thoroughly inspect the unit upon delivery. Immediately report any damage that occurred during transportation to the delivery carrier. Request a written inspection report from a claims inspector to document any necessary claim. See "Pre-installation Checklist" on page 13.

#### ⚠ Warning

Do not damage the refrigeration circuit when installing, maintaining or servicing the unit.

#### ⚠ Warning

Do not operate equipment that has been misused, abused, neglected, damaged, or altered/modified from that of original manufactured specifications.

This appliance is not intended for use by persons (including children) with reduced physical, sensory or mental capabilities, or lack of experience and knowledge, unless they have been given supervision concerning use of the appliance by a person responsible for their safety.

### Model Numbers

This manual covers the following models:

#### Blend-In-Cup Beverage Systems

MB-8-1, MB-8-2, MB-8-1A, MB-8-2A, MB-8-1BF, MB-8-1D,  
MB-8-2D, MB-8-1E, MB-8-2E, MB-8-1P, MB-8-2P,  
MB-8-1PP, MB-8-1U, MB-8-2U

### Serial Number Location

The Blend-In-Cup beverage system serial number is listed on the serial number decal affixed to the middle of the lower back panel. Another serial number decal is located on the right side of the machine.

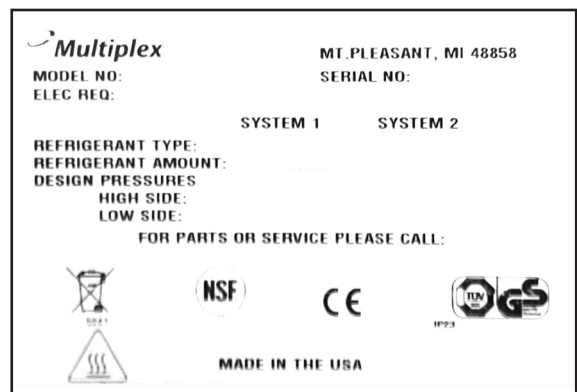

Sample Serial Tag

## Warranty Information

Consult your local Service Agent or Representative for terms and conditions of your warranty. Your warranty specifically excludes all general adjustments, cleaning, accessories and related servicing.

Your warranty card must be returned to activate the warranty on this equipment. If a warranty card is not returned, the warranty period can begin when the equipment leaves the Manitowoc Beverage Systems factory.

No equipment may be returned to Manitowoc Beverage Systems without a written Return Materials Authorization (RMA). Equipment returned without an RMA will be refused at Manitowoc Beverage System's dock and returned to the sender at the sender's expense.

Please contact your local distributor for return procedures. Full explanation of the Limited Warranty for Multiplex Blended Ice Machines can be found in the warranty statement at the back of this manual.

## Specifications

### DIMENSIONS

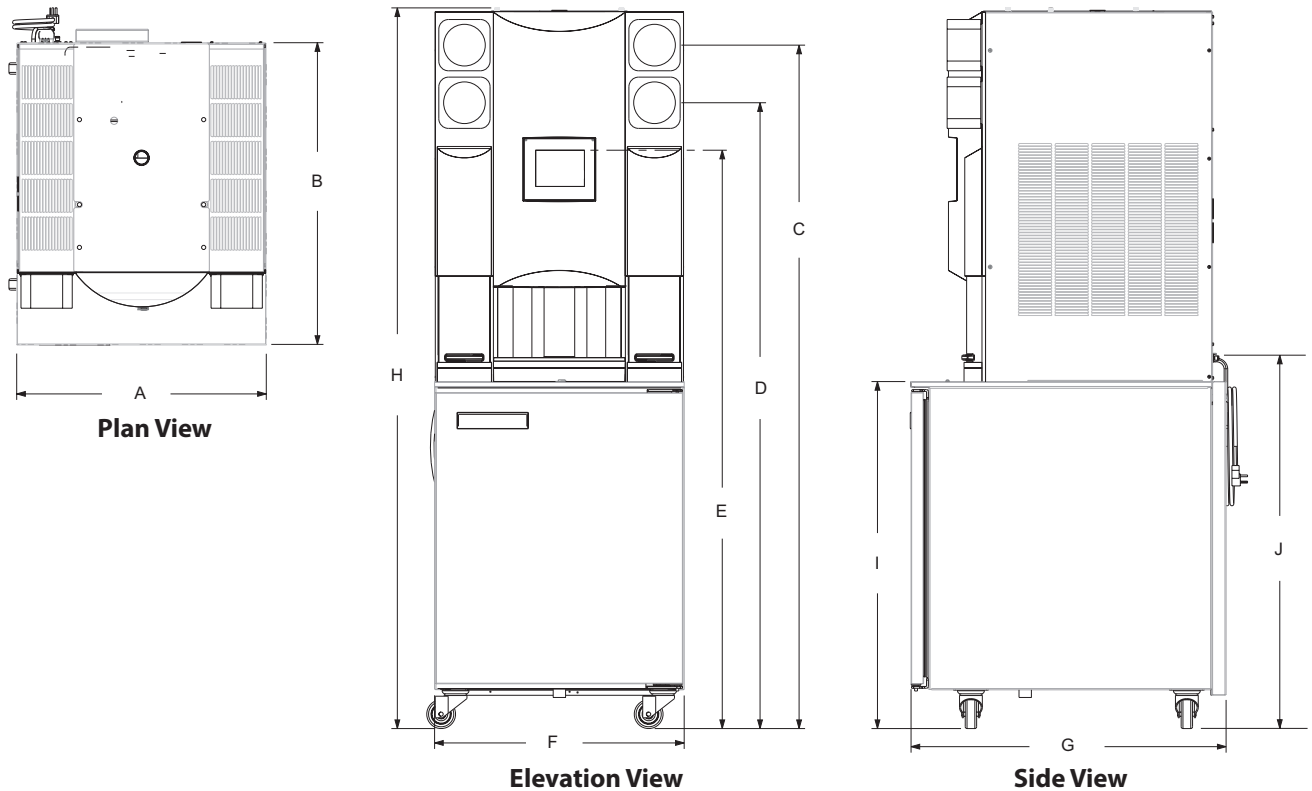

A	26.00" (66 cm)	C	71.19" (181 cm)	E	60.25" (153 cm)	G	32.82" (83 cm)	I	36.15" (92 cm)
B	32.82" (83 cm)	D	65.19" (166 cm)	F	26.00" (66 cm)	H	75.07" (191 cm)	J	39.09" (99 cm)

**⚠ Warning**

To avoid instability the installation area must be capable of supporting the weight of the equipment and a full bin of ice. Additionally the equipment must be level side to side and front to back.

### CAPACITY & WEIGHT

	Ice Capacity	HP	Max Product Bin Load	Shipping Weight	Empty Weight	Full Weight
Lower Cabinet	–	1/5	19.8 lbs (9 kg)	606 lbs (275 kg) Crated	492 lbs (223 kg) Unpacked No Ice/ Product	656 lbs (298 kg) With Ice/ Product
Ice Maker	310 lbs (141 kg)/24 hr. Bin Storage 30 lbs (14 kg)	1/2	–			

**PRODUCT DELIVERY LOCATION**

The location selected for the Blend-In-Cup Beverage System must meet the following criteria.

- The air temperature must be at least 40°F (4°C), but must not exceed 90°F (32°C), climate class 4.
- The location must not be near heat-generating equipment or in direct sunlight and must be protected from weather.
- Plain or Chilled Inlet Water Temperature: min/max = 40°F / 90°F (4°C / 32°C).
- Always use the water supply line supplied when installing this appliance. Never reuse an old supply line.
- Verify floor of install location is within 1/2" (1.3 cm) of level front to back, side to side.
- Keep equipment area clear of combustible material.

**⚠ Warning**

Carbon Dioxide (CO<sub>2</sub>) displaces oxygen. Exposure to a high concentration of CO<sub>2</sub> gas causes tremors, which are followed rapidly by loss of consciousness and suffocation. If a CO<sub>2</sub> gas leak is suspected, particularly in a small area, immediately ventilate the area before repairing the leak. CO<sub>2</sub> lines and pumps must not be installed in an enclosed space. An enclosed space can be a cooler or small room or closet. This may include convenience stores with glass door self serve coolers. If you suspect CO<sub>2</sub> may build up in an area, venting of the B-I-B pumps and / or CO<sub>2</sub> monitors must be utilized.

**Clearances**

Top	18" (46 cm)
Sides	6" (15 cm)
Back	6" (15 cm)
Front	30" (76 cm)

**⚠ Warning**

Do not obstruct machine vents or openings.

**Heat of Rejection**

Model	Heat of Rejection BTU/h
All Single & Dual Spindle Base (Cabinet 1)	2100
Ice Maker (Cabinet 2)	5150

**REFRIGERANT CHARGE**

**Important**

Due to continuous improvements, this information is for reference only. Please refer to the serial number tag to verify electrical data. Serial tag information overrides information listed on this page.

	R-290 Models	R-404A Models
Lower Cabinet (Cabinet 1)	4.75 oz. (134.7 g)	12 oz. (339 g)
Ice Maker (Cabinet 2)	3.17 oz. (90 g)	16 oz. (454 g)

**R-290 ICE MAKER**

Acceptable incoming water temperature range is 40°F (4°C) to 90°F (32°C). Optimum Range is 45°F (7°C) to 50°F (10°C) (Target 50°F [10°C], results based on ARI capacity testing @ 70°F [21°C] air temperature).

Ice Production		
Air Temperature/ Water Temperature	24 Hour Ice Production	kWh/100 lbs (45 kg)
70°/50°F (21°/10°C)	410 lbs (186 kg)	4.21
90°/70°F (32°/21°C)	343 lbs (156 kg)	5.24
110°/100°F (43°/38°C)	270 lbs (122 kg)	6.93

NOTE: If chilled water is being used, depending on the incoming Water Temp, the use of a chiller can drive an increase in ice capacity between 50 lbs (23 kg) and 125 lbs (57 kg) per day.

**R-404A ICE MAKER**

Acceptable incoming water temperature range is 40°F (4°C) to 90°F (32°C). Optimum Range is 45°F (7°C) to 50°F (10°C) (Target 50°F [10°C], results based on ARI capacity testing @ 70°F [21°C] air temperature).

<b>Ice Production</b>		
Air Temperature/ Water Temperature	24 Hour Ice Production	kWh/100 lbs (45 kg)
70°/50°F (21°/10°C)	430 lbs (195 kg)	4.927
90°/70°F (32°/21°C)	325 lbs (147 kg)	6.912
100°/90°F (38°/32°C)	270 lbs (122 kg)	8.568

NOTE: If chilled water is being used, depending on the incoming Water Temp, the use of a chiller can drive an increase in ice capacity between 50 lbs (23 kg) and 125 lbs (57 kg) per day.

**ELECTRICAL**

**⚠ Warning**  
 All wiring must conform to local, state and national codes.

**Minimum Circuit Ampacity**

The minimum circuit ampacity is used to help select the wire size of the electrical supply. (Minimum circuit ampacity is not the Blend-In-Cup Beverage System’s running amp load.) The wire size (or gauge) is also dependent upon location, materials used, length of run, etc., so it must be determined by a qualified electrician.

**Voltage**

A dedicated electrical circuit is required, a power cord is provided with all units. Some models are available in different voltages and may be equipped with a different plug. Refer to Blend-In-Cup Beverage System Model/Serial Plate for voltage/ampereage specifications.

**Minimum Circuit Amperage Chart**

**Important**

Due to continuous improvements, this information is for reference only. Please refer to the serial number tag to verify electrical data. Serial tag information overrides information listed on this page.

Model	Voltage/Cycle/Phase	Total Amps	Breaker Size (Max)
<b>MB-8-1</b>	120/60/1	16.0	20A
<b>MB-8-2</b>			
<b>MB-8-1A</b>	220/50/1	8.7	
<b>MB-8-2A</b>			
<b>MB-8-1D</b>			
<b>MB-8-2D</b>			
<b>MB-8-1E</b>			
<b>MB-8-2E</b>			
<b>MB-8-1P</b>			
<b>MB-8-2P</b>			
<b>MB-8-1U</b>			
<b>MB-8-2U</b>			
<b>MB-8-1BF</b>	230/60/1	6.4	
<b>MB-8-1PP</b>	230-240/50/1	6.4	

**Grounding Instructions**

**⚠ Warning**

The machine must be grounded in accordance with national and local electrical codes.

This appliance must be grounded. In the event of malfunction or breakdown, grounding provides a path of least resistance for electric current to reduce the risk of electric shock. This appliance is equipped with a cord having an equipment-grounding conductor and a grounding plug. The plug must be plugged into an appropriate outlet that is properly installed and grounded in accordance with all local codes and ordinances.

**⚠ Warning**

When using electric appliances, basic precautions must always be followed, including the following:

- A. Read all the instructions before using the appliance.
- B. To reduce the risk of injury, close supervision is necessary when an appliance is used near children.
- C. Do not contact moving parts.
- D. Only use attachments recommended or sold by the manufacturer.
- E. Do not use outdoors.
- F. For a cord-connected appliance, the following must be included:
  - Do not unplug by pulling on cord. To unplug, grasp the plug, not the cord.
  - Unplug from outlet when not in use and before servicing or cleaning.
  - Do not operate any appliance with a damaged cord or plug, or after the appliance malfunctions or is dropped or damaged in any manner. Contact the nearest authorized service facility for examination, repair, or electrical or mechanical adjustment.
- G. Follow applicable lock out tag out procedures before working on equipment.
- H. Connect to a properly grounded outlet only. See Grounding Instructions.

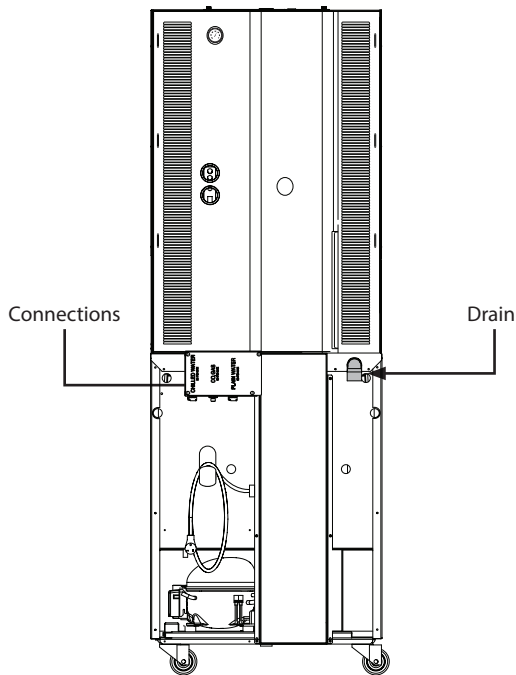
**AIR / CO<sub>2</sub>, PLAIN & CHILLED WATER INLETS****⚠ Warning**

Connect to a potable water supply only.

- Use supplied 3/8" (.95 cm) panel-mounted hose barb and 6' (1.8 m) of beverage tubing to connect labeled coupling body fitting(s) on back of unit for each supply connection.
- Do not connect either water connection to a hot water supply. Be sure all hot water restrictors installed for other equipment are working. (Check valves on sink faucets, dishwashers, etc.)
- Install a water shut-off valve in the water line at the rear of the machine.
- Insulate water inlet lines to prevent condensation.

**Hard Water**

In areas where the water is highly concentrated with minerals the water should be tested by a water treatment specialist, and the recommendations of the specialist regarding filtration and/or treatment should be followed.

**SYSTEM PRESSURES****Plain & Chilled Water****Important**

Requires the pressure measurement to be taken only when rinse water is spraying (flowing conditions) in a blender chamber.

- Plain Water Supply Pressure must be capable of continuously supplying a minimum of 35 psi (241 kPa, 2.41 bar) during flowing conditions.
- If a separate chilled water source is used, the chilled supply pressure needs to be a minimum of 35 psi (241 kPa, 2.41 bar) at no flow conditions.

**Important**

Water pressure affects the blender area cleaning, a water booster may be required if pressure is too low.

**Air / CO<sub>2</sub>****Important**

Requires the pressure measurement to be taken only when a product pump is being activated (product pump during flow conditions).

- Supply must be capable of 35 psi (241 kPa, 2.41 bar) minimum during flowing conditions, measured at the unit Air/CO<sub>2</sub> regulator. See "How to Check Air/CO<sub>2</sub> Pressure" on page 76.
- Supply to the unit not to exceed 50 / 80 psi (345 / 552 kPa, 3.45 / 5.52 bar) maximum during no flow conditions.

**DRAIN CONNECTIONS**

- Connect supplied 1" ID hose to hose-barb connection on machine.
- Drain lines must have a 1.5 inch drop per 5 feet of run (2.5 cm per meter), and must not create traps.
- The floor drain must be large enough to accommodate drainage from all drains.
- An air gap is included in the design of the machine for backflow prevention. Plumb to local code.

THIS PAGE INTENTIONALLY LEFT BLANK

## Section 2 Installation

### Step-by-Step Installation

These instructions are provided to assist the qualified installer. Contact your Manitowoc Foodservice Service Agent or call Manitowoc Foodservice for information regarding start-up services.

#### **Important**

Failure to follow these installation guidelines may affect warranty coverage.

### PRE-INSTALLATION CHECKLIST

- Keep product bags in a cooler at least 24 hours prior to installation.
- Any damage should be noted and reported to the delivering carrier immediately.
- Check the lower portion of the unit to be sure casters are not bent.
- Visually inspect the refrigeration package, compressor compartment housing. Be sure lines are secure and base is still intact.
- Inspect installation location behind the BIC for electrical outlet location, CO<sub>2</sub>, water hose fittings, and shutoff.
- Check voltage at outlet dedicated for BIC.
- Verify floor of install location is within 1/2" (1.3 cm) of level front to back, side to side and all casters are touching the floor.

#### **▲ Warning**

The mass of this appliance will allow it to move uncontrolled on an inclined surface. Adequate means must be provided to prevent uncontrolled movement at all times.

- Remove the side panels from the unit to make the board connections, Air/CO<sub>2</sub> and Water Regulator gauges accessible.
- Check that board connections are secure and did not vibrate loose during shipment.
- Remove steel top panel. Check that the black chute cover is sitting securely on the chute. The ice maker will not operate properly if it is out of place.
- Check that both micro switches are in line with the motor above the blenders.

**CONNECTIONS**

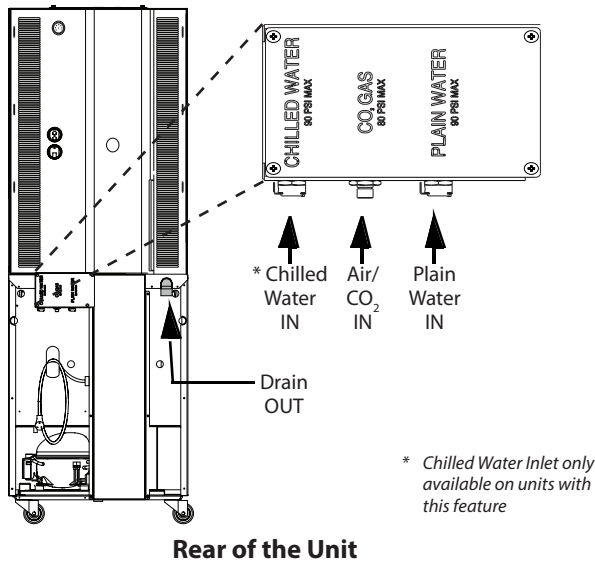

**Important**

Leave enough slack in the water/CO<sub>2</sub>/drain lines to allow access to the rear of the machine without disconnecting the lines.

**Water**

1. Connect the Plain and Chilled (if used) water lines quick disconnect fittings and verify the water regulators are set to 35 psi (241 kPa, 2.41 bar). The Plain Water regulator is located on the left side of the unit and the Chilled Water regulator is located at the rear top. Final during-flow settings will be made once the unit is in operation. See "Start-Up & Cleaning" on page 15.

**Air/CO<sub>2</sub>**

2. Connect Air/CO<sub>2</sub> line quick disconnect fitting. Verify the Air/CO<sub>2</sub> regulator on the left side of the unit is set to 35 psi (241 kPa, 2.41 bar). Final during-flow settings will be made once the unit is in operation.

**Important**

Regulators are factory set but will need to be checked and possibly adjusted under flowing conditions once the unit is operational.

3. Confirm correct orientation of Water and Air/CO<sub>2</sub> fittings.
4. Coil excess tubing and secure with tie straps.

**Drain**

5. Route drain line (minimum 1" ID) to drain, maintaining a 2" (51 mm) air gap. Cut to proper length if needed (do not leave loops in drain). See "Drain Connections" on page 11.

**Electrical**

6. If all electrical and grounding requirements have been followed (See "Electrical" on page 10 & See "Grounding Instructions" on page 10) proceed to insert electrical plug from BIC into wall receptacle.
7. Turn power and compressor switches, on the left-hand side of the unit and the rear, to the ON position.
8. The touch screen should energize and inform the user to perform Zone 2 & 3 cleaning before the unit can be put into operation.

**Important**

Do not add product to the machine until cleaning and sanitizing are complete.

**INSTALLATION CHECKLIST**

Review before proceeding to Start-Up & Cleaning.

- Has all of the internal packing been removed?
- Have all of the electrical, water and CO<sub>2</sub> connections been made?
- Is there proper clearance around the machine for air circulation?
- Is the machine grounded / polarity correct?
- Has the machine been installed where the incoming water temperature will remain in the range of 40°F / 90°F (4°C / 32°C)?
- Have the regulators been set to 35 psi (241 kPa, 2.41 bar)?
- Have the blender door(s) sensor position(s) been checked?
- Have the Compressor and Power switches been turned to the ON position?

**START-UP & CLEANING**

1. Clean and sanitize the Blend-In-Cup machine by following the on-screen instructions.

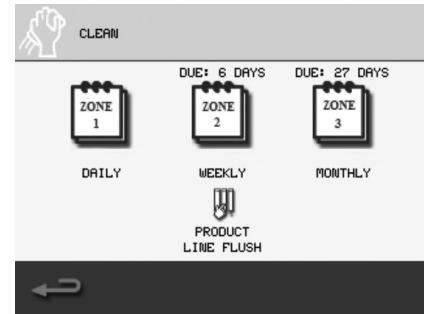

**Cleaning Touch Screen**

See “Weekly Cleaning - Zone 2” on page 40, “Monthly Cleaning - Zone 3” on page 51. By doing so, the following will have been completed:

- A. All beverage lines, ice maker, dispense area, and blender chambers, cleaned and sanitized.
- B. Water run through the drain to verify it is draining properly.
- C. Product bags retrieved from walk-in cooler, installed into the product bins and placed into their proper location in the cabinet. See “Procedure to Install a Product Bag” on page 30 & “Assigning Flavors” on page 26.
- D. All product lines primed and ready for use.

**NOTE:** During the cleaning process is an ideal time to verify pressure regulator settings during flowing conditions.

- E. Verify the Plain Water regulator is set correctly during blend chamber cleaning, the regulator should maintain 35 psi (241 kPa, 2.41 bar) under flowing conditions.
- F. Verify the Air/CO<sub>2</sub> regulator is set correctly during product line cleaning, the regulator should maintain 35 psi (241 kPa, 2.41 bar) under flowing conditions.

**NOTE:** The Chilled Water Regulator needs to be a minimum of 35 psi (241 kPa, 2.41 bar) at no flow conditions.

**Label**

2. Add labels to product bins, put labels in correct place.
3. Add labels anywhere else on the unit required.

**Software**

4. Load recipes. See "Loading Recipes" on page 32.
5. Verify correct drinks and flavors are available.

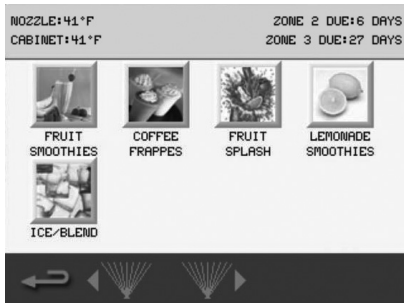
**Drink Selection Screen**

*(Drink choices will vary depending on loaded recipe file)*

**POST INSTALLATION CHECKLIST**

- Has the machine been properly sanitized?
- Has each flavor been installed and primed?
- Have the Air/CO<sub>2</sub> and Plain water regulators been correctly set during flowing conditions?
- Is the machine cycling ON/OFF on the temperature control?
- Has the owner/operator been instructed regarding maintenance procedures?
- Has the owner/operator completed the warranty registration card?

**Calibrate****Important**

Allow cabinet to reach operating temperature 36°F – 38°F (2°C – 3°C) before calibrating. Calibration will be inaccurate if performed above operating temperatures.

6. Product calibration can be performed once operating temperature has been reached. See "Calibration Procedure" on page 27 for step-by-step calibration instructions. Once completed, the Blend-In-Cup machine is ready for use.
7. Reinstall top and side panels.
8. Push BIC into place.
9. Verify the unit is level and shim if necessary.

**DEMONSTRATE**

10. Demonstrate using the Interface. See "Touch Screens" on page 19.
11. Demonstrate how to make drink. See "Procedure to Make a Drink" on page 22.
12. Demonstrate Manager Menu options, using the default password. (The password can be changed.) See "Manager's Menu Screen" on page 25.
13. Set date and time to activate warranty.
14. Complete start-up form, sign, and have store manager sign form. (Fax to number on form.)

# Section 3 Operation

## Component Identification

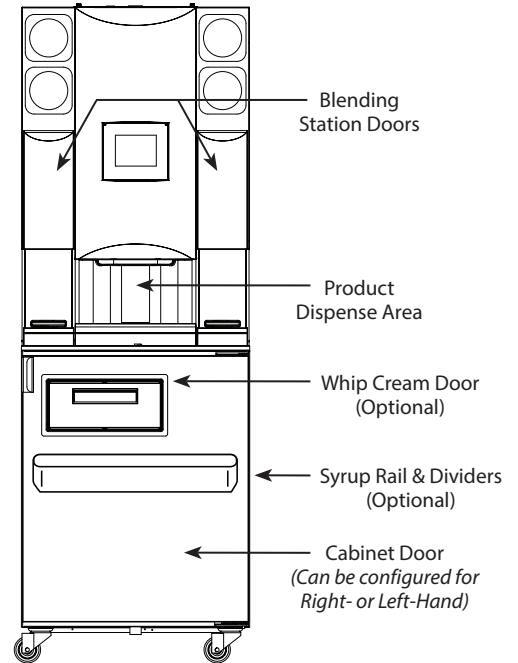
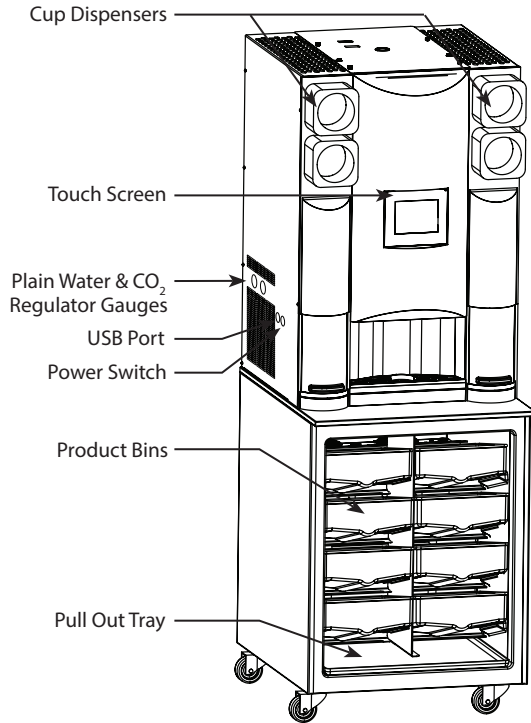

## Sequence of Operation

### NORMAL OPERATION

Drink Selection screen appears after power-up of the unit. Operator presses one of the drink type buttons on the Drink Selection screen, and the Flavor Options screen appears. Once a flavor is selected, the Size screen appears. See "Procedure to Make a Drink" on page 22.

Next the drink preparation sequence commences. If add-ins are required for the drink, the user will be prompted. Here, according to the drink size selected and when initiated through the touch screen, the machine dispenses product and ice into the cup in the dispense area. The cup is then placed into an available blend chamber.

With the blend chamber door closed and after "Start Mixer" is selected on the touch screen, the machine blends the drink for the correct time at the proper blender speed. If add-ins are required for the drink after blending, the user will be prompted.

After the drink is removed and the operator closes the blend chamber door, the automatic rinse of the blender initiates. The Drink Selection screen re-appears.

<b>Default Temperature Control Setting</b>	36°F/2°C set point 2°F/1°C differential controlled by software
--	--

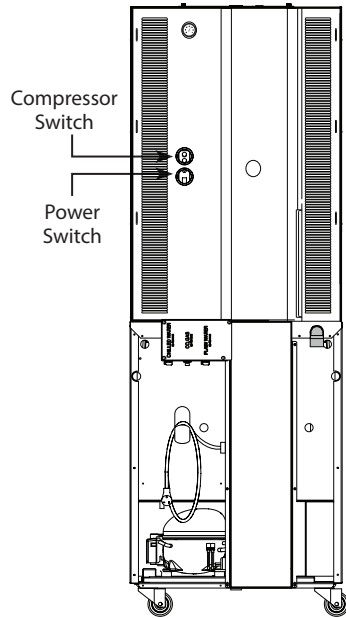
**ICE MAKING****Ice Machine Switches - Rear of the Unit**

The ice machine will not start until:

1. The compressor rocker switch is moved to "ON".
2. Ice does not contact the bin level sensor.
3. The water reservoir is full of water.

With power supplied and the compressor rocker switch in the ON position, the gear motor and refrigeration system start. The float valve controls the water inlet valve and water level. The freeze cycle ends when the ice contacts the ice bin level sensor.

NOTE: Ice machines use an auger to remove ice from the evaporator. Occasional noises (creaks, groans, squeaks, or pops) are a normal part of the ice making process.

## Touch Screens

The “easy ToUCH” screen has four selections. One is for the drink making procedure: Drink Selection displays by default at start-up. The Manager’s Menu is for accessing the machine’s settings. Inventory is for product information and Cleaning is for routine maintenance of the machine.

### DRINK SELECTION SCREEN

The Drink Selection screen appears on power-up (except where clean/sanitize limitations have been exceeded, in which case the Cleaning screen appears). See “Maintenance” on page 33 for Daily, Weekly and Monthly cleaning/sanitization. The Drink Selection screen’s primary function is to select a drink to make or to access the Main Menu.

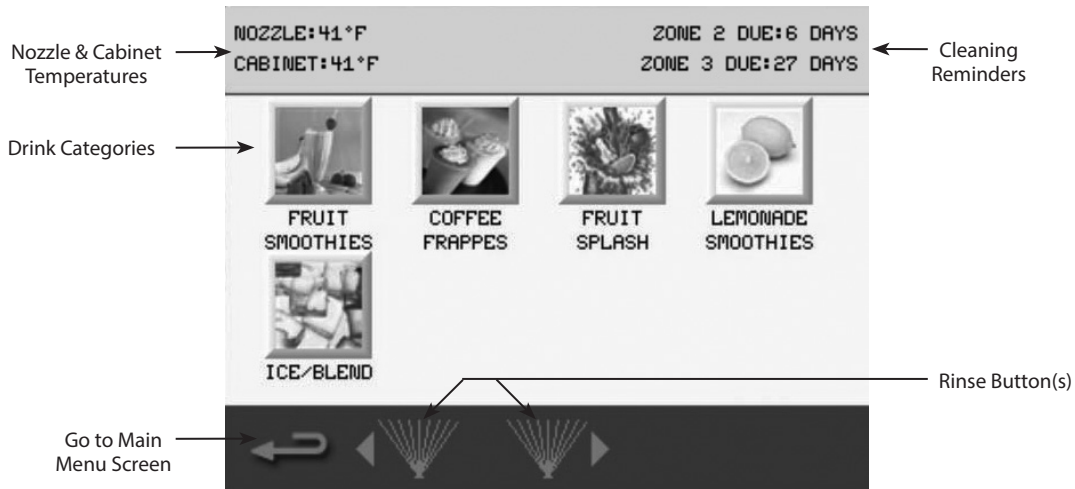

### How to Access

The Drink Selection screen displays by default unless cleaning is required. This screen can also be accessed through the main menu Book Icon.

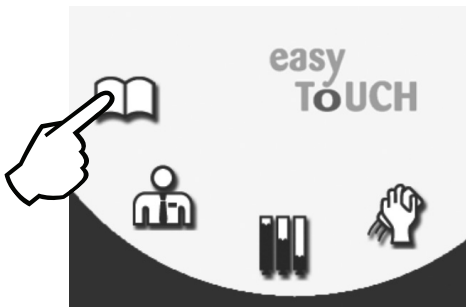

### Icon Button Descriptions

- NOZZLE & CABINET Temperatures**  
 Displays the current temperature for dispense point nozzle and the refrigeration cabinet. Unit of measure can be changed in the Manager’s Menu.
- Drink Categories**  
 The main product categories are displayed left to right on the Drink Selection screen. Touching a category will display the drink flavor options available for the category.  
 NOTE: Available drink selections may vary depending on the recipe file installed.
- Main Menu Arrow**  
 Navigates to the Main Menu screen.  
 (See “Main Menu Screen” on page 24)
- Cleaning Reminders**  
 Displays the time remaining in days until ZONE 2 (Weekly) and ZONE 3\* (Monthly) cleaning is required.  
*\* If equipped with this feature.*
- Rinse Button**  
 Press to rinse the left or right blender chambers. Blend chamber door(s) must be closed.

**FLAVOR SELECTION SCREEN**

The Flavor Selection screen appears after a Drink Selection has been made. Flavor options will vary depending on what recipes are configured on the unit. This screen's primary function is to select a drink flavor.

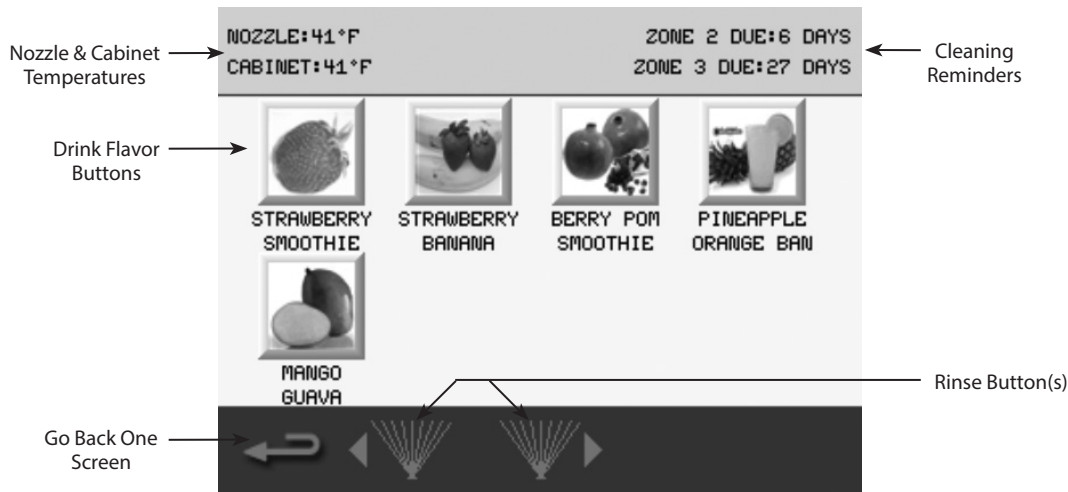

**How to Access**

The Flavor Selection screen displays after a drink selection has been made from the Drink Selection screen.

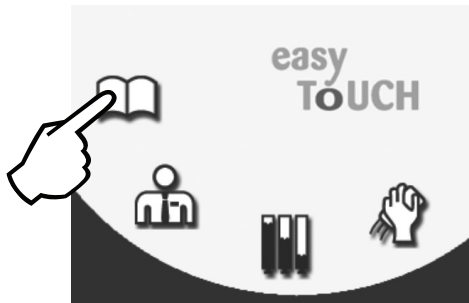

**Icon Button Descriptions**

- **NOZZLE & CABINET Temperatures**  
Displays the current temperature for dispense point nozzle and the refrigeration cabinet. Unit of measure can be changed in the Manager's Menu.

- **Drink Flavor Buttons**  
Flavor choices for the drink type that was selected.
  - **Yellow Border**  
If any of the drink's ingredients will expire soon, the yogurt has expired, or there is less than 10% left in the product bag. Check the Product Inventory Screen for exact amount of product remaining. (See "Product Inventory Screen" on page 29)
  - **Red Border**  
Product expired, flavor selection unavailable. Will need to replace product bag. (See "Procedure to Install a Product Bag" on page 30)
- NOTE: Available flavor selections may vary depending on the recipe file installed.
- **Back Arrow**  
Navigates to previous Drink Selection screen. (See "Drink Selection Screen" on page 19)
- **Cleaning Reminders**  
Displays the time remaining in days until ZONE 2 (Weekly) and ZONE 3\* (Monthly) cleaning is required. \* If equipped with this feature.
- **Rinse Button**  
Press to rinse the left or right blender chambers. Blend chamber door(s) must be closed.

**SIZE SCREEN**

The Size screen appears after a drink flavor has been chosen from the Flavor Selection screen. This screen’s primary function is to select size and make a drink. Optional Add-Ins are also performed through this screen if the drink requires them.

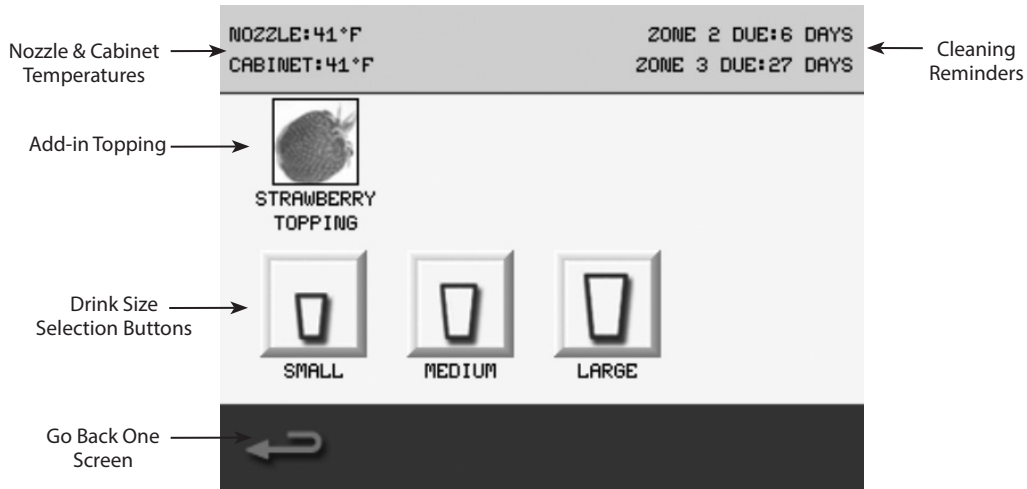

**Icon Button Descriptions**

- **NOZZLE & CABINET Temperatures**  
Displays the current temperature for dispense point nozzle and the refrigeration cabinet. Unit of measure can be changed in the Manager’s Menu.
- **Add-Ins**  
These are not functioning buttons, only a graphic representation of the add-in used when making the selected drink. The screen will prompt the user when the add-in is to be added to the drink.  
NOTE: Not all drinks have an add-in. Drink add-ins may vary depending on the recipe file installed.
- **Drink Size Buttons**  
Press a drink size (SMALL, MEDIUM, or LARGE) to start the drink making process. Once one is selected, the screen will prompt the user to place the correct cup size in the dispense area.

With the correct cup in place, press the green check to dispense product/ice into the cup or press the red X to cancel and return to the Size Selection screen. (See “Procedure to Make a Drink” on page 22)

- **Back Arrow**  
Navigates to previous Flavor Selection screen. (See “Flavor Selection Screen” on page 20)
- **Cleaning Reminders**  
Displays the time remaining in days until ZONE 2 (Weekly) and ZONE 3\* (Monthly) cleaning is required.  
*\* If equipped with this feature.*

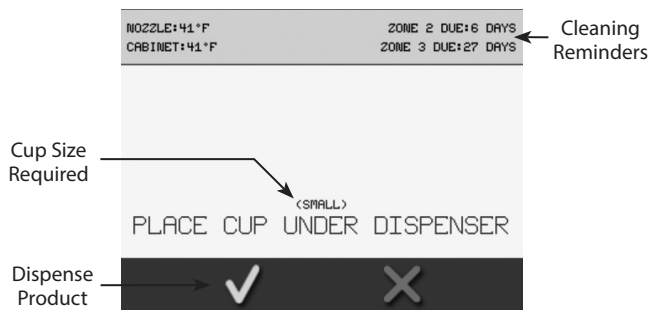

**Dispense Prompt Screen**

**Procedure to Make a Drink**

NOTE: Ice must be present in the ice hopper, product must be connected and primed to produce a drink.

1. Press the Open Book icon.

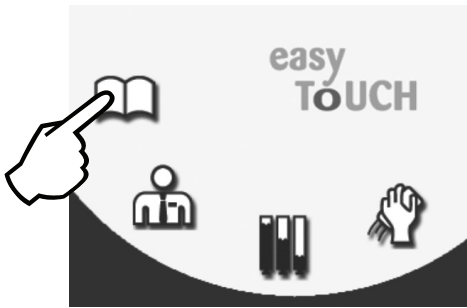

2. Select a category of drink recipes.

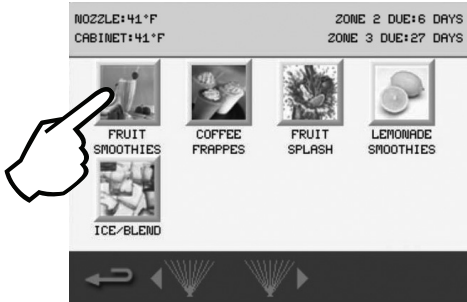

3. Specific drink combinations are displayed on the next screen. If a drink is not available, it will be highlighted with a red square around it. Unavailable flavors have expired and will need to be replaced. (See "Procedure to Install a Product Bag" on page 30)

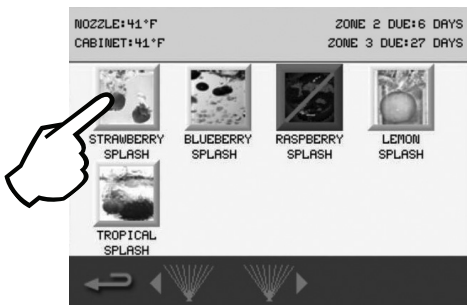

4. Drink size is the next selection.

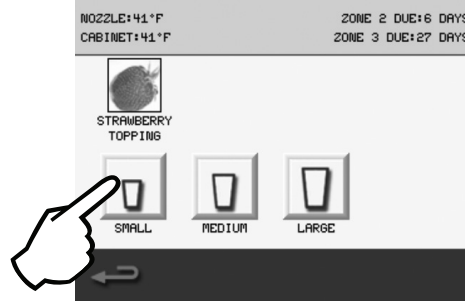

5. Place cup under center dispenser and press the green check.

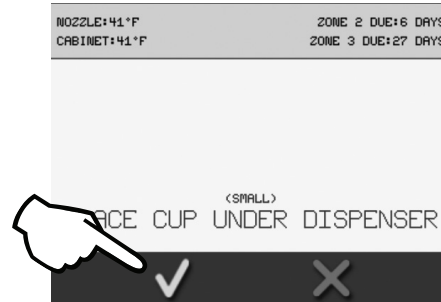

6. As the flavor dispenses into the cup, the screen will display DISPENSING.
7. If Add-in ingredients need to be manually added, the screen will give specific directions. More ingredients may be required later, follow the screen directions.
8. Choose an available mixer, place the cup into the blender chamber, and shut the door. Press the corresponding right or left flashing green/blue arrow.



NOTE: Single mixer unit will only display a right arrow. Press the red X to cancel.

9. While the drink is mixing, the top of the screen will read BLENDING.

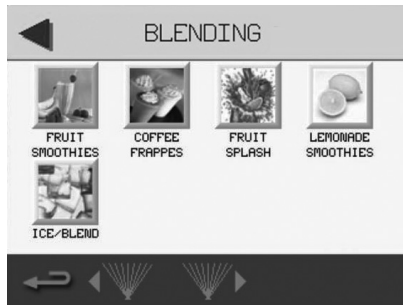

NOTE: On dual mixer units, a second drink can be selected and blended simultaneously.

10. Follow all drink specific screen directions for add-ins if necessary and press the flashing arrow if prompted.



11. When the blender is done mixing, open the door and remove the drink. The blending station will go through a rinse cycle after the door is closed again.
12. The blend station will not be available again until the door is closed and the rinse cycle is completed.

**MAIN MENU SCREEN**

Accessed primarily through the Drink Selection screen, this screen's primary function is to provide access to all other procedures and adjustments that can be performed on the unit.

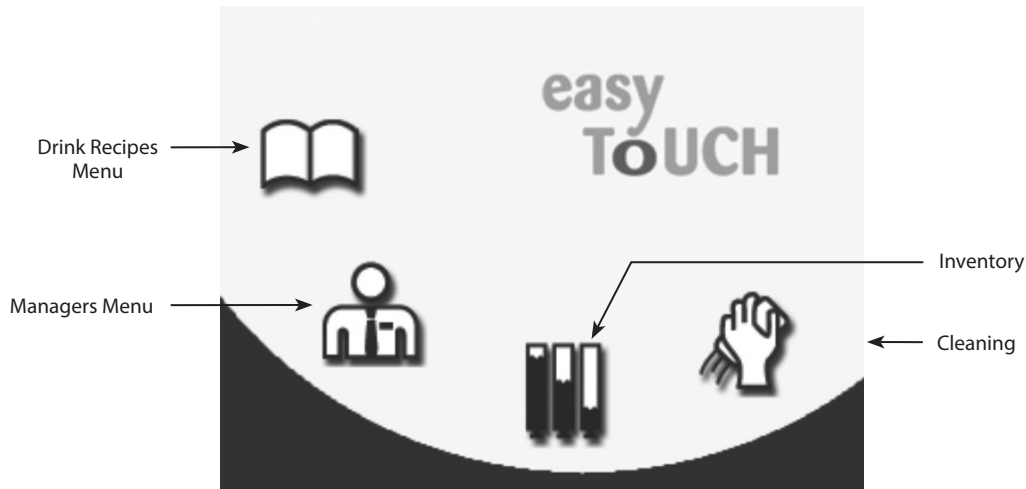

**Category Icon Descriptions**

• **Drink Recipes Menu**

Displays the Drink Selection screen. (See "Drink Selection Screen" on page 19)

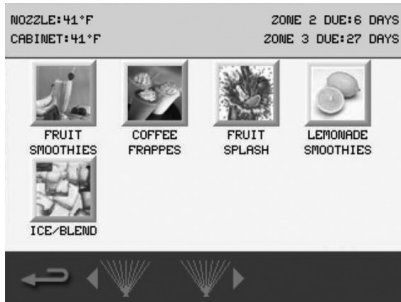

• **Managers Menu**

Displays a Password Keypad screen. When password is correctly entered, a menu of protected information for a manager will display. (See "Manager's Menu Screen" on page 25)

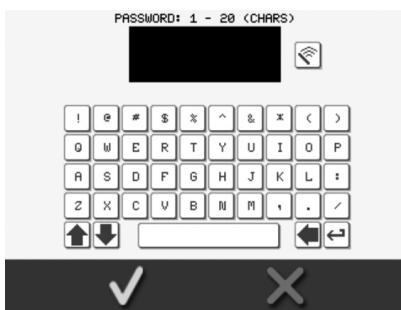

• **Inventory**

Displays the remaining percentage of product in each bag, and NOZZLE and CABINET temperature readings. (See "Product Inventory Screen" on page 29)

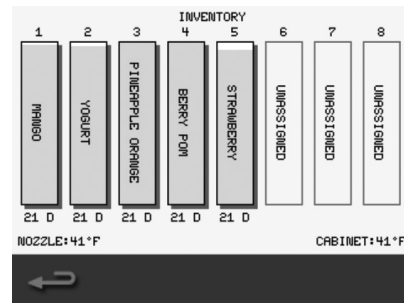

• **Cleaning**

Displays the Cleaning screen and gives the options for ZONE 1 (Daily), ZONE 2 (Weekly), or ZONE 3\* (Monthly) cleaning and PRODUCT LINE FLUSH. (See "Maintenance" on page 33) \* If equipped with this feature.

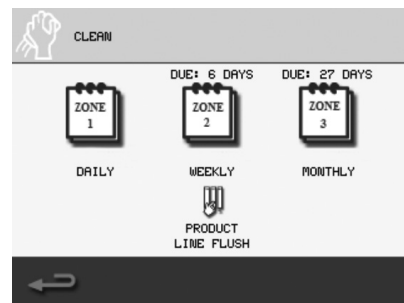

### MANAGER'S MENU SCREEN

Accessed through the Main Menu screen, this screen's primary function is to provide on-screen access to Manager-only functions.

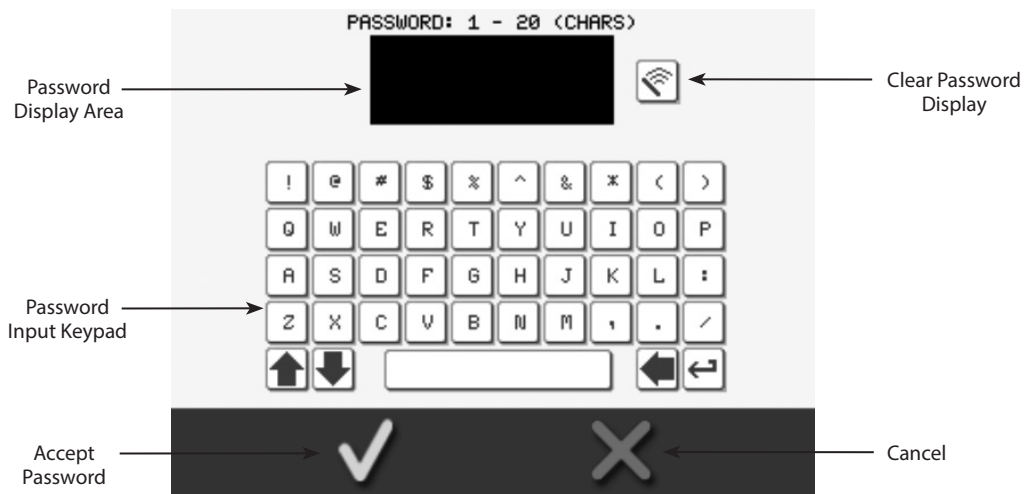

#### How to Access

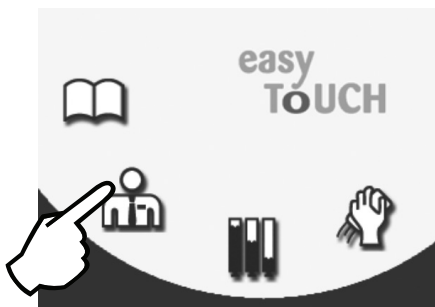

After selecting Manager's Menu icon from the Main Menu, the Password Keypad screen appears. The manager screens are password protected. Enter the Manager's pass code using the QWERTY keypad, then press the green check to accept.

After typing in the correct password, Language, Date/Time, Temperatures, Edit Password, Configure Slots, Updates, Auto Wash Timer and Service screens are accessible. When the manager screens are inactive for a time period, the screen will return to the drink menu.

**Important**

Do not change the language, edit the password or configure the slots unless instructed to do so by the factory. The service screen is password protected, contact the factory for access.

#### Manager Menu Features

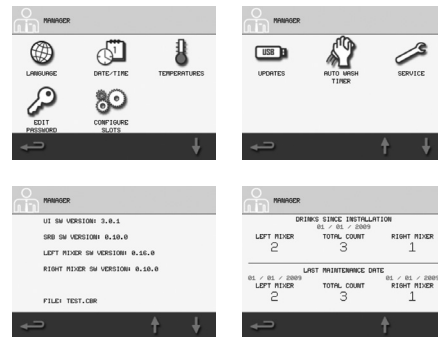

**Manager Menu Screens**

- **Manager Screen 1**
  - LANGUAGE
  - DATE & TIME Settings
  - TEMPERATURES
  - EDIT PASSWORD
  - CONFIGURE SLOTS
- **Manager Screen 2**
  - UPDATES
  - AUTO WASH TIMER
  - SERVICE (Password Protected Sub Screens)
- **Manager Screen 3**  
This screen displays all current software versions on the unit.
- **Manager Screen 4**  
This screen displays the drink counter.

**Assigning Flavors**

1. From the Main Menu select the Manager icon.

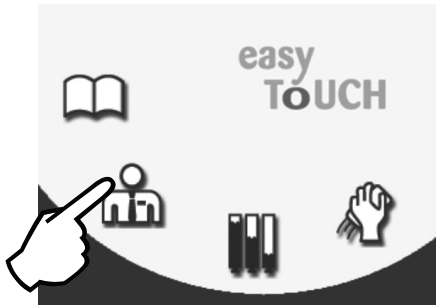

2. Type in the password.



3. Select the green check.

4. Select CONFIGURE SLOTS.

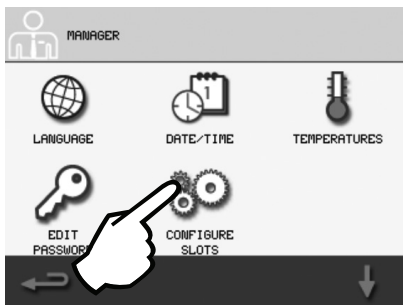

5. Press the SLOT FLAVOR icon.

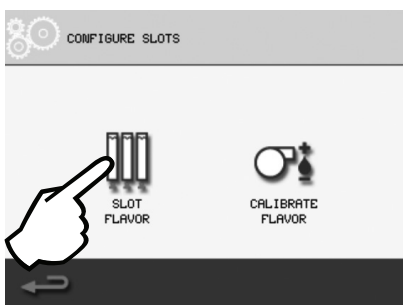

6. Select a slot you want to assign a flavor to.

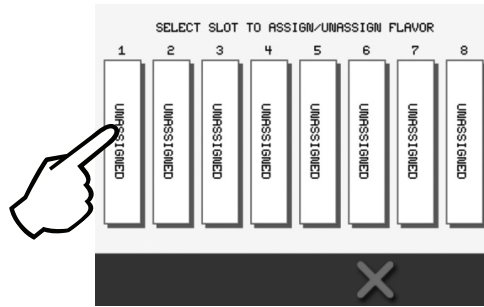

7. Select from available flavors.

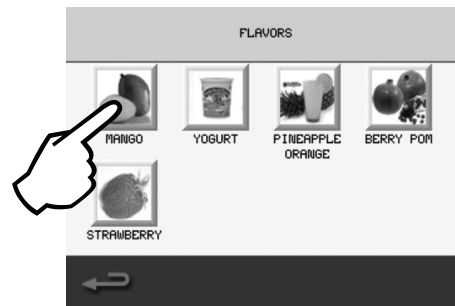

NOTE: Available flavors will vary depending on the recipe file that is loaded on the machine. Select ASSIGN FLAVOR.

- Screen will return to the Select Slot screen.
- The flavor name will now display and the slot will be highlighted green.

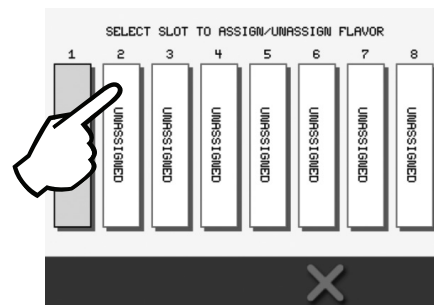

8. Continue to select slots and flavors until all slots are assigned.



9. Select the red X when finished to return to the Configure Slots screen. Select the return arrow twice to return to the Main Menu.

**CALIBRATION PROCEDURE**

**Gather the following supplies**

<b>Important</b>	
Prior to performing calibration, check for empty product bags, refrigerate product bags for 24 hours, and if Zone 2 cleaning has just been completed, wait 1 hour.	
<b>Kitchen Scale</b>	
<b>Empty &amp; Clean Cups</b>	

1. From the Main Menu, select the Manager icon.

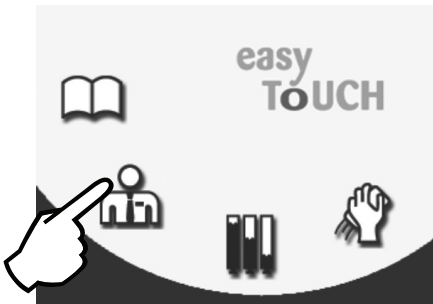

2. Enter the manager's password.
3. Select CONFIGURE SLOTS.

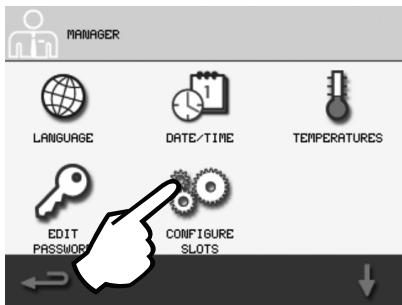

4. Select CALIBRATE FLAVOR.

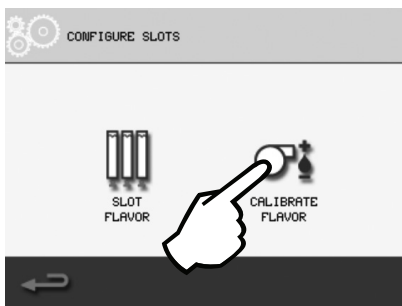

5. Select a flavor, water or ice to calibrate.

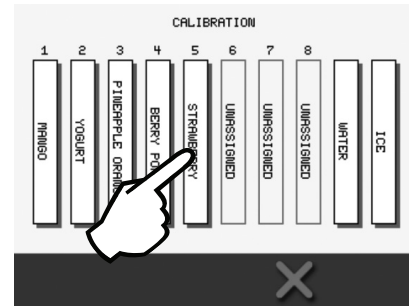

6. Follow the on-screen instructions and do the following:
  - Get a scale.
  - Tare empty cup weight.
  - Position an empty cup for dispense.

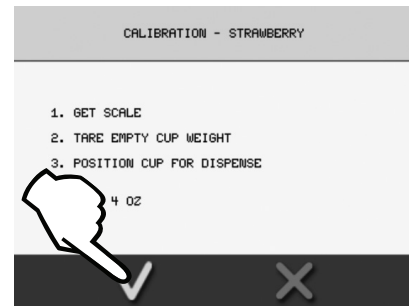

- Press green check when ready.
  - Wait until dispensing is done.
  - Weigh cup.

NOTE: Flavor and water target is 4 oz. (113 grams). Ice target is 6 oz. (170 grams).

- Tap button to enter weight.

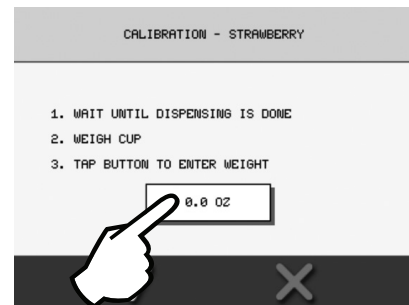

7. The Enter Weight screen will appear.

A. Enter the cup weight using the number pad.

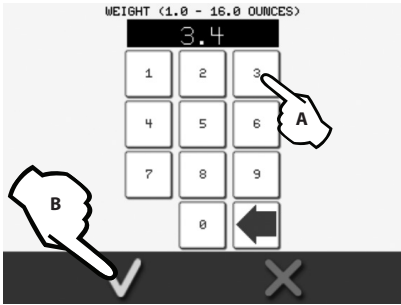

B. Select the green check when done to continue.

NOTE: If the weight entered was not 4 oz. (113 grams) for a flavor/water or 6 oz. (170 grams) for ice, the unit will electronically adjust the dispense calibration based on the weight entered to obtain the correct target dispense weight. No mechanical adjustments are required.

8. The calibration screen will display again with the weight entered on the previous screen.

A. If the weight displayed is incorrect, press the button again and re-enter weight.

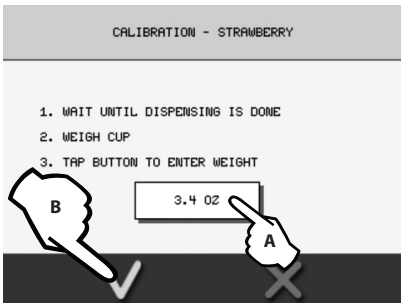

B. Press green check when done to save and complete calibration for the slot.

9. The CALIBRATION COMPLETE screen will display.

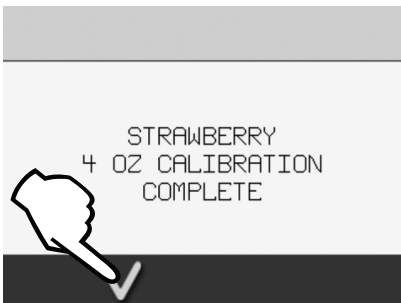

- Press green check to return to the Calibration Slot Choice screen.

10. The newly calibrated slot will be highlighted in green.

A. Choose another flavor, water or ice to calibrate.

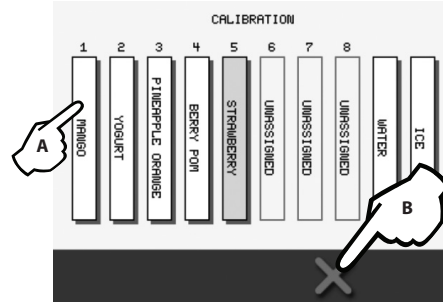

B. Or press the red X to return to the CONFIGURE SLOTS Screen. From there press the back arrow twice to reach the Main Menu and place the unit into operation.

**PRODUCT INVENTORY SCREEN**

This screen's primary function is to provide visual product inventory information for the user. The Product Inventory screen is normally accessed through the Main Menu.

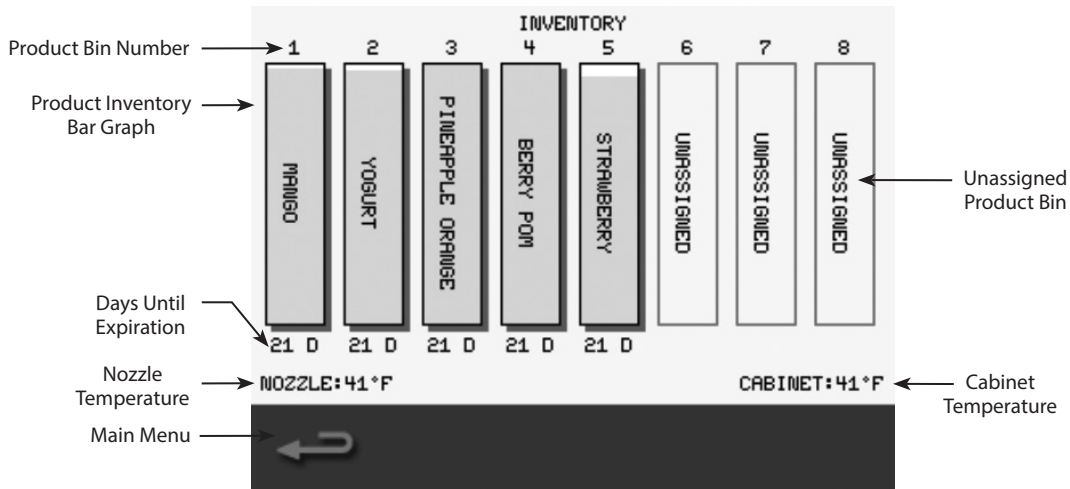

The inventory screen visually displays levels for all flavors. Underneath each flavor is the time remaining until the flavor expires in days. NOZZLE and CABINET temperatures are also on the inventory screen. When a flavor is touched on the screen, the instructions to replace a product bag will begin. (See "Procedure to Install a Product Bag" on page 30)

**How to Access**



**Icon Button Descriptions**

- **Product Bin Number**  
Displays the product bin number the Product Inventory Bar Graph represents.
- **Product Inventory Bar Graph**  
Product inventory tracking estimates the remaining flavoring in each product's bag in the reach-in compartment in 5% increments.
  - **Green Bar**  
Product inventory is above 10% and not near expiration.
  - **Yellow Bar**  
Product inventory has fallen below 10% or less than 24 hours until expiration, a message appears on the Drink Selection screen for the affected drink(s).
  - **Red Bar**  
If the bar representing a product's inventory level is red, the bag is empty or expired. Replace product. (See "Procedure to Install a Product Bag" on page 30)

• **UNASSIGNED**

If UNASSIGNED is displayed below the product bin number, no product is currently assigned to the bin.

• **NOZZLE Temperature**

Displays the current temperature near the dispense point. Can be set to Celsius or Fahrenheit in the Manager's Menu. (See "Manager's Menu Screen" on page 25)

• **Back Arrow**

Navigates to previous Main Menu screen.

• **Days Until Expiration**

Displays the number of days remaining until the product bag expires. Pressing the corresponding product bar graph will access the Replace Product screen, displaying the steps to follow for replacement. (See "Procedure to Install a Product Bag" on page 30)

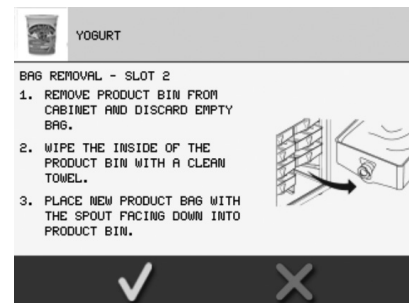

**CABINET Temperature**

Displays the current temperature in the refrigeration cabinet. Can be set to Celsius or Fahrenheit in the Manager's Menu. (See "Manager's Menu Screen" on page 25)

**Procedure to Install a Product Bag**

1. From the Main Menu touch the Inventory icon.



2. On the Inventory screen, select the product to be installed.

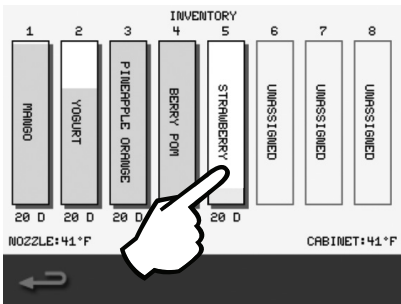

- Products with less than 10% inventory or less than 24 hours until product expires will be displayed with a yellow bar.
- Products that are expired will be displayed with a red bar.

3. Follow the on screen instructions.

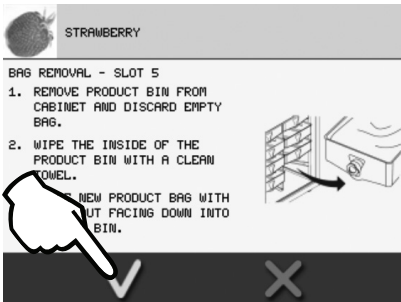

- Remove product bin from cabinet and discard empty bag.
- Wipe the inside of the product bin with a clean towel.
- Place new product bag with the spout facing down into product bin.

4. Press the green check to continue.
5. Position rear groove of the spout on product bag into slot of the product bin.

**Important**

The spout must snap into the slot of the product bin!

6. Open the cap on the product bag and tear it off.
7. Return product bin to its position in cabinet.
8. Press the green check to continue.
9. Select inventory level from FULL BAG, PRIME FLAVOR or NO BAG.

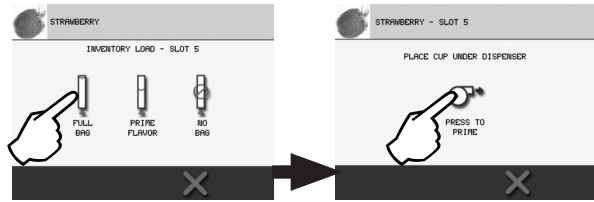

10. Select FULL BAG when installing a new product bag and the Prime screen will display.
11. Place cup under dispenser and press the Prime icon to prime the line with the new product bag, DISPENSING will display on the screen. Repeat until product consistently flows into the cup.
12. Press the green check to continue.

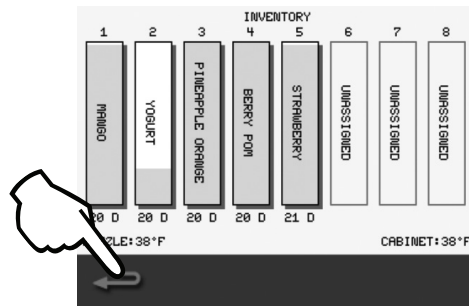

13. Installation is now complete. The inventory bar will now display full, green, and days until expiration will reset.
14. Select another product to be installed or return to the previously active screen by pressing the back arrow.

**Important**

Resetting a product's inventory without replacing the product bag will cause the Product Inventory screen, percentages, and expiration to be inaccurate.

### CLEANING SCREEN

The Cleaning screen appears after selected from the Main Menu or when prompted to perform routine cleaning. This screen's primary function is to perform routine cleaning and sanitation of the machine.

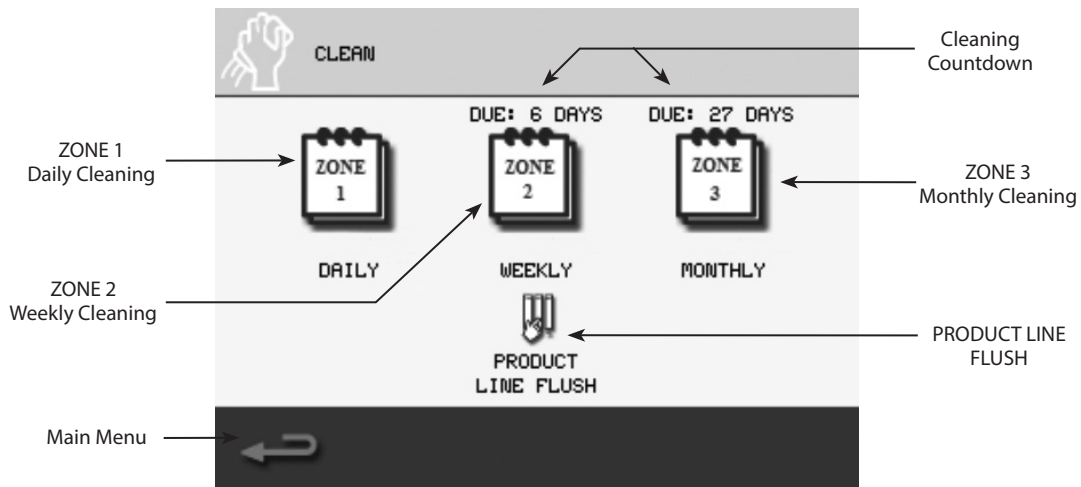

#### How to Access



#### Icon Button Descriptions

- **ZONE 1 - Daily Cleaning**  
Displays the Daily Cleaning screen and guides the user through all daily cleaning requirements. See "Daily Cleaning - Zone 1" on page 35.
- **ZONE 2 - Weekly Cleaning**  
Displays the Weekly Cleaning screen and guides the user through all weekly cleaning requirements. See "Weekly Cleaning - Zone 2" on page 40.
- **ZONE 3 - Monthly Cleaning\***  
Displays the Monthly Cleaning screen and guides the user through all monthly cleaning requirements. See "Monthly Cleaning - Zone 3" on page 51.  
\*If equipped with this feature.
- **Back Arrow**  
Returns to the previous screen or Main Menu.
- **Cleaning Count Down**  
Days left until Cleaning is required. Shown in DAY increments, changes to HOURS when there is less than a day (24 hours) until cleaning of the machine is required. Resets once cleaning has been completely performed.

#### Important

Once the time limit has been exceeded the machine will no longer make a drink until cleaning has been completed.

- **PRODUCT LINE FLUSH**  
Displays the Product Line Flush screen and guides the user on how to flush all product lines. See "Product Line Flush" on page 66.

## Other Operations

### LOADING RECIPES

Plug in the Flash drive (above upper left corner of screen). From the Main Menu select the Manager icon. Type in the password and select the green check. Select the down arrow to navigate to the next screen. Select UPDATES. Select RECIPES. Select the UPDATE RECIPES FROM USB icon. Verify the version to be loaded is correct, and select the green check. Screen will display status and then UPDATE COMPLETE.

### RECOMMENDED CUPS

Although a variety of cups may work in the BIC machine, the most success (without cup cracking) has come from polyethylene (PETE) cups. Other varieties such as glass, polypropylene, and thick walled styrofoam have also proven workable. Cup thickness, material composition, diameter and cup height play an important role in the workability of the cup within the machine.

The following are cup general guidelines. Cups outside these parameters may work but are not recommended. Testing in the machine with the product will be necessary. Contact the Multiplex team for a detailed cup evaluation.

- Cup heights between 4.25" and 7.00".
- Cup opening diameter greater than 3.50" and less than 4.18".
- Cup base diameter greater than 2.38" and less than 2.62".
- Approved Materials - PET, PET-R, Glass & Metal

### Changing the Cup Dispenser Size

Turn the inner dial so that the notch sets at 1, 2, 3 or 4. Setting 1 will hold the smallest cup and 4 the largest cup. When the dial moves from 1 to 2, the dispenser fingers retract and allow for a larger cup to be inserted.

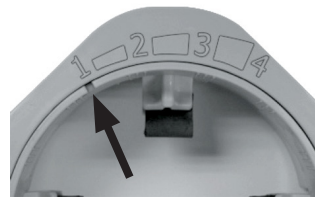
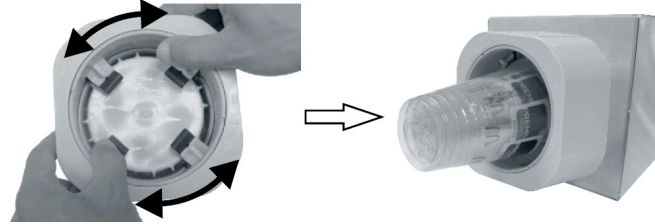

Position 1

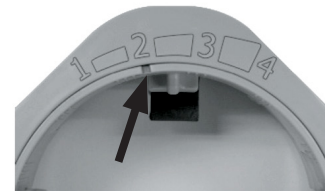

Position 2

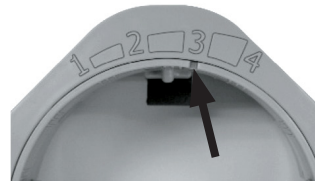

Position 3

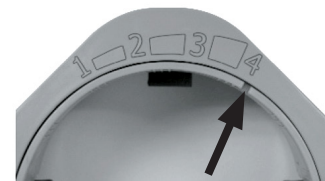

Position 4

## Section 4 Maintenance

### General Maintenance

This section covers common unit components and their care.

The chart below is an overview of the maintenance that the end user and service technician should perform, and

the frequency. These figures are the minimum required. If the Ice Machine is supplied with hard water, more frequent cleaning should be performed. If the condenser air filter is totally blocked after one week, more frequent cleaning is recommended. (X = End User, S = Service Company)

Maintenance	Daily	Weekly	Monthly	3 Months	6 Months	Annual	After Prolonged Shutdown	At Start-Up
Blender / Dispense Area Cleaning/ Sanitizing (Zone 1 Cleaning)	X							
Product Line Cleaning & Sanitizing (Zone 2 Cleaning)		X					X	S
Drain Cleaning		X					X	
Clean Air Filters			X				X	
Clean/Sanitize Ice Maker/Bin (Zone 3 Cleaning)			X				X	S
Descale Ice Maker/Bin (Zone 3 Cleaning)					S		S	
Clean Condenser Coil				X			X	
Inspect Ice Maker / Dispenser Parts						S	S	S
Check Ice Quality	X	X				S	S	S

#### ⚠ Warning

The power switch must be turned to OFF and the unit disconnected from the power source whenever performing service, maintenance functions or cleaning the refrigerated area

#### Important

If the machine going to be shut down for any length of time, it is recommended to go through the Zone 2 - Weekly Cleaning both prior to turning off the unit and when returned to use.

If the unit is turned off, the product will no longer be kept cool in the refrigeration cabinet. Remove all product bags and keep refrigerated to prevent spoilage.

### DOOR GASKET MAINTENANCE

Door gaskets require regular cleaning to prevent mold and mildew buildup and also to retain the elasticity of the gasket. Gasket cleaning can be done with the use of warm soapy water. Avoid full strength cleaning products

on gaskets as this can cause them to become brittle and crack. Never use sharp tools or knives to scrape or clean the gasket. Gaskets can be easily replaced and do not require the use of tools or an authorized service person. The gaskets are "Dart" style and can be pulled out of the groove in the door and new gaskets can be "pressed" back into place.

### DRAIN MAINTENANCE - INSIDE LOWER CABINET

Each unit has a drain located inside the unit that removes the condensation from the evaporator coil and routes it to an external condensate evaporator pan. Each drain can become loose or disconnected during normal use. If you notice water accumulation on the inside of the unit, be sure the drain tube is connected to the evaporator drain pan. If water is collecting underneath the unit, make sure the end of the drain tube is in the condensate evaporator in the machine compartment. The leveling of the unit is important, as the units are designed to drain properly when level. Be sure all drain lines are free of obstructions.

**REFRIGERATORS****⚠ Warning**

Do not damage the refrigeration circuit when installing, maintaining or servicing the unit.

The interior and exterior can be cleaned using soap and warm water. If this isn't sufficient, try ammonia and water or a nonabrasive liquid cleaner. When cleaning the exterior, always rub with the "grain" of the stainless steel to avoid marring the finish. Do not use an abrasive cleaner because it will scratch the stainless steel and can damage the breaker strips and gaskets.

**STAINLESS STEEL CARE & CLEANING**

To prevent discoloration or rust on stainless steel, several important steps need to be taken. First, we need to understand the properties of stainless steel. Stainless steel contains 70-80% iron, which will rust. It also contains 12-30% chromium, which forms an invisible passive film over the steel's surface, which acts as a shield against corrosion. As long as the protective layer is intact, the metal is still stainless. If the film is broken or contaminated, outside elements can begin to break down the steel and begin to form discoloration or rust. Proper cleaning of stainless steel requires soft cloths or plastic scouring pads!

**⚠ Warning**

Never Use Steel Pads, Wire Brushes or Scrapers!

Cleaning solutions need to be alkaline-based or non-chloride cleaners. Any cleaner containing chlorides will damage the protective film of the stainless steel. Chlorides are also commonly found in hard water, salts, and household and industrial cleaners. If cleaners containing chlorides are used, be sure to rinse repeatedly and dry thoroughly. Routine cleaning of stainless steel can be done with soap and water. Extreme stains or grease should be cleaned with a non-abrasive cleaner and plastic scrub pad. Always rub with the grain of the steel. There are stainless steel cleaners available which can restore and preserve the finish of the steel's protective layer. Early signs of stainless steel breakdown are small pits and cracks. If this has begun, clean thoroughly and start to apply stainless steel cleaners in attempt to restore the passivity of the steel.

**⚠ Caution**

Never use an acid-based cleaning solution! Many food products have an acidic content, which can deteriorate the finish. Be sure to clean the stainless steel surfaces of ALL food products. Common items include: tomatoes, peppers and other vegetables.

**DOORS/HINGES**

Over time and with heavy use, doors and hinges may become loose. If this happens, tighten the screws that mount the hinge brackets to the frame of the unit. Loose or sagging doors can cause the hinges to pull out of the frame, which may damage both the doors and the hinges. In some cases this may require qualified service agents or maintenance personnel to perform repairs.

NOTE: Do not place hot pans on/against the blue ABS liner. Do not throw items into the storage area. Failure to follow these recommendations could result in damage to the interior of the cabinet or to the blower coil. Overloading the storage area, restricting the airflow, and continuous opening and closing of the doors and drawers will hamper the unit's ability to maintain operational temperature.

**PREVENTING BLOWER COIL CORROSION**

Immediately wipe up all spills.

### Daily Cleaning - Zone 1

NOTE: The following procedures are the basic daily cleaning instructions, on-screen instructions can vary depending on the recipe that was created with the MenuConnect program. *\* These items are optional and may not be displayed on all easyToUCH screens during ZONE 1 Cleaning.*

- Time to complete - 15 minutes

1. Cycle touch screen to the Main Menu and select the Cleaning icon.



2. In the Cleaning screen select the ZONE 1 icon.

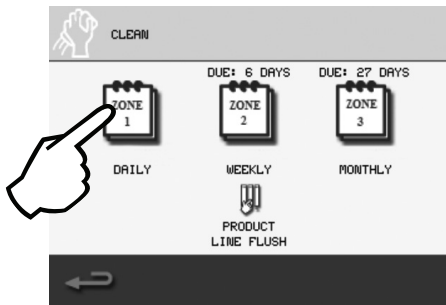

### GATHER THE FOLLOWING SUPPLIES

Follow the on-screen instructions and gather the following supplies:

<b>Clean towels (Cloths*)</b>	
<b>Spray Cleaner &amp; Detergent Solution</b> (Approved dish detergent solution)	
<b>Spray Sanitizer &amp; Solution</b> (Approved sanitizer solution that provides 100 ppm available chlorine.)	
<b>Red &amp; Blue Cleaning Cups</b> (1 of each per blender station)	
<b>Cleaning Brush, Gloves &amp; Safety Glasses*</b>	
<i>* These items are optional and may not be displayed on all easyToUCH screens.</i>	

NOTE: If other cleaners are used, it is possible they will not clean or sanitize your machine to NSF standards.

- Press the down arrow to continue.

**BLENDERS / DISPENSE AREA CLEANING & SANITIZING****Grate Removal / Blender Station Wash**

Follow the on screen instructions:

1. Put on gloves and safety glasses.\*
2. Remove grate from the mixer station(s).
  - Press the down arrow to continue.

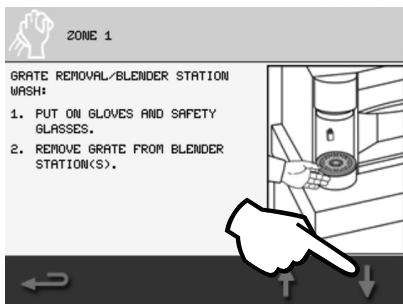

3. Spray all surfaces inside blender station with cleaning solution. Then scrub thoroughly with approved cleaning brush.\*
4. Thoroughly wipe down all surfaces of mixer station and repeat for the other side if applicable.
  - Press the down arrow to continue.

**Dispensing Area Cleaning**

1. Remove center grate from dispensing area.

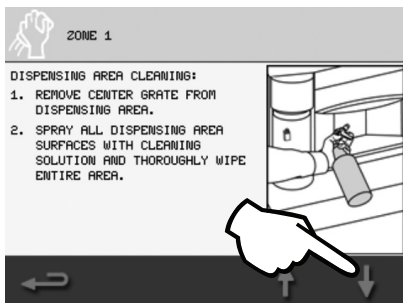

2. Spray all dispensing area surfaces with cleaning solution. Then use approved cleaning brush to thoroughly scrub area.\*
  - Press the down arrow to continue.
3. Thoroughly spray each individual dispense nozzle with cleaning solution and apply cleaner to each individual dispensing valve. Then use approved cleaning brush to carefully scrub area.\*
4. Thoroughly wipe all dispense valves and dispense area with a clean towel.
  - Press the down arrow to continue.

**Mixer Door Removal**

1. Slightly open mixer door.

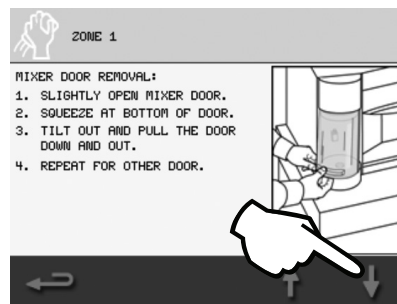

2. Squeeze at bottom of door.
3. Tilt out and pull the door down and out.
4. Repeat for other door if applicable.
  - Press the down arrow to continue.

**Blender Station Wash**

1. Completely spray blender station with cleaning solution. Use cleaning brush to thoroughly scrub down the entire area.\*

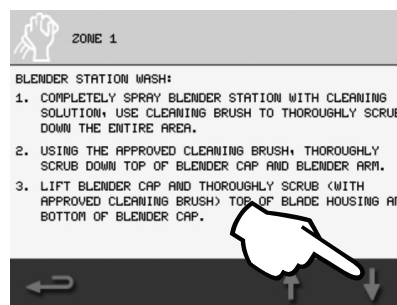

2. Using the approved cleaning brush, thoroughly scrub down top of blender cap and blender arm.\*
3. Lift blender cap and thoroughly scrub (with the approved cleaning brush) top of blade housing and bottom of blender cap.\*
  - Press the down arrow to continue.
4. Thoroughly spray with sanitizer solution.
5. Using the approved cleaning brush, scrub entire blender assembly.\*
6. Repeat for other side if applicable.
  - Press the down arrow to continue.

**Reinstall Grate(s)/Door(s)**

1. Take all grate(s) and door(s) to sink to wash and sanitize.

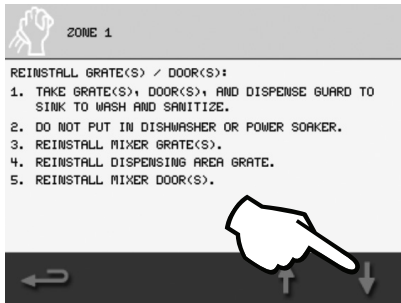

**Important**

Never Use Steel Pads, Wire Brushes, Scrapers, or any Abrasive Cleaners / Scouring Pads!

2. Do not put in dishwasher or power soaker.
3. Reinstall mixer grate(s).
4. Reinstall dispensing area grate.
5. Reinstall mixer door(s)
  - Press the down arrow to continue.

**Blender Wash**

1. Place blue cleaning cup(s) with wash solution in blender station(s) and close the blender doors.
  - Use approved dish detergent solution.

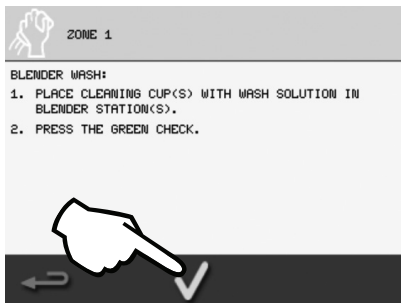

2. Press the green check to begin.

The blenders will lower into the wash solution and spin to clean. WASHING will display on the screen.

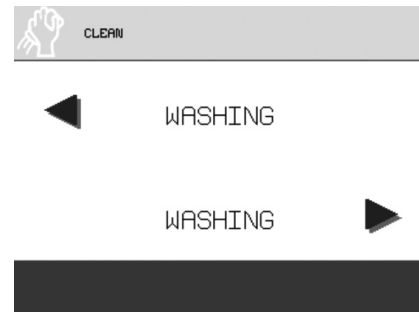

Follow the on screen instruction. When prompted REMOVE CUP, remove the blue cup(s) and pour wash solution down the drain.



Close the blender door(s) and RINSING will display on the screen while the machine rinses the blenders.

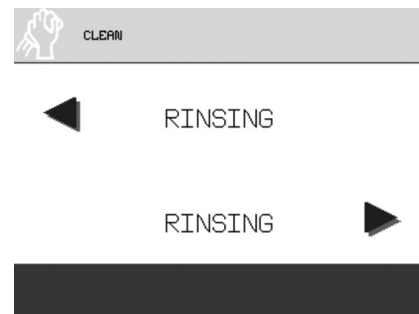

FINISHED will display on the screen, then progress to the Blender Sanitizing screen.

**Blender Sanitizing**

1. Place red sanitizing cup(s) with sanitizing solution in blender station(s) and close the blender doors.
  - Use approved sanitizer solution that provides 100 ppm available chlorine.

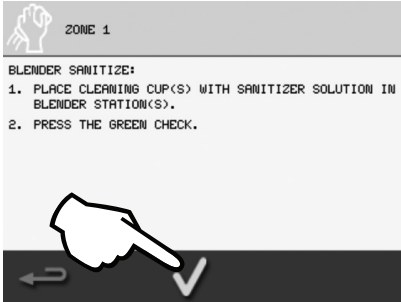

2. Press the green check to begin.

The blenders will lower into the wash solution and spin to sanitize. SANITIZING will display on the screen.



Follow the on screen instruction. When prompted REMOVE CUP, remove the red cup(s) and pour sanitizing solution down the drain.



Close the blender door(s) and RINSING will display on the screen while the machine rinses the blenders.

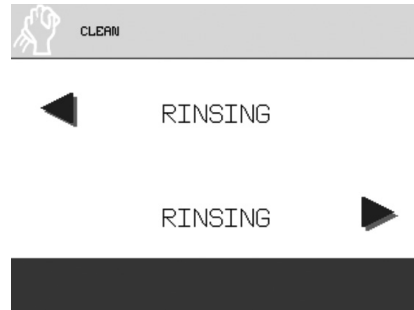

FINISHED will display on the screen, then progress to the Blender Station Sanitizing screen.

**Blender Station Sanitizing**

1. Completely spray blender station with sanitizer solution. Use cleaning brush to thoroughly scrub down the entire area.\*

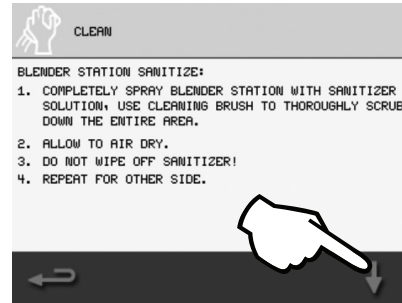

2. Allow to air dry.
3. **Do not wipe off sanitizer!**
4. Repeat for other side if applicable.
  - Press the down arrow to continue.

## Dispensing Area Sanitizing

1. Thoroughly spray each individual dispense nozzle with sanitizer solution.

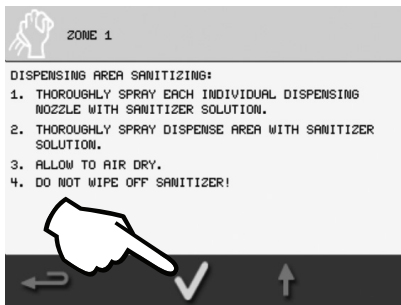

2. Thoroughly spray dispense area with sanitizer solution.
3. Allow to air dry.
4. **Do not wipe off sanitizer!**
5. Remove gloves and safety glasses.\*
  - Press the green check to signify you have completed the Zone 1 Daily Cleaning.

### Weekly Cleaning - Zone 2

NOTE: The following procedures are the basic weekly cleaning instructions, on-screen instructions can vary depending on the recipe that was created with the MenuConnect program or options chosen in the Managers Menu. *\*These items are optional and may not be displayed on all easyToUCH screens during ZONE 2 Cleaning.*

- Time to complete - 1 hour

1. Cycle touch screen to the Main Menu and select the Cleaning icon.



2. In the Cleaning screen select the ZONE 2 icon.

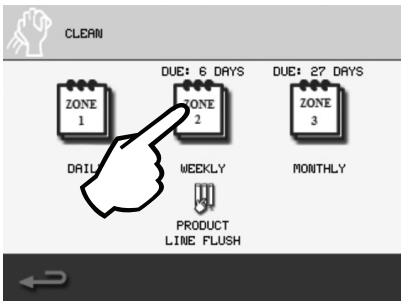

NOTE: Failure to complete the weekly cleaning sequence entirely will not reset the weekly cleaning timer and will require the process to be repeated.

### GATHER THE FOLLOWING SUPPLIES

Follow the on-screen instructions and gather the following supplies:

<b>Clean towels (Cloths*)</b>	
<b>Spray Cleaner &amp; Detergent Solution</b> (Approved dish detergent solution)	
<b>Spray Sanitizer &amp; Solution</b> (Approved sanitizer solution that provides 100 ppm available chlorine.)	
<b>Red &amp; Blue Cleaning Cups</b> (1 of each per blender station)	
<b>Set of Three (3) Cleaning Buckets</b> (Wash, Rinse & Sanitize Solutions)	
<b>Splash Shield</b>	
<b>Cleaning Manifold</b>	
<b>Drain cleaner &amp; Dispenser*</b>	
<b>Cleaning Brush, Gloves &amp; Safety Glasses*</b>	
<i>* These items are optional and may not be displayed on all easyToUCH screens.</i>	

NOTE: If other cleaners are used, it is possible they will not clean or sanitize your machine to NSF standards.

- Press the down arrow to continue.

**PRODUCT LINE CLEANING & SANITIZING**

**Prepare Cleaning Solutions**

Follow the on screen instructions:

1. Put on gloves & safety glasses.\*
2. Fill wash bucket with water and add detergent. (Approved dish detergent solution.)
3. Fill rinse bucket with water.
4. Fill sanitizer bucket with water and add approved sanitizer. (Approved sanitizer solution that provides 100 ppm available chlorine.)
5. Fill blue cleaning cup(s) with wash solution and set aside. (Approved dish detergent solution.)

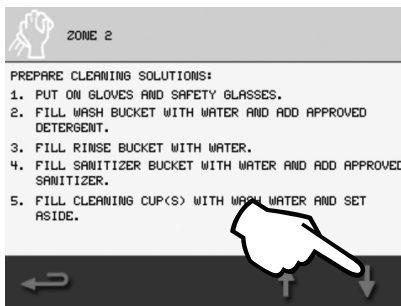

- Press the down arrow to continue.

6. Fill red sanitizing cup(s) with sanitizing solution and set aside. (Approved sanitizer solution that provides 100 ppm available chlorine.)
  - Press the down arrow to continue.

**Washing Instructions**

1. Remove grate from center dispensing area.
2. Install splash guard in dispense area.
3. Remove product holders from cabinet.
4. Take product holders to refrigerated storage.

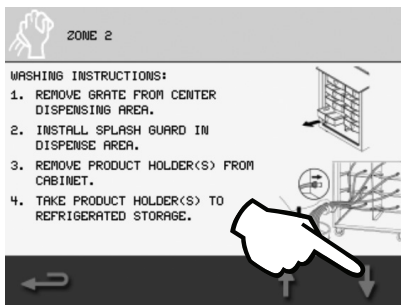

- Press the down arrow to continue.

5. Spray and wipe each BIB connector and area with cleaner.
6. Spray each BIB connector and area with sanitizer.
7. Connect a cleaning hose to each product nozzle.
  - Press the down arrow to continue.
8. Place cleaning manifold in wash bucket.
9. Press the green check to begin cleaning the lines.

This will automatically send the wash solution through each line (slot), displaying the progress on the screen, 30 seconds per slot.

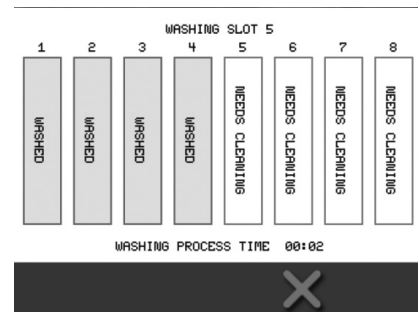

When washing has completed, the Rinsing Instructions screen will appear automatically.

**Rinsing Instructions**

1. Remove cleaning manifold from wash bucket.
2. Place cleaning manifold in rinse bucket.

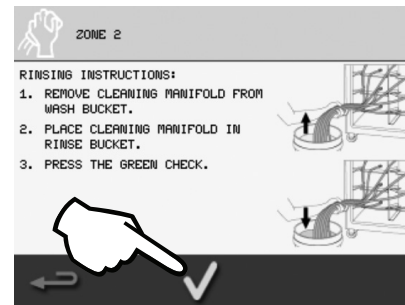

3. Press the green check to begin rinsing the lines.

This will automatically send the rinse solution through each line (slot), displaying the progress on the screen, 30 seconds per slot.

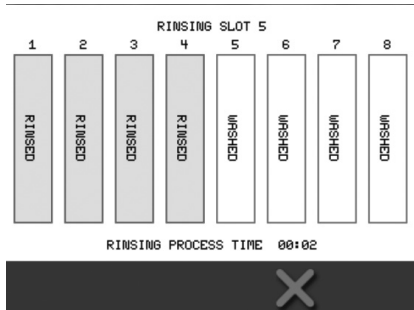

When rinsing has completed, the Sanitization Instructions screen will appear automatically.

**Sanitization Instructions**

1. Remove cleaning manifold from rinse bucket.
2. Place cleaning manifold in sanitize bucket.

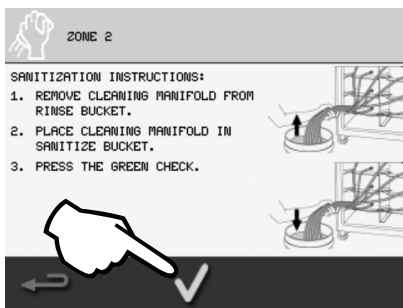

3. Press the green check to begin sanitizing the lines.

This will automatically send the sanitizing solution through each line (slot), displaying the progress on the screen, 30 seconds per slot.

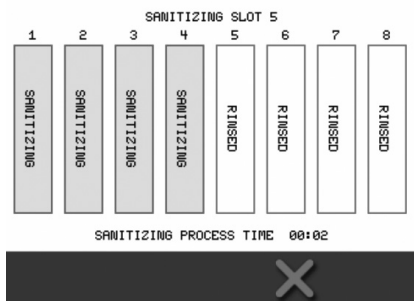

When sanitizing has completed, the Purging Instructions screen will appear automatically.

**Purging Instructions**

1. Disconnect the cleaning hoses from the product nozzles.

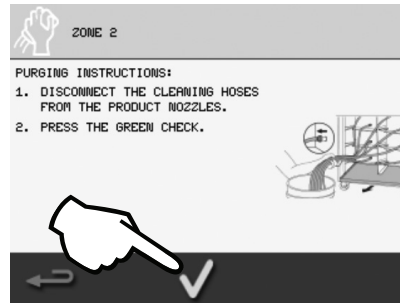

2. Press the green check to begin purging the lines. Air is pushed through each line (slot) blowing out any remaining liquid, displaying the progress on the screen, 30 seconds per slot.

When purging has completed, the Reinstall Inventory screen will appear automatically.

**Reinstall Inventory**

1. Retrieve product holders from refrigerated storage.
2. Reinstall each product holder into correct slot.
3. Remove splash guard from dispense area.
4. Reinstall center grate under dispensing area.

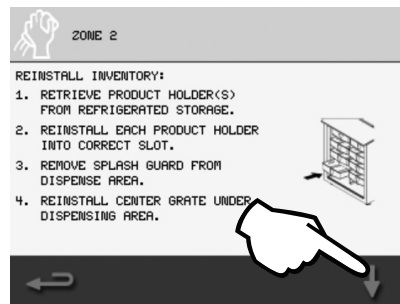

- Press the down arrow to continue.

- Place a large cup under dispensing nozzles.
- Press the green check to prime each line.

This will automatically prime each line with product. The screen will read PRIMING SLOT X. Each slot will change from PURGED to PRIMED.

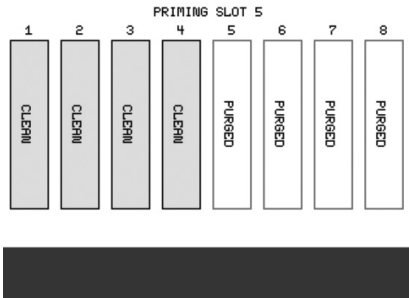

When priming has completed the Prime Complete screen will appear automatically.

**Auto Prime Complete**

- Remove and dispose of large cup with primed product.

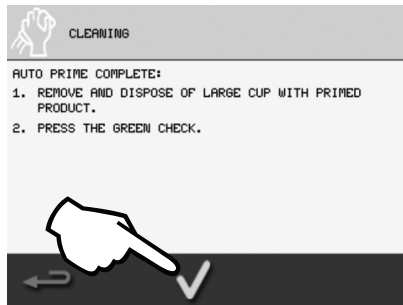

- Press the green check to continue to the Sanitizing Ice Bin & Water Nozzles screen. If this feature is not turned on in the Managers Menu, proceed to “Blenders / Dispense Area Cleaning & Sanitizing” on page 45.

**SANITIZING ICE BIN & WATER NOZZLES (OPTIONAL)**

*\*These steps will only display during the ZONE 2 Cleaning on units with this feature turned on in the Managers Menu. If this feature is not active, the interface will automatically proceed to “Blenders / Dispense Area Cleaning & Sanitizing” on page 45.*

**Gather the Following Supplies**

<b>Cleaning Buckets - Set of Three (3)</b>	
<b>Cleaning Hose*</b> (Located below product bins)	
<b>Ice Removal Chute</b>	
<b>Splash Guard</b>	
<b>Sanitizing Solution</b> (Approved sanitizer solution that provides 100 ppm available chlorine.)	
<b>Cleaning Manifold</b>	
<b>Cleaning Brush, Gloves &amp; Safety Glasses*</b>	
<small>* These items are optional and may not be displayed on all easyToUCH screens.</small>	

NOTE: If other cleaners are used, it is possible they will not clean or sanitize your machine to NSF standards.

- Press the down arrow to continue.

**Removal of Ice**

Follow the on screen instructions:

1. Install ice removal chute in dispenser area.
2. Place empty bucket on floor under ice chute.

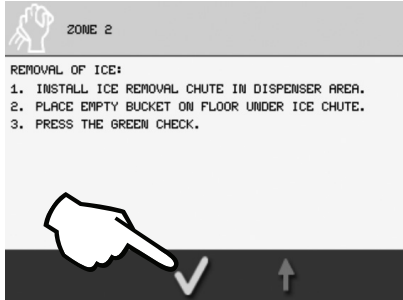

3. Press the green check to begin dispensing ice.
  - The Ice Dispensing Timer screen will display, and the machine will empty of ice.



**Ice Disposal**

1. Dispose of ice in the bucket and set aside.
2. Remove ice removal chute from the dispenser area and set aside.

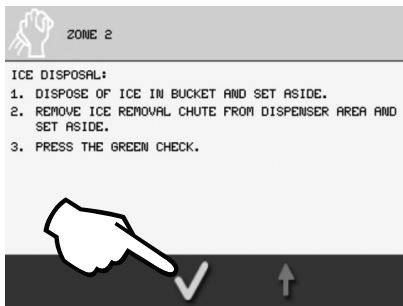

3. Press the green check.

**Sanitizing Ice Bin & Water Nozzles Prep**

1. Install splash guard in dispense area.
2. Put on gloves and safety glasses.\*
3. Fill sanitizer bucket with water and add sanitizer. (Use approved sanitizer solution that provides 100 ppm available chlorine.)
4. Place cleaning hose into the sanitizer bucket.

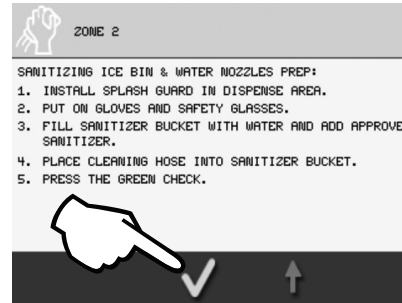

5. Press the green check to begin sanitizing the ice bin and water nozzles.
  - The Sanitizing Timer screen will display, and count down during the sanitizing process.

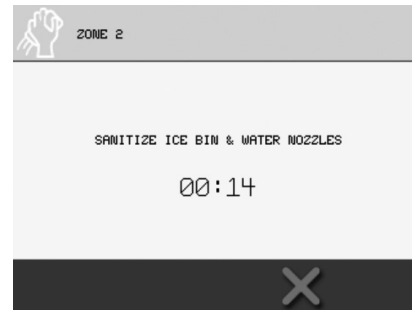

**Discard Sanitizer**

1. Install cleaning hose into the bottom of refrigerated cabinet.
2. Discard remaining sanitizer from the bucket.

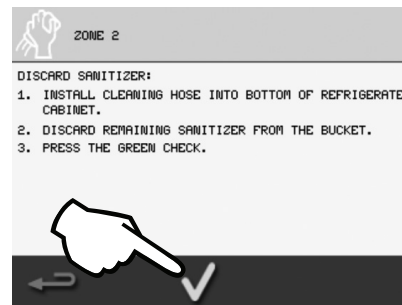

3. Press green check to continue.

**Rinsing Sanitizer Prep**

1. Install splash guard in the dispense area.

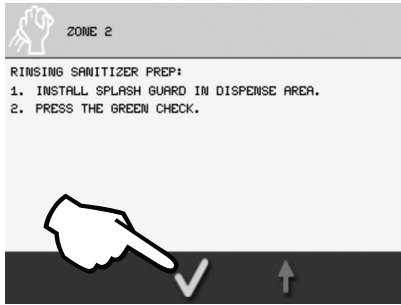

2. Press the green check to begin the plain water rinse cycle.



- The Rinse Timer screen will display and count down during the rinsing process, then automatically proceed to the Grate Removal/Blender Station Wash screen.

**BLENDERS / DISPENSE AREA CLEANING & SANITIZING**

**Grate Removal / Blender Station Wash**

1. Put on gloves and safety glasses.\*
2. Remove grate from the mixer station(s).
3. Spray all surfaces inside blender station with cleaning solution. Then scrub thoroughly with approved cleaning brush.\*

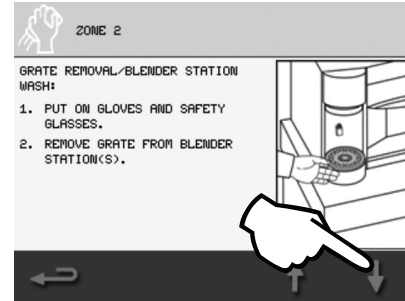

- Press the down arrow to continue.
4. Thoroughly wipe down all surfaces of mixer station and repeat for the other side if applicable.
- Press the down arrow to continue.

**Dispensing Area Cleaning**

1. Remove center grate from dispensing area.
2. Spray all dispensing area surfaces with cleaning solution. Then use approved cleaning brush to thoroughly scrub area.\*

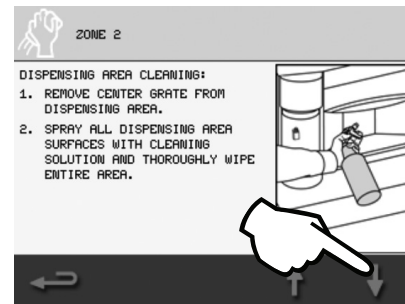

- Press the down arrow to continue.
3. Thoroughly spray each individual dispense nozzle with cleaning solution and apply cleaner to each individual dispensing valve. Then use approved cleaning brush to carefully scrub area.\*
  4. Thoroughly wipe all dispense valves and dispense area with a clean towel.
- Press the down arrow to continue.

**Mixer Door Removal**

1. Slightly open mixer door.
2. Squeeze at bottom of door.
3. Tilt out and pull the door down and out.
4. Repeat for other door if applicable.

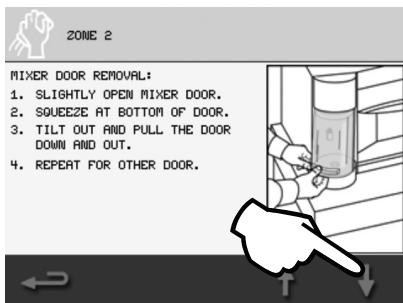

- Press the down arrow to continue.

**Blender Station Wash**

1. Completely spray blender station with cleaning solution. Use cleaning brush to thoroughly scrub down the entire area.\*
2. Using the approved cleaning brush, thoroughly scrub down top of blender cap and blender arm.\*
3. Lift blender cap and thoroughly scrub (with the approved cleaning brush) top of blade housing and bottom of blender cap.\*

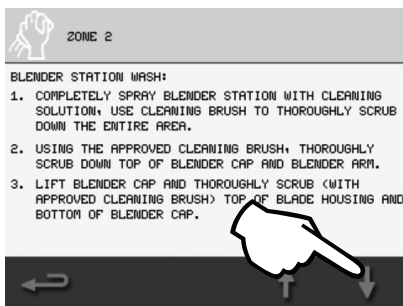

- Press the down arrow to continue.
4. Thoroughly spray with sanitizer solution.
  5. Using the approved cleaning brush, scrub entire blender assembly.\*
  6. Repeat for other side if applicable.
- Press the down arrow to continue.

**Reinstall Grate(s)/Door(s)**

1. Take all grate(s) and door(s) to sink to wash and sanitize.

**Important**

Never Use Steel Pads, Wire Brushes, Scrapers, or any Abrasive Cleaners / Scouring Pads!

2. Do not put in dishwasher or power soaker.
3. Reinstall mixer grate(s).
4. Reinstall dispensing area grate.
5. Reinstall mixer door(s).



- Press the down arrow to continue.

**Blender Wash**

1. Place blue cleaning cup(s) with wash solution in blender station(s) and close the blender doors.
- Use approved dish detergent solution.

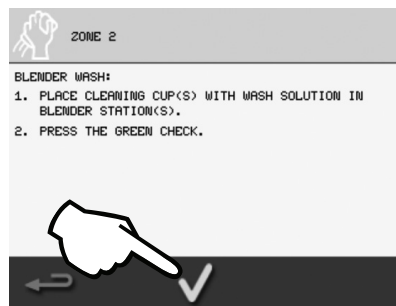

2. Press the green check to begin.

The blenders will lower into the wash solution and spin to clean. WASHING will display on the screen.



Follow the on screen instruction. When prompted REMOVE CUP, remove the blue cup(s) and pour wash solution down the drain.



Close the blender door(s) and RINSING will display on the screen while the machine rinses the blenders.

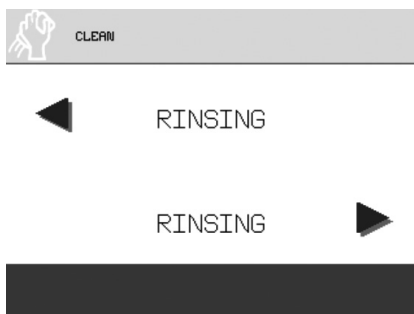

FINISHED will display on the screen, then progress to the Blender Sanitizing screen.

**Blender Sanitizing**

1. Place red sanitizing cup(s) with sanitizing solution in blender station(s) and close the blender doors.
  - Use approved sanitizer solution that provides 100 ppm available chlorine.

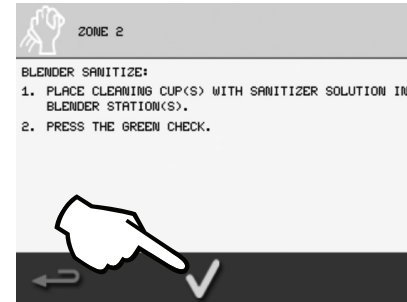

2. Press the green check to begin. The blenders will lower into the wash solution and spin to sanitize. SANITIZING will display on the screen.

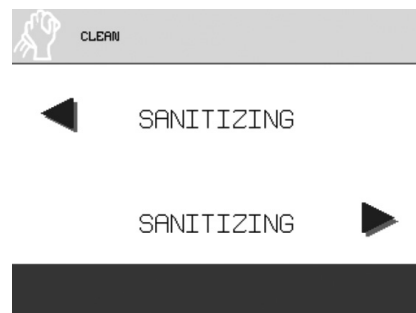

Follow the on screen instruction. When prompted REMOVE CUP, remove the red cup(s) and pour sanitizing solution down the drain.



Close the blender door(s) and RINSING will display on the screen while the machine rinses the blenders.

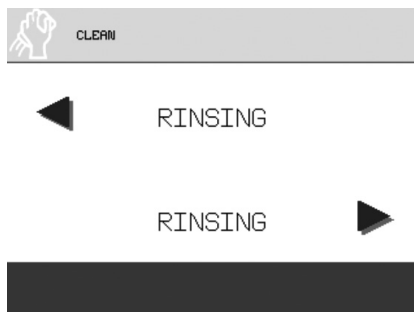

FINISHED will display on the screen, then progress to the Blender Station Sanitizing screen.

### Blender Station Sanitizing

1. Completely spray blender station with sanitizer solution. Use cleaning brush to thoroughly scrub down the entire area.\*
2. Allow to air dry.
3. **Do not wipe off sanitizer!**
4. Repeat for other side if applicable.

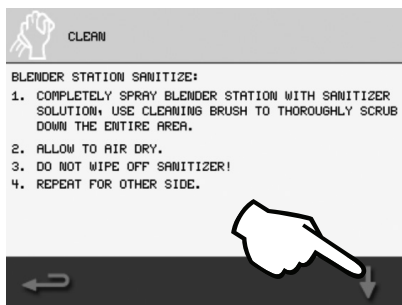

- Press the down arrow to continue.

### Dispensing Area Sanitizing

1. Thoroughly spray each individual dispensing nozzle with sanitizer solution.

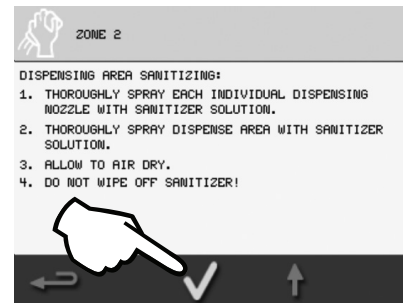

2. Thoroughly spray dispense area with sanitizer solution.
3. Allow to air dry.
4. **Do not wipe off sanitizer!**
  - Press the green check to continue on to "Drain Cleaning (Optional)" on page 49 if equipped with this option. If not equipped with this option, the Weekly Cleaning Screen will display. See "Weekly Cleaning Completed" on page 50.

## DRAIN CLEANING (OPTIONAL)

*\*Only for units with this feature. These steps will only display during the ZONE 2 Cleaning on units with this feature turned on in the loaded recipe file. If this feature is not active, the interface will automatically proceed to "Weekly Cleaning Completed" on page 50.*

### Prepare Unit for Drain Cleaning

1. Remove doors from blender station(s).
2. Remove grate from center dispensing area.
3. Remove grate from blender station(s).

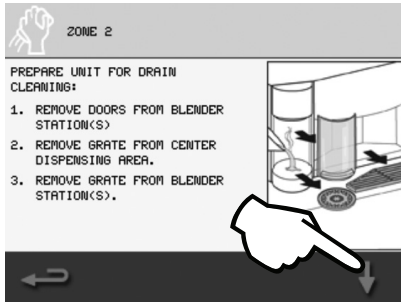

- Press the down arrow to continue.

4. Slowly pour 1 gal / 3.8 L of hot (120-130°F / 49-54°C) water into each drain.

- Press the down arrow to continue.

### Prepare Drain Cleaning Solution

1. On the top of the dispenser, open pressure relief knob by turning counter-clockwise.
2. Remove the cap from the dispenser.
  - Press the down arrow to continue.
3. Pour 1 gal / 3.8 L of hot (120-130°F / 49-54°C) water into the dispenser. **DO NOT EXCEED 140°F/60°C.**
  - Press the down arrow to continue.
4. Quickly pour one packet of drain cleaner into dispenser.
5. Immediately replace and tighten cap.

6. On the top of the dispenser, close pressure relief knob by turning clockwise.

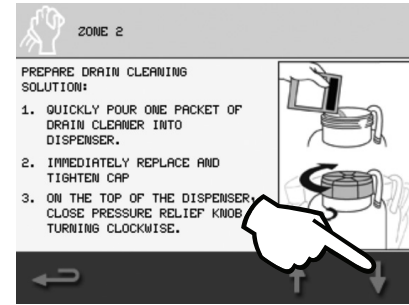

- Press the down arrow to continue.

7. Shake dispenser to dissolve cleaner.

- Press the down arrow to continue.

### Drain Cleaning

1. Carefully purge a small amount of solution from the dispenser into the sink.
2. This helps prevent "sputtering" of solution and possible splash onto clothing or eyes.

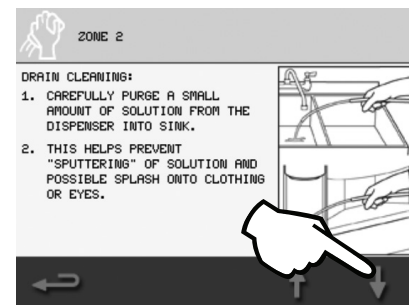

- Press the down arrow to continue.

3. Carefully spray an equal amount of the solution into each drain.

- Press the down arrow to continue.

### Post Drain Cleaning

1. Open the pressure relief knob again by turning counter-clockwise.
2. Remove cap from the dispenser.
3. Rinse the dispenser with warm (75-90°F/23-32°C) water and return to the proper storage area.

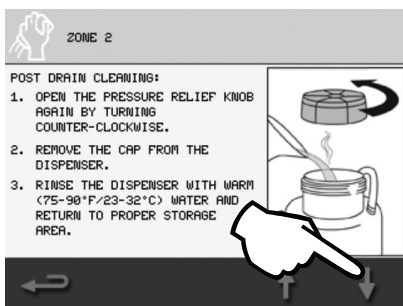

- Press the down arrow to continue.

### Reinstall Grate(s) / Door(s)

1. Wipe drain areas and work surface with sanitized towel to remove drain cleaner.
2. Reinstall mixer grate(s).
3. Reinstall dispensing area grate.
4. Reinstall mixer door(s).

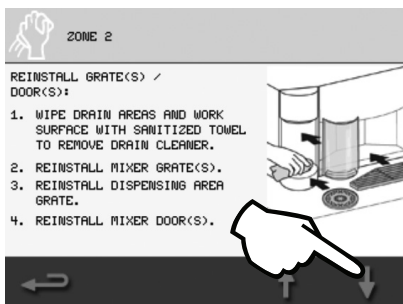

- Press the down arrow to continue.

#### Important

Drain cleaner is most effective when left for four (4) hours, but the machine can be used as needed.

- Press the green check to continue.

### Weekly Cleaning Completed

1. Remove gloves and safety glasses.\*
2. Weekly cleaning has been completed.
3. Unit will need to be cleaned again in 7 days.
4. Return supplies to cleaning kit.

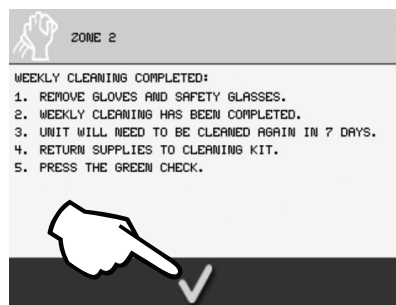

5. Press the green check to signify you have completed the Zone 2 Weekly Cleaning. The screen will return to the Main Menu screen.

### Monthly Cleaning - Zone 3

NOTE: All steps will be displayed on screen. *\*These items are optional and may not be displayed on all easyToUCH screens during ZONE 3 Cleaning.*

- Time to complete - 1 hour 45 minutes

1. Cycle touch screen to the Main Menu and select the Cleaning icon.



2. In the Cleaning screen select the ZONE 3 icon.

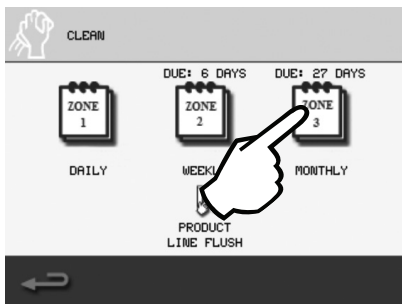

NOTE: Failure to complete the Zone 3 cleaning sequence in its entirety could affect drink quality and will not reset the monthly cleaning timer which will require the process to be repeated.

### GATHER THE FOLLOWING SUPPLIES

Follow the on-screen instructions and gather the following supplies:

<b>Cleaning Buckets - Set of Two (2)</b>	
<b>Cleaning Hose*</b> (Located below product bins)	
<b>Ice Removal Chute</b>	
<b>Splash Guard</b>	
<b>Clean towels (Cloths*)</b>	
<b>Sanitizing Solution</b> (Approved sanitizer solution that provides 100 ppm available chlorine.)	
<b>Cleaning Brush, Gloves &amp; Safety Glasses*</b>	
<i>* These items are optional and may not be displayed on all easyToUCH screens.</i>	

If other cleaners are used, it is possible they will not clean or sanitize your machine to NSF standards.

- Press the down arrow to continue.

## ICE MAKER CLEANING & SANITIZING

### Removal of Ice

Follow the on screen instructions:

1. Install ice removal chute in dispenser area.
2. Place empty bucket on floor under ice chute.

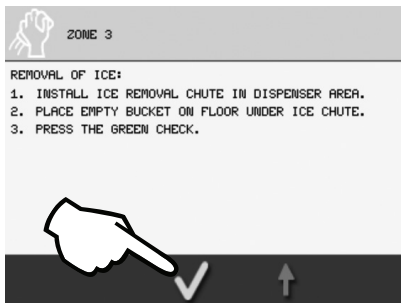

3. Press the green check to begin dispensing ice.
  - The Ice Dispensing Timer screen will display, and the machine will empty of ice.

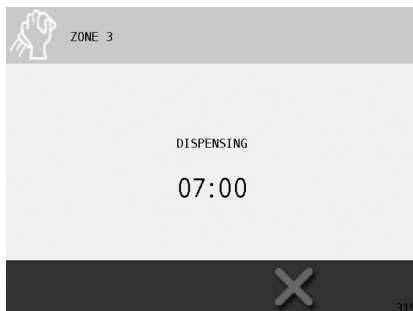

### Ice Disposal

1. Dispose of ice in the bucket and set aside.
2. Remove ice removal chute from the dispenser area and set aside.

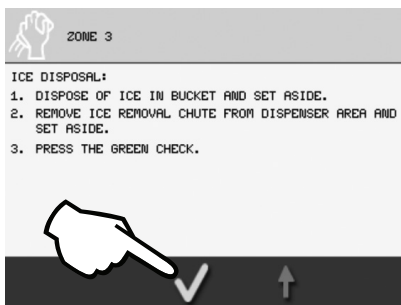

3. Press the green check to continue.

### Sanitizing Ice Maker Prep

1. Install splash guard in the dispense area.
2. Put on gloves and safety glasses.\*
3. Fill sanitizer bucket with water and add sanitizer. (Use approved sanitizer solution that provides 100 ppm available chlorine.)
4. Place cleaning hose into the sanitizer bucket.

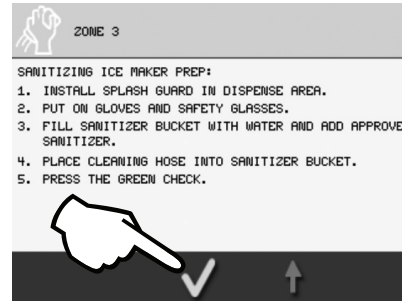

5. Press the green check to begin sanitizing the ice machine.
  - The Sanitize Ice Maker Timer screen will display and count down during the sanitizing process.

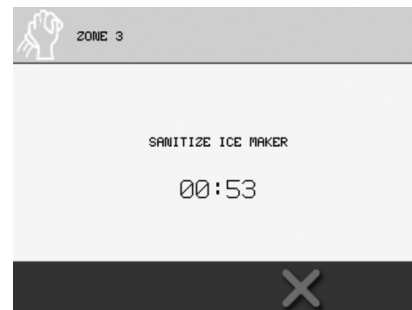

- Discard Sanitizer & Ice Purge Prep screen will display once completed.

**Discard Sanitizer & Ice Purge Prep**

1. Discard remaining sanitizer from the bucket.
2. Removal of Ice.
3. Install ice removal chute in dispenser area.
4. Place empty bucket on the floor under the ice chute.

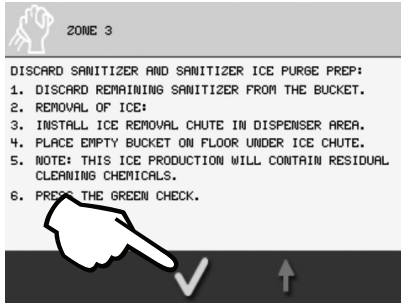

**⚠ Warning**

This ice production will contain residual cleaning chemicals and must be discarded.

5. Press the green check to begin dispensing ice.
  - The Ice Dispensing Timer screen will display, and the machine will empty of ice.



**Ice Disposal**

1. Dispose of ice in the bucket and set aside.
2. Remove ice removal chute from the dispenser area and set aside.

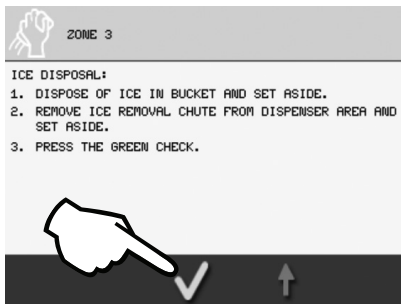

3. Press the green check to continue.

**Sanitizing Ice Bin & Water Nozzles Prep**

1. Install splash guard in dispense area.
2. Put on gloves and safety glasses.\*
3. Fill sanitizer bucket with water and add sanitizer. (Use approved sanitizer solution that provides 100 ppm available chlorine.)
4. Place cleaning hose into the sanitizer bucket.

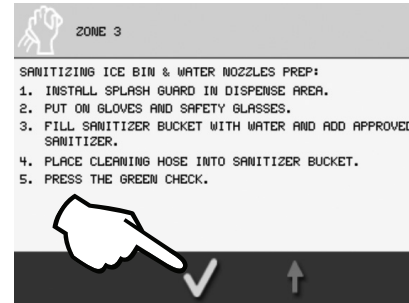

5. Press the green check to begin sanitizing the ice bin and water nozzles.
  - The Sanitizing Timer screen will display, and count down during the sanitizing process.

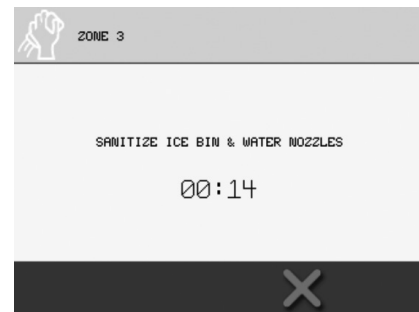

**Discard Sanitizer**

1. Install cleaning hose into the bottom of refrigerated cabinet.
2. Discard remaining sanitizer from the bucket.

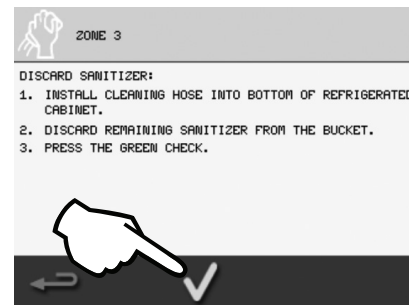

3. Press green check to continue.

**Rinsing Sanitizer Prep**

1. Install splash guard in the dispense area.

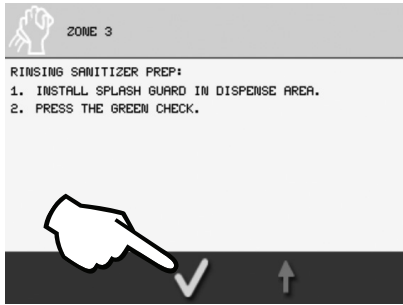

2. Press the green check to begin the plain water rinse cycle.
  - The Rinse Timer screen will display, and count down during the rinsing process then automatically proceed to the Cleaning Solution Ice Production screen.



**Ice Maker Cleaning Solution Ice**

- Ice will then be produced using water from the unit's chilled water source to remove any remaining cleaning solution from the ice maker.

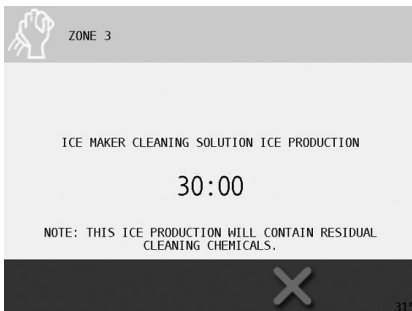

**Warning**

This ice production will contain residual cleaning chemicals and must be discarded.

**Removal of Ice**

1. Install ice removal chute in dispenser area.
2. Place empty bucket on floor under ice chute.

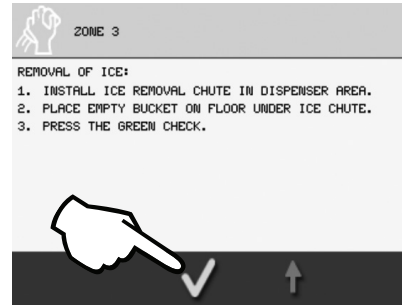

3. Press the green check to begin dispensing ice.
  - The Ice Dispensing Timer screen will display, and the machine will empty of ice.

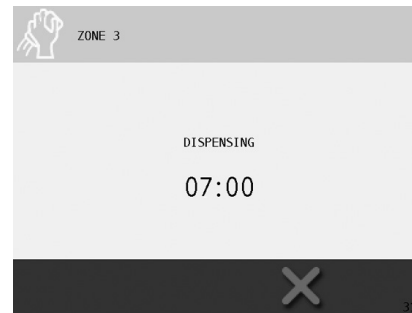

**Ice Disposal**

1. Dispose of ice in the bucket and set aside.
2. Remove ice removal chute from the dispenser area and set aside.

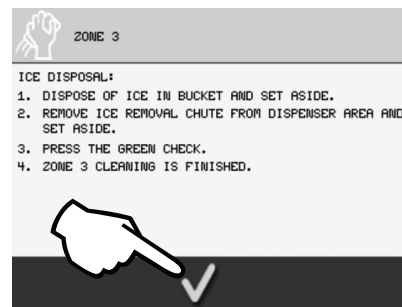

3. Press the green check to signify you have completed the Zone 3 Monthly Cleaning. The screen will return to the Main Menu screen.

**Important**

Ice storage has been depleted, low ice level may exist for 30 minutes!

## OTHER MONTHLY TASKS

### Air Filters

For units equipped with upper and/or lower air filters. Each month check the air filters to be sure they are clean and allow proper airflow.

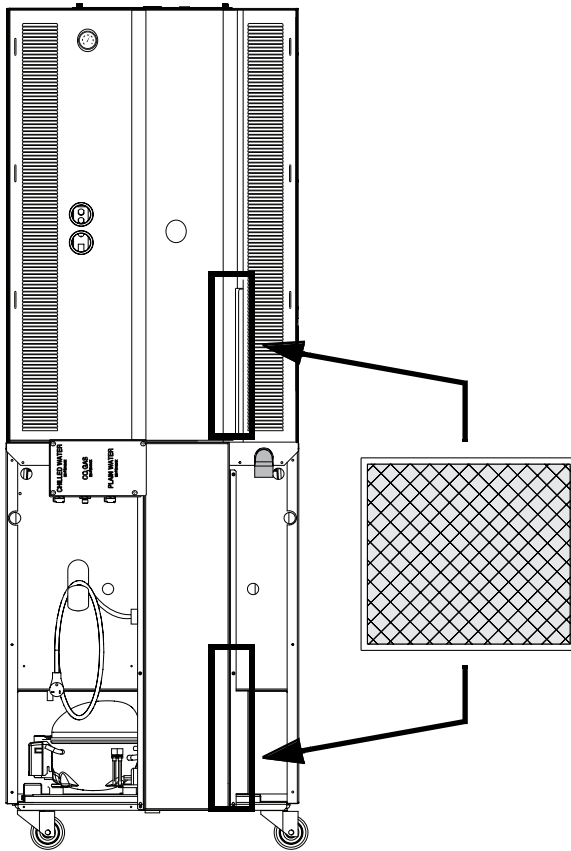

**Air Filter Locations**

First access the rear of the unit. Slide them out one at a time and inspect them. If they are dirty or light will not pass through them when held up to light, take to a sink and wash with dish soap until clean. DO NOT put in a dishwasher.

Once clean, slide them back into place on the unit and move unit back into place.

### Cleaning the Condenser Coil

In order to maintain proper refrigeration performance, the condenser fins must be cleaned of dust, dirt and grease regularly. It is recommended that this be done at least every three months. If conditions are such that the condenser is totally blocked in three months, the frequency of cleaning should be increased. Clean the condenser with a vacuum cleaner or stiff brush. If extremely dirty, a commercially available condenser cleaner may be required.

Failure to maintain a clean condenser coil can initially cause high temperatures and excessive run times. Continuous operation with a dirty or clogged condenser coil can result in compressor failure. Neglecting the condenser coil cleaning procedures will void any warranties associated with the compressor and cost to replace the compressor.

### Caution

Never use a high-pressure water wash for this cleaning procedure as water can damage the electrical components located near or at the condenser coil.

### Exterior Cleaning

Remove dust and dirt from the exterior surfaces with a mild household dishwashing detergent and warm water. Wipe dry with a clean, soft cloth.

Use cleaners designed for use with stainless steel products.

Heavy stains should be removed with stainless steel wool. Never use plain steel wool or abrasive pads. They will scratch the panels.

### Biannual Descaling - Zone 3

Descaling is recommended every six (6) months. More frequent descaling may be required in some existing water conditions. Follow carefully any instructions provided with the bottles of Ice Machine Descaling or sanitizing solution.

#### Warning

Always wear liquid-proof gloves to prevent the descaling and sanitizing solutions from coming into contact with skin.

NOTE: All steps will be displayed on screen. \*These items are optional and may not be displayed on all easyToUCH screens during ZONE 3 Cleaning.

- Time to complete - 2 hours

Descaling must first be turned on in the Manager Menu Service Screen before it can be performed as part of Zone 3 cleaning and will need to be turned off once completed.

#### Important

Only a trained manager or authorized technician should access the service screens. If changes to these settings are made incorrectly they can cause the unit to malfunction or not work at all.

#### TURN ON DESCALING

1. Cycle touch screen to the Main Menu and select the Managers Menu icon.

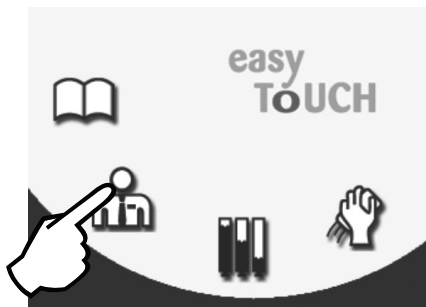

2. Enter the password using the QWERTY keyboard.

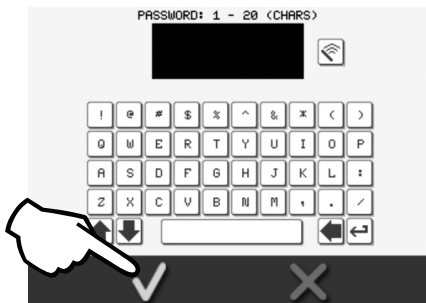

3. Press the down arrow to advance to the next screen.

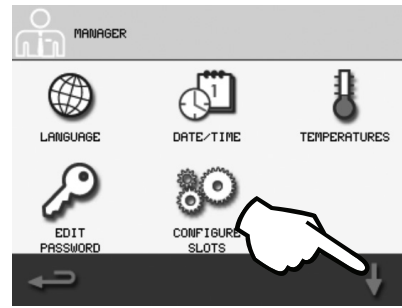

4. Select the Service icon.

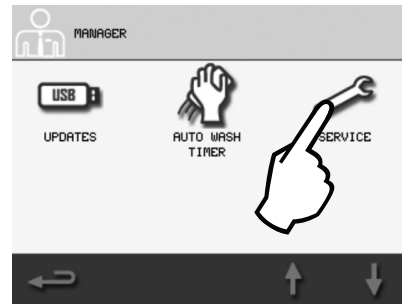

5. Enter the password using the QWERTY keyboard.

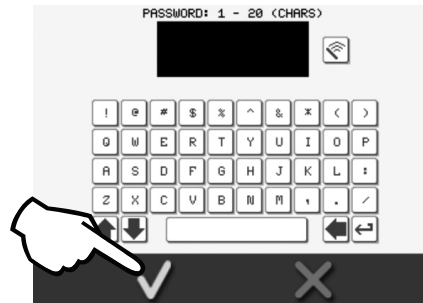

6. Select the CLEANING OPTIONS button.

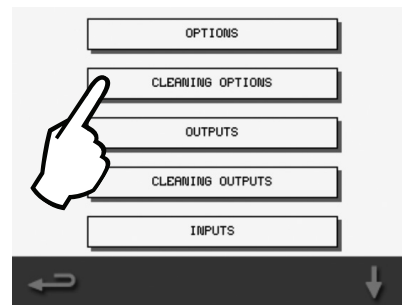

7. Turn ON Descaling:

- A. Touch the ZONE 3 DESCALING check box. The box should turn green with a check mark in it.

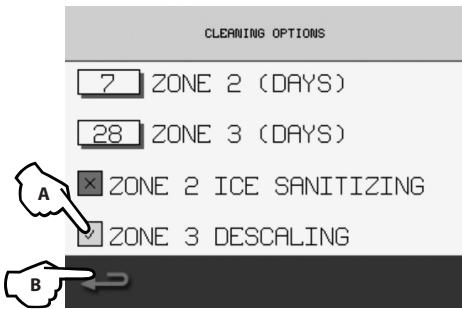

- B. Exit back out to the Main Menu using the back arrow multiple times, press SAVE when prompted.

8. Select the Cleaning icon in the Main Menu.



9. In the cleaning screen, select the ZONE 3 Icon.

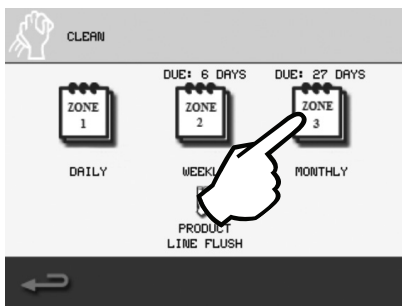

NOTE: Failure to complete the Zone 3 cleaning sequence in its entirety could affect drink quality and will not reset the monthly cleaning timer which will require the process to be repeated.

**GATHER THE FOLLOWING SUPPLIES**

Follow the on screen instructions and gather the following supplies:

<b>Cleaning Buckets - Set of Two (2)</b>	
<b>Cleaning Hose*</b> (Located below product bins)	
<b>Ice Removal Chute</b>	
<b>Splash Guard</b>	
<b>Clean Towels (Cloths*)</b>	
<b>Descaler Solution</b> (Use Approved Ice Machine Descaling Solution)	
<b>Sanitizing Solution</b> (Approved sanitizer solution that provides 100 ppm available chlorine.)	
<b>Cleaning Brush, Gloves &amp; Safety Glasses*</b>	
* These items are optional and may not be displayed on all easyToUCH screens.	

NOTE: If other cleaners are used, it is possible they will not clean or sanitize your machine to NSF standards.

- Press the down arrow to continue

**ICE MAKER / BIN DESCALING, CLEANING & SANITIZING**

**Removal of Ice**

Follow the on screen instructions:

1. Install ice removal chute in dispenser area.
2. Place empty bucket on floor under ice chute.

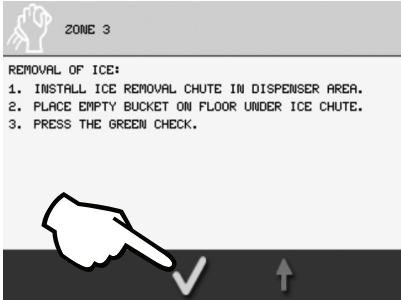

3. Press the green check to begin dispensing ice.
  - The Ice Dispensing Timer Screen will display, and the machine will empty of ice.

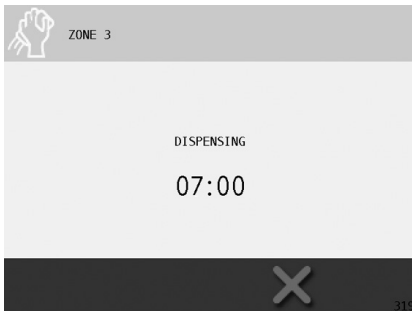

**Ice Disposal**

1. Dispose of ice in the bucket and set aside.
2. Remove ice removal chute from the dispenser area and set aside.

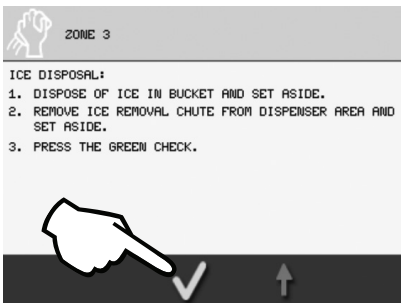

3. Press the green check to continue.

**Descaling Ice & Water System Prep**

**Important**

These steps will only display if descaling has been turned on in the Managers Menu. If this feature is not active, the interface will automatically proceed to "Sanitizing Ice Maker Prep" on page 59.

1. Install splash guard in the dispense area.
2. Put on gloves and safety glasses.\*
3. Fill sanitizer bucket with water and add descaler.

NOTE: Use approved ice machine cleaner. Consult manufacturer's instructions for correct ratio.

4. Route cleaning hose to the outside of unit.
5. Place cleaning hose into bucket with descaler solution.

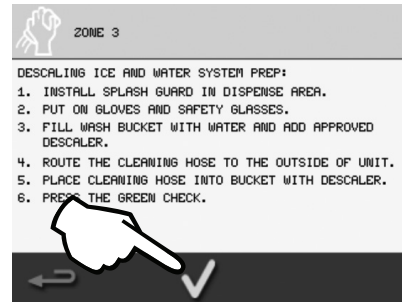

6. Press the green check to begin descaling the ice machine.
  - The Descaling Ice Maker Timer Screen will display and count down during the descaling process.

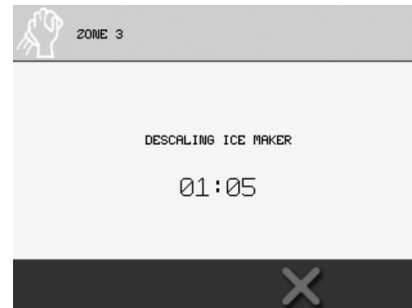

- Continue Descaling Screen will display once completed.

**Continue Descaling**

1. Discard remaining descaler from the bucket.
2. Refill bucket with water and add approved descaler.
3. Place cleaning hose back into the descaler bucket.

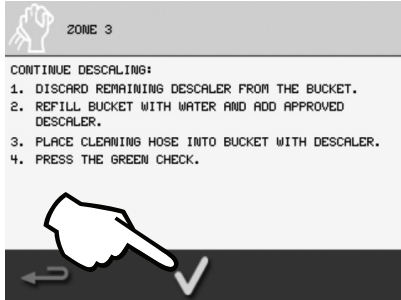

4. Press the green check to descale the ice bin and water nozzles.
  - The Descaling Bin & Nozzles Timer Screen will display and count down during the descaling process.

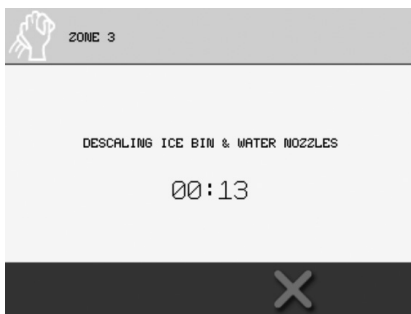

- Discard Descaler Screen will display once completed.

**Discard Descaler**

1. Discard remaining descaler from the bucket.

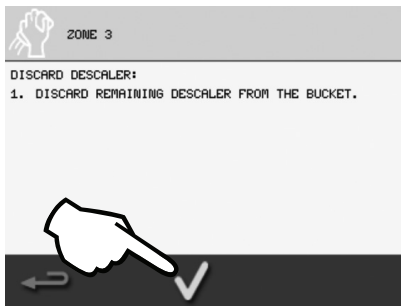

- Press the green check to continue.

**Sanitizing Ice Maker Prep**

1. Install splash guard in the dispense area.
2. Put on gloves and safety glasses.\*
3. Fill sanitizer bucket with water and add sanitizer.

NOTE: Use approved sanitizer solution that provides 100 ppm available chlorine. Consult manufacturer’s instructions for correct ratio.

4. Place cleaning hose into the sanitizer bucket.

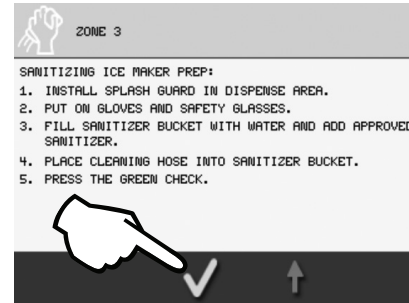

5. Press the green check to begin sanitizing the ice machine.
  - The Sanitize Ice Maker Timer Screen will display and count down during the sanitizing process.

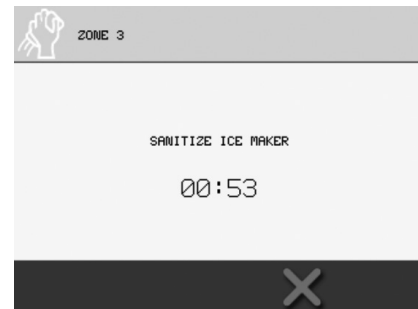

- Discard Sanitizer & Ice Purge Prep Screen will display once completed.

### Discard Sanitizer & Ice Purge Prep

1. Discard remaining sanitizer from the bucket.
2. Removal of ice.
3. Install ice removal chute in dispenser area.
4. Place empty bucket on the floor under the ice chute.

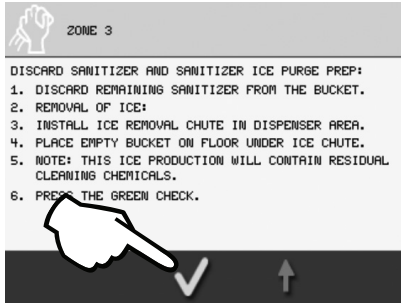

**Warning**

This ice production will contain residual cleaning chemicals and must be discarded.

5. Press the green check to begin dispensing ice.
  - The Ice Dispensing Timer Screen will display, and the machine will empty of ice.



### Ice Disposal

1. Dispose of ice in the bucket and set aside.
2. Remove ice removal chute from the dispenser area and set aside.

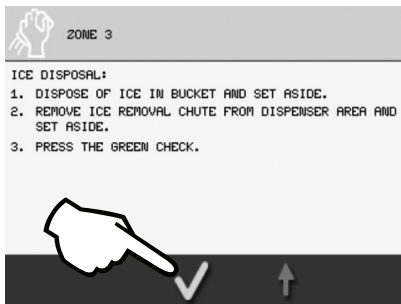

3. Press the green check to continue.

### Sanitizing Ice Bin & Water Nozzles Prep

1. Install splash guard in dispense area.
2. Put on gloves and safety glasses.\*
3. Fill sanitizer bucket with water and add sanitizer. (Use approved sanitizer solution that provides 100 ppm available chlorine.)
4. Place cleaning hose into the sanitizer bucket.

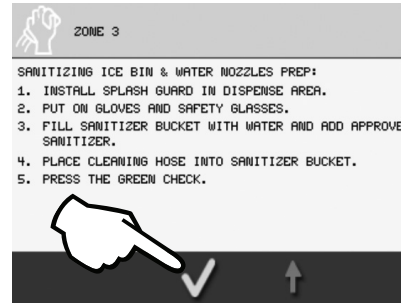

5. Press the green check to begin sanitizing the ice bin and water nozzles.
  - The Sanitizing Timer Screen will display, and count down during the sanitizing process.

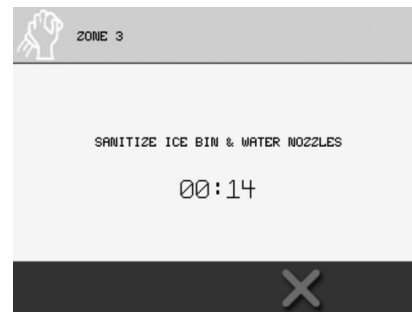

### Discard Sanitizer

1. Install cleaning hose into the bottom of the refrigerated cabinet.
2. Discard remaining sanitizer from the bucket.

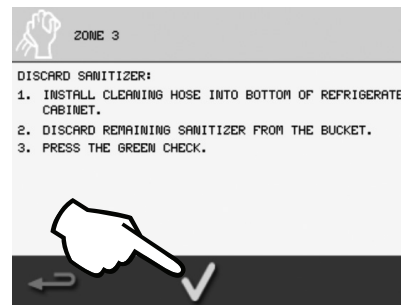

3. Press green check to continue.

### Rinsing Sanitizer Prep

1. Install splash guard in the dispense area.

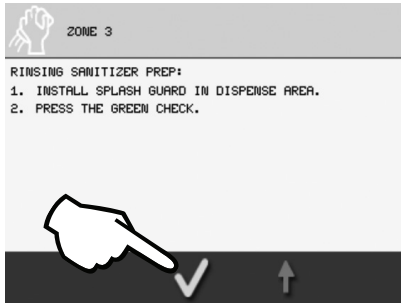

2. Press the green check to begin the plain water rinse cycle.
  - The Rinse Timer Screen will display, and count down during the rinsing process, then automatically proceed to the Cleaning Solution Ice Production Screen.



### Ice Maker Cleaning Solution Ice

- Ice will then be produced using water from the unit's chilled water source to remove any remaining cleaning solution from the ice maker.

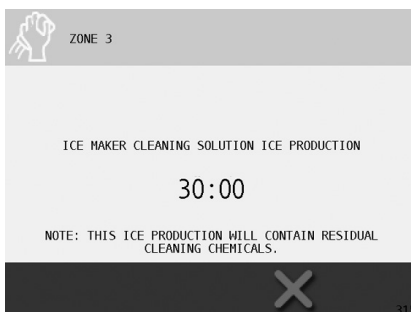

#### **Warning**

This ice production will contain residual cleaning chemicals and must be discarded.

### Removal of Ice

1. Install ice removal chute in dispenser area.
2. Place empty bucket on floor under ice chute.

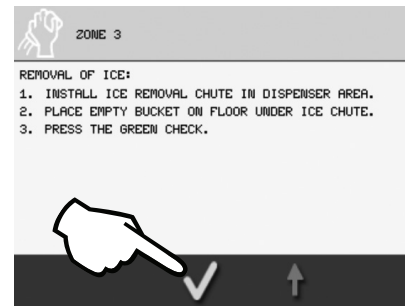

3. Press the green check to begin dispensing ice.
  - The Ice Dispensing Timer Screen will display, and the machine will empty of ice.

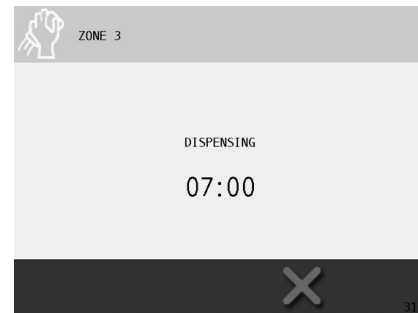

### Ice Disposal

1. Dispose of ice in the bucket and set aside.
2. Remove ice removal chute from the dispenser area and set aside.

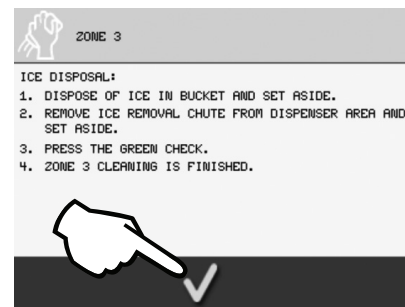

3. Press the green check to signify you have completed the Zone 3 Monthly Cleaning. The screen will return to the Main Menu screen.

**TURN OFF DESCALING**

1. From the Main Menu select the Managers Menu icon.

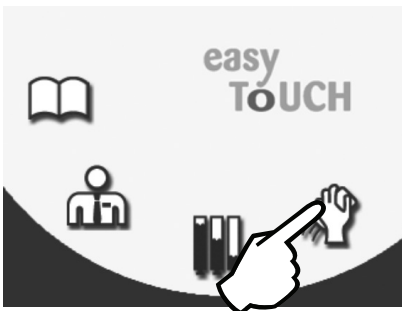

2. Enter the password using the QWERTY keyboard.

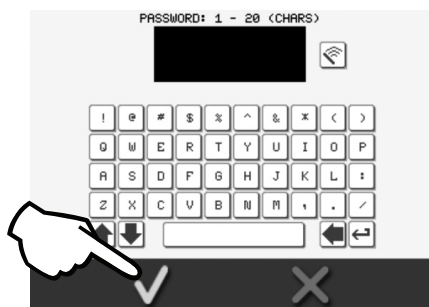

3. Press the down arrow to advance to the next screen.

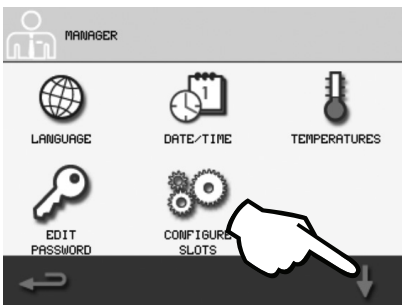

4. Select the Service icon.

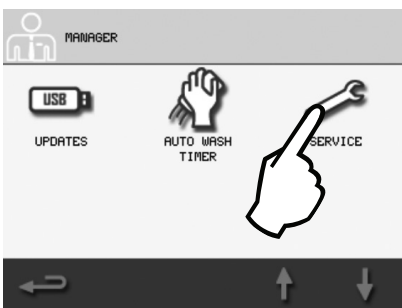

5. Enter the password using the QWERTY keyboard.

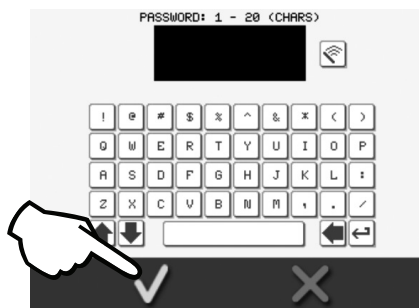

6. Select the CLEANING OPTIONS button.

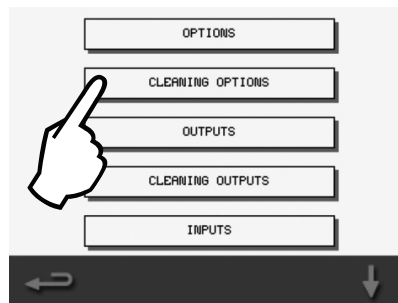

7. Turn OFF Descaling:

A. Touch the ZONE 3 DESCALING check box. The box should turn red with an "x" in it.

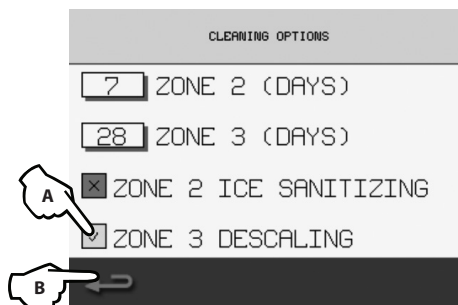

B. Exit back out to the Main Menu using the back arrow multiple times, press SAVE when prompted. Descaling is now turned off during Zone 3 Cleaning.

**Important**

Ice storage has been depleted, low ice level may exist for 30 minutes!

### Ice Machine Cleaning

These instructions are for units with internal ice maker and not equipped with the Zone 3 Clean in Place option or when manual cleaning is required.

**Important**

Only a trained manager or authorized technician should perform ice machine cleaning.

Descaling is recommended every six (6) months. More frequent descaling may be required in some existing water conditions. Sanitizing is recommended every three (3) months. Follow carefully any instructions provided with the descaling or sanitizing solutions being used.

**⚠ Warning**

Always wear liquid-proof gloves to prevent the descaling and sanitizing solutions from coming into contact with skin.

**⚠ Warning**

To prevent injury, disconnect main supply power to the dispenser (when used) before cleaning or sanitizing the bin area and dispenser parts.

#### TOOLS REQUIRED

- Gloves
- Nut driver 1/4"

#### UNIT PREPARATION

**Important**

Keep refrigeration cabinet door closed so that product remains chilled while the unit is OFF.

1. Disconnect power, remove left side and rear panels and set the power and compressor rocker switches to the OFF position.
2. Remove all ice from the bin/dispenser.
3. Turn off the ice making water supply.
4. Drain water from evaporator and reservoir through the evaporator/reservoir drain line and reinsert hose into hose clip.

### ICE MACHINE DESCALING

To be done every six (6) months. Skip to "Ice Machine Sanitizing" if just sanitizing the ice machine.

1. Use an approved descaling solution ratio noted.

Amount of Luke Warm Water	Amount of Ice Machine Cleaner
5 gallons (20 Liters)	Use approved ice machine cleaner. Consult manufacturer's instructions for ratio to make up 1 container of solution.

2. Remove top cover from the water reservoir, block up reservoir float and fill the evaporator and reservoir with cleaning solution. Remainder of solution will be used for hand cleaning.
3. Verify the compressor rocker switch is in the OFF position, then reconnect power and run the gear motor for 15 minutes. Perform the following procedures during the 15 minute period:
  - Descale drain pan by gently flexing, then remove any scale residue.
  - Inspect water feed and drain lines and clean as needed.
4. Disconnect power, then drain the cleaner/water from the evaporator and reservoir through the evaporator/reservoir drain line. Using a pitcher, fill and drain the evaporator/reservoir 4 times and reinsert the hose into the hose clip.
5. Proceed to "Ice Machine Sanitizing".

**ICE MACHINE SANITIZING**

To be done every three (3) months.

1. Use an approved sanitizing solution ratio noted.

Amount of Luke Warm Water	Amount of Sanitizer
5 gallons (20 Liters)	Use 1/4 ounce (15 ml) household bleach per gallon or approved sanitizer that provides 100 ppm available chlorine. Consult manufacturer’s instructions for ratio.

2. Fill reservoir and evaporator with sanitizer/water solution.
3. Verify the compressor rocker switch is in the OFF position, then reconnect power and run the gear motor for 10 minutes.
4. Move the compressor rocker switch to the ON position. The ice machine will make ice with the sanitizer/water solution and deposit the ice in the bin/dispenser. Make ice for 20 minutes - add sanitizer/water solution as the water level in the reservoir drops.

NOTE: Do not allow the sanitizer/water level to drop below the sensing probes. The ice machine will start a 20 minute delay period if the sensing probes lose contact with the water for more than 10 seconds. If this happens, refilling the reservoir, then disconnecting and reconnecting power will restart the ice machine.

5. Move the compressor rocker switch to the OFF position and disconnect power.
6. Drain the evaporator/reservoir and reinsert the drain hose into the hose clip.
7. Remove blocking from under reservoir float and reinstall reservoir cover.
8. Turn on the ice making water supply, reconnect power and move the compressor rocker switch to ON.
9. Allow the ice machine to run for 20 minutes, then place the compressor rocker switch in the OFF position, disconnect power and discard all ice produced.

**⚠ Warning**

This ice production will contain residual cleaning chemicals and must be discarded.

10. Replace all cleaned parts in their correct positions.

**BIN / DISPENSER DESCALE, CLEAN, & SANITIZE**

Heavy accumulations of scale may require disassembly of the bin and dispenser parts, See “Full Disassembly Descale, Clean & Sanitize”.

1. Disconnect power to the unit to prevent injury.
2. Remove the unit top by removing four thumbscrews.

**DESCALING**

To be done every six (6) months. Skip to “Sanitizing” if just sanitizing the bin/dispenser.

1. Use an approved descaling solution ratio noted.

NOTE: For safety and maximum effectiveness, use the solution immediately after dilution.

Amount of Luke Warm Water	Amount of Ice Machine Cleaner
5 gallons (20 Liters)	Use approved ice machine cleaner. Consult manufacturer’s instructions for ratio to make up 1 container of solution.

**SANITIZING**

To be done every three (3) months.

1. Use an approved sanitizing solution ratio noted.

Amount of Luke Warm Water	Amount of Sanitizer
5 gallons (20 Liters)	Use 1/4 ounce (15 ml) household bleach per gallon or approved sanitizer that provides 100 ppm available chlorine. Consult manufacturer’s instructions for ratio.

**FULL DISASSEMBLY DESCALE, CLEAN & SANITIZE**

NOTE: Disassembly of the bin and dispenser parts is not required unless heavy accumulations of scale have been found.

1. Disconnect power to the unit to prevent injury.
2. Remove the unit top by removing four thumbscrews.
3. Remove ice dispense motor assembly by removing four thumbscrews.
4. Remove ice bin cover.
5. Remove any remaining ice manually.
6. Use an approved descaling solution ratio noted.

Amount of Luke Warm Water	Amount of Ice Machine Cleaner
5 gallons (20 Liters)	Use approved ice machine cleaner. Consult manufacturer's instructions for ratio to make up 1 container of solution.

7. Use an approved sanitizing solution ratio noted.

Amount of Luke Warm Water	Amount of Sanitizer
5 gallons (20 Liters)	Use 1/4 ounce (15 ml) household bleach per gallon or approved sanitizer that provides 100 ppm available chlorine. Consult manufacturer's instructions for ratio.

8. Remove ice agitator. Descale, rinse and sanitize the ice agitator.
9. Remove the dispense wheel assembly.
10. Soak the following parts for 20 minutes in descaling solution, then rinse thoroughly:
  - Dispense Wheel and Housing
11. Soak the removed parts in sanitizing solution for 10 minutes and wipe them down.

NOTE: If solution is left on these parts, they will rust.

12. Wipe the inner ice bin wall with descaler solution. Rinse and wipe dry. Repeat with sanitizer solution. Rinse and wipe dry.
13. With a bottle brush, brush the ice nozzle at bottom of ice bin with descaler solution. Rinse and wipe dry. Repeat with sanitizer solution. Rinse and wipe dry.

14. Replace all cleaned parts in their correct positions:
  - Assembled Dispense Wheel/Plates
  - Auger
  - Bin Cover
  - Motor
15. Reinstall all removed panels.
16. Replace the unit top with four thumbscrews.
17. Restore power to the unit and turn ON the ice maker power switch.

### Product Line Flush

NOTE: The following procedures are the basic product line flushing instructions. On-screen instructions can vary depending on the recipe that was created with the MenuConnect program or options chosen in the Managers Menu. The Product Line Flush procedure allows a user to choose which lines to flush instead of being forced to flush every product line in the unit.

*\*These items are optional and may not be displayed on all easyToUCH screens during the Product Line Flush procedure.*

1. Cycle touch screen to the Main Menu and select the Cleaning icon.



2. In the Cleaning screen select the PRODUCT LINE FLUSH icon.

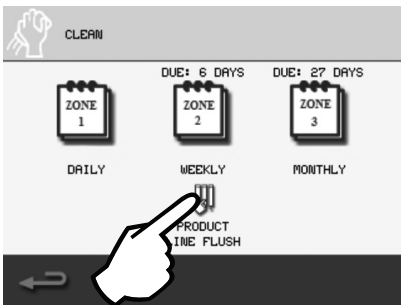

NOTE: Performing the product line flush through this interface procedure will not reset the Zone 2 cleaning countdown timer, Zone 2 cleaning will need to be performed in its entirety in order to reset the counter.

### GATHER THE FOLLOWING SUPPLIES

Follow the on screen instructions and gather the following supplies:

<b>Clean towels (Cloths*)</b>	
<b>Spray Cleaner &amp; Detergent Solution</b> (Approved dish detergent solution)	
<b>Spray Sanitizer &amp; Solution</b> (Approved sanitizer solution that provides 100 ppm available chlorine.)	
<b>Set of Three (3) Cleaning Buckets</b> (Wash, Rinse & Sanitize Solutions)	
<b>Splash Shield</b>	
<b>Cleaning Manifold</b>	
<b>Cleaning Brush, Gloves &amp; Safety Glasses*</b>	
<i>* These items are optional and may not be displayed on all easyToUCH screens.</i>	

If other cleaners are used, it is possible they will not clean or sanitize your machine to NSF standards.

- Press the down arrow to continue.

**Prepare Cleaning Solutions**

Follow the on-screen instructions:

1. Put on gloves and safety glasses.\*
2. Fill wash bucket with water and add detergent. (Approved dish detergent solution.)
3. Fill rinse bucket with water.
4. Fill sanitizer bucket with water and add approved sanitizer. (Approved sanitizer solution that provides 100 ppm available chlorine.)

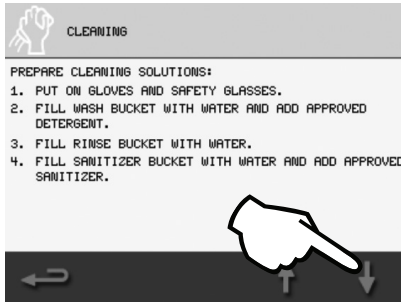

- Press the down arrow to continue.

**Washing Instructions**

1. Remove grate from center dispensing area.
2. Install splash guard in dispense area.
3. Remove product holders from cabinet.

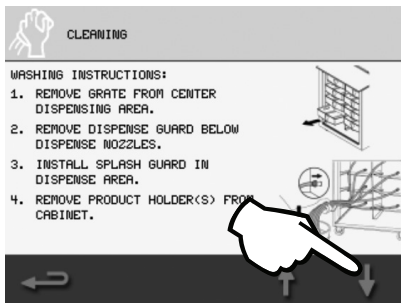

- Press the down arrow to continue.
4. Take product holders to refrigerated storage.
  5. Spray and wipe each BIB connector and area with cleaner.
  6. Spray and wipe each BIB connector and area with sanitizer.
  7. Connect a cleaning hose to each product nozzle.
    - Press the down arrow to continue.
  8. Place cleaning manifold in wash bucket.
  9. Press the green check to go to the next screen.

**Select Slots to Flush**

- A. Touch each slot that needs to be flushed, select any or all slots. Selected slots will become highlighted in green and say NEEDS CLEANING.
- Slots that are not selected will say CLEAN.
  - Slots outlined in red do not currently have a product assigned but may be selected to flush.

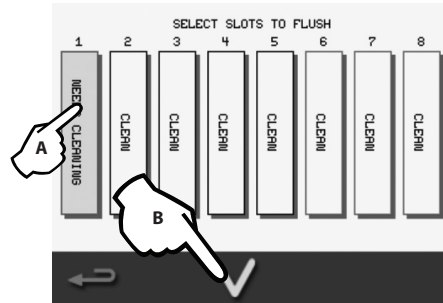

- B. The green check will appear once a slot has been selected. Once all the slots to be flushed have been selected, press the green check to continue.

This will automatically send the wash solution through each line (slot) that was selected, displaying the progress on the screen, 30 seconds per slot.

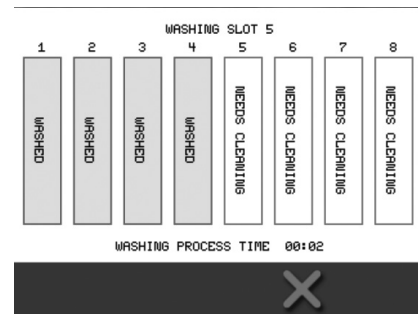

When washing has completed, the Rinsing Instructions screen will appear automatically.

**Rinsing Instructions**

1. Remove cleaning manifold from wash bucket.
2. Place cleaning manifold in rinse bucket.

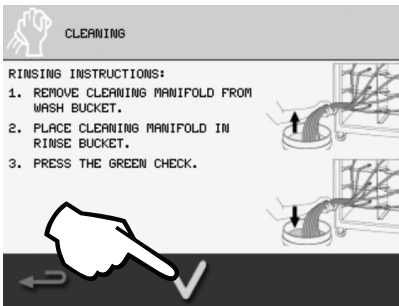

3. Press the green check to begin rinsing the lines.
- This will automatically send the rinse solution through each line (slot) that was selected, displaying the progress on the screen, 30 seconds per slot.

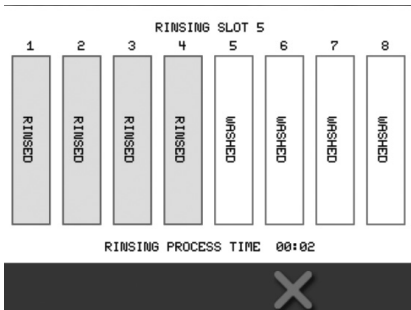

When rinsing has completed, the Sanitization Instructions screen will appear automatically.

**Sanitization Instructions**

1. Remove cleaning manifold from rinse bucket.
2. Place cleaning manifold in the sanitize bucket.

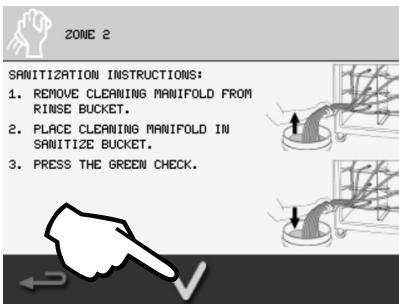

3. Press the green check to begin sanitizing the lines.

This will automatically send the sanitizing solution through each line (slot) that was selected, displaying the progress on the screen, 30 seconds per slot.

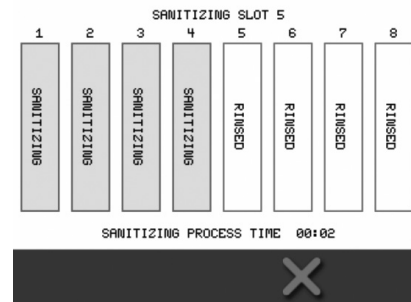

When sanitizing has completed, the Purging Instructions screen will appear automatically.

**Purging Instructions**

1. Disconnect the cleaning hoses from the product nozzles.

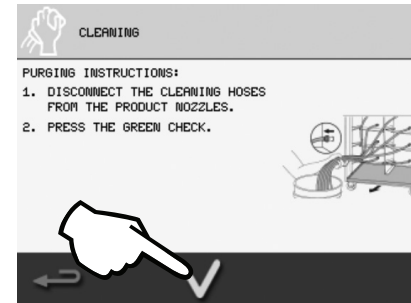

2. Press the green check to begin purging the lines.
- Air is pushed through each line (slot) that was selected, blowing out any remaining liquid, displaying the progress on the screen, 30 seconds per slot.

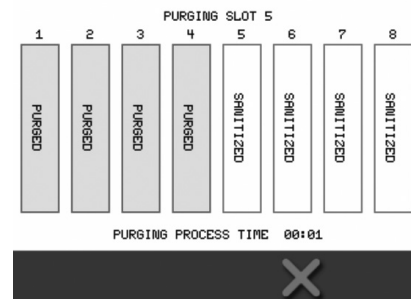

When purging has completed, the Reinstall Inventory screen will appear automatically.

**Reinstall Inventory**

1. Retrieve product holders from refrigerated storage.
2. Reinstall each product holder into correct slot.
3. Remove splash guard from dispense area.
4. Reinstall center grate under dispensing area.

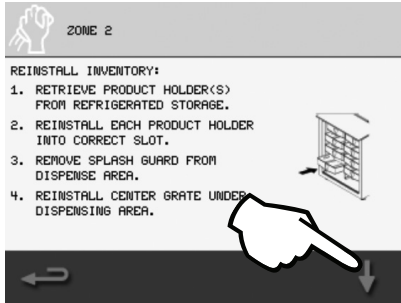

- Press the down arrow to continue.
5. Place a large cup under dispensing nozzles.
  6. Press the green check to continue to the next screen.

**Select Slots to Prime**

- A. Touch each slot that needs to be primed. Only the slots that were selected at the beginning of this sequence and flushed will be available as a choice.
- Selected slots will become highlighted in green.

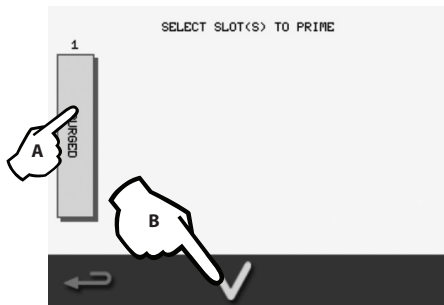

NOTE: If a line that does not have product assigned was cleaned, it will not need priming.

- B. The green check will appear once a slot has been selected. Once all the slots to be primed have been selected, press the green check to continue.

This will automatically prime each line that was selected with product. The screen will read PRIMING SLOT X. Each slot will change from PURGED to PRIMED.

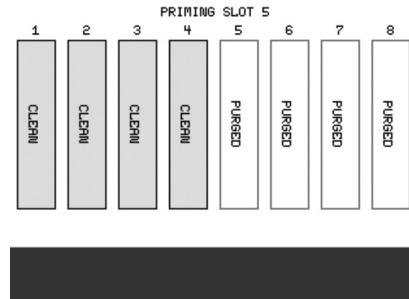

When priming has completed the Prime Complete screen will appear automatically.

**Auto Prime Complete**

1. Remove and dispose of large cup with primed product.

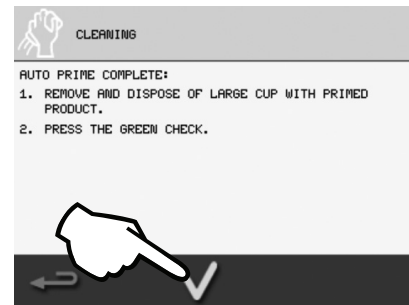

2. Press the green check to continue to the Dispensing Area Cleaning screen.

**Dispensing Area Cleaning**

1. Remove center grate from dispensing area.
2. Spray all dispensing area surfaces with cleaning solution. Then use approved cleaning brush to thoroughly scrub area.\*

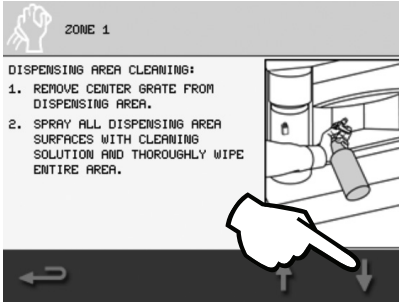

- Press the down arrow to continue.
3. Thoroughly spray each individual dispense nozzle with cleaning solution and apply cleaner to each individual dispensing valve. Then use approved cleaning brush to carefully scrub area.\*
  4. Thoroughly wipe all dispense valves and dispense area with a clean towel.
- Press the down arrow to continue.

**Dispensing Area Sanitizing**

1. Thoroughly spray each individual dispensing nozzle with sanitizer solution.
2. Thoroughly spray dispense area with sanitizer solution.
3. Allow to air dry.
4. Do not wipe off sanitizer!

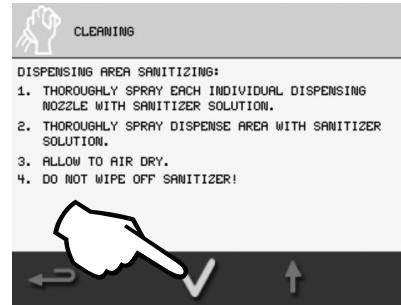

- Press the green check to continue.

**Product Line Flush Completed**

1. Take dispense area grate to sink to wash and sanitize.
2. Reinstall dispense area grate.
3. Remove gloves and safety glasses.\*
4. Return supplies to cleaning kit.

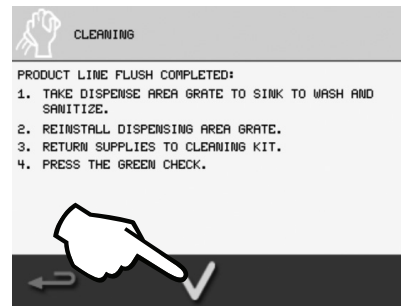

5. Press the green check to complete Product Line Flush. The screen will return to the Main Menu.

## Annual Planned Maintenance

The following parts are recommended for annual planned maintenance replacement to ensure optimum unit performance and minimize downtime:

- Refrigerator door gasket (cleaning may be sufficient)
- (2) #6 O rings for the water and CO<sub>2</sub>/air quick connect lines
- (9) LMS valves
- (1 Or 2) Mixer assemblies
- Ice Dispense Wheel

The parts listed below should be inspected at least once a year or every 10,000 hours of operation. Their service life, however, depends on water quality and environment. More frequent inspection and maintenance are recommended. To have the optimum performance of this ice maker, the following consumable parts need periodic inspection, maintenance and replacement:

- Extruding Head
- Housing
- Lower Bearing
- Gear Motor
- Auger
- Mechanical Seal

THIS PAGE INTENTIONALLY LEFT BLANK

## Section 5 Troubleshooting

If a problem arises during operation of your Blend-In-Cup Beverage System, follow the checklist below before calling service. Routine adjustments and maintenance procedures are not covered by the warranty.

### Before Calling For Service Checklist

Symptom	Possible Cause	Corrective Action
Display Screen is off or refrigeration system is not running	Fuse blown or circuit breaker tripped.	Replace fuse or reset circuit breaker.
	Power cord unplugged.	Plug in power cord.
	Thermostat set too high.	Set thermostat to lower temperature.
	Main power switch turned off.	Turn main power switch on.
Display screen is on, but does not respond to commands	No recipe installed.	Develop recipe in MenuConnect and transfer to control system with USB drive.
	Control board locked up.	Reboot by disconnecting and reconnecting the main power supply.
Recipe does not dispense correctly	Low CO <sub>2</sub> pressure.	Replace CO cylinder, set regulator to correct pressure. See "System Pressures" on page 11.
	No water supply or Low water pressure.	Restore water supply, set regulator to correct pressure. See "System Pressures" on page 11.
	Product is not installed, is installed incorrectly, or product line is blocked.	Install product, re-install correctly. See "Procedure to Clear Blocked Line" on page 75.
	Ice does not dispense.	Call for service.
Blender does not start when cup is inserted	Blender door is not closed.	Close blender door.
	Blender door switch is not closing.	Call for service.
Compressor runs for long periods or continuously	Excessive amount of warm product placed in cabinet.	Allow adequate time for product to cool down.
	Prolonged door openings or door(s) ajar.	Make sure door(s) are closed when not in use. Avoid prolonged door openings.
	Door gasket(s) not sealing properly.	Check gasket condition. Adjust door or replace gasket if necessary.
	Dirty condenser coil.	Clean the condenser coil.
	Evaporator coil iced over.	Turn unit off and allow coil to defrost. Make sure thermostat is not set too cold. Also, check gasket condition.

Symptom	Possible Cause	Corrective Action
Cabinet temperature is too high	Thermostat set too high.	Set thermostat to lower temperature.
	Evaporator Fan(s) will not operate or fan blade is off or spinning on shaft.	Call for service.
	Excessive amount of warm product placed in cabinet.	Allow adequate time for product to cool down.
	Prolonged door openings or door(s) ajar.	Make sure door(s) are closed when not in use. Avoid prolonged door openings.
	Dirty condenser coil.	Clean the condenser coil.
	Evaporator coil iced over.	Turn unit off and allow coil to defrost. Make sure thermostat is not set too cold. Also, check door gasket condition.
	System low on refrigerant.	Call for service - Service company must locate and repair leak, recover, evacuate and recharge.
	Compressor will not start - hums and trips on overload protector.	Clean the condenser coil. Move cabinet or make other adjustments to gain proper cabinet clearances. See "Clearances" on page 8. Check and correct incoming voltage to cabinet.
Cabinet is noisy	Loose part(s).	Locate and tighten loose part(s).
	Tubing vibration.	Ensure tubing is free from contact with other tubing or components.
Refrigerator is freezing product	Thermostat is set too low.	Set thermostat to higher temperature. See "Normal Operation" on page 17.

### Procedure to Clear Blocked Line

NOTE: Verify product is available and properly connected before performing this procedure.

1. Fill a squirt bottle with very warm water.
2. Remove product bin.
3. Connect squirt bottle with vinyl tubing to product tube inlet.
4. Select the Inventory icon from the Main Menu.



5. Select the product with the blocked line.

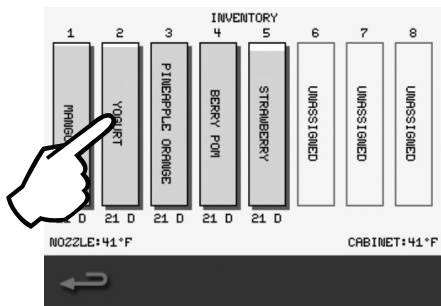

6. Select the green check twice without following the product replacement instructions.



7. Select PRIME FLAVOR.

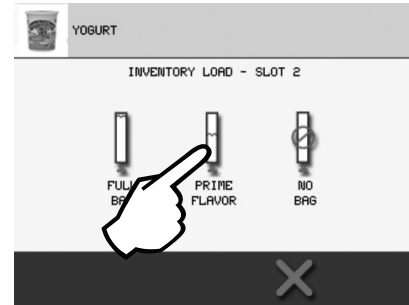

8. Place a cup under dispenser.
9. Select HOLD TO PRIME icon while squeezing the squirt bottle. Watch for product to enter the cup.

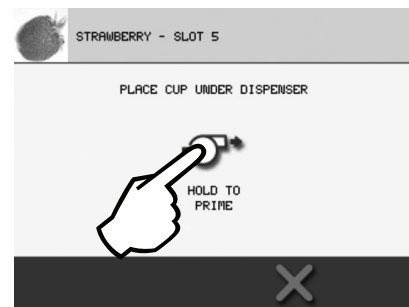

10. Repeat until valve clears, product and/or water enters the cup.
11. Disconnect squirt bottle with vinyl tubing. Insert product bin back into unit.
12. Select HOLD TO PRIME icon until only product flows into cup.
13. Select green check when finished to return to the product Inventory screen.

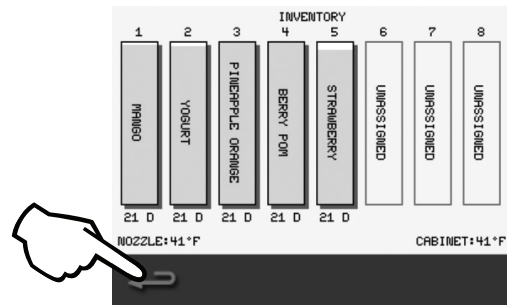

14. Press the return arrow to return to the Main Menu.

### How to Check Air/CO<sub>2</sub> Pressure

- Using the touch screen, go to the Prime Screen, which is accessed through the Inventory icon from the Main Menu.



- On the inventory screen select any assigned product slot.

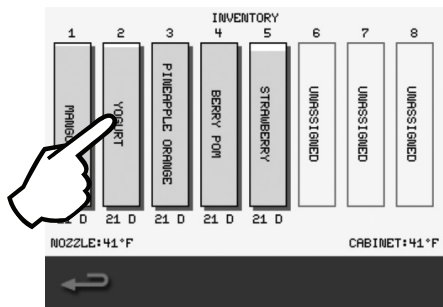

- Select the green check twice without following the product replacement instructions.

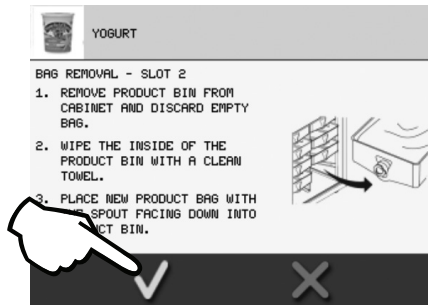

- Select the PRIME FLAVOR icon.

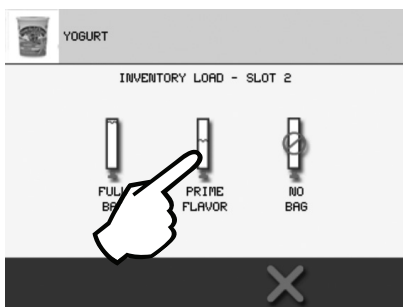

- Place a cup under dispenser.

- Locate the Air/CO<sub>2</sub> regulator on the left side of the unit.

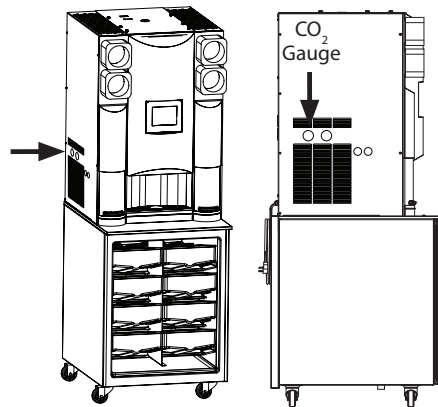

- Press and hold the HOLD TO PRIME icon while checking the CO<sub>2</sub> pressure reading on the regulator on the left side of the unit.

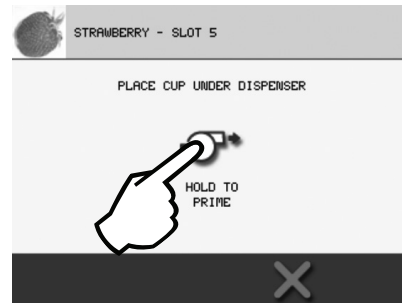

- The regulator will decrease to a stable pressure while the product is priming and then rise back to a higher pressure when the prime button is released.

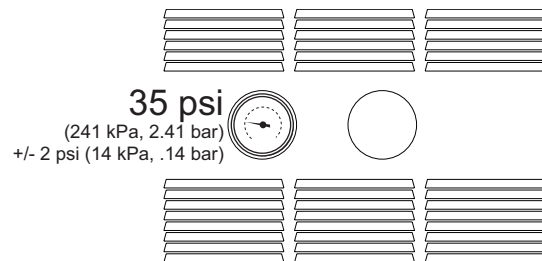

- The regulator should maintain 35 psi (241 kPa, 2.41 bar) +/- 2 psi (14 kPa, .14 bar) under flowing conditions.

- If the Air/CO<sub>2</sub> regulator fails to maintain this pressure during flowing conditions, call service to adjust.

NOTE: To save product, Air/CO<sub>2</sub> pressure can be checked during Zone 2 Cleaning or at any time product pumps are in use.

### How to Check Plain Water Pressure

- Using the touch screen, gain access to the Blend Chamber Rinse Button(s) located at the bottom of either the Drink or Flavor Selection screen.

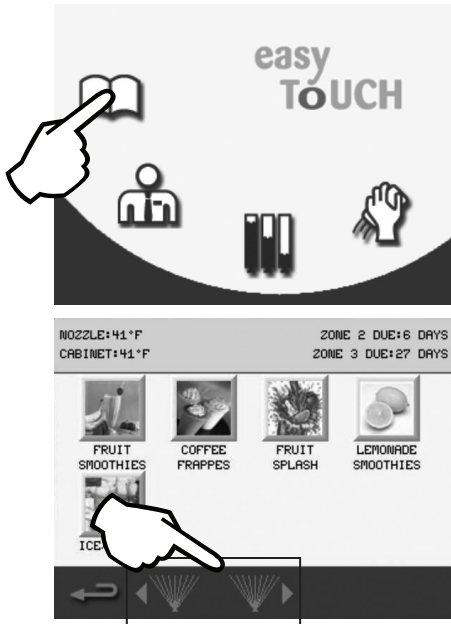

- Activate a rinse cycle by touching the right or left rinse button while reading the plain water regulator on the left side of the unit.

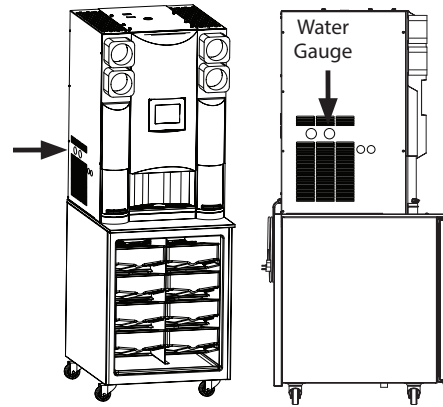

- The regulator will decrease to a stable pressure while the water is flowing and then rise back to a higher pressure once the rinse completes.

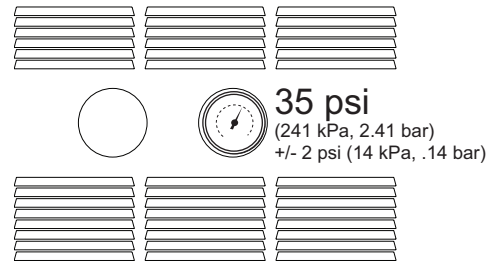

- The regulator should maintain 35 psi (241 kPa, 2.41 bar) +/- 2 psi (14 kPa, .14 bar) under flowing conditions.
- If the plain water regulator fails to maintain this pressure during flowing conditions, call service to adjust.

---

## Tools & Cleaning Supplies

### Cleaning Kits

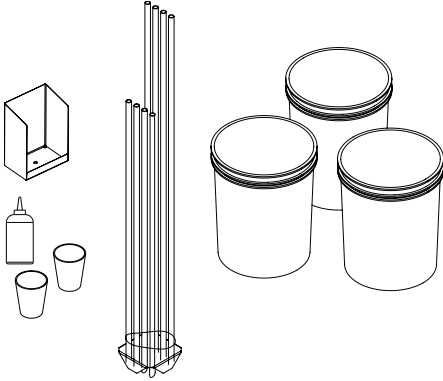

Complete cleaning kits are available for single spindle (part number 000-BIC-001R) and dual spindle (part number 000-BIC-001Q) units. These kits include the following;

- (3) three 5 gallon buckets
- Bucket labels for Wash, Rinse, & Sanitizing
- Red & Blue cups for blender cleaning
- Squeeze Bottle
- Dispense Area Shield
- Tubing Manifold for product line cleaning

## Limited Warranty

### WHO IS COVERED

This Limited Warranty is available only to the original end user of the product and is not transferable.

### Exclusions From Coverage

This warranty shall not apply to:

- Any part or assembly that has been altered, modified, or changed.
- Repair or replacement of parts or assemblies required because of misuse, abuse, improper care or storage, negligence, alteration, accident, use of incompatible supplies or lack of specified maintenance.
- Normal maintenance items, including but not limited to, light bulbs, fuses, containers, gaskets, LMS Valves or product stickers used in the unit, O-rings, interior and exterior finishes, lubrication, de-liming, broken glass, etc.
- Improper or unauthorized repair.
- Failures caused by improper or erratic voltages.
- Any parts subject to damage beyond the control of Company, or to equipment which has been subject to alteration, misuse or improper installation, accidents, damage in shipment, fire, floods, power changes, other hazards or acts of God that are beyond the control of Company.
- Any machine that has been installed and/or maintained inconsistent with the technical instructions provided by the Company.
- Any machine initially installed more than five years from the serial number production date.
- Any products or equipment manufactured or sold by Company when such products or commercial equipment is installed or used in a residential or non-commercial application. Installations not within the applicable building or fire codes render this Limited Warranty and any responsibility or obligations associated therein null and void. This includes any damage, costs or legal actions resulting from the installation of any Company equipment in a non-commercial application or installation, where the equipment is being used for applications other than those approved for by Company.
- Any product cleaned without using an approved Company cleaning solution shall void this Limited Warranty.
- This warranty shall not apply if the Machine's refrigeration system is modified with a condenser, heat reclaim device, or parts and assemblies other than those manufactured by the Company, unless the Company approves these modifications for specific locations in writing.

## LIMITATIONS OF LIABILITY

The preceding paragraphs set forth the exclusive remedy for all claims based on failure of, or defect in, products or services sold hereunder, whether the failure or defect arises before or during the warranty period, and whether a claim, however instituted, is based on contract, indemnity, warranty, tort (including negligence), strict liability, implied by statute, common-law or otherwise, and Company its servants and agents shall not be liable for any claims for personal injuries or consequential damages or loss, howsoever caused. Upon the expiration of the warranty period, all such liability shall terminate. THE FOREGOING WARRANTIES ARE EXCLUSIVE AND IN LIEU OF ALL OTHER WARRANTIES, WHETHER WRITTEN, ORAL, IMPLIED OR STATUTORY. NO IMPLIED WARRANTY OF MERCHANTABILITY OR FITNESS FOR PARTICULAR PURPOSE SHALL APPLY. COMPANY DOES NOT WARRANT ANY PRODUCTS OR SERVICES OF OTHERS.

### Remedies

The liability of Company for breach of any warranty obligation hereunder is limited to: (i) the repair or replacement of the Machine on which the liability is based, or with respect to services, re-performance of the services; or (ii) at Company's option, the refund of the amount paid for said Machine or services. Any breach by Company with respect to any item or unit of equipment or services shall be deemed a breach with respect to that item or unit or service only.

### WARRANTY CLAIM PROCEDURE

Customer shall be responsible to:

- Immediately advise the Company's Authorized Service Agent of the equipment serial number and the nature of the problem.
- Verify the problem is a factory responsibility.
- Cooperate with the Service Agency so that warranty service may be completed during normal working hours.

To secure prompt and continuing warranty service, the warranty registration card must be completed and sent to the COMPANY within five (5) days from the installation date.

### GOVERNING LAW

For equipment, products and services sold in the United States, this Limited Warranty shall be governed by the laws of the state of Delaware, USA, excluding their conflicts of law principles. The United Nations Convention on Contracts for the International Sale of Goods is hereby excluded in its entirety from application to this Limited Warranty.



MULTIPLEX  
2100 FUTURE, SELLERSBURG, IN 47172

800-367-4233  
WWW.MANITOWOCBEVERAGE.COM/US

Every new piece of Manitowoc Foodservice equipment comes with KitchenCare™ and you choose the level of service that meets your operational needs from one restaurant to multiple locations.

**StarCare** – Warranty & lifetime service, certified OEM parts, global parts inventory, performance audited

**ExtraCare** — CareCode, 24/7 Support, online/mobile product information

**LifeCare** – Install & equipment orientation, planned maintenance, KitchenConnect™, MenuConnect

**Talk with KitchenCare™** • 1-844-724-CARE • [www.mtwkitchencare.com](http://www.mtwkitchencare.com)



To learn how Manitowoc Foodservice and its leading brands can equip you, visit our global web site at [www.manitowocfoodservice.com](http://www.manitowocfoodservice.com), then discover the regional or local resources available to you.

