

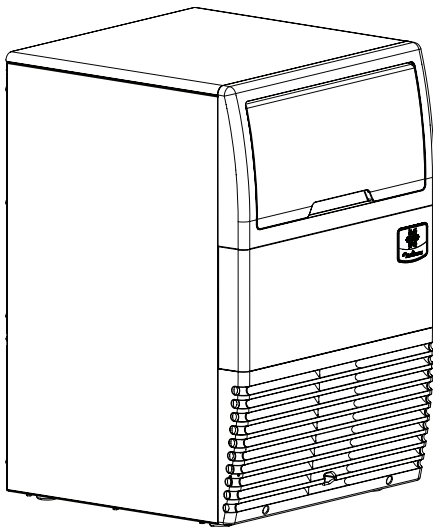

UnderCounter Ice Machines

UG Series

Technician's Handbook



Safety Notices

Read these precautions before any operation:

- Read this manual thoroughly before operating, installing or performing maintenance on the equipment. Failure to follow instructions may result in personal injury and damage to the ice machine.
- Routine adjustments, maintenance and cleaning procedures outlined in this manual are not covered by the warranty.
- Proper installation, care and maintenance are essential for maximum performance and trouble-free operation of your equipment.
- For the latest version, translated manual or service provider information, please visit the following website: www.manitowocice.com
- This equipment contains high voltage electricity and refrigerant charge. Installation and repairs are to be performed by properly trained technicians aware of the dangers of dealing with high voltage electricity and refrigerants under pressure. The technicians must also be certified in proper refrigerant handling and servicing procedures. All lockout and tag out procedures must be followed when working on this equipment.
- This equipment is intended for indoor use only. Do not install or operate this equipment in outdoor areas.
- As you work on this equipment, be sure to pay close attention to the safety notices in this handbook. Disregarding the notices may lead to serious injury and/or damage to the equipment.

Definitions

DANGER

Indicates a hazardous situation that, if not avoided, may result in death or serious injury. This applies to the most extreme situations.

Warning

Indicates a hazardous situation that, if not avoided, may result in death or serious injury.

Caution

Indicates a hazardous situation which, if not avoided, may result in minor or moderate injury.

Caution

Indicates information considered important, but not hazard related (e.g. messages relating to property damage).

NOTE: Indicates useful and extra information about the procedure you are performing.

Warning

Follow these electrical requirements during installation of this equipment:

- All field wiring must conform to all applicable codes of the authority having jurisdiction. It is the responsibility of the end user to provide the disconnect means to satisfy local codes. Refer to rating plate for proper voltage.
- This appliance must be connected and grounded in accordance with state and local electrical codes.
- This equipment must be positioned so that the plug is accessible unless other means for disconnection from the power supply (e.g., circuit breaker or disconnect switch) is provided.
- Check all wiring connections, including factory terminals, before installation. Connections can become loose during shipment and installation.
- For a cord-connected appliance, the following must be included:
 - Do not unplug by pulling on cord. To unplug, grasp the plug, not the cord.
 - Unplug from outlet when not in use and before servicing or cleaning.
 - Do not operate any appliance with a damaged cord or plug, or after the appliance malfunctions or is dropped or damaged in any manner. Contact the nearest authorized service facility for examination, repair, or electrical or mechanical adjustment

 **DANGER**

Do not operate equipment that has been misused, abused, neglected, damaged, or altered/modified from that of original manufactured specifications. This appliance is not intended for use by persons (including children) with reduced physical, sensory or mental capabilities, or lack of experience and knowledge, unless they have been given supervision concerning use of the appliance by a person responsible for their safety. Do not allow children to play with, clean or maintain this appliance without proper supervision.

Warning

Follow these precautions to prevent personal injury during installation of this equipment:

- Installation must comply with all applicable equipment, fire and health codes with the authority having jurisdiction.
- Connect to a potable water supply only.
- To avoid instability, the installation area must be capable of supporting the combined weight of the equipment and product. Additionally the equipment must be level side to side and front to back.
- Remove all movable panels before lifting and installing and use appropriate safety equipment during installation and servicing. Two or more people are required to lift or move this appliance to prevent tipping and/or injury.
- Do not damage the refrigeration circuit when installing, maintaining or servicing the unit.
- This equipment contains high voltage electricity and refrigerant charge. Only refrigeration technicians who have received appropriate training and certification, and are aware of the dangers of handling refrigerants and energized equipment, are allowed to complete the installation and maintenance of this equipment.
- The ice machine is installed on a bin and requires a deflector. If it is installed on a third-party ice bin, please consult the bin manufacturer to verify that its deflector matches your ice machine before installing.
- Before installing the third-party bin, please follow the manufacturer's installation procedures and verify that its position and installation meet the local/national mechanical codes and stability requirements.

Warning

Follow these precautions to prevent personal injury during use and maintenance of this equipment:

- It is the responsibility of the end user to perform a Personal Protective Equipment Hazard Assessment to ensure adequate protection during maintenance procedures.
- Do not store or use gasoline or other flammable vapors or liquids in the vicinity of this or any other appliance. Never use flammable oil-soaked cloths or combustible cleaning solutions for cleaning.
- All covers and access panels must be in place and properly secured when operating this equipment.
- Risk of fire/shock. All minimum clearances must be maintained. Do not obstruct vents or openings.
- Failure to disconnect power at the main power supply disconnect could result in serious injury or death. The power switch does not disconnect all incoming power.
- All utility connections and fixtures must be maintained in accordance with the authority having jurisdiction.
- Turn off and lockout all utilities (gas, electric, water) according to approved practices during maintenance or servicing.
- Units with two power cords must be plugged into individual branch circuits. During movement, cleaning or repair, it is necessary to unplug both power cords.

- Do not use high-pressure water guns to spray or rinse the interior or exterior of the unit. Do not use power cleaning equipment, steel wool, wire brushes, scrapers, etc. to clean the exterior of the equipment.
- To prevent tipping, two or more people are needed to move this appliance.
It is the responsibility of the end user to lock the front casters after the device has been moved. When casters are installed the mass of this unit will allow it to move uncontrolled on an inclined surface. These units must be tethered/secured to comply with all applicable codes.
- It is the responsibility of the site supervisor to ensure that operators fully understand the dangers inherent in operating this equipment.
- Do not operate any equipment with damaged cords or plugs. All repairs must be performed by a qualified service company.
- Moisture collecting on the floor will create a slippery surface. Clean up any water on the floor immediately to prevent a slip hazard.

Warning

When installing, using, or servicing this equipment, follow these flammable refrigeration system requirements.

- Refer to the nameplate - The ice machine may contain up to 150 grams of R290 (propane) refrigerant. R290 (propane) is flammable in concentrations of air between approximately 2.1% and 9.5% by volume. R290 (propane) may burn if exposed to a heat source above 470 °C. Refer to nameplate to identify the type of refrigerant in your equipment.
- To reduce the risk of fire due to improper installation, replacement of parts, or improper use of procedures, only refrigeration technicians trained in flammable refrigerants who understand the dangers of high voltage electricity and refrigerants under pressure are allowed to work on this equipment.
- Only use parts recommended or provided by the manufacturer.
- This equipment must be installed in accordance with ASHRAE 15 refrigeration system's safety standards.
- This equipment cannot be installed in a corridor or hallway of a public building.
- Equipment installation must comply with local sanitation and fire regulations.
- When servicing this equipment, be sure to lock the circuit breaker, and display an in-service notice.
- This device contains a high-voltage power supply and refrigerant charge. Shorting wires to the cooling system piping may cause an explosion. Before servicing the system, be sure to disconnect all power to the system. Refrigerant leakage can result in serious injury or death from explosion, fire, or contact with refrigerant or lubricant mist.
- Do not damage the refrigeration circuit when installing, maintaining or servicing the unit.

Warning

Follow these precautions to prevent personal injury while operating or maintaining this equipment:

- Refer to nameplate to identify the type of refrigerant in your equipment.
- Only trained and qualified personnel aware of the dangers are allowed to work on the equipment.
- Read this manual thoroughly before operating, installing or performing maintenance on the equipment. Failure to follow instructions in this manual can cause property damage, injury or death.
- Crush/Pinch Hazard. Keep hands clear of moving components. Components can move without warning unless power is disconnected and all potential energy is removed.
- Moisture collecting on the floor will create a slippery surface. Clean up any water on the floor immediately to prevent a slip hazard.
- Never use sharp objects or tools to remove ice or frost. Do not use mechanical devices or other means to accelerate the defrosting process.
- When using cleaning fluids or chemicals, rubber gloves and eye protection (and/or face shield) must be worn.

PAGE INTENTIONALLY LEFT BLANK

Table of Contents

General Information

Model Numbers	17
This manual covers the following ice machine models:	17
How to Read A Model Number	18
Model/Serial Number Location	19
Warranty	20
Warranty Registration	20

Installation

General	21
Ice Machine Dimensions	21
Location of Ice Machine	22
Leveling the Ice Machine	23
Cooling of the Ice Machine	23
Water Service/Drains	24
Electrical Service	26
Voltage	26
Fuse/Circuit Breaker	26
Total Circuit Ampacity	26
Installation Checklist	28
Before Starting the Ice Machine	29

Operation

Component Identification	31
Ice Making Sequence of Operation	32
Initial Start-up	32
Operational Checks	34
General	34
Cube Shape	34
Ice Cube Thickness Check	35

Maintenance

General	36
Cleaning/Descaling & Sanitizing Procedure	37
Exterior Cleaning	38
Detailed Descaling & Sanitizing Procedure	39
Component Removal	43
Top Cover	43
Water Curtain	44
Water Shutters	45
Water Curtain	45
Ice Chute	46
Spray Bar	47
Sump Drain Overflow Tube	48
Cleaning the Condenser	49
Air-Cooled Condenser	49
Removal from Service/Winterization	50
Air-Cooled Ice Machines	50

Troubleshooting

Questions to Ask The Customer	51
Ice Machine Will Not Run	52
Compressor Won't Run	52
Water Pump Won't Run	56
Ice Machine Prematurely Harvests	57
Ice Machine Will Not Harvest	57
Water System Checklist	58
Ice Production Check	59
Analyzing Discharge Pressure	61
Discharge Pressure High Checklist	62
Freeze Cycle Discharge Pressure Low Checklist ..	62
Suction Pressure High Checklist	63
Suction Pressure Low Checklist	64
Discharge Line Temperature Analysis	65

Component Check Procedures

Electrical Components	67
ON/OFF/Wash Toggle Switch	67
Bin Thermistor (T3)	68
Sump Water Thermistor (T1) & Liquid Line Thermistor (T2)	70
Hot Gas Valve	77

Flammable Refrigerant Procedures

Servicing Requirements	81
Refrigerant Purging Requirements	82
Refrigerant Purging Procedure	83
Brazing Procedure	83
Pressure Testing	84
Evacuation	84
Refrigerant Charging	85
System Contamination Cleanup	87
Determining Severity of Contamination	87
Mild System Contamination Cleanup Procedure	89
Severe System Contamination Cleanup Procedure	90

Charts

Cycle Times/24-Hour Ice Production/Refrigerant

Pressure Charts	93
UGP020 Self-Contained Air-Cooled	94
UGP020 Operating Temperatures	95
UGP030 Self-Contained Air-Cooled	96
UGP030 Operating Temperatures	97
UGP040 Self-Contained Air-Cooled	98
UGP040 Operating Temperatures	99
UGP080 Self-Contained Air-Cooled	100
UGP080 Operating Temperatures	101
UGE0030A Self-Contained Air-Cooled	103
UGF0040A Self-Contained Air-Cooled	104
UGF0050A Self-Contained Air-Cooled	105
UGF0065A Self-Contained Air-Cooled	106
UGF0080A Self-Contained Air-Cooled	107

Wiring Diagrams

Wiring Diagrams	109
Wiring Diagram Legend	109
UGE0020A Air-Cooled	110
UGP0020A Air-Cooled	112
UGE0030A/UGF0040A/UGF0050A/UGF0065A Air-Cooled	114
UGP0030A/UGP0040A/UGP0050A Air-Cooled	116
UGF0080A Air-Cooled	118
UGP0080A Air-Cooled	120
Tubing Schematics	122
UG0020A	122
UG0030A/UG0040A/UG0065A	123
UG0050A/UG0080A	124

General Information

Model Numbers

THIS MANUAL COVERS THE FOLLOWING ICE MACHINE MODELS:

Self-Contained Air-Cooled	
UGE0020A	UGP0020A
UGE0030A	UGP0030A
UGF0040A	UGP0040A
UGF0050A	UGP0050A
UGF0065A	----
UGF0080A	UGP0080A

NOTE: The model suffix is used to identify the voltage, special model, or country-specific model. See “How to Read A Model Number” on Page “How to Read A Model Number” on page 18.

How to Read A Model Number

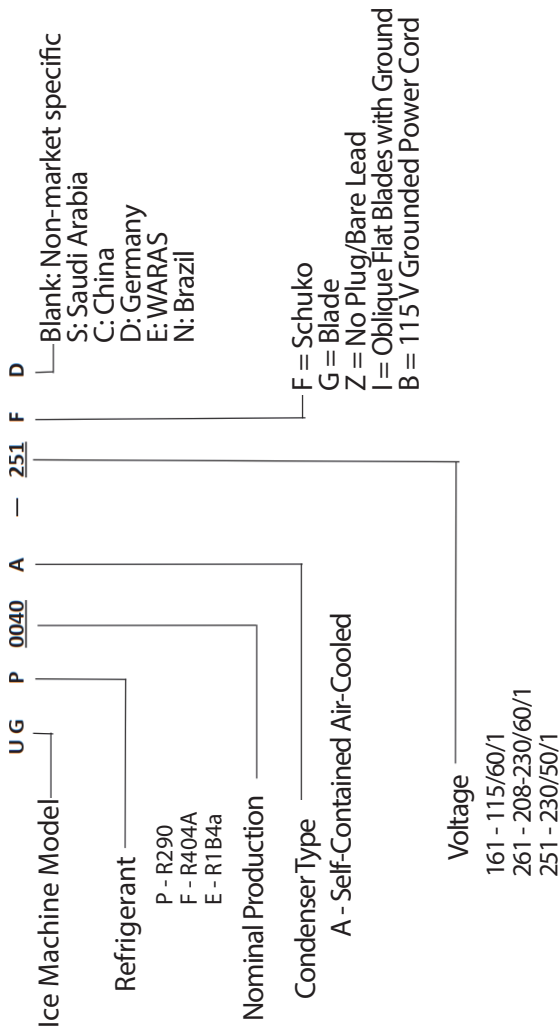

Model/Serial Number Location

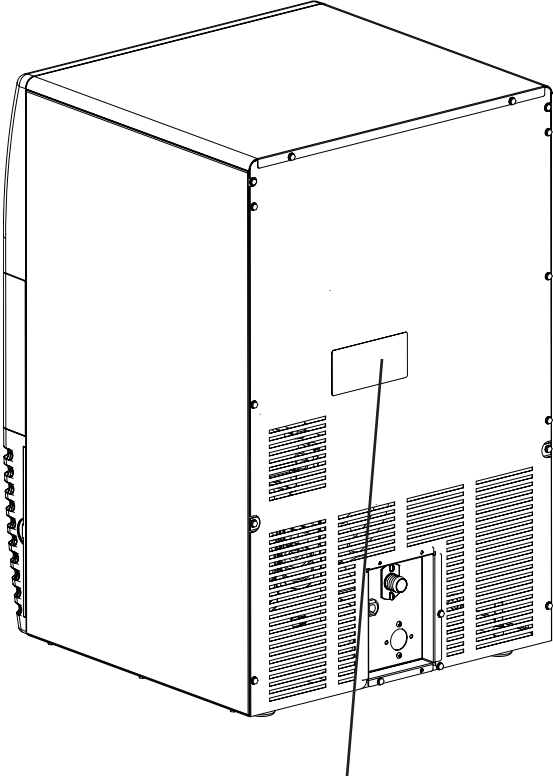

Model/Serial Number Location

Warranty

For warranty information visit:

www.manitowocice.com/Service/Warranty

- Warranty Coverage Information
- Warranty Registration
- Warranty Verification

Warranty coverage begins the day the ice machine is installed.

WARRANTY REGISTRATION

Completing the warranty registration process is a quick and easy way to protect your investment.

Scan the QR code with your smart device or enter the link in a web browser to complete your warranty registration.



WWW.MANITOWOCICE.COM/SERVICE/WARRANTY#WARRANTY-REGISTRATION

Registering your product insures warranty coverage and streamlines the process if any warranty work is required.

Installation

General

These instructions are provided to assist the qualified installer.

Ice Machine Dimensions

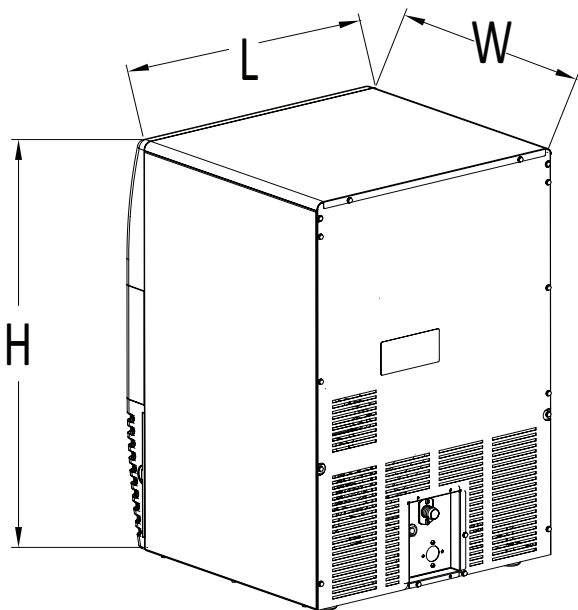

Model		L	W	H
UG0020	mm	450	475	650
UG0030	mm	450	475	650
UG0040	mm	550	550	800
UG0050	mm	550	550	800
UG0065	mm	700	600	902
UG0080	mm	700	600	902

Location of Ice Machine

The location selected for the ice machine must meet the following criteria. If any of these criteria are not met, select another location.

1. The location must be indoors and free from airborne and other contaminants.
2. The ambient temperature must be higher than 50 °F (10 °C) and must be lower than 110 °F (43 °C).
3. Water inlet lines - water pressure to the machine must be above 20 psi (1.38 bar) and below 80 psi (5.52 bar).
4. The location must not be near heat-generating equipment or in direct sunlight.
5. The location must be capable of supporting the weight of the ice machine and a full bin of ice.
6. The location must not obstruct airflow through or around the ice machine. Refer to the chart below for clearance recommendations:

Self-Contained Air-Cooled	
Top/Sides	8"(203mm)*
Back	5"(127mm)*
*There is no minimum clearance requirement for the top or left and right sides of the ice machine. The listed values are recommended for efficient operation and servicing only.	

NOTE: The ice machine may be built into a cabinet.

Caution

The ice machine must be protected if it will be subjected to temperatures below 32 °F (0 °C). Failure caused by exposure to freezing temperatures is not covered by the warranty. See "Removal from Service/Winterization".

Leveling the Ice Machine

1. Screw the legs or levelers into the bottom plate of the ice machine.
2. Screw the foot of each leg or leveler in as far as possible. Move the ice machine into its final position.
3. Use a level on top of the ice machine. Turn each foot as necessary to level the ice machine from front to back and side to side.

Cooling of the Ice Machine

Ice Machine Model	Cooling	
	Air conditioning*	Peak
UG0020	1400	2600
UG0030	1900	3300
UG0040	2100	4100
UG0050	2600	5000
UG0065	2900	5000
UG0080	4300	7400

*BTU/Hour

The amount of heat dissipated varies during the ice making cycle. The listed values are average values.

Water Service/Drains

Drinking Water Supply

According to the local water quality, determine whether it is necessary to install a water treatment system to avoid the formation of sediment and to filter out impurities and remove the smell of bleaching powder.

Important

When installing a Manitowoc water filtration system, be sure to follow the instructions provided with the filtration system for pipe installation.

Follow these guidelines to install the water inlet lines:

1. Water temperature must be between 50 °F (10 °C) and 90 °F (32 °C). Be sure all hot water restrictors installed for other equipment are working (Check valves on sink faucets, dishwashers, etc.).
2. Water pressure to the machine should be between 20 to 80 psi (140 to 550 kPa).
3. The minimum inner diameter of the pipe is 1/2" (15 mm).

Drain Connections

- Drain lines must have a 1.5 inch (3.8 cm) drop of run for each meter (3 feet), and must not create traps.
- The floor drain must be large enough to accommodate drainage from all drains.
- Run separate bin and water-cooled condenser drain lines.
- Insulate them to prevent condensation by temperature.
- Install a tee to vent the ice machine drain to the atmosphere.
- Appropriate air gaps must be installed for all drain terminations as per the applicable specifications.

Water Supply and Drain Line Sizing/Connections

	Ice Making Water Inlet	Drain Connection Outlet
Inlet water temperature	50°F (10°C) Min. 90°F (32°C) Max.	--
Inlet Water Pressure	20 psi (140 kPa) Min. 80 psi (550 kPa) Max.	--
Ice Machine Fitting	3/4" male pipe thread	7/8" fitting barbed
Tubing Size Up to Ice Machine Fitting	1/2" (15mm) minimum inner diameter	3/4" (18mm) minimum inner diameter

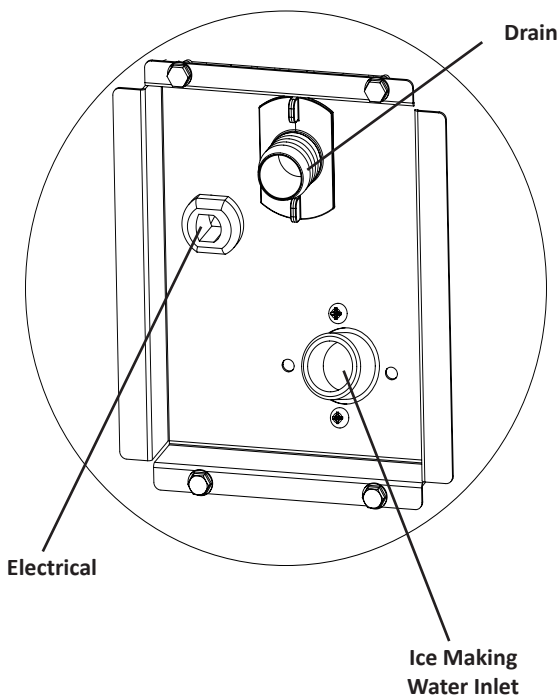

Electrical Service

Warning

The ice machine must be grounded in accordance with national and local electrical codes. Do not use any extension cords. If the supplied power cord is not long enough to reach the socket, a designated socket should be installed close to the ice machine.

VOLTAGE

The maximum allowable voltage variation is $\pm 6\%$ of the rated voltage at start-up of the ice machine's compressor.

All ice machines are factory pre-wired with a 2 meter (6 ft) power cord, and no plug is supplied.

FUSE/CIRCUIT BREAKER

A separate fuse/circuit breaker must be provided for each ice machine.

TOTAL CIRCUIT AMPACITY

The total circuit ampacity is used to determine the wire size of the power supply line.

The wire size (or gauge) is also dependent upon location, materials used, length of run, etc. This must be determined by a qualified electrician.

Ice Machine	Voltage/Phase/Cycle	Maximum Fuse/Air Switch Specifications	Total Circuit Ampacity
UG0020	220/1/50	10	2.3
	220/1/60	10	2.3
UG0030	220/1/50	15	2.8
	220/1/60	15	2.8
	115/1/60	15	5.5
UG0040	220/1/50	15	3.0
	220/1/60	15	3.0
UG0050	220/1/50	15	4.0
	220/1/60	15	4.0
	115/1/60	15	6.8
UG0065	220/1/50	15	4.5
	220/1/60	15	4.5
UG0080	220/1/50	15	5.5
	220/1/60	15	5.5

Warning

Risk of Electric Shock - For hard wired (wired without a plug) machine, it must be properly grounded and connected to the field wiring terminal in accordance with all applicable national and local electrical codes by a qualified electrician. Before connecting wires, disconnect power at the electrical disconnect and lock out to prevent accidentally energizing. Connect all electrical wiring before use—do not energize ice machine until installation is complete.

1. Wiring – Connect the three supply lead wires (Blue, Brown, and Yellow/Green) to the field wiring terminal, “L”, “N”, and “G”, and the Yellow/Green wire must connect to the “G” (ground).
2. After connecting the wiring to the terminal strip, the supply lead must be secured to the cabinet with a strain relief near the terminal strip.
3. Verify wiring is contained in the electrical wiring box.

Installation Checklist

- Is the ice machine level?
- Has all the inner packaging been removed?
- Have all of the electrical and water connections been made?
- Has the supply voltage been tested and checked against the rating on the nameplate?
- Are all components installed?
- Has the ice machine been installed where ambient temperatures will remain in the range of 50 °F - 110 °F (10 °C - 43 °C)?
- Has the ice machine been installed where the incoming water temperature will remain in the range of 50 °F - 90 °F (10 °C - 32 °C)?
- Are all electrical leads free from contact with refrigeration lines and moving equipment?
- Has the owner/operator been instructed regarding maintenance and the use of Manitowoc Cleaner and Sanitizer?
- Has the owner/operator completed the warranty registration?
- Has the ice machine and bin been sanitized?
- Has this manual been given to the owner/operator?
- Is the on-off-wash switch set to the ON position?

Before Starting the Ice Machine

All Manitowoc ice machines are factory-operated and adjusted before shipment. Normally, new installations do not require any adjustment.

To ensure proper operation, follow the Operational Checks as specified in Section 3. Completing the Operational Checks is the responsibilities of the owner.

Adjustments and maintenance procedures outlined in this manual are not covered by the warranty.

Warning

Personal Injury Potential - Do not operate equipment that has been misused, abused, neglected, damaged, or altered/modified from that of original manufactured specifications.

PAGE INTENTIONALLY LEFT BLANK

Operation

Component Identification

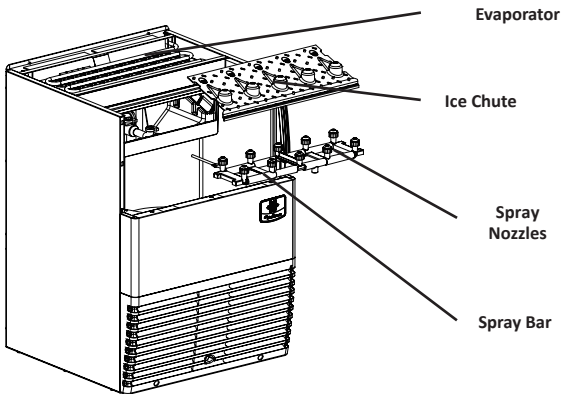
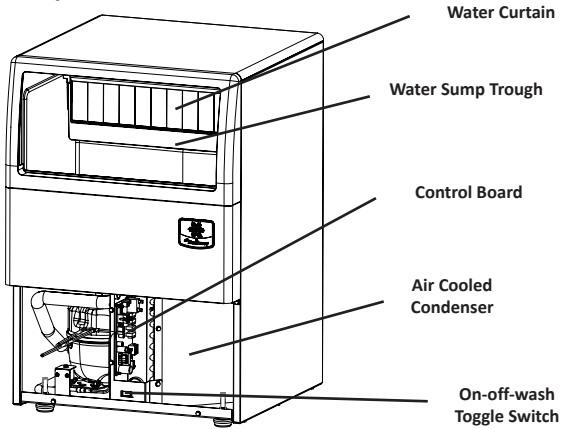

Ice Making Sequence of Operation

INITIAL START-UP

1. Water Inlet and Pressure Equalization

Turn the toggle switch to the “ON” position, the water fill valve and harvest valve are energized, and 300 seconds later, the water fill valve is de-energized. 20 seconds after the harvest valve solenoid is energized, the compressor is energized. 300 seconds after the compressor is energized, the harvest valve solenoid is de-energized, the water pump and the fan motor are energized, and the machine goes into freeze cycle.

2. Freeze Cycle

As the ice making process begins, the pump sprays water into the inverted cups. The water freezes layer by layer, until an ice cube forms in each cup.

When the water temperature in the sump is equal to or less than 2 °C for more than 5 seconds, the control board will read the settings of “liquid line temperature” and dip switch and obtain the “freeze postpone time” and “fan shut off time”. Before the end of the freeze cycle, the control board may shut off the fan motor to assist harvest. When the “freeze postpone time” has elapsed, the harvest cycle is initiated.

3. Harvest Cycle

The compressor continues to operate and the water pump is de-energized. The hot gas valve energizes, allowing hot refrigerant vapor to enter and warm the evaporator. The water valve is also energized, aiding with harvest, as well as filling up the sump with fresh water for a new freeze cycle.

At the point of 2 minutes to freeze end, the board will read the “liquid line temperature” again and calculate the “harvest time”.

The ice falls from the cups and is directed into the bin by the ice chute. The harvest cycle continues until the “harvest time” has elapsed, and then the machine goes into a new freeze cycle.

4. Automatic Shut-Off

When the storage bin is full, the ice will come in contact with the bin thermostat which is located inside the bin. The machine will stop after approximately 45 seconds of continuous ice contact with the bin thermostat probe.

The ice machine remains off until a 3 minute delay has elapsed and enough ice has been removed from the storage bin to allow the ice to fall clear of the bin thermostat probe. As the ice clears the probe, the bin thermostat warms up to above the set value and the machine starts another freeze cycle.

Operational Checks

GENERAL

Your ice machine was factory-operated and adjusted before shipment. Normally, a newly installed ice machine does not require any adjustment.

To ensure proper operation, always follow these Operational Checks when starting the ice machine:

- for the first time;
- after a prolonged out of service period;
- after cleaning and sanitizing.

Routine adjustments and maintenance procedures outlined in this manual are not covered by the warranty.

Important

It is recommended that adjustments made to this ice machine be made by a qualified technician. Improper adjustment may seriously affect the life of this ice machine.

CUBE SHAPE

The standard cube has an average weight of 19 grams. Notice the normal dimple in the center of the cube.

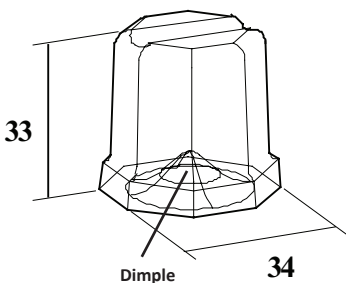

ICE CUBE THICKNESS CHECK

The ice cube thickness is factory-set to maintain the ice cube thickness at the proper size and weight. Check and adjust according to the following steps:

1. Allow the ice machine to operate for three complete cycles. The cubes should have a small dimple in the center.
2. Cycle times vary, according to surrounding air and water inlet temperatures.
3. If cubes are not full (large dimple), raise the DIP switch level to increase the cube size (For example, if the original setting is "0", then pull up the "0" switch and press down the "1" switch). Allow the ice machine to complete three cycles, and then check the cube shape.
4. If cubes are too full (no dimple), lower the DIP switch level to decrease the cube size (For example, if the original setting is "0", then pull up the "0" switch and press down the "-1" switch). Allow the ice machine to complete three cycles, and then check the cube shape.
5. The DIP switch can be adjusted to five levels: -2/-1/0/+1/+2. Ensure that only one level switch is pressed.

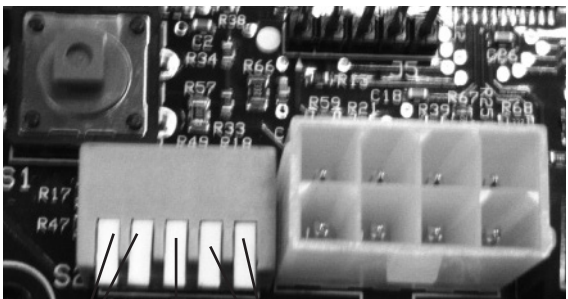

**Decrease
Cube Size**

**Factory
Setting**

**Decrease
Cube Size**

Maintenance

General

The end user is responsible for maintaining the ice machine in accordance with the instructions in this manual. Maintenance procedures are not covered by the warranty.

Cleaning and maintenance of the ice machine can improve its reliability, increase performance, and help save on water and power consumption. Ice production will be maintained within the manufacturer's guidelines, and unwanted repairs due to maintenance issues will be minimized.

If there are heavy scale deposits, consult a qualified water company and ask them to test the water quality and recommend an appropriate water treatment method. A dirty ice machine must be disassembled, descaled, and sanitized.

Manitowoc ice machine cleaner/descaler and sanitizer are the only products approved for use on Manitowoc ice machines.

Caution

Use only Manitowoc approved cleaner/descaler (Part Number [9405463](#)) and sanitizer (Part Number [9405653](#)). Failure to follow the instructions on the label will violate relevant laws. Read and understand all instructions on the package before use.

Caution

Do not mix the cleaner/descaler and sanitizer solutions together. Failure to follow the instructions on the label will violate relevant laws.

Warning

When handling cleaner/descaler and sanitizer, wear rubber gloves and safety goggles (and/or face shield).

Cleaning/Descaling & Sanitizing Procedure

Descale and sanitize the ice machine at least every six months.

- The ice machine and storage bin should be descaled and sanitized separately.
- All ice cubes must be discarded during descaling and sanitizing.
- Remove all mineral deposits in areas in direct contact with water.

The chart below is an overview of the maintenance that the end user and service technician should perform, and the frequency. These figures are the minimum required. If the ice machine is supplied with hard water, more frequent evaporator cleaning should be performed. If the condenser air filter is totally blocked after one week, more frequent cleaning is recommended.

Maintenance	Weekly	Monthly	Semi Annual	Annual	After prolonged shutdown	At start-up
Clean Cabinet Exterior	X				X	X
Sanitize Ice Bin			X		X	X
Descal Evaporator			X	S	S	
Sanitize Evaporator			X	S	S	S
Clean Condenser Coil			X	S	S	
Check Ice Quality	X			S	S	S

X=End User

S=Service Company

EXTERIOR CLEANING

Clean the area around the ice machine as often as necessary to maintain cleanliness and efficient operation.

Wipe any dust and dirt off the surface of the ice machine with a damp cloth, and wipe any oil off with a cloth dampened with a soap solution. Wipe dry with a clean, soft cloth.

- Do not use a wire brush or coarse cloth for cleaning.
- Do not wipe the surface with products containing chlorine or abrasives.

Detailed Descaling & Sanitizing Procedure

Caution

Use only Manitowoc approved cleaner/descaler (Part Number [9405463](#)) and sanitizer (Part Number [9405653](#)). Failure to follow the instructions on the label will violate relevant laws. Read and understand all instructions on the package before use. Do not mix the cleaner/descaler and sanitizer solutions together. Failure to follow the instructions on the label will violate relevant laws.

Warning

When handling cleaners and sanitizers, wear rubber gloves and safety goggles (and/or face shield).

Cleaner/descaler is used to remove lime scale or other mineral deposits. Sanitizer is used to remove algae or slime.

Step 1 Set the toggle switch to the OFF position at the end of a harvest cycle, after ice releases from the evaporator. Or, set the switch to the OFF position and allow the ice to melt off the evaporator.

Caution

Never use anything to force ice from the evaporator. Damage may result.

Step 2 Remove all ice from the bin.

Step 3 Remove all parts as described in “Component Removal” on page 43.

Step 4 Mix 4 liters of water with 500 ml of cleaner/descaler in a plastic or stainless steel container to prepare a cleaning solution.

Cleaner/Descaler	Water
500 ml (16 oz)	4 L (1 gal)

Step 5 Take all components to sink and with 2 liters descaler/water mixture, descale all components with a soft nylon brush. Disassemble the spray bar, remove nozzles and inserts and soak for 5 minutes. For heavily scaled parts, soak in the solution for 15-20 minutes. Rinse all components with clean water.

Step 6 While components are soaking, use a nylon brush to scrub the inside of the ice bin. Scrub inside of the door, door track, bin, sump trough and evaporator moldings. With clean water, rinse all of these areas thoroughly.

Step 7 Replace the sump overflow tube and pour remaining 2 liters of mixture into the water sump. Replace all other parts.

Step 8 To start a cleaning cycle, press the toggle switch to the WASH position and hold for 5 seconds.

Step 9 Wait until the clean cycle is complete (approximately 13.5 minutes). Remove the water curtain, ice chute and overflow tube from the water sump. Allow all water to drain from the sump. Replace the disassembled parts. Press the toggle switch to the WASH position and hold for 5 seconds to start a 12 minute rinse cycle.

Step 10 After the rinse cycle is complete, remove the water sump overflow tube. Drain water from the sump and replace the tube. Mix 60 ml of sanitizer with 12 l of water in a plastic or stainless steel container to make a sanitizing solution.

Sanitizer	Water
60 ml (2 oz)	12 L (3 gal)

Step 11 Remove all parts as described in “Component Removal” on page 43.

Step 12 Take all components to sink and with 10 liters (2.5 gal) sanitizer/water mixture, sanitize all components with a soft nylon brush. Do not rinse the components.

Step 13 Use a nylon brush to sanitize the inside of the ice bin. Scrub the inside of the door, door track, bin, water sump, water distribution assembly and evaporator moldings. Do not rinse.

Step 14 Replace the sump drain overflow tube and transfer remaining 2 liters of solution into the sump trough. Replace all other components.

Step 15 To start a sanitizing cycle, press the toggle switch to the WASH position and hold for 5 seconds.

Step 16 Wait until the cycle is complete (approximately 13.5 minutes). Remove the water curtain, ice chute and overflow tube from the water sump. Allow all water to drain from the sump. Replace the disassembled parts. Press the toggle switch to the WASH position and hold for 5 seconds to start a rinse cycle. After the rinse cycle is complete (approximately 12 minutes), remove the water sump overflow tube, drain the water from the sump and replace the tube.

Step 17 Replace all the removed parts, then turn on the water supply switch.

Step 18 Place the toggle switch in the ON position, and the ice machine will start a new ice making cycle.

NOTE: To terminate a clean cycle, press the toggle switch in the WASH position and hold for more than 30 seconds.

 **Caution**

If the cleaner/sanitizer solution has been poured into the water trough, then the entire clean cycle must be completed. Don't terminate the cleaning cycle, or the ice machine will not purge the remaining cleaner/sanitizer solution from the water trough.

Component Removal

TOP COVER

For easiest access to the evaporator compartment, the top cover can be removed.

1. Remove two screws on the rear of the ice machine.
2. Slide top cover back to disengage the three pins from the front panel.

Remove the two screws and slide the top cover backwards to remove.

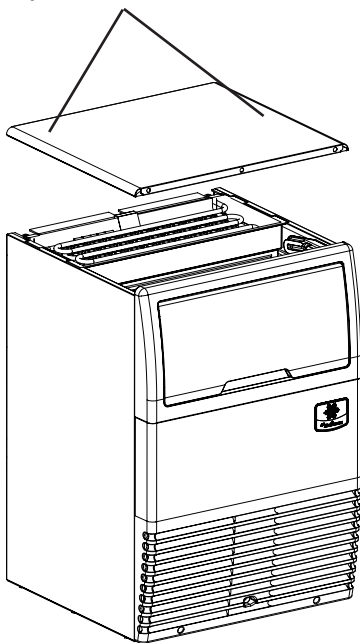

WATER CURTAIN

The water curtain is designed to keep the spraying water from escaping the evaporator compartment. Removal of the bin door is not required, but enhances access.

Grasp one end of the water curtain and lift up.

To re-install the water curtain, into ice machine, pivot the water curtain and pull it down into position. Make sure tabs are secure in grooves.

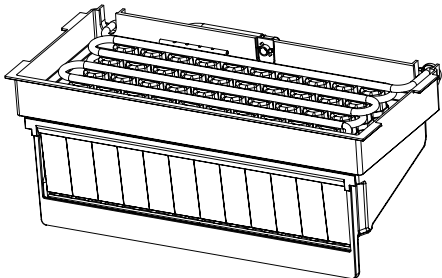

WATER SHUTTERS

WATER CURTAIN

The water curtain is designed to keep the spraying water from escaping the evaporator compartment. Removal of the bin door is not required, but enhances access.

Grasp one end of the water curtain and lift up.

To re-install the water curtain, into ice machine, pivot the water curtain and pull it down into position. Make sure tabs are secure in grooves.

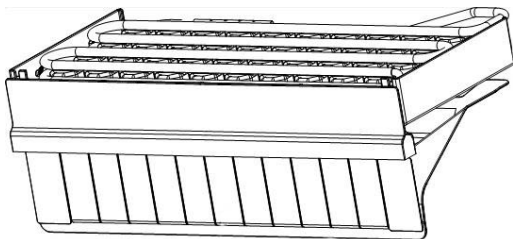

Water Curtain

ICE CHUTE

The ice chute is positioned over the spray nozzles and allows the ice to easily fall into the bin. It must be firmly positioned over the Spray Bar Assembly with the front edge inside the water trough or the spray nozzles will not be aligned with the spray holes, and spray water will fall into bin.

1. Grab protruding spray holes on one end and lift up.
2. Pivot ice chute and remove.
3. To re-install the ice chute, grasp protruding spray holes and position over the spray bar. Make sure the rear supports are over Spray Bar Assembly, and front edge is inside the water trough.

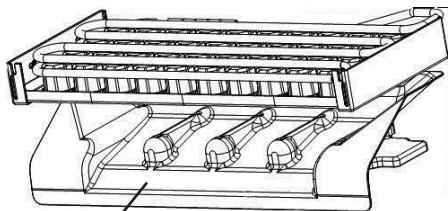

Ice Chute

SPRAY BAR

The spray bar supplies water to the individual ice-making cups. Water from the Water Pump sprays through the nozzles, located on the upper portion of the tubes.

1. Grasp one end of the spray bar, lift it up and remove from the seat formed in the water trough.
2. Remove both plastic clips on water inlet tubing by grasping both ears on clip and separating.
3. Apply a food grade lubricant to ease re-assembly of spray bar components when necessary.
4. To re-install spray bar, position the water inlet tubing on the inlet ports of the spray bar, and squeeze the clips until tight.
5. Reposition the assembly on the water trough seat.

Nozzles and inserts can be removed for cleaning by unscrewing nozzles. Inserts are located inside the spray bar ports. The entire spray pipe can be disassembled for cleaning.

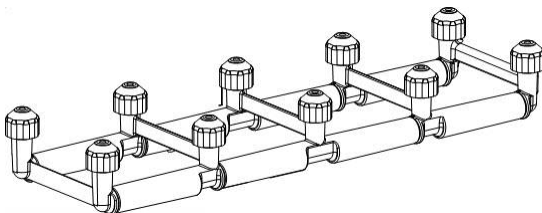

SUMP DRAIN OVERFLOW TUBE

The sump drain overflow tube is located in the evaporator water sump:

1. Remove the water curtain and ice chute.
2. Lift spray bar or disconnect and remove for easiest access.
3. Pull up on the overflow tube to remove.
4. To replace plug, insert in hole, and push with force to make a tight seal.

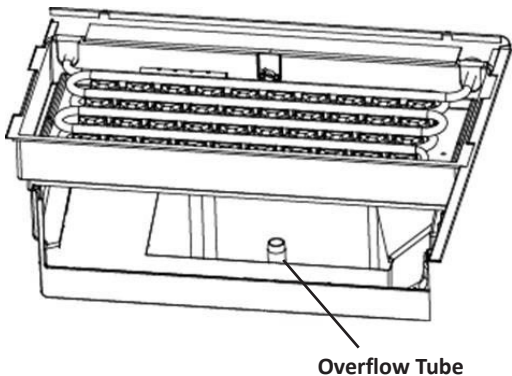

Cleaning the Condenser

Warning

Disconnect electric power to the ice machine before performing maintenance on equipment.

AIR-COOLED CONDENSER

A dirty condenser restricts airflow, resulting in excessively high operating temperatures. This reduces ice production and shortens component life.

Clean the condenser at least every six months.

1. Remove plastic front grill by removing two Phillips head screws. Clean grill openings before replacing.
2. Clean the outside of the condenser with a soft brush or a vacuum with a brush attachment. Clean from top to bottom, not side to side. Be careful not to bend the condenser fins.
3. Shine a flashlight through the condenser to check for dirt between the fins. If dirt remains:
 - A. Blow compressed air through the condenser fins. Be careful not to bend the fan blades.
 - B. If dirt or grease remains between fins, consult your local service representative.

Warning

The condenser fins are sharp. Use care when cleaning them.

Removal from Service/Winterization

General

Special precautions must be taken if the ice machine is to be removed from service for an extended period of time or exposed to ambient temperatures of 32 °F (0 °C) or below.

 **Caution**

If water is allowed to remain in the ice machine in freezing temperatures, severe damage to some components could result. Damage of this nature is not covered by the warranty.

Follow the applicable procedure below.

AIR-COOLED ICE MACHINES

1. Press the on/off switch to turn off the ice machine.
2. Disconnect the water supply.
3. Drain the water from the water sump and water pump by disconnecting the water pump tubing.
4. Disconnect and drain the incoming ice-making water line.
5. Blow compressed air in the water inlet and drain pipes of the ice machine until no water flows out.
6. Disconnect the electric power at the circuit breaker or air switch.
7. Make sure water is not trapped in any of the water inlet, drain lines, or distributed pipes.

Troubleshooting

Questions to Ask The Customer

An ice machine may manifest problems only at certain times of a day, but operate normally otherwise. Asking the user for some information can be helpful for assessment or even crucial in the final diagnosis.

Ask these questions before service:

- When does the malfunction occur? (Evening, day, all day or just during the freeze cycle)
- When is ice production low? (A certain day in a week, every day, or weekend)
- Describe the ice machine's status in detail.
- Has anyone ever operated the ice machine?
- Did the air switch, water supply, or ambient temperature change when the ice machine was in downtime?
- What has caused the water pressure to increase or decrease significantly?

Ice Machine Will Not Run

Nothing on the ice machine will operate (compressor, water pump, condenser fan motor). If any component runs this procedure can be skipped, move on to the next diagnostic (water pump won't run, compressor won't run, etc).

1. Place the toggle switch in the "WASH" position. If the water pump runs, begin with toggle switch diagnostics. If the water pump does not run, place the toggle switch in the "ice" position.
2. Verify correct voltage is present and matches the nameplate voltage.
3. The bin thermostat must be closed before any components can be energized.

COMPRESSOR WON'T RUN

If the water pump is running and the compressor is not, it may be tripping on overload or tripping the breaker/fuse. Check for grounded winding if the breaker keeps tripping.

1. Is the control board compressor relay LED energized?
2. Are the compressor windings closed?
3. Refer to "Compressor Electrical Diagnostics" on page 53.

Compressor Electrical Diagnostics

The compressor does not start or will trip repeatedly on overload.

CHECK RESISTANCE (OHM) VALUES

NOTE: Compressor windings can have very low ohm values. Use a properly calibrated meter.

Perform the resistance test after the compressor cools. The compressor dome should be cool enough to touch (49°C/120°F or below) to ensure that the overload is closed and the resistance readings will be accurate.

SINGLE PHASE COMPRESSORS

1. Disconnect power from the ice machine and remove the wires from the compressor terminals.
2. The measured resistance values between C and S and between C and R, when added together, should equal the resistance value between S and R.
3. If the overload is open, there will be a resistance reading between S and R, and open readings between C and S and between C and R. Allow the compressor to cool, then check the readings again.

CHECK MOTOR WINDINGS TO GROUND

Check continuity between all three terminals and the compressor shell or copper refrigeration line. Scrape metal surface to get good contact. If continuity is present, the compressor windings are grounded and the compressor should be replaced.

To determine if the compressor is seized: check the amp draw while the compressor is trying to start.

COMPRESSOR DRAWING HIGH AMPS

The continuous amperage draw on start-up should not be near the maximum fuse size indicated on the serial tag.

The wiring must be correctly sized to minimize voltage drop at compressor start-up. The voltage when the compressor is trying to start must be within $\pm 6\%$ of the nameplate voltage.

COMPRESSOR DRAWING LOCKED ROTOR

The three likely causes of this are:

- Low voltage supply (check voltage while compressor is trying to start),
- Defective starting component,
- Mechanically seized compressor.

To determine which you have:

- Install high and low side gauges,
- Try to start the compressor,
- Watch the pressures closely.

If the pressures do not move, the compressor is seized. Replace the compressor. If the pressures move, the compressor is turning slowly and is not seized. Check the capacitors and relay.

Diagnosing Start Components

If the compressor attempts to start, or hums and trips the overload protector, check the start components before replacing the compressor.

CAPACITOR

Visual evidence of capacitor failure can include a bulged terminal end or a ruptured membrane. Do not assume a capacitor is good if no visual evidence is present. A good test is to install a known good substitute capacitor. Use a capacitor tester when checking a suspect capacitor.

CURRENT RELAY

The relay has a set of contacts that energize and de-energize the compressor start winding. The contacts on the relay are normally open (start winding de-energized). When power is applied the run winding will be at LRA (Locked rotor Amperage). The relay coil becomes an electromagnet and closes the contacts (start winding energized). As the compressor motor RPM increases, the run winding current draw and relay coil magnetism decrease allowing the contacts to open. Replace a suspect relay with a known good relay, or use a momentary switch and start capacitor to mimic relay operation.

WATER PUMP WON'T RUN

Is the water pump winding closed?

1. Yes - Repair or replace the pump.
2. No - Is the water pump relay LED on the control board lit?
 - Yes: Repair or replace the motor.
 - No: Repair or replace the control board.

Hot Gas Valve Won't Energize

Is there line voltage at the hot gas valve?

1. Yes - Repair or replace the hot gas valve coil.
2. No - Is the hot gas valve relay LED on the control board lit?
 - Yes: Repair or replace the hot gas valve coil.
 - No: Repair or replace the control board.

Water Inlet Valve Won't Energize

Is there line voltage at the water inlet valve?

1. Yes - Repair or replace the water inlet valve coil.
2. No - Is the water inlet valve LED on the control board lit?
 - Yes: Repair or replace the water inlet valve.
 - No: Repair or replace the control board.

Ice Machine Prematurely Harvests

1. Is there line voltage at the hot gas valve?
 - No - Replace the hot gas valve.
2. Has the dip switch been adjusted?
 - Yes - Refer to “Ice Cube Thickness Check” and increase the cube size (increase the ice freeze time).
3. Refer to “Thermistor Diagnostics” and test the Water Thermistor and the Liquid Line Thermistor.

Ice Machine Will Not Harvest

1. Is the Liquid Line Thermistor temperature set too low?
2. Is the Liquid Line Thermistor sensor installed correctly?
3. Refer to the “Thermistor Diagnostics” to test the Liquid Line Thermistor.
4. Is there line voltage at the hot gas valve and water inlet solenoid?

Water System Checklist

A water-related problem often causes the same symptoms as a refrigeration system component malfunction.

Water system problems must be identified and eliminated prior to replacing refrigeration components.

WATER AREA (EVAPORATOR) IS DIRTY

- Clean as needed

WATER INLET PRESSURE IS NOT BETWEEN 1.4 AND 5.5 BAR (20-80PSI)

- Install a water regulator valve

INCOMING WATER TEMPERATURE IS NOT BETWEEN 1.7 °C AND 32.2 °C (35°- 90°F)

- Hot water does not enter the ice machine

WATER FILTRATION IS PLUGGED (IF USED)

- Replace the filter element or install a new water filtration system

HOSES, FITTINGS, ETC., ARE LEAKING WATER

- Repair or replace leaking parts

WATER INLET VALVE IS STUCK OPEN OR CLOSED

- Clean/replace as needed

WATER IS SPRAYING OUT OF THE SUMP TROUGH AREA

- Stop the water spray

UNEVEN WATER FLOW ACROSS THE EVAPORATOR

- Clean the ice machine

Ice Production Check

The amount of ice a machine produces directly relates to the operating water and air temperatures. This means an ice machine with a 21 °C (70°F) ambient temperature and 10°C (50°F) supply water produces more ice than the same model ice machine with a 32 °C (90°F) ambient temperature 21 °C (70°F) supply water.

1. Determine the ice machine operating conditions:
 - Air temperature entering condenser:
 - Ambient temperature:
 - Water temperature entering sump trough:
2. Refer to the appropriate 24-Hour Ice Production Chart.
3. Use the operating conditions determined in Step 1 to find the published (nominal) 24 hr. ice production:
 - Times are in minutes.

Example: 1 min. 15 sec. converts to 1.25 min.
(15 seconds ÷ 60 seconds = 0.25 minutes)

- Weights are in grams.

4. Perform an ice production check using the formula below.

1.	Freeze Time	+	Harvest Time	=	Total Cycle Time
2.	1440 = Minutes in 24 Hrs.	÷	Total Cycle Time	=	Cycles per Day
3.	Weight of One Harvest	×	Cycles per Day	=	Actual 24-Hour Production

Weighing the ice is the only 100% accurate check.

5. Compare the results of Step 3 with Step 2. Ice production is normal when these numbers are within 10% of each other. If they match closely, determine if:
- Another ice machine is required.
 - Relocating the existing equipment to lower the load conditions is required.

Analyzing Discharge Pressure

1. Determine the ice machine operating conditions:
 - Air temperature entering condenser:
 - Ambient temperature:
 - Water temperature entering sump trough:
2. Refer to the Cycle Times/24 Hour Ice Production/ Refrigeration Pressure Chart for the ice machine being checked.
3. Use the operating conditions determined in Step 1 to find the published (normal) discharge pressures:
 - Freeze Cycle:
 - Harvest Cycle:
4. Perform an actual discharge pressure check:

	Freeze Cycle PSIG	Harvesting Cycle PSIG
Beginning of Cycle		
End of Cycle		

Compare the actual discharge pressure (Step 3) with the published (nominal) discharge pressure (Step 2).

The discharge pressure is normal when the actual pressure falls within the published (nominal) pressure range for the ice machine's operating conditions. It is normal for the discharge pressure to be higher at the beginning of the freeze cycle (when load is greatest), then drop throughout the freeze cycle.

Discharge Pressure High Checklist

Improper Installation

- Refer to “Installation” section

Restricted Condenser Air Flow

- High inlet air temperature
- Condenser discharge air re-circulation
- Dirty condenser fins
- Defective fan motor

Improper Refrigerant Charge

- Overcharged
- Non-condensable in system
- Wrong type of refrigerant

Other

- High side refrigerant lines/component restricted (before mid-condenser)

Freeze Cycle Discharge Pressure Low Checklist

Improper Installation

- Refer to “Installation” section

Improper Refrigerant Charge

- Undercharged
- Wrong type of refrigerant

Other

- High side refrigerant lines/component restricted (before mid-condenser)

NOTE: Do not limit your diagnosis to only the items listed in the checklists.

Suction Pressure High Checklist

Improper Installation

- Refer to “Installation” section

Discharge Pressure

- A high discharge pressure will affect the suction pressure. Refer to “Discharge Pressure High Checklist”

Improper Refrigerant Charge

- Overcharged
- Non-condensable in system
- Wrong type of refrigerant

Other

- Hot gas valve leaking
- TXV flooding (check bulb mounting)
- Defective compressor

Suction Pressure Low Checklist

Improper Installation

- Refer to “Installation” section

Discharge Pressure

- A high discharge pressure will affect the suction pressure. Refer to “Discharge Pressure High Checklist”

Improper Refrigerant Charge

- Undercharged
- Wrong type of refrigerant

Other

- Improper water supply over evaporator. Refer to “Water System Checklist”
- Loss of heat transfer from tubing on back side of evaporator
- Restricted/plugged liquid line drier
- Restricted/plugged tubing or capillary tube in suction side of refrigeration system
- TXV starving
- Moisture in refrigeration system

NOTE: Do not limit your diagnosis to only the items listed in the checklists.

Discharge Line Temperature Analysis

General

The temperature of the compressor discharge line on a normally operating ice machine steadily increases throughout the freeze cycle. Comparing the temperatures over several cycles will result in a consistent maximum discharge line temperature.

Ambient air temperatures affect the maximum discharge line temperature.

Higher ambient air temperatures at the condenser = higher discharge line temperatures at the compressor

Lower ambient air temperatures at the condenser = lower discharge line temperatures at the compressor

Regardless of ambient temperature, the freeze cycle discharge line temperature will be higher than 71 °C (155°F) on a normally operating ice machine.

Procedure

Connect a temperature probe on the compressor discharge line.

Observe the discharge line temperature and record the maximum reading.

DISCHARGE LINE TEMPERATURE ABOVE 71 °C AT END OF FREEZE CYCLE:

Ice machines that are operating normally will have consistent maximum discharge line temperatures above 71 °C (155°F).

DISCHARGE LINE TEMPERATURE BELOW 71 °C (155°F) AT END OF FREEZE CYCLE:

Ice machines that have a flooding expansion valve will have a maximum discharge line temperature that decreases each cycle.

Verify the expansion valve sensing bulb is 100% insulated and sealed airtight. Condenser air contacting an incorrectly insulated sensing bulb will cause overfeeding of the expansion valve.

Verify the expansion valve sensing bulb is positioned and secured correctly.

Component Check Procedures

Electrical Components

ON/OFF/WASH TOGGLE SWITCH

Function

The switch is used to place the ice machine in ON, OFF or WASH mode of operation.

Specifications

Double-pole, double-throw switch.

Check Procedure

1. Inspect the toggle switch for correct wiring.
2. Isolate the toggle switch by disconnecting all wires from the switch.
3. Check across the toggle switch terminals using a calibrated ohmmeter. Note where the wire numbers are connected to the switch terminals, or refer to the wiring diagram to take proper readings.

Switch Setting	Terminals	Ohm Reading
ON	5-6	Open
	5-4	Closed
	2-1	Closed
	2-3	Open
WASH	5-4	Open
	5-6	Closed
	2-3	Closed
	2-1	Open
OFF	2-3	Open
	2-1	Open
	5-6	Open
	5-4	Open

Replace the toggle switch if ohm readings do not match all three-switch settings.

BIN THERMISTOR (T3)

Function

The bin thermistor stops the ice machine when the bin is full. When ice cubes contact the bin thermistor bulb holder, the bin thermistor opens and stops the ice machine. When ice cubes no longer contact the bin thermistor bulb holder, the bin thermistor closes and the ice machine starts.

The bin thermistor “temperature setting” is determined by the point of T2 (liquid line thermistor) at the time when T1 (sump water thermistor) comes below 2 °C. Refer to the Specifications Charts below for clearance.

Specifications

UG18/UG20/UG30

T1 (°C)	T2 (°C)	Shut down (T3)	Power on (T3)
≤2.0	T2≤32	≤1.7	≥2.2
≤2.0	32 <T2≤51	≤2.2	≥3.7
≤2.0	51 <T2	≤3.0	≥4.5

UG40/UG50/UG65

T1 (°C)	T2 (°C)	Shut down (T3)	Power on (T3)
≤2.0	T2≤28	≤1.5	≥2.0
≤2.0	28 <T2≤56	≤2.0	≥3.5
≤2.0	56 <T2	≤3.0	≥4.5

UG80

T1 (°C)	T2 (°C)	Shut down (T3)	Power on (T3)
≤2.0	T2≤37	≤1.5	≥2.0
≤2.0	37 <T2≤56	≤2.0	≥3.5
≤2.0	56 <T2	≤3.0	≥4.5

Check Procedure

Warning

Disconnect electrical power to the entire ice machine before proceeding.

Make sure bulb is inserted correctly 35.5 cm (14") in the bulb well. Disconnect the wires from the bin thermostat and check the resistance across the terminals.

No Ice on Bulb	Ice on Bulb	Result
Closed (O)	Open (OL)	Thermostat is good
Open (OL)	Closed (O)	Replace thermostat

NOTE: After covering/uncovering the bulb holder with ice, wait at least 3 minutes to allow the thermostat to react (Open/Close).

SUMP WATER THERMISTOR (T1) & LIQUID LINE THERMISTOR (T2)

Function

The sump water thermistor sensor is immersed in water to detect the sump temperature. The value supplied to the control board is used to initiate a freeze cycle.

The liquid line thermistor senses the refrigeration system liquid line temperature. This is used in conjunction with the control board to determine the length of the freeze and harvest cycles.

Specifications

The sump water thermistor:

$R_{2.0\text{ }^{\circ}\text{C}} \pm 0.5\text{ }^{\circ}\text{C} = 14.75\text{ K-ohm} \pm 1\%$

The liquid line thermistor:

$R_{25\text{ }^{\circ}\text{C}} \pm 0.5\text{ }^{\circ}\text{C} = 10\text{ K-ohm} \pm 1\%$

Check Procedure

1. Make sure the thermistor sensors are installed correctly.
2. Disconnect the thermistor from the control board and measure its resistance values.
3. Measure the temperature at the thermistor.
4. Compare the measured resistance/temperature.

Measured resistance/temperature is within 10% of the published resistance value—the thermistor is good.

T1 & T3 TEMPERATURE/RESISTANCE CHART

Important

If the ohmmeter reads "OL," check the scale setting on the meter before assuming the thermistor is bad.

Temperature	Resistance	Temperature	Resistance
°C	K Ohms (×1000)	°C	K Ohms (×1000)
-50	344.6	26	4.771
-49	320.5	27	4.567
-48	298.2	28	4.375
-47	277.6	29	4.190
-46	258.7	30	4.016
-45	241.1	31	3.849
-44	224.8	32	3.690
-43	209.8	33	3.538
-42	195.9	34	3.394
-41	183.0	35	3.256
-40	171.0	36	3.124
-39	159.9	37	2.999
-38	149.5	38	2.879
-37	140.0	39	2.764
-36	131.1	40	2.656
-35	122.8	41	2.551
-34	115.1	42	2.452
-33	108.0	43	2.356
-32	101.2	44	2.266
-31	95.03	45	2.179
-30	89.24	46	2.095
-29	83.83	47	2.016
-28	78.79	48	1.940
-27	74.09	49	1.867

Temperature	Resistance	Temperature	Resistance
°C	K Ohms (×1000)	°C	K Ohms (×1000)
-25	65.58	51	1.731
-26	69.70	50	1.797
-24	61.75	52	1.667
-23	58.16	53	1.606
-22	54.81	54	1.547
-21	51.66	55	1.491
-20	48.72	56	1.437
-19	45.97	57	1.385
-18	43.39	58	1.336
-17	40.96	59	1.289
-16	38.69	60	1.243
-15	36.56	61	1.200
-14	34.56	62	1.158
-13	32.68	63	1.117
-12	30.92	64	1.079
-11	29.25	65	1.041
-10	27.70	66	1.006
-9	26.24	67	0.9715
-8	24.85	68	0.9386
-7	23.55	69	0.9069
-6	22.33	70	0.8766
-5	21.18	71	0.8173
-4	20.09	72	0.8192
-3	19.07	73	0.7922
-2	18.10	74	0.7662
-1	17.19	75	0.7411
0	16.33	76	0.7170
1	15.52	77	0.6939

Temperature	Resistance	Temperature	Resistance
°C	K Ohms (×1000)	°C	K Ohms (×1000)
2	14.75	78	0.6715
3	14.02	79	0.6501
4	13.33	80	0.6293
5	12.69	81	0.6094
6	12.07	82	0.5902
7	11.49	83	0.5717
8	10.94	84	0.5538
9	10.43	85	0.5367
10	9.932	86	0.5201
11	9.466	87	0.5041
12	9.025	88	0.4887
13	8.608	89	0.4739
14	8.211	90	0.4595
15	7.836	91	0.4457
16	7.480	92	0.4323
17	7.142	93	0.4194
18	6.821	94	0.4069
19	6.516	95	0.3950
20	6.228	96	0.3833
21	5.953	97	0.3722
22	5.692	98	0.3613
23	5.444	99	0.3508
24	5.208	100	0.3407
25	4.984		

T2 TEMPERATURE/RESISTANCE CHART

Important

If the ohmmeter reads "OL," check the scale setting on the meter before assuming the thermistor is bad.

Temperature	Resistance	Temperature	Resistance
°C	K Ohms (×1000)	°C	K Ohms (×1000)
-40	225.1	36	6.623
-39	212.8	37	6.387
-38	200.6	38	6.162
-37	189.3	39	5.945
-36	178.7	40	5.738
-35	168.8	41	5.538
-34	159.4	42	5.347
-33	150.6	43	5.163
-32	142.4	44	4.987
-31	134.7	45	4.817
-30	127.5	46	4.655
-29	120.6	47	4.498
-28	114.2	48	4.348
-27	108.2	49	4.203
-26	102.5	50	4.064
-25	97.20	51	3.931
-24	92.17	52	3.803
-23	87.44	53	3.680
-22	82.97	54	3.561
-21	78.77	55	3.446
-20	74.80	56	3.336
-19	71.05	57	3.230
-18	67.52	58	3.127

Temperature	Resistance	Temperature	Resistance
°C	K Ohms (×1000)	°C	K Ohms (×1000)
-17	64.19	59	3.028
-16	61.03	60	2.933
-15	58.06	61	2.841
-14	55.24	62	2.753
-13	52.58	63	2.667
-12	50.07	64	2.585
-11	47.68	65	2.505
-10	45.43	66	2.428
-9	43.30	67	2.354
-8	41.27	68	2.283
-7	39.36	69	2.214
-6	37.55	70	2.147
-5	35.83	71	2.082
-4	34.19	72	2.020
-3	32.65	73	1.960
-2	31.18	74	1.902
-1	29.78	75	1.846
0	28.49	76	1.791
1	27.20	77	1.739
2	26.01	78	1.688
3	24.88	79	1.639
4	23.80	80	1.592
5	22.78	81	1.546
6	21.81	82	1.502
7	20.88	83	1.459
8	20.00	84	1.417
9	19.16	85	1.377
10	18.36	86	1.338

Temperature	Resistance	Temperature	Resistance
°C	K Ohms (×1000)	°C	K Ohms (×1000)
11	17.60	87	1.300
12	16.88	88	1.264
13	16.19	89	1.229
14	15.53	90	1.195
15	14.90	91	1.162
16	14.30	92	1.129
17	13.73	93	1.098
18	13.19	94	1.068
19	12.67	95	1.039
20	12.17	96	1.011
21	11.70	97	0.9838
22	11.24	98	0.9572
23	10.81	99	0.9316
24	10.40	100	0.9066
25	10.00	101	0.8832
26	9.622	102	0.8604
27	9.260	103	0.8384
28	8.913	104	0.8170
29	8.582	105	0.7964
30	8.265	106	0.7762
31	7.961	107	0.7564
32	7.670	108	0.7374
33	7.391	109	0.7190
34	7.124	110	0.7010
35	6.868		

HOT GAS VALVE

General

The hot gas valve is an electrically operated valve that opens when energized, and closes when de-energized.

NORMAL OPERATION

The valve is de-energized (closed) during the freeze cycle and energized (open) during the harvest cycle. The valve is positioned between the compressor and the evaporator and performs two functions:

1. Prevents refrigerant from entering the evaporator during the freeze cycle.

The hot gas valve is de-energized (closed) preventing refrigerant flow from the receiver into the evaporator.

2. Allows refrigerant vapor to enter the evaporator in the harvest cycle.

During the harvest cycle, the hot gas valve is energized (open) allowing refrigerant gas from the discharge line of the compressor to flow into the evaporator. The heat is absorbed by the evaporator and allows release of the ice slab.

Exact pressures vary according to ambient temperature and ice machine model. Harvest pressures can be found in the “Ice Production Pressure Chart” in this manual.

Hot Gas Valve Analysis

The valve can fail in two positions:

- Valve will not open in the harvest cycle.
- Valve remains open during the freeze cycle.

VALVE WILL NOT OPEN IN THE HARVEST CYCLE:

Although the control board has initiated the harvest cycle, the evaporator temperature remains unchanged from the freeze cycle.

VALVE REMAINS OPEN IN THE FREEZE CYCLE:

Symptoms of a hot gas valve remaining partially open during the freeze cycle can be similar to symptoms of an expansion valve, capillary tube or compressor problem. Symptoms are dependent on the amount of leakage in the freeze cycle.

A small amount of leakage will cause increased freeze times and the ice formation pattern on the top of the evaporator will be too thin, but a complete ice cube will eventually form.

Refer to the Parts Manual for proper valve application. If replacement is necessary, use only “original” Welbilt replacement solenoid valves.

Use the following procedure to help determine if a harvest valve is remaining partially open during the freeze cycle:

1. Wait 5 minutes into the freeze cycle.
2. Feel the inlet of the hot gas valve.

Important

Feeling the hot gas valve outlet or across the hot gas valve itself will not work for this comparison. The hot gas valve outlet is on the suction side (cool refrigerant). It may be cool enough to touch even if the valve is leaking.

3. Feel the compressor discharge line.

4. Compare the temperature of the inlet of the hot gas valve to the temperature of the compressor discharge line.

Findings	Comments
The inlet of the hot gas valve is cool enough to touch and the compressor discharge line is hot.	This is normal as the discharge line should always be too hot to touch and the harvest valve inlet, although too hot to touch during harvest, should be cool enough to touch after 5 minutes into the freeze cycle.
The inlet of the hot gas valve is hot and approaches the temperature of a hot compressor discharge line.	This is an indication something is wrong, as the harvest valve inlet did not cool down during the freeze cycle. If the compressor dome is also entirely hot, the problem is not a harvest valve leaking, but rather something causing the compressor (and the entire ice machine) to get hot.
Both the inlet of the hot gas valve and the compressor discharge line are cool enough to touch.	This is an indication that something is wrong, causing the compressor discharge line to be cool to the touch. This is not caused by a harvest valve leaking.

PAGE INTENTIONALLY LEFT BLANK

Flammable Refrigerant Procedures

Servicing Requirements

- It is recommended that only technicians specifically trained in handling flammable refrigerants, service or dispose of equipment containing hydrocarbon refrigerants.
- Color-coded red process tubes indicate use of a flammable refrigerant - Process tubes must be replaced after brazing or other service procedures.
- An accessible fire extinguisher is required when brazing.
- A combustible gas leak detector with a minimum sensitivity of 8 grams per cubic meter is required. The meter must be on while servicing the equipment. Place the detector on the floor and set the detector to beep at approximately heart beat rate.
- Equipment using hydrocarbon refrigerants have fittings unique to flammable refrigerants.
- Work in well-ventilated, open spaces - A ventilation fan can be used to disperse any residual refrigerant. Place the fan a minimum of 10' (3m) away from the work area.
- Eliminate all ignition sources.
- The filter drier must be replaced whenever the system is opened to the atmosphere.

Important

- Remove piercing valves after charging.
- Unit is critically charged. Nitrogen must be purged through the system while brazing to prevent build up of copper oxide in the refrigeration system.
- Manifold gauge set must be removed properly to ensure that no refrigerant contamination or loss occurs. A quick disconnect is required for the high side connection.

REFRIGERANT PURGING REQUIREMENTS

NOTE: Country and Local Codes for removal and processing of this refrigerant must always take precedence over these procedures.

- Minimum of 10 feet from building, verify wind direction will not introduce refrigerant into building
- Verify refrigerant does not enter buildings through intake air vents
- Although not required hydrocarbon refrigerants can be recovered, instead of venting to the atmosphere.
- Purge system with dry nitrogen to displace any trapped propane.

DANGER

Disconnect all electric power to the system. Shorting electrical wires to refrigeration tubing may result in an explosion.

REFRIGERANT PURGING PROCEDURE

1. Disconnect all electric power to the system and lockout tag out the power source(s).

NOTE: Some systems may have more than one power supply.

2. Work in well-ventilated, open space and eliminate all ignition sources.
3. Install piercing valves on the high and low side access fittings.
4. Attach manifold gauge set to the low and high side fittings. Hoses need to be as short as practical, due to the small refrigerant charge.
5. Purge refrigerant from both low and high side.
6. Purge the system with dry nitrogen for 3 minutes.
7. Evacuate the system with a vacuum pump
8. Purge the system again with dry nitrogen
9. Open the system by cutting the tubes with a tube cutter. Do not use a torch to open the system.

BRAZING PROCEDURE

10. Always purge nitrogen whenever using a torch. The nitrogen pressure regulator must be equipped with two gauges; One gauge to measure the cylinder pressure, and one to measure the discharge (refrigeration system psig). The pressure regulator must be capable of reducing the pressure to 2 or 3 psig (14 - 20 kPa) and steadily maintaining this pressure.

PRESSURE TESTING

11. Pressure test with dry nitrogen to detect leaks. Use nitrogen and a trace amount of refrigerant to locate the leak if a pressure test indicates a leak is present.
12. Do not over pressurize the system. Check the name plate for the maximum test pressure.

DANGER

Failure to properly purge or pressure test a system for leaks, can result in serious injury or death from explosion, fire, or contact with refrigerant or lubricant mists.

EVACUATION

13. Slowly release the nitrogen and evacuate to a minimum of 500 microns.

NOTE: Do not start the compressor while it is in a vacuum or energize the compressor with the terminal cover off. Always break a vacuum with refrigerant before energizing (starting) the compressor.

Refrigerant Charging

Due to the small refrigerant quantities, a cap tube in the .50 to .85 ID range with a shutoff valve at the access port can be used to control the flow of refrigerant. The charge accuracy must be within +/- 1% of the nameplate listed charge.

14. Invert the charging bottle, and place on a scale capable of reading grams and ounces.
15. Purge liquid refrigerant to the shutoff valve, then zero out the scale and allow the reading to settle.

NOTE: It is important that the scales and hoses are positioned so that they will not be disturbed when adding refrigerant.

Important

The charge is critical on all Manitowoc ice machines. Use a scale to ensure the proper charge is installed. A quick disconnect is required for the high side connection

16. Add refrigerant through the high side and close the valve just before the nameplate refrigerant amount is reached, then add refrigerant to reach the final charge amount. If all of the refrigerant can not be added to the high side, the remainder can be added as vapor to the low side while the compressor is running.
17. Press the power button.

NOTE: Manifold gauge set must be removed properly to ensure no refrigerant contamination or loss occurs.

18. Verify all of the vapor in the charging hoses is drawn into the refrigeration system before disconnecting the charging hoses.
 - A. Run the ice machine in freeze cycle.
 - B. Remove the high side low loss fitting.
 - C. Open the high and low side valves on the manifold gauge set. Any refrigerant in the lines will be pulled into the low side of the system.
 - D. Allow the suction pressures in the refrigeration system and the manifold gauge set to equalize while the ice machine is in the freeze cycle.
 - E. Isolate and remove the low side hose.
19. Use a pinch-off tool on the access fitting and remove temporary access valves and seal the refrigeration system.

System Contamination Cleanup

This section describes the basic requirements for restoring contaminated systems to reliable service.

DETERMINING SEVERITY OF CONTAMINATION

System contamination is generally caused by either moisture or residue from compressor burnout entering the refrigeration system.

Inspection of the refrigerant usually provides the first indication of system contamination. Obvious moisture or an acrid odor in the refrigerant indicates contamination.

If either condition is found, or if contamination is suspected use a test kit.

If a refrigerant test kit indicates harmful levels of contamination, or if a test kit is not available, inspect the compressor oil.

1. Remove the refrigerant charge from the ice machine.
2. Remove the compressor from the system.
3. Check the odor and appearance of the oil.
4. Inspect open suction and discharge lines at the compressor for burnout deposits.
5. If no signs of contamination are present, perform an acid oil test to determine the type of cleanup required.

Contamination/Cleanup Chart	
Symptoms/Findings	Required Cleanup Procedure
No symptoms or suspicion of contamination	Normal evacuation/recharging procedure
Moisture/Air Contamination symptoms Refrigeration system open to atmosphere for longer than 15 minutes Refrigeration test kit and/or acid oil test shows contamination No burnout deposits in open compressor lines	Mild contamination cleanup procedure
Mild Compressor Burnout symptoms Oil appears clean but smells acrid Refrigeration test kit or acid oil test shows harmful acid content No burnout deposits in open compressor lines	Mild contamination cleanup procedure
Severe Compressor Burnout symptoms Oil is discolored, acidic, and smells acrid Burnout deposits found in the compressor, lines, and other components	Severe contamination cleanup procedure

MILD SYSTEM CONTAMINATION CLEANUP PROCEDURE

1. Replace any failed components.
2. If the compressor is good, change the oil.
3. Replace the liquid line drier.

NOTE: If the contamination is from moisture, use heat lamps during evacuation. Position them at the compressor, condenser and evaporator prior to evacuation. Do not position heat lamps too close to plastic components, or they may melt or warp.

4. Follow the normal evacuation procedure, except replace the evacuation step with the following:
 - A. Pull vacuum to 1000 microns. Break the vacuum with dry nitrogen and sweep the system. Pressurize to a minimum of 5 psig.
 - B. Pull vacuum to 500 microns. Break the vacuum with dry nitrogen and sweep the system. Pressurize to a minimum of 5 psig.
 - C. Change the vacuum pump oil.
 - D. Pull vacuum to 500 microns. Run the vacuum pump for 1/2 hour on self-contained models, 1 hour on remotes.

NOTE: You may perform a pressure test as a preliminary leak check. You should use an electronic leak detector after system charging to be sure there are no leaks.

5. Charge the system with the proper refrigerant to the nameplate amount.
6. Operate the ice machine.

SEVERE SYSTEM CONTAMINATION CLEANUP PROCEDURE

1. Remove the refrigerant charge.
2. Remove the compressor.
3. If burnout deposits are found, replace the TXV.
4. Wipe away any burnout deposits from suction and discharge lines at compressor.
5. Sweep through the open system with dry nitrogen.
6. Install a new compressor and new start components.
7. Install suction line filter-drier in front of compressor.
8. Install a new liquid line drier.
9. Follow the normal evacuation procedure, except replace the evacuation step with the following:
 - A. Pull vacuum to 1000 microns. Break the vacuum with dry nitrogen and sweep the system. Pressurize to a minimum of 5 psig.
 - B. Change the vacuum pump oil.
 - C. Pull vacuum to 500 microns. Break the vacuum with dry nitrogen and sweep the system. Pressurize to a minimum of 5 psig.
 - D. Change the vacuum pump oil.
 - E. Pull vacuum to 500 microns. Run the vacuum pump for 1 additional hour.

10. Charge the system with the proper refrigerant to the nameplate charge.
11. Operate the ice machine for one hour. Then, check the pressure drop across the suction line filter-drier.
 - A. If the pressure drop is less than 2 psig, the filter-drier should be adequate for complete cleanup.
 - B. If the pressure drop exceeds 2 psig, change the suction line filter-drier and the liquid line drier. Repeat until the pressure drop is acceptable.
12. Operate the ice machine for 48 – 72 hours. Replace the suction line and liquid line drier if necessary.
13. Follow normal evacuation procedures.

PAGE INTENTIONALLY LEFT BLANK

Charts

Cycle Times/24-Hour Ice Production/ Refrigerant Pressure Charts

These charts are used as guidelines to verify correct ice machine operation.

Accurate collection of data is essential to obtain the correct diagnosis.

- Exclude all non-refrigeration issues before diagnosing the refrigeration system.
- Visually inspect the clearances, drains, condensers/ filters for dirt and replace the water filter.
- Verify that the water flow is uniform throughout the evaporator.
- Ice production checks that are within 10% of the chart are considered normal. This is due to variances in water and air temperature. Actual temperatures will seldom match the chart exactly.
- Refer to “Operational Analysis Chart” for the list of data that must be collected for refrigeration diagnostics.
- Zero out manifold gauge set before obtaining pressure readings to avoid mis-diagnosis.
- Discharge and suction pressure are highest at the beginning of the cycle. Suction pressure will drop throughout the cycle. Verify the pressures are within the range indicated.

UGP020 SELF-CONTAINED AIR-COOLED

NOTE: These characteristics may vary depending on operating conditions.

Total Cycle Time

Freeze Time + Harvest Time = Total Cycle Time

Ambient Temperature °F/°C	Freeze Time			Harvest Time
	Water Temperature °F/°C			
	50/10	70/21	90/32	
70/21	15.0-16.9			1.6 - 3.5
80/27				
90/32		21.0-23.6		
100/38				
110/43			31.2-34.9	

Times are in minutes.

24 Hour Ice Production

Ambient Temperature °F/°C	Inlet Water Temperature °F/°C		
	50/10	70/21	90/32
70/21	24		
80/27			
90/32		18	
100/38			
110/43			12.50

Based on the average ice weight of 288-230 grams. Individual cube weight 19 grams. Number of individual cubes per cycle: 16.

UGP020 OPERATING TEMPERATURES

Ambient Temperature °F/°C	Freeze Cycle			Harvest Cycle	
	Discharge Temperature °C	Suction Temperature °C	Harvest Valve Inlet Temperature °C	Discharge Temperature °C	Suction Temperature °C
50/10	37 - 57	-9 - 33	17 - 13	54 - 29	4 - 10
70/21	49 - 60	-7 - 32	24 - 21	54 - 38	7 - 18
80/27	60 - 66	-32 - 26	35 - 31	66 - 43	7 - 21
90/32	68 - 74	-32 - 23	41 - 35	66 - 49	7 - 10
110/43	85 - 92	-11 - 21	52 - 49	77 - 60	7 - 29

UGP030 SELF-CONTAINED AIR-COOLED

NOTE: These characteristics may vary depending on operating conditions.

Total Cycle Time

Freeze Time + Harvest Time = Total Cycle Time

Ambient Temperature °F/°C	Freeze Time			Harvest Time
	Water Temperature °F/°C			
	50/10	70/21	90/32	
70/21	16.3-18.3			1.6-3.5
80/27				
90/32		21.0-23.6		
100/38				
110/43			31.6-35.4	

Times are in minutes.

24 Hour Ice Production

Ambient Temperature °F/°C	Inlet Water Temperature °F/°C		
	50/10	70/21	90/32
70/21	34		
80/27			
90/32		27	
100/38			
110/43			18.5

Based on the average ice weight of 432-480 grams. Individual cube weight 19 grams. Number of individual cubes per cycle: 24.

UGP030 OPERATING TEMPERATURES

Ambient Temperature °F/°C	Freeze Cycle			Harvest Cycle	
	Discharge Temperature °C	Suction Temperature °C	Harvest Valve Inlet Temperature °C	Discharge Temperature °C	Suction Temperature °C
50/10	41 - 54	-1 - -21	24 - 23	54 - 41	10 - 27
70/21	52 - 68	-1 - 21	33 - 31	67 - 52	12 - 32
80/27	64 - 82	0 - 18	42 - 39	81 - 63	14 - 38
90/32	77 - 96	1 - 17	51 - 48	94 - 74	17 - 43
110/43	88 - 107	2 - 15	60 - 57	107 - 85	18 - 49

UGP040 SELF-CONTAINED AIR-COOLED

NOTE: These characteristics may vary depending on operating conditions.

Total Cycle Time

Freeze Time + Harvest Time = Total Cycle Time

Ambient Temperature °F/°C	Freeze Time			Harvest Time
	Water Temperature °F/°C			
	50/10	70/21	90/32	
70/21	18.6-20.8			1.6-3.5
80/27				
90/32		24.1-26.8		
100/38				
110/43			34.5-38.3	

Times are in minutes.

24 Hour Ice Production

Ambient Temperature °F/°C	Inlet Water Temperature °F/°C		
	50/10	70/21	90/32
70/21	53		
80/27			
90/32		42	
100/38			
110/43			30

Based on the average ice weight of 760-840 grams. Individual cube weight 20 ±1 grams. Number of individual cubes per cycle: 40.

UGP040 OPERATING TEMPERATURES

Ambient Temperature °F/°C	Freeze Cycle			Harvest Cycle	
	Discharge Temperature °C	Suction Temperature °C	Harvest Valve Inlet Temperature °C	Discharge Temperature °C	Suction Temperature °C
50/10	38 - 49	7 - 19	29 - 21	49 - 32	1 - 21
70/21	43 - 54	9 - 19	32 - 27	57 - 41	1 - 23
80/27	49 - 63	10 - 18	38 - 32	63 - 47	2 - 26
90/32	54 - 68	12 - 15	43 - 38	71 - 54	3 - 27
110/43	27 - 88	22 - 9	53 - 49	88 - 68	4 - 27

UGP080 SELF-CONTAINED AIR-COOLED

NOTE: These characteristics may vary depending on operating conditions.

Total Cycle Time

Freeze Time + Harvest Time = Total Cycle Time

Ambient Temperature °F/°C	Freeze Time			Harvest Time
	Water Temperature °F/°C			
	50/10	70/21	90/32	
70/21	18.0-20.1			1.6-3.5
80/27				
90/32		20.9-23.3		
100/38				
110/43			32.0-35.6	

Times are in minutes.

24 Hour Ice Production

Ambient Temperature °F/°C	Inlet Water Temperature °F/°C		
	50/10	70/21	90/32
70/21	76.5		
80/27			
90/32		67	
100/38			
110/43			45

Based on the average ice weight of 1064-1176 grams. Individual cube weight 20±1 grams. Number of individual cubes per cycle: 56.

UGP080 OPERATING TEMPERATURES

Ambient Temperature °F/°C	Freeze Cycle			Harvest Cycle	
	Discharge Temperature °C	Suction Temperature °C	Harvest Valve Inlet Temperature °C	Discharge Temperature °C	Suction Temperature °C
50/10	49 - 64	3 - 15	24 - 21	61 - 46	2 - 21
70/21	57 - 77	7 - 14	39 - 36	77 - 56	4 - 32
80/27	60 - 83	10 - 13	40 - 36	182 - 60	4 - 35
90/32	68 - 91	10 - 11	44 - 41	88 - 64	8 - 38
110/43	77 - 107	10 - 12	54 - 52	99 - 72	10 - 38

UGE0020A Self-Contained Air-Cooled

These characteristics may vary depending on operating conditions.

TOTAL CYCLE TIME

Freeze Time + Harvest Time = Total Cycle Time

Ambient Temperature °F/°C	Freeze Time			Harvest Time
	Water Temperature °F/°C			
	50/10	70/21	90/32	
50/10	15.4-18.0			1.4-3.5
70/21	15.7-18.2			
90/32		21.7-25.5		
100/38			26.9-33.2	
110/43			33.7-39.0	

Times are in minutes.

24 HOURLY ICE PRODUCTION

Ambient Temperature °F/°C	Water temperature ° F/°C		
	50/10	70/21	90/32
50/10	21.37		
70/21	21.57		
90/32		16.89	
100/38			14.06
110/43			11.32

Based on the average ice weight of 430-480 grams. Individual cube weight 19±1 grams. Number of individual cubes per cycle: 24.

OPERATING PRESSURES

Ambient Temperature °F/°C	Freeze Cycle		Harvest Cycle	
	Discharge Pressure bar	Suction Pressure bar	Discharge Pressure bar	Suction Pressure bar
50/10	5.1-4.5	0.7-0.2	4.4-7.6	1.5-4.1
70/21	6.8-6.3	0.8-0.2	5.0-8.0	1.5-4.2
90/32	9.9-9.0	0.9-0.3	5.2-9.5	2.4-5.1
110/43	15.1-12.9	1.1-0.4	7.6-12.2	3.1-6.7

Suction pressure drops gradually throughout the freeze cycle.

UGE0030A SELF-CONTAINED AIR-COOLED

These characteristics may vary depending on operating conditions.

TOTAL CYCLE TIME

Freeze Time + Harvest Time = Total Cycle Time

Ambient Temperature °F/°C	Freeze Time			Harvest Time ¹
	Water Temperature °F/°C			
	50/10	70/21	90/32	
50/10	16.4-19.8			1.4-3.5
70/21	17.5-19.0			
90/32		22.4-25.0		
100/38			26.4-35.2	
110/43			37.3-41.7	

1 Times are in minutes.

24 HOURLY ICE PRODUCTION

Ambient Temperature °F/°C	Water temperature ° F/°C		
	50/10	70/21	90/32
50/10	28.37		
70/21	30.96		
90/32		25.48	
100/38			20.66
110/43			16.11

Based on the average ice weight of 430-480 grams. Individual cube weight 19 ±1 grams. Number of individual cubes per cycle: 24.

OPERATING PRESSURES

Ambient Temperature °F/°C	Freeze Cycle		Harvest Cycle	
	Discharge Pressure bar	Suction Pressure bar	Discharge Pressure bar	Suction Pressure bar
50/10	4.2-3.2	0.50-0	7.0-8.9	1.2-4.2
70/21	8.0-6.6	0.54-0	7.5-9.3	1.6-4.4
90/32	11.4-8.9	0.6-0.4	7.8-11.5	2.0-5.4
110/43	15.5-13.2	1.5-0.7	10.4-12.6	3.2-6.1

Suction pressure drops gradually throughout the freeze cycle.

UGF0040A SELF-CONTAINED AIR-COOLED

These characteristics may vary depending on operating conditions.

TOTAL CYCLE TIME

Freeze Time + Harvest Time = Total Cycle Time

Ambient Temperature °F/°C	Freeze Time			Harvest Time
	Water Temperature °F/°C			
	50/10	70/21	90/32	
50/10	17.5-21.7			1.4-3.5
70/21	19.5-22.3			
90/32		24.4-28.9		
100/38			31.2-35.5	
110/43			37.0-44.9	

Times are in minutes.

24 HOURLY ICE PRODUCTION

Ambient Temperature °F/°C	Water temperature ° F/°C		
	50/10	70/21	90/32
50/10	43.52		
70/21	46.5		
90/32		39.28	
100/38			31.08
110/43			24.90

Based on the average ice weight of 720-800 grams. Individual cube weight 19 ±1 grams. Number of individual cubes per cycle: 40.

OPERATING PRESSURES

Ambient Temperature °F/°C	Freeze Cycle		Harvest Cycle	
	Discharge Pressure bar	Suction Pressure bar	Discharge Pressure bar	Suction Pressure bar
50/10	9.2-7.0	2.2-1.2	7.35-13.6	5.4-5.9
70/21	14.2-9.0	2.2-1.8	7.4-13.64	5.4-5.9
90/32	19.1-17.5	2.9-2.2	8.3-18.4	6.3-6.6
110/43	25.1-22.0	3.8-2.6	8.8-23.3	6.6-7.3

Suction pressure drops gradually throughout the freeze cycle.

UGF0050A SELF-CONTAINED AIR-COOLED

These characteristics may vary depending on operating conditions.

TOTAL CYCLE TIME

Freeze Time + Harvest Time = Total Cycle Time

Ambient Temperature °F/°C	Freeze Time			Harvest Time
	Water Temperature °F/°C			
	50/10	70/21	90/32	
50/10	13.9-14.9			1.4-3.5
70/21	17.4-18.1			
90/32		23.6-25.5		
100/38			31.5-33.3	
110/43			39.5-43.6	

Times are in minutes.

24 HOURLY ICE PRODUCTION

Ambient Temperature °F/°C	Water temperature ° F/°C		
	50/10	70/21	90/32
50/10	61.9		
70/21	56.1		
90/32		43.22	
100/38			34.6
110/43			23.4

Based on the average ice weight of 720-800 grams. Individual cube weight 19 ±1 grams. Number of individual cubes per cycle: 40.

OPERATING PRESSURES

Ambient Temperature °F/°C	Freeze Cycle		Harvest Cycle	
	Discharge Pressure bar	Suction Pressure bar	Discharge Pressure bar	Suction Pressure bar
50/10	12.0-10.6	3.5-1.4	7.2-8.2	4.8-6.3
70/21	15.6-12.7	3.9-1.4	8.6-10.1	6.3-7.9
90/32	20.2-19.4	4.8-1.7	11.5-12.7	7.6-10.1
110/43	25.5-23.0	4.8-1.7	12.3-14.2	9.0-11.6

Suction pressure drops gradually throughout the freeze cycle.

UGF0065A SELF-CONTAINED AIR-COOLED

These characteristics may vary depending on operating conditions.

TOTAL CYCLE TIME

Freeze Time + Harvest Time = Total Cycle Time

Ambient Temperature °F/°C	Freeze Time			Harvest Time
	Water Temperature °F/°C			
	50/10	70/21	90/32	
50/10	18.8-21.6			1.4-3.5
70/21	18.4-19.9			
90/32		23.0-24.9		
100/38			28.5-31.9	
110/43			35.4-37.8	

Times are in minutes.

24 HOURLY ICE PRODUCTION

Ambient Temperature °F/°C	Water temperature ° F/°C		
	50/10	70/21	90/32
50/10	62.1		
70/21	66.9		
90/32		59.1	
100/38			48.7
110/43			39.2

Based on the average ice weight of 1010-1120 grams. Individual cube weight 19 ±1 grams. Number of individual cubes per cycle: 56.

OPERATING PRESSURES

Ambient Temperature °F/°C	Freeze Cycle		Harvest Cycle	
	Discharge Pressure bar	Suction Pressure bar	Discharge Pressure bar	Suction Pressure bar
50/10	8.7-20.5		11.2-14.6	6.4-8.4
70/21	13.5-12.6	1.9-1.4	11.3-14.7	6.4-8.5
90/32	19.0-17.1	2.4-1.9	11.3-16.7	6.5-10.0
110/43	25.0-22.2	3.2-2.7	13.3-19.9	8.0-12.2

Suction pressure drops gradually throughout the freeze cycle.

UGF0080A SELF-CONTAINED AIR-COOLED

These characteristics may vary depending on operating conditions.

TOTAL CYCLE TIME

Freeze Time + Harvest Time = Total Cycle Time

Ambient Temperature °F/°C	Freeze Time			Harvest Time
	Water Temperature °F/°C			
	50/10	70/21	90/32	
50/10	13.0-13.1			1.4-3.5
70/21	13.8-16.4			
90/32		21.8-23.3		
100/38			25.4-28.5	
110/43			29.5-33.5	

Times are in minutes.

24 HOURLY ICE PRODUCTION

Ambient Temperature °F/°C	Water temperature ° F/°C		
	50/10	70/21	90/32
50/10	88.7		
70/21	85.8		
90/32		66.8	
100/38			55.6
110/43			44.9

Based on the average ice weight of 1010-1120 grams. Individual cube weight 19 ±1 grams. Number of individual cubes per cycle: 56.

OPERATING PRESSURES

Ambient Temperature °F/°C	Freeze Cycle		Harvest Cycle	
	Discharge Pressure bar	Suction Pressure bar	Discharge Pressure bar	Suction Pressure bar
50/10	13.4-28.1	4.8-3.5	12.6-13.9	8.7-10.4
70/21	16.6-13.9	4.9-3.5	12.7-13.9	8.7-10.5
90/32	21.0-17.9	5.4-3.7	12.8-14.0	8.8-10.5
110/43	25.8-24.3	25.2-4.2	14.3-15.8	9.9-11.7

Suction pressure drops gradually throughout the freeze cycle.

PAGE INTENTIONALLY LEFT BLANK

Wiring Diagrams

Wiring Diagrams

The following pages contain electrical wiring diagrams. Be sure you are referring to the correct diagram for the ice machine you are servicing.

Warning

Always disconnect power before working on electrical circuitry.

WIRING DIAGRAM LEGEND

The following symbols are used on all of the wiring diagrams:

- * Internal Compressor Overload
(Some models have external compressor overloads)
- ** Fan Motor Run Capacitor
(Some models do not incorporate fan motor run capacitor)
- () Wire Number Designation
(The number is marked at each end of the wire)
- >>— Multi-pin Connection
(Electrical Box Side) —>>—
(Compressor Compartment Side)

UGE0020A Air-Cooled

Number	Component
4	Bin Thermistor
5	Compressor
7	Compressor Overload
10	Compressor Relay
12	Compressor Start Capacitor
13	Compressor Start Relay
14	Condenser Fan Motor
19	Control Board
28	Fuse
40	Toggle Switch
42	Solenoid Valve - Harvest
49	Thermistor Liquid Line
54	Transformer Control Board
56	Water Inlet Valve
58	Water Pump
60	Water Trough Thermistor
61	Wiring Harness Connector
Wire Colors	
BLK	Black
BLU	Blue
BRN	Brown
GRY	Grey
ORG	Orange
PRPL	Purple
RED	Red
WHT	White
YEL	Yellow

UGP0020A AIR-COOLED

Self-Contained Air-Cooled

Diagram shown in freeze cycle

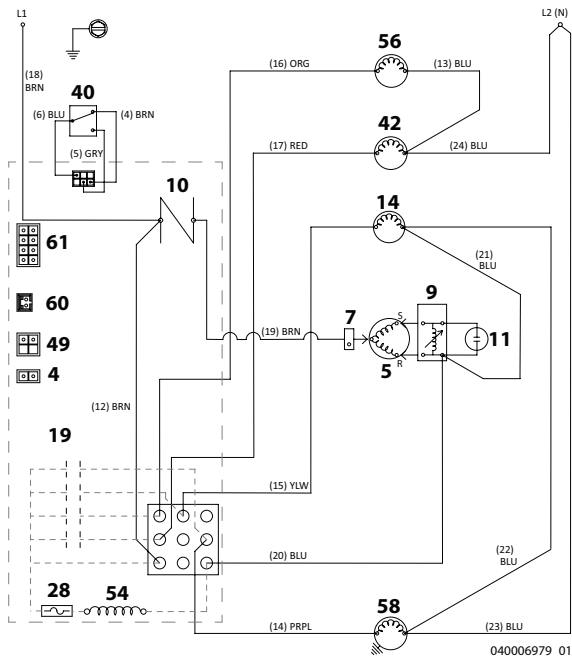

UGE0020A Air-Cooled

Number	Component
4	Bin Thermistor
5	Compressor
7	Compressor Overload
9	Compressor PTCR
10	Compressor relay
11	Compressor Run Capacitor
14	Condenser Fan Motor
19	Control Board
28	Fuse
40	Toggle Switch
42	Solenoid Valve - Harvest
49	Thermistor Liquid Line
54	Transformer Control Board
56	Water Inlet Valve
58	Water Pump
60	Water Trough Thermistor
61	Wiring Harness Connector
Wire Colors	
BLK	Black
BLU	Blue
BRN	Brown
GRY	Grey
ORG	Orange
PRPL	Purple
RED	Red
WHT	White
YEL	Yellow

UGE0030A/UGF0040A/UGF0050A/UGF0065A Air-Cooled

Number	Component
4	Bin Thermistor
5	Compressor
7	Compressor Overload
10	Compressor Relay
12	Compressor Start Capacitor
13	Compressor Start Relay
14	Condenser Fan Motor
19	Control Board
28	Fuse
40	Toggle Switch
42	Solenoid Valve - Harvest
49	Thermistor Liquid Line
54	Transformer Control Board
56	Water Inlet Valve
58	Water Pump
60	Water Trough Thermistor
61	Wiring Harness Connector
Wire Colors	
BLK	Black
BLU	Blue
BRN	Brown
GRY	Grey
ORG	Orange
PRPL	Purple
RED	Red
WHT	White
YEL	Yellow

UGP0030A/UGP0040A/UGP0050A AIR-COOLED

Self-Contained Air-Cooled

Diagram shown in freeze cycle

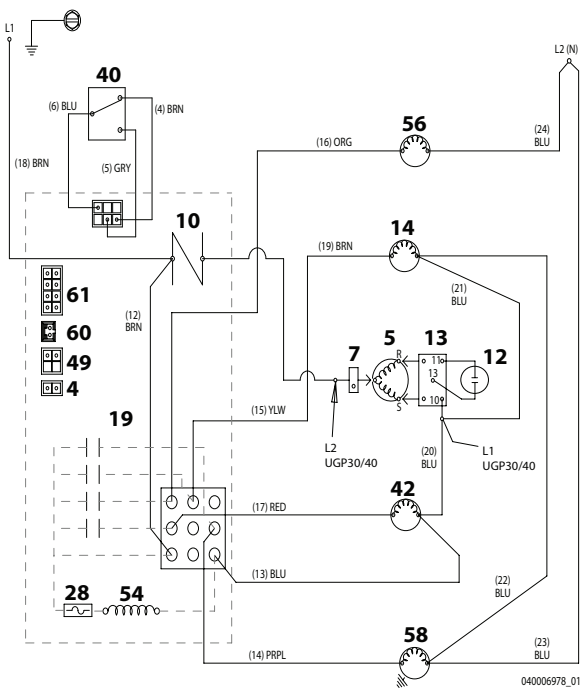

UGP0030A/UGP0040A/UGP0050A Air-Cooled

Number	Component
4	Bin Thermistor
5	Compressor
7	Compressor Overload
10	Compressor Relay
12	Compressor Start Capacitor
13	Compressor Start Relay
14	Condenser Fan Motor
19	Control Board
28	Fuse
40	Toggle Switch
42	Solenoid Valve - Harvest
49	Thermistor Liquid Line
54	Transformer Control Board
56	Water Inlet Valve
58	Water Pump
60	Water Trough Thermistor
61	Wiring Harness Connector
Wire Colors	
BLK	Black
BLU	Blue
BRN	Brown
GRY	Grey
ORG	Orange
PRPL	Purple
RED	Red
WHT	White
YEL	Yellow

UGF0080A AIR-COOLED

Self-Contained Air-Cooled

Diagram shown in freeze cycle

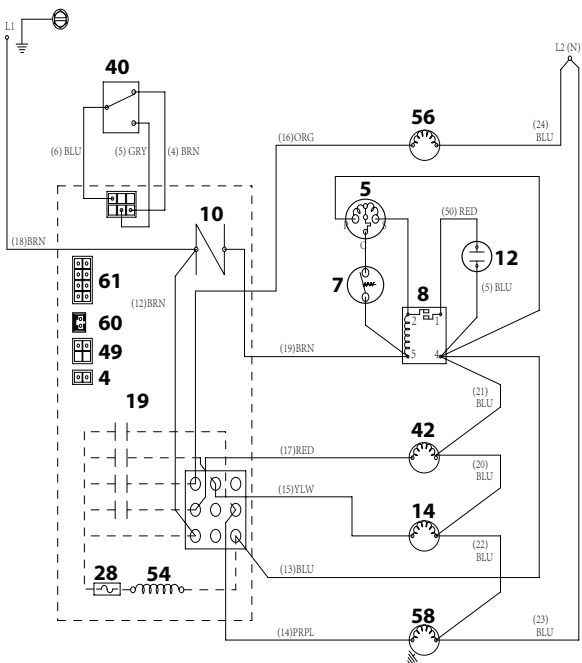

UGF0080A Air-Cooled

Number	Component
4	Bin Thermistor
5	Compressor
7	Compressor Overload (Internal on 230V 50hz or 60hz)
8	Compressor Potential Relay
10	Compressor Relay
12	Compressor Start Capacitor
14	Condenser Fan Motor
19	Control Board
28	Fuse
40	Toggle Switch
42	Solenoid Valve - Harvest
49	Thermistor Liquid Line
54	Transformer Control Board
56	Water Inlet Valve
58	Water Pump
60	Water Trough Thermistor
61	Wiring Harness Connector
Wire Colors	
BLK	Black
BLU	Blue
BRN	Brown
GRY	Grey
ORG	Orange
PRPL	Purple
RED	Red
WHT	White
YEL	Yellow

UGP0080A AIR-COOLED

Self-Contained Air-Cooled

Diagram shown in freeze cycle

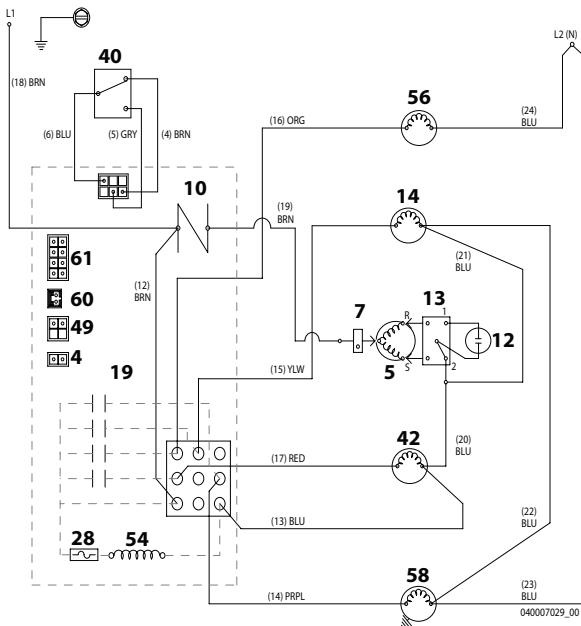

UGP0080A Air-Cooled

Number	Component
4	Bin Thermistor
5	Compressor
7	Compressor Overload
10	Compressor Relay
12	Compressor Start Capacitor
13	Compressor Start Relay
14	Condenser Fan Motor
19	Control Board
28	Fuse
40	Toggle Switch
42	Solenoid Valve - Harvest
49	Thermistor Liquid Line
54	Transformer Control Board
56	Water Inlet Valve
58	Water Pump
60	Water Trough Thermistor
61	Wiring Harness Connector
Wire Colors	
BLK	Black
BLU	Blue
BRN	Brown
GRY	Grey
ORG	Orange
PRPL	Purple
RED	Red
WHT	White
YEL	Yellow

Tubing Schematics

UG0020A

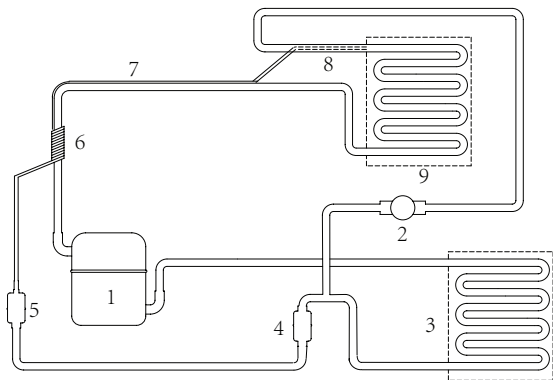

Number	Component
1	Compressor
2	Harvest Solenoid
3	Condenser
4	Receiver - Water-Cooled Only
5	Liquid Line Drier
6	Heat Exchanger
7	Heat Exchanger
8	Capillary Tube
9	Evaporator

UG0030A/UG0040A/UG0065A

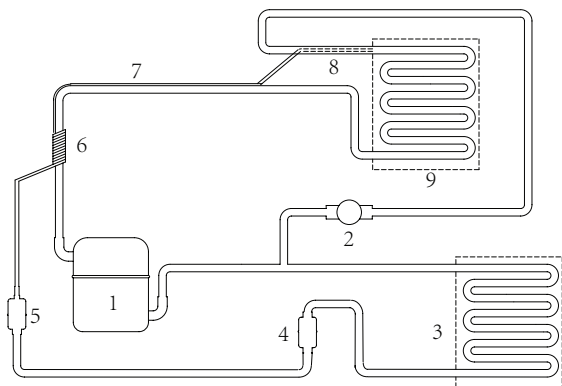

Number	Component
1	Compressor
2	Harvest Solenoid
3	Condenser - Air-Cooled or Water-Cooled
4	Receiver - Water-Cooled Only
5	Liquid Line Drier
6	Heat Exchanger
7	Heat Exchanger
8	Capillary Tube
9	Evaporator

UG0050A/UG0080A

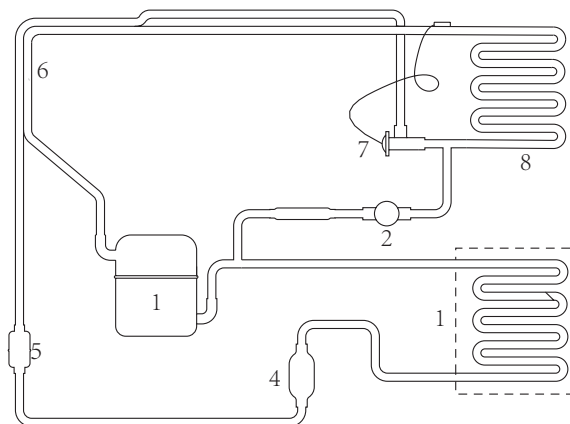

Number	Component
1	Compressor
2	Harvest Solenoid
3	Condenser - Air-Cooled or Water-Cooled
4	Receiver - Water-Cooled Only
5	Liquid Line Drier
6	Heat Exchanger
7	TXV - Expansion Valve
8	Evaporator



MANITOWOC ICE
2110 SOUTH 26TH STREET
MANITOWOC, WI 54220

844-724-2273
WWW.MANITOWOCICE.COM



Welbilt offers fully-integrated kitchen systems and our products are backed by KitchenCare® aftermarket parts and service. Welbilt's portfolio of award-winning brands includes Cleveland™, Convothorn®, Crem®, Delfield®, fitkitchen®, Frymaster®, Garland®, Kolpak®, Lincoln®, Manitowoc®, Merco®, Merryche® and Multiplex®.

Bringing innovation to the table • welbilt.com