

***S Model & Ice Beverage  
QuietQube®  
Ice Machines***

**Technician's  
Handbook**

This manual is updated as new information and models are released. Visit our website for the latest manual.  
[www.manitowocice.com](http://www.manitowocice.com)

***America's #1 Selling Ice Machine***

Part Number 8015053 06/18



## Safety Notices

As you work on Manitowoc equipment, be sure to pay close attention to the safety notices in this handbook. Disregarding the notices may lead to serious injury and/or damage to the equipment.

Throughout this handbook, you will see the following types of safety notices:



### **Warning**

Text in a Warning box alerts you to a potential personal injury situation. Be sure to read the Warning statement before proceeding, and work carefully.



### **Caution**

Text in a Caution box alerts you to a situation in which you could damage the equipment. Be sure to read the Caution statement before proceeding, and work carefully.

## Procedural Notices

As you work on Manitowoc equipment, be sure to read the procedural notices in this handbook. These notices supply helpful information which may assist as you work.

Throughout this handbook, you will see the following types of procedural notices:

### **Important**

Text in an Important box provides you with information that may help you perform a procedure more efficiently. Disregarding this information will not cause damage or injury, but it may slow you down as you work.

NOTE: Text set off as a Note provides you with simple, but useful, extra information about the procedure you are performing.

## Read These Before Proceeding:

### **Caution**

Proper installation, care and maintenance are essential for maximum performance and trouble-free operation of your Manitowoc equipment. If you encounter problems not covered by this handbook, do not proceed, contact Manitowoc Foodservice Group. We will be happy to provide assistance.

### **Important**

Routine adjustments and maintenance procedures outlined in this handbook are not covered by the warranty.

### **Warning**

#### **PERSONAL INJURY POTENTIAL**

Do not operate equipment that has been misused, abused, neglected, damaged, or altered/modified from that of original manufactured specifications. This appliance is not intended for use by persons (including children) with reduced physical, sensory or mental capabilities, or lack of experience and knowledge, unless they have been given supervision concerning use of the appliance by a person responsible for their safety. Do not allow children to play with, clean or maintain this appliance without proper supervision.

# Table of Contents

---

## General Information

Model Numbers . . . . .	13
How to Read a Model Number . . . . .	14
Ice Cube Sizes . . . . .	15
Model/Serial Number Location . . . . .	16
Energy Efficient Ice Machine	
Serial Breaks . . . . .	16

## Installation

Location of Ice Machine . . . . .	17
Ice Machine Head Section	
Clearance Requirements . . . . .	18
Stacking Two Ice Machines on a	
Single Storage Bin . . . . .	19
Ice Deflector . . . . .	19
Removing the Front Panels . . . . .	20
Location of CVD® Condensing Unit . . . . .	21
Condensing Unit Clearance	
Requirements . . . . .	22
Bin Installation . . . . .	23
S1470C/S1870C/S2070C/S2170C	
Installation on a Manitowoc Bin . . . . .	25
Ice Machine on a Dispenser Installation	27
Ice Machine Head Section Water	
Supply and Drains . . . . .	30
Electrical Requirements . . . . .	34
Refrigeration System Installation . . . . .	36
<b>Operational Checks . . . . .</b>	<b>56</b>
General . . . . .	56
Water Level . . . . .	56
Ice Thickness Check . . . . .	57
Harvest Sequence Water Purge . . . . .	58
<b>Electronic Bin Thermostat Instructions</b>	
<b>IB600C/IB680C/IB800C/IB1000C Only . . . . .</b>	<b>59</b>
Positioning . . . . .	59

## Component Identification

Ice Machine Head Sections . . . . .	61
CVD® Condensing Units . . . . .	65

## Maintenance

<b>General</b> . . . . .	67
<b>Cleaning / Sanitizing Procedure</b> . . . . .	68
Cleaning Procedure . . . . .	68
Parts Removal for Cleaning/Sanitizing	70
Sanitizing Procedure . . . . .	77
<b>Procedure to Clean Heavily Scaled</b>	
<b>Ice Machines</b> . . . . .	79
General . . . . .	79
Cleaning Procedure . . . . .	79
Parts Removal for Cleaning/Sanitizing	82
Sanitizing Procedure . . . . .	96
Additional Component Removal . . . . .	98
<b>Removal from Service/Winterization</b> . . .	102
General . . . . .	102
CVD1486 Water Cooled Condensing Unit . . . . .	103

## Sequence of Operation

Initial Start-Up or Start-Up After	
Automatic Shut-Off . . . . .	105
Freeze Sequence . . . . .	107
Harvest Sequence . . . . .	108
Automatic Shut-Off . . . . .	111

<b>Troubleshooting</b>	
<b>Safety Limits</b>	117
Safety Limit Analysis	119
Safety Limit#1	120
Safety Limit #2	121
Safety Limit #3	122
<b>Control Board Testing</b>	123
Control Board Test Cycle	123
<b>Troubleshooting By Symptom</b>	124
<b>Symptom #1 Ice Machine Will Not Run</b>	125
Diagnosing an Ice Machine Head Section that Will Not Run	127
Diagnosing a Condensing Unit That Will Not Run	128
Compressor Electrical Diagnostics	129
<b>Symptom #2 Low Production, Long Freeze     Cycle</b>	132
Symptom #2 - Refrigeration System Opera- tional Analysis Tables	134
Symptom #2 - Freeze Cycle Refrigeration System Operational Analysis Table Proce- dures	143
<b>Symptom #3 Ice Will Not Harvest</b>	160
Ice Machine will Not Harvest Diagnostics	160
Harvest Problems	161
<b>Symptom #3 Ice Will Not Harvest, Cubes Are     Not Melted Flowchart</b>	162
<b>Symptom #4 Ice Will not Harvest - Cubes Are     Melted Flowchart</b>	166

## Component Check Procedures

<b>Electrical Components</b> . . . . .	169
Main Fuse . . . . .	169
Bin Switch . . . . .	170
Harvest Assist Air Pump . . . . .	173
ICE/OFF/CLEAN Toggle Switch . . . . .	174
Ice Thickness Probe (Harvest Initiation) . . . . .	176
Water Level Control Circuitry . . . . .	181
Electronic Bin Thermostat Control . . .	187
Compressor Electrical Diagnostics . . .	192
Diagnosing Start Components . . . . .	194
<b>Refrigeration Components</b> . . . . .	197
Refrigerant Charge Verification . . . . .	197
Suction Accumulator Operation . . . . .	199
Headmaster Control Valve . . . . .	200
Headmaster Valve Water-Cooled Condens- ing Unit - CVD1476 . . . . .	205
Water Regulating Valve CVD1476 . . .	207
Fan Cycle Control . . . . .	208
High Pressure Cutout (HPCO) Control	209
Low Pressure Cutout (LPCO) Control	210
<b>Refrigerant Recovery/Evacuation</b> . . . . .	211
Connections . . . . .	212
Recovery/Evacuation Procedures . . .	214
Charging Procedures . . . . .	215
<b>System Contamination Cleanup</b> . . . . .	216
Determining Severity of Contamination	216
Cleanup Procedure . . . . .	218
<b>Refrigerant Reuse Policy</b> . . . . .	223

## Component Specifications

Main Fuse . . . . .	225
Bin Switch . . . . .	225
Harvest Assist Air Pump . . . . .	225
ICE/OFF/CLEAN Toggle Switch . . . . .	225
Electronic Bin Thermostat Control . . . . .	225
Water Regulating Valve . . . . .	225
Fan Cycle Control . . . . .	226
High Pressure Cutout (HPCO) Control . . . . .	226
Low Pressure Cutout (LPCO) Control . . . . .	226
Filter-Driers . . . . .	227
Total System Refrigerant Charge . . . . .	229

## Charts

<b>Cycle Times/24-Hour Ice Production/Refrigerant Pressure . . . . .</b>	<b>231</b>
S0600C/CVD0675 Series Remote Air Cooled . . . . .	232
SD0682C/CVD0685 Series Remote Air Cooled . . . . .	233
SY0684C/CVD0685 Series Remote Air Cooled . . . . .	234
IB0600C/CVD675 Series Remote Air Cooled . . . . .	235
IB0682DC/CVD685 Series Remote Air Cooled . . . . .	236
IB0684YC/CVD685 Series Remote Air Cooled . . . . .	237
SD0872C/SY0874C/CVD0885 Series Remote Air Cooled Machines Before Serial Number 110682385 . . . . .	238
SD0872C/CVD0885 Series Remote Air Cooled Machines After Serial Number 110682385 . . . . .	239
SY0874C/CVD0885 Series Remote Air Cooled Machines After Serial Number 110682385 . . . . .	240

IB0822DC/IB0824YC/CVD885 Series Remote Air Cooled Machines Before Serial Number 110682385 .....	241
IB0822DC/CVD885 Series Remote Air Cooled Machines After Serial Number 110682385 .....	242
IB0824YC/CVD885 Series Remote Air Cooled Machines After Serial Number 110682385 .....	243
SD1072C/SY1074C/CVD1085 Series Remote Air Cooled Machines Before Serial Number 110697654 .....	244
SD1072C/CVD1085 Series Remote Air Cooled Machines After Serial Number 110697654 .....	245
SY1074C/CVD1085 Series Remote Air Cooled Machines After Serial Number 110697654 .....	246
IB1022DC/IB1024YC/CVD1075/CVD1085/CVD1285 Series Remote Air Cooled Machines Before Serial Number 110697294 .....	247
IB1022DC/CVD1185 Series Remote Air Cooled Machines After Serial Number 110697294 .....	248
IB1024YC/CVD1185 Series Remote Air Cooled Machines After Serial Number 110697294 .....	249
SD1272C/SY1274C/CVD1285 Series Remote Air Cooled Machines Before Serial Number 110706336 .....	250

SD1272C/CVD1285 Series Remote Air Cooled Machines After Serial Number 110706336 .....	251
SY1274C/CVD1285 Series Remote Air Cooled Machines After Serial Number 110706336 .....	252
S1470C/CVD1485 Series Remote Air Cooled .....	253
S1470C/CVD1486 Remote Water Cooled	254
SD1872C/CVD1885 Series Remote Air Cooled .....	255
SY1874C/CVD1885 Series Remote Air Cooled .....	256
SD2072C/CVD2075 Series Remote Air Cooled .....	257
SY2074C/CVD2075 Series Remote Air Cooled .....	258
SD2172C/CVD2085 Series Remote Air Cooled .....	259
SY2174C/CVD2085 Series Remote Air Cooled .....	260
SDF3000C/CVDF3000 Series Remote Air Cooled .....	261
SYF3000C/CVDF3000 Series Remote Air Cooled .....	262
SD3072C/CVD3085 Series Remote Air Cooled .....	263
SY3074C/CVD3085 Series Remote Air Cooled .....	264

## Diagrams

<b>Wiring Diagrams</b> .....	265
Wiring Diagram Legend .....	265
S600C/S850C/1000C/S1200C .....	266
S600C/S680C/S850C/1000C/S1200C	267
S1470C/S1870C/S2070C/S2170C ..	268
SF3000C/S3070C 115/60/1 .....	269
SF3000C/S3070C 230V/50Hz/1Ph ..	270

IB0600C/IB0800C/IB1000C with S Control Board and Electronic Bin Thermostat . . . . .	271
IB0600C/IB0680C/IB0800C/IB1000C with Air Assist/ S Control Board and Elec- tronic Bin Thermostat . . . . .	272
CVD675/CVD685/CVD885/CVD1075/ CVD1085/CVD1185/CVD1285/CVD1485/ CVD1486/CVD1885/CVD2075/CVD3085/ CVDF3000 - 1 Phase . . . . .	273
CVD2085 without PTCR- 1 Phase . . .	274
CVD2085 with PTCR- 1 Phase . . . . .	275
CVD675/CVD685/CVD885/CVD1075/ CVD1085/CVD1185/CVD1285/CVD1485/ CVD1486/CVD1885/CVD2075/CVD2085/ CVD3085/CVDF3000 - 3 Phase . . . . .	276
CVD3085/CVDF3000 380V/50hz/3ph	277
<b>Electronic Control Board . . . . .</b>	<b>278</b>
Single and Twin Evaporator Models . .	278
Quad Evaporator Models . . . . .	280
<b>Refrigeration Tubing Schematics . . . . .</b>	<b>281</b>
S600C/S680C/S850C/S1000C/S1200C . . . . .	281
S600C/S680C/S850C/S1000C/S1200C . . . . .	282
Ice Beverage IB0600C/IB0680C/IB0800C/ IB1000C . . . . .	283
Ice Beverage IB0600C/IB0680C/IB0800C/ IB1000C . . . . .	284
S1470C/S1870C/S2070C/S2170C . . .	285
S1470C/S1870C/S2070C/S2170C . . .	286
S1476C Water-Cooled Condenser . . .	287
S3070C Without Check Valve . . . . .	288
SF3000C/S3070C With Check Valve .	289

## General Information

### MODEL NUMBERS

This manual covers the following models:

Ice Machine Head Section	CVD Condensing Unit*
SD0672C SY0674C IB0624YC IB0622DC	CVD0675
SD0682C SY0684C IB0684YC IB0682DC	CVD0685
SD0872C SY0874C IB0824YC IB0822DC	CVD0885
SD1072C SY1074C	CVD1085
IB1024YC IB1022DC	CVD1185 CVD1285 CVD1085 CVD1075
SD1272C SY1274C	CVD1285
SD1472C SY1474C	CVD1485 CVD1486
SD1872C SY1874C	CVD1885
SD2072C SY2074C	CVD2075
SD2172C SY2174C	CVD2085
SD3072C SY3074C	CVD3085
SDF3000C SYF3000C	CVDF3000
*For 3 phase electrical option: add the number "3" to end of model number (CVD10853).	

# HOW TO READ A MODEL NUMBER

## Head Section

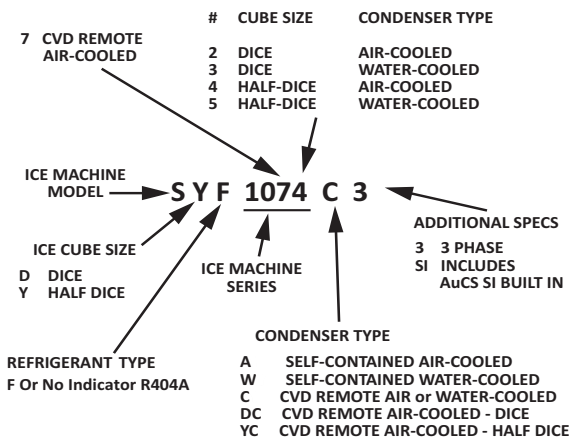

## Condensing Unit

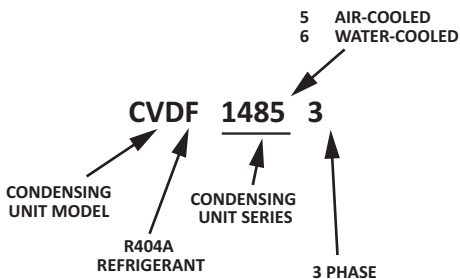

## ICE CUBE SIZES

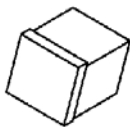

Dice

7/8" x 7/8" x 7/8"  
2.22 x 2.22 x 2.22 cm

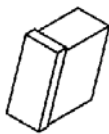

Half Dice

3/8" x 1-1/8" x 7/8"  
0.95 x 2.86 x 2.22 cm

### **Warning**

Do not operate equipment that has been misused, abused, neglected, damaged, or altered/modified from that of original manufactured specifications.

This appliance is not intended for use by persons (including children) with reduced physical, sensory or mental capabilities, or lack of experience and knowledge, unless they have been given supervision concerning use of the appliance by a person responsible for their safety.

### **Warning**

All Manitowoc ice machines require the ice storage system (bin, dispenser, etc.) to incorporate an ice deflector.

Prior to using a non-Manitowoc ice storage system with other Manitowoc ice machines, contact the manufacturer to assure their ice deflector is compatible with Manitowoc ice machines.

## MODEL/SERIAL NUMBER LOCATION

These numbers are required when requesting information from your local Manitowoc Distributor, service representative, or Manitowoc Ice, Inc. The model and serial number are listed on the OWNER WARRANTY REGISTRATION CARD. They are also listed on the MODEL/SERIAL NUMBER DECAL affixed to the ice machine.

## ENERGY EFFICIENT ICE MACHINE SERIAL BREAKS

Some specifications have changed since our release of Energy Efficient machines. The following machines have a serial break to indicate when they became Energy Efficient.

<b>Series Ice Machine</b>	<b>Serial Break for Energy Efficient Machines</b>
S850C	110682385
S1000C	110697654
S1200C	110706336
IB800C	110682385
IB1000C	110697294
CVD885	110673885

NOTE: SF3000C & CVDF3000 have been assigned new model numbers for the energy efficient versions.

# Installation

---

## LOCATION OF ICE MACHINE

### **S600C/S680C/S850C/S1000C/S1200C/S1470C/ S1870C/S2070C/S2170C/S3070C/SF3000C**

The location selected for the ice machine head section must meet the following criteria. If any of these criteria are not met, select another location.

- The location must be free of airborne and other contaminants.
- The air temperature must be at least 35°F (1.7°C), but must not exceed 110°F (43.4°C).
- The location must not be near heat-generating equipment, in direct sunlight and be protected from weather.
- The location must not obstruct airflow through or around the ice machine. Refer to ice machine head section clearance requirements.

### **IB0600C/IB0680C/IB0800C/IB1000C**

- Ice/Beverage Ice Machines require the installation of a thermostat to maintain dispenser ice level. The thermostat ships with the ice machine.
- The ice machine head is installed with the electrical inlet, water supply inlet, refrigeration tubing and water drain entering from the back of the ice machine.
- The ice machine head section contains a service loop that must remain installed between the ice machine head section and line set. Sufficient tubing length must be available to allow 180° rotation of the ice machine.
- Maintain a 3" space between the back of the ice machine and the back of the dispenser to allow room for the refrigeration line set service loop.
- The water inlet and electrical connection must contain a service loop to allow future service and maintenance access.
- The drain line must contain a union or other suitable means of disconnection at the ice machine head section.

- The location must be free of airborne and other contaminants.
- The air temperature must be at least 35°F (1.6°C), but must not exceed 110°F (43.4°C).
- The location must not be near heat-generating equipment or in direct sunlight.
- The location must not obstruct airflow through or around the ice machine. Refer to ice machine head section clearance requirements.

## **ICE MACHINE HEAD SECTION CLEARANCE REQUIREMENTS**

### **S600C/S680C/S850C/S1000C/S1200C/S1470C/ S1870C/S2070C/S2170C**

**Top** 5" (12.7 cm) is recommended for efficient operation and removal of top cover/servicing.

**Sides** 5" (12.7 cm) is recommended for efficient operation and servicing. There is no minimum clearance required.

**Back** 3" (7.6 cm) required when routing electrical inlet, water inlet and refrigeration tubing out of the top of the unit.

5" (12.7 cm) required when routing all connections out the back.

### **IB0600C/IB0680C/IB0680C/IB0800C/IB1000C**

**Top** 2" (5.1 cm) required clearance for cleaning procedures and servicing.

**Back** 5" (12.7 cm) required when routing all connections out the back.

**Sides** 8" (20.3 cm) required for servicing.

### **S3070C/SF3000C**

**Top/Sides** 8" (20.3 cm) recommended clearance for efficient operation and removal of top cover/servicing. There is no minimum clearance required.

**Back** 24" (61.0 cm) required when routing all connections out the back.

**NOTE: 24" (61.0 cm) on all sides is recommended to allow access without moving the machine.**

 **Caution**

The ice machine head section must be protected if it will be subjected to temperatures below 32°F (0°C). Failure caused by exposure to freezing temperatures is not covered by the warranty. See “Removal from Service/Winterization” page 102.

**STACKING TWO ICE MACHINES ON A SINGLE STORAGE BIN**

S QuietQube ice machines cannot be stacked. However an adapter is available that allows two S QuietQube ice machines to be placed side by side on 60” Manitowoc F & B style bins.

**ICE DEFLECTOR**

An ice deflector is required for all ice machines installed on a bin.

 **Warning**

S1470C/S1870C/S2170C ice machines are not approved for use on Manitowoc B570 bins.

 **Warning**

30” large capacity B model bins must be attached to the wall with the bracket provided with the bin.

## REMOVING THE FRONT PANELS

1. Disconnect power to ice machine.
2. Loosen screws. Do not remove they are retained by o-rings to prevent loss.
3. To remove right front door lift up and remove.

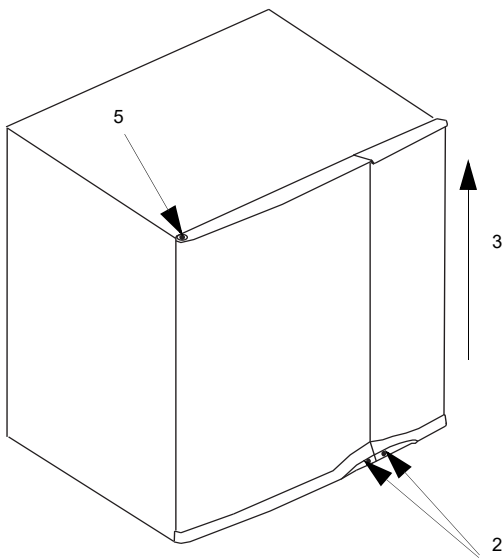

### Door Removal

4. Open left front door to 45 degrees.
5. Support with left hand, depress top pin, tilt top of door forward and lift out of bottom pin to remove.

## LOCATION OF CVD® CONDENSING UNIT

The location selected for the CVD Condensing Unit must meet the following criteria. If any of these criteria are not met, select another location.

- *CVD885/CVD1075/CVD1085/CVD1485/CVD1885/CVD2085 Only* - The air temperature must be at least -20°F (-28.9°C) but must not exceed 130°F (54.4°C).
- *CVD675/CVD685/CVD1185/CVD2075/CVD3085/SF3000C Only* - The air temperature must be at least -20°F (-28.9°C) but must not exceed 120°F (48.9°C).
- *CVD1486 Only*- The air temperature must be at least 50°F (10°C) but must not exceed 110°F (43°C).
- The location must not allow exhaust fan heat and/or grease to enter the condenser.
- The location must not obstruct airflow through or around the condensing unit. See below for clearance requirements.

## **CONDENSING UNIT CLEARANCE REQUIREMENTS**

### **CVD675/CVD685/CVD885/CVD1075/CVD1085/ CVD1185/ CVD2075/CVD2085**

**Top/Sides** - There is no minimum clearance required, although 6" (15.2 cm) is recommended for efficient operation and servicing only.

**Front/Back** - 48" (122 cm)

### **CVD1285/CVD1485/CVD1885**

**Top/Sides** - There is no minimum clearance required, although 6" (15.2 cm) is recommended for efficient operation and servicing only.

**Front** - 24" (61 cm)

**Back** - 48" (122 cm)

### **CVD1486 ONLY**

**Top** - 5" (12.7 cm) is required for efficient operation and servicing.

**Front/Back/Sides** - 12" (30.5 cm)

### **CVD3085/CVDF3000**

**Top/Sides** - There is no minimum clearance required, although 8" (20.3 cm) is recommended for efficient operation and servicing only.

**Front/Back** - 24" (122 cm)

***NOTE: 24" (61.0 cm) on all sides is recommended to allow easy access.***

## **BIN INSTALLATION**

All ice machines installed on a bin require an ice deflector. Manitowoc bins have a built in deflector that requires no modifications when used with a forward facing evaporator. Ice machines with multiple evaporators require a deflector kit.

Bin adapters or custom bin tops are available to allow installation of a 30" ice machine on a 48" or 60" bin. Refer to ice machine price list for options (<http://www.manitowocice.com/sales/price.asp>).



### **Warning**

Manitowoc QuietQube ice machines require the ice storage bin to incorporate an ice deflector.

Prior to using a non-Manitowoc ice storage system with other Manitowoc ice machines, contact the manufacturer to assure their ice deflector is compatible with Manitowoc ice machines.

## Leveling the Ice Storage Bin

1. Screw the leveling legs onto the bottom of the bin.
2. Screw the foot of each leg in as far as possible.

### **Caution**

The legs must be screwed in tightly to prevent them from bending.

3. Move the bin into its final position.
4. Level the bin to assure that the bin door closes and seals properly. Use a level on top of the bin. Turn each foot as necessary to level the bin.

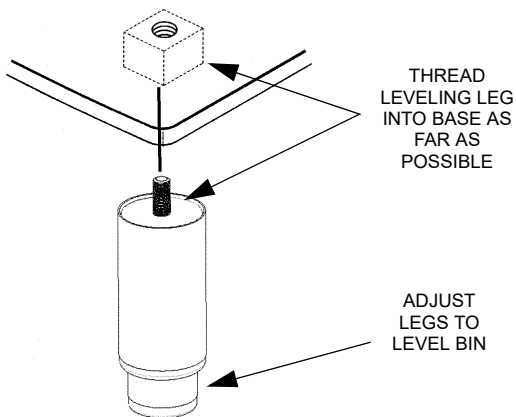

### Leveling Leg and Foot

## S1470C/S1870C/S2070C/S2170C INSTALLATION ON A MANITOWOC BIN

An ice deflector kit is required for installation. Order appropriate kit (30" or 48") for your bin.

### Step 1 Remove the stock ice deflector.

- A. Remove the left and right side cover screws
- B. Remove the cover to expose four screws, which secure the plastic deflector.
- C. Remove four screws and plastic deflector
- D. Install polymer spacer on each side and secure with the four screws.
- E. Reinstall cover and screws.

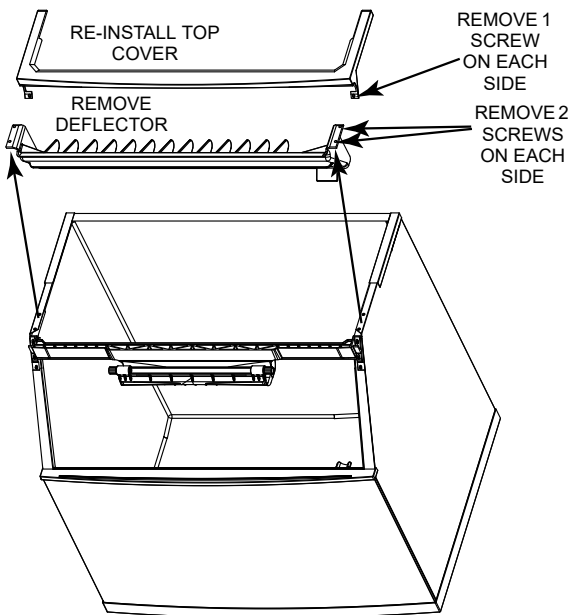

**Step 2** Install front support and filler panels.

- A. Remove foam tape from front support location.
- B. Set front support in place and install foam tape.
- C. Position filler panels (align with front support), drill and secure.
- D. Install foam tape on front and back. Seal all foam tape edges.

**Step 3** Install ice deflector.

- A. Locate center of ice machine drop zone (center is 11" from left edge of ice machine to left edge of bracket).
- B. Cut and remove foam tape on the front and the back of the bin where the deflector will be located.
- C. Remove any residual adhesive; areas must be clean and dry.
- D. Remove protective covering from double sided tape on bottom of deflector bracket.
- E. Install deflector bracket; Distribute equally to the front and back and locate pin to the rear.
- F. Apply foam tape over bracket and seal joints with silicone sealant.
- G. Refer to illustration and install deflector in mounting bracket.

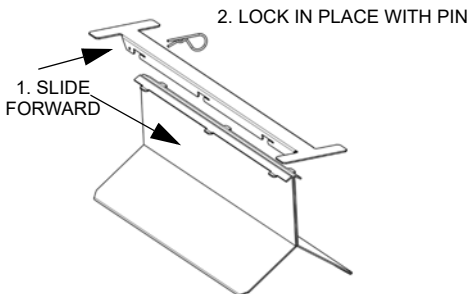

## ICE MACHINE ON A DISPENSER INSTALLATION

No deflector is needed for machines that match the size of the dispenser (30" head section on a 30" dispenser) unless required by the dispenser manufacturer. Adapters are required when a smaller ice machine is going on a larger dispenser (22" machine on a 30" dispenser).

### IB0600C/IB0680C/IB0800C/IB1000C

#### Securing the Ice Machine to the Dispenser

##### **Important**

Manitowoc Ice/Beverage Ice Machines require an adapter for mounting. Adapters are not included with the ice machine, dispenser or bin and must be ordered separately. When a non-Manitowoc adapter is used, verify the adapter is compatible with Manitowoc Ice/Beverage Ice Machines prior to installation.

The ice machine and adapter plate must be secured to the dispenser to prevent tipping.

- Two holes are located in the front bottom rail of the ice machine, to allow attachment to the adapter plate.
- The adapter cover must be secured to the dispenser to prevent ice from dislodging the cover during agitation.



##### **Warning**

The ice machine and adapter plate must be secured to the dispenser to prevent tipping.

## Typical Ice Beverage on a Dispenser

1. Install bin level thermostat bracket.
2. Set adapter on dispenser. Position the adapter so that the front flange of the adapter will be up against the front lip of the dispenser. Adapter may have to be moved towards the back of the dispenser.
3. Using the slotted holes in the adapter as a template, drill four (4) 9/64" diameter holes at the bottom of the slots. Note: Do not drill deeper than 1/4" past the sheet metal. Use a drill stop!
4. Fasten the adaptor to dispenser using the four (4) #8 screws supplied with the adaptor kit.
5. Set the ice machine on top of the adapter. Align holes in ice machine front angle with threaded bosses on the adapter.

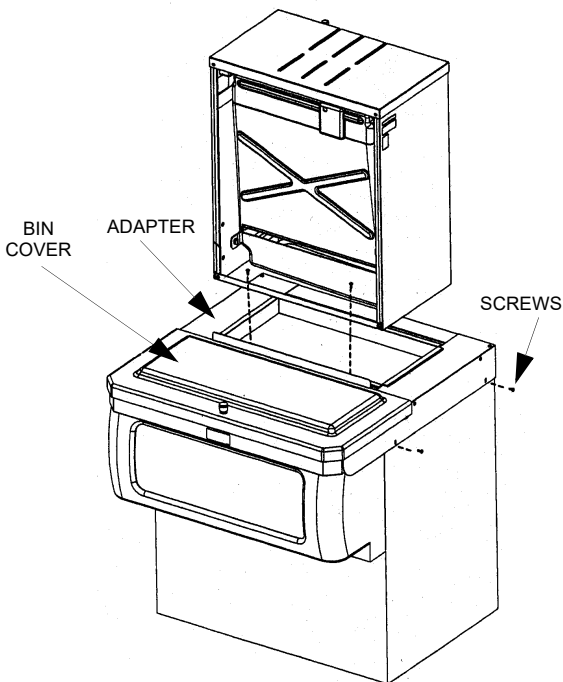

6. Secure the ice machine to the adaptor with two (2) #8-32 screws supplied with the kit.
7. Set the bin cover on the adapter, move backwards until the cover hits the stop, and lower the plastic cover insuring that the latch locks.
8. To remove the bin cover, twist the knob, lift up, and pull forward.

PLACE A LARGE FILLET OF FOOD GRADE RTV INSIDE EDGE ALONG BOTH SIDES WHERE ADAPTER TOUCHES BIN

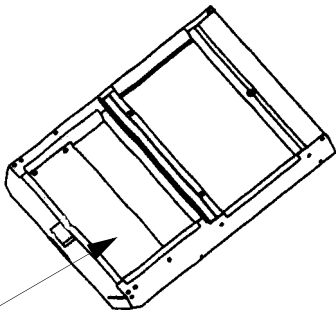
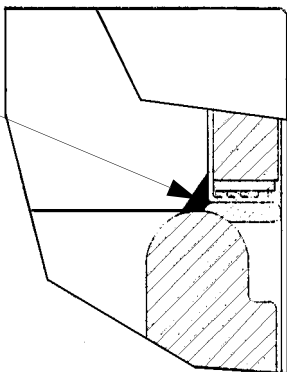

DEFLECTOR MUST STAY IN PLACE

## ICE MACHINE HEAD SECTION WATER SUPPLY AND DRAINS

### Potable Water Supply

Local water conditions may require treatment of the water to inhibit scale formation, filter sediment, and remove chlorine odor and taste.

### Important

If you are installing a Manitowoc water filter system, refer to the Installation Instructions supplied with the filter system for ice making water inlet connections.

### Potable Water Inlet Lines

Follow these guidelines to install water inlet lines:

- Do not connect the ice machine to a hot water supply. Be sure all hot water check valves installed for other equipment are working. (Check valves on sink faucets, dishwashers, etc.)
- If water pressure exceeds the maximum recommended pressure obtain a water pressure regulator from your Manitowoc Distributor.
- Maximum water pressure - 80 psi (551.6 kPa)
- Install a water shut-off valve for ice making potable water.
- Insulate water inlet lines to prevent condensation.
- A 3' service loop or disconnect (union) must be installed at the ice machine head section.

## **Drain Connections**

Follow these guidelines when installing drain lines to prevent drain water from flowing back into the ice machine and storage bin:

- Drain lines must have a 1.5 in. drop per 5 ft. of run (2.5 cm per meter), and must not create traps.
- The floor drain must be large enough to accommodate drainage from all drains.
- Run separate bin and ice machine drain lines. Insulate them to prevent condensation.
- Vent the bin and ice machine drain to the atmosphere. The ice machine drain requires an 18" vent.
- Drains must have a union or other suitable means to allow in place disconnection from the ice machine when servicing is required.
- S3070C/SF3000C require a base drain connection (1" FPT).

## **WATER COOLED CONDENSER WATER SUPPLY AND DRAINS**

### **Cooling Tower Application (Water-Cooled Models)**

A water cooling tower installation does not require modification of the ice machine. The water regulator valve for the condenser continues to control the refrigeration discharge pressure.

It is necessary to know the amount of heat rejection, and the pressure drop through the condenser and water valves (inlet and outlet) when using a cooling tower on an ice machine.

- Water entering the condenser must not exceed 90°F (32.2°C).
- Water flow through the condenser must not exceed 5 gallons (19 liters) per minute.
- Allow for a pressure drop of 7 psi (48 kPA) between the condenser water inlet and the outlet of the ice machine.
- Water exiting the condenser must not exceed 110°F (43.3°C).

#### **Important**

The Commonwealth of Massachusetts requires that all water-cooled models must be connected only to a closed loop, cooling tower system.

## Water Cooled Condenser Lines

Follow these guidelines to install water lines:

- Contact your distributor if your water pressure is greater than 150 psig (1034 kPA). A special order condensing unit is available that allows water pressure up to 350 psig (2413 kPA).
- Install a shutoff valve (inlet and outlet on cooling tower or closed loop circuits) to allow isolation of the water system.
- Water entering the condenser must not exceed 90°F (32.2°C).
- Water flow through the condenser must not exceed 5 gallons (19 liters) per minute.
- Allow for a pressure drop of 8 psig (55 kPA) between the condenser water inlet and outlet.
- Water exiting the condenser must not exceed 110°F (43.3°C).
- Do not connect to the potable water filter system.

## Condensing Unit Drain Connections

The condensing unit drain is provided to remove any condensate produced by the suction accumulator. Condensate amounts will vary depending on temperature and humidity.

- The condensing unit must be level front to back and side to side to allow the condensate to drain.
- Drain lines must have a 1.5-inch drop per 5 feet of run (2.5 cm per meter), and must not create traps.
- Drain termination must meet applicable costs.

## ELECTRICAL REQUIREMENTS

Local or state electrical code, length of wire run or materials used, can increase the minimum wire or breaker size requirement. A qualified electrician must determine the wire and breaker size, although the minimum wire size must meet or exceed the specifications in these charts.

### Head Sections

Ice Machine Head Section			
	Voltage Phase Cycle	Max. Fuse/ Circuit Breaker	Total Amps
<b>S0600C</b> <b>S0680C</b>	115/1/60 208-230/1/60 230/1/50	15 amp 15 amp 15 amp	1.1 0.6 0.6
<b>S0850C</b>	115/1/60 230/1/50	15 amp 15 amp	1.1 1.5
<b>IB0620C</b> <b>IB0680C</b> <b>IB0820C</b> <b>IB1020C</b>	115/1/60 230/1/50	15 amp 15 amp	1.4 0.8
<b>S1000C</b> <b>S1200C</b>	115/1/60 230/1/50	15 amp 15 amp	2.5 1.5
<b>S1470C</b> <b>S1870C</b> <b>S2070C</b> <b>S2170C</b>	115/1/60 208-230/1/60 230/1/50*	15 amp 15 amp 15 amp	1.1 0.6 0.6
<b>S3070C</b> <b>SF3000C</b>	115/1/60 230/50/1	15 amp 10 amp	2.0 2.0

\*Not available on S2070C or S2170C models.  
\*\*All conductors must be solid copper wire.

### Important

The QuietQube® Ice Machine Head Section and CVD® Condensing Unit are wired independently from each other.

## Condensing Units

<b>CVD® Condensing Unit</b>			
	<b>Voltage Phase Cycle</b>	<b>Max. Fuse/ Circuit Breaker</b>	<b>Min. Circuit Amps</b>
<b>CVD0675</b>	208-230/1/60	15 amp	9.6
	208-230/3/60	15 amp	7.3
	230/1/50	15 amp	9.0
<b>CVD0685</b>	208-230/1/60	15 amp	11.0
	208-230/3/60	15 amp	7.5
<b>CVD0885</b>	208-230/1/60	20 amp	11.8
	208-230/3/60	15 amp	9.1
	230/1/50	20 amp	10.0
<b>CVD1075</b>	208-230/1/60	25 amp	15.6
	208-230/3/60	20 amp	10.6
	230/1/50	25 amp	13.8
<b>CVD1085</b>	208-230/1/60	20 amp	12.5
	208-230/3/60	15 amp	9.4
	230/1/50	20 amp	10.9
<b>CVD1185</b>	208-230/1/60	25 amp	15.7
	208-230/3/60	15 amp	10.8
	230/1/50	20 amp	11.2
<b>CVD1285</b>	208-230/1/60	25 amp	14.7
	208-230/3/60	20 amp	10.6
	230/1/50	20 amp	11.7
<b>CVD1485</b>	208-230/1/60	20 amp	20.0
	208-230/3/60	15 amp	15.0
	230/1/50	30 amp	20.0
<b>CVD1486</b>	208-230/1/60	20 amp	20.0
	208-230/3/60	15 amp	15.0
	230/1/50	20 amp	20.0
<b>CVD1885</b>	208-230/1/60	40 amp	25.0
	208-230/3/60	25 amp	20.0
	230/1/50	30 amp	20.0
<b>CVD2085*</b>	208-230/1/60	50 amp	40.0
	208-230/3/60	40 amp	30.0
<b>CVD3085*</b>	208-230/3/60	35 amp	30.0
<b>CVDF3000C*</b>	460/3/50	15 amp	15.0

**\*CVD2085/CVD3085/CVDF3000 Only** - Verify the direction of the rotation is correct on the 3ph scroll compressor. The ice machine will have high suction pressure, low discharge pressure and will be noticeably loud. Reverse two incoming power leads to reverse rotation.

## REFRIGERATION SYSTEM INSTALLATION

QuietQube® Ice Machine	Remote Single Circuit Condenser	Line Set*
S0600C IB0620C	CVD675	RC-21 RC-31 RC-51
S0680C IB0680C	CVD685	
S0850C IB0820C	CVD885	
S1000C IB1020C	CVD1085	
S1200C	CVD1285	RC-20 RC-30 RC-50
IB1020C	CVD1185 CVD1285 CVD1075	
S1470C	CVD1485 CVD1486	
S1870C	CVD1885	
S2070C	CVD2075	
S2170C	CVD2085	RC-23 RC-33 RC-53
S3070C SF3000C	CVD3085 CVDF3000	RC-24 RC-34 RC-54

*Line Set	Suction Line	Liquid Line	Insulation Thickness
RC 21/31/51	5/8 in. (15.9 mm)	3/8 in. (9.5 mm)	Suction Line 1/2" (13mm)  Liquid Line 1/4" (7mm)
RC 20/30/50**	3/4 in. (19.1 mm)	1/2 in. (12.7 mm)	
RC 23/33/53	3/4 in. (19.1 mm)	5/8 in. (15.9 mm)	
RC 24/34/54	Two Lines - 3/4 in. (19.1 mm)	One Line - 5/8 in. (15.9 mm)	

**\*\*NOTE:** The CVD2075 has a suction line fitting of 7/8" and a liquid line fitting of 5/8". Since the line set is sized differently, please use the provided bushings to properly connect the line set to the CVD condensing unit.

## Important

Manitowoc remote systems are only approved and warranted as a complete new package. Warranty on the refrigeration system will be void if a new ice machine head section is connected to pre-existing (used) tubing or condensing units or vice versa.

### Usage With Non-Manitowoc Condensing Units

Manitowoc CVD® Condensing Units are specifically designed for usage with a QuietQube® Ice Machine Head Section. Standard condensing units and Non-Manitowoc condensing units will not operate a QuietQube® Ice Machine Head Section.

### Factory Equipment Refrigerant Amounts

#### ICE MACHINE HEAD SECTION

Each ice machine head section ships from the factory with a R-404A refrigerant charge appropriate for the entire system operation. The serial tag on the ice machine indicates the refrigerant charge. The refrigerant charge is sufficient to operate the ice machine in ambient temperatures between -20°F to 130°F (-28.9°C to 54.4°C)\*. With line set lengths of up to 100 feet (30.5 m).

\***CVD685/CVD1185/CVD2085/CVD3085/CVDF3000** = -20°F to 120°F (-29°C to 49°C)

**CVD1486** = 50°F to 110°F (10°C to 43°C)

### **Caution**

Never add more than nameplate charge to the refrigeration system for any application.

### **Caution**

The 60-month compressor warranty (including the 36-month labor replacement warranty) will not apply if the Manitowoc Ice Machine and Manitowoc CVD® Condensing Unit are not installed according to specifications. This warranty also will not apply if the refrigeration system is modified with a condenser, heat reclaim device, or other parts or assemblies not manufactured by Manitowoc Ice.

 **Warning**

**Potential Personal Injury Situation**

The ice machine head section contains the refrigerant charge. Installation and brazing of the line sets must be performed by a properly trained and EPA certified refrigeration technician aware of the **dangers of dealing with refrigerant** charged equipment.

CVD® CONDENSING UNIT

Each condensing unit ships from the factory pressurized with 50/50 nitrogen helium mixture that must be removed during the installation process (approximately 20 psig).

REFRIGERATION LINE SETS/TRAP KIT

Refrigeration Rated Tubing and Trap Kits are shipped capped with atmospheric pressure.

 **Warning**

Installation of a QuietQube® Condensing Unit may require the use of special equipment for placement. Trained and qualified personnel are required for proper rigging and lifting.

## Refrigeration Line Set Installation

Refrigeration line set installation consists of vertical and horizontal line set distances between the ice machine and the condensing unit. The following guidelines, drawings and calculation methods must be followed to assure proper oil return and CVD® Condensing Unit/ice Machine operation.

The refrigeration line set installer must be USA Government-Environmental Protection Agency (EPA) certified in proper refrigerant handling and servicing procedures.

### **Warning**

The ice machine head section contains refrigerant charge. The ice machine head section contains three (3) refrigeration valves that **must remain closed** until proper installation of the line sets is completed.

### **Warning**

Disconnect electrical power to the ice machine head section and CVD® condensing unit before proceeding.

### VERIFY ICE MACHINE AND CVD® CONDENSING UNIT LOCATIONS ARE WITHIN GUIDELINES.

Prior to installation of the ice machine and CVD® Condensing Unit be sure that the distance between them is within the line set routing guidelines outlined in this manual.

### **Roof/Wall Penetration**

If required, cut a 3-inch (76.2 mm) circular hole in the wall or roof for routing of refrigeration tubing. A qualified person must perform all roof penetrations.

### ROUTE REFRIGERATION TUBING

Properly route refrigeration tubing between the ice machine head section and the CVD® condensing unit.

## A. LINE SET LENGTH

### **Caution**

QuietQube® Ice Machines will not function with line sets greater than 100 ft. (30.5 m). Do not attempt to go beyond this distance and add refrigerant charge to compensate!

**100 feet (30.5 m) Length:** The maximum measured length the line set can be.

The receiver is designed to hold a charge sufficient to operate the ice machine in ambient temperatures between -20°F (-28.9°C) and 130°F (54.4°C)\*, with line set lengths of up to 100 feet (30.5 m).

**\*CVD685/CVD1185/CVD2085/CVD3085 =**  
-20°F to 120°F (-29°C to 49°C)

**CVD1486 = 50°F to 110°F (10°C to 43°C)**The maximum amount of lineset which can be exposed on the rooftop is 25% of the total length of the lineset.

### **Important**

QuietQube® ice machines will not function with line sets greater than 100 feet (30.5 m). Do not attempt to go beyond this distance and add refrigerant charge to compensate!

## B. Line Set Rise or Drop

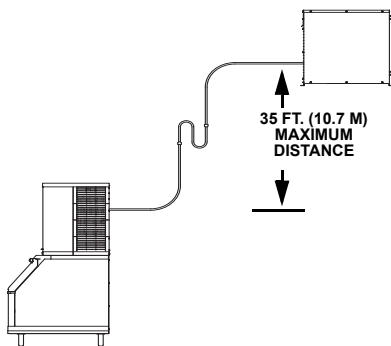

SV1751

**35 ft. (10.7 m) Rise:** The maximum distance the CVD® Condensing Unit can be above the ice machine.

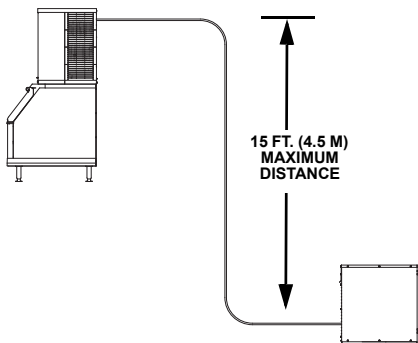

SV1750

**15 ft. (4.5 m) Drop:** The maximum distance the CVD® Condensing Unit can be below the ice machine.

## C. Suction Line Oil Traps

### **Caution**

Do not form unwanted traps in refrigeration lines. Never coil excess refrigeration tubing.

**0 to 20 ft. (0 to 6.1 m) Rise:** The ice machine head section has one oil trap built in which allows for a maximum condenser rise of 20 ft. (6.1 m) without additional traps in the suction line.

**21 to 35 ft. (6.4 to 10.7 m) Rise:** The suction line requires an additional oil trap ("S" type) to be installed. Install the trap as close as possible to midpoint between the ice machine head section and CVD® Condensing Unit. S-Trap Kits are available from Manitowoc (refer to chart).

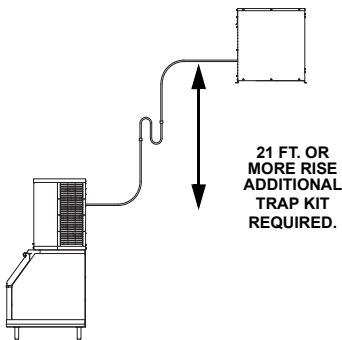

### MANITOWOC S-TRAP KIT

Model	S-Trap Kit Number	Tubing Size
S600C IB600C S680C IB680C S850C IB800C S1000C	K00172	5/8 inch (15.9 mm)
IB1000C S1200C S1470C S1870C S2070C S2170C S3070C* SF3000C*	K00166	3/4 inch (19.1 mm)

\* Requires two S-Trap kits, one for each suction line.

## SERVICE LOOP

- **The supplied service loop (on Ice Beverage ice machines) is an installation requirement. Excess tubing length must be sufficient to allow 180° rotation of the ice machine.**
- A service loop is not considered an oil trap.
- The service loop is not included when calculating length, rise or drop of the tubing run.
- Do not use hard rigid copper for the service loop.

### **Caution**

If a line set has a rise followed by a drop, another rise cannot be made. Likewise, if a line set has a drop followed by a rise, another drop cannot be made.

#### **Step 4** Lengthening or Reducing Line Set Lengths

When the line set requires shortening or lengthening, do so before connecting the line set to the ice machine head section or the CVD® Condensing Unit.

### **Caution**

Do not form unwanted traps in refrigeration lines. Never coil excess refrigeration tubing.

#### **Step 5** Connecting the line set.

To prevent oxidation of the copper, purge line set and condensing unit with dry nitrogen while brazing.

### **Warning**

The ice machine head section contains refrigerant charge. The ice machine head section contains three (3) refrigeration valves that **must remain closed** until proper installation of the line sets is completed.

## CONNECT THE LINE SET TO THE ICE MACHINE HEAD SECTION

The line set can be routed for entry through the top or rear of the ice machine head section.

- Top routing requires the cover to be trimmed.
- Rear routing requires the use of the supplied 90° elbows.

The line set shut-off valves at the back of the ice machine must remain closed and be protected from heat during the brazing process. Wrap the valves in a wet rag or other type of heat sink prior to brazing. Cool braze joint with water immediately after brazing to prevent heat migration to the valve.

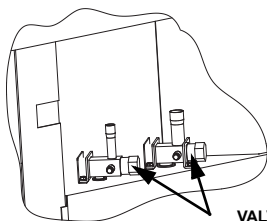

**VALVES MUST REMAIN CLOSED AND BE PROTECTED FROM HEAT WHEN BRAZING (WRAP WITH WET RAG)**

## CONNECT THE LINE SET TO THE CVD® - CONDENSING UNIT

### **Warning**

The condensing unit ships from the factory pressurized with a 50/50 mixture of nitrogen/helium. Bleed off pressure from both suction and liquid line access ports prior to cutting into refrigeration lines.

The compressor oil rapidly absorbs moisture. **Be prepared** to complete line set installation and start your evacuation process in order to minimize the time the compressor is exposed to the atmosphere. (Maximum amount of time the system can be exposed to the atmosphere is 15 minutes.)

The line set can be routed for entry through the front or left side of the condensing unit.

- Remove knockout for side location.
- Insert supplied plastic bushings in knockout holes to prevent tubing from contacting sheet metal.
- Use the supplied 90° elbows to route tubing.
- Cut the tubing ends of the suction and liquid lines and braze line sets to the condensing unit.
- **S3070C/SF3000C Only** - use the provided tee to connect the 2 suction lines from the head section to the suction line on the condensing unit.

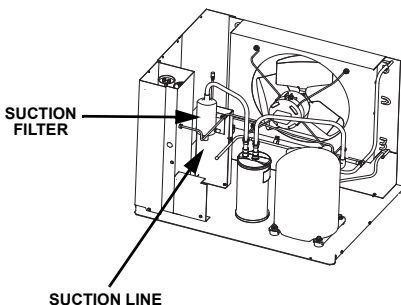

**MINIMIZE THE TIME THE REFRIGERATION  
SYSTEM IS EXPOSED TO THE ATMOSPHERE  
(15 MINUTES MAXIMUM).**

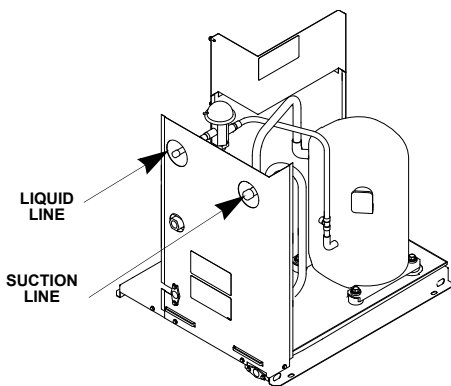

**S3070C/SF3000C  
TUBING MUST BE  
CONNECTED TO  
TEE AS SHOWN**

**SUCTION LINE ON  
CONDENSING UNIT**

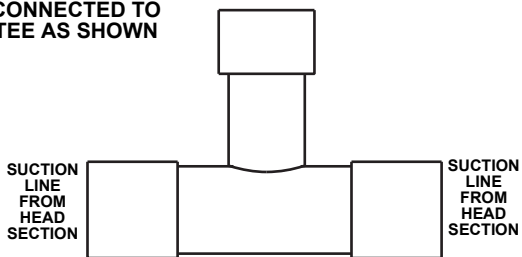

## PRESSURE TEST AND EVACUATE THE LINE SET AND CVD CONDENSING UNIT

Schrader valve core removal tools that allow for removal and installation of the valve cores without removing manifold gauge set hoses are recommended to decrease the evacuation time.

Leave the line set shut-off valves closed (front seated).

**All CVD condensing units manufactured after December 2009 contain a check valve in the compressor discharge line.** The check valve requires an additional connection on the condensing unit during evacuation and recovery procedures.

Connections are required at five points:

Ice Machine Head Section

1. Receiver Service Valve
2. Low Side Access Valve
3. High Side Access Valve

CVD Condensing Unit

4. Compressor Discharge Access Valve
5. Suction Filter Access Valve

Connection of a manifold gauge set (or a hose with core depressors on both ends) between the suction filter access port and the compressor access valve (located between the compressor and discharge line check valve) is required.

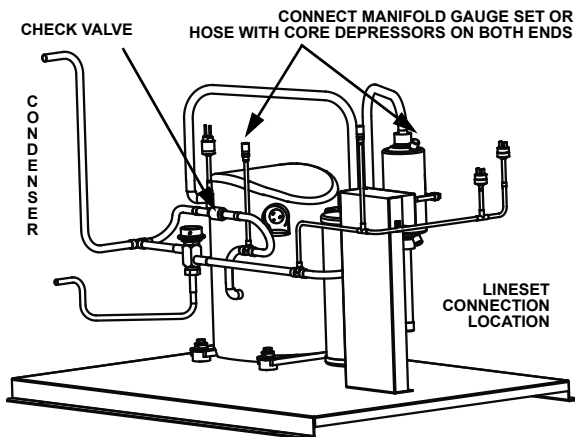

Pressure test the line sets and CVD® Condensing Unit with 150 psig of dry nitrogen. Add nitrogen at the line set shut-off valves located at the back of the ice machine head section or from the schrader valves located in the CVD® Condensing Unit. Complete the pressure test, verify no leaks are present and remove the nitrogen from the system before connecting the vacuum pump.

Connect a vacuum pump to both of the line set shut-off valves located at the back of the ice machine head section or from the schrader valves located in the CVD® Condensing Unit. Schrader valve core removal tools (that allow for putting the cores back in without removing vacuum pump hoses) will greatly decrease evacuation time.

Evacuate to 500 microns (or less) at the CVD condensing unit.

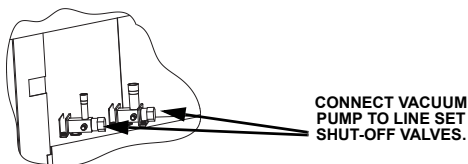

**ALTERNATE CONNECTIONS AT  
CONDENSING UNIT SCHRADER VALVES**

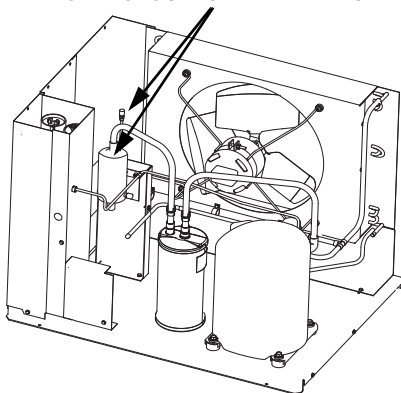

Isolate the vacuum pump from the line set shut-off valves and/or condensing unit access ports prior to proceeding.

## OPEN REFRIGERATION SERVICE VALVES

The suction line, liquid line and receiver service valves are closed during shipment and installation.

Open the valves prior to starting the ice machine.

- A. Slowly backseat (open – turn counterclockwise) the suction line shut-off valve.
- B. Slowly backseat (open – turn counterclockwise) the liquid line shut-off valve.
- C. Slowly backseat (open-turn counterclockwise) the receiver service valve.

NOTE: You will not hear refrigerant flow when the valves are opened. Refrigerant will not flow until the toggle switch is placed in the ice position and the solenoid valve opens.

## **OPEN SUCTION AND LIQUID LINE SHUT OFF VALVES**

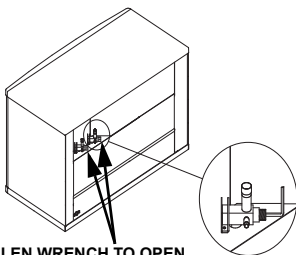

USE ALLEN WRENCH TO OPEN  
(TURN COUNTERCLOCKWISE)  
LIQUID AND SUCTION LINE  
SHUT-OFF VALVES.

**S600C/S680C/S850C/S1000C/S1200C**

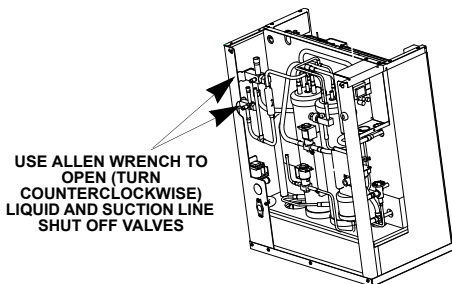

USE ALLEN WRENCH TO  
OPEN (TURN  
COUNTERCLOCKWISE)  
LIQUID AND SUCTION LINE  
SHUT OFF VALVES

**IB Series**

**USE ALLEN WRENCH TO  
OPEN (TURN  
COUNTERCLOCKWISE)  
LIQUID AND SUCTION LINE  
SHUT OFF VALVES**

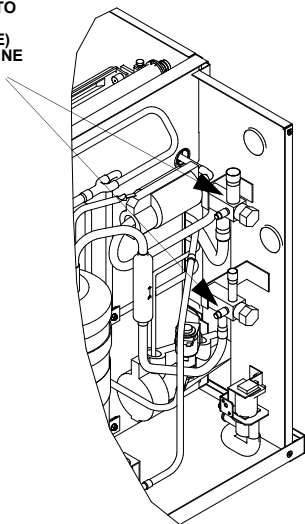

**OPEN SUCTION AND LIQUID LINE SHUT OFF VALVES  
S1470C/S1870C/S2070C/S2170C**

USE ALLEN WRENCH  
TO OPEN (TURN  
COUNTERCLOCKWISE)  
LIQUID AND SUCTION  
LINE SHUT OFF  
VALVES

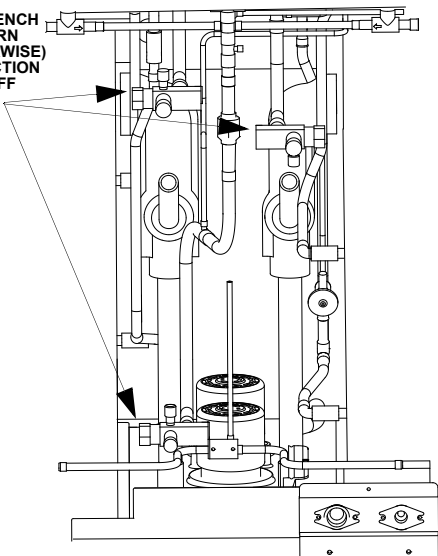

**S3070C/SF3000C**

**⚠ Caution**

After opening suction, discharge and receiver service valves, refrigerant pressure will not be detected until the toggle switch is placed in the ice position and the harvest valve energizes.

**Important**

All refrigeration valve caps must be reinstalled to prevent future refrigeration leaks.

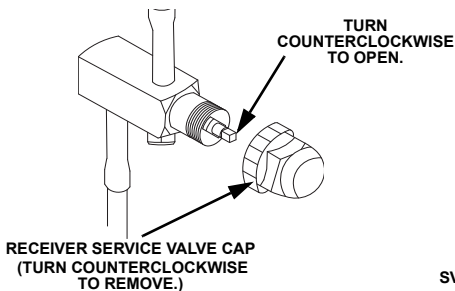

SV1756

## RECEIVER SERVICE VALVE

Verify O-rings in schrader valve caps are intact and reinstall on shut-off valves to prevent refrigerant leakage. Replace shut-off valve access caps and torque to the following specifications.

Torque Values	
Stem	18-20 ft. lbs.
Caps	12-15 ft. lbs.
Schrader Core	1.5-3 in. lbs.

Replace cap on receiver service valve and tighten. There is a liquid line solenoid valve at the outlet of the receiver; refrigerant will not flow to the condensing unit until the ice machine head section is started. Connect power to both the ice machine head section and the CVD® Condensing Unit. Place the ice machine toggle switch into the ICE position; this will allow refrigerant to enter the line set and condensing unit.

### LEAK CHECK THE REFRIGERATION SYSTEM

Leak check the new line set connections at the ice machine head section, condensing unit and S-trap as well as all factory joints throughout the entire system. Disconnect power to the CVD® Condensing Unit. Place the ICE/OFF/CLEAN toggle switch in the ICE position. This allows the low side and high side pressures to equalize. Place the ICE/OFF/CLEAN toggle switch in the OFF position. Connect power to the CVD® Condensing Unit and allow system to pump down.

## INSULATION REQUIREMENTS

To prevent condensation, the entire suction line including the shut-off valve must be insulated. All insulation must be airtight and sealed at both ends.

The following insulation requirements prevent condensation at 90°F (32.2°C) ambient 90% Relative Humidity. If higher humidity is expected, increase insulation thickness.

The entire suction line set, including the suction service valve located on the back of the ice machine, requires:

<b>Suction Line</b>	<b>Liquid Line</b>	<b>Min. Insulation Thickness</b>
3/4 inch (19.1 mm)	1/2 inch (12.7 mm)	1/2"(13mm) Suction Line 1/4" (7mm) Liquid Line
5/8 inch (15.9 mm)	3/8 inch (9.5 mm)	
3/4 inch (19.1 mm)	5/8 inch (15.9 mm)	

### **Important**

To prevent condensation the entire suction line including the shut off valve must be insulated. All insulation must be airtight and sealed at both ends. The minimum requirements are for conditions at or below 90% humidity and 90°F (32.2°C) ambient. When higher humidity will be experienced, insulation wall thickness will need to be increased.

## Suction Shut-off Valve Insulation

The preformed suction shut-off valve insulation is located in the plastic bag taped to the water curtain.

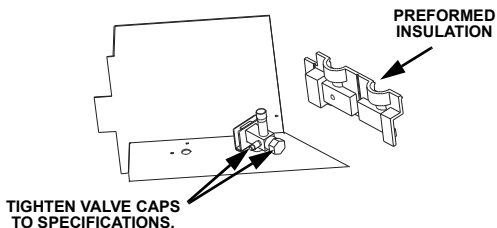

- A. Verify valve and schrader caps are tightened to specifications (see step 6).

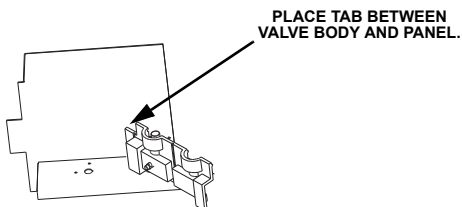

- B. Place insulation over schrader valve cap and left side of valve. Position the tab between the mounting bracket and rear panel.

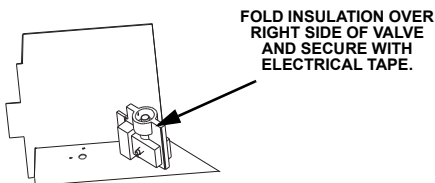

- C. Fold insulation and hold against right hand side of valve while securing with electrical tape. Seal the line set insulation to the shut-off valve insulation with electrical tape.

## Operational Checks

### GENERAL

Your Manitowoc ice machine was factory-operated and adjusted before shipment. Normally, a newly installed ice machine does not require any adjustment.

To ensure proper operation, always perform these Operational Checks when starting the ice machine:

- For the First Time
- After a Prolonged Out-of-Service Period
- After Cleaning and Sanitizing

Routine adjustments and maintenance procedures outlined in this manual are not covered by the warranty.

### WATER LEVEL

The water level sensor is set to maintain the proper water level above the water pump housing. The water level is not adjustable.

If the water level is incorrect, check the water level probe for damage (probe bent, etc.). Clean, repair or replace the probe as necessary.

## ICE THICKNESS CHECK

After a harvest cycle, inspect the ice cubes in the ice storage bin. The ice thickness probe is factory-set to maintain the ice bridge thickness at 1/8" (3.2 mm).

**NOTE:** Make sure the water curtain is in place when performing this check. It prevents water from splashing out of the water trough.

1. Inspect the bridge connecting the cubes. It should be about 1/8" (3.2 mm) thick.
2. If adjustment is necessary, turn the ice thickness probe adjustment screw clockwise to increase bridge thickness, counterclockwise to decrease bridge thickness. Set at 1/4" gap between ice machine and evaporator as starting point, then adjust to achieve a 1/8" bridge thickness.

**NOTE:** Turning the adjustment 1/3 of a turn will change the ice thickness about 1/16" (1.5 mm).

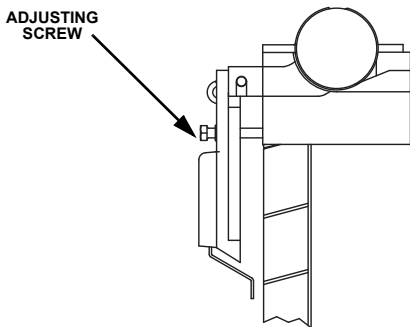

1/8" ICE BRIDGE THICKNESS

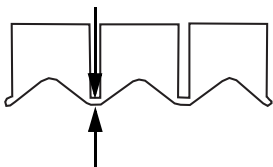

**ICE THICKNESS ADJUSTMENT**

3. Make sure the ice thickness probe wire and bracket do not restrict movement of the probe.

## HARVEST SEQUENCE WATER PURGE

The Harvest sequence water purge adjustment may only be used when the ice machine is hooked up to special water systems, such as a reverse osmosis or de-ionized water treatment system.

### **Warning**

Disconnect electric power to the ice machine at the electrical disconnect before proceeding.

### **Important**

The Harvest sequence water purge is factory-set at 45 seconds. A shorter purge setting (with standard water supplies such as city water) is not recommended. This can increase water system cleaning and sanitizing requirements.

- The Harvest sequence water purge may be set to 0 or 45 seconds. Repositioning the jumper will set the harvest water purge to 0 seconds. This setting does not affect the SeCs or AuCS (cleaning) sequences.
- During the Harvest sequence water purge, the water fill valve energizes and de-energizes by time. The water purge must be at the factory setting of 45 seconds for the water fill valve to energize during the last 15 seconds of the water purge. If it is set to 0 seconds, the water fill valve will not energize during the water purge.

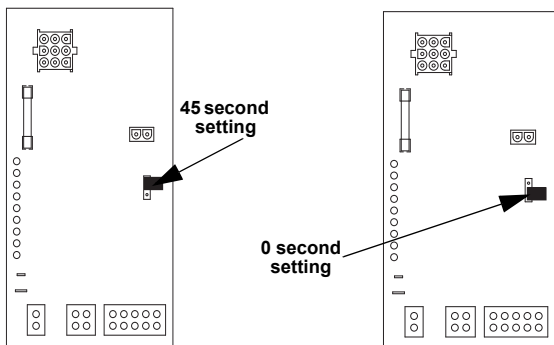

## Electronic Bin Thermostat Instructions IB600C/IB680C/IB800C/IB1000C Only

### POSITIONING

1. Remove water trough.
2. Refer illustration below.
  - A. Loosen rear screw.
  - B. Remove front screw & rotate probe/bracket.
  - C. Re-install front screw & tighten.
  - D. Tighten rear screw.
3. Re-install water trough.
4. Remove slack from sensor probe wire and verify wire does not contact or obstruct the water curtain or water level probe.
5. The control is preset and does not require programming.  
For control specifications refer to page page 187.

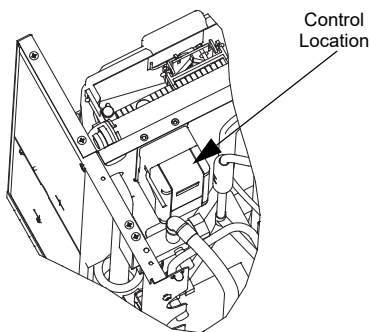
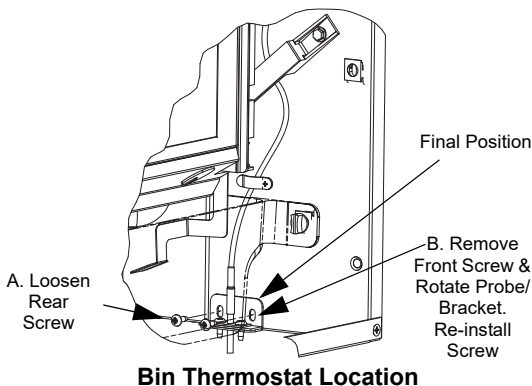

**This Page Intentionally Left Blank**

# Component Identification

## ICE MACHINE HEAD SECTIONS

S600C/S680C/S850C/S1000C/S1200C

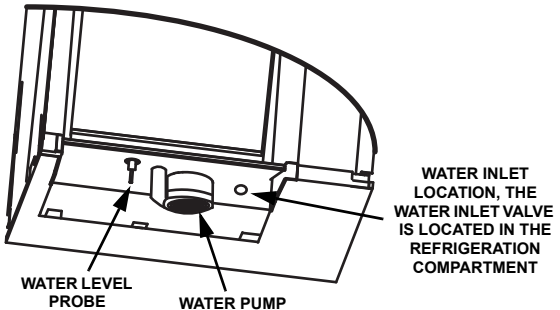
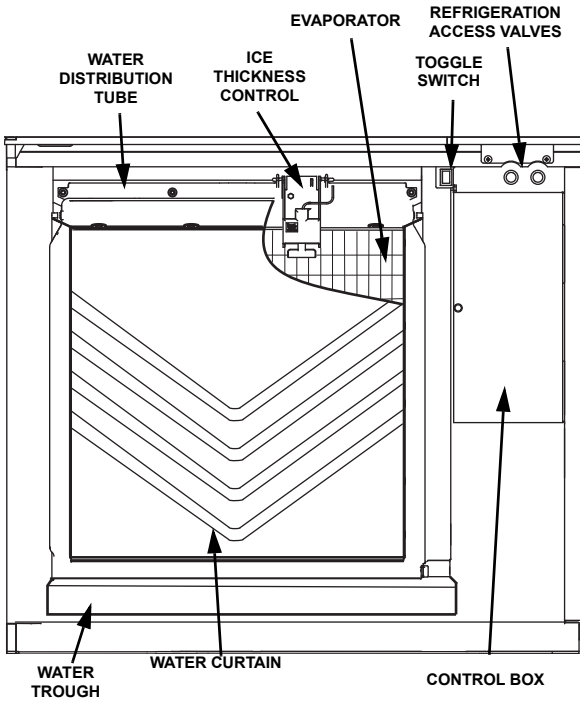

# S1470C/S1870C/S2070C/S2170C

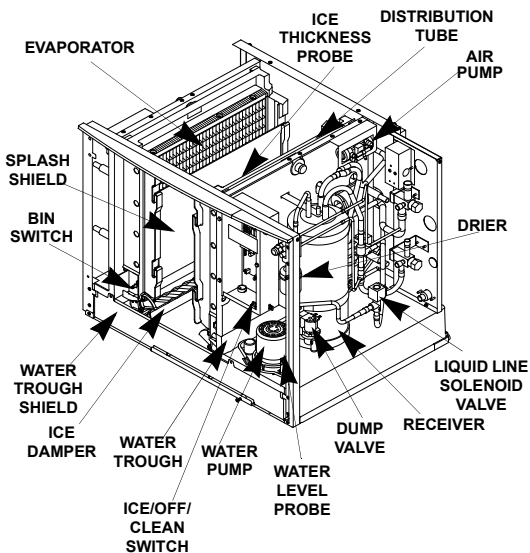

LEFT SIDE

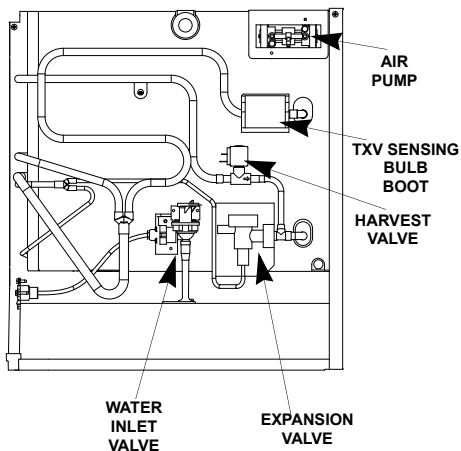

# IB0600C/IB0680C/IB0800C/IB1000C

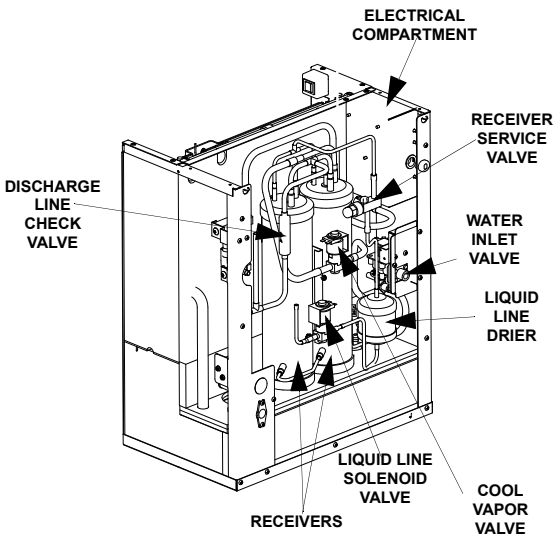
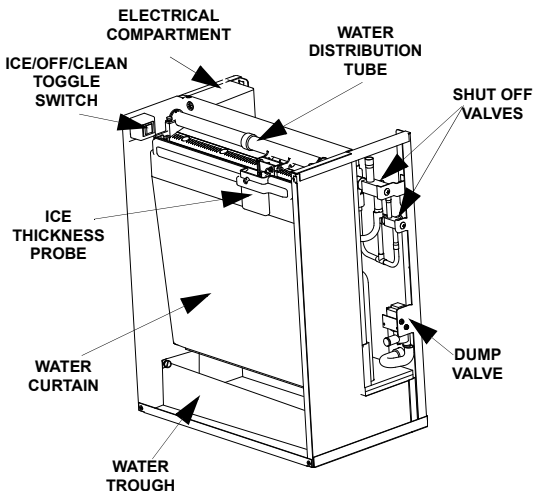

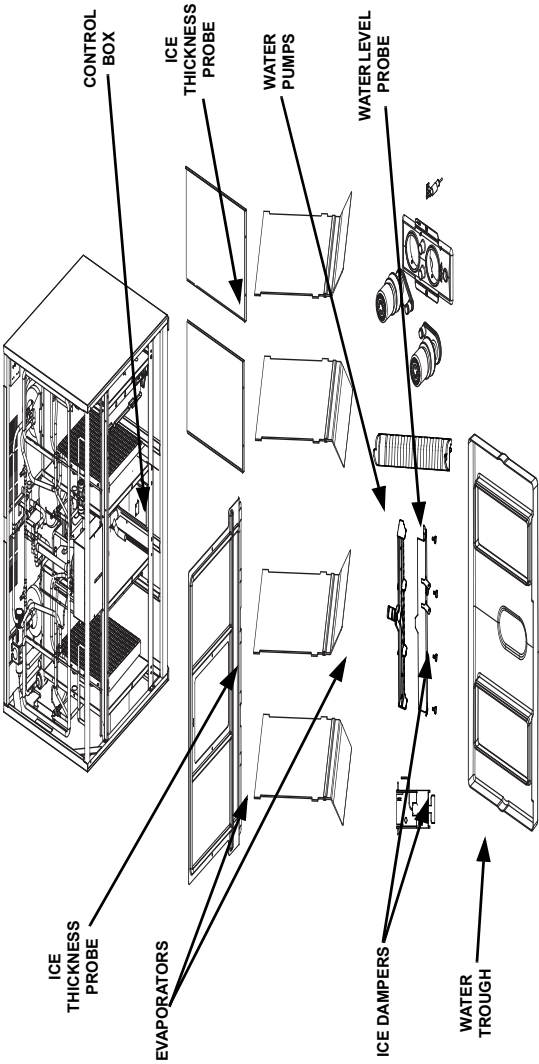

## CVD® CONDENSING UNITS

CVD675/CVD685/CVD875/CVD885/CVD1075/CVD1085/  
CVD1185/CVD1285/CVD1485

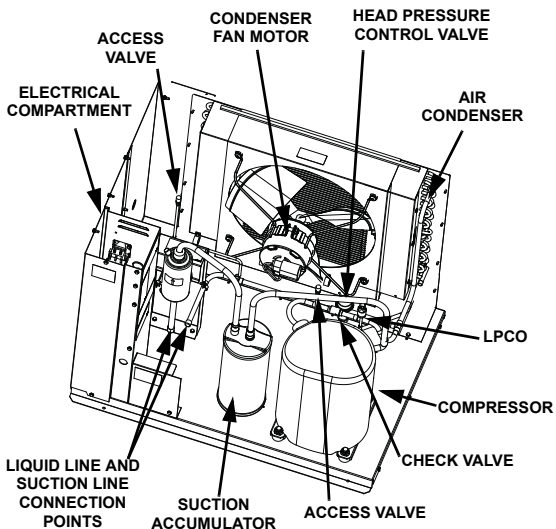

### CVD1486

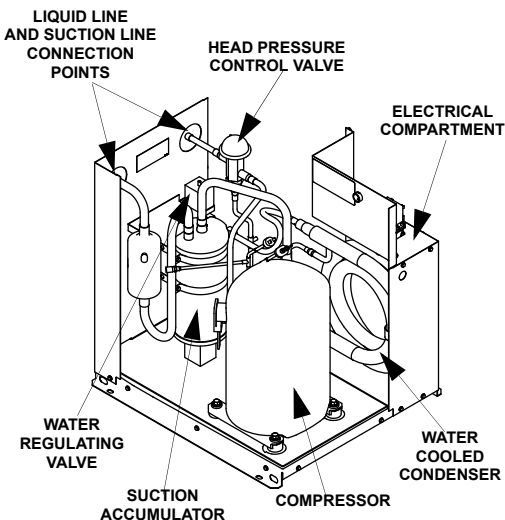

**CVD1885/CVD2075/CVD2085/CVD3085/CVDF3000**

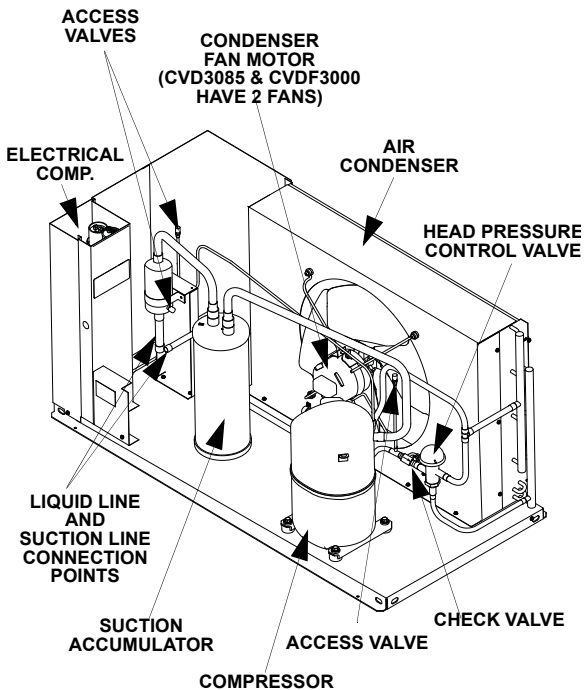

# Maintenance

---

## General

Clean and sanitize the ice machine every six months for efficient operation. If the ice machine requires more frequent cleaning and sanitizing, consult a water care professional to test the water quality and recommend appropriate water treatment. An extremely dirty ice machine must be taken apart for cleaning and sanitizing.

Manitowoc Ice Machine Cleaner and Sanitizer are the only products approved for use in Manitowoc ice machines.

This Manitowoc Ice Machine has two separate cleaning procedures.

### Cleaning/Sanitizing Procedure

This procedure must be performed a minimum of once every six months.

- The ice machine and bin must be disassembled cleaned and sanitized
- All ice produced during the cleaning and sanitizing procedures must be discarded
- Removes mineral deposits from areas or surfaces that are in direct contact with water

### Heavily Scaled Cleaning Procedure

Perform this procedure if you have some or all of these symptoms.

- An IB600C/IB680C/IB800C/IB1000C
- Ice machine stops on Safety Shutdown
- Your water has a high concentration of minerals
- The ice machine has not been on a regular maintenance schedule.

## Cleaning / Sanitizing Procedure

### **Caution**

Use only Manitowoc approved Ice Machine Cleaner and Sanitizer for this application (Manitowoc Cleaner part number 9405463 and Manitowoc Sanitizer part number 9405653). It is a violation of Federal law to use these solutions in a manner inconsistent with their labeling. Read and understand all labels printed on bottles before use.

## CLEANING PROCEDURE

### **Caution**

Do not mix Cleaner and Sanitizer solutions together. It is a violation of Federal law to use these solutions in a manner inconsistent with their labeling.

### **Warning**

Wear rubber gloves and safety goggles (and/or face shield) when handling ice machine Cleaner or Sanitizer.

Ice machine cleaner is used to remove lime scale and mineral deposits. Ice machine sanitizer disinfects and removes algae and slime.

**NOTE:** IB Models must be cleaned using the procedure on page 85.

**Step 1** Remove front door and top cover. This will allow easiest access for adding cleaning and sanitizing solutions.

**Step 2** Set the toggle switch to the OFF position after ice falls from the evaporator at the end of a Harvest cycle. Or, set the switch to the OFF position and allow the ice to melt off the evaporator.

 **Caution**

Never use anything to force ice from the evaporator. Damage may result.

**Step 3** Remove all ice from the bin.

**Step 4** Place the toggle switch in the CLEAN position. The water will flow through the water dump valve and down the drain. Wait until the water trough refills and water flows over the evaporator, then add the proper amount of ice machine cleaner.

Model	Amount of Cleaner
S0600C/S0680C/S0800C S1000C/S1200C	5 ounces (150 ml)
S1470C/S1870C/ S2070C/S2170C	9 ounces (270 ml)
S3070C/SF3000C	16 ounces (475 ml)

**Step 5** Wait until the clean cycle is complete (approximately \*35 minutes). then place the toggle switch in the OFF position and disconnect power to the ice machine (and dispenser when used).

NOTE: \*S307C/SF3000C - 80 minutes.

 **Warning**

Disconnect the electric power to the ice machine at the electric service switch box.

**Step 6** Remove parts for cleaning.

**Please refer to the proper parts removal for your ice machine.**

**S600C/S680C/S850C/S1000C/S1200C - page 70.**

**S1470C/S1870C/S2070C/S2170C - page 71.**

**S3070C/SF3000C - page 74.**

## PARTS REMOVAL FOR CLEANING/ SANITIZING

### S600C/S680C/S850C/S1000C/S1200C

#### A. Remove the water curtain

- Gently flex the curtain in the center and remove it from the right side.
- Slide the left pin out.

#### B. Remove the ice thickness probe

- Compress the hinge pin on the top of the ice thickness probe.
- Pivot the ice thickness probe to disengage one pin then the other. The ice thickness probe can be cleaned at this point without complete removal. If complete removal is desired, disconnect the ice thickness control wiring from the control board.

#### C. Remove the water trough

- Depress tabs on right and left side of the water trough.
- Allow front of water trough to drop as you pull forward to disengage the rear pins.

NOTE: Proceed to page 76, Step 7.

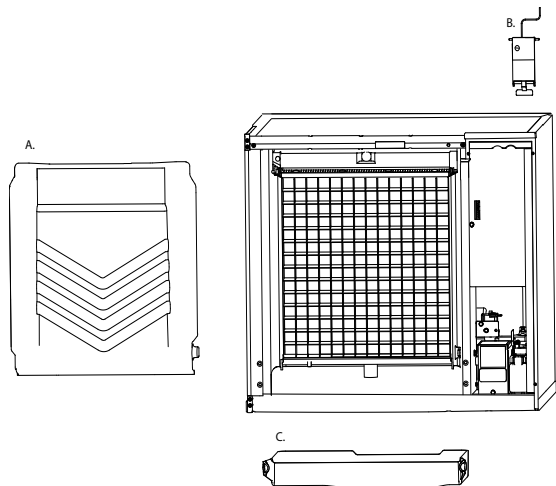

## **S1470C/S1870C/S2170C**

### **A. Remove Splash Shields.**

- Grasp the top center of splash shields.
- Lift up and then out.

### **B. Remove ice thickness probe.**

- Compress the hinge pin on the top of the ice thickness probe.
- Pivot the ice thickness probe to disengage one pin then the other. The ice thickness probe can be cleaned at this point without complete removal. If complete removal is desired, disconnect the ice thickness control wiring from the control board.

### **C. Remove the water trough shield.**

- Grasp the water trough shield in the center and the left end.
- Flex the water trough shield in the center and pull the left end forward until clear of the side wall. Repeat for the right end.
- Pull water trough shield forward to remove.

### **D. Remove the water trough.**

- Depress the two tabs on the top of the water trough.
- Turn left and right ice dampers down to clear water trough.
- Pull forward on the water trough to remove.

NOTE: Proceed to page 76, Step 7.

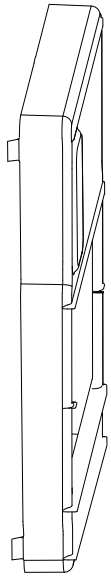
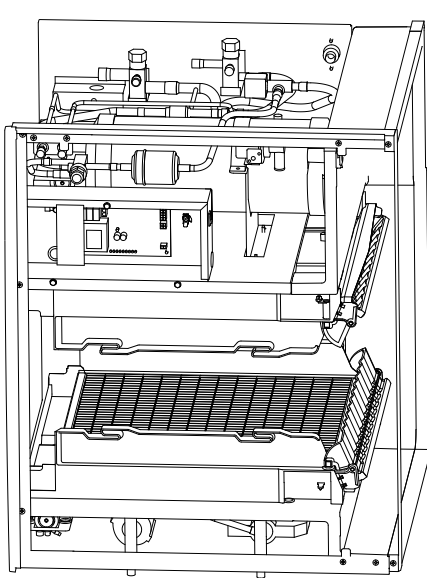

D.

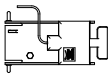

B.

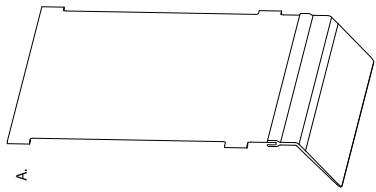
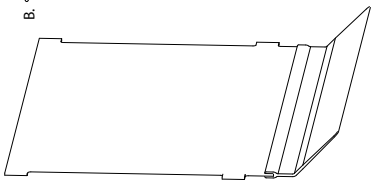

A.

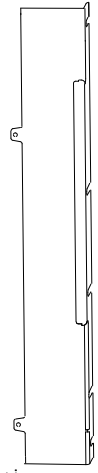

C.

## **S3070C/SF3000C**

### **A.Remove front evaporator shield.**

- Remove four quarter turn connectors
- Remove splash shield

### **B.Remove Splash Shields.**

NOTE: Each evaporator has a splash shield that must be removed - total of four splash shields.

- Grasp the top center of splash shields.
- Lift up and then out.

### **C. Remove ice thickness probe.**

- Compress the hinge pin on the top of the ice thickness probe.
- Pivot the ice thickness probe to disengage one pin then the other. The ice thickness probe can be cleaned at this point without complete removal. If complete removal is desired, disconnect the ice thickness control wiring from the control board.

### **D. Remove the water pump assembly.**

- Disconnect the vinyl distribution tube from both water pumps.
- Disconnect the water pump and water level probe electrical connections.
- After the wires are disconnected remove the two thumbscrews and lift the water pump assembly out of the ice machine.

### **E. Remove the water trough.**

- Pull forward on the water trough to remove.

NOTE: Proceed to page 76, Step 7.

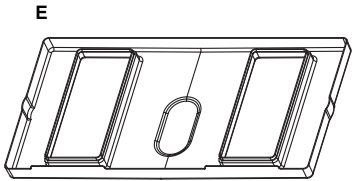
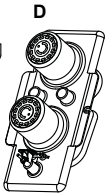
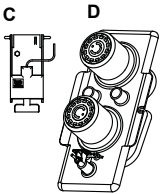
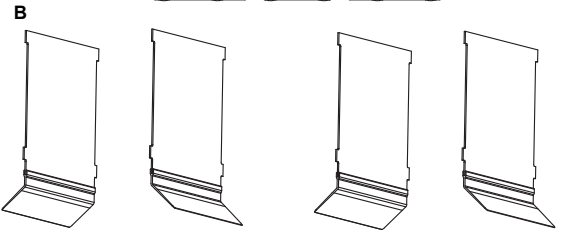
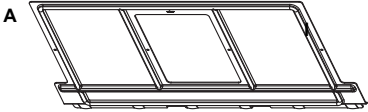
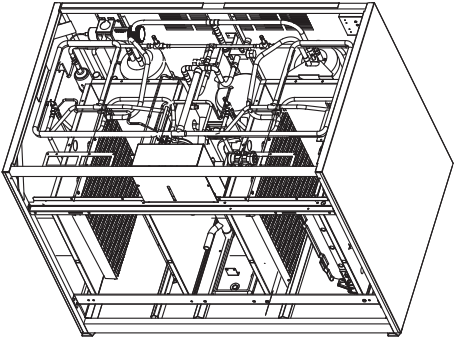

**Step 7** Mix a solution of cleaner and warm water. Depending upon the amount of mineral buildup, a larger quantity of solution may be required. Use the ratio in the table below to mix enough solution to thoroughly clean all parts.

<b>Solution Type</b>	<b>Water</b>	<b>Mixed With</b>
Cleaner	1 gal. (4 l)	16 oz (500 ml) cleaner

**Step 8** Use 1/2 of the cleaner/water mixture to clean all components. The cleaner solution will foam when it contacts lime scale and mineral deposits; once the foaming stops use a soft-bristle nylon brush, sponge or cloth (NOT a wire brush) to carefully clean the parts. Soak parts for 5 minutes (15 - 20 minutes for heavily scaled parts). Rinse all components with clean water.

**Step 9** While components are soaking, use 1/2 of the cleaner/water solution to clean all food zone surfaces of the ice machine and bin (or dispenser). Use a nylon brush or cloth to thoroughly clean the following ice machine areas:

- Side walls
- Base (area above water trough)
- Evaporator plastic parts - including top, bottom, and sides
- Bin or dispenser

Rinse all areas thoroughly with clean water.

## SANITIZING PROCEDURE

**Step 10** Mix a solution of sanitizer and warm water.

Solution Type	Water	Mixed With
Sanitizer	6 gal. (23 l)	4 oz (120 ml) sanitizer

**Step 11** Use 1/2 of the sanitizer/water solution to sanitize all removed components. Use a spray bottle to liberally apply the solution to all surfaces of the removed parts or soak the removed parts in the sanitizer/water solution. Do not rinse parts after sanitizing.

**Step 12** Use 1/2 of the sanitizer/water solution to sanitize all food zone surfaces of the ice machine and bin (or dispenser). Use a spray bottle to liberally apply the solution. When sanitizing, pay particular attention to the following areas:

- Side walls
- Base (area above water trough)
- Evaporator plastic parts - including top, bottom and sides
- Bin or dispenser

Do not rinse the sanitized areas.

**Step 13** Replace all removed components.

**Step 14** Wait 30 minutes.

**Step 15** Reapply power to the ice machine and place the toggle switch in the CLEAN position.

**Step 16** Wait until the water trough refills and water flows over the evaporator (approximately 3 minutes). Add the proper amount of Manitowoc Ice Machine Sanitizer to the water trough by pouring between the water curtain/splash shields and evaporator.

<b>Model</b>	<b>Amount of Sanitizer</b>
S0600C/S0680C/S0800C S1000C/S1200C	3 ounces (90 ml)
S1470C/S1870C/ S2070C/S2170C	12 ounces (355 ml)
S3070C/SF3000C	25 ounces (740 ml)

**Step 17** Move the toggle switch to the ICE position and replace the front panel. The ice machine will automatically start ice making after the sanitize cycle is complete (approximately 35 minutes, S3070C/SF3000C - 80 minutes).

## Procedure to Clean Heavily Scaled Ice Machines

IB models and Ice machines that are heavily scaled or have not been cleaned on a regular basis will need to run this procedure.

### GENERAL

Clean and sanitize the ice machine every six months for efficient operation. If the ice machine requires more frequent cleaning and sanitizing, consult a qualified service company to test the water quality and recommend appropriate water treatment. The ice machine must be taken apart for cleaning and sanitizing.

#### **Caution**

Use only Manitowoc approved Ice Machine Cleaner and Sanitizer for this application (Manitowoc Cleaner part number [9405463](#) and Manitowoc Sanitizer part number [9405653](#)). It is a violation of Federal law to use these solutions in a manner inconsistent with their labeling. Read and understand all labels printed on bottles before use.

### CLEANING PROCEDURE

#### **Caution**

Do not mix Cleaner and Sanitizer solutions together. It is a violation of Federal law to use these solutions in a manner inconsistent with their labeling.

#### **Warning**

Wear rubber gloves and safety goggles (and/or face shield) when handling ice machine Cleaner or Sanitizer.

Ice machine cleaner is used to remove lime scale and mineral deposits. Ice machine sanitizer disinfects and removes algae and slime.

**Step 1** Remove front door and top cover. This will allow easiest access for adding cleaning and sanitizing solutions.

**Step 2** Set the toggle switch to the OFF position after ice falls from the evaporator at the end of a Harvest cycle. Or, set the switch to the OFF position and allow the ice to melt off the evaporator.

 **Caution**

Never use anything to force ice from the evaporator. Damage may result.

**Step 3** Remove all ice from the bin/dispenser.

**Step 4** Place the toggle switch in the CLEAN position. The water will flow through the water dump valve and down the drain. Wait until the water trough refills and water flows over the evaporator, then add the proper amount of ice machine cleaner.

Model	Amount of Cleaner
S0600C/S0680C/S0800C S1000C/S1200C	5 ounces (150 ml)
IB620C/IB680C/ IB820C/IB1020C	5 ounces (150 ml)
S1470C/S1870C/ S2070C/S2170C	9 ounces (270 ml)
S3070C/SF3000C	16 ounces (475 ml)

**Step 5** Wait until the clean cycle is complete (approximately \*35 minutes) then place the toggle switch in the OFF position and disconnect power to the ice machine (and dispenser when used).

NOTE: \*S3070C/SF3000C - 80 minutes.



### **Warning**

Disconnect the electric power to the ice machine at the electric service switch box.

**Step 6** Remove parts for cleaning.

**Please refer to the proper parts removal for your ice machine.**

**S600C/S680C/S850C/S1000C/S1200C - page 82**

**IB620C/IB680C/IB820C/IB1020C - page 85**

**S1470C/S1870C/S2170C - page 89**

**S3070C/SF3000C - page 92**

## **PARTS REMOVAL FOR CLEANING/SANITIZING**

### **S600C/S680C/S850C/S1000C/S1200C**

#### **A. Remove the water curtain**

- Gently flex the curtain in the center and remove it from the right side.
- Slide the left pin out.

#### **B. Remove the ice thickness probe**

- Compress the hinge pin on the top of the ice thickness probe.
- Pivot the ice thickness probe to disengage one pin then the other. The ice thickness probe can be cleaned at this point without complete removal. If complete removal is desired, disconnect the ice thickness control wiring from the control board.

#### **C. Remove the water distribution tube**

NOTE: Distribution tube thumbscrews are retained to prevent loss. Loosen thumbscrews but do not pull thumbscrews out of distribution tube.

- Loosen the two outer screws (do not remove screws completely they are retained to prevent loss) and pull forward on the distribution tube to release from slip joint.
- Disassemble distribution tube by loosening the two (2) middle thumbscrews and dividing the distribution tube into two pieces.

#### **D. Remove the water trough**

- Depress tabs on right and left side of the water trough.
- Allow front of water trough to drop as you pull forward to disengage the rear pins.

### **E. Remove the water level probe**

- Pull the water level probe straight down to disengage.
- Lower the water level probe until the wiring connector is visible.
- Disconnect the wire lead from the water level probe.
- Remove the water level probe from the ice machine.

### **F. Remove the water pump.**

- Grasp pump and pull straight down on pump assembly until water pump disengages and electrical connector is visible.
- Disconnect the electrical connector.
- Remove the water pump assembly from ice machine.
- Do not soak the water pump motor in cleaner or sanitizer solution.

### **G. Remove the evaporator tray or water diverter from the bottom of the evaporator.**

- Loosen thumbscrew on left side of tray.
- Allow left side of tray to drop as you pull the tray to the left side. Continue until the outlet tube disengages from the right side.

NOTE: Proceed to page 95, Step 7.

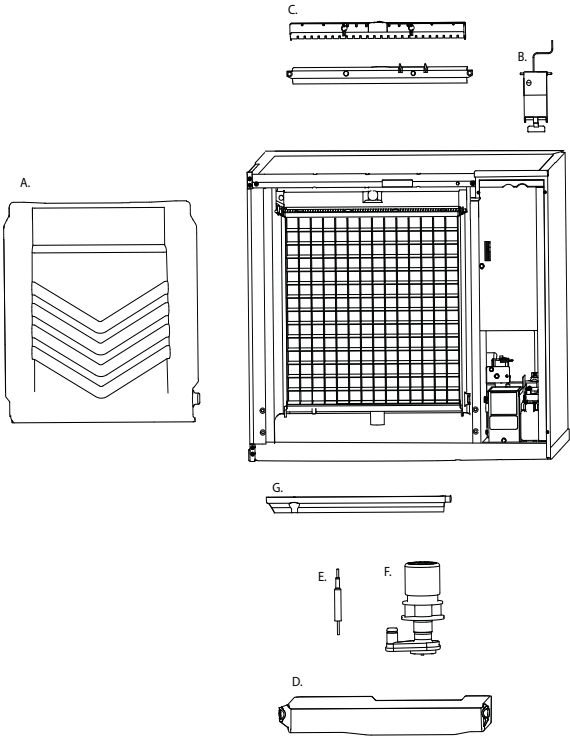

## **IB620C/IB680C/IB820C/IB1020C**

### **A. Remove the splash shield**

- Remove quarter turn connector from the right side of splash shield.
- Gently bow the center of the splash shield and lift up and forward to remove.

### **Important**

Splash Shield must be reinstalled to prevent water leakage.

### **B. Remove the water curtain**

- Gently flex the curtain in the center and remove it from the right side.
- Slide the left pin out.

### **C. Remove the ice thickness probe**

- Compress the hinge pin on the top of the ice thickness probe.
- Pivot the ice thickness probe to disengage one pin then the other. The ice thickness probe can be cleaned at this point without complete removal. If complete removal is desired, disconnect the ice thickness control wiring from the control board.

### **D. Remove the water level probe**

- Loosen the screw that holds the water level probe in place. The probe can easily be cleaned at this point without complete removal. If complete removal is desired, remove the top cover, left and right side panels and control box cover. Disconnect the wire lead from the control board inside the electrical control box.

## **E. Remove the water trough**

- Remove the quarter turn fasteners (turn counterclockwise) securing the trough in place.
- Pull forward on the water trough until the rear pins disengage from the water trough.
- Lift up and forward on the front of the water trough while allowing the rear of the water trough to drop.
- Remove the water trough from the ice machine.

## **F. Remove the water distribution tube**

- Remove the clamp from the vinyl water hose on the right side of the distribution tube.
- Loosen the two thumbscrews which secure the distribution tube.
- Lift the right side of the distribution tube up, and then rotate it backward and to the right until the left side of the distribution tube disengages the thumbscrew.

### **Caution**

Do not force this removal. The locating tab must be clear before rotating the distribution tube back.

- Pull the vinyl hose off the distribution tube.

Disassemble for cleaning:

- Twist both of the inner tube ends until the tabs line up with the keyways.
- Pull the inner tube ends outward.

### **G. Remove the water pump.**

- Note position of water pump outlet, and then disconnect vinyl hose from the pump outlet.
- Rotate the thumbscrew that secures the pump to the bulkhead 1/4 turn clockwise.
- Rotate the water pump assembly 1/4 turn counterclockwise.
- Lower the pump assembly into the evaporator compartment.
- Disconnect the water pump power cord.
- Remove water pump assembly from ice machine. Do not soak the water pump motor in cleaner or sanitizer solution

### **H. Remove the bin thermostat probe**

- Loosen the 2 screws that holds the probe in place. The probe can easily be cleaned at this point without complete removal.

NOTE: Proceed to page 95, Step 7.

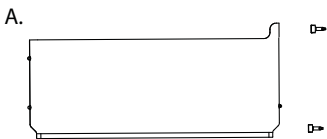
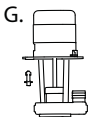
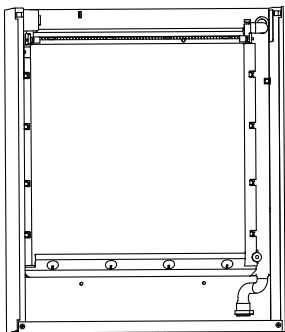
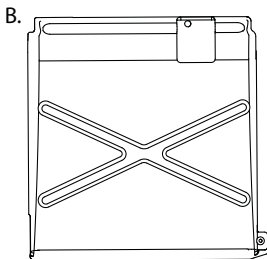
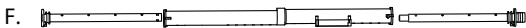

## **S1470C/S1870C/S2070C/S2170C**

### **A. Remove Splash Shields.**

- Grasp the top center of splash shields.
- Lift up and then out.

### **B. Remove ice thickness probe.**

- Compress the hinge pin on the top of the ice thickness probe.
- Pivot the ice thickness probe to disengage one pin then the other. The ice thickness probe can be cleaned at this point without complete removal. If complete removal is desired, disconnect the ice thickness control wiring from the control board.

### **C. Remove distribution tubes.**

- Distribution tubes thumbscrews are retained to prevent loss. Loosen thumbscrews but do not pull thumbscrews out of distribution tube.
- Loosen the two outer screws and pull forward on the distribution tube to release from slip joint.
- Disassemble distribution tube by loosening the two (2) middle thumbscrews and dividing the distribution tube into two pieces.

### **D. Remove the water trough shield.**

- Grasp the water trough shield in the center and the left end.
- Flex the water trough shield in the center and pull the left end forward until clear of the side wall. Repeat for the right end.
- Pull water trough shield forward to remove.

### **E. Remove ice dampers.**

- Grasp ice damper and apply pressure toward the back mounting bracket.
- Apply pressure to the front mounting bracket with thumb.
- Pull ice damper downward when the front ice damper pin disengages.

### **F. Remove the water pump assembly.**

- Disconnect the vinyl distribution tube from the water pump.
- Disconnect the water pump and water level probe electrical connections.
- After the wires are disconnected squeeze the two tabs and lift the water pump assembly out of the ice machine.
- Do not immerse the water pump motor in cleaner or sanitizer solutions.

### **G. Remove the water trough.**

- Depress the two tabs on the top of the water trough.
- Turn left and right ice dampers down to clear water trough.
- Pull forward on the water trough to remove.

NOTE: Proceed to page 95, Step 7.

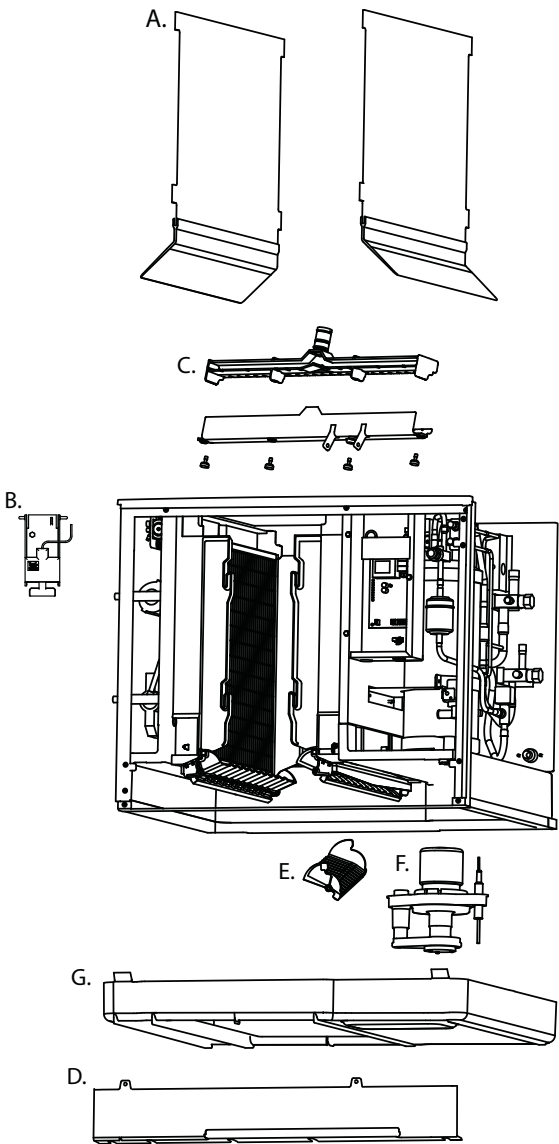

## **S3070C/SF3000C**

### **A.Remove front evaporator shield.**

- Remove four quarter turn connectors
- Remove splash shield

### **B.Remove left and right evaporator top covers.**

- Remove two thumbscrews from the front of each evaporator top cover.
- Lift front of cover, pull forward to remove.

### **C.Remove Splash Shields.**

NOTE: Each evaporator has a splash shield that must be removed - total of four splash shields.

- Grasp the top center of splash shields.
- Lift up and then out.

### **D. Remove ice thickness probe.**

- Compress the hinge pin on the top of the ice thickness probe.
- Pivot the ice thickness probe to disengage one pin then the other. The ice thickness probe can be cleaned at this point without complete removal. If complete removal is desired, disconnect the ice thickness control wiring from the control board.

## **E. Remove distribution tubes.**

NOTE: Each evaporator has a distribution that must be removed - total of four distribution tubes.

- Distribution tube thumbscrews are retained to prevent loss. Loosen thumbscrews but do not pull thumbscrews out of distribution tube.
- Loosen the two outer screws and pull forward on the distribution tube to release from slip joint.
- Disassemble distribution tube by loosening the two (2) middle thumbscrews and dividing the distribution tube into two pieces.

## **F. Remove ice dampers.**

NOTE: Each evaporator has an ice damper that must be removed - total of four ice dampers

- Grasp ice damper and apply pressure toward the back mounting bracket.
- Apply pressure to the front mounting bracket with thumb.
- Pull ice damper downward when the front ice damper pin disengages.

## **G. Remove the water pump assembly.**

- Disconnect the vinyl distribution tube from both water pumps.
- Disconnect the water pump and water level probe electrical connections.
- After the wires are disconnected remove the two thumbscrews and lift the water pump assembly out of the ice machine.
- Remove the thumbscrews securing the water pumps (2 each pump) and remove water pumps. Do not immerse the water pump motor in cleaner or sanitizer solutions.
- Remove the water level probe from the assembly housing.

## **H. Remove the water trough.**

- Pull forward on the water trough to remove.

NOTE: Proceed to page 95, Step 7.

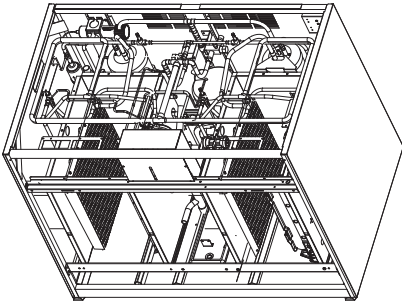

A

B

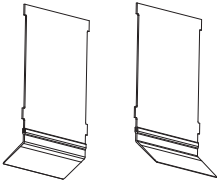
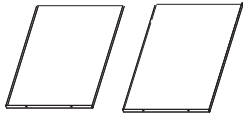
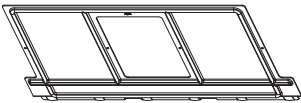

C

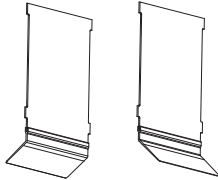

D



E

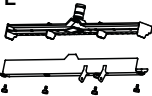

F



G

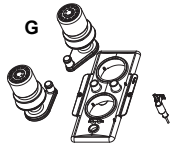

H

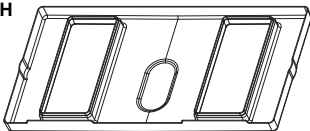

**Step 7** Mix a solution of cleaner and warm water. Depending upon the amount of mineral buildup, a larger quantity of solution may be required. Use the ratio in the table below to mix enough solution to thoroughly clean all parts.

<b>Solution Type</b>	<b>Water</b>	<b>Mixed With</b>
Cleaner	1 gal (4 l)	16 oz (500 ml) cleaner

**Step 8** Use 1/2 of the cleaner/water mixture to clean all components. The cleaner solution will foam when it contacts lime scale and mineral deposits; once the foaming stops use a soft-bristle nylon brush, sponge or cloth (NOT a wire brush) to carefully clean the parts. Soak parts for 5 minutes (15 - 20 minutes for heavily scaled parts). Rinse all components with clean water.

**Step 9** While components are soaking, use 1/2 of the cleaner/water solution to clean all food zone surfaces of the ice machine and bin (or dispenser). Use a nylon brush or cloth to thoroughly clean the following ice machine areas:

- Side walls
- Base (area above water trough)
- Evaporator plastic parts - including top, bottom, and sides
- Bin or dispenser

Rinse all areas thoroughly with clean water.

## SANITIZING PROCEDURE

**Step 10** Mix a solution of sanitizer and warm water.

Solution Type	Water	Mixed With
Sanitizer	6 gal. (23 l)	4 oz (120 ml) sanitizer

**Step 11** Use 1/2 of the sanitizer/water solution to sanitize all removed components. Use a cloth or sponge to liberally apply the solution to all surfaces of the removed parts or soak the removed parts in the sanitizer/water solution. Do not rinse parts after sanitizing.

**Step 12** Use 1/2 of the sanitizer/water solution to sanitize all food zone surfaces of the ice machine and bin (or dispenser). Use a cloth or sponge to liberally apply the solution. When sanitizing, pay particular attention to the following areas:

- Side walls
- Base (area above water trough)
- Evaporator plastic parts - including top, bottom and sides
- Bin or dispenser

Do not rinse the sanitized areas.

**Step 13** Replace all removed components.

**Step 14** Reapply power to the ice machine and place the toggle switch in the CLEAN position.

**Step 15** Wait about two minutes or until water starts to flow over the evaporator. Add the proper amount of Manitowoc Ice Machine Sanitizer to the water trough by pouring between the water curtain/splash shields and evaporator.

Model	Amount of Sanitizer
S0600C/S0680C/S0800C S1000C/S1200C	3 ounces (90 ml)
IB620C/IB680C/IB820C	3 ounces (90 ml)
IB1020C	3.5 ounces (104 ml)
S1470C/S1870C/ S2070C/S2170C	12 ounces (355 ml)
S3070C/SF3000C	25 ounces (740 ml)

**Step 16** The ice machine will stop after the sanitize cycle (approximately \*35 minutes). Place the toggle switch in the OFF position and disconnect power to the ice machine.

*\*S3070C/SF3000C - 80 minutes.*



### Warning

Disconnect the electric power to the ice machine at the electric service switch box.

**Step 17** Refer to step 6 and disassemble components. After disassembling proceed to step 18.

**Step 18** Mix a solution of sanitizer and warm water.

Solution Type	Water	Mixed With
Sanitizer	6 gal. (23 l)	4 oz (120 ml) sanitizer

**Step 19** Use 1/2 of the sanitizer/water solution to sanitize all removed components. Use a cloth or sponge to liberally apply the solution to all surfaces of the removed parts or soak the removed parts in the sanitizer/water solution. Do not rinse parts after sanitizing.

**Step 20** Use 1/2 of the sanitizer/water solution to sanitize all food zone surfaces of the ice machine and bin (or dispenser). Use a cloth or sponge to liberally apply the solution. When sanitizing, pay particular attention to the following areas:

- Side walls
- Base (area above water trough)
- Evaporator plastic parts - including top, bottom and sides
- Bin or dispenser

Do not rinse the sanitized areas.

**Step 21** Install the removed parts, restore power and place the toggle switch in the ICE position.

## **ADDITIONAL COMPONENT REMOVAL**

The following components may be removed for easier access in some installations or they may need to be removed and cleaned to correct an operational problem.

### **Water Dump Valve**

The water dump valve normally does not require removal for cleaning. To determine if removal is necessary:

1. Locate the water dump valve and follow the vinyl tubing to the drain.
2. Set the toggle switch to ICE and start a Freeze cycle.
3. Observe the drain outlet for leakage.
  - A. If the dump valve is leaking, replace the dump valve.
  - B. If the dump valve is not leaking, do not remove it. Instead, refer to cleaning and sanitizing procedure page 68.

## Water Inlet Valve

The water inlet valve normally does not require removal for cleaning. Follow the instructions below to determine if removal is necessary.

1. Set the ICE/OFF/CLEAN switch to OFF. Locate the water inlet (in the water area of the ice machine). It directs water into the water trough.
2. When the ice machine is off, the water inlet valve must completely stop water flow into the machine. Watch for water flow. If water flows, remove, disassemble and clean the valve.
3. When the ice machine is on, the water inlet valve must allow the proper water flow through it. Set the toggle switch to ON. Watch for water flow into the ice machine. If the water flow is slow or only trickles into the ice machine, remove, disassemble, and clean the valve.



### **Warning**

Disconnect the electric power to the ice machine at the electric service switch box and turn off the water supply before proceeding.

Follow the procedure below to remove the water inlet valve.

1. Remove the 1/4" hex head screws.
2. Remove, clean, and install the filter screen.

## Drain Line Check Valve

The drain line check valve (not used on all models) should be inspected and cleaned, whenever the ice machine is cleaned. Water loss from the sump trough will indicate removal and cleaning are required.

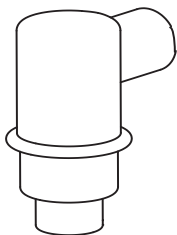

CHECK VALVE  
ASSEMBLY

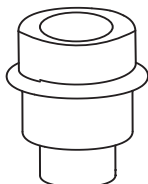

CHECK VALVE

SV3154

1. Remove check valve and tube assembly.
  - A. Tip assembly to right until tubing disengages.
  - B. Lift up on assembly to remove.
2. Remove insulation from check valve assembly.
3. Remove vinyl tubing from top of check valve.
4. Soak in cleaner solution 10 minutes, and then flush with water to remove debris.

## Evaporator Tray

1. Remove the water trough.
2. Directly below the evaporator, remove the thumbscrew on left side of tray.
3. Allow left side of tray to drop as you pull the tray to the left side. Continue until the outlet tube disengages from the right side.

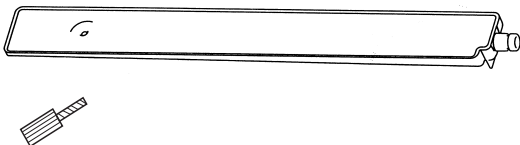

## Removal from Service/Winterization

### GENERAL

Special precautions must be taken if the ice machine is to be removed from service for an extended period of time or exposed to ambient temperatures of 32°F (0°C) or below.

#### **Caution**

If water is allowed to remain in the ice machine in freezing temperatures, severe damage to some components could result. Damage of this nature is not covered by the warranty.

1. Place the ice machine toggle switch in the OFF position.
2. Turn off the water supply.
3. Remove the water from the water trough.
4. Disconnect and drain the incoming ice-making water line at the rear of the ice machine.
5. Blow compressed air in the drain openings in the rear of the ice machine until no more water comes out of the drain.
6. Place the toggle switch in the ICE position, then wait 45 seconds for the water fill solenoid valve to energize. Blow compressed air through the incoming water supply in the rear of the ice machine until no more water comes out of the inlet water line.
7. Make sure water is not trapped in any of the water lines, drain lines, distribution tubes, etc.

## **CVD1486 WATER COOLED CONDENSING UNIT**

Place the ice machine toggle switch into the OFF position.

1. "Front seat" (shut off) the receiver service valve. Hang a tag on the switch as a reminder to open the valve before restarting.
2. Perform steps 1-6 on previous page.
3. Insert a large screwdriver between the bottom spring coils of the water regulating valve. Pry upward to open the valve.
4. Hold the valve open and blow compressed air through the condenser until no water remains.

**This Page Intentionally Left Blank**

# Sequence of Operation

---

**NOTE:** The toggle switch must be in the ice position and the water curtain/ice dampers must be in place on the evaporator before the ice machine will start.

## **INITIAL START-UP OR START-UP AFTER AUTOMATIC SHUT-OFF**

### **1. Water Purge**

Before the compressor starts, the water pump and water dump solenoid are energized to purge the ice machine of old water. This feature ensures that the ice making cycle starts with fresh water.

Single and twin evaporator models energize the harvest valve(s) and air compressor (when used) during the water purge and they remain energized during refrigeration start-up.

### **CVD Condensing Unit:**

When the refrigerant pressure is high enough to close the low-pressure control the contactor coil energizes and the compressor starts.

The compressor and fan cycling control\* are supplied with power throughout the entire Freeze and Harvest Sequences. When the refrigerant pressure is high enough to close the fan cycling pressure control the condenser fan motor starts.

### Energized Control Board Lights-

Single Evaporators = Left Bin (green)

Twin Evaporators = Left & Right Bin (green)

Quad Evaporators = All Curtain Switches (green),  
Dump Valve (red), Water Pump (red)

## 2. Refrigeration System Start-Up

**Ice Machine Head Section:** The liquid line solenoid valve and water inlet valve energize. Five seconds later single and twin evaporator models de-energize the harvest valve(s) and air compressor (when used).

### **CVD Condensing Unit:**

When the refrigerant pressure is high enough to close the low-pressure control the contactor coil energizes and the compressor starts.

The compressor and fan cycling control\* are supplied with power throughout the entire Freeze and Harvest Sequences. When the refrigerant pressure is high enough to close the fan cycling pressure control the condenser fan motor starts.

\*The IB0680C & S0680C ice machines do not use a fan cycling control. The compressor and the condenser fan motor are wired through the contactor. Any time the contactor coil is energized, these components are supplied with power.

### Energized Control Board Lights-

Single Evaporators = Left Bin (green)

Twin Evaporators = Left & Right Bin (green)

Quad Evaporators = All Curtain Switches (green),  
Water Solenoid (red), Liquid Solenoid (red)

## **FREEZE SEQUENCE**

### **3. Pre chill**

The compressor lowers the temperature of the evaporator(s) before the water pump(s) are energized. The water fill valve will remain energized until water contacts the water level probe.

#### Energized Control Board Lights-

Single Evaporators = Left Bin (green)

Twin Evaporators = Left & Right Bin (green)

Quad Evaporators = All Curtain Switches (green),  
Water Solenoid (red), Liquid Solenoid (red)

### **4. Freeze**

The water pump(s) energizes and water flows over the evaporator. After water contacts the water level probe the water fill valve de-energizes. The water fill valve may cycle on and then off one more time.

The freeze cycle continues until the six minute freeze lock expires and enough ice has formed to allow water to contact the ice thickness probe. After approximately 10 seconds of continual water contact, the harvest sequence is initiated.

NOTE: Freeze lock is bypassed after moving the toggle switch from OFF to ICE position for the first cycle only.

#### Energized Control Board Lights-

Single Evaporators = Left Bin (green), water probe (green), Ice Probe (green *when water contacts the ice thickness probe*)

Twin Evaporators = Left & Right Bin (green), water probe (green), Ice Probe (green *when water contacts the ice thickness probe*)

Twin Evaporators = Left & Right Bin (green),

Quad Evaporators = All Curtain Switches (green), Water Level (green), Water Solenoid (red), Liquid Solenoid (red), Water Pump (red), Harvest (red *when water contacts the ice thickness probe*)

## **HARVEST SEQUENCE**

### **5. Water Purge**

The air compressor (when used) and the harvest valve(s) open at the beginning of the water purge to divert hot refrigerant gas into the evaporator.

The water pump continues to run, and the water dump valve energizes to purge the water in the water trough.

Single and twin evaporator models energize the water fill valve for the last 15 seconds of the water purge cycle.

#### **CVD Condensing Unit:**

When the refrigerant pressure is low enough to open the fan cycling pressure control the condenser fan motor stops.

\* The IB0680C & S0680C ice machines do not use a fan cycle control, therefore the condenser fan motor will continue to run in the harvest cycle.

#### Energized Control Board Lights-

Single Evaporators = Left Bin (green), Harvest (red)

Twin Evaporators = Left & Right Bin (green), Harvest (red)

Quad Evaporators = All Curtain Switches (green), Liquid Solenoid (red), Dump Valve (red), Water Pump (red), Harvest (red), All Harvest Valves (red)

## 6. Harvest

The air compressor (when used) remains energized and the harvest valve(s) remains open. The refrigerant gas warms the evaporator causing the cubes to slide, as a sheet, off the evaporator and into the storage bin.

### Energized Control Board Lights-

Single Evaporators = Left Bin (green), Harvest (red)

Twin Evaporators = Left & Right Bin (green), Harvest (red)

Quad Evaporators = All Curtain Switches (green), Liquid Solenoid (red), Harvest (red), All Harvest Valves (red)

**Single evaporator models** - The sliding sheet of cubes opens the water curtain and bin switch.

The momentary opening and re-closing of the bin switch will terminate the harvest sequence and return to the freeze sequence (Step 3 - 4.)

**Twin & Quad evaporator models** - The sliding sheet of cubes opens the ice damper and bin switch. The momentary opening and re-closing of the bin switch de-energizes the harvest valve for the evaporator. When all of the bin switches have opened and closed the ice machine will terminate the harvest sequence and return to the freeze sequence (Step 3 - 4.)

### Energized Control Board Lights (once ice drops)-

Single Evaporators = Left Bin (green *flashes once*)

Twin Evaporators = Left & Right Bin (green *flashes once*)

Quad Evaporators = All Curtain Switches (green *flashes once*), Liquid Solenoid (red)

## ***Quad & Twin Evaporator Models Only***

### **6A. Water Assist Harvest Feature**

Typical duration of a Harvest sequence is less than 2.5 minutes. When the Harvest sequence time reaches 4 minutes, the following occurs:

4 minutes into a Harvest sequence: The water fill valve will energize to fill the trough with water until reaching the water level probe. 5 minutes into a Harvest sequence: The water pump will energize and flow water over the evaporators. The water fill valve remains on until water reaches the water level probe, the water pump remains on until all bin switches have been activated, or until the 7-minute Harvest sequence time limit is reached.

## **AUTOMATIC SHUT-OFF**

### **7. Automatic Shut-Off**

**Ice Machine Section:** Shuts off when:

- The storage bin is full at the end of a harvest sequence.
- The sheet of cubes fails to clear the water curtain and hold it open.
- Ice contacts the bin level thermostat probe (when used).
- Ice damper is held down.

After the water curtain or ice damper are held open for 30 seconds, the ice machine shuts off. The ice machine remains off for 3 minutes before it can automatically restart.

**CVD Condensing Unit:** The liquid line solenoid valve closes, allowing the refrigeration system to pump down. When the refrigerant pressure is low enough to open the fan cycling pressure control the condenser fan motor stops. When the refrigerant pressure is low enough to open the low pressure control, the contactor coil is de-energized and the compressor stops.

The ice machine remains off until enough ice has been removed from the storage bin to allow the ice to fall clear of the water curtain or ice damper. As the water curtain or ice damper swings back to the operating position, the bin switch re-closes and the ice machine restarts (steps 1 - 2), provided the 3 minute delay period is complete.

\* All CVD0675 and early production CVD0685 condensing units were manufactured without a fan cycle control and will not energize and de-energize the fan motor. Current production CVD0685 are manufactured with a fan cycle control.

#### Energized Control Board Lights-

Single Evaporators = No Lights

Twin Evaporators = Depending on which water curtain is open, the closed bin light will be lit (green)

Quad Evaporators = Depending on which damper is open, the closed dampers will be lit (green)



**Single & Twin Evaporator Energized Parts Chart (Continued)**

<b>Ice Making Sequence of Operation</b>	<b>Water Pump</b>	<b>Harvest Valve (s)</b>	<b>Air Pumps</b>	<b>Water Inlet Valve</b>	<b>Water Dump Valve</b>	<b>Liquid Line Solenoid Valve</b>	<b>Refrigeration Compressor &amp; Condenser Fan Motor</b>	<b>Length of Time</b>
<b>6. Harvest</b>	Off	On	On	Off	Off	On	On	Bin switch activation
<b>7. Automatic Shut-Off</b>	Off	Off	Off	Off	Off	Off	Off	Until all bin switches re-close & 3 min. delay expires



### Quad Evaporator Energized Parts Chart (Continued)

Ice Making Sequence of Operation	Water Pump	Harvest Valve (s)	Air Pumps	Water Inlet Valve	Water Dump Valve	Liquid Line Solenoid Valve	Refrigeration Compressor & Condenser Fan Motor	Length of Time
<b>6. Harvest</b>	Off	On	On	Off	Off	On	On	Bin switch activation
<b>7. Automatic Shut-Off</b>	Off	Off	Off	Off	Off	Off	Off	Until all bin switches re-close & 3 min. delay expires

## Safety Timers

The control board has the following non-adjustable safety timers:

- The ice machine is locked into the freeze cycle for 6 minutes before a harvest cycle can be initiated.
- The maximum freeze time is 60 minutes at which time the control board automatically initiates a harvest sequence (steps 5 & 6).
- The maximum harvest time is 3.5 minutes at which time the control board automatically ends the harvest cycle. When the bin switch is closed a freeze sequence initiates (steps 3 & 4). When the bin switch is open an automatic shutoff sequence initiates.
- The maximum water fill is 6 minutes.

## Water Assist Harvest Feature

### Twin & Quad Evaporators Only:

Typical duration of a Harvest sequence is less than 2.5 minutes. When the Harvest sequence time reaches 4 minutes, the following occurs:

4 minutes into a Harvest sequence: The water fill valve will energize to fill the trough with water.

5 minutes into a Harvest sequence: The water pump will energize and flow water over the evaporators.

The water fill valve and water pump remain on until all bin switches have been activated, or until the 7-minute Harvest sequence time limit is reached.

## Warm Water Rinse Cycle

### Single & Twin Evaporators Only:

Closing the back of the evaporator allows ice to build up on the rear of the evaporator and the plastic evaporator frame parts. After 200 freeze/harvest cycles have been complete the control board will initiate a warm water rinse.

After the 200th harvest cycle ends:

- The Clean and Harvest LED's energize to indicate the ice machine is in a warm water rinse.
- The compressor and harvest valve remain energized.
- The water pump energizes.
- The water inlet valve energizes until water contacts the water level probe.
- The compressor and harvest valve warm the water for 5 minutes, then de-energize.
- The water pump remains energized for an additional 5 minutes (10 minute total on time) then de-energizes.

The warm water rinse cycle can be terminated by moving the toggle switch to the OFF position, then back to ICE.

# Troubleshooting

---

## Safety Limits

In addition to standard safety controls, the control board has built in safety limit controls which protect the ice machine from major component failures.

Use the following procedures to determine if the control board contains a safety limit indication.

1. Move the toggle switch to OFF.
2. Move the toggle switch back to ICE.
3. Watch the safety limit lights/harvest light on the control board. If a safety limit has been recorded, the corresponding light will flash once, twice or three times to indicate which safety limit stopped the ice machine.

Safety limits are stored and indicated by the control board after three cycles. The number of cycles required to stop the ice machine varies for each safety limit.

- **Safety Limit 1 *all models*** - If the freeze time reaches 60 minutes, the control board automatically initiates a harvest cycle. If 6 consecutive 60-minute freeze cycles occur, the ice machine stops
- **Safety Limit 2 *single & twin evaporator models*** - If the harvest time reaches 3.5 minutes, the control board automatically returns the ice machine to the freeze cycle. If three 500 consecutive 3.5 minute harvest cycles occur, the ice machine stops.
- **Safety Limit 2 *quad evaporator models*** - If the harvest time reaches 7 minutes, the control board automatically returns the ice machine to the freeze cycle. If 500 consecutive 7 minute harvest cycles occur, the ice machine stops.
- **Safety Limit 3 *quad evaporator models*** - If the low refrigerant pressure control opens, the ice machine shuts off and starts a 5 minute delay period. If 3 consecutive low pressure events occur the ice machine stops and flashes the harvest light.

## ***Quad Evaporator Machines Only***

When a safety limit condition causes the ice machine to stop, the harvest light on the control board continually flashes on and off. Use the following procedures to determine which safety limit has stopped the ice machine.

1. Move the toggle switch to OFF.
2. Move the toggle switch back to ICE.
3. Watch the harvest light. It will flash one or two times, corresponding to safety limits 1 and 2, to indicate which safety limit stopped the ice machine.

After safety limit indication, the ice machine will restart and run until a safety limit is exceeded again.

When a safety limit condition is exceeded for 3 consecutive cycles the control board enters the limit to memory and the ice machine continues to run. Use the following procedure to determine if the control board contains a safety limit indication.

1. Move the toggle switch to OFF.
2. Move the toggle switch back to ICE.
3. Watch the harvest light. It will flash one or two times, corresponding to safety limits 1 and 2, to indicate which safety limit stopped the ice machine.

When a safety limit condition is exceeded (6 consecutive cycles for safety limit #1 or 500 cycles for safety limit #2) the ice machine stops, and the harvest light on the control board flashes on and off. Use the following procedure to determine which safety limit has stopped the ice machine.

1. Move the toggle switch to OFF.
2. Move the toggle switch back to ICE.
3. Watch the harvest light. It will flash one or two times, corresponding to safety limits 1 and 2, to indicate which safety limit stopped the ice machine.

After safety limit indication, the ice machine will restart and run until a safety limit is exceeded again.

## **SAFETY LIMIT ANALYSIS**

According to the refrigeration industry, a high percentage of compressors fail as a result of external causes. These can include: flooding or starving expansion valves, dirty condensers, water loss to the ice machine, etc. The safety limits protect the ice machine (primarily the compressor) from external failures by stopping ice machine operation before major component damage occurs.

The safety limit system is similar to a high pressure cut-out control. It stops the ice machine, but does not tell what is wrong. The service technician must analyze the system to determine what caused the high pressure cut-out, or a particular safety limit, to stop the ice machine.

The safety limits are designed to stop the ice machine prior to major component failures, most often a minor problem or something external to the ice machine. This may be difficult to diagnose, as many external problems occur intermittently.

Example: An ice machine stops intermittently on safety limit #1 (long freeze times). The problem could be a low ambient temperature at night, a water pressure drop, the water is turned off one night a week, etc.

Refrigeration and electrical component failures will cause a safety limit trip. Eliminate all electrical components and external causes first. If it appears that the refrigeration system is causing the problem, use Manitowoc's Freeze Cycle Refrigeration System Operational Analysis Table, along with detailed charts, checklists, and other references to determine the cause.

The following checklists are designed to assist the service technician in analysis. However, because there are many possible external problems, do not limit your diagnosis to only the items listed.

## **SAFETY LIMIT#1**

Freeze time exceeds 60 minutes for 6 consecutive freeze cycles

### *Possible Cause Checklist*

#### **Improper Installation**

- Refer to "Installation/Visual Inspection Checklist" page 145.

#### **Water System**

- Dirty/defective water level probe
- Low water pressure (20 psig min.)
- High water pressure (80 psig max.)
- High water temperature (90°F/32.2°C max.)
- Clogged water distribution tube
- Dirty/defective water fill valve
- Dirty/defective water dump valve
- Defective water pump
- Loss of water from sump area

#### **Electrical System**

- Low incoming voltage
- Ice thickness probe out of adjustment
- Harvest cycle not initiated electrically
- Contactor not energizing
- Compressor electrically non-operational
- Defective fan cycling control
- Defective fan motor

#### **Miscellaneous**

- Non-Manitowoc components
- Improper refrigerant charge
- Defective head pressure control
- Defective harvest valve
- Defective compressor
- TXV starving or flooding (check bulb mounting)
- Non-condensable in refrigeration system
- Plugged or restricted high side refrigerant lines or component
- Restricted air flow/dirty condenser fins
- High inlet air temperature
- Condenser discharge air recirculation

## **SAFETY LIMIT #2**

Single & Twin Models - Harvest time exceeds 3.5 minutes for 500 consecutive harvest cycles

Quad Models - Harvest time exceeds 7 minutes for 500 consecutive harvest cycles

### *Possible Cause Checklist*

#### ***Improper Installation***

- Refer to "Installation/Visual Inspection Checklist" page 145

#### ***Water System***

- Water area (evaporator) dirty
- Dirty/defective water dump valve
- Vent tube not installed on water outlet drain
- Water freezing behind evaporator
- Plastic extrusions and gaskets not securely mounted to the evaporator
- Low water pressure (20 psig min.)
- Loss of water from sump area
- Clogged water distribution tube
- Dirty/defective water fill valve
- Defective water pump

#### ***Electrical System***

- Ice thickness probe out of adjustment
- Ice thickness probe dirty
- Bin switch closed/defective
- Premature harvest

#### ***Refrigeration System***

- Non-Manitowoc components
- Improper refrigerant charge
- Defective head pressure control valve
- Defective harvest valve
- TXV flooding (check bulb mounting)
- Defective fan cycling control
- CVD1486 Only - Water inlet valve is incorrectly adjusted or will not close during harvest cycle.

## **SAFETY LIMIT #3**

### **Water System**

- Water supply to machine is being interrupted
- Water leaking down the drain during freeze (dump valve)
- Water tracking into bin
- Uneven water flow over evaporator
- Water pump not pumping

### **Electrical System**

- Water level probe prematurely satisfied
- Water inlet valve failure
- Water pump failure

### **Refrigeration System**

- Low on Refrigerant
- Starving TXV

## Control Board Testing

All replacement S Model control boards and ice machines with serial numbers larger than 110924847 have a control board that includes a diagnostic test cycle. The control board can be identified by the blue printed circuit board and a push button switch on the bottom left corner labeled "service mode".

### CONTROL BOARD TEST CYCLE

1. Place the toggle switch in the ice position.
2. Press and hold the test button for 5 seconds.
3. The control board memory is cleared.
  - A. All safety limits are cleared
  - B. Resets to factory default settings
  - C. Calibration is cleared for ice thickness & water level probe.
4. The control board relays close at 1 second intervals and energize the corresponding control board light.
5. The relays remain closed and the lights remain energized for 3.5 minutes to allow time to test voltage at components.
6. After 3.5 minutes the ice machine automatically exits the test cycle.
7. An ice making cycle will automatically start (unless the toggle switch is moved to OFF).
8. Water level and ice thickness probe calibration are processed and stored in control board memory during the second ice making cycle.

NOTE: The test cycle can be terminated at anytime by moving the toggle switch from ICE to OFF, or by disconnecting and reapplying line voltage to the ice machine.

## **Troubleshooting By Symptom**

The troubleshooting procedures follow flow charts. There are four symptoms, the symptom that you are experiencing will determine which flow chart to use. The flow chart asks yes and no questions to determine the problem. The flow chart will direct you to a procedure to correct the problem.

### **Symptom #1**

**Ice Machine Stops Running**

**Toggle Switch is in the ICE position**

**or**

**Has a History of Shutting Down**

- Refer to Ice Machine Stops Running Flow Chart (page 125)

### **Symptom #2**

**Ice Machine has a Long Freeze Cycle.**

**Ice Formation is Thick**

**or**

**Thin Ice Fill on Top or Bottom of Evaporator**

**or**

**Low Production**

Safety Limit #1 (possible)

- Refer to Freeze Cycle Refrigeration System Operational Analysis Table (page 132)

### **Symptom #3**

**Ice Machine Will Not Harvest - Freeze Cycle is Normal and Ice Cubes are Not Melted After Harvest**

Safety Limit #2 (possible)

- Refer to Refrigeration Harvest Flow Chart (page 159)

### **Symptom #4**

**Ice Machine Will Not Harvest - Freeze Cycle is Normal and Ice Cubes are Melted After Harvest**

- Refer to Ice Melt out Flow Chart (page 166)

## Symptom #1 Ice Machine Will Not Run

Ice Machine stops running or has history of shutting down

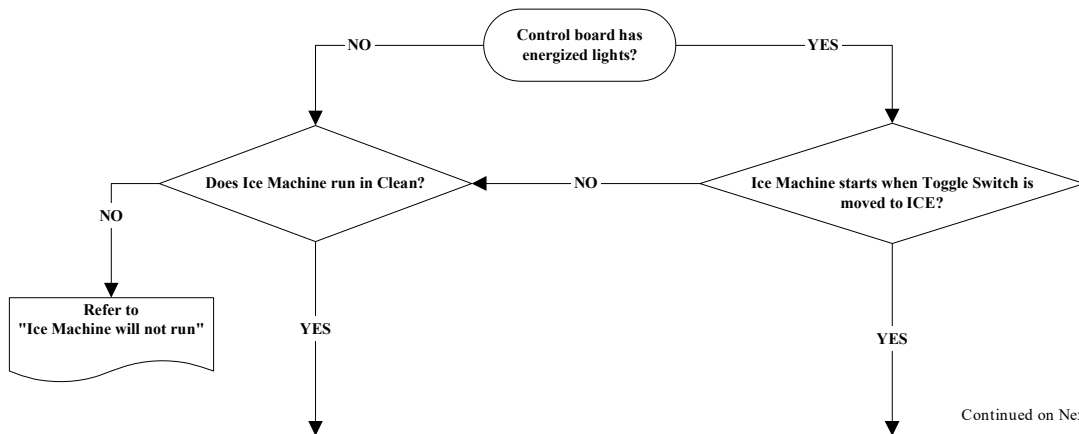

Continued on Next Page...

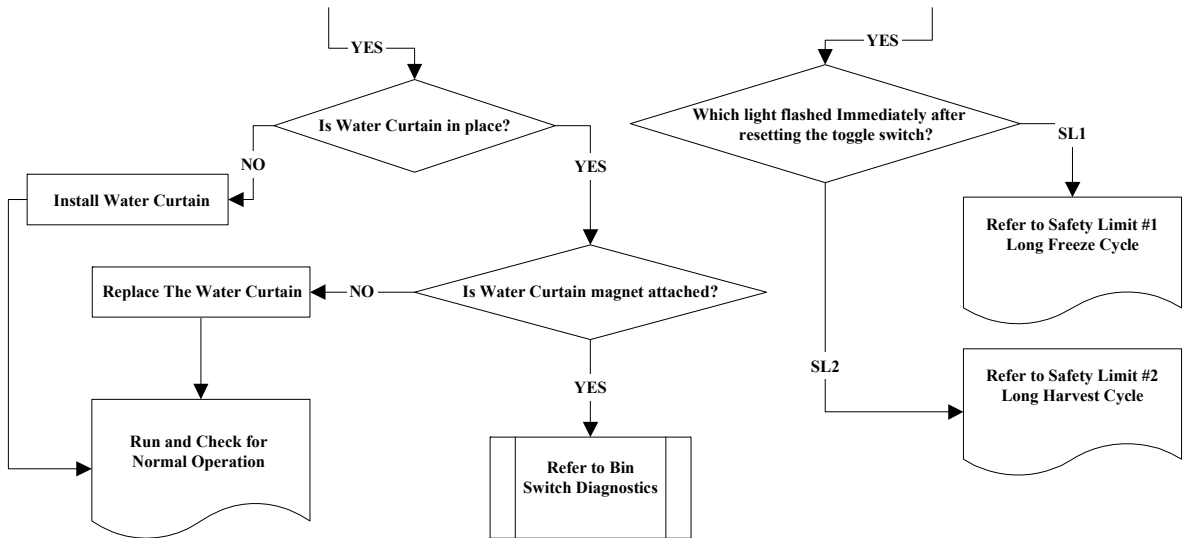

## DIAGNOSING AN ICE MACHINE HEAD SECTION THAT WILL NOT RUN

### **Warning**

High (line) voltage is applied to the control board (terminals #55 and #56) at all times. Removing control board fuse or moving the toggle switch to OFF will not remove the power supplied to the control board.

1. Verify primary voltage is supplied to ice machine and the fuse/circuit breaker is closed.
2. Verify control board fuse is okay. If the bin switch or water level probe light functions, the fuse is okay.
3. Verify all bin switches function properly. A defective bin switch can falsely indicate a full bin of ice.
4. Verify ICE/OFF/CLEAN toggle switch functions properly. A defective toggle switch may keep the ice machine in the OFF mode.
5. Verify low DC voltage is properly grounded. Loose DC wire connections may intermittently stop the ice machine.
6. Replace the control board. Be sure steps 1-6 were followed thoroughly. Intermittent problems are not usually related to the control board.

## **DIAGNOSING A CONDENSING UNIT THAT WILL NOT RUN**

If the ice machine water pump is not energized, refer to “Diagnosing an Ice Machine Head Section that Will Not Run page 127.”

1. Verify primary voltage is supplied to ice machine condensing unit and the fuse/circuit breaker is closed.
2. Verify the high-pressure cutout and low-pressure cutouts are closed. The HPCO and LPCO are closed if primary line voltage is present at the contactor coil terminals.
3. Verify line voltage is present at the contactor coil.
4. Verify the contactor contacts are closed and line voltage is present across all lines.
5. Refer to compressor diagnostics page 129.

## **COMPRESSOR ELECTRICAL DIAGNOSTICS**

The compressor does not start or will trip repeatedly on overload.

### Check Resistance (Ohm) Values

NOTE: Compressor windings can have very low ohm values. Use a properly calibrated meter.

Perform the resistance test after the compressor cools. The compressor dome should be cool enough to touch (below 120°F/49°C) to assure that the overload is closed and the resistance readings will be accurate.

### Single Phase Compressors

1. Disconnect power then remove the wires from the compressor terminals.
2. The resistance values between C and S and between C and R, when added together, should equal the resistance value between S and R.
3. If the overload is open, there will be a resistance reading between S and R, and open readings between C and S and between C and R. Allow the compressor to cool, then check the readings again.

### Three Phase Compressors

1. Disconnect power and remove the wires from the compressor terminals.
2. The resistance values between L1 and L2, between L2 and L3, and between L3 and L1 should all be equal.
3. If the overload is open, there will be open readings between L1 and L2, between L2 and L3, and between L3 and L1. Allow the compressor to cool, then check the readings again.

### Check Motor Windings to Ground

Check continuity between all three terminals and the compressor shell or copper refrigeration line. Scrape metal surface to get good contact. If continuity is present, the compressor windings are grounded and the compressor should be replaced.

### Compressor Drawing Locked Rotor

To determine if the compressor is seized, check the amp draw while the compressor is trying to start.

The two likely causes of this are a defective starting component and a mechanically seized compressor.

To determine which you have:

- Install high and low side gauge set.
- Try to start the compressor.
- Watch the pressures closely.
- If the pressures do not move, the compressor is seized. Replace the compressor.

If the pressures move, the compressor is turning slowly and is not seized. Check the capacitors and relay.

### Compressor Drawing High Amps

The continuous amperage draw on start-up should not be near the maximum fuse size indicated on the serial tag.

The wiring must be correctly sized to minimize voltage drop at compressor start-up. The voltage when the compressor is trying to start must be within  $\pm 10\%$  of the nameplate voltage.

## DIAGNOSING CAPACITORS

- If the compressor attempts to start, or hums and trips the overload protector, check the starting components before replacing the compressor.
- Visual evidence of capacitor failure can include a bulged terminal end or a ruptured membrane. Do not assume a capacitor is good if no visual evidence is present.
- A good test is to install a known good substitute capacitor.
- Use a capacitor tester when checking a suspect capacitor. Clip the bleed resistor off the capacitor terminals before testing.

## **Symptom #2 Low Production, Long Freeze Cycle**

**Ice Machine has a Long Freeze Cycle.**

**Ice Formation is Thick**

**or**

**Thin Ice Fill on Top or Bottom of Evaporator**

**or**

**Low Production**

**How to Use the Freeze Cycle**

**Refrigeration System Operational**

**Analysis Table**

### GENERAL

These tables must be used with charts, checklists and other references to eliminate refrigeration components not listed on the tables and external items and problems which can cause good refrigeration components to appear defective.

The tables list five different defects that may affect the ice machine's operation.

NOTE: A low-on-charge ice machine and a starving expansion valve have very similar characteristics and are listed under the same column.

NOTE: Before starting, see "Before Beginning Service" page 143 for a few questions to ask when talking to the ice machine owner.

## PROCEDURE

### **Step 1 Complete the “Operational Analysis” column.**

Read down the left “Operational Analysis” column. Perform all procedures and check all information listed. Each item in this column has supporting reference material to help analyze each step.

While analyzing each item separately, you may find an “external problem” causing a good refrigerant component to appear bad. Correct problems as they are found. If the operational problem is found, it is not necessary to complete the remaining procedures.

### **Step 2 Enter check marks (✓).**

Each time the actual findings of an item in the “Operational Analysis” column matches the published findings on the table, enter a check mark.

Example: Freeze cycle suction pressure is determined to be low. Enter a check mark in the “low” column.

### **Step 3 Add the check marks listed under each of the four columns. Note the column number with the highest total and proceed to “Final Analysis.”**

**NOTE:** If two columns have matching high numbers, a procedure was not performed properly, supporting material was not analyzed correctly or the problem component is not covered by the analysis table.

## SYMPTOM #2 - REFRIGERATION SYSTEM OPERATIONAL ANALYSIS TABLES

### S QuietQube Models Single Expansion Valve

Operational Analysis	1	2	3	4
<b>Ice Production</b>	Published 24 hour ice production _____ Calculated (actual) ice production _____ NOTE: The ice machine is operating properly if the ice fill patterns is normal and ice production is within 10% of charted capacity.			
<b>Installation and Water System</b>	All installation and water related problems must be corrected before proceeding with chart.			
<b>Ice Formation Pattern</b>	Ice formation is extremely thin on outlet of evaporator -or- No ice formation on the entire evaporator	Ice formation normal -or- Ice formation is extremely thin on outlet of evaporator -or- No ice formation on entire evaporator	Ice formation normal -or- Ice formation is extremely thin on inlet of evaporator -or- No ice formation on entire evaporator	Ice formation normal -or- No ice formation on entire evaporator

### S QuietQube Models Single Expansion Valve

Operational Analysis	1	2	3	4
<b>Safety Limits</b> Refer to “Analyzing Safety Limits” page 119 to eliminate all non-refrigeration problems.	Stops on safety limit: <b>1 or 2</b>	Stops on safety limit: <b>1 or 2</b>	Stops on safety limit: <b>1 or 2</b>	Stops on safety limit: <b>1</b>
<b>Freeze Cycle Discharge Pressure</b> <u>          </u> <u>          </u> <u>          </u> <b>1 minute Middle End</b> <b>into cycle</b>	If discharge pressure is High or Low refer to freeze cycle high or low discharge pressure problem checklist page 151 & page 152 to eliminate problems and/or components not listed on this table before proceeding.			
<b>Freeze Cycle Suction Pressure</b> <u>          </u> <u>          </u> <u>          </u> <b>1 minute Middle End</b>	If suction pressure is High or Low refer to freeze cycle high or low suction pressure problem checklist page 154 & page 155 to eliminate problems and/or components not listed on this table before proceeding.			
	Suction pressure is <b>High</b>	Suction pressure is <b>Low or Normal</b>	Suction pressure is <b>Normal or High</b>	Suction pressure is <b>High</b>
<b>Harvest Valve</b>	Audible refrigerant flow through left or right valve in Freeze cycle	No audible refrigerant flow through left or right valve in Freeze cycle	No audible refrigerant flow through left or right valve in Freeze cycle	No audible refrigerant flow through left or right valve in Freeze cycle

### S QuietQube Models Single Expansion Valve

Operational Analysis	1	2	3	4
<p><b>Suction Line Temperature</b> Attach a temperature probe on the suction line with-in 6" of the shut-off valve outlet. Record the low event at the end of the freeze cycle</p>	<p>Suction line temp. at the suction shut-off valve is <b>greater than 10°F (-12.2°C)</b> at the end of the freeze cycle</p>	<p>Suction line temp. at the suction shut-off valve is <b>greater than 10°F (-12.2°C)</b> at the end of the freeze cycle</p>	<p>Suction line temp. at the suction shut-off valve is <b>less than 10°F (-12.2°C)</b> at the end of the freeze cycle</p>	<p>Suction line temp. at the suction shut-off valve is <b>greater than 10°F (-12.2°C)</b> at the end of the freeze cycle</p>
<p><b>Final Analysis</b> Enter total number of boxes checked in each column.</p>	<p><b>Harvest Valve Leaking</b></p>	<p><b>Low On Charge -Or- TXV Starving</b></p>	<p><b>Refrigerant Overcharge -Or- TXV Flooding</b></p>	<p><b>Compressor</b></p>

### Twin Expansion Valve – S1470C/S1870C/S2070C/S2170C

Operational Analysis	1	2	3	4
<b>Ice Production</b>	Published 24-hour ice production _____ Calculated (actual) 24-hour ice production _____ <b>NOTE:</b> The ice machine is operating properly if the ice fill pattern is normal and ice production is within 10% of charted capacity.			
<b>Installation and Water System</b>	All installation and water-related problems must be corrected before proceeding with chart.			
<b>Ice Formation Pattern</b>  <b>Left</b> _____  <b>Right</b> _____	Ice formation is extremely thin on outlet of one evaporator -or- No ice formation on top of one evaporator	Ice formation is normal -or- Ice formation is extremely thin on outlet of one or both evaporators -or- No ice formation on one or both evaporators	Ice formation is normal -or- Ice formation is extremely thin on the inlet of one evaporator -or- No ice formation on one evaporator	Ice formation is normal -or- No ice formation on both evaporators

## Twin Expansion Valve – S1470C/S1870C/S2070C/S2170C

<b>Operational Analysis</b>	<b>1</b>	<b>2</b>	<b>3</b>	<b>4</b>
<b>Safety Limits</b> Refer to “Analyzing Safety Limits” page 119 to eliminate all non-refrigeration problems.	Stops on <b>safety limit:</b> <b>1 or 2</b>	Stops on <b>safety limit:</b> <b>1 or 2</b>	Stops on <b>safety limit:</b> <b>1 or 2</b>	Stops on <b>safety limit:</b> <b>1</b>
<b>Freeze Cycle Discharge Pressure</b>  <div style="display: flex; justify-content: space-between; width: 80%; margin: 0 auto;"> <span>_____</span> <span>_____</span> <span>_____</span> </div> <div style="display: flex; justify-content: space-between; width: 80%; margin: 0 auto;"> <span>1 minute</span> <span>Middle</span> <span>End</span> </div>	If discharge pressure is High or Low, refer to Freeze cycle high or low discharge pressure problem checklist page 151 & page 152 to eliminate problems and/or components not listed on this table before proceeding.			
<b>Freeze Cycle Suction Pressure</b>  <div style="display: flex; justify-content: space-between; width: 80%; margin: 0 auto;"> <span>_____</span> <span>_____</span> <span>_____</span> </div> <div style="display: flex; justify-content: space-between; width: 80%; margin: 0 auto;"> <span>1 minute</span> <span>Middle</span> <span>End</span> </div>	If suction pressure is High or Low, refer to Freeze cycle high or low suction pressure problem checklist page 154 & page 155 to eliminate problems and/or components not listed on this table before proceeding.			
	Suction pressure is High	Suction pressure is Low or Normal	Suction pressure is High or Normal	Suction pressure is High

### Twin Expansion Valve – S1470C/S1870C/S2070C/S2170C

Operational Analysis	1	2	3	4
<b>Harvest Valve</b>	Audible refrigerant flow through left or right valve in Freeze cycle	No audible refrigerant flow through left or right valve in Freeze cycle	No audible refrigerant flow through left or right valve in Freeze cycle	No audible refrigerant flow through left or right valve in Freeze cycle
<b>Suction Line Temperature</b> Attach a temperature probe on the suction line within 6 in. of the shut-off valve outlet. Record the low event at the end of the Freeze cycle.	Suction line temperature at the suction shut-off valve is <b>greater than 10°F (-12.2°C)</b> at the end of the Freeze cycle	Suction line temperature at the suction shut-off valve is <b>greater than 10°F (-12.2°C)</b> at the end of the Freeze cycle	Suction line temperature at the suction shut-off valve is <b>less than 10°F (-12.2°C)</b> at the end of the Freeze cycle	Suction line temperature at the suction shut-off valve is <b>greater than 10°F (-12.2°C)</b> at the end of the Freeze cycle
<b>Final Analysis</b> Enter total number of boxes checked in each column.	Harvest Valve Leaking	Low on charge -or- TXV starving	Refrigerant Overcharge -or- TXV flooding	Compressor

### Quad Expansion Valve – S3070C/SF3000C

Operational Analysis	1	2	3	4
<b>Ice Production</b>	Air-Temperature Entering Condenser _____ Water Temperature Entering Ice Machine _____ Published 24 hour ice production _____ Calculated (actual) ice production _____ NOTE: The ice machine is operating properly if the ice fill patterns is normal and ice production is within 10% of charted capacity.			
<b>Installation and Water System</b>	All installation and water related problems must be corrected before proceeding with chart.			
<b>Ice Formation Pattern</b> Evaporators are numbered left to right viewed from the front of the ice machine Evaporator #1 _____ Evaporator #2 _____ Evaporator #3 _____ Evaporator #4 _____	Ice formation is normal	Ice formation is extremely thin on outlet of 1 or more evaporators -or- No ice formation on entire evaporator	Ice formation normal	Ice formation normal or No ice formation on entire evaporator

### Quad Expansion Valve – S3070C/SF3000C

Operational Analysis	1	2	3	4
<b>Safety Limits</b> Refer to “Analyzing Safety Limits” page 119 to eliminate all non refrigeration problems	Stops on Safety Limit: <b>2</b>	Stops on Safety Limit: <b>1 or 2</b>	Stops on Safety Limit: <b>2</b>	Stops on Safety Limit: <b>1</b>
<b>Freeze Cycle Discharge Pressure</b> _____ _____ Middle _____ 1 minute      End	If discharge pressure is High or Low refer to freeze cycle high or low discharge pressure problem checklist page 151 & page 152 to eliminate problems and/or components not listed on this table before proceeding.			
<b>Freeze Cycle Suction Pressure</b> _____ _____ Middle _____ 1 minute      End	If suction pressure is High or Low refer to freeze cycle high or low suction pressure problem checklist page 154 & page 155 to eliminate problems and/or components not listed on this table before proceeding.			
	Suction pressure is <b>Normal or High</b>	Suction pressure is <b>Low or Normal</b>	Suction pressure is <b>Normal or High</b>	Suction pressure is <b>High</b>

### Quad Expansion Valve – S3070C/SF3000C

Operational Analysis	1	2	3	4
<p><b>Evaporator Outlet Temperature Comparison</b> Attach and insulate temperature probes between evaporator outlet and 90° elbow</p>	<p>Evaporator outlet temperatures are <b>within 10°F of each other</b></p>	<p>Evaporator outlet temperatures are <b>NOT within 10°F of each other</b> or <b>Within 10°F of each other and above 32°F</b></p>	<p>Evaporator outlet temperatures are <b>NOT within 10°F of each other</b></p>	<p>Evaporator outlet temperatures are <b>within 10°F of each other</b></p>
<p><b>Harvest Valve</b> A leaking harvest valve gives an audible indication before ice fill pattern or machine performance is affected</p>	<p><b>Audible flow</b> of refrigerant through any harvest valve during the freeze cycle</p>	<p><b>No Audible flow</b> of refrigerant through any harvest valve during the freeze cycle</p>	<p><b>No Audible flow</b> of refrigerant through any harvest valve during the freeze cycle</p>	<p><b>No Audible flow</b> of refrigerant through any harvest valve during the freeze cycle</p>
<p><b>Final Analysis</b> Enter total number of boxes checked in each column.</p>	<p><b>Harvest Valve Leaking</b></p>	<p><b>Low On Charge -Or- TXV Starving</b></p>	<p><b>Refrigerant Overcharge or TXV Flooding</b></p>	<p><b>Compressor</b></p>

## **SYMPTOM #2 - FREEZE CYCLE REFRIGERATION SYSTEM OPERATIONAL ANALYSIS TABLE PROCEDURES**

The following is the procedures for completing each step of the Symptom #2 - Freeze Cycle Refrigeration System Operational Analysis Tables. Each procedure must be performed exactly for the table to work correctly.

### **Before Beginning Service**

Ice machines may experience operational problems only during certain times of the day or night. A machine may function properly while it is being serviced, but malfunctions later. Information provided by the user can help the technician start in the right direction, and may be a determining factor in the final diagnosis.

Ask these questions before beginning service:

- When does the ice machine malfunction? (night, day, all the time, only during the Freeze cycle, etc.)
- When do you notice low ice production? (one day a week, every day, on weekends, etc.)
- Can you describe exactly what the ice machine seems to be doing?
- Has anyone been working on the ice machine?
- During “store shutdown,” is the circuit breaker, water supply or air temperature altered?
- Is there any reason why incoming water pressure might rise or drop substantially?

## Ice Production Check

The amount of ice a machine produces directly relates to the operating water and air temperatures. This means a condensing unit with a 70°F (21.2°C) outdoor ambient temperature and 50°F (10.0°C) water produces more ice than the same model condensing unit with a 90°F (32.2°C) outdoor ambient temperature and 70°F (21.2°C) water.

1. Determine the ice machine operating conditions:  
Air temp entering condenser: \_\_\_\_\_°  
Air temp around ice machine: \_\_\_\_\_°  
Water temp entering sump trough: \_\_\_\_\_°
  2. Refer to the appropriate 24-Hour Ice Production Chart. Use the operating conditions determined in step 1 to find published 24-hour ice production: \_\_\_\_\_
- Times are in minutes.  
Example: 1 min. 15 sec. converts to 1.25 min.  
(15 seconds ÷ 60 seconds = .25 minutes)
  - Weights are in pounds.  
Example: 2 lb. 6 oz. converts to 2.375 lb.  
(6 oz. ÷ 16 oz. = .375 lb.)
3. Perform an ice production check using the formula below.

1.	$\frac{\text{Freeze Time}}{\text{}} + \frac{\text{Harvest Time}}{\text{}} = \frac{\text{Total Cycle Time}}{\text{}}$
2.	$\frac{1440}{\text{Minutes in 24 Hrs.}} \div \frac{\text{Total Cycle Time}}{\text{}} = \frac{\text{Cycles per Day}}{\text{}}$
3.	$\frac{\text{Weight of One Harvest}}{\text{}} \times \frac{\text{Cycles per Day}}{\text{}} = \frac{\text{Actual 24-Hour Production}}{\text{}}$

Weighing the ice is the only 100% accurate check. However, if the ice pattern is normal and the 1/8 in. thickness is maintained, the ice slab weights listed with the 24-Hour Ice Production Charts may be used.

4. Compare the results of step 3 with step 2. Ice production is normal when these numbers match closely. If they match closely, determine if:
- Another ice machine is required.
  - More storage capacity is required.
  - Relocating the existing equipment to lower the load conditions is required.

## **Installation/Visual Inspection Checklist**

### ***Inadequate Clearances***

- Check all clearances on sides, back and top.

### ***Ice machine is not level***

- Level the ice machine

### ***Condenser is dirty***

- Clean the condenser

### ***Water filtration is plugged (if used)***

- Install a new water filter

### ***Water drains are not run separately and/or are not vented***

- Run and vent drains according to the Installation Manual

### ***Line set is improperly installed***

- Reinstall according to the Installation Manual

## **Water System Checklist**

A water-related problem often causes the same symptoms as a refrigeration system component malfunction.

Water system problems must be identified and eliminated prior to replacing refrigeration components.

### ***Water area (evaporator) is dirty***

- Clean as needed

### ***Water inlet pressure not between 20 and 80 psig (1-5 Bar, 138-552 kPa).***

- Install water regulator valve or increase water pressure

### ***Incoming water temperature is not between 40°F (4.4°C) and 90°F (32.2°C)***

- If too hot, check the hot water line check valves in other store equipment

### ***Water filtration is plugged (if used)***

- Install a new water filter

### ***Water dump valve leaking during the Freeze cycle***

- Clean/replace dump valve as needed

### ***Vent tube is not installed on water outlet drain***

- See Installation Instructions

### ***Hoses, fittings, etc., are leaking water***

- Repair/replace as needed

### ***Water fill valve or float is stuck open or closed***

- Clean/replace as needed

### ***Water is spraying out of the sump trough area***

- Stop the water spray

### ***Uneven water flow across the evaporator***

- Clean the ice machine

### ***Water is freezing behind the evaporator***

- Correct the water flow

### ***Plastic extrusions and gaskets are not secured to the evaporator***

- Remount/replace as needed

## Ice Formation Pattern

Evaporator ice formation pattern analysis is helpful in ice machine diagnostics.

Analyzing the ice formation pattern alone cannot diagnose an ice machine malfunction. However, when this analysis is used along with Manitowoc's Symptom #2 - Refrigeration System Operational Analysis Table, it can help diagnose an ice machine malfunction.

Any number of problems can cause improper ice formation.

### Important

Keep the water curtain in place while checking the ice formation pattern to ensure no water is lost.

## Evaporator Tubing Routing

Routing of the tubing on the back of the evaporator determines the ice fill pattern failure mode. The evaporator outlet tubing does not exit directly at the top of the evaporator, but exits several inches below the top of the evaporator. Extremely Thin at the Evaporator Outlet will first be visible several inches below the top of the evaporator. Extremely Thin at Evaporator Inlet will first be visible at the bottom of the evaporator.

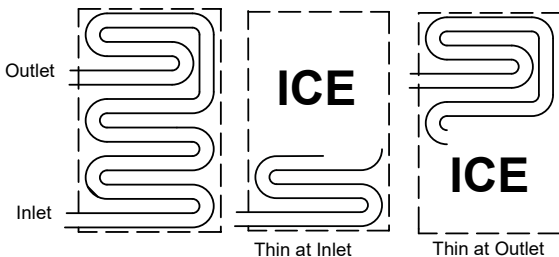

## ICE FORMATION PATTERN IB MODELS

Tubing routing for Ice Beverage evaporators is different. The evaporator outlet is moved lower on the evaporator.

- IB600 and IB800 evaporators outlets exit roughly 1/2 way down the evaporator. Extremely Thin at the Evaporator Outlet will first be visible near the middle of the evaporator
- IB1000 evaporator outlet is roughly 3/4 of the way down the evaporator. Extremely Thin at the Evaporator Outlet will first be visible near the bottom and then the right side of the evaporator.

Extremely Thin at the Evaporator Inlet remains the same as the other models and will first be visible several inches above the bottom of the evaporator.

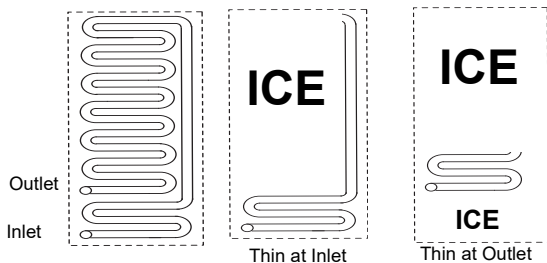

### Ice Formation Patterns

#### 1. Normal Ice Formation

Ice forms across the entire evaporator surface.

At the beginning of the Freeze cycle, it may appear that more ice is forming at the evaporator inlet, than on the evaporator outlet. At the end of the Freeze cycle, ice formation at the outlet will be close to, or just a bit thinner than, ice formation at the inlet. The dimples in the cubes at the outlet of the evaporator may be more pronounced than those at the inlet. This is normal.

It is normal for ice thickness to vary up to 1/16" across the surface of the evaporator. The ice bridge thickness at the ice thickness control probe should be at least 1/8".

The ice thickness probe must be set to maintain the ice bridge thickness at approximately 1/8 in. If ice forms uniformly across the evaporator surface, but does not reach 1/8 in. in the proper amount of time, this is still considered normal ice fill pattern.

## **2. Extremely Thin at Evaporator Outlet**

There is no ice, or a considerable lack of ice formation, at the evaporator outlet.

Examples: No ice at all at the outlet half of the evaporator, but ice forms on the inlet half of the evaporator. Or, the ice at the outlet of the evaporator reaches 1/8 in. to initiate a harvest, but the inlet of the evaporator already has 1/2 in. to 1 in. of ice formation.

## **3. Extremely Thin at Evaporator Inlet**

There is no ice, or a considerable lack of ice formation on the evaporator inlet. Examples: The ice at the outlet of the evaporator reaches 1/8 in. to initiate a harvest, but there is no ice formation at all on the inlet of the evaporator.

## **4. No Ice Formation**

The ice machine operates for an extended period, but there is no ice formation at all on the evaporator.

## Analyzing Discharge Pressure

1. Determine the ice machine operating conditions:

Air temp. entering condenser \_\_\_\_\_

Air temp. around ice machine \_\_\_\_\_

Water temp. entering sump trough \_\_\_\_\_

2. Refer to Cycle Times/24-Hour Ice Production/ Refrigeration Pressure Chart for ice machine being checked.

Use the operating conditions determined in step 1 to find the published normal discharge pressures.

Freeze Cycle \_\_\_\_\_

Harvest Cycle \_\_\_\_\_

3. Perform an actual discharge pressure check.

Freeze  
Cycle psig

1 Minute into  
Freeze Cycle

\_\_\_\_\_

Middle of Freeze Cycle

\_\_\_\_\_

End of Freeze Cycle

\_\_\_\_\_

4. Compare the actual discharge pressure (step 3) with the published discharge pressure (step 2).

The discharge pressure is normal when the actual pressure falls within the published pressure range for the ice machine's operating conditions. It is normal for the discharge pressure to be higher at the beginning of the Freeze cycle (when load is greatest), then drop throughout the Freeze cycle.

## **Discharge Pressure High Checklist**

### ***Improper Installation***

- Refer to “Installation/Visual Inspection Checklist” page 145

### ***Condenser Restriction***

- High inlet air temperature
- Condenser discharge air recirculation
- Dirty condenser fins
- Defective fan cycling control
- Defective fan motor

### ***Improper Refrigerant Charge***

- Overcharged
- Non-condensable in system
- Wrong type of refrigerant

### ***Other***

- Non-Manitowoc components in system
- High side refrigerant lines/component restricted (before mid-condenser)
- Defective head pressure control valve
- Water Inlet Valve is incorrectly adjusted (CVD1486 only)

NOTE: Do not limit your diagnosis to only the items listed in the checklists.

## **Freeze Cycle Discharge Pressure Low Checklist**

### ***Improper Installation***

- Refer to “Installation/Visual Inspection Checklist” page 145

### ***Improper Refrigerant Charge***

- Undercharged
- Wrong type of refrigerant

### ***Other***

- Non-Manitowoc components in system
- High side refrigerant lines/component restricted (before mid-condenser)
- Defective head pressure control valve
- Defective fan cycle control
- Water regulating valve incorrectly set (CVD1486 only)

NOTE: Do not limit your diagnosis to only the items listed in the checklists.

## Analyzing Suction Pressure

The suction pressure gradually drops throughout the Freeze cycle. The actual suction pressure (and drop rate) changes as the air and water temperature entering the ice machine changes. These variables also determine the Freeze cycle times.

To analyze and identify the proper suction pressure drop throughout the Freeze cycle, compare the published suction pressure to the published Freeze cycle time.

NOTE: Analyze discharge pressure before analyzing suction pressure. High or low discharge pressure may be causing high or low suction pressure.

<b>Procedure</b>
<b>Step</b>
1. Determine the ice machine operating conditions. *Temperature of air entering the condenser. Look up and determine the published suction pressure.
2. Perform an actual suction pressure check at the beginning, middle and end of the Freeze cycle. *Freeze cycle begins when the water pump starts
3. Compare the actual Freeze cycle suction pressure (step 2) to the published Freeze cycle pressure. Determine if the suction pressure is high, low or normal.

## **Suction Pressure High Checklist**

### ***Improper Installation***

- Refer to “Installation/Visual Inspection Checklist” page 145

### ***Discharge Pressure***

- Discharge pressure is too high and is affecting suction pressure – refer to “Freeze Cycle Discharge Pressure High Checklist” page 151

### ***Improper Refrigerant Charge***

- Overcharged
- Wrong type of refrigerant
- Non-condensable in system

### ***Other***

- Non-Manitowoc components in system
- Harvest valve leaking
- TXV flooding (check bulb mounting)
- Defective compressor

NOTE: Do not limit your diagnosis to only the items listed in the checklists.

## **Suction Pressure Low Checklist**

### ***Improper Installation***

- Refer to “Installation/Visual Inspection Checklist” page 145

### ***Discharge Pressure***

- Discharge pressure is too low and is affecting suction pressure – refer to “Freeze Cycle Discharge Pressure Low Checklist” page 150

### ***Improper Refrigerant Charge***

- Undercharged
- Wrong type of refrigerant

### ***Other***

- Non-Manitowoc components in system
- Improper water supply over evaporator – refer to “Water System Checklist” page 146
- Loss of heat transfer from tubing on back side of evaporator
- Restricted/plugged liquid line drier
- Restricted/plugged tubing in suction side of refrigeration system
- TXV starving

NOTE: Do not limit your diagnosis to only the items listed in the checklists.

## Harvest Valve

The harvest valve is an electrically operated valve that opens when energized, and closes when de-energized.

### NORMAL OPERATION

The valve is de-energized (closed) during the Freeze cycle and energized (open) during the Harvest cycle. The valve is positioned between the receiver and the evaporator and performs two functions:

1. Prevents refrigerant from entering the evaporator during the Freeze cycle.

The harvest valve is not used during the Freeze cycle. The harvest valve is de-energized (closed) preventing refrigerant flow from the receiver into the evaporator.

2. Allows refrigerant vapor to enter the evaporator in the Harvest cycle.

During the Harvest cycle, the harvest valve is energized (open), allowing refrigerant gas from the top of the receiver to flow into the evaporator. The refrigerant changes state (from a vapor to a liquid) and gives up latent heat. This heat is absorbed by the evaporator and allows release of the ice slab. In general, Harvest cycle suction pressure rises, then stabilizes in the range of 65-125 psig (448-861 kPa).

Exact pressures vary according to ambient temperature and ice machine model. Harvest pressures can be found in the "Cycle Time/ 24-Hour Ice Production/ Refrigerant Pressure Charts" in this book.

## HARVEST VALVE ANALYSIS

The valve can fail in two positions:

- Valve will not open in the Harvest cycle.
- Valve remains open during the Freeze cycle.

### **Valve will not open in the Harvest cycle**

Although the circuit board has initiated a Harvest cycle, suction and discharge pressures remain unchanged from the Freeze cycle. The ice machine will remain in the Harvest cycle for 3.5 minutes (7 minutes Quad Evaporators), then initiate a new Freeze cycle. After three consecutive Harvest cycles of 3.5 minutes (7 minutes Quad Evaporators) the ice machine will stop on a safety limit #2.

### **Valve remains open in the Freeze cycle**

Symptoms of a harvest valve remaining partially open during the Freeze cycle can be similar to symptoms of an expansion valve, float valve or compressor problem. Symptoms are dependent on the amount of leakage in the Freeze cycle.

A small amount of leakage will cause increased freeze times and an ice fill pattern that is normal.

As the amount of leakage increases, the length of the Freeze cycle increases and the amount of ice on the bottom of the evaporator decreases.

A small amount of leakage will cause an audible indication as the vapor passes through the valve. As the size of the leak increases, the audible indication becomes more apparent.

If replacement is necessary, use only "original" Manitowoc replacement parts.

## Analyzing Freeze Cycle Suction Line Temperature

Suction line temperature cannot diagnose an ice machine. However, comparing this temperature during the freeze cycle, along with using Manitowoc's Symptom #2 - Refrigeration System Operational Analysis Table, can help diagnose an ice machine malfunction.

The actual temperature of the suction line varies by model, and will change throughout the freeze cycle. This makes documenting the "normal" suction line temperature difficult. The key to the diagnosis is observing the compressor suction line temperature during the last three minutes of the freeze cycle.

1. Use a quality temperature meter, capable of taking temperature readings on curved copper lines.
2. Attach the temperature meter thermocouple to the copper suction line within 6" of the shut-off valves.

### **Important**

Do not simply insert the sensing device under the insulation. It must be attached to and reading the actual temperature of the copper line.

3. Monitor the suction line temperature during the last three minutes of the freeze cycle and record the low event.
4. Use this with other information gathered on the Refrigeration Component Analysis Chart to determine the ice machine malfunction.
5. Verify refrigerant amount is correct by weight when recovering refrigerant and replacing a TXV. Grossly overcharged QuietQube® ice machine in ambient temperatures below 70°F will have a suction line temperature below 10°F.

## **Final Analysis**

The column with the highest number of check marks identifies the refrigeration problem.

### **COLUMN 1 - HARVEST VALVE LEAKING**

A leaking harvest valve must be replaced.

### **COLUMN 2 - LOW CHARGE OR TXV STARVING**

Normally, a starving expansion valve only affects the freeze cycle pressures, not the harvest cycle pressures. A low refrigerant charge normally affects both pressures. Verify the ice machine is not low on charge before replacing an expansion valve.

1. Do not add charge to remotes. The symptoms of a remote low on charge will result in a safety limit #1 or #2 in cool ambient temperatures. Low on charge symptoms would be a hot liquid line with normal or below normal head pressure.
2. Find the refrigerant leak. The ice machine must operate with the nameplate charge. If the leak cannot be found, proper refrigerant procedures must still be followed Change the liquid line drier. Then, evacuate and weigh in the proper charge.

### **COLUMN 3 - REFRIGERANT OVERCHARGE OR TXV FLOODING**

A loose or improperly mounted expansion valve bulb causes the expansion valve to flood. Check bulb mounting, insulation, etc., before changing the valve. Verify refrigerant amount is correct by weighing recovered refrigerant before replacing a TXV. On Quad evaporator machines, the service technician is able to tell which TXV is flooding by comparing the evaporator outlets. Change only the flooding expansion valve.

### **COLUMN 4 - COMPRESSOR**

Replace the compressor and start components. To receive warranty credit, the compressor ports must be soldered closed to prevent oil leakage in transit.

NOTE: This table must be used with charts, checklists and other references to eliminate refrigeration components not listed on the table and external items and problems, which can cause good refrigeration components to appear defective.

## Symptom #3 Ice Will Not Harvest

### ICE MACHINE WILL NOT HARVEST DIAGNOSTICS

Ice release issues fall into two main categories mechanical or refrigeration. The first step in solving an ice release issue is to determine which condition exists. At the end of the harvest cycle place the toggle switch in the OFF position, then remove and inspect the sheet of ice.

- If the cubes are well defined and show no signs of melting a refrigeration problem is indicated.
- If the cubes are deformed and melted away (sharks teeth) a mechanical problem is indicated. Something on the evaporator is causing the harvest problem.
- Always clean the evaporator before diagnosing the refrigeration system.
- The water curtain must swing freely open and closed and the bin switch must function properly.

## HARVEST PROBLEMS

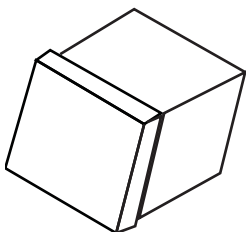

**Normal Ice Cube**

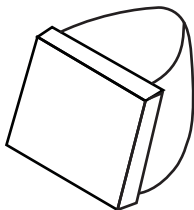

**Melted Out Ice Cube**

Definition of a harvest problem; At the end of a 3.5 minute harvest cycle the slab of ice is still contacting the evaporator. The slab of ice may or may not be removable by hand.

Harvest problems can be split into two categorizes.

- Melted sheet of cubes at the end of the harvest cycle. Ice can be removed rather easily by hand. The back of the cubes are misshapen and melted. This indicates something is on the evaporator preventing the ice slab from releasing. A manual cleaning procedure must always be performed when this problem is encountered.
- Normal sheet of cubes at the end of the harvest cycle. Ice is difficult to remove from the evaporator by hand. Once removed the back of the cubes are square and show no signs of melting. This indicates a refrigeration problem. The source of the problem could be in the freeze or harvest cycle. Use the appropriate flow chart (in Troubleshooting) to determine the cause of the problem.

## Symptom #3 Ice Will Not Harvest, Cubes Are Not Melted Flowchart

### Ice Machine Will Not Harvest Freeze Cycle is Normal and Ice Cubes Are Not Melted After Harvest

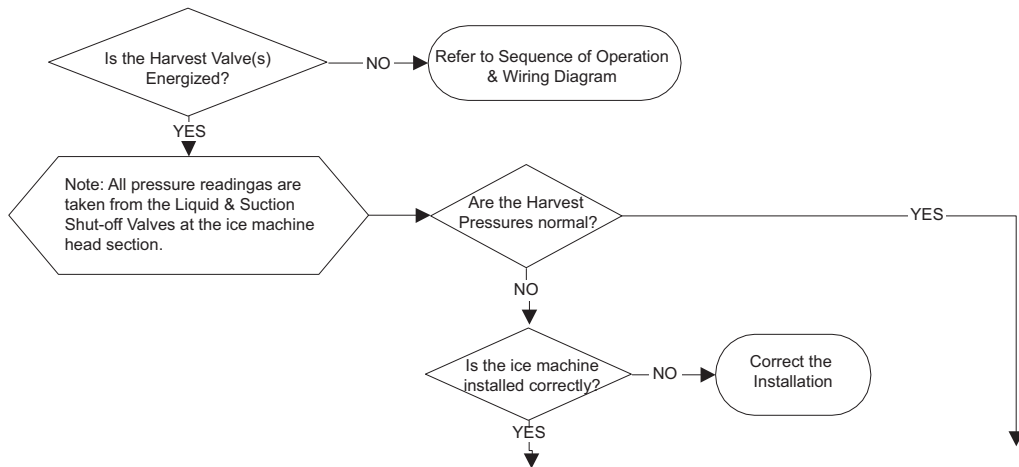

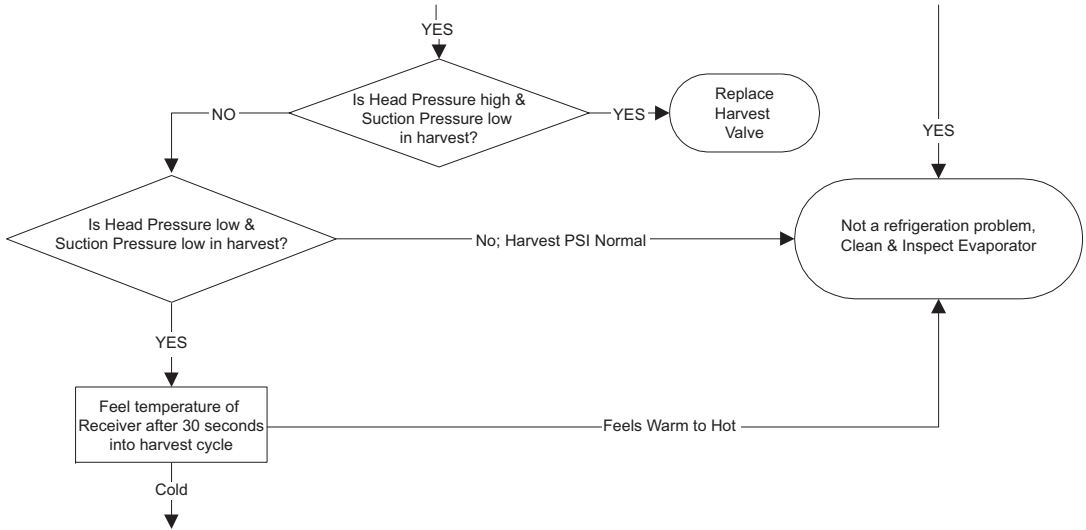

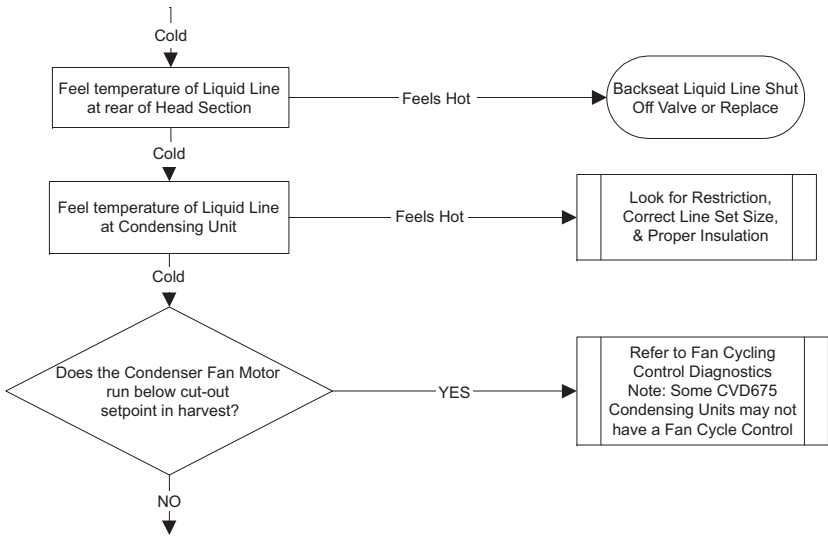

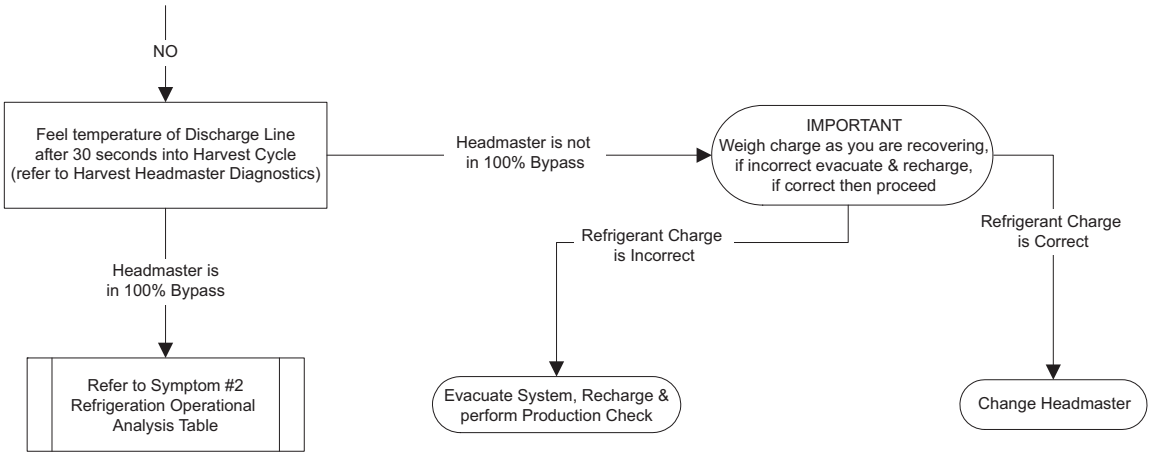

## Symptom #4 Ice Will not Harvest - Cubes Are Melted Flowchart

Ice Machine Will Not Harvest - Freeze Cycle Is Normal and Ice Cubes Are Melted After Harvest

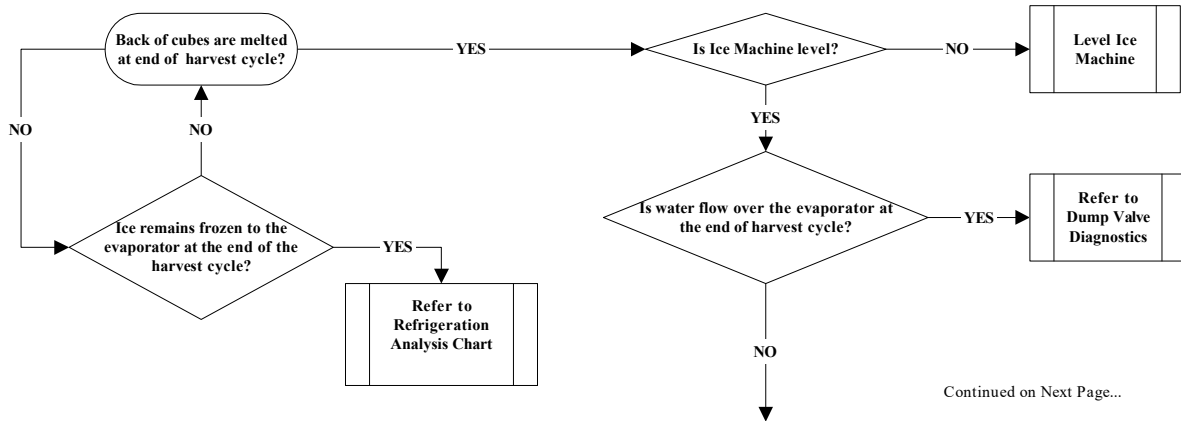

Continued on Next Page...

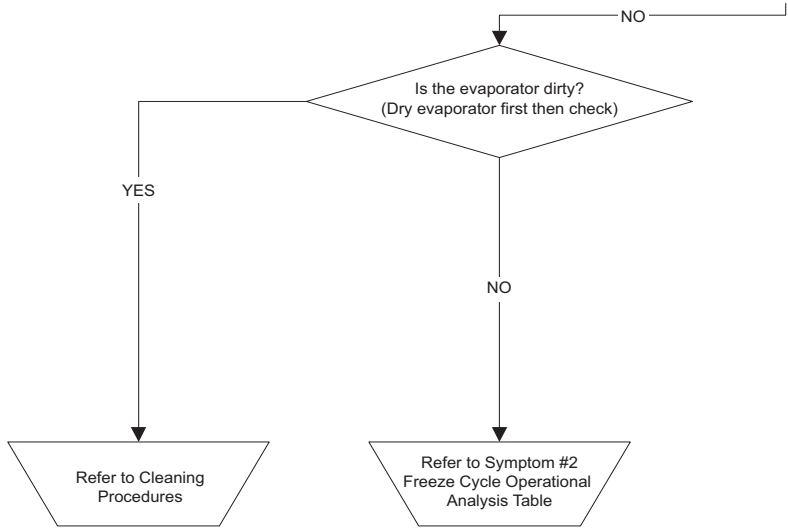

**This Page Intentionally Left Blank**

# Component Check Procedures

## Electrical Components

### MAIN FUSE

#### FUNCTION

The control board fuse stops ice machine operation if electrical components fail, causing high amp draw.

#### SPECIFICATIONS

The main fuse is 250 Volt, 7 amp.

#### **Warning**

High (line) voltage is applied to the control board (terminals #55 and #56) at all times. Removing the control board fuse or moving the toggle switch to OFF will not remove the power supplied to the control board.

#### CHECK PROCEDURE

1. If the bin switch light is on with the water curtain closed, the fuse is good.

#### **Warning**

Disconnect electrical power to the entire ice machine before proceeding.

2. Remove the fuse. Check the resistance across the fuse with an ohmmeter.

Reading	Result
Open (OL)	Replace fuse
Closed (O)	Fuse is good

## **BIN SWITCH**

### FUNCTION

Movement of the water curtain/ice dampers control bin switch operation. The bin switch has two main functions:

1. Terminating the Harvest cycle and returning the ice machine to the Freeze cycle. This occurs when the bin switch is opened and closed again within 30 seconds during the Harvest cycle.
2. Automatic ice machine shut-off.  
If the storage bin is full at the end of a Harvest cycle, the sheet of cubes fails to clear the water curtain/ice dampers and holds it open. After the water curtain/ice dampers are held open for 30 seconds, the ice machine shuts off. The ice machine remains off until enough ice is removed from the storage bin to allow the sheet of cubes to drop clear of the water curtain/ice dampers. As the water curtain/ice dampers swing back to the operating position, the bin switch closes and the ice machine restarts, provide the 3-minute delay has expired.

### **Important**

The water curtain/ice dampers must be ON (bin switch closed) to start ice making.

### SPECIFICATIONS

The bin switch is a magnetically operated reed switch. The magnet is attached to the lower right corner of the water curtain/ice dampers. The switch is attached to the right bulkhead wall.

The bin switch is connected to a varying D.C. voltage circuit. (Voltage does not remain constant.)

**NOTE:** Because of a wide variation in D.C. voltage, it is not recommended that a voltmeter be used to check bin switch operation.

## SYMPTOMS

### Bin Switch Fails Open

- The ice machine will not start with the toggle switch in the ice position, but runs normally with the toggle switch in the clean position.

### Bin Switch Fails Closed

- Safety limit 2 is recorded in the control board memory and the harvest cycle continues after the ice opens and closes the water curtain/ice dampers (harvest cycle is 3.5 minutes for single & twin evaporators and 7 minutes for quad evaporator models).

## DIAGNOSTIC AIDS:

- Always use the water curtain/ice dampers magnet to cycle the switch (a larger or smaller magnet will affect switch operation).
- Readings are affected by your test lead connection and VOM battery strength. Verify you have solid connections and a correctly functioning VOM before testing bin switch.
- Open the curtain/ice dampers for 3 seconds, then close the curtain/ice dampers for 3 seconds. This will allow your VOM display to settle.
- With the bin switch closed your meter reading should be 0 (0 to 10 is acceptable). With the curtain/ice dampers open the reading must be infinity (OL).

## CONTINUITY TEST

1. Disconnect the bin switch wires to isolate the bin switch from the control board.
2. Connect an ohmmeter to the disconnected bin switch wires.
3. Cycle the bin switch open and closed 25 times by opening and closing the water curtain/ice dampers. Watch for consistent readings each time the bin switch is cycled open and closed (bin switch failure could be erratic).

## **Water Curtain/Ice Damper Removal Notes**

The water curtain must be on (bin switch closed) to start ice making. While a Freeze cycle is in progress, the water curtain can be removed and installed at any time without interfering with the electrical control sequence.

If the ice machine goes into Harvest sequence while the water curtain is removed, one of the following will happen:

- Water curtain remains off:  
When the Harvest cycle time reaches 3.5 minutes and the bin switch is not closed, the ice machine stops as though the bin were full.
- Water curtain is put back on:  
If the bin switch closes prior to reaching the 3.5-minute point, the ice machine immediately returns to another Freeze sequence pre chill.

## **HARVEST ASSIST AIR PUMP**

### **FUNCTION**

The air pump breaks the vacuum between the sheet of ice and the evaporator which results in shorter harvest cycles.

### **SPECIFICATIONS**

115 Volt or 230 Volt - matches the ice machine voltage.

### **CHECK PROCEDURE**

1. Verify when the air pump should be running in the sequence of operation.
2. If the compressor is not running when it should be check voltage at the control board.
3. If there is no voltage present at the control board, replace the control board.
4. If there is voltage present at the control board check for voltage at the air pump connector.
5. If there is no voltage present at the air pump connector replace wire.
6. If there is voltage at the air pump connector, use a volt ohm meter to verify there is no continuity through the motor windings then replace motor.

## ICE/OFF/CLEAN TOGGLE SWITCH

### FUNCTION

The switch is used to place the ice machine in ICE, OFF or CLEAN mode of operation.

### SPECIFICATIONS

Single-pole, double-throw switch. The switch is connected into a varying low D.C. voltage circuit.

### CHECK PROCEDURE

NOTE: Because of a wide variation in D.C. voltage, it is not recommended that a voltmeter be used to check toggle switch operation.

1. Inspect the toggle switch for correct wiring.
2. Isolate the toggle switch by disconnecting the Molex connector.
3. Check across the toggle switch terminals. Note where the wire numbers are connected to the switch terminals, or refer to the wiring diagram to take proper readings.

Switch Setting	Terminals	Ohm Reading
ICE	1-6	Open
	1-2	Closed
	2-6	Open
CLEAN	1-6	Closed
	1-2	Open
	2-6	Open
OFF	1-6	Open
	1-2	Open
	2-6	Open

4. Replace the toggle switch if ohm readings do not match all three switch settings.

## **IB Model Ice Machines** **Before Serial Number 050400000**

### FUNCTION

The switch is used to place the ice machine in ICE, OFF or CLEAN mode of operation.

### SPECIFICATIONS

Double-pole, double-throw switch. The switch is connected into a varying low D.C. voltage circuit.

### CHECK PROCEDURE

NOTE: Because of a wide variation in D.C. voltage, it is not recommended that a voltmeter be used to check toggle switch operation.

1. Inspect the toggle switch for correct wiring.
2. Isolate the toggle switch by disconnecting all wires from the switch, or by disconnecting the Molex connector and removing wire #69 from the toggle switch.
3. Check across the toggle switch terminals using a calibrated ohmmeter. Note where the wire numbers are connected to the switch terminals, or refer to the wiring diagram to take proper readings.

<b>Switch Setting</b>	<b>Terminals</b>	<b>Ohm Reading</b>
ICE	66-62	Open
	67-68	Closed
	67-69	Open
CLEAN	66-62	Closed
	67-68	Open
	67-69	Closed
OFF	66-62	Open
	67-68	Open
	67-69	Open

4. Replace the toggle switch if ohm readings do not match all three switch settings.

## **ICE THICKNESS PROBE (HARVEST INITIATION)**

### **HOW THE PROBE WORKS**

Manitowoc's electronic sensing circuit does not rely on refrigerant pressure, evaporator temperature, water levels or timers to produce consistent ice formation.

As ice forms on the evaporator, water (not ice) contacts the ice thickness probe. After the water completes this circuit across the probe continuously for 10 seconds, a Harvest cycle is initiated.

### **ICE PROBE LIGHT**

This light's primary function is to be on as water contacts the ice thickness probe during the freeze cycle, and remain on throughout the entire harvest cycle. The light will flicker as water splashes on the probe.

### **FREEZE TIME LOCK-IN FEATURE**

The ice machine control system incorporates a freeze time lock-in feature. This prevents the ice machine from short cycling in and out of harvest.

The control board locks the ice machine in the freeze cycle for six minutes. If water contacts the ice thickness probe during these six minutes, the harvest light will come on (to indicate that water is in contact with the probe), but the ice machine will stay in the freeze cycle. After the six minutes are up, a harvest cycle is initiated. This is important to remember when performing diagnostic procedures on the ice thickness control circuitry.

To allow the service technician to initiate a harvest cycle without delay, this feature is not used on the first cycle after moving the toggle switch OFF and back to ICE.

## MAXIMUM FREEZE TIME

The control system includes a built-in safety which will automatically cycle the ice machine into harvest after 60 minutes in the freeze cycle.

## ICE THICKNESS CHECK

The ice thickness probe is factory-set to maintain the ice bridge thickness at 1/8 in. (.32 cm).

NOTE: Make sure the water curtain is in place when performing this check. It prevents water from splashing out of the water trough.

1. Inspect the bridge connecting the cubes. It should be about 1/8 in. (.32 cm) thick.
2. If adjustment is necessary, turn the ice thickness probe adjustment screw clockwise to increase bridge thickness or counterclockwise to decrease bridge thickness. Set a 1/4" gap between the ice thickness probe and evaporator as a starting point. Then adjust to achieve 1/8" ice thickness.

NOTE: The starting point before final adjustment is approximately a 1/4 in. gap.

Make sure the ice thickness probe wire and the bracket do not restrict movement of the probe

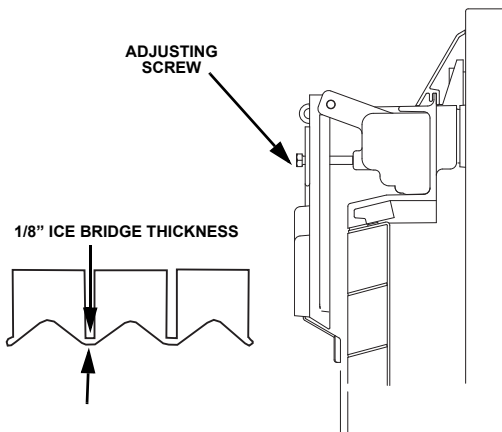

SV3132

## **ICE THICKNESS ADJUSTMENT**

## Cleaning the Ice Thickness Probe

Clean the ice thickness probe using the following procedure.

1. Mix a solution of Manitowoc ice machine cleaner and water (2 ounces of cleaner to 16 ounces of water) in a container.
2. Soak ice thickness probe in container of cleaner/ water solution while disassembling and cleaning water circuit components (soak ice thickness probe for 10 minutes or longer).
3. Clean all ice thickness probe surfaces including all plastic parts (do not use abrasives). Verify the ice thickness probe cavity is clean. Thoroughly rinse ice thickness probe (including cavity) with clean water, then dry completely. **Incomplete rinsing and drying of the ice thickness probe can cause premature harvest.**
4. Reinstall ice thickness probe, then sanitize all ice machine and bin/dispenser interior surfaces.

## **Diagnosing Ice Thickness Control Circuitry**

### **PROBLEM: ICE MACHINE DOES NOT CYCLE INTO HARVEST WHEN WATER CONTACTS THE ICE THICKNESS CONTROL PROBE**

**Step 1** Bypass the freeze time lock-in feature by moving the ICE/OFF/CLEAN switch to OFF and back to ICE.

**Step 2** Wait until water starts to flow over the evaporator (freeze cycle).

**Step 3** Disconnect the ice thickness control from the control board, then connect a jumper wire from the control board to any cabinet ground and monitor the ice probe light.

#### **Ice Probe Light On**

- The ice probe light comes on, and 10 seconds later, the ice machine cycles from Freeze to Harvest.

The ice thickness probe is causing the malfunction.

- The ice probe light comes on, but the ice machine stays in the Freeze sequence.

The control board is causing the malfunction.

#### **Ice Probe Light Off**

- The ice probe light does not come on.

The control board is causing the malfunction.

If you suspect a defective probe check for continuity from the ice thickness probe to the connector.

- With continuity DO NOT change the probe.
- Without continuity, the probe is defective.

PROBLEM: ICE MACHINE CYCLES INTO HARVEST BEFORE WATER CONTACT WITH THE ICE THICKNESS PROBE

**Step 1** Bypass the freeze time lock-in feature by moving the ICE/OFF/CLEAN switch to OFF and back to ICE.

**Step 2** Disconnect the ice thickness probe from the control board

**Step 3** Wait until water starts to flow over the evaporator, then monitor the ice probe light:

**Ice Probe Light Off**

- The ice probe light stays off, and the ice machine remains in the Freeze sequence.

The ice thickness probe is causing the malfunction. Verify that the ice thickness probe is adjusted correctly and clean.

**Ice Probe Light On**

- The ice probe light comes on, and 10 seconds later, the ice machine cycles from Freeze to Harvest.

The control board is causing the malfunction.

## **WATER LEVEL CONTROL CIRCUITRY**

The water level probe circuit can be monitored by watching the water level light. The water level light is on when water contacts the probe, and off when no water is in contact with the probe. The water level light functions any time power is applied to the ice machine, regardless of toggle switch position.

### **FREEZE CYCLE WATER LEVEL SETTING**

During the Freeze cycle, the water level probe is set to maintain the proper water level above the water pump housing. The water level is not adjustable. If the water level is incorrect, check the water level probe position. Reposition or replace the probe as necessary.

### **WATER INLET VALVE SAFETY SHUT-OFF**

In the event of a water level probe failure, this feature limits the water inlet valve to a 6-minute on time. Regardless of the water level probe input, the control board automatically shuts off the water inlet valve if it remains on for 12 continuous minutes. This is important to remember when performing diagnostic procedures on the water level control circuitry.

## FREEZE CYCLE CIRCUITRY

Manitowoc's electronic sensing circuit does not rely on float switches or timers to maintain consistent water level control. During the Freeze cycle, the water inlet valve energizes and de-energizes in conjunction with the water level probe located in the water trough.

### **During the first 45 seconds of the Freeze cycle:**

The water inlet valve is ON when there is no water in contact with the water level probe.

- The water inlet valve turns OFF after water contacts the water level probe for 3 continuous seconds.
- The water inlet valve will cycle ON and OFF as many times as needed to fill the water trough.

### **After 45 seconds into the Freeze cycle:**

The water inlet valve will cycle ON, and then OFF one more time to refill the water trough. The water inlet valve is now OFF for the duration of the Freeze sequence.

## HARVEST CYCLE CIRCUITRY

The water level probe does not control the water inlet valve during the harvest cycle. During the harvest cycle water purge, the water inlet valve energizes and de-energizes strictly by time. The harvest water purge jumper may be set at 45 seconds (top and center terminals) or 0 seconds (center and bottom terminals). Set the harvest water purge to 0 seconds when reverse osmosis or deionized water is used. Use the factory setting of 45 seconds for all other types of water.

### **HARVEST WATER PURGE ADJUSTMENT**

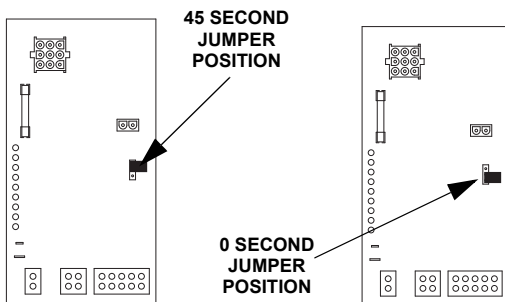

## Diagnosing Water Level Control Circuitry

PROBLEM: WATER TROUGH OVERFILLING  
DURING THE FREEZE CYCLE

**Step 1** Start a new Freeze sequence by moving the ICE/OFF/CLEAN toggle switch to OFF and then back to ICE.(if water flows with the switch off, check the water inlet valve).

### Important

This restart must be done prior to performing diagnostic procedures. This assures the ice machine is not in a Freeze cycle water inlet valve safety shut-off mode. You must complete the entire diagnostic procedure within 6 minutes of starting.

**Step 2** Wait until the Freeze cycle starts (the Freeze cycle starts when the water pump energizes).

**Step 3** Disconnect the water level probe from the control board, then connect a jumper from the control board terminal and any cabinet ground, then refer to chart on next page.

### Important

For the test to work properly you must wait until the Freeze cycle starts, prior to disconnecting the water level probe. If you restart the test, you must reconnect the water level probe, restart the ice machine (step 1), and then disconnect the water level probe after the compressor starts.

## WATER TROUGH OVERFILLING CONTINUED

<b>Step 3. Jumper Wire Connected from Control Board Terminal to Ground</b>			
<b>Is Water Flowing into the Water Trough?</b>	<b>The Water Level Light Is:</b>	<b>The Water Inlet Valve Solenoid Coil Is:</b>	<b>Cause</b>
No	On	De-energized	The water level probe is causing the problem. Ohm, then clean or replace the water level probe.
Yes	Off	Energized	The control board is causing the problem.
Yes	On	De-energized	The water fill valve is causing the problem.

## **Problem: Water Will Not Run into the Sump Trough During the Freeze Cycle**

**Step 1** Verify water is supplied to the ice machine. Start a new Freeze sequence by moving the ICE/OFF/CLEAN toggle switch to OFF, then back to ICE.

**Step 2** Wait until the freeze cycle starts (approximately 45 seconds, the freeze cycle starts when the compressor energizes).

### **Important**

This restart must be done prior to performing diagnostic procedures. This assures the ice machine is not in a freeze cycle water inlet valve safety shut-off mode. You must complete the entire diagnostics within 6 minutes of starting.

**Step 3** Disconnect the water level probe from the water level probe terminal on the control board.

### Important

For the test to work properly you must wait until the Freeze cycle starts, prior to disconnecting the water level probe. If you restart the test, you must reconnect the water level probe, restart the ice machine (step 1), and then disconnect the water level probe after the compressor starts.

#### Step 3. Disconnect Probe from Control Board

Is Water Flowing into the Water Trough?	The Water Level Light Is:	The Water Inlet Valve Solenoid Coil Is:	Cause
Yes	Off	Energized	The water level probe is causing the problem. Clean or replace the water level probe.
No	Off	Energized	The water inlet valve is causing the problem.
No	On or Off	De-energized	The control board is causing the problem.

## **ELECTRONIC BIN THERMOSTAT CONTROL**

The temperature control opens the bin switch circuit when ice contacts the sensor. When ice no longer contacts the sensor, the circuit closes and the ice machine starts.

### **SPECIFICATIONS**

Setpoint Range: -30 to 212°F (-34 - 100°C)

### **CONTROL SETTINGS**

Verify control is set properly before proceeding.

<b>Display</b>	<b>Function</b>	<b>Preset Settings</b>
SP	Set Point	40
DIF	Differential	1
ASD	Anti-Short Cycle Delay	1
OFS	Temperature Offset	0
SF	Sensor Failure Mode	1

### **POSITIONING THE TOUCH PAD JUMPERS**

#### **P5 Jumper**

The P5 jumper position determines if the touch pad is locked or unlocked. The control is factory locked; to unlock move the jumper from one pin to two pins.

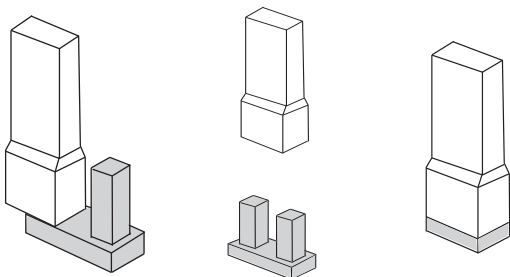

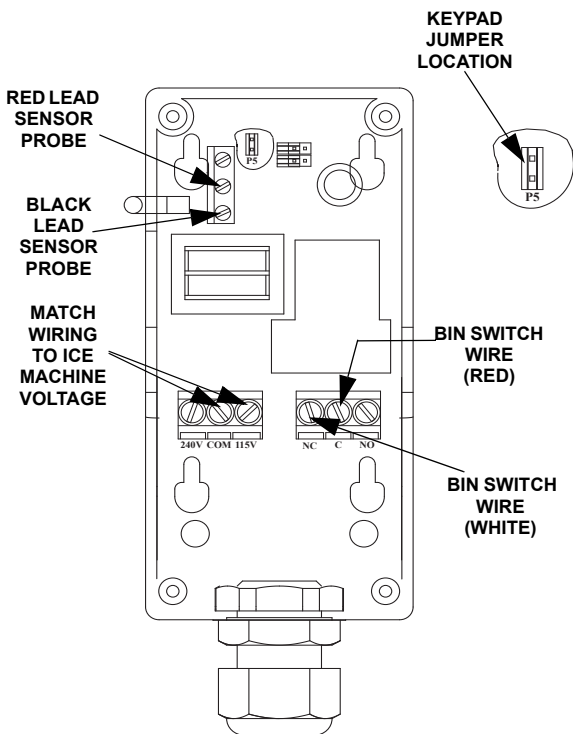

### Inside of Bin Thermostat Control

#### P4 Jumper

The P4 jumper labeled Jump 1 is used to set the control for heating or cooling mode. Jump 2 is used to establish Setpoint at either cut-in or cutout.

#### Cooling Mode Cut-Out at Setpoint

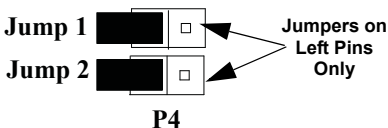

## SETTING CONTROL SETPOINT VALUE

To view and adjust setpoint, follow these steps:

1. Press MENU until the display flashes SP.
2. Press MENU again to display the existing setpoint value.
3. Press Up or Down (arrows) to change the setpoint value.
4. Press MENU again to save the new value. The display returns to the sensed temperature.

NOTE: If no setup entry is made for 30 seconds, the control reverts to the normal temperature display.

### **Important**

If MENU is not pressed after changing the setpoint value, the control reverts to the previously programmed setpoint value.

## DIFFERENTIAL, ANTI-SHORT CYCLE DELAY, TEMPERATURE OFFSET, OR SENSOR FAILURE OPERATION

To set or verify the Differential, Anti-Short Cycle Delay, Temperature Offset or Sensor Failure Operation use the following method.

Factory Preset Temperature Control Code Settings as follows:

1. Press and hold MENU until the display changes to flashing SP.
2. Press up and down (arrows) repeatedly until the desired function is displayed.
3. Press MENU to display the function's current value.
4. Press up and down (arrows) until the desired value is displayed.
5. Press MENU to save the new value. The display returns to the sensor temperature.

NOTE: If no setup entry is made for 30 seconds, the control reverts to the temperature display.

NOTE: Any saved control settings are non-volatile and remain in the control's memory during power interruptions.

## CHECK PROCEDURE

### **Warning**

Line voltage is present inside control. Contact with line voltage can cause serious injury or death.

If the control system does not function properly, verify that the control is wired and set up properly. If the problem persists use the following procedures to determine the cause of the problem.

1. Check the proper voltage to the control.
  - A. Remove the cover, loosen the four cover screws.
  - B. Use an AC voltmeter to check the voltage between the common and 120V or 240V terminals.
  - C. The voltage must be between 102 and 132 volts for 120V applications, 177 and 264 volts for 208/230V applications.
  - D. If the voltage reading is not within the required range, check the power source and input power wires for problems.

### 2. Fault Codes

If the LCD displays an alarm or fault code (SF or EE):

<b>Fault Code</b>	<b>Definition</b>	<b>Solution</b>
SF flashing alternately with OP	Open temperature sensor or sensor wiring	See Step 3. Cycle power to reset control.
SF flashing alternately with SH	Shorted temperature sensor or sensor wiring	See Step 3. Cycle power to reset control.
EE	Program failure	Reset the control by pressing MENU. If problem persists, replace the control.

### 3. Check for proper operation.

NOTE: Perform Steps 1 and 2 before performing this step.

- A. Disconnect the load from the output relay terminals.
- B. Reconnect the sensor leads and supply power to the control.
- C. Replace the cover.
- D. Check the control settings for proper values.
- E. Press and hold MENU until SP appears.
- F. Press up and down (arrows) to change the setpoint temperature above and below the sensor temperature until the relay energizes and de-energizes.
- G. If the output relay does not perform as indicated replace the control.
- H. If proper operation of the control is verified, reconnect the load.

## **COMPRESSOR ELECTRICAL DIAGNOSTICS**

The compressor does not start or will trip repeatedly on overload.

### **Check Resistance (Ohm) Values**

NOTE: Compressor windings can have very low ohm values. Use a properly calibrated meter.

Perform the resistance test after the compressor cools. The compressor dome should be cool enough to touch (below 120°F/49°C) to assure that the overload is closed and the resistance readings will be accurate.

### **SINGLE PHASE COMPRESSORS**

1. Disconnect power then remove the wires from the compressor terminals.
2. The resistance values between C and S and between C and R, when added together, should equal the resistance value between S and R.
3. If the overload is open, there will be a resistance reading between S and R, and open readings between C and S and between C and R. Allow the compressor to cool, then check the readings again.

### **THREE PHASE COMPRESSORS**

1. Disconnect power and remove the wires from the compressor terminals.
2. The resistance values between L1 and L2, between L2 and L3, and between L3 and L1 should all be equal.
3. If the overload is open, there will be open readings between L1 and L2, between L2 and L3, and between L3 and L1. Allow the compressor to cool, then check the readings again.

## CHECK MOTOR WINDINGS TO GROUND

Check continuity between all three terminals and the compressor shell or copper refrigeration line. Scrape metal surface to get good contact. If continuity is present, the compressor windings are grounded and the compressor should be replaced.

## COMPRESSOR DRAWING LOCKED ROTOR

To determine if the compressor is seized, check the amp draw while the compressor is trying to start.

The two likely causes of this are a defective starting component and a mechanically seized compressor.

To determine which you have:

1. Install high and low side gauge set.
2. Try to start the compressor.
3. Watch the pressures closely.
  - A. If the pressures do not move, the compressor is seized. Replace the compressor.
  - B. If the pressures move, the compressor is turning slowly and is not seized. Check the capacitors and relay.

## COMPRESSOR DRAWING HIGH AMPS

The continuous amperage draw on start-up should not be near the maximum fuse size indicated on the serial tag.

## **DIAGNOSING START COMPONENTS**

If the compressor attempts to start, or hums and trips the overload protector, check the start components before replacing the compressor.

### **Capacitor**

Visual evidence of capacitor failure can include a bulged terminal end or a ruptured membrane. Do not assume a capacitor is good if no visual evidence is present. A good test is to install a known good substitute capacitor. Use a capacitor tester when checking a suspect capacitor. Clip the bleed resistor off the capacitor terminals before testing.

### **Relay**

The relay has a set of contacts that connect and disconnect the start capacitor from the compressor start winding. The contacts on the relay are normally closed (start capacitor in series with the start winding). The relay senses the voltage generated by the start winding and opens the contacts as the compressor motor starts. The contacts remain open until the compressor is de-energized.

### **Relay Operation Check**

1. Disconnect wires from relay terminals.
2. Verify the contacts are closed.  
Measure the resistance between terminals 1 and 2. No continuity indicates open contacts. Replace the relay.
3. Check the relay coil.  
Measure the resistance between terminals 2 and 5. No resistance indicates an open coil. Replace the relay.

## PTCR

The PTCR allows current to flow through the start winding at compressor startup. Current flow heats the ceramic discs in the PTCR. The electrical resistance increases with temperature and stops all except a trickle of current flow through the start winding. The small flow of current keeps the PTCR hot (260°F/ 127°C) and the start winding out of the circuit.

The PTCR must be cooled before attempting to start the compressor, otherwise the PTCR will heat up too quickly and stop current flow through the start winding before the compressor motor reaches full speed..



### **Warning**

Disconnect electrical power to the entire ice machine at the building electrical disconnect box before proceeding.

NOTE: If a PTCR is dropped internal damage can occur to the ceramic PTCR discs. The ceramic disc can chip and cause arcing which leads to PTCR failure. Since there is no way to open the PTCR in order to determine if the ceramic disc is chipped or not, it must be discarded when dropped.

## PTCR Operation Check

1. Visually inspect the PTCR. Check for signs of physical damage.

**NOTE:** The PTCR case temperature may reach 210°F (100°C) while the compressor is running. This is normal. Do not change a PTCR just because it is hot.

2. Wait at least 10 minutes for the PTCR to cool to room temperature.
3. Remove the PTCR from the ice machine.
4. Measure the resistance of the PTCR as shown. At room temperature the resistance reading must be between 8 & 22 ohms.

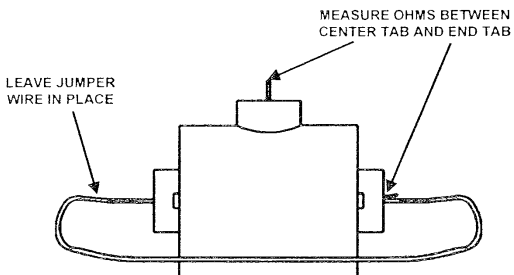

# Refrigeration Components

## REFRIGERANT CHARGE VERIFICATION

QuietQube remote ice machines require the correct amount of refrigerant (name plate charge) to operate correctly at all ambient conditions.

An ice machine with an overcharge or undercharge of refrigerant may function properly at higher ambient temperatures and fails at lower ambient temperatures. Symptoms of incorrect refrigerant amount are:

- Works during the day and malfunctions at night, and/or fails whenever the outdoor temperature drops.
- A Safety limit is stored in control board memory.

Refrigerant loss and ambient temperature are directly related to each other. As the ambient temperature drops, more refrigerant is stored in the condenser.

When the refrigerant charge and ambient temperature create an undercharge of refrigerant in the freeze cycle, the receiver dip tube will lose it's liquid seal. Without liquid refrigerant to the TXV, the ice machine fails to make a full sheet of ice in 60 minutes and a safety limit #1 results.

When the refrigerant charge and ambient temperature create a marginal undercharge of refrigerant, the ice machine will be able to make a full sheet of ice, but fails in the harvest cycle and a safety limit #2 results.

NOTE: Depending on the amount of refrigerant loss and ambient temperature, the ice machine may harvest for one or two cycles when restarted after an "Automatic Shut-off" (ice machine pumped down and shut off on low pressure control).

When refrigerant charge is suspected, verify by recovering the refrigerant, weighing and comparing to the nameplate amount. Refer to "Refrigerant Recovery/Evacuation" page 211 for recovery procedures.

### ***Undercharge Symptoms***

- Safety limit #1 or Safety limit #2 in control board memory.
- Harvest cycle suction pressure is low.
- Harvest cycle discharge pressure is low.
- Liquid line entering receiver feels warm to hot in the freeze cycle.

### **Overcharge Symptoms**

- Safety limit #2 in control board memory.
- Harvest cycle suction pressure is low.
- Harvest cycle discharge pressure is normal.
- Freeze cycle time, suction and discharge pressure are normal and the ice machine will not harvest. The sheet of ice cubes show little or no sign of melting when removed from the evaporator after the harvest cycle has been completed. (If the cubes are melted you have a release problem, clean the ice machine).

## SUCTION ACCUMULATOR OPERATION

Liquid refrigerant collects in the suction accumulator during the harvest cycle and is removed during the freeze cycle. The liquid refrigerant is returned to the compressor through a screen and orifice in the suction accumulator J tube. Passing the liquid through the orifice causes a pressure drop; the liquid flashes to a vapor and creates a refrigeration affect. It is normal to see frost on the accumulator, suction line and compressor suction port in the freeze cycle. The suction accumulator empties within the first 5 minutes of the freeze cycle. When the refrigeration affect ends (liquid refrigerant has been removed), the suction line between the accumulator and compressor will increase in temperature. The suction line temperature increases 20 plus degrees within 2 minutes after the liquid has been removed.

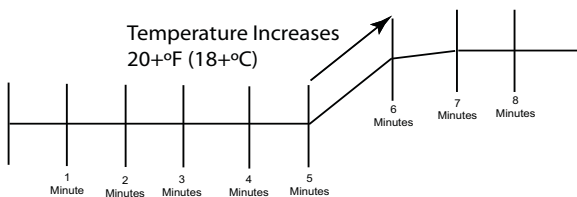

The time needed to remove the liquid refrigerant will vary with the ambient temperature and the length of the harvest cycle. Higher ambient temperatures = shorter harvest cycles, faster removal of liquid refrigerant from the accumulator and greater suction line temperature increases.

## HEADMASTER CONTROL VALVE

### Function

The headmaster control valve maintains the correct discharge pressure and liquid line temperature in the Freeze and Harvest cycles.

Manitowoc QuietQube® systems require headmaster control valves with special settings. Replace defective headmaster control valves only with “original” Manitowoc replacement parts.

### Freeze Cycle Operation

During low ambient conditions, it is normal for the head pressure control valve to hunt (head pressure may fluctuate up and down) on CVD condensing units. Hunting varies by model and ambient, but generally settles out within the first 6 minutes of the freeze cycle.

At ambient temperatures of approximately 70°F (21°C) or above, refrigerant flows through the valve from the condenser to the receiver inlet. At temperatures below this (or at higher temperatures if it is raining), the head pressure control starts to modulate (closes the condenser port and opens the bypass port from the compressor discharge line).

In this modulating mode, the valve maintains minimum head pressure by building up liquid in the condenser and bypassing discharge gas directly to the receiver.

### **Important**

Head pressure settings will vary depending on the QuietQube® model being worked on.

## Harvest Cycle Operation

During the Harvest cycle, the harvest valve opens and allows refrigerant from the top of the receiver tank to enter the evaporator. The refrigerants change of state (from vapor to liquid) releases the heat necessary for the Harvest cycle.

Opening the harvest valve causes a drop in discharge pressure.

The discharge pressure will drop below the condenser fan cycling control setpoint and the condenser fan motor cycles off (at ambient temperatures above 110°F (43°C) the condenser fan motor remains energized).

The warm discharge gas adds heat to the receiver in the harvest cycle. Without this additional heat the head pressure would continue to drop as liquid refrigerant boils off in the receiver.

Example: A service technician removes refrigerant vapor from a cylinder by boiling off the liquid refrigerant. A refrigeration effect is created as the refrigerant changes state from a liquid to a vapor. The cylinder cools and the refrigerant pressure drops. To maximize flow and maintain pressure the technician places the cylinder in warm water.

A head pressure control valve that will not completely bypass in the harvest cycle will result in longer harvest cycles with lower than normal suction pressure and safety limit #2 trips.

(Refer to the "Cycle Times/24 Hr Ice Production/ Refrigerant Pressure Charts" for the model being worked on, to obtain the correct harvest cycle pressure range).

## Diagnosing Air-Cooled Condensing Units

### FREEZE CYCLE

1. Determine the air temperature entering the remote condenser.
2. Determine if the head pressure is high or low in relationship to the outside temperature. (Refer to the proper "Operational Pressure Charts page 231.") If the air temperature is below 70°F (21.1°C), the head pressure control will modulate to maintain the correct liquid line temperature and head pressure.
3. Determine the temperature of the liquid line entering the receiver by feeling it. This line is normally warm – "body temperature."
4. Using the information gathered, refer to the list for diagnosis.

NOTE: A headmaster that will not bypass will function properly with condenser air temperatures of approximately 70°F (21.1°C) or above. When the temperature drops below 70°F (21.1°C), the headmaster fails to bypass and the ice machine malfunctions. Rinsing the condenser with cool water during the Freeze cycle will simulate lower ambient conditions.

<b>Condition</b>	<b>Probable Cause</b>	<b>Corrective Measure</b>
Discharge Pressure - High Liquid Line Temperature - Hot	Valve stuck in bypass	Replace valve
Discharge Pressure - Low Liquid Line Temperature - Cold	Valve not bypassing	Replace valve
Discharge Pressure - Low Liquid Line Temperature - Hot	Ice Machine Low on Charge	Low on Charge Verification

## HARVEST CYCLE

The headmaster control valve diverts the compressor discharge gas to the ice machine receiver in the harvest cycle. All refrigerant flow through the condenser in the harvest cycle stops. Symptoms of a headmaster valve that will not seat 100% closed (completely bypass the condenser) in the harvest cycle are:

- Freeze cycle suction and discharge pressure are normal.
- The control board indicates safety limit #2. The failure seems to be temperature related. Example: The ice machine may function correctly at temperatures above 32°F but fails at temperatures below 32°F.
- Harvest cycle suction pressure is low.
- Harvest cycle discharge pressure is normal or slightly low.

### Procedure

1. Freeze cycle operation must be normal before diagnosing the headmaster in the harvest cycle. (Refer to Cycle Times/24 hr Ice Production/ Refrigerant Pressure Chart)
2. Allow the ice machine to run a normal freeze cycle (do not initiate an early harvest cycle).
3. At the start of the harvest cycle feel the compressor discharge line and the liquid line to the ice machine receiver at the headmaster valve. The temperature of both lines will be highest at the beginning of the harvest cycle and then decrease. Compare the lines 30 seconds into the harvest cycle and then refer to Harvest Cycle Headmaster Control Valve Failure List page 205.

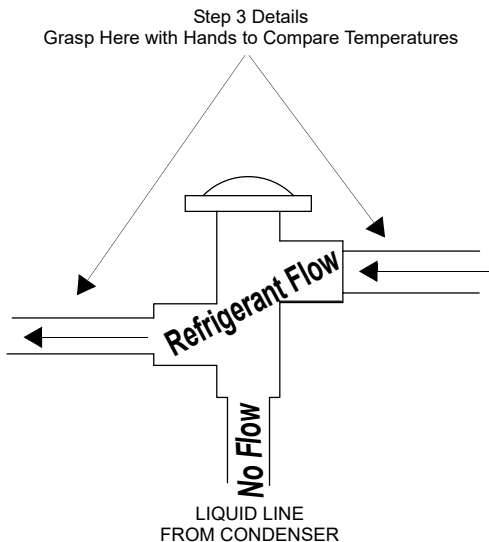

### HARVEST CYCLE HEADMASTER CONTROL VALVE FAILURE LIST

***Temperature of the compressor discharge line and liquid line to the ice machine receiver feel the same 30 seconds into the harvest cycle.***

- The headmaster is functioning correctly.

***The compressor discharge line is noticeably warmer than the liquid line to the ice machine receiver.***

- Headmaster valve is not bypassing 100%.  
Replace headmaster valve.

## **HEADMASTER VALVE WATER-COOLED CONDENSING UNIT - CVD1476**

### **Freeze Cycle**

The water regulating valve setting is higher than the head pressure control valve set point. All refrigerant is directed through the condenser and the water regulating valve maintains the correct head pressure.

### **Harvest Cycle**

The headmaster control valve diverts the compressor discharge gas to the ice machine receiver in the harvest cycle. All refrigerant flow through the condenser in the harvest cycle stops. Symptoms of a headmaster valve that will not seat 100% closed in the harvest cycle (completely bypass the condenser) are:

- Freeze cycle suction and discharge pressure are normal.
- The control board indicates safety limit #2.
- Harvest cycle suction pressure is low.
- Harvest cycle discharge pressure is normal or high (water regulating valve attempts to maintain 240 psig).

**CVD1476 Headmaster Control Valve Failure List**

<b>Condition</b>	<b>Probable Cause</b>	<b>Corrective Measure</b>
Discharge Pressure - Low Liquid Line Temperature - Hot	Ice Machine Low on Charge	Low on Charge Verification
Freeze Cycle Discharge Pressure - High or Freeze Cycle Discharge Pressure - Low	Water regulating valve maintains freeze cycle discharge pressure	Adjust or replace water regulating valve
Discharge Pressure - High Liquid Line Temperature - Hot	Verify water regulating valve is set and/or operating correctly. - Headmaster valve is stuck in bypass if water regulating valve is OK	Replace headmaster valve
Discharge Pressure - normal or high Liquid Line Temperature - Warm Suction Pressure - Low	Headmaster Valve not bypassing	Replace headmaster valve

## **WATER REGULATING VALVE CVD1476**

### **FUNCTION**

The water regulating valve maintains the freeze cycle discharge pressure. The valve setting for the CVD1486 condensing unit is 240 psig.

### **CHECK PROCEDURE**

1. Determine if the head pressure is high or low (refer to "Operational Pressure Charts" beginning on page 231).
2. Verify the condenser water meets specifications.
3. Adjust valve to increase or decrease discharge pressure (if discharge pressure remains high refer to "Headmaster Control Valve Diagnostics" page 205 before replacing valve).
4. Determine the temperature of the liquid line entering the receiver by feeling it. This line is normally warm; "body temperature."
5. Using the information gathered, refer to the list for diagnosis.

### ***Problem (Freeze Cycle)***

#### ***Valve not maintaining discharge pressure.***

- Valve incorrectly set, dirty or defective. Adjust valve to 240 psig, clean or replace valve.

#### ***Discharge pressure extremely high; Liquid line entering receiver feels hot.***

- Water regulating valve incorrectly set or not opening. Verify Head Pressure Control Valve operation before changing water regulating valve.

#### ***Discharge pressure low, Liquid line entering receiver feels warm to hot.***

- Ice machine low on charge. Refer to "Refrigerant Charge Verification."

## FAN CYCLE CONTROL

### FUNCTION

Energizes and de-energizes the condenser fan motor. The condenser fan motor typically will be on in the Freeze cycle and off in the Harvest cycle.

The fan cycle control closes on an increase, and opens on a decrease in discharge pressure.

Specifications	
Cut-In (Close)	Cut-Out (Open)
First Condenser Fan 250 psig $\pm$ 5	200 psig $\pm$ 5
Second Condenser Fan 275 psig $\pm$ 5	225 psig $\pm$ 5

### CHECK PROCEDURE

1. Verify fan motor windings are not open or grounded, and fan spins freely.
2. Connect manifold gauge set to ice machine.
3. Hook voltmeter in parallel across the fan cycle control, leaving wires attached.
4. Refer to chart below.

FCC Setpoint:	Reading Should Be:	Fan Should Be:
Above Cut-In	0 Volts	Running
Below Cut-Out	Line Voltage	Off

## **HIGH PRESSURE CUTOUT (HPCO) CONTROL FUNCTION**

Stops the ice machine if subjected to excessive high-side pressure.

The HPCO control is normally closed, and opens on a rise in discharge pressure.

<b>Specifications</b>	
<b>Cut-Out</b>	<b>Cut-In</b>
450 psig $\pm$ 10	Automatic Reset
(Must be below 300 psig to reset)	

### **CHECK PROCEDURE**

1. Set ICE/OFF/CLEAN switch to OFF.
2. Disconnect power to condensing unit.
3. Connect manifold gauge set on condensing unit access valves.
4. Hook voltmeter in parallel across the HPCO, leaving wires attached.
5. Reconnect condensing unit.
6. Set ICE/OFF/CLEAN switch to ICE, block condensing unit with cardboard or similar object.
7. No air flowing through the condenser will cause the HPCO control to open because of excessive pressure. Watch the pressure gauge and record the cut-out pressure.



### **Warning**

If discharge pressure exceeds 460 psig and the HPCO control does not cut out, set ICE/OFF/CLEAN switch to OFF to stop ice machine operation.

Replace the HPCO control if it:

1. Will not reset (below 300 psig).
2. Does not open at the specified cut-out point.

## **LOW PRESSURE CUTOUT (LPCO) CONTROL FUNCTION**

Energizes and de-energizes the contactor coil when suction pressure rises above or falls below setpoint.

The LPCO control is closed at pressures above setpoint and opens at pressures below setpoint.

	<b>Specifications</b>	
	<b>Cut-Out</b>	<b>Cut-In</b>
Original	7 psig $\pm$ 3	22 psig $\pm$ 3
Late Production & Replacement Part	12 psig $\pm$ 3	35 psig $\pm$ 3

## **CHECK PROCEDURE**

1. Connect manifold gauge set at suction and discharge access valves at the condensing unit.
2. Set ICE/OFF/CLEAN switch to OFF.
3. The liquid line solenoid valve will de-energize and the suction pressure will begin to decrease. The low-pressure control will open at the listed specification.
4. Use the manifold gauge set to increase suction pressure. Feed refrigerant from the high side access valve to the low side access valve. Add refrigerant in small increments to allow the low side pressure to be monitored. The low pressure control will close at the listed specification.

Replace the LPCO control if it:

1. Will not close at the specified setpoint.
2. Does not open at the specified setpoint.

## Refrigerant Recovery/Evacuation

Do not purge refrigerant to the atmosphere. Capture refrigerant using recovery equipment. Follow the manufacturer's recommendations.

### Important

Manitowoc Ice assumes no responsibility for the use of contaminated refrigerant. Damage resulting from the use of contaminated refrigerant is the sole responsibility of the servicing company.

### Important

Replace the liquid line drier before evacuating and recharging. Use only a Manitowoc (OEM) liquid line filter-drier to prevent voiding the warranty.



### Warning

Recovery/evacuation of a QuietQube® remote system requires connections at either three or five points for complete system recovery/evacuation. Check valves are located in the ice machine head section on all models and in the CVD condensing unit on models manufactured in 2010 and beyond. Three point connections are - receiver service valve, suction line and liquid line - Five point requires another connection between the compressor and suction filter access valves to recover and evacuate the entire system.



### Warning

The receiver access valve (located in the ice machine head section) must be accessed during refrigerant recovery to allow complete removal of the refrigerant charge.

## CONNECTIONS

Manifold gauge sets must utilize low loss fittings to comply with U.S. Government rules and regulations.

All CVD condensing units are now manufactured with a check valve in the compressor discharge line. The check valve requires an additional connection on the condensing unit during evacuation and recovery procedures. **Connection of a manifold gauge set (or a hose with core depressors on both ends) between the suction filter access port and the compressor access valve (located between the compressor and discharge line check valve) is required.**

Make these connections:

### Ice Machine Head Section - All Models

1. Suction side of the compressor through the suction shut-off valve or suction access valve.
2. Discharge side of the compressor through the liquid line shut-off valve or high side access valve.
3. Receiver access valve, (both receiver service valves on S3070C/SF3000C = fastest recovery time) which evacuates the area between the check valve in the liquid line and the liquid line solenoid valve.

### CVD Condensing Unit - Started In 2010

4. Compressor discharge access valve
5. Suction filter access valve.

#### **Warning**

Recovery/evacuation of a QuietQube® remote system requires connections at either three, five or six points for complete system recovery/evacuation. Check valves are located in the ice machine head section on all models and in the CVD condensing unit on models manufactured in 2010 and beyond. Three point connections are - receiver service valve, suction line and liquid line - Five point requires another connection between the compressor and suction filter access valves to recover and evacuate the entire system.

**Warning**

The receiver access valve (located in the ice machine head section) must be accessed during refrigerant recovery to allow complete removal of the refrigerant charge.

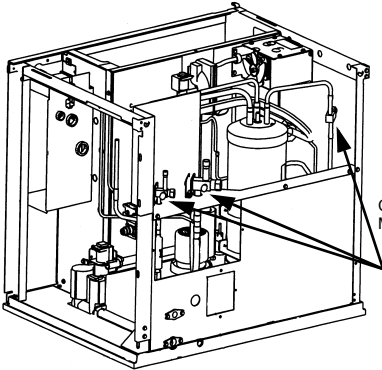

CONNECTIONS MUST BE MADE AT THREE POINTS FOR COMPLETE REFRIGERANT RECOVERY ON ALL QUIETQUBE® MODELS.

**Refrigerant Recovery Connections Ice Machine Head**

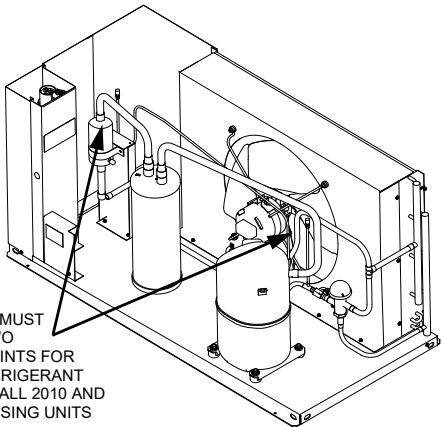

CONNECTIONS MUST BE MADE AT TWO ADDITIONAL POINTS FOR COMPLETE REFRIGERANT RECOVERY ON ALL 2010 AND LATER CONDENSING UNITS

**Refrigerant Recovery Connections CVD Condensing Unit**

## **RECOVERY/EVACUATION PROCEDURES**

1. Place the ICE/OFF/CLEAN toggle switch in the OFF position and disconnect all power to the ice machine and condensing unit.
2. Install manifold gauge set, charging scale, and recovery unit or two-stage vacuum pump.
3. Open the receiver service valve halfway.
4. Open high and low side on the manifold gauge set.
5. Perform recovery or evacuation:
  - A. Recovery: Operate the recovery unit as directed by the manufacturer's instructions.
  - B. Pressure test the system.
  - C. Evacuation prior to recharging: Evacuate to 500 microns. Then allow the pump to run for an additional hour.
6. Refer to Charging Procedures.

## CHARGING PROCEDURES

1. Verify the ICE/OFF/CLEAN toggle switch is in the OFF position.
2. Close the vacuum pump valve and the low side manifold gauge valve.
3. Open the refrigerant cylinder and add the proper refrigerant charge (shown on nameplate) into the system high side (receiver service valve and discharge line shut-off valve).
4. If the high side does not take the entire charge, close the high side on the manifold gauge set. Start the ice machine and add the remaining charge through valves on back of ice making head, or through valves on suction filter.
5. Run the ice machine in the Freeze cycle.
6. Close the receiver service valve in the ice machine head section.
7. Disconnect the manifold gauge set from the liquid line shut-off valve.
8. Open the high and low side valves on the manifold gauge set. Any refrigerant in the lines will be pulled into the low side of the system.
9. Allow the pressures to equalize while the ice machine is in the Freeze cycle.
10. Disconnect the manifold gauge set from the suction line shut-off valve.
11. Install and torque all valve caps

NOTE: Check for refrigerant leaks after all valve caps have been installed.

# System Contamination Cleanup

## General

This section describes the basic requirements for restoring contaminated systems to reliable service.

### Important

Manitowoc Ice assumes no responsibility for the use of contaminated refrigerant. Damage resulting from the use of contaminated refrigerant is the sole responsibility of the servicing company.

## DETERMINING SEVERITY OF CONTAMINATION

System contamination is generally caused by either moisture or residue from compressor burnout entering the refrigeration system.

Inspection of the refrigerant usually provides the first indication of system contamination. Obvious moisture or an acrid odor in the refrigerant indicates contamination.

If either condition is found, or if contamination is suspected, use a Total Test Kit from Totaline or a similar diagnostic tool. These devices sample refrigerant, eliminating the need to take an oil sample. Follow the manufacturer's directions.

If a refrigerant test kit indicates harmful levels of contamination, or if a test kit is not available, inspect the compressor oil.

1. Remove the refrigerant charge from the ice machine.
2. Remove the compressor from the system.
3. Check the odor and appearance of the oil.
4. Inspect open suction and discharge lines at the compressor for burnout deposits.
5. If no signs of contamination are present, perform an acid oil test to determine the type of cleanup required.

**NOTE: Manitowoc Service procedures require re-use of the refrigerant if the quality has not been compromised.**

<b>Contamination Cleanup Chart</b>	
<b>Symptoms/Findings</b>	<b>Required Cleanup Procedure</b>
No symptoms or suspicion of contamination	Normal evacuation/recharging procedure
Moisture/Air Contamination symptoms Refrigeration system open to atmosphere for longer than 15 minutes Refrigeration test kit and/or acid oil test shows contamination No burnout deposits in open compressor lines	Mild contamination cleanup procedure
Mild Compressor Burnout symptoms Oil appears clean but smells acrid Refrigeration test kit or acid oil test shows harmful acid content No burnout deposits in open compressor lines	Severe contamination cleanup procedure
Severe Compressor Burnout symptoms Oil is discolored, acidic, and smells acrid Burnout deposits found in the compressor, lines, and other components	Severe contamination cleanup procedure

## CLEANUP PROCEDURE

### Mild System Contamination

1. Replace any failed components.
2. If the compressor is good, change the oil.
3. Replace the liquid line drier and suction filter.

NOTE: If the contamination is from moisture, use heat lamps during evacuation. Position them at the compressor, condenser and evaporator prior to evacuation. Do not position heat lamps too close to plastic components, or they may melt or warp.

#### **Important**

Dry nitrogen is recommended for this procedure. This will prevent CFC release.

4. Follow the normal evacuation procedure, except replace the evacuation step with the following:
  - A. Pull vacuum to 1000 microns. Break the vacuum with dry nitrogen and sweep the system. Pressurize to a minimum of 5 psig.
  - B. Pull vacuum to 500 microns. Break the vacuum with dry nitrogen and sweep the system. Pressurize to a minimum of 5 psig.
  - C. Change the vacuum pump oil.
  - D. Pull vacuum to 250 microns. Run the vacuum pump for 1/2 hour on self-contained models, 1 hour on remotes.

NOTE: You may perform a pressure test as a preliminary leak check. You should use an electronic leak detector after system charging to be sure there are no leaks.

5. Charge the system with the proper refrigerant to the nameplate charge.
6. Operate the ice machine.

## Severe System Contamination

1. Remove the refrigerant charge.
2. Remove the compressor.
3. Cut copper tubing at the outlet of the harvest valve. If burnout deposits are found inside the tubing, replace the harvest valve, TXV and head pressure control valve.
4. Wipe away any burnout deposits from suction and discharge lines at compressor.
5. Sweep through the open system with dry nitrogen.

### Important

Refrigerant sweeps are not recommended, as they release CFCs into the atmosphere.

6. Install a new compressor and new start components.
7. Replace existing suction line filter.
8. Install a suction line filter-drier.
9. Install a new liquid line drier.
10. Follow the normal evacuation procedure, except replace the evacuation step with the following:
  - A. Pull vacuum to 1000 microns. Break the vacuum with dry nitrogen and sweep the system. Pressurize to a minimum of 5 psig.
  - B. Change the vacuum pump oil.
  - C. Pull vacuum to 500 microns. Break the vacuum with dry nitrogen and sweep the system. Pressurize to a minimum of 5 psig.
  - D. Change the vacuum pump oil.
  - E. Pull vacuum to 250 microns. Run the vacuum pump for 1 hour additional.

11. Charge the system with the proper refrigerant to the nameplate charge.
12. Operate the ice machine for one hour. Then, check the pressure drop across the suction line filter-drier.
  - A. If the pressure drop is less than 2 psig, the filter-drier should be adequate for complete cleanup.
  - B. If the pressure drop exceeds 2 psig, change the suction line filter-drier and the liquid line drier. Repeat until the pressure drop is acceptable.
13. Operate the ice machine for 48-72 hours. Then remove the suction line drier, replace with suction filter and change the liquid line drier.
14. Follow normal evacuation procedures.

## Replacing Pressure Controls Without Removing Refrigerant Charge

This procedure reduces repair time and cost. Use it when any of the following components require replacement, and the refrigeration system is operational and leak-free.

- Fan cycle control
- High pressure cut-out control
- Low pressure cut-out control
- High side condensing unit access valve

### Important

This is a required in-warranty repair procedure.

1. Disconnect power to the ice machine.
2. Follow all manufacturer's instructions supplied with the pinch-off tool. Position the pinch-off tool around the tubing as far from the pressure control as feasible. (See the figure on next page.) Clamp down on the tubing until the pinch-off is complete.



### Warning

Do not unsolder a defective component. Cut it out of the system. Do not remove the pinch-off tool until the new component is securely in place.

3. Cut the tubing of the defective component with a small tubing cutter.
4. Solder the replacement component in place. Allow the solder joint to cool.
5. Remove the pinch-off tool.
6. Re-round the tubing. Position the flattened tubing in the proper hole in the pinch-off tool. Tighten the wing nuts until the block is tight and the tubing is rounded.

NOTE: The pressure controls will operate normally once the tubing is re-rounded. Tubing may not re-round 100%.

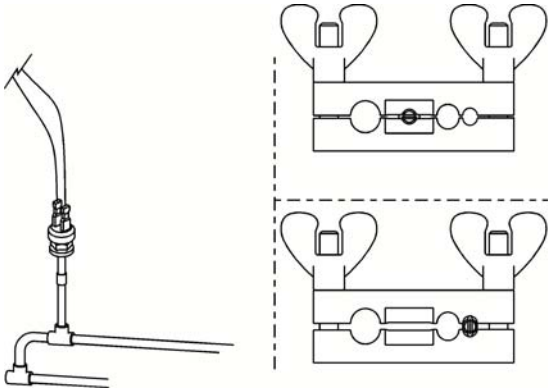

SV1406

**USING PINCH-OFF TOOL**

## Refrigerant Reuse Policy

Manitowoc recognizes and supports the need for proper handling, reuse, and disposal of CFC and HCFC refrigerants. Manitowoc service procedures require recapturing refrigerants, not venting them to the atmosphere.

It is not necessary, in or out of warranty, to reduce or compromise the quality and reliability of your customers' products to achieve this.

### Important

Manitowoc Ice assumes no responsibility for use of contaminated refrigerant. Damage resulting from the use of contaminated, recovered, or recycled refrigerant is the sole responsibility of the servicing company.

Manitowoc approves the use of:

#### 1. **New Refrigerant**

- Must be of original nameplate type.

#### 2. **Reclaimed Refrigerant**

- Must be of original nameplate type.
- Must meet ARI Standard 700 (latest edition) specifications.

#### 3. **Recovered or Recycled Refrigerant**

- Must be recovered or recycled in accordance with current local, state and federal laws.
- Must be recovered from and reused in the same Manitowoc product. Reuse of recovered or recycled refrigerant from other products is not approved.
- Recycling equipment must be certified to ARI Standard 740 (latest edition) and be maintained to consistently meet this standard.

- Recovered refrigerant must come from a “contaminant-free” system. To decide whether the system is contaminant-free, consider:
  - Types) of previous failure(s)
  - Whether the system was cleaned, evacuated and recharged properly following failure(s)
  - Whether the system has been contaminated by this failure
- Compressor motor burnouts and improper past service prevent refrigerant reuse.
- Refer to “System Contamination Cleanup” page 216 to test for contamination.
- 4. **“Substitute” or “Alternative” Refrigerant**
  - Must use only Manitowoc-approved alternative refrigerants.
  - Must follow Manitowoc-published conversion procedures.

# Component Specifications

---

## **MAIN FUSE**

The main control board fuse is 250 Volt, 7 amp.

## **BIN SWITCH**

The bin switch is a magnetically operated reed switch. The magnet is attached to the lower right corner of the water curtain. The switch is attached to the right bulkhead wall.

The bin switch is connected to a varying D.C. voltage circuit. (Voltage does not remain constant.)

NOTE: Because of a wide variation in D.C. voltage, it is not recommended that a voltmeter be used to check bin switch operation.

## **HARVEST ASSIST AIR PUMP**

115 Volt or 230 Volt - matches the ice machine voltage.

## **ICE/OFF/CLEAN TOGGLE SWITCH**

### **S Model Ice Machines**

Single-pole, double-throw switch. The switch is connected into a varying low D.C. voltage circuit.

### **IB Model Ice Machines**

Double-pole, double-throw switch. The switch is connected into a varying low D.C. voltage circuit.

## **ELECTRONIC BIN THERMOSTAT CONTROL**

Setpoint Range: -30 to 212°F (-34 - 100°C)

## **WATER REGULATING VALVE**

The valve setting for the CVD1486 condensing unit is 240 psig.

## FAN CYCLE CONTROL

Specifications	
Cut-In (Close)	Cut-Out (Open)
First Condenser Fan 250 psig $\pm$ 5	200 psig $\pm$ 5
Second Condenser Fan 275 psig $\pm$ 5	225 psig $\pm$ 5

## HIGH PRESSURE CUTOUT (HPCO) CONTROL

Specifications	
Cut-Out	Cut-In
450 psig $\pm$ 10 (3103 kPa $\pm$ 69) 31 bar $\pm$ .69	Automatic Reset
(Must be below 300 psig {2068 kPa 20.68 bar} to reset.)	

## LOW PRESSURE CUTOUT (LPCO) CONTROL

	Specifications	
	Cut-Out	Cut-In
Original	7 psig $\pm$ 3	22 psig $\pm$ 3
Late Production & Replacement Part	12 psig $\pm$ 3	35 psig $\pm$ 3

## FILTER-DRIERS

### Liquid Line Filter-Drier

The filter-driers used on Manitowoc ice machines are manufactured to Manitowoc specifications.

The difference between a Manitowoc drier and an off-the-shelf drier is in filtration. A Manitowoc drier has dirt-retaining filtration, with filters on both the inlet and outlet ends. This is very important because ice machines have a back-flushing action that takes place during every Harvest cycle.

A Manitowoc filter-drier has a very high moisture removal capability and a good acid removal capacity.

Listed below is the recommended OEM field replacement drier:

Liquid Line Driers		
Model	Drier Size	End Connection Size
IB0600C IB0680C IB0800C IB1000C	DML-052S	1/4 in.
S0600C S0850C S1000C S1200C S1470C S1870C S2070C S2170C	DML-053S	3/8 in.
SF3000C S3300W	DML-084S	1/2"

### Important

The liquid line drier is covered as a warranty part. The liquid line drier must be replaced any time the system is opened for repair.

## Suction Line Filter

The suction filter traps particulate only and does not contain a desiccant. The filter needs replacement when:

1. The pressure drop across the drier exceeds 2 psig.
2. The total system refrigerant charge has escaped and the refrigeration system has been exposed to the atmosphere.
3. A compressor is replaced.
4. Refrigeration system contains contaminants.

Listed below is the recommended OEM field replacement filter:

<b>Suction Line Filter</b>			
<b>Model</b>	<b>Drier Size</b>	<b>End Connection Size</b>	<b>Part Number</b>
CVD0675 CVD0685 CVD0885	ASF35S5	5/8 in.	82-5053-9
CVD1075 CVD1085 CVD1185 CVD1285 CVD1485 CVD1486	ASF45S6	3/4 in.	82-5054-9
CVD2075 CVD2085 CVDF3000 CVD3085	ASF45S7	7/8 in.	82-5055-9

## TOTAL SYSTEM REFRIGERANT CHARGE

NOTE: All ice machines on this list are charged using R-404A refrigerant. This information is for reference only. Refer to the ice machine serial number tag to verify the system charge. Serial plate information overrides information listed in this table.

Model	Condensing Unit	Refrigerant Charge	Line Set Length
S0600C S0680C IB0600C IB0680C	CVD0675 CVD0685	11 lbs. 5 kg.	0-100 ft. 0-30 M
S0850C	CVD0885	11 lbs. 5 kg.	0-50 ft. 0-15 M
		12 lbs. 5.44 kg	51-100 ft. 15-30 M
IB0800C	CVD885	12 lbs. 192 oz.	0-100 ft. 0-30 M
S1000C	CVD1085	11 lbs. 5 kg	0-50 ft. 0-15 M
		12 lbs 5.44 kg	51-100 ft. 15-30 M
IB1000C	CVD1185 CVD1285 CVD1085 CVD1075	12 lbs. 192 oz.	0-100 ft. 0-30 M
S1200C	CVD1285	11 lbs. 5 kg	0-50 ft. 0-15 M
		12 lbs 5.44 kg	51-100 ft. 15-30 M
S1470C	CVD1485	12.75 lbs 5.44 kg	0-100 ft. 0-30 M
	CVD1486	12.75 lbs 5.44 kg	0-100 ft. 0-30 M
S1870C	CVD1885	15.0 lbs 6.8 kg	0-100 ft. 0-30 M
S2070C	CVD2075	15.0 lbs 6.8 kg	0-50 ft. 0-15 M
		21.0 lbs 8.0 kg	51-100 ft. 15-30 M
S2170C	CVD2085	18.0 lbs 8.2 kg	0-50 ft. 0-15 M
		22.0 lbs 10.0 kg	51-100 ft. 15-30 M

<b>Model</b>	<b>Condensing Unit</b>	<b>Refrigerant Charge</b>	<b>Line Set Length</b>
S3070C	CVD3085	20.0 lbs 9.1 kg	0-50 ft. 0-15 M
		23.0 lbs 10.4 kg	51-100 ft. 15-30 M
SF3000C	CVD3085	20.0 lbs 9.1 kg	0-50 ft. 0-15 M
		23.0 lbs 10.4 kg	51-100 ft. 15-30 M

## Charts

---

### **Cycle Times/24-Hour Ice Production/ Refrigerant Pressure**

These charts are used as guidelines to verify correct ice machine operation.

Accurate collection of data is essential to obtain the correct diagnosis.

- Ice production checks that are within 10% of the chart are considered normal. This is due to variances in water and air temperature. Actual temperatures will seldom match the chart exactly.
- Zero out manifold gauge set before obtaining pressure readings to avoid mis-diagnosis.
- All pressure readings are taken at the ice machine head section. Connect Manifold gauge set at the suction and liquid line shut-off valves to obtain pressure readings. Pressures taken at the condensing unit will vary with line set length, ambient, exposed line set etc. and will not match the published pressures. Do not use the receiver service valve to obtain high side pressures.
- Discharge and suction pressure are highest at the beginning of the cycle. Suction pressure will drop throughout the cycle. Verify the pressures are within the range indicated.
- During low ambient conditions, it is normal for the head pressure control valve to hunt (fluctuate up and down) on CVD condensing units. Hunting varies by model and ambient temperature, but generally settles out within the first 6 minutes of the freeze cycle.

## S0600C/CVD0675 SERIES REMOTE AIR COOLED

NOTE: These characteristics may vary depending on operating conditions.

### CYCLE TIMES

Freeze Time + Harvest Time = Cycle Time				
Air Temp. Entering Condenser °F/°C	Freeze Time			Harvest Time
	Water Temperature °F/°C			
	50/10	70/21	90/32	
-20 to 70/ -29 to 21	7.6-9.0	8.4-9.9	9.1-10.7	<b>.75-2.5</b>
80/27	7.8-9.2	8.6-10.1	9.3-10.9	
90/32	7.9-9.4	8.8-10.3	9.7-11.4	
100/38	8.6-10.1	9.4-11.2	10.2-11.9	
110/43	9.5-10.9	10.6-12.5	11.4-13.4	

<sup>1</sup>Times in minutes.

### 24-HOUR ICE PRODUCTION

Air Temp. Entering Condenser °F/°C	Water Temperature °F/°C		
	50/10	70/21	90/32
-20 to 70/ -29 to 21	650	600	560
80/27	640	590	550
90/32	630	580	530
100/38	590	540	510

<sup>1</sup>Based on average ice slab weight of 4.1-4.75 lb.

### OPERATING PRESSURES

Air Temp. Entering Condenser °F/°C	Freeze Cycle		Harvest Cycle	
	Discharge Pressure psig	Suction Pressure psig	Discharge Pressure psig	Suction Pressure psig
-20 to 50/ -29 to 10	200-250	44-26	180-210	65-85
70/21	235-255	50-28	185-210	65-90
80/27	245-275	50-28	190-210	75-100
90/32	250-290	52-30	195-215	75-105
100/38	270-320	52-31	210-240	80-110
110/43	300-360	60-32	215-260	85-115

## SD0682C/CVD0685 SERIES REMOTE AIR COOLED

NOTE: These characteristics may vary depending on operating conditions.

### CYCLE TIMES

Freeze Time + Harvest Time = Cycle Time				
Air Temp. Entering Condenser °F/°C	Freeze Time			Harvest Time
	Water Temperature °F/°C			
	50/10	70/21	90/32	
-20 to 70/ -29 to 21	8.7-10.0	9.5-11.0	10.9-12.5	<b>.75-2.5</b>
90/32	9.1-10.5	10.0-11.5	11.0-12.6	
100/38	9.7-11.2	10.8-12.4	11.9-13.6	
110/43	10.7-12.2	11.9-13.6	13.2-15.1	

<sup>1</sup>Times in minutes.

### 24-HOUR ICE PRODUCTION

Air Temp. Entering Condenser °F/°C	Water Temperature °F/°C		
	50/10	70/21	90/32
-20 to 70/ -29 to 21	650	600	535
90/32	625	575	530
100/38	590	540	495
110/43	545	495	450

<sup>1</sup>Based on average ice slab weight of 4.6-5.2 lb.

### OPERATING PRESSURES

Air Temp. Entering Condenser °F/°C	Freeze Cycle		Harvest Cycle	
	Discharge Pressure psig	Suction Pressure psig	Discharge Pressure psig	Suction Pressure psig
-20 to 50/ -29 to 10	200-250	44-26	180-210	65-85
70/21	235-255	50-28	185-210	65-90
80/27	245-275	50-28	190-210	75-100
90/32	250-290	52-30	195-215	75-105
100/38	270-320	52-31	210-240	80-110
110/43	300-360	60-32	215-260	85-115

## SY0684C/CVD0685 SERIES REMOTE AIR COOLED

NOTE: These characteristics may vary depending on operating conditions.

### CYCLE TIMES

Freeze Time + Harvest Time = Cycle Time				
Air Temp. Entering Condenser °F/°C	Freeze Time			Harvest Time
	Water Temperature °F/°C			
	50/10	70/21	90/32	
-20 to 70/ -29 to 21	8.2-9.5	9.0-10.4	9.7-11.2	.75-2.5
90/32	8.9-10.2	9.7-11.2	10.5-12.1	
100/38	9.5-11.0	10.5-12.1	11.5-13.2	
110/43	10.5-12.1	11.7-13.5	12.9-14.8	

<sup>1</sup>Times in minutes.

### 24-HOUR ICE PRODUCTION

Air Temp. Entering Condenser °F/°C	Water Temperature °F/°C		
	50/10	70/21	90/32
-20 to 70/ -29 to 21	680	630	590
90/32	640	590	550
100/38	600	550	510
110/43	550	500	460

<sup>1</sup>Based on average ice slab weight of 4.6-5.2 lb.

### OPERATING PRESSURES

Air Temp. Entering Condenser °F/°C	Freeze Cycle		Harvest Cycle	
	Discharge Pressure psig	Suction Pressure psig	Discharge Pressure psig	Suction Pressure psig
-20 to 50/ -29 to 10	200-250	44-26	180-210	65-85
70/21	235-255	50-28	185-210	65-90
80/27	245-275	50-28	190-210	75-100
90/32	250-290	52-30	195-215	75-105
100/38	270-320	52-31	210-240	80-110
110/43	300-360	60-32	215-260	85-115

## IB0600C/CVD675 SERIES REMOTE AIR COOLED

NOTE: These characteristics may vary depending on operating conditions.

### CYCLE TIMES

Freeze Time + Harvest Time = Cycle Time				
Air Temp. Entering Condenser °F/°C	Freeze Time			Harvest Time
	Water Temperature °F/°C			
	50/10	70/21	90/32	
-20 to 70/ -29 to 21	7.8-9.3	8.8-10.4	9.5-11.2	<b>.75-2.5</b>
80/27	8.0-9.4	8.9-10.5	9.7-11.4	
90/32	8.6-10.2	9.8-11.5	10.6-12.5	
100/38	9.7-11.4	11.0-12.9	12.0-14.0	

<sup>1</sup>Times in minutes.

### 24-HOUR ICE PRODUCTION

Air Temp. Entering Condenser °F/°C	Water Temperature °F/°C		
	50/10	70/21	90/32
-20 to 70/ -29 to 21	635	575	540
80/27	625	570	530
90/32	585	525	490
100/38	530	475	440

<sup>1</sup>Based on average ice slab weight of 4.1-4.75 lb.

### OPERATING PRESSURES

Air Temp. Entering Condenser °F/°C	Freeze Cycle		Harvest Cycle	
	Discharge Pressure psig	Suction Pressure psig	Discharge Pressure psig	Suction Pressure psig
-20 to 50/ -29 to 10	215-260	46-26	140-185	70-95
70/21	220-270	51-26	150-190	70-100
80/27	225-285	56-27	155-195	80-105
90/32	235-295	59-28	165-200	85-105
100/38	260-340	60-30	180-210	85-112
110/43	300-385	65-34	195-230	90-120

## IB0682DC/CVD685 SERIES REMOTE AIR COOLED

NOTE: These characteristics may vary depending on operating conditions.

### CYCLE TIMES

Freeze Time + Harvest Time = Cycle Time				
Air Temp. Entering Condenser °F/°C	Freeze Time			Harvest Time
	Water Temperature °F/°C			
	50/10	70/21	90/32	
-20 to 70/ -29 to 21	9.2-10.6	10.1-11.6	11.1-12.8	<b>.75-2.5</b>
90/32	9.5-11.0	10.5-12.1	11.6-13.3	
100/38	10.2-11.8	11.4-13.0	12.6-14.4	
110/43	11.2-12.9	12.6-14.4	14.1-16.1	

<sup>1</sup>Times in minutes.

### 24-HOUR ICE PRODUCTION

Air Temp. Entering Condenser °F/°C	Water Temperature °F/°C		
	50/10	70/21	90/32
-20 to 70/ -29 to 21	620	570	525
90/32	600	550	505
100/38	565	515	470
110/43	520	470	425

<sup>1</sup>Based on average ice slab weight of 4.6-5.2 lb.

### OPERATING PRESSURES

Air Temp. Entering Condenser °F/°C	Freeze Cycle		Harvest Cycle	
	Discharge Pressure psig	Suction Pressure psig	Discharge Pressure psig	Suction Pressure psig
-20 to 50/ -29 to 10	215-260	46-26	140-185	70-95
70/21	220-270	51-26	150-190	70-100
80/27	225-285	56-27	155-195	80-105
90/32	235-295	59-28	165-200	85-105
100/38	260-340	60-30	180-210	85-112
110/43	300-385	65-34	195-230	90-120

## IB0684YC/CVD685 SERIES REMOTE AIR COOLED

NOTE: These characteristics may vary depending on operating conditions.

### CYCLE TIMES

Freeze Time + Harvest Time = Cycle Time				
Air Temp. Entering Condenser °F/°C	Freeze Time			Harvest Time
	Water Temperature °F/°C			
	50/10	70/21	90/32	
-20 to 70/ -29 to 21	9.2-10.6	10.1-11.6	11.1-12.8	<b>.75-2.5</b>
90/32	9.5-11.0	10.5-12.1	11.6-13.3	
100/38	10.2-11.8	11.4-13.0	12.6-14.4	
110/43	11.2-12.9	12.6-14.4	14.1-16.1	

<sup>1</sup>Times in minutes.

### 24-HOUR ICE PRODUCTION

Air Temp. Entering Condenser °F/°C	Water Temperature °F/°C		
	50/10	70/21	90/32
-20 to 70/ -29 to 21	620	570	525
90/32	600	550	505
100/38	565	515	470
110/43	520	470	425

<sup>1</sup>Based on average ice slab weight of 4.6-5.2 lb.

### OPERATING PRESSURES

Air Temp. Entering Condenser °F/°C	Freeze Cycle		Harvest Cycle	
	Discharge Pressure psig	Suction Pressure psig	Discharge Pressure psig	Suction Pressure psig
-20 to 50/ -29 to 10	215-260	46-26	140-185	70-95
70/21	220-270	51-26	150-190	70-100
80/27	225-285	56-27	155-195	80-105
90/32	235-295	59-28	165-200	85-105
100/38	260-340	60-30	180-210	85-112
110/43	300-385	65-34	195-230	90-120

**SD0872C/SY0874C/CVD0885 SERIES  
REMOTE AIR COOLED  
MACHINES BEFORE SERIAL NUMBER 110682385**

NOTE: These characteristics may vary depending on operating conditions.

**CYCLE TIMES**

Freeze Time + Harvest Time = Cycle Time				
Air Temp. Entering Condenser °F/°C	Freeze Time			Harvest Time
	Water Temperature °F/°C			
	50/10	70/21	90/32	
-20 to 70/ -29 to 21	9.3-10.7	10.2-11.7	10.9-12.5	<b>.75-2.5</b>
80/27	9.4-10.8	10.3-11.9	11.0-12.7	
90/32	9.5-11.0	10.5-12.1	11.2-12.9	
100/38	10.0-11.5	11.0-12.7	13.6-15.5	
110/43	11.2-12.9	12.5-14.4	13.6-15.5	

<sup>1</sup>Times in minutes.

**24-HOUR ICE PRODUCTION**

Air Temp. Entering Condenser °F/°C	Water Temperature °F/°C		
	50/10	70/21	90/32
-20 to 70/ -29 to 21	770	710	670
80/27	760	700	660
90/32	750	690	650
100/38	720	660	620

<sup>1</sup>Based on average ice slab weight of 5.75-6.50 lb.

**OPERATING PRESSURES**

Air Temp. Entering Condenser °F/°C	Freeze Cycle		Harvest Cycle	
	Discharge Pressure psig	Suction Pressure psig	Discharge Pressure psig	Suction Pressure psig
-20 to 50/ -29 to 10	200-250	44-29	180-200	70-95
70/21	225-270	44-29	190-220	75-95
80/27	255-275	50-29	195-225	80-100
90/32	260-300	52-29	200-225	85-105
100/38	265-335	60-30	210-230	90-110
110/43	300-380	64-32	225-260	100-120

## SD0872C/CVD0885 SERIES REMOTE AIR COOLED MACHINES AFTER SERIAL NUMBER 110682385

NOTE: These characteristics may vary depending on operating conditions.

### CYCLE TIMES

Freeze Time + Harvest Time = Cycle Time				
Air Temp. Entering Condenser °F/°C	Freeze Time			Harvest Time
	Water Temperature °F/°C			
	50/10	70/21	90/32	
-20 to 70/ -29 to 21	8.7-10.0	9.6-11.1	10.7-12.3	<b>.75-2.5</b>
90/32	10.0-11.5	10.2-11.8	12.0-13.7	
100/38	10.9-12.5	11.7-13.5	12.8-14.6	
110/43	11.9-13.6	12.7-14.5	13.6-15.5	

<sup>1</sup>Times in minutes.

### 24-HOUR ICE PRODUCTION

Air Temp. Entering Condenser °F/°C	Water Temperature °F/°C		
	50/10	70/21	90/32
-20 to 70/ -29 to 21	815	745	680
90/32	720	705	615
100/38	670	625	580
110/43	620	585	550

<sup>1</sup>Based on average ice slab weight of 5.75-6.50 lb.

### OPERATING PRESSURES

Air Temp. Entering Condenser °F/°C	Freeze Cycle		Harvest Cycle	
	Discharge Pressure psig	Suction Pressure psig	Discharge Pressure psig	Suction Pressure psig
-20 to 50/ -29 to 10	200-250	50-30	170-200	65-75
70/21	250-290	60-30	180-210	75-95
80/27	260-300	60-31	190-220	75-95
90/32	270-310	60-33	200-230	80-100
100/38	300-380	80-34	210-250	90-110
110/43	310-390	80-35	220-260	105-130

## SY0874C/CVD0885 SERIES REMOTE AIR COOLED MACHINES AFTER SERIAL NUMBER 110682385

NOTE: These characteristics may vary depending on operating conditions.

### CYCLE TIMES

Freeze Time + Harvest Time = Cycle Time				
Air Temp. Entering Condenser °F/°C	Freeze Time			Harvest Time
	Water Temperature °F/°C			
	50/10	70/21	90/32	
-20 to 70/ -29 to 21	8.7-10.0	9.6-11.1	10.7-12.3	<b>.75-2.5</b>
90/32	10.0-11.5	10.2-11.8	12.0-13.7	
100/38	10.9-12.5	11.7-13.5	12.8-14.6	
110/43	11.9-13.6	12.7-14.5	13.6-15.5	

<sup>1</sup>Times in minutes.

### 24-HOUR ICE PRODUCTION

Air Temp. Entering Condenser °F/°C	Water Temperature °F/°C		
	50/10	70/21	90/32
-20 to 70/ -29 to 21	815	745	680
90/32	720	705	615
100/38	670	625	580
110/43	620	585	550

<sup>1</sup>Based on average ice slab weight of 5.75-6.50 lb.

### OPERATING PRESSURES

Air Temp. Entering Condenser °F/°C	Freeze Cycle		Harvest Cycle	
	Discharge Pressure psig	Suction Pressure psig	Discharge Pressure psig	Suction Pressure psig
-20 to 50/ -29 to 10	200-250	50-30	170-200	65-75
70/21	250-290	60-30	180-210	75-95
80/27	260-300	60-31	190-220	75-95
90/32	270-310	60-33	200-230	80-100
100/38	300-380	80-34	210-250	90-110
110/43	310-390	80-35	220-260	105-130

## IB0822DC/IB0824YC/CVD885 SERIES REMOTE AIR COOLED MACHINES BEFORE SERIAL NUMBER 110682385

NOTE: These characteristics may vary depending on operating conditions.

### CYCLE TIMES

Freeze Time + Harvest Time = Cycle Time				
Air Temp. Entering Condenser °F/°C	Freeze Time			Harvest Time
	Water Temperature °F/°C			
	50/10	70/21	90/32	
-20 to 70/ -29 to 21	9.4-10.8	10.5-12.1	11.4-13.1	<b>.75-2.5</b>
80/27	9.5-11.0	10.7-12.3	11.4-13.1	
90/32	10.3-11.9	11.2-12.9	12.1-13.8	
100/38	11.2-12.9	12.3-14.1	13.3-15.2	

<sup>1</sup>Times in minutes.

### 24-HOUR ICE PRODUCTION

Air Temp. Entering Condenser °F/°C	Water Temperature °F/°C		
	50/10	70/21	90/32
-20 to 70/ -29 to 21	760	690	640
80/27	750	680	640
90/32	700	650	610
100/38	650	600	560

<sup>1</sup>Based on average ice slab weight of 5.75-6.50 lb.

### OPERATING PRESSURES

Air Temp. Entering Condenser °F/°C	Freeze Cycle		Harvest Cycle	
	Discharge Pressure psig	Suction Pressure psig	Discharge Pressure psig	Suction Pressure psig
-20 to 50/ -29 to 10	215-260	46-22	140-185	70-95
70/21	220-270	40-23	150-190	70-100
80/27	225-285	47-24	155-195	80-95
90/32	235-295	52-25	165-200	85-100
100/38	260-340	56-26	180-210	85-112
110/43	300-385	60-28	195-230	90-115

## IB0822DC/CVD885 SERIES REMOTE AIR COOLED MACHINES AFTER SERIAL NUMBER 110682385

NOTE: These characteristics may vary depending on operating conditions.

### CYCLE TIMES

Freeze Time + Harvest Time = Cycle Time				
Air Temp. Entering Condenser °F/°C	Freeze Time			Harvest Time
	Water Temperature °F/°C			
	50/10	70/21	90/32	
-20 to 70/ -29 to 21	10.1-11.6	11.0-12.6	12.0-13.7	<b>.75-2.5</b>
<b>80/27</b>	11.3-13.0	11.6-13.4	13.3-15.2	
<b>90/32</b>	12.2-14.0	13.0-14.9	14.1-16.2	
<b>100/38</b>	13.0-14.9	14.0-16.0	14.9-17.0	

<sup>1</sup>Times in minutes.

### 24-HOUR ICE PRODUCTION

Air Temp. Entering Condenser °F/°C	Water Temperature °F/°C		
	50/10	70/21	90/32
-20 to 70/ -29 to 21	715	665	615
<b>90/32</b>	645	630	560
<b>100/38</b>	605	570	530
<b>110/43</b>	570	535	505

<sup>1</sup>Based on average ice slab weight of 5.75-6.50 lb.

### OPERATING PRESSURES

Air Temp. Entering Condenser °F/°C	Freeze Cycle		Harvest Cycle	
	Discharge Pressure psig	Suction Pressure psig	Discharge Pressure psig	Suction Pressure psig
-20 to 50/ -29 to 10	230-260	45-25	180-205	60-80
<b>70/21</b>	250-275	55-30	180-205	75-105
<b>80/27</b>	260-290	60-31	185-215	80-110
<b>90/32</b>	265-300	60-32	190-220	80-110
<b>100/38</b>	300-370	70-34	200-250	90-115
<b>110/43</b>	310-385	75-35	230-260	95-115

## IB0824YC/CVD885 SERIES REMOTE AIR COOLED MACHINES AFTER SERIAL NUMBER 110682385

NOTE: These characteristics may vary depending on operating conditions.

### CYCLE TIMES

Freeze Time + Harvest Time = Cycle Time				
Air Temp. Entering Condenser °F/°C	Freeze Time			Harvest Time
	Water Temperature °F/°C			
	50/10	70/21	90/32	
-20 to 70/ -29 to 21	8.9-10.3	9.8-11.2	10.9-12.5	<b>.75-2.5</b>
80/27	10.3-11.9	10.5-12.1	12.3-14.1	
90/32	11.1-12.8	12.1-13.8	13.0-14.9	
100/38	12.2-14.0	13.0-14.9	14.0-16.0	

<sup>1</sup>Times in minutes.

### 24-HOUR ICE PRODUCTION

Air Temp. Entering Condenser °F/°C	Water Temperature °F/°C		
	50/10	70/21	90/32
-20 to 70/ -29 to 21	795	735	670
90/32	700	690	600
100/38	655	610	570
110/43	605	570	535

<sup>1</sup>Based on average ice slab weight of 5.75-6.50 lb.

### OPERATING PRESSURES

Air Temp. Entering Condenser °F/°C	Freeze Cycle		Harvest Cycle	
	Discharge Pressure psig	Suction Pressure psig	Discharge Pressure psig	Suction Pressure psig
-20 to 50/ -29 to 10	230-260	45-25	180-205	60-80
70/21	250-275	55-30	180-205	75-105
80/27	260-290	60-31	185-215	80-110
90/32	265-300	60-32	190-220	80-110
100/38	300-370	70-34	200-250	90-115
110/43	310-385	75-35	230-260	95-115

## SD1072C/SY1074C/CVD1085 SERIES REMOTE AIR COOLED MACHINES BEFORE SERIAL NUMBER 110697654

NOTE: These characteristics may vary depending on operating conditions.

### CYCLE TIMES

Freeze Time + Harvest Time = Cycle Time				
Air Temp. Entering Condenser °F/°C	Freeze Time			Harvest Time
	Water Temperature °F/°C			
	50/10	70/21	90/32	
-20 to 70/ -29 to 21	7.0-8.1	7.7-8.1	8.0-9.3	<b>.75-2.5</b>
80/27	7.2-8.4	7.9-9.1	8.7-10.1	
90/32	7.5-8.7	8.2-9.5	9.1-10.5	
100/38	8.4-9.6	9.3-10.7	10.3-11.9	
110/43	9.4-10.8	10.5-12.1	11.9-13.6	

<sup>1</sup>Times in minutes.

### 24-HOUR ICE PRODUCTION

Air Temp. Entering Condenser °F/°C	Water Temperature °F/°C		
	50/10	70/21	90/32
-20 to 70/ -29 to 21	970	900	870
80/27	950	880	810
90/32	920	850	780
100/38	840	770	700

<sup>1</sup>Based on average ice slab weight of 5.75-6.5 lb.

### OPERATING PRESSURES

Air Temp. Entering Condenser °F/°C	Freeze Cycle		Harvest Cycle	
	Discharge Pressure psig	Suction Pressure psig	Discharge Pressure psig	Suction Pressure psig
-20 to 50/ -29 to 10	200-250	38-25	175-235	70-85
70/21	230-255	38-25	185-235	70-85
80/27	235-260	44-27	190-240	70-90
90/32	240-290	52-28	200-250	85-100
100/38	275-345	58-29	225-260	90-110
110/43	310-380	62-31	240-290	100-115

## SD1072C/CVD1085 SERIES REMOTE AIR COOLED MACHINES AFTER SERIAL NUMBER 110697654

NOTE: These characteristics may vary depending on operating conditions.

### CYCLE TIMES

Freeze Time + Harvest Time = Cycle Time				
Air Temp. Entering Condenser °F/°C	Freeze Time			Harvest Time
	Water Temperature °F/°C			
	50/10	70/21	90/32	
-20 to 70/ -29 to 21	7.5-8.7	8.1-9.3	8.8-10.1	<b>.75-2.5</b>
90/32	8.5-9.8	8.9-10.2	10.1-11.6	
100/38	9.2-10.6	10.0-11.5	10.9-12.5	
110/43	9.9-11.4	10.8-12.4	11.7-13.5	

<sup>1</sup>Times in minutes.

### 24-HOUR ICE PRODUCTION

Air Temp. Entering Condenser °F/°C	Water Temperature °F/°C		
	50/10	70/21	90/32
-20 to 70/ -29 to 21	920	865	805
80/27	825	800	715
90/32	775	720	670
100/38	725	675	625

<sup>1</sup>Based on average ice slab weight of 5.75-6.5 lb.

### OPERATING PRESSURES

Air Temp. Entering Condenser °F/°C	Freeze Cycle		Harvest Cycle	
	Discharge Pressure psig	Suction Pressure psig	Discharge Pressure psig	Suction Pressure psig
-20 to 50/ -29 to 10	200-250	40-30	170-210	70-85
70/21	230-255	50-30	185-220	70-90
80/27	235-260	50-30	190-225	70-95
90/32	240-290	55-31	200-240	85-105
100/38	275-345	60-32	220-260	90-115
110/43	310-380	65-32	240-280	100-120

During low ambient conditions, it is normal for the head pressure control valve to hunt (fluctuate up and down) on CVD condensing units. Hunting varies by model and ambient temperature, but generally settles out within the first 6 minutes of the freeze cycle.

## SY1074C/CVD1085 SERIES REMOTE AIR COOLED MACHINES AFTER SERIAL NUMBER 110697654

NOTE: These characteristics may vary depending on operating conditions.

### CYCLE TIMES

Freeze Time + Harvest Time = Cycle Time				
Air Temp. Entering Condenser °F/°C	Freeze Time			Harvest Time
	Water Temperature °F/°C			
	50/10	70/21	90/32	
-20 to 70/ -29 to 21	6.9-8.1	7.5-8.7	8.4-9.7	<b>.75-2.5</b>
90/32	8.0-9.2	8.2-9.5	9.5-11.0	
100/38	8.7-10.0	9.4-10.8	10.2-11.8	
110/43	9.4-10.8	10.2-11.7	11.0-12.6	

<sup>1</sup>Times in minutes.

### 24-HOUR ICE PRODUCTION

Air Temp. Entering Condenser °F/°C	Water Temperature °F/°C		
	50/10	70/21	90/32
-20 to 70/ -29 to 21	990	915	835
80/27	875	850	750
90/32	810	760	705
100/38	760	710	665

<sup>1</sup>Based on average ice slab weight of 5.75-6.5 lb.

### OPERATING PRESSURES

Air Temp. Entering Condenser °F/°C	Freeze Cycle		Harvest Cycle	
	Discharge Pressure psig	Suction Pressure psig	Discharge Pressure psig	Suction Pressure psig
-20 to 50/ -29 to 10	200-250	40-30	170-210	70-85
70/21	230-255	50-30	185-220	70-90
80/27	235-260	50-30	190-225	70-95
90/32	240-290	55-31	200-240	85-105
100/38	275-345	60-32	220-260	90-115
110/43	310-380	65-32	240-280	100-120

During low ambient conditions, it is normal for the head pressure control valve to hunt (fluctuate up and down) on CVD condensing units. Hunting varies by model and ambient temperature, but generally settles out within the first 6 minutes of the freeze cycle.

**IB1022DC/IB1024YC/CVD1075/CVD1085/CVD1285  
SERIES REMOTE AIR COOLED MACHINES  
BEFORE SERIAL NUMBER 110697294**

NOTE: These characteristics may vary depending on operating conditions.

**CYCLE TIMES**

Freeze Time + Harvest Time = Cycle Time				
Air Temp. Entering Condenser °F/°C	Freeze Time			Harvest Time
	Water Temperature °F/°C			
	50/10	70/21	90/32	
-20 to 70/ -29 to 21	9.9-10.6	10.8-11.6	11.8-12.6	<b>.75-2.5</b>
80/27	10.1-10.9	10.9-11.7	12.1-13.0	
90/32	10.6-11.4	11.5-12.3	12.8-13.7	
100/38	11.6-12.5	12.6-13.5	14.0-15.0	

<sup>1</sup>Times in minutes.

**24-HOUR ICE PRODUCTION**

Air Temp. Entering Condenser °F/°C	Water Temperature °F/°C		
	50/10	70/21	90/32
-20 to 70/ -29 to 21	980	910	840
80/27	960	900	820
90/32	920	860	780
100/38	850	790	720

<sup>1</sup>Based on average ice slab weight of 7.75-8.25 lb.

**OPERATING PRESSURES**

Air Temp. Entering Condenser °F/°C	Freeze Cycle		Harvest Cycle	
	Discharge Pressure psig	Suction Pressure psig	Discharge Pressure psig	Suction Pressure psig
-20 to 50/ -29 to 10	215-260	40-22	140-185	70-95
70/21	220-270	42-24	150-190	80-95
80/27	225-275	48-24	155-195	85-95
90/32	235-275	52-25	165-195	85-100
100/38	260-325	55-25	180-205	85-112
110/43	300-360	60-27	195-225	95-118

During low ambient conditions, it is normal for the head pressure control valve to hunt (fluctuate up and down) on CVD condensing units. Hunting varies by model and ambient temperature, but generally settles out within the first 6 minutes of the freeze cycle.

# IB1022DC/CVD1185 SERIES REMOTE AIR COOLED MACHINES AFTER SERIAL NUMBER 110697294

NOTE: These characteristics may vary depending on operating conditions.

## CYCLE TIMES

Freeze Time + Harvest Time = Cycle Time				
Air Temp. Entering Condenser °F/°C	Freeze Time			Harvest Time
	Water Temperature °F/°C			
	50/10	70/21	90/32	
-20 to 70/ -29 to 21	9.5-11.0	10.4-12.0	11.3-13.0	<b>.75-2.5</b>
90/32	10.3-11.9	10.6-12.3	12.2-14.0	
100/38	10.8-12.4	11.7-13.4	12.7-14.6	
110/43	11.2-12.9	12.2-14.0	13.3-15.3	

<sup>1</sup>Times in minutes.

## 24-HOUR ICE PRODUCTION

Air Temp. Entering Condenser °F/°C	Water Temperature °F/°C		
	50/10	70/21	90/32
-20 to 70/ -29 to 21	980	910	845
90/32	915	890	790
100/38	880	820	760
110/43	850	790	730

<sup>1</sup>Based on average ice slab weight of 7.5-8.5 lb.

## OPERATING PRESSURES

Air Temp. Entering Condenser °F/°C	Freeze Cycle		Harvest Cycle	
	Discharge Pressure psig	Suction Pressure psig	Discharge Pressure psig	Suction Pressure psig
-20 to 50/ -29 to 10	200-250	40-25	140-170	65-75
70/21	220-270	40-25	150-185	65-85
80/27	225-275	50-26	160-190	70-90
90/32	235-275	60-27	175-195	75-95
100/38	260-325	65-30	190-220	80-100
110/43	300-360	70-33	200-230	90-105

During low ambient conditions, it is normal for the head pressure control valve to hunt (fluctuate up and down) on CVD condensing units. Hunting varies by model and ambient temperature, but generally settles out within the first 6 minutes of the freeze cycle.

## IB1024YC/CVD1185 SERIES REMOTE AIR COOLED MACHINES AFTER SERIAL NUMBER 110697294

NOTE: These characteristics may vary depending on operating conditions.

### CYCLE TIMES

Freeze Time + Harvest Time = Cycle Time				
Air Temp. Entering Condenser °F/°C	Freeze Time			Harvest Time
	Water Temperature °F/°C			
	50/10	70/21	90/32	
-20 to 70/ -29 to 21	9.3-10.7	10.2-11.8	11.3-13.0	<b>.75-2.5</b>
90/32	10.5-12.1	10.6-12.3	12.5-14.4	
100/38	11.3-13.0	12.2-14.0	13.2-15.2	
110/43	12.0-13.8	13.0-14.9	13.6-15.6	

<sup>1</sup>Times in minutes.

### 24-HOUR ICE PRODUCTION

Air Temp. Entering Condenser °F/°C	Water Temperature °F/°C		
	50/10	70/21	90/32
-20 to 70/ -29 to 21	1000	920	845
90/32	900	890	770
100/38	845	790	735
110/43	800	745	715

<sup>1</sup>Based on average ice slab weight of 7.5-8.5 lb.

### OPERATING PRESSURES

Air Temp. Entering Condenser °F/°C	Freeze Cycle		Harvest Cycle	
	Discharge Pressure psig	Suction Pressure psig	Discharge Pressure psig	Suction Pressure psig
-20 to 50/ -29 to 10	200-250	40-25	140-170	65-75
70/21	220-270	40-25	150-185	65-85
80/27	225-275	50-26	160-190	70-90
90/32	235-275	60-27	175-195	75-95
100/38	260-325	65-30	190-220	80-100
110/43	300-360	70-33	200-230	90-105

During low ambient conditions, it is normal for the head pressure control valve to hunt (fluctuate up and down) on CVD condensing units. Hunting varies by model and ambient temperature, but generally settles out within the first 6 minutes of the freeze cycle.

## SD1272C/SY1274C/CVD1285 SERIES REMOTE AIR COOLED MACHINES BEFORE SERIAL NUMBER 110706336

NOTE: These characteristics may vary depending on operating conditions.

### CYCLE TIMES

Freeze Time + Harvest Time = Cycle Time				
Air Temp. Entering Condenser °F/°C	Freeze Time			Harvest Time
	Water Temperature °F/°C			
	50/10	70/21	90/32	
-20 to 70/ -29 to 21	8.0-8.9	9.0-10.0	9.9-11.0	<b>.75-2.5</b>
80/27	8.3-9.3	9.2-10.3	10.0-11.1	
90/32	8.6-9.6	9.3-10.4	10.4-11.6	
100/38	10.0-11.1	9.8-10.9	10.5-11.7	
110/43	10.2-11.4	10.8-12.0	12.0-13.4	

<sup>1</sup>Times in minutes.

### 24-HOUR ICE PRODUCTION

Air Temp. Entering Condenser °F/°C	Water Temperature °F/°C		
	50/10	70/21	90/32
-20 to 70/ -29 to 21	1140	1030	950
80/27	1100	1010	940
90/32	1070	1000	910
100/38	1010	960	900

<sup>1</sup>Based on average ice slab weight of 7.5-8.25 lb.

### OPERATING PRESSURES

Air Temp. Entering Condenser °F/°C	Freeze Cycle		Harvest Cycle	
	Discharge Pressure psig	Suction Pressure psig	Discharge Pressure psig	Suction Pressure psig
-20 to 50/ -29 to 10	200-250	38-25	160-175	70-85
70/21	245-265	38-26	165-180	70-90
80/27	245-275	40-27	165-180	75-95
90/32	260-285	41-28	170-190	85-100
100/38	265-345	42-28	180-200	90-100
110/43	300-360	43-28	190-210	100-115

## SD1272C/CVD1285 SERIES REMOTE AIR COOLED MACHINES AFTER SERIAL NUMBER 110706336

NOTE: These characteristics may vary depending on operating conditions.

### CYCLE TIMES

Freeze Time + Harvest Time = Cycle Time				
Air Temp. Entering Condenser °F/°C	Freeze Time			Harvest Time
	Water Temperature °F/°C			
	50/10	70/21	90/32	
-20 to 70/ -29 to 21	8.4-9.3	9.1-10.1	10.0-11.1	<b>.75-2.5</b>
<b>90/32</b>	9.3-10.4	9.6-10.7	11.0-12.2	
<b>100/38</b>	9.8-10.9	10.6-11.8	11.6-12.9	
<b>110/43</b>	10.4-11.6	11.3-12.6	12.3-13.6	

<sup>1</sup>Times in minutes.

### 24-HOUR ICE PRODUCTION

Air Temp. Entering Condenser °F/°C	Water Temperature °F/°C		
	50/10	70/21	90/32
-20 to 70/ -29 to 21	1095	1020	940
<b>90/32</b>	1000	975	865
<b>100/38</b>	955	890	825
<b>110/43</b>	905	845	785

<sup>1</sup>Based on average ice slab weight of 7.5-8.25 lb.

### OPERATING PRESSURES

Air Temp. Entering Condenser °F/°C	Freeze Cycle		Harvest Cycle	
	Discharge Pressure psig	Suction Pressure psig	Discharge Pressure psig	Suction Pressure psig
-20 to 50/ -29 to 10	190-250	40-22	160-175	65-80
<b>70/21</b>	230-250	45-23	165-190	70-90
<b>80/27</b>	245-275	45-26	165-190	70-95
<b>90/32</b>	245-282	50-28	180-200	70-95
<b>100/38</b>	265-345	52-28	180-200	90-100
<b>110/43</b>	300-360	55-28	200-220	85-110

## SY1274C/CVD1285 SERIES REMOTE AIR COOLED MACHINES AFTER SERIAL NUMBER 110706336

NOTE: These characteristics may vary depending on operating conditions.

### CYCLE TIMES

Freeze Time + Harvest Time = Cycle Time				
Air Temp. Entering Condenser °F/°C	Freeze Time			Harvest Time
	Water Temperature °F/°C			
	50/10	70/21	90/32	
-20 to 70/ -29 to 21	8.3-9.3	9.1-10.1	9.9-11.1	<b>.75-2.5</b>
90/32	9.1-10.2	9.3-10.4	10.8-12.0	
100/38	9.6-10.6	10.4-11.6	11.3-12.6	
110/43	10.1-11.3	10.9-12.2	11.8-13.2	

<sup>1</sup>Times in minutes.

### 24-HOUR ICE PRODUCTION

Air Temp. Entering Condenser °F/°C	Water Temperature °F/°C		
	50/10	70/21	90/32
-20 to 70/ -29 to 21	1100	1020	945
90/32	1015	1000	880
100/38	970	910	845
110/43	930	870	810

<sup>1</sup>Based on average ice slab weight of 7.5-8.25 lb.

### OPERATING PRESSURES

Air Temp. Entering Condenser °F/°C	Freeze Cycle		Harvest Cycle	
	Discharge Pressure psig	Suction Pressure psig	Discharge Pressure psig	Suction Pressure psig
-20 to 50/ -29 to 10	190-250	40-22	160-175	65-80
70/21	230-250	45-23	165-190	70-90
80/27	245-275	45-26	165-190	70-95
90/32	245-282	50-28	180-200	70-95
100/38	265-345	52-28	180-200	90-100
110/43	300-360	55-28	200-220	85-110

## S1470C/CVD1485 SERIES REMOTE AIR COOLED

NOTE: These characteristics may vary depending on operating conditions.

### CYCLE TIMES

Freeze Time + Harvest Time = Cycle Time				
Air Temp. Entering Condenser °F/°C	Freeze Time			Harvest Time
	Water Temperature °F/°C			
	50/10	70/21	90/32	
-20 to 70/ -29 to 21	10.8-12.9	11.8-14.0	12.9-15.3	<b>.75-2.5</b>
90/32	12.3-14.6	12.5-14.8	14.6-17.3	
100/38	13.3-15.7	14.4-17.0	15.6-18.5	
110/43	14.2-16.8	15.4-18.3	16.7-19.7	

<sup>1</sup>Times in minutes.

### 24-HOUR ICE PRODUCTION

Air Temp. Entering Condenser °F/°C	Water Temperature °F/°C		
	50/10	70/21	90/32
-20 to 70/ -29 to 21	1400	1300	1200
90/32	1250	1235	1075
100/38	1170	1090	1010
110/43	1100	1020	950

<sup>1</sup> Based on average ice weight of one Harvest cycle 12.0-14.0 lb. (6.0-7.0 lb. per evaporator).

### OPERATING PRESSURES

Air Temp. Entering Condenser °F/°C	Freeze Cycle		Harvest Cycle	
	Discharge Pressure psig	Suction Pressure psig	Discharge Pressure psig	Suction Pressure psig
-20 to 70/ -29 to 21	235-250	60-36	140-165	70-95
80/27	235-250	60-38	150-170	70-95
90/32	240-275	60-38	160-180	85-95
100/38	285-300	65-39	170-190	90-110
110/43	300-350	70-40	180-200	95-115
120/49	350-410	80-40	190-215	100-125
130/54	380-435	85-40	195-225	105-130

## S1470C/CVD1486 REMOTE WATER COOLED

NOTE: These characteristics may vary depending on operating conditions.

### CYCLE TIMES

Freeze Time + Harvest Time = Cycle Time				
Air Temp. Entering Condenser °F/°C	Freeze Time			Harvest Time
	Water Temperature °F/°C			
	50/10	70/21	90/32	
35 to 70/ 2 to 21	11.3-13.4	12.5-14.8	13.9-16.5	<b>.75-2.5</b>
80/27	11.3-13.4	12.5-14.8	14.0-16.6	
90/32	11.3-13.4	12.5-14.9	14.1-16.7	
100/38	11.3-13.4	12.5-14.9	14.1-16.7	

<sup>1</sup>Times in minutes.

### 24-HOUR ICE PRODUCTION

Air Temp. Around the Condenser °F/°C	Water Temperature °F/°C		
	50/10	70/21	90/32
35 to 70/ 2 to 21	1350	1235	1120
80/27	1350	1235	1115
90/32	1350	1230	1110
100/38	1350	1230	1110

<sup>1</sup> Based on average ice weight of one Harvest cycle 12.0-14.0 lb. (6.0-7.0 lb. per evaporator).

### OPERATING PRESSURES

Air Temp. Entering Condenser °F/°C	Freeze Cycle		Harvest Cycle	
	Discharge Pressure psig	Suction Pressure psig	Discharge Pressure psig	Suction Pressure psig
35 to 70/ 2 to 21	235-250	60-36	200-225	70-95
80/27	235-255	60-38	200-225	75-95
90/32	240-260	60-38	205-230	80-95
100/38	245-265	65-40	205-230	80-95
110/43	245-265	70-40	210-235	80-100

### CONDENSER WATER CONSUMPTION

Condenser Water Consumption	90/32 Air Temperature Around Ice Machine		
	Water Temp. °F/°C		
	50/10	70/21	90/32
Gal/24 Hours	950	1700	6000

## SD1872C/CVD1885 SERIES REMOTE AIR COOLED

NOTE: These characteristics may vary depending on operating conditions.

### CYCLE TIMES

Freeze Time + Harvest Time = Cycle Time				
Air Temp. Entering Condenser °F/°C	Freeze Time			Harvest Time
	Water Temperature °F/°C			
	50/10	70/21	90/32	
-20 to 70/ -29 to 21	11.1-13.1	12.0-13.1	13.1-14.3	<b>.75-2.5</b>
<b>90/32</b>	12.8-13.9	13.4-14.6	15.0-16.4	
<b>100/38</b>	13.8-15.0	14.9-16.2	16.2-17.6	
<b>110/43</b>	14.9-16.2	16.2-17.6	17.6-19.1	

<sup>1</sup>Times in minutes.

### 24-HOUR ICE PRODUCTION

Air Temp. Entering Condenser °F/°C	Water Temperature °F/°C		
	50/10	70/21	90/32
-20 to 70/ -29 to 21	1770	1650	1530
<b>90/32</b>	1565	1500	1350
<b>100/38</b>	1460	1360	1260
<b>110/43</b>	1360	1260	1170

<sup>1</sup> Based on average ice weight of one Harvest cycle 15.5-16.75 lb. (7.75-8.38 lb. per evaporator).

### OPERATING PRESSURES

Air Temp. Entering Condenser °F/°C	Freeze Cycle		Harvest Cycle	
	Discharge Pressure psig	Suction Pressure psig	Discharge Pressure psig	Suction Pressure psig
-20 to 70/ -29 to 21	215-250	60-30	140-155	65-90
<b>80/27</b>	215-260	60-33	140-155	65-90
<b>90/32</b>	240-280	60-34	145-165	65-95
<b>100/38</b>	250-295	60-35	150-170	65-95
<b>110/43</b>	290-365	60-36	160-190	75-100
<b>120/49</b>	300-380	60-37	170-200	80-110

During low ambient conditions, it is normal for the head pressure control valve to hunt (fluctuate up and down) on CVD condensing units. Hunting varies by model and ambient temperature, but generally settles out within the first 6 minutes of the freeze cycle

## SY1874C/CVD1885 SERIES REMOTE AIR COOLED

NOTE: These characteristics may vary depending on operating conditions.

### CYCLE TIMES

Freeze Time + Harvest Time = Cycle Time				
Air Temp. Entering Condenser °F/°C	Freeze Time			Harvest Time
	Water Temperature °F/°C			
	50/10	70/21	90/32	
-20 to 70/ -29 to 21	10.7-11.7	11.7-12.8	12.8-14.0	<b>.75-2.5</b>
90/32	12.2-13.3	12.9-14.1	14.7-16.0	
100/38	13.1-14.3	14.4-15.7	15.9-17.3	
110/43	14.2-15.5	15.6-17.0	17.2-18.7	

<sup>1</sup>Times in minutes.

### 24-HOUR ICE PRODUCTION

Air Temp. Entering Condenser °F/°C	Water Temperature °F/°C		
	50/10	70/21	90/32
-20 to 70/ -29 to 21	1825	1690	1560
90/32	1625	1550	1375
100/38	1525	1405	1285
110/43	1420	1305	1195

<sup>1</sup> Based on average ice weight of one Harvest cycle 15.5-16.75 lb. (7.75-8.38 lb. per evaporator).

### OPERATING PRESSURES

Air Temp. Entering Condenser °F/°C	Freeze Cycle		Harvest Cycle	
	Discharge Pressure psig	Suction Pressure psig	Discharge Pressure psig	Suction Pressure psig
-20 to 70/ -29 to 21	215-250	60-30	140-155	65-90
80/27	215-260	60-33	140-155	65-90
90/32	240-280	60-34	145-165	65-95
100/38	250-295	60-35	150-170	65-95
110/43	290-365	60-36	160-190	75-100
120/49	300-380	60-37	170-200	80-110

During low ambient conditions, it is normal for the head pressure control valve to hunt (fluctuate up and down) on CVD condensing units. Hunting varies by model and ambient temperature, but generally settles out within the first 6 minutes of the freeze cycle.

## SD2072C/CVD2075 SERIES REMOTE AIR COOLED

NOTE: These characteristics may vary depending on operating conditions.

### CYCLE TIMES

Freeze Time + Harvest Time = Cycle Time				
Air Temp. Entering Condenser °F/°C	Freeze Time			Harvest Time
	Water Temperature °F/°C			
	50/10	70/21	90/32	
-20 to 70/ -29 to 21	9.2-10.1	10.2-11.2	11.4-12.4	<b>.75-2.5</b>
<b>90/32</b>	10.1-11.0	10.6-11.5	12.4-13.5	
<b>100/38</b>	10.6-11.6	11.6-12.7	12.9-14.1	
<b>110/43</b>	11.1-12.1	12.2-13.3	13.5-14.7	

<sup>1</sup>Times in minutes.

### 24-HOUR ICE PRODUCTION

Air Temp. Entering Condenser °F/°C	Water Temperature °F/°C		
	50/10	70/21	90/32
-20 to 70/ -29 to 21	2080	1905	1735
<b>90/32</b>	1925	1850	1610
<b>100/38</b>	1845	1700	1545
<b>110/43</b>	1770	1625	1485

<sup>1</sup> Based on average ice weight of one Harvest cycle 15.5-16.75 lb. (7.75-8.38 lb. per evaporator).

### OPERATING PRESSURES

Air Temp. Entering Condenser °F/°C	Freeze Cycle		Harvest Cycle	
	Discharge Pressure psig	Suction Pressure psig	Discharge Pressure psig	Suction Pressure psig
-20 to 70/ -29 to 21	205-245	30-16	130-175	45-60
<b>80/27</b>	230-250	30-18	185-200	50-65
<b>90/32</b>	230-275	35-18	185-200	50-65
<b>100/38</b>	240-290	35-19	190-210	50-70
<b>110/43</b>	310-380	38-20	200-240	60-80
<b>120/49</b>	320-390	40-22	225-240	70-80

During low ambient conditions, it is normal for the head pressure control valve to hunt (fluctuate up and down) on CVD condensing units. Hunting varies by model and ambient temperature, but generally settles out within the first 6 minutes of the freeze cycle

## SY2074C/CVD2075 SERIES REMOTE AIR COOLED

NOTE: These characteristics may vary depending on operating conditions.

### CYCLE TIMES

Freeze Time + Harvest Time = Cycle Time				
Air Temp. Entering Condenser °F/°C	Freeze Time			Harvest Time
	Water Temperature °F/°C			
	50/10	70/21	90/32	
-20 to 70/ -29 to 21	8.8-9.6	9.7-10.6	10.8-11.8	<b>.75-2.5</b>
90/32	9.7-10.7	10.0-10.9	11.7-12.8	
100/38	10.3-11.3	11.2-12.2	12.2-13.3	
110/43	10.9-11.9	11.8-12.9	12.8-14.0	

<sup>1</sup>Times in minutes.

### 24-HOUR ICE PRODUCTION

Air Temp. Entering Condenser °F/°C	Water Temperature °F/°C		
	50/10	70/21	90/32
-20 to 70/ -29 to 21	2170	1995	1810
90/32	1985	1945	1690
100/38	1890	1760	1625
110/43	1800	1680	1560

<sup>1</sup> Based on average ice weight of one Harvest cycle 15.5-16.75 lb. (7.75-8.38 lb. per evaporator).

### OPERATING PRESSURES

Air Temp. Entering Condenser °F/°C	Freeze Cycle		Harvest Cycle	
	Discharge Pressure psig	Suction Pressure psig	Discharge Pressure psig	Suction Pressure psig
-20 to 70/ -29 to 21	205-245	30-16	130-175	45-60
80/27	230-250	30-18	185-200	50-65
90/32	230-275	35-18	185-200	50-65
100/38	240-290	35-19	190-210	50-70
110/43	310-380	38-20	200-240	60-80
120/49	320-390	40-22	225-240	70-80

During low ambient conditions, it is normal for the head pressure control valve to hunt (fluctuate up and down) on CVD condensing units. Hunting varies by model and ambient temperature, but generally settles out within the first 6 minutes of the freeze cycle

## SD2172C/CVD2085 SERIES REMOTE AIR COOLED

NOTE: These characteristics may vary depending on operating conditions.

### CYCLE TIMES

Freeze Time + Harvest Time = Cycle Time				
Air Temp. Entering Condenser °F/°C	Freeze Time			Harvest Time
	Water Temperature °F/°C			
	50/10	70/21	90/32	
-20 to 70/ -29 to 21	10.2-11.2	11.2-12.2	12.3-13.4	<b>.75-2.5</b>
90/32	11.6-12.6	11.8-12.9	13.8-15.0	
100/38	12.4-13.5	13.4-14.6	14.6-15.9	
110/43	13.3-14.5	14.4-15.7	15.6-17.0	

<sup>1</sup>Times in minutes.

### 24-HOUR ICE PRODUCTION

Air Temp. Entering Condenser °F/°C	Water Temperature °F/°C		
	50/10	70/21	90/32
-20 to 70/ -29 to 21	1905	1706	1615
90/32	1705	1675	1460
100/38	1605	1495	1385
110/43	1505	1405	1305

<sup>1</sup> Based on average ice weight of one Harvest cycle 15.5-16.75 lb. (7.75-8.38 lb. per evaporator).

### OPERATING PRESSURES

Air Temp. Entering Condenser °F/°C	Freeze Cycle		Harvest Cycle	
	Discharge Pressure psig	Suction Pressure psig	Discharge Pressure psig	Suction Pressure psig
-20 to 70/ -29 to 21	230-250	40-20	150-170	60-80
80/27	255-230	40-21	155-170	60-80
90/32	260-235	40-21	160-180	65-80
100/38	325-260	40-21	165-185	75-85
110/43	380-320	46-23	180-205	90-100
120/49	390-330	48-24	190-210	95-110

During low ambient conditions, it is normal for the head pressure control valve to hunt (fluctuate up and down) on CVD condensing units. Hunting varies by model and ambient temperature, but generally settles out within the first 6 minutes of the freeze cycle

## SY2174C/CVD2085 SERIES REMOTE AIR COOLED

NOTE: These characteristics may vary depending on operating conditions.

### CYCLE TIMES

Freeze Time + Harvest Time = Cycle Time				
Air Temp. Entering Condenser °F/°C	Freeze Time			Harvest Time
	Water Temperature °F/°C			
	50/10	70/21	90/32	
-20 to 70/ -29 to 21	9.7-10.6	10.6-11.5	11.5-12.6	<b>.75-2.5</b>
90/32	11.0-12.1	11.2-12.2	13.0-14.2	
100/38	11.8-12.9	12.8-14.0	14.0-15.3	
110/43	12.8-13.9	13.8-15.0	15.0-16.4	

<sup>1</sup>Times in minutes.

### 24-HOUR ICE PRODUCTION

Air Temp. Entering Condenser °F/°C	Water Temperature °F/°C		
	50/10	70/21	90/32
-20 to 70/ -29 to 21	1990	1850	1715
90/32	1780	1755	1535
100/38	1675	1560	1440
110/43	1565	1460	1350

<sup>1</sup> Based on average ice weight of one Harvest cycle 15.5-16.75 lb. (7.75-8.38 lb. per evaporator).

### OPERATING PRESSURES

Air Temp. Entering Condenser °F/°C	Freeze Cycle		Harvest Cycle	
	Discharge Pressure psig	Suction Pressure psig	Discharge Pressure psig	Suction Pressure psig
-20 to 70/ -29 to 21	230-250	40-20	150-170	60-80
80/27	255-230	40-21	155-170	60-80
90/32	260-235	40-21	160-180	65-80
100/38	325-260	40-21	165-185	75-85
110/43	380-320	46-23	180-205	90-100
120/49	390-330	48-24	190-210	95-110

During low ambient conditions, it is normal for the head pressure control valve to hunt (fluctuate up and down) on CVD condensing units. Hunting varies by model and ambient temperature, but generally settles out within the first 6 minutes of the freeze cycle

## SDF3000C/CVDF3000 SERIES REMOTE AIR COOLED

NOTE: These characteristics may vary depending on operating conditions.

### CYCLE TIMES

Freeze Time + Harvest Time = Cycle Time				
Air Temp. Entering Condenser °F/°C	Freeze Time			Harvest Time
	Water Temperature °F/°C			
	50/10	70/21	90/32	
-20 to 70/ -29 to 21	10.9-12.4	11.8-13.4	12.6-14.3	0.75-2.5
90/32	12.3-14.0	13.4-15.4	14.5-16.5	
100/38	13.2-15.0	14.5-16.5	15.7-17.8	
110/43	14.5-16.5	16.1-18.3	17.6-19.9	

<sup>1</sup>Times in minutes.

### 24-HOUR ICE PRODUCTION

Air Temp. Entering Condenser °F/°C	Water Temperature °F/°C		
	50/10	70/21	90/32
-20 to 70/ -29 to 21	2850	2650	2500
90/32	2550	2350	2200
100/38	2400	2200	2050
110/43	2200	2000	1850

<sup>1</sup> Based on average ice weight of one Harvest cycle 24.5-27.5 lb. (6.38-7.13 lb. per evaporator).

### OPERATING PRESSURES

Air Temp. Entering Condenser °F/°C	Freeze Cycle		Harvest Cycle	
	Discharge Pressure psig	Suction Pressure psig	Discharge Pressure psig	Suction Pressure psig
-20 to 70/ -29 to 21	250-220	48-30	135-150	70-85
80/27	300-240	50-30	145-170	70-90
90/32	320-280	55-32	165-190	80-100
100/38	350-310	60-33	180-200	90-110
110/43	400-350	65-35	180-210	100-115

During low ambient conditions, it is normal for the head pressure control valve to hunt (fluctuate up and down) on CVD condensing units. Hunting varies by model and ambient temperature, but generally settles out within the first 6 minutes of the freeze cycle. Verify the direction of rotation correct is correct on the 3ph scroll compressor. The ice machine will have high suction pressure, low discharge pressure and will be noticeably loud. Reverse any two incoming power leads to reverse rotation

## SYF3000C/CVDF3000 SERIES REMOTE AIR COOLED

NOTE: These characteristics may vary depending on operating conditions.

### CYCLE TIMES

Freeze Time + Harvest Time = Cycle Time				
Air Temp. Entering Condenser °F/°C	Freeze Time			Harvest Time
	Water Temperature °F/°C			
	50/10	70/21	90/32	
-20 to 70/ -29 to 21	10.6-12.1	11.2-12.8	12.6-14.3	0.75-2.5
90/32	11.8-13.4	13.1-14.9	14.8-16.8	
100/38	12.5-14.2	14.0-15.9	16.0-18.1	
110/43	13.4-15.3	15.1-17.2	17.5-19.8	

<sup>1</sup>Times in minutes.

### 24-HOUR ICE PRODUCTION

Air Temp. Entering Condenser °F/°C	Water Temperature °F/°C		
	50/10	70/21	90/32
-20 to 70/ -29 to 21	2910	2770	2510
90/32	2660	2420	2160
100/38	2520	2280	2020
110/43	2360	2120	1860

<sup>1</sup> Based on average ice weight of one Harvest cycle 24.5-27.5 lb. (6.38-7.13 lb. per evaporator).

### OPERATING PRESSURES

Air Temp. Entering Condenser °F/°C	Freeze Cycle		Harvest Cycle	
	Discharge Pressure psig	Suction Pressure psig	Discharge Pressure psig	Suction Pressure psig
-20 to 70/ -29 to 21	250-220	48-30	135-150	70-85
80/27	300-240	50-30	145-170	70-90
90/32	320-280	55-32	165-190	80-100
100/38	350-310	60-33	180-200	90-110
110/43	400-350	65-35	180-210	100-115

During low ambient conditions, it is normal for the head pressure control valve to hunt (fluctuate up and down) on CVD condensing units. Hunting varies by model and ambient temperature, but generally settles out within the first 6 minutes of the freeze cycle. Verify the direction of rotation correct is correct on the 3ph scroll compressor. The ice machine will have high suction pressure, low discharge pressure and will be noticeably loud. Reverse any two incoming power leads to reverse rotation

## SD3072C/CVD3085 SERIES REMOTE AIR COOLED

NOTE: These characteristics may vary depending on operating conditions.

### CYCLE TIMES

Freeze Time + Harvest Time = Cycle Time				
Air Temp. Entering Condenser °F/°C	Freeze Time			Harvest Time
	Water Temperature °F/°C			
	50/10	70/21	90/32	
-20 to 70/ -29 to 21	10.9-12.4	11.8-13.4	12.6-14.3	0.75-2.5
90/32	12.3-14.0	13.4-15.4	14.5-16.5	
100/38	13.2-15.0	14.5-16.5	15.7-17.8	
110/43	14.5-16.5	16.1-18.3	17.6-19.9	

<sup>1</sup>Times in minutes.

### 24-HOUR ICE PRODUCTION

Air Temp. Entering Condenser °F/°C	Water Temperature °F/°C		
	50/10	70/21	90/32
-20 to 70/ -29 to 21	2850	2650	2500
90/32	2550	2350	2200
100/38	2400	2200	2050
110/43	2200	2000	1850

<sup>1</sup> Based on average ice weight of one Harvest cycle 24.5-27.5 lb. (6.38-7.13 lb. per evaporator).

### OPERATING PRESSURES

Air Temp. Entering Condenser °F/°C	Freeze Cycle		Harvest Cycle	
	Discharge Pressure psig	Suction Pressure psig	Discharge Pressure psig	Suction Pressure psig
-20 to 70/ -29 to 21	250-220	48-30	135-150	70-85
80/27	300-240	50-30	145-170	70-90
90/32	320-280	55-32	165-190	80-100
100/38	350-310	60-33	180-200	90-110
110/43	400-350	65-35	180-210	100-115

During low ambient conditions, it is normal for the head pressure control valve to hunt (fluctuate up and down) on CVD condensing units. Hunting varies by model and ambient temperature, but generally settles out within the first 6 minutes of the freeze cycle

NOTE: CVD3085 Models - Verify the direction of rotation correct is correct on the 3ph scroll compressor. The ice machine will have high suction pressure, low discharge pressure and will be noticeably loud. Reverse any two incoming power leads to reverse rotation.

## SY3074C/CVD3085 SERIES REMOTE AIR COOLED

NOTE: These characteristics may vary depending on operating conditions.

### CYCLE TIMES

Freeze Time + Harvest Time = Cycle Time				
Air Temp. Entering Condenser °F/°C	Freeze Time			Harvest Time
	Water Temperature °F/°C			
	50/10	70/21	90/32	
-20 to 70/ -29 to 21	10.6-12.1	11.2-12.8	12.6-14.3	0.75-2.5
90/32	11.8-13.4	13.1-14.9	14.8-16.8	
100/38	12.5-14.2	14.0-15.9	16.0-18.1	
110/43	13.4-15.3	15.1-17.2	17.5-19.8	

<sup>1</sup>Times in minutes.

### 24-HOUR ICE PRODUCTION

Air Temp. Entering Condenser °F/°C	Water Temperature °F/°C		
	50/10	70/21	90/32
-20 to 70/ -29 to 21	2910	2770	2510
90/32	2660	2420	2160
100/38	2520	2280	2020
110/43	2360	2120	1860

<sup>1</sup> Based on average ice weight of one Harvest cycle 24.5-27.5 lb. (6.38-7.13 lb. per evaporator).

### OPERATING PRESSURES

Air Temp. Entering Condenser °F/°C	Freeze Cycle		Harvest Cycle	
	Discharge Pressure psig	Suction Pressure psig	Discharge Pressure psig	Suction Pressure psig
-20 to 70/ -29 to 21	250-220	48-30	135-150	70-85
80/27	300-240	50-30	145-170	70-90
90/32	320-280	55-32	165-190	80-100
100/38	350-310	60-33	180-200	90-110
110/43	400-350	65-35	180-210	100-115

During low ambient conditions, it is normal for the head pressure control valve to hunt (fluctuate up and down) on CVD condensing units. Hunting varies by model and ambient temperature, but generally settles out within the first 6 minutes of the freeze cycle

NOTE: CVD3085 Models - Verify the direction of rotation correct is correct on the 3ph scroll compressor. The ice machine will have high suction pressure, low discharge pressure and will be noticeably loud. Reverse any two incoming power leads to reverse rotation.

# Diagrams

## Wiring Diagrams

The following pages contain electrical wiring diagrams. Be sure you are referring to the correct diagram for the ice machine you are servicing.



### Warning

Always disconnect power before working on electrical circuitry.

### WIRING DIAGRAM LEGEND

The following symbols are used on all of the wiring diagrams:

- \* Internal Compressor Overload  
(Some models have external compressor overloads)
- \*\* Fan Motor Run Capacitor  
(Some models do not incorporate fan motor run capacitor)
- ( ) Wire Number Designation  
(The number is marked at each end of the wire)
- >>— Multi-Pin Connection  
(Electrical Box Side) —>>—  
(Compressor Compartment Side)

# S600C/S850C/1000C/S1200C Ice Machine Head Section

See Serial Plate for Voltage

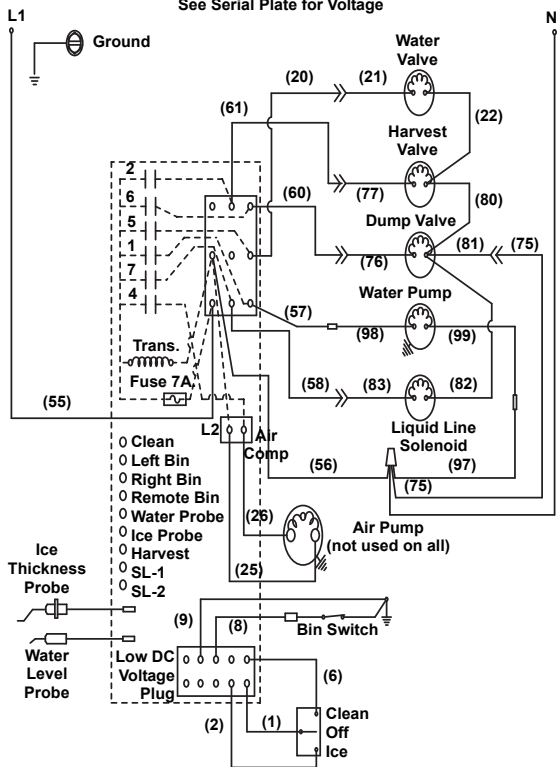

# S600C/S680C/S850C/1000C/S1200C

## Ice Machine Head Section

### Air Pump wired with the Harvest Valve

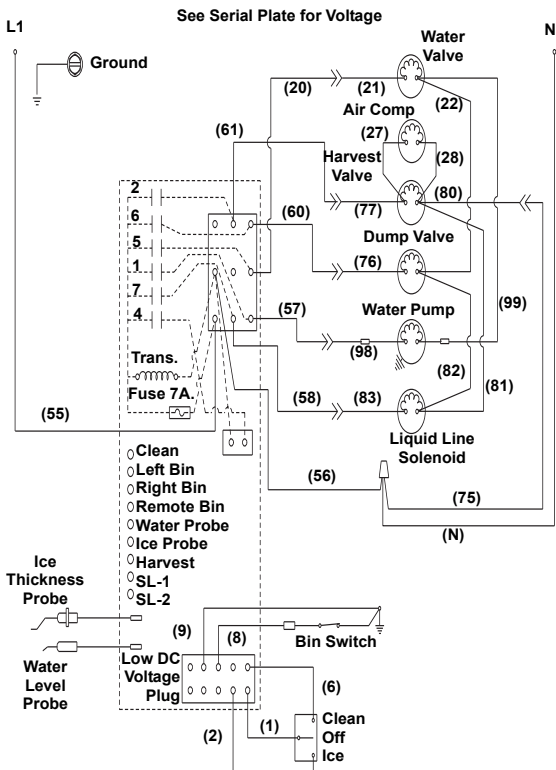

# S1470C/S1870C/S2070C/S2170C

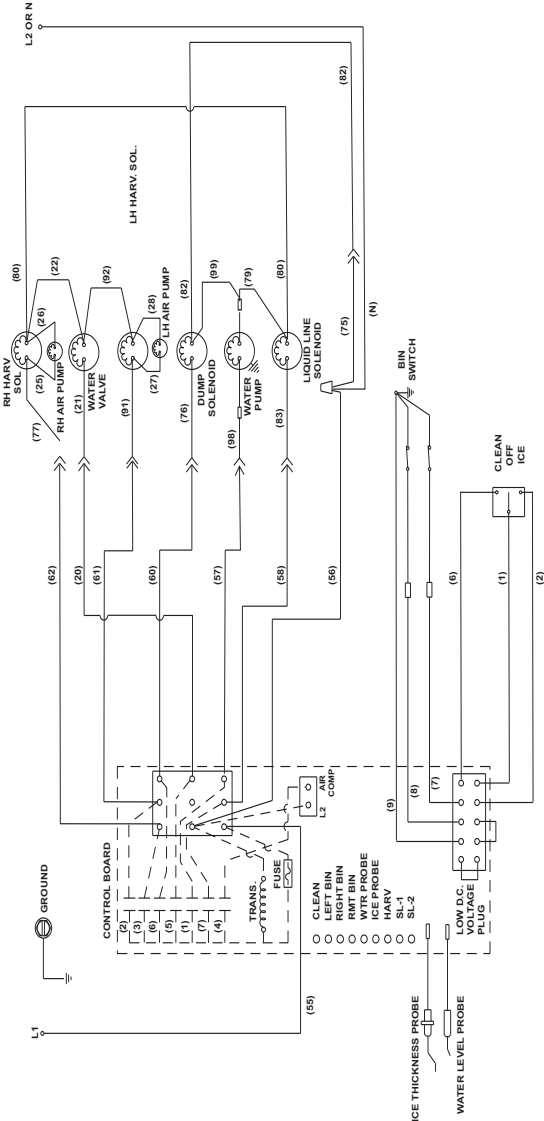

# SF3000C/S3070C 115/60/1

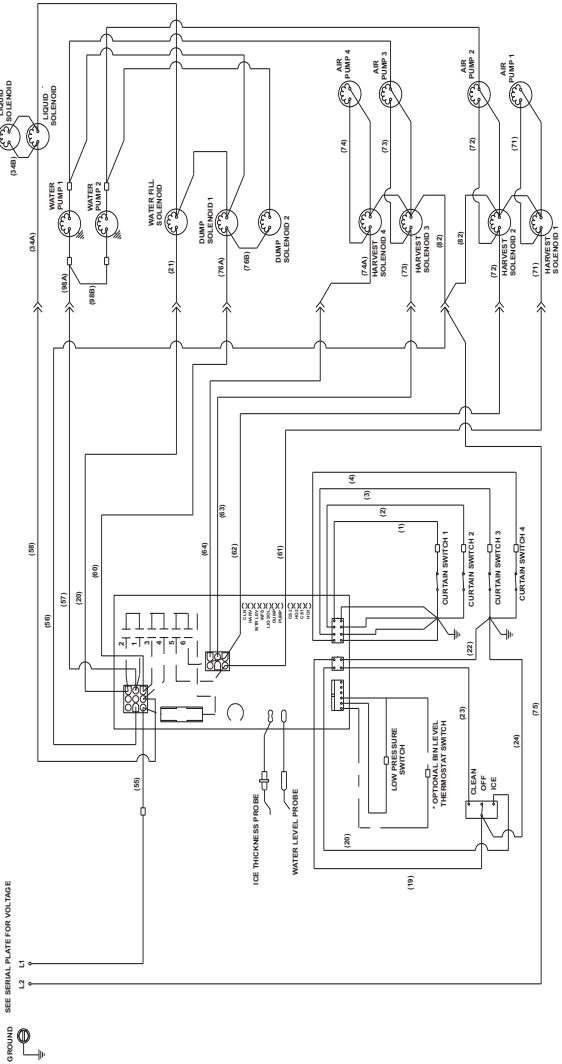



# IB0600C/IB0800C/IB1000C WITH S CONTROL BOARD AND ELECTRONIC BIN THERMOSTAT

## Ice Machine Head Section

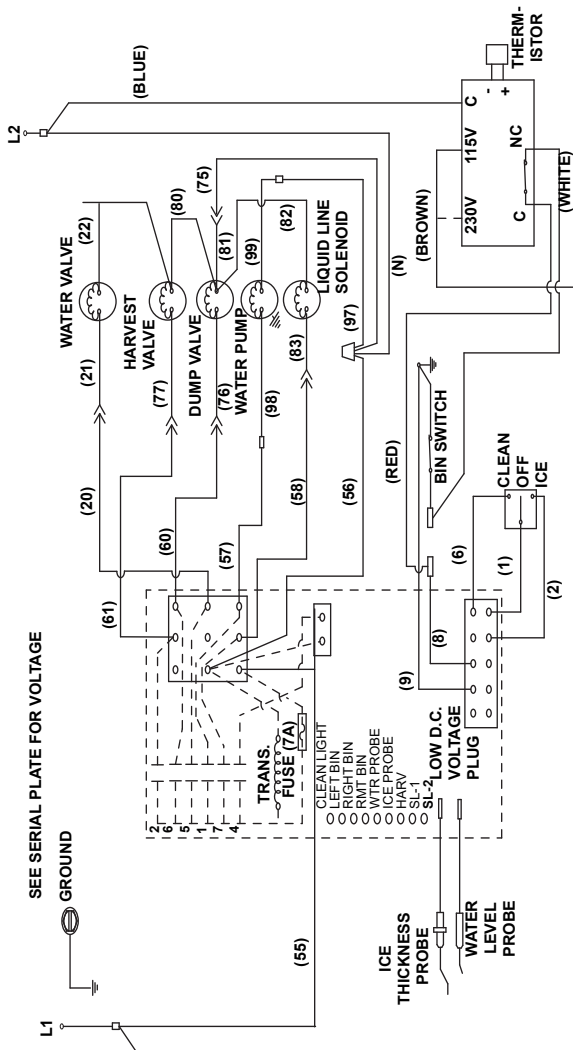

# IB0600C/IB0680C/IB0800C/IB1000C WITH AIR ASSIST/ S CONTROL BOARD AND ELECTRONIC BIN THERMOSTAT

## Ice Machine Head Section

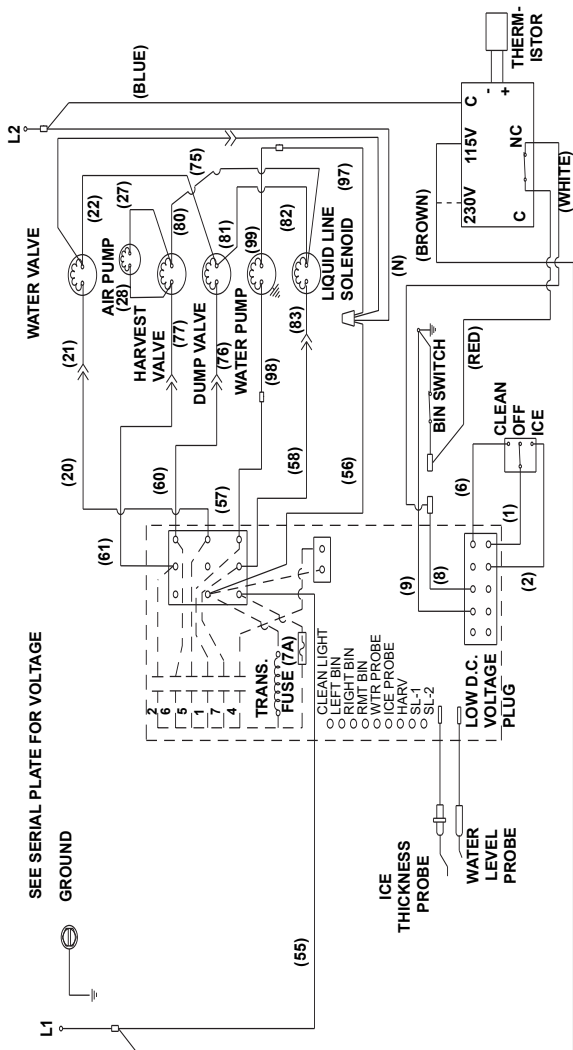

**CVD675/CVD685/CVD885/CVD1075/CVD1085/  
CVD1185/CVD1285/CVD1485/CVD1486/CVD1885/  
CVD2075/CVD3085/CVDF3000 - 1 PHASE**

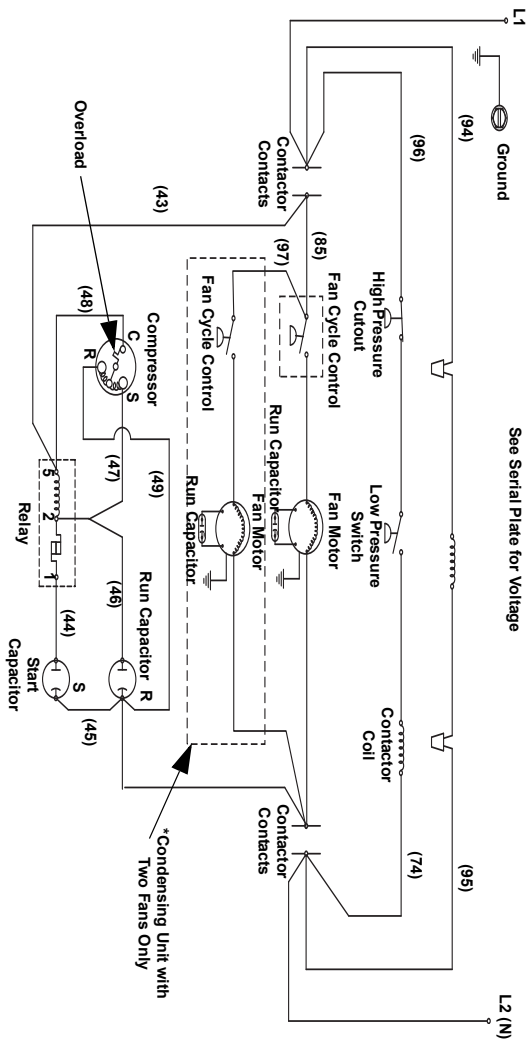

# CVD2085 WITHOUT PTCR- 1 PHASE

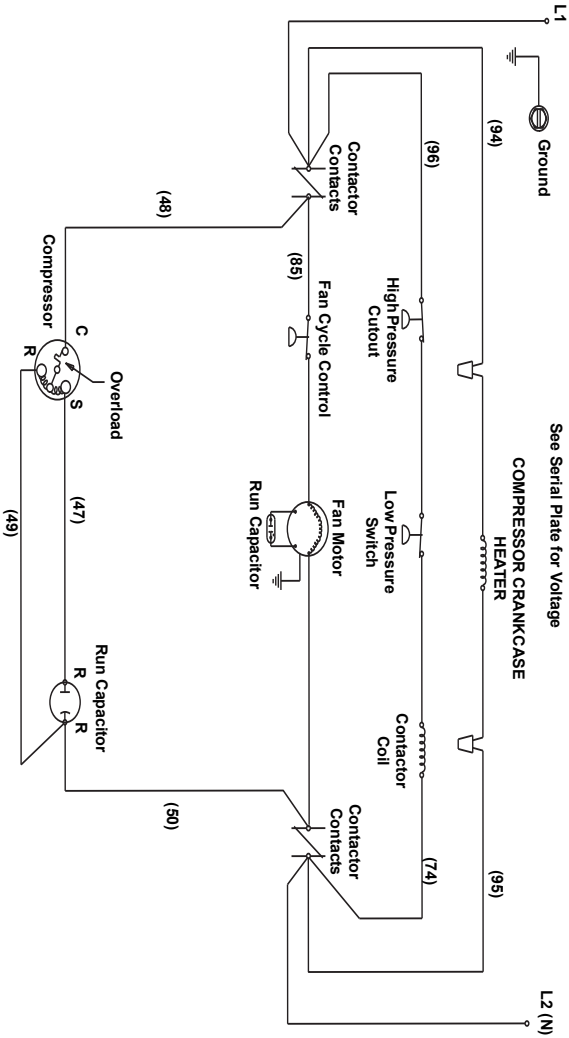

# CVD2085 WITH PTCR- 1 PHASE

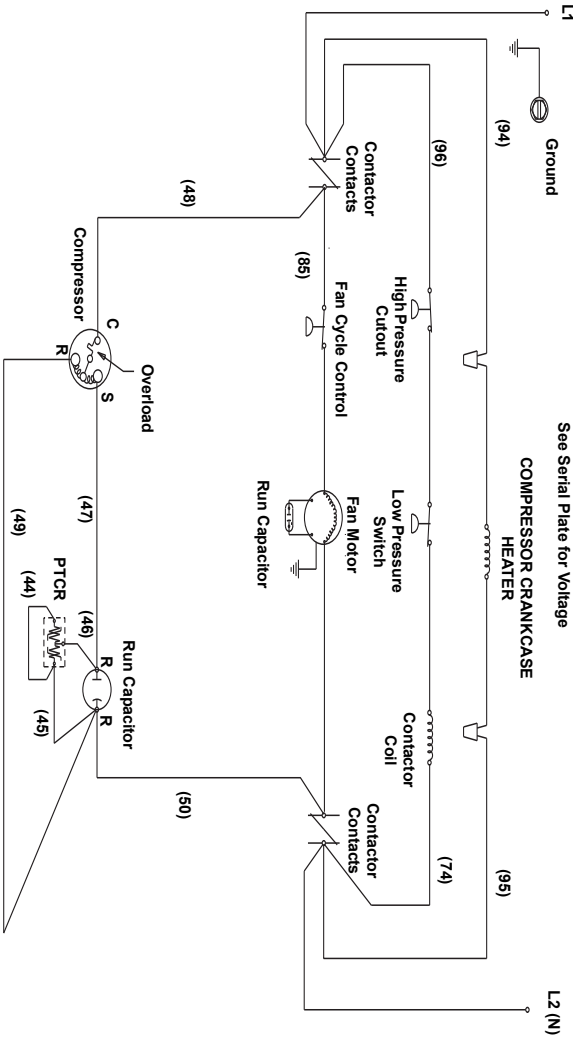

**CVD675/CVD685/CVD885/CVD1075/CVD1085/  
 CVD1185/CVD1285/CVD1485/CVD1486/CVD1885/  
 CVD2075/CVD2085/CVD3085/CVDF3000 - 3 PHASE**

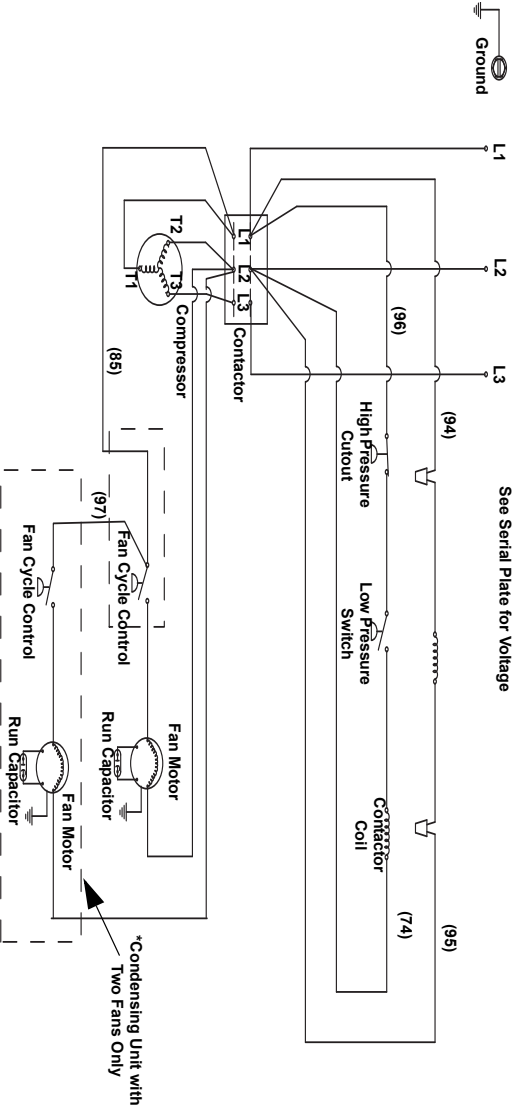

CVD3085/CVDF3000 380V/50HZ/3PH

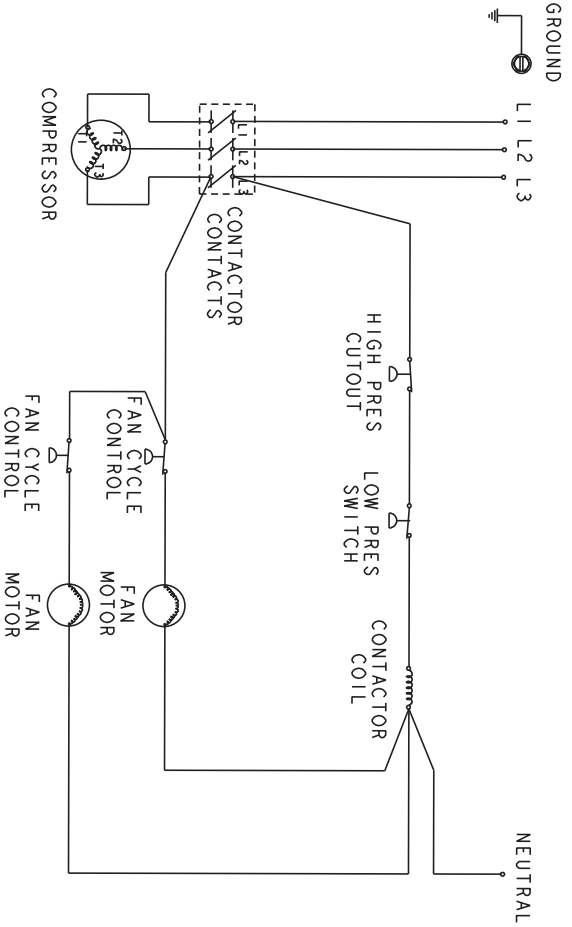

# Electronic Control Board

## SINGLE AND TWIN EVAPORATOR MODELS

### Without Test Button

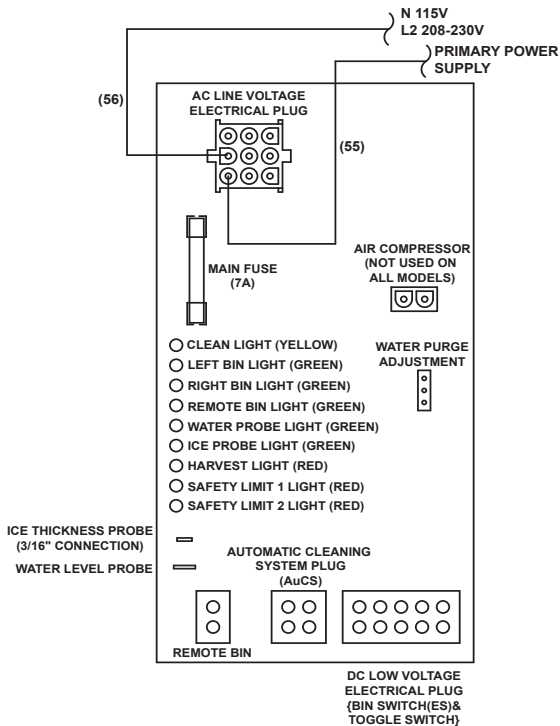

# Single and Twin Evaporator With Test Button

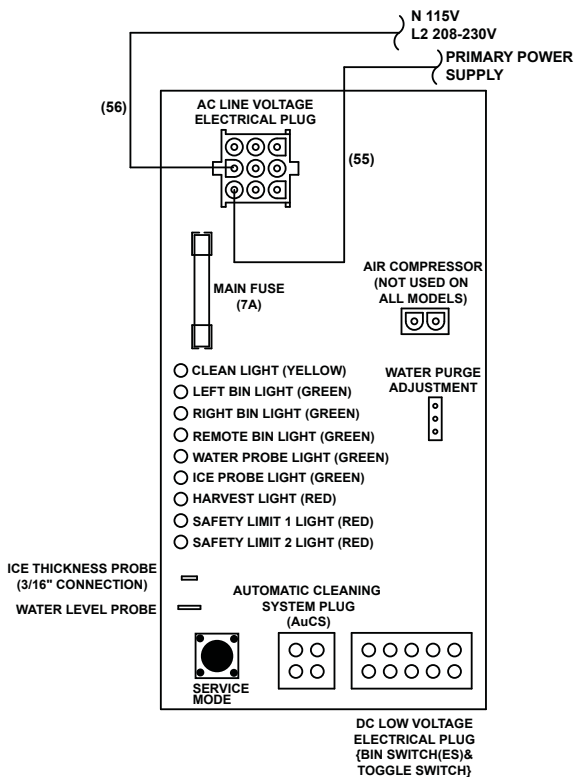

# QUAD EVAPORATOR MODELS

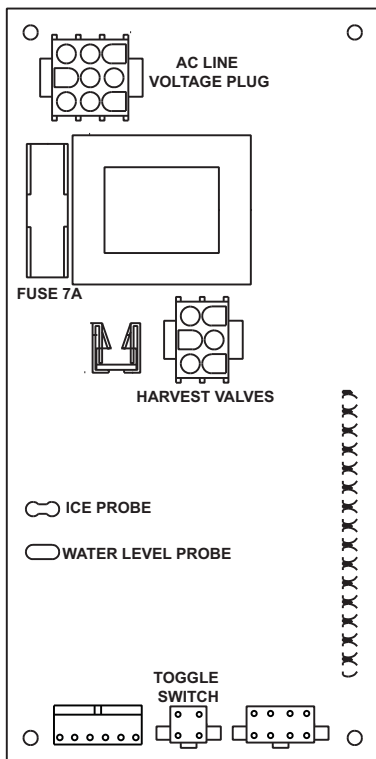

- CLEAN (YELLOW)
- HARVEST (RED)
- WATER LEVEL (GREEN)
- WATER SOLENOID (RED)
- LIQUID SOLENOID (RED)
- DUMP VALVE (RED)
- WATER PUMP (RED)
- CURTAIN SWITCH 4 (GREEN)
- HARVEST VALVE 4 (RED)
- CURTAIN SWITCH 3 (GREEN)
- HARVEST VALVE 3 (RED)
- CURTAIN SWITCH 2 (GREEN)
- HARVEST VALVE 2 (RED)
- CURTAIN SWITCH 1 (GREEN)
- HARVEST VALVE 1 (RED)

LOW PRESSURE SWITCH      CURTAIN SWITCHES  
&  
OPTIONAL BIN THERMOSTAT

# Refrigeration Tubing Schematics

S600C/S680C/S850C/S1000C/S1200C

Without Check Valve

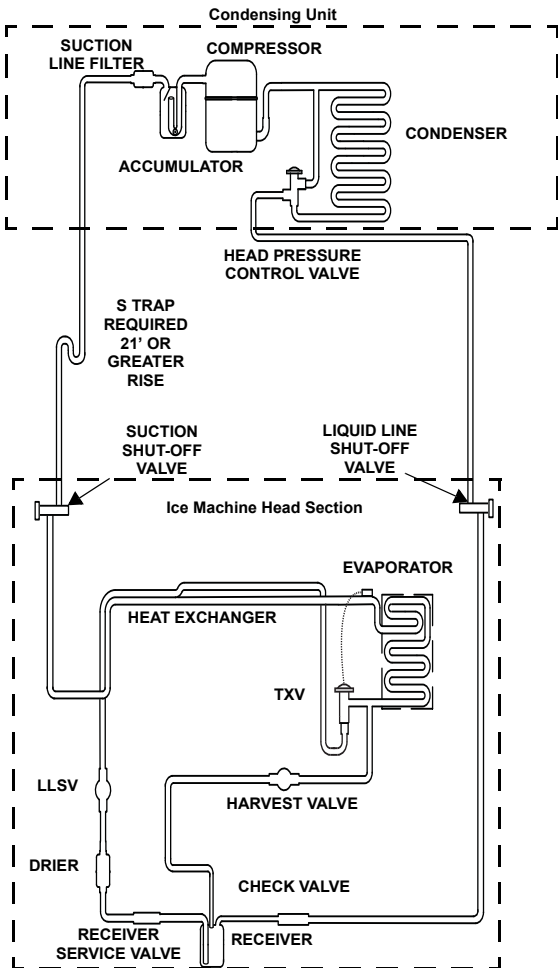

# S600C/S680C/S850C/S1000C/S1200C

## With Check Valve

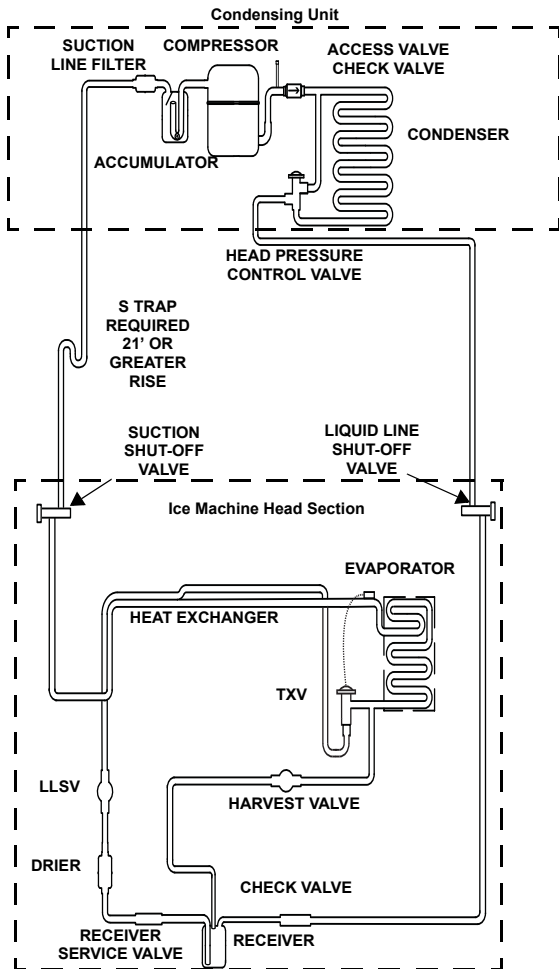

# ICE BEVERAGE IB0600C/IB0680C/IB0800C/ IB1000C

## Without Check Valve

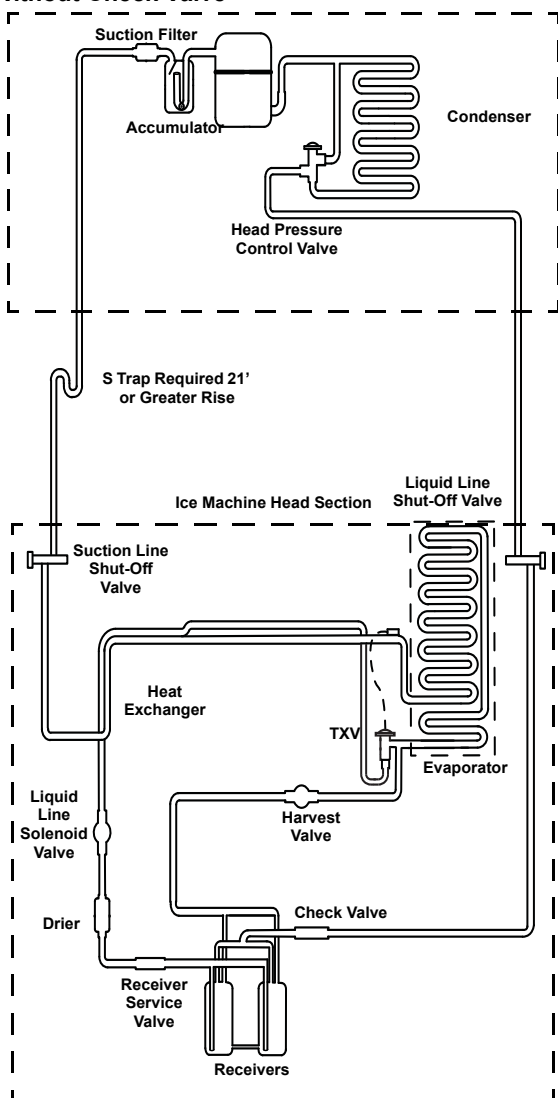

# ICE BEVERAGE IB0600C/IB0680C/IB0800C/ IB1000C

## With Check Valve

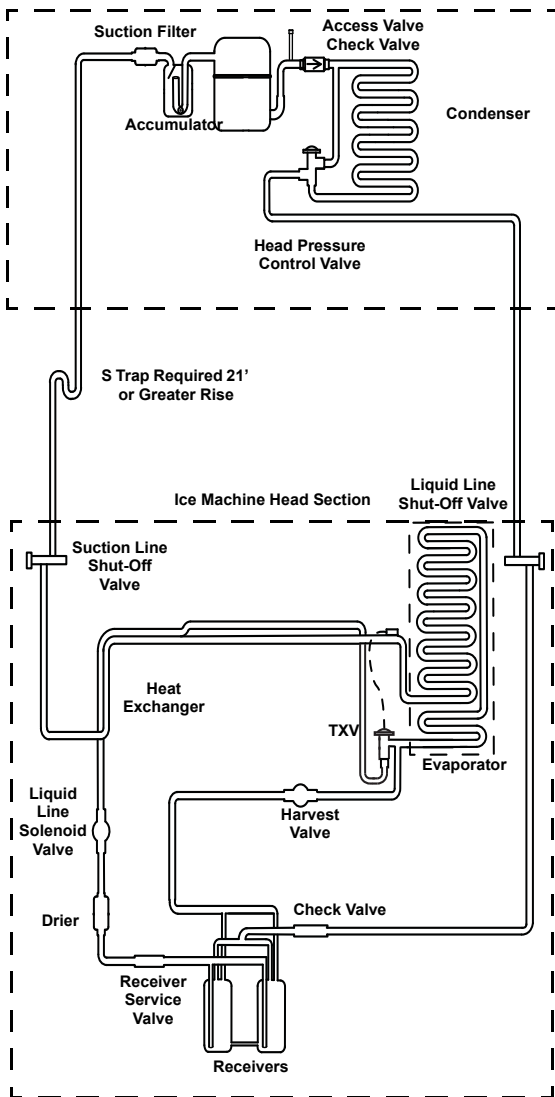

# S1470C/S1870C/S2070C/S2170C

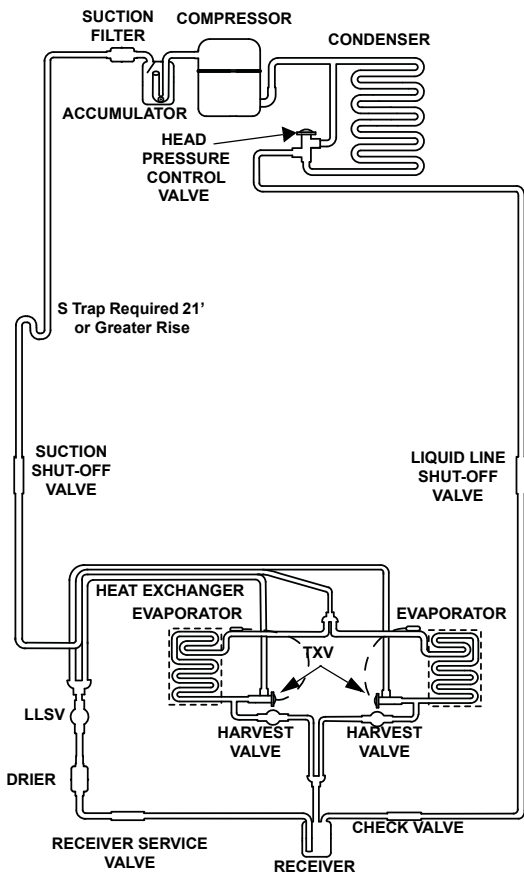

# S1470C/S1870C/S2070C/S2170C

## Without Check Valve

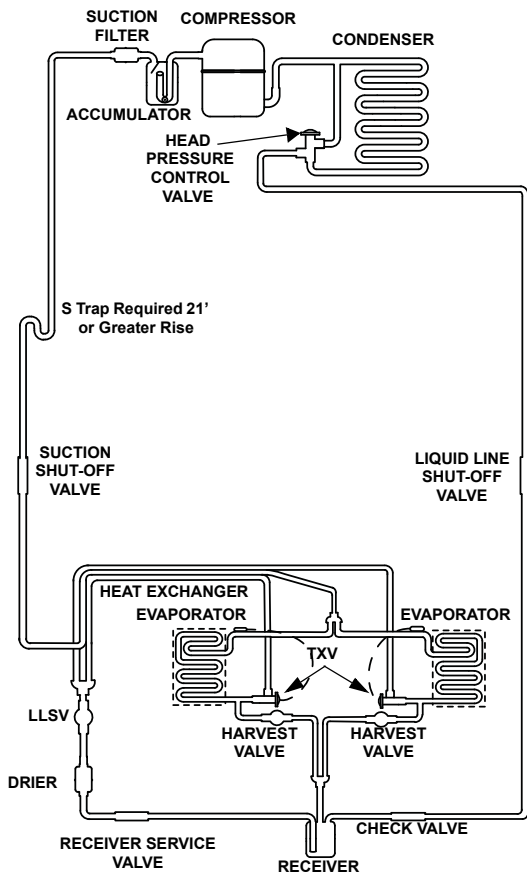

# S1476C Water-Cooled Condenser

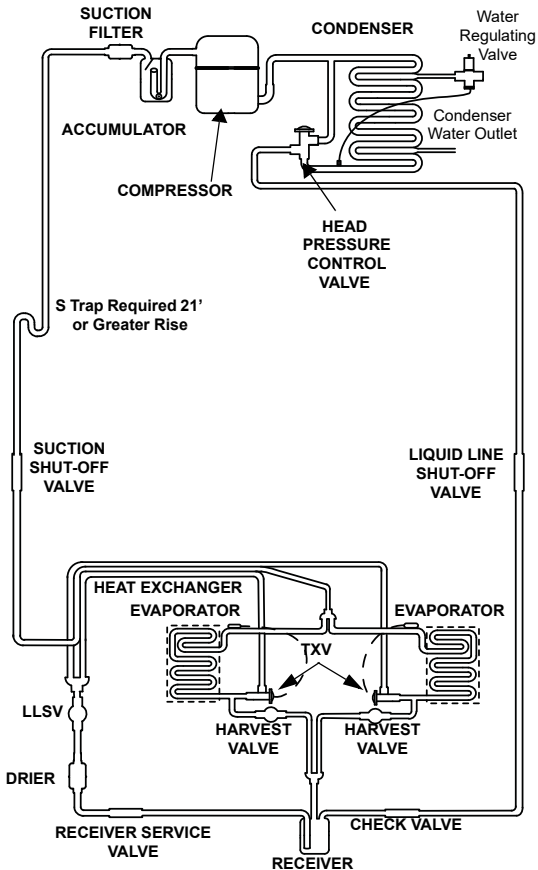

# S3070C Without Check Valve

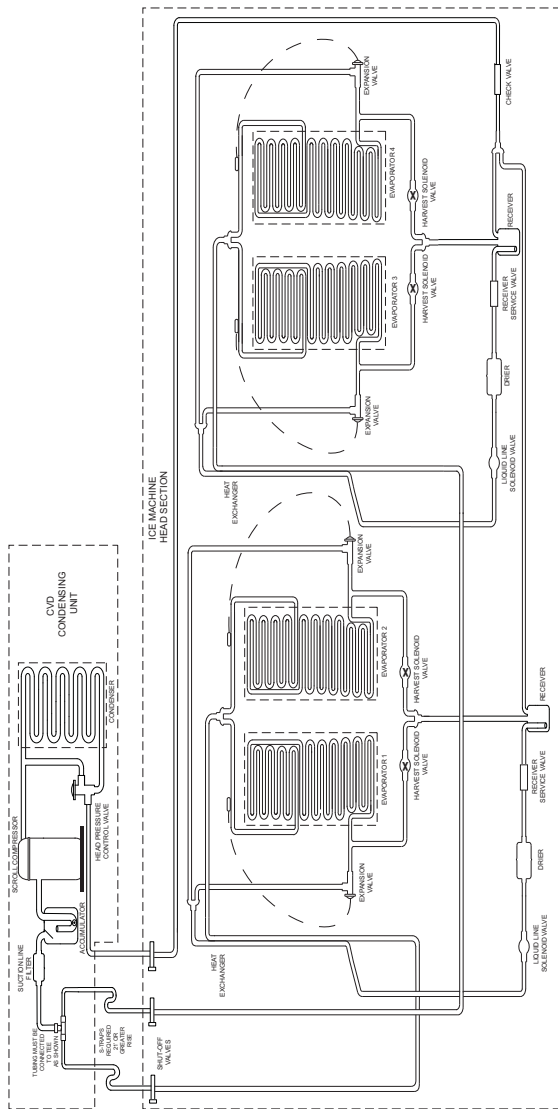

# SF3000C/S3070C WITH CHECK VALVE

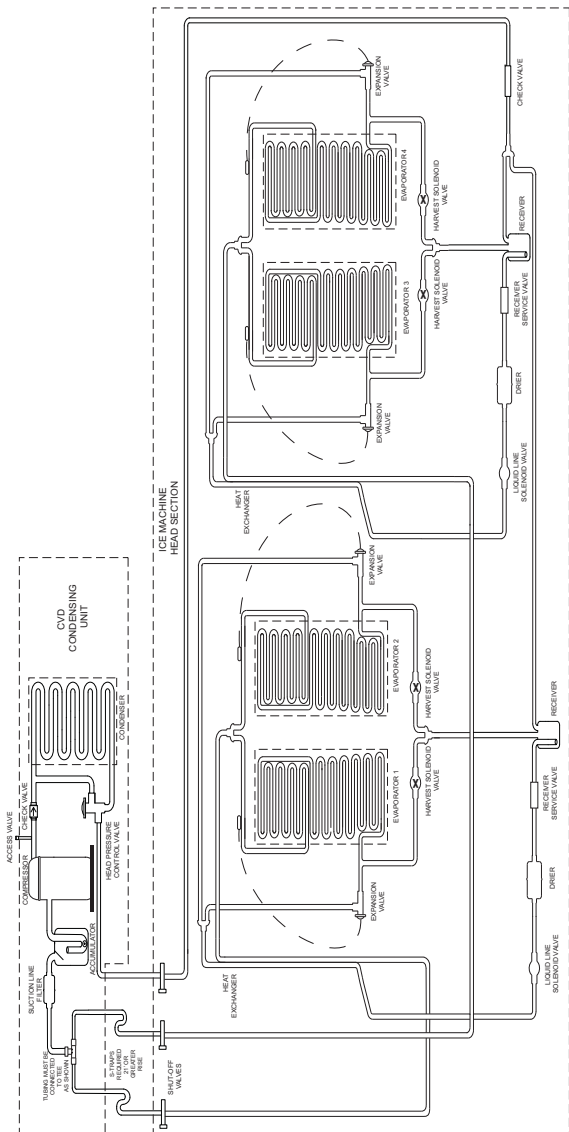

**This Page Intentionally Left Blank**

**This Page Intentionally Left Blank**

**This Page Intentionally Left Blank**









MANITOWOC ICE  
2110 SOUTH 26TH STREET  
MANITOWOC, WI 54220

---

800-545-5720  
[WWW.MANITOWOCICE.COM](http://WWW.MANITOWOCICE.COM)

©2018 Manitowoc Ice except where explicitly stated. All rights reserved.

Continuing product improvement may necessitate change of specifications without notice.

Part Number 8015053 6/18