

NOTE: DIAGRAM SHOWN DURING THE FREEZE CYCLE.  
SEE SERIAL PLATE FOR VOLTAGE

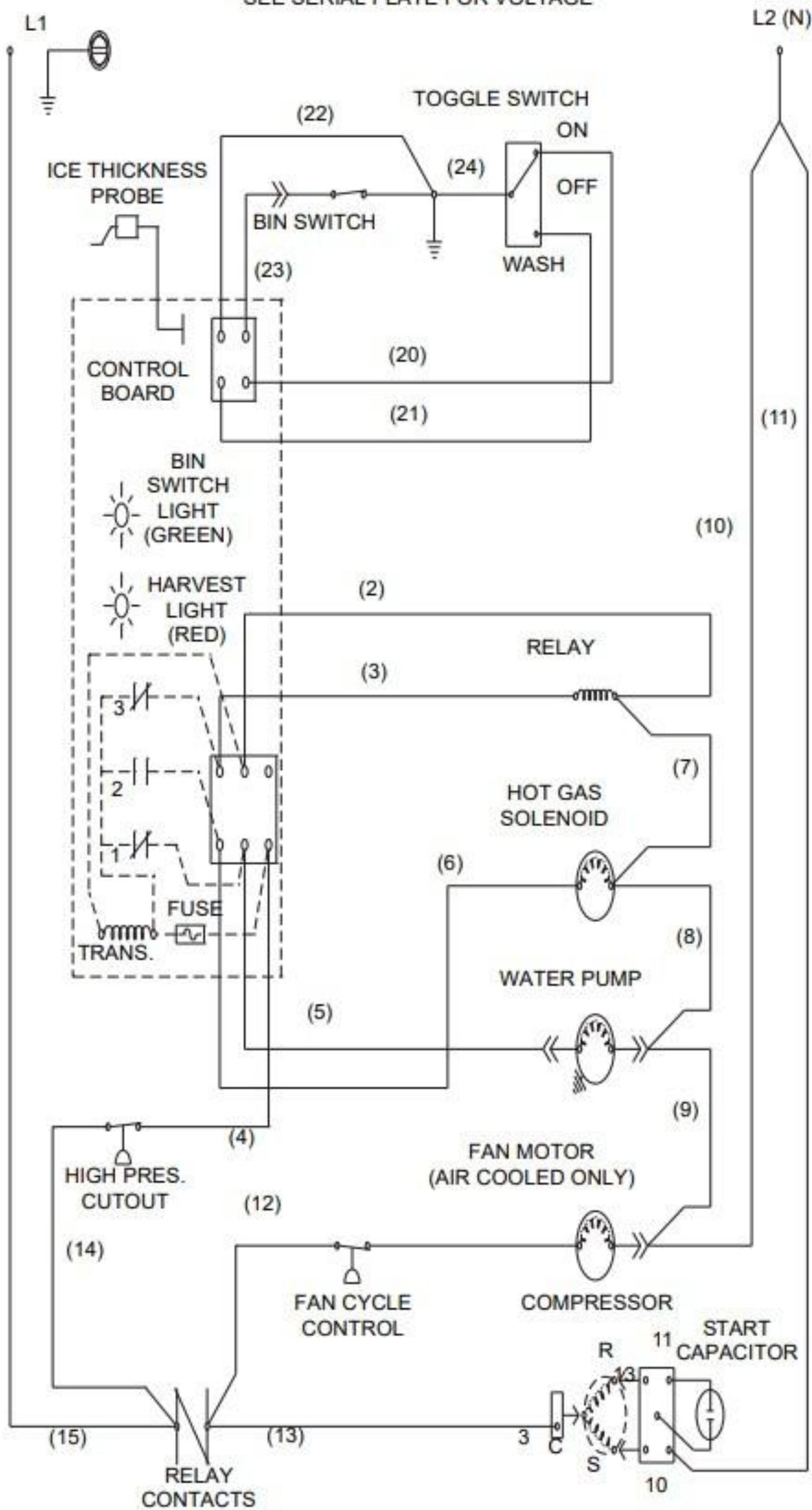

# Tecumseh Compressor

CAUTION: DISCONNECT POWER BEFORE WORKING ON ELECTRICAL CIRCUITRY.  
 DIAGRAM SHOWN DURING THE FREEZE CYCLE.  
 SEE SERIAL PLATE FOR VOLTAGE

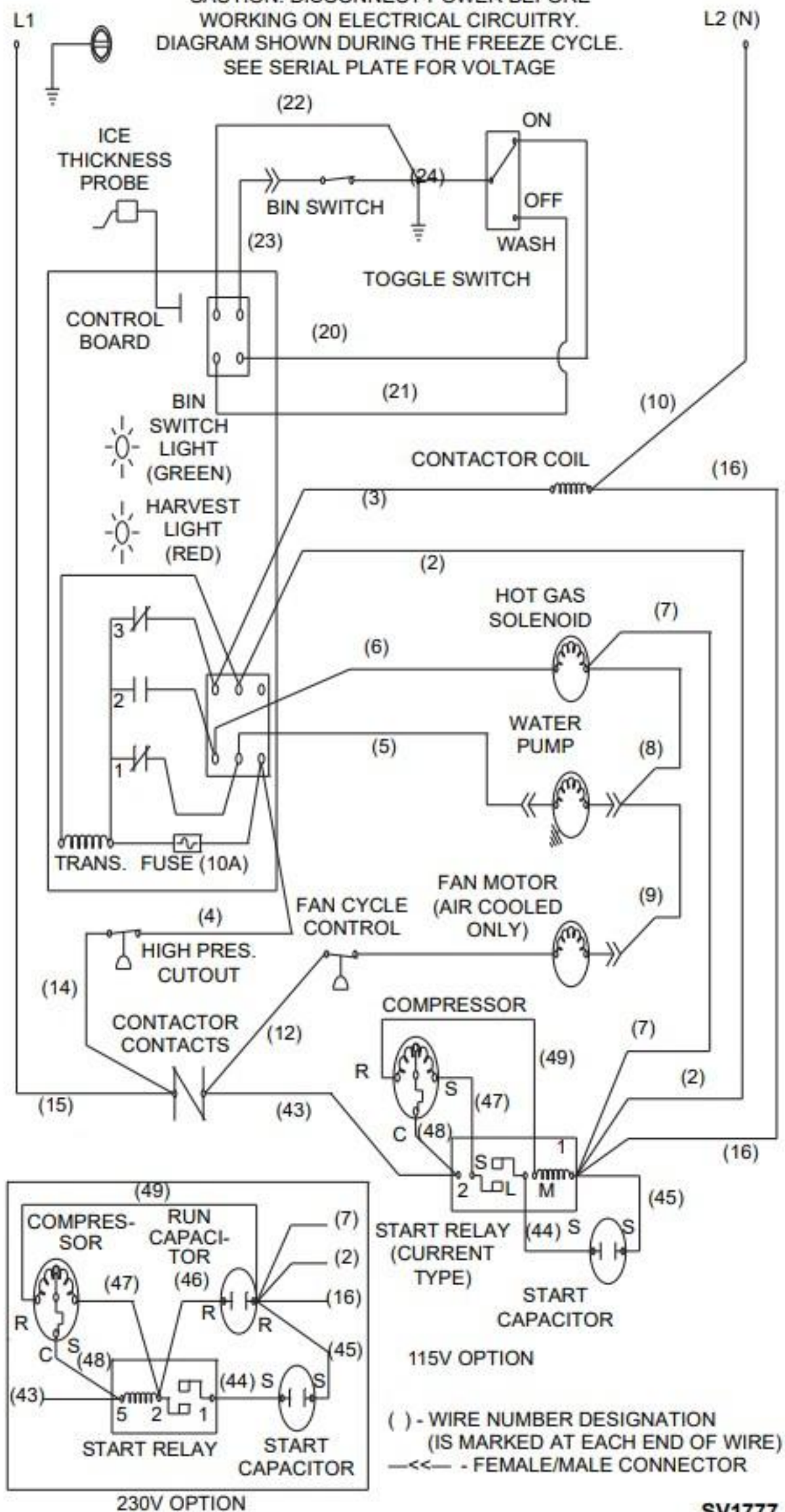

NOTE: DIAGRAM SHOWN DURING THE FREEZE CYCLE.  
SEE SERIAL PLATE FOR VOLTAGE

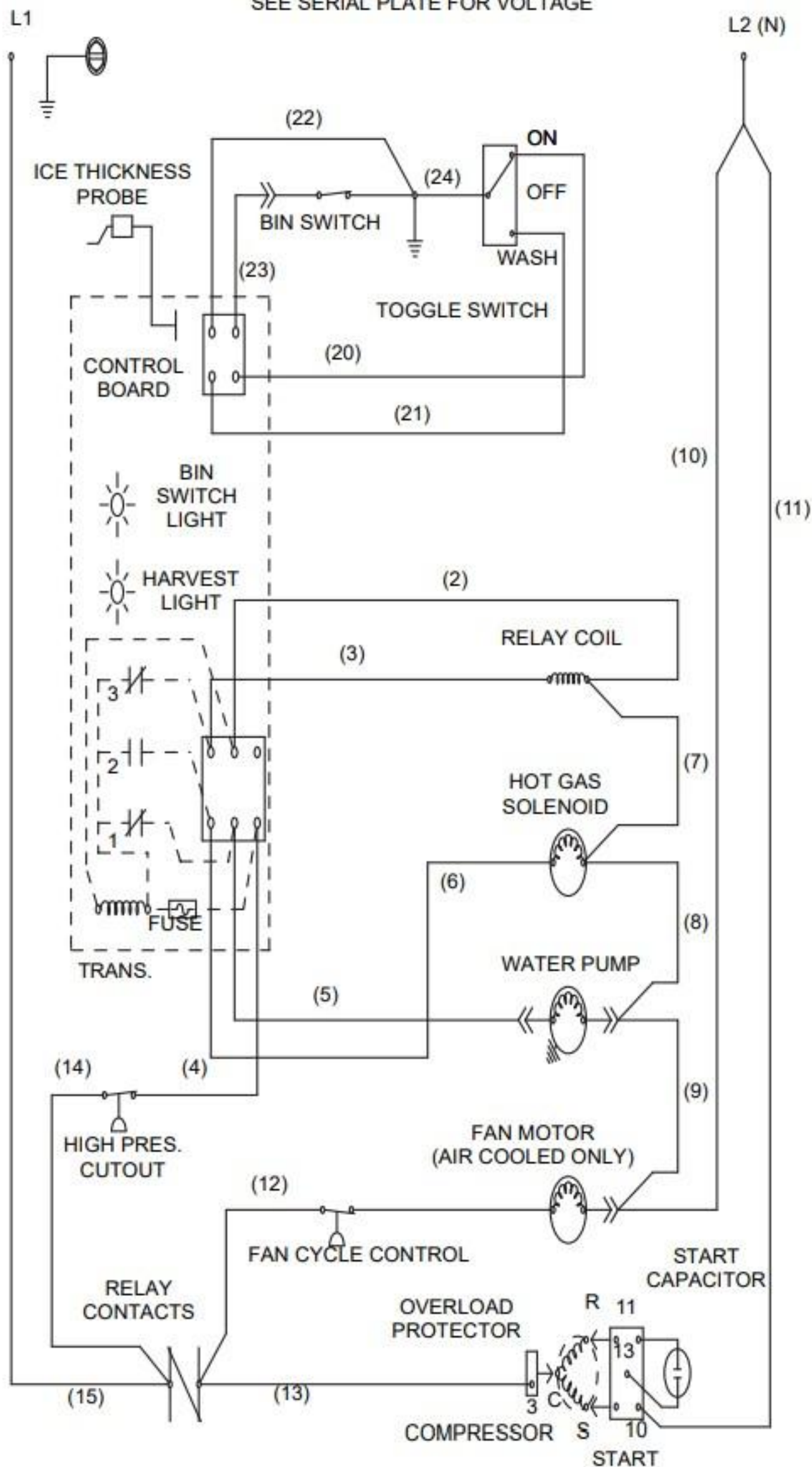



CAUTION: DISCONNECT POWER BEFORE WORKING ON ELECTRICAL CIRCUITRY.  
 NOTE: DIAGRAM SHOWN DURING THE FREEZE CYCLE.

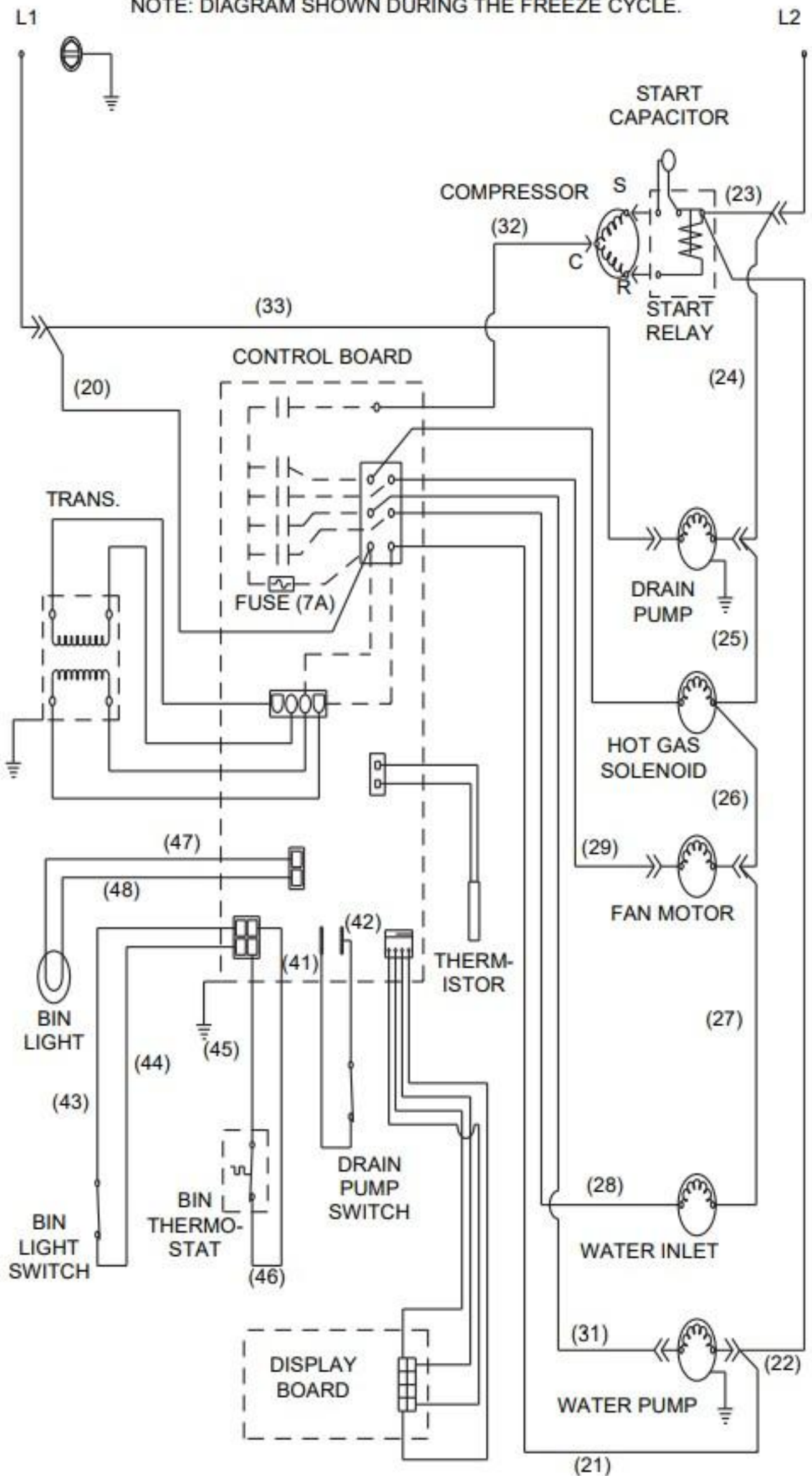

CAUTION: DISCONNECT POWER BEFORE WORKING ON ELECTRICAL CIRCUITRY.

NOTE: DIAGRAM SHOWN DURING THE FREEZE CYCLE. SEE SERIAL PLATE FOR VOLTAGE.

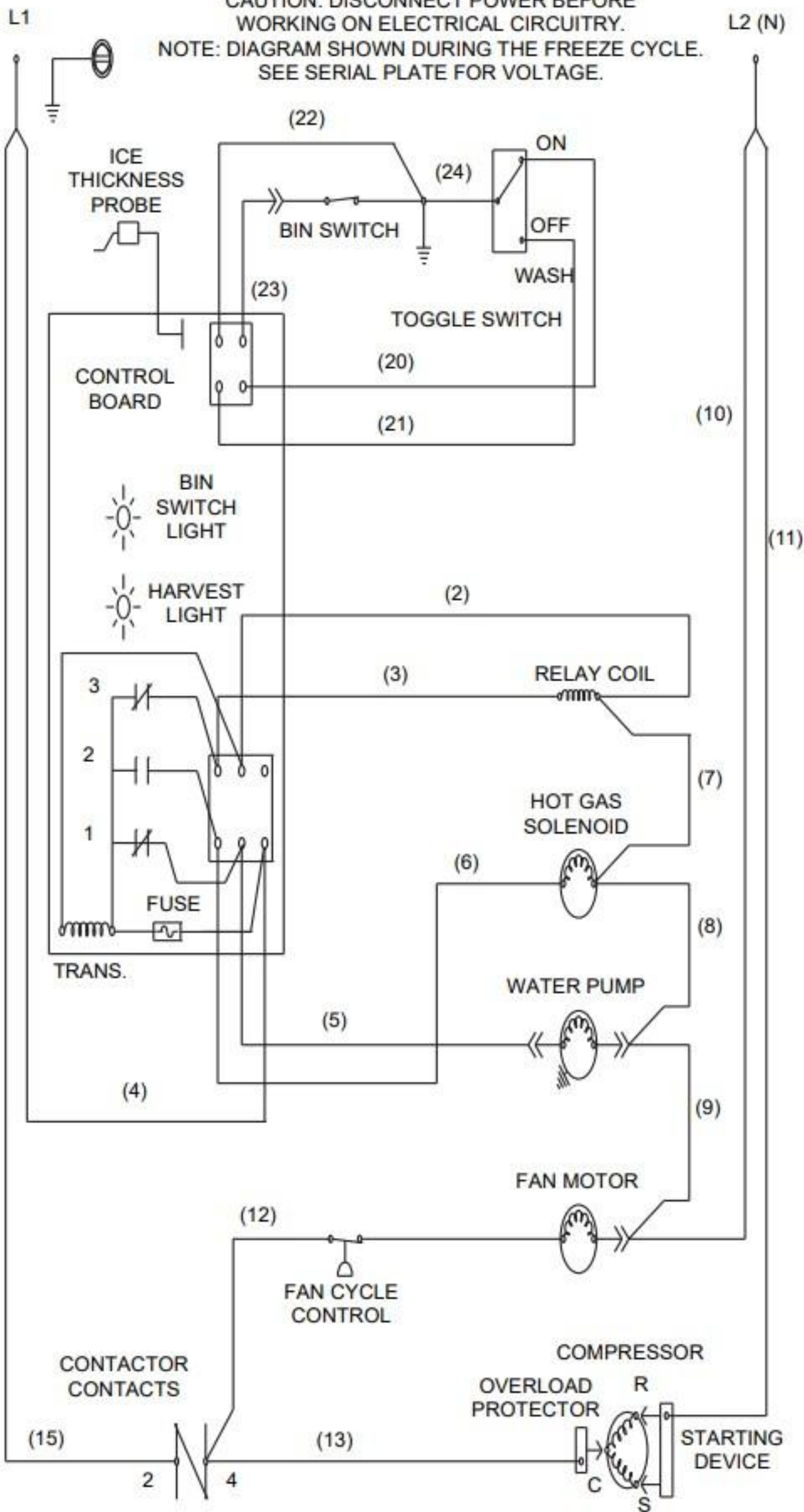

L1

L2 (N)

