

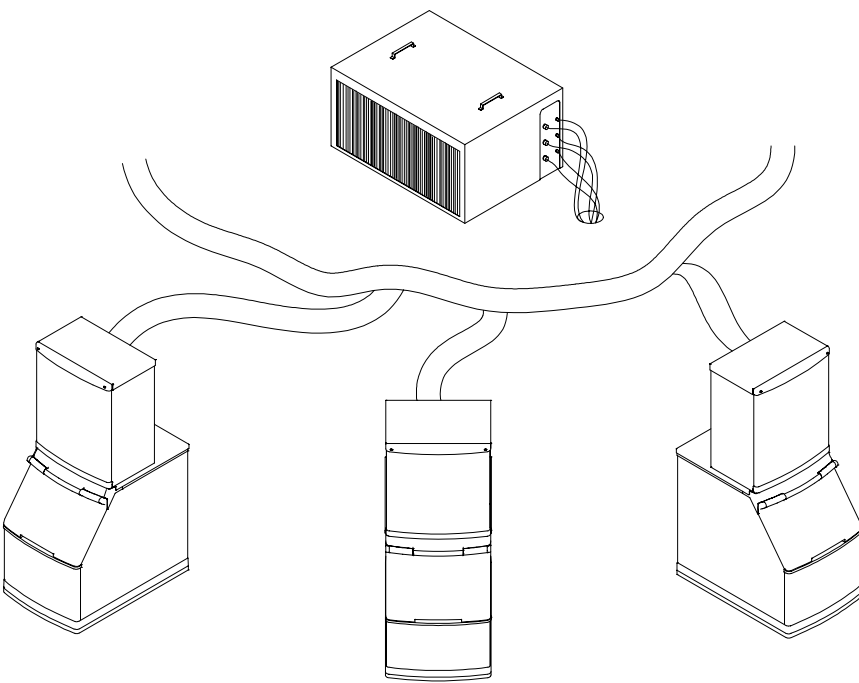

P Model Point of Use Ice Machine

Installation,
Use and Care,
and Service Manual



Thank you for selecting a Manitowoc Ice Machine, the dependability leader in ice making equipment and related products. With proper care and maintenance, your new Manitowoc Ice Machine will provide you with many years of reliable and economical performance.

Safety Notices

When using or servicing a P Model Ice Machine, be sure to pay close attention to the safety notices in this manual. Disregarding the notices may lead to serious injury and/or damage to the ice machine.

Throughout this manual, you will see the following types of safety notices:

WARNING

Text in a Warning box alerts you to a potential personal injury situation. Be sure to read the Warning statement, and then proceed carefully.

CAUTION

Text in a Caution box alerts you to a situation in which you could damage the ice machine. Be sure to read the Caution statement, and then proceed carefully.

CAUTION

Proper care and maintenance are essential for trouble-free operation of your Manitowoc Ice Machine.

Read and understand this manual. It contains valuable care and maintenance information. If you encounter problems not covered by this manual, feel free to contact Manitowoc Ice, Inc. We will be happy to provide assistance.

Procedural Notices

When using or servicing a P Model Ice Machine, be sure to read the procedural notices in this manual. These notices supply helpful and important information.

Throughout this manual, you will see the following types of procedural notices:

Important

Important boxes serve two functions.

They call the operator's attention to important information.

They also provide the service technician with information that may help in performing a procedure more efficiently. Disregarding this information may slow down the work.

NOTE: Text set off as a Note provides you with simple, but useful, extra information.

We reserve the right to make product improvements at any time.

Specifications and design are subject to change without notice.

MANITOWOC ICE, INC.

2110 South 26th Street P.O. Box 1720

Manitowoc, WI 54221-1720

Phone: (920) 682-0161

Service Fax: (920) 683-7585

Web Site: <http://www.manitowocice.com>

©1998 Manitowoc Ice, Inc.

Litho in USA

Table of Contents

Section 1 - General Information

Model Numbers 1-1
Accessories 1-1
Model/Serial Number Location..... 1-2
Owner Warranty Registration Card 1-3
Warranty Coverage..... 1-3

Section 2 - Installation Instructions

General 2-1
Ice Machine Dimensions 2-1
Location of Ice Machine 2-2
Location of Condensing Unit..... 2-2
Leveling the Ice Machine 2-2
Electrical Service 2-3
Water Service/Drains..... 2-4
Refrigerant Charge 2-5
Pre-Charged Lineset Installation
 Routing Pre-Charged Linesets..... 2-7
 Lengthening or Reducing Line Set Lengths 2-8
 Connecting a Lineset..... 2-9
 Lineset Service Valves..... 2-9
Installation Checklist 2-10
Before Starting the Ice Machine 2-10

Section 3 - Ice Machine Operation

Component Identification..... 3-1
Ice Making Sequence of Operation 3-2
Operational Checks..... 3-4

Section 4 - Maintenance

General 4-1
Ice Machine Inspection 4-1
Exterior Cleaning 4-1
Cleaning the Condenser..... 4-1
Interior Cleaning and Sanitizing 4-2
Removal of Parts for Cleaning/Sanitizing..... 4-4
Water Treatment/Filtration 4-9
Removal from Service/Winterization 4-10

Table of Contents

Table of Contents (cont.)

Section 5 - Before Calling for Service

Checklist.....	5-1
Safety Limit Stand-By Mode.....	5-2

Section 6 – Service

Energized Parts Chart	6-1
Main Fuse.....	6-2
Bin Switch	6-2
Toggle Switch.....	6-4
Harvest Heater Element	6-4
Harvest Heater Element Thermostat	6-5
Low Pressure Control	6-5
Suction Solenoid valve	6-6
Line Set Isolation valves	6-6
Evaporator removal.....	6-7
Control Board.....	6-8
Safety Limits.....	6-9
Ice Thickness Probe (Harvest Initiation)	
How the Probe Works.....	6-12
Harvest/Safety Limit Light.....	6-12
Freeze Time Lock-In Feature.....	6-12
Maximum Freeze Time.....	6-12
Ice Thickness Check.....	6-12
Diagnosing Ice Thickness Control Circuitry	
Ice Machine Does Not Cycle Into Harvest	6-13
Ice Machine Prematurely Cycles Into Harvest	6-14
Water Level Control Circuitry	
Water Level Probe Light.....	6-15
Freeze Cycle Water Level Setting.....	6-15
Water Inlet Valve Safety Shut-off	6-15
Freeze Cycle Circuitry.....	6-15
Harvest Cycle Circuitry.....	6-15
Diagnosing Freeze Cycle Potable Water Circuitry	
Water Trough Overflowing During The Freeze Cycle.....	6-16
Water Will Not Run Into The Sump Trough During The Freeze Cycle.....	6-18
Wiring Diagram.....	6-19
Tubing Schematic.....	6-20
24 Hour Production Graphs	
P520/P530.....	6-21

Section 1
General Information

Model Numbers

This manual covers the following models:

Ice Machine
PD0522N
PY0524N
PD0532N
PY0534N

Accessories

Contact your Manitowoc distributor for these optional accessories:

BIN CASTER

Replaces standard legs.

ICE BAGGER

Maximize profits from bagged ice sales with this convenient accessory. This sturdy unit rests on the bin door frame, and adapts for left or right side filling.

TRI-LIMINATOR WATER FILTER SYSTEM

Engineered specifically for Manitowoc ice machines, Tri-Liminator water filters are an efficient, dependable, and affordable method of inhibiting scale formation, filtering sediment, and removing chlorine taste and odor.

MANITOWOC CLEANER AND SANITIZER

Manitowoc Ice Machine Cleaner and Sanitizer are available in convenient 16 oz. (473 ml) bottles. These are the only cleaner and sanitizer approved for use with Manitowoc products.

DISPENSER

A counter-top dispenser is ideal for cafeterias and many types of self-service facilities. Manitowoc auto-fill, floor-standing ice dispensers meet the strict sanitary requirements of the food service, lodging, and health care industries.

Model/Serial Number Location

Record the model and serial number of your ice machine and bin or dispenser in the space provided below. These numbers are required when requesting information from your local Manitowoc distributor, service representative, or Manitowoc Ice, Inc.

The model and serial number are listed on the OWNER WARRANTY REGISTRATION CARD. They are also listed on the MODEL/SERIAL NUMBER DECAL affixed to the ice machine.

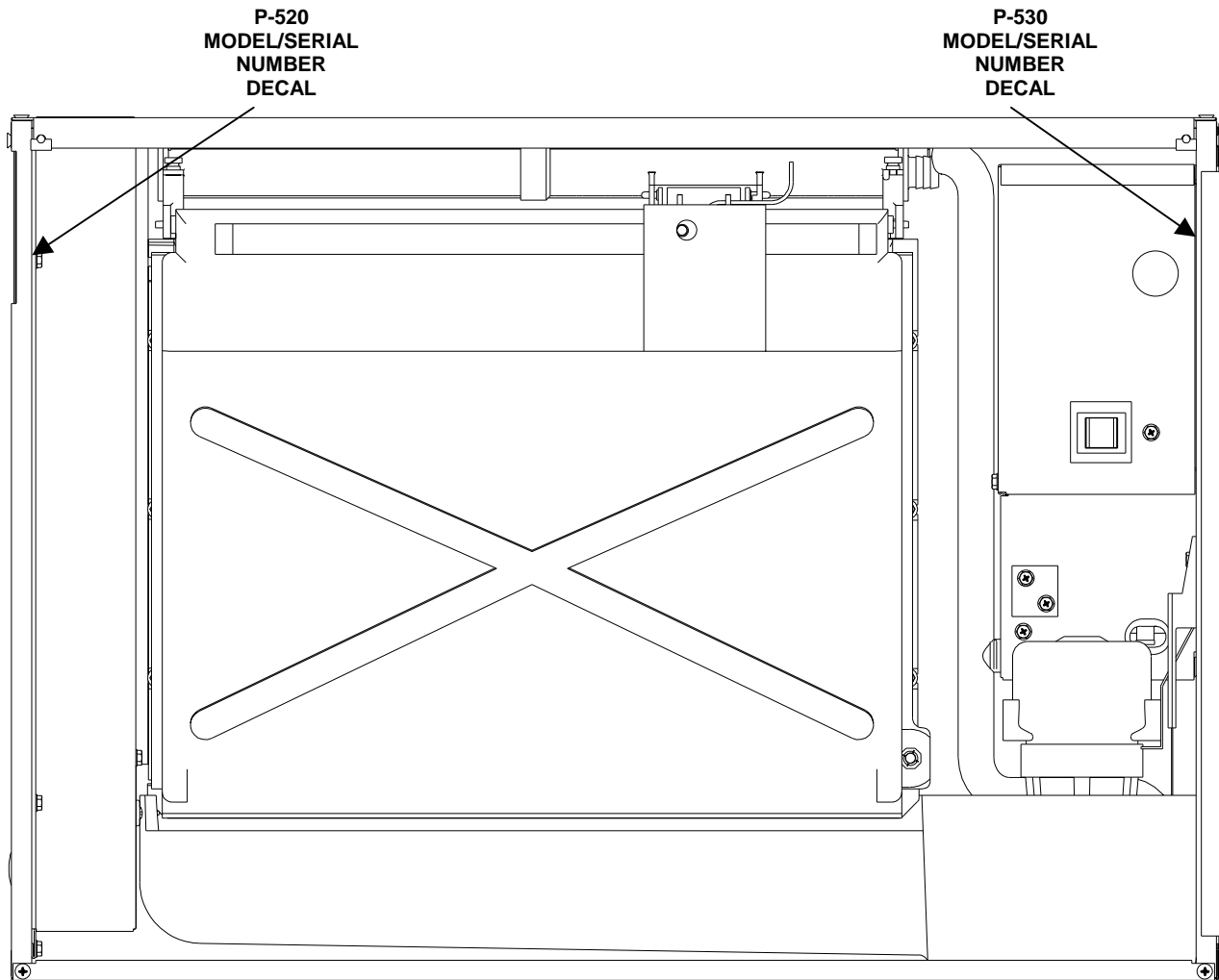

Model/Serial Number Location

SV1700A

Ice Machine	
Model Number	
Serial Number	
Model Number	
Serial Number	
Model Number	
Serial Number	
Model Number	
Serial Number	

Owner Warranty Registration Card

GENERAL

The packet containing this manual also includes warranty information. Warranty coverage begins the day your new ice machine is installed.

Important

Complete and mail the OWNER WARRANTY REGISTRATION CARD as soon as possible to validate the installation date.

If you do not return your OWNER WARRANTY REGISTRATION CARD, Manitowoc will use the date of sale to the Manitowoc Distributor as the first day of warranty coverage for your new ice machine.

Warranty Coverage

GENERAL

The following Warranty outline is provided for your convenience. For a detailed explanation, read the warranty bond shipped with each product.

Contact your local Manitowoc representative or Manitowoc Ice, Inc. if you need further warranty information.

Important

This product is intended exclusively for commercial application. No warranty is extended for personal, family, or household purposes.

ICE MACHINE PARTS

1. Manitowoc warrants the ice machine against defects in materials and workmanship, under normal use and service for three (3) years from the date of original installation.
2. The evaporator is covered by an additional two (2) year (five years total) warranty beginning on the date of the original installation.

ICE MACHINE LABOR

1. Labor required to repair or replace defective components is covered for three (3) years from the date of original installation.
2. The evaporator is covered by an additional two (2) year (five years total) labor warranty beginning on the date of the original installation.

CONDENSING UNIT WARRANTY

Condensing units (compressor ect.) are not covered under Manitowoc's warranty. Process all claims following the condenser manufactures guidelines.

EXCLUSIONS

The following items are not included in the ice machine's warranty coverage:

1. Condensing unit parts (compressor ect) or repairs. Contact the condensing unit manufacturer for warranty information.
2. Normal maintenance, adjustments and cleaning as outlined in this manual.
3. Repairs due to unauthorized modifications to the ice machine or use of non-standard parts without prior written approval from Manitowoc Ice, Inc.
4. Damage caused by improper installation of the ice machine, electrical supply, water supply or drainage, or damage caused by floods, storms, or other acts of God.
5. Premium labor rates due to holidays, overtime, etc.; travel time; flat rate service call charges; mileage and miscellaneous tools and material charges not listed on the payment schedule. Additional labor charges resulting from the inaccessibility of equipment are also excluded.
6. Parts or assemblies subjected to misuse, abuse, neglect or accidents.
7. Damage or problems caused by installation, cleaning and/or maintenance procedures inconsistent with the technical instructions provided in this manual.
8. This product is intended exclusively for commercial application. No warranty is extended for personal, family, or household purposes.

AUTHORIZED WARRANTY SERVICE

To comply with the provisions of the warranty, a refrigeration service company, qualified and authorized by your Manitowoc distributor, or a Contracted Service Representative must perform the warranty repair.

NOTE: If the dealer you purchased the ice machine from is not authorized to perform warranty service, contact your Manitowoc distributor or Manitowoc Ice, Inc. for the name of the nearest authorized service representative.

Service Calls

Normal maintenance, adjustments and cleaning as outlined in this manual are not covered by the warranty. If you have followed the procedures listed on page 5-1 of this manual, and the ice machine still does not perform properly, call your authorized service company.

THIS PAGE INTENTIONALLY LEFT BLANK

Section 2 Installation Instructions

General

These instructions are provided to assist the qualified installer. Check your local Yellow Pages for the name of the nearest Manitowoc distributor, or call Manitowoc Ice, Inc. for information regarding start-up services.

Important
Failure to follow these installation guidelines may affect warranty coverage.

Ice Machine Dimensions

P-520 ICE MACHINE

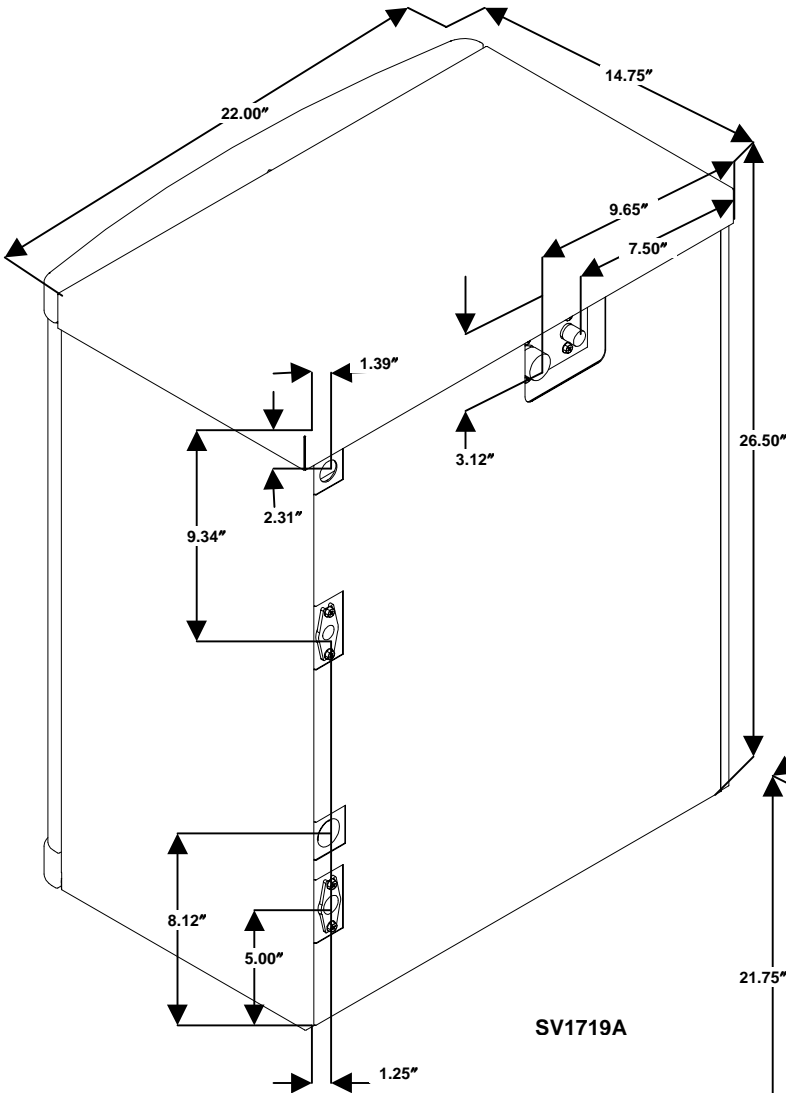

SV1719A

P-530 ICE MACHINE

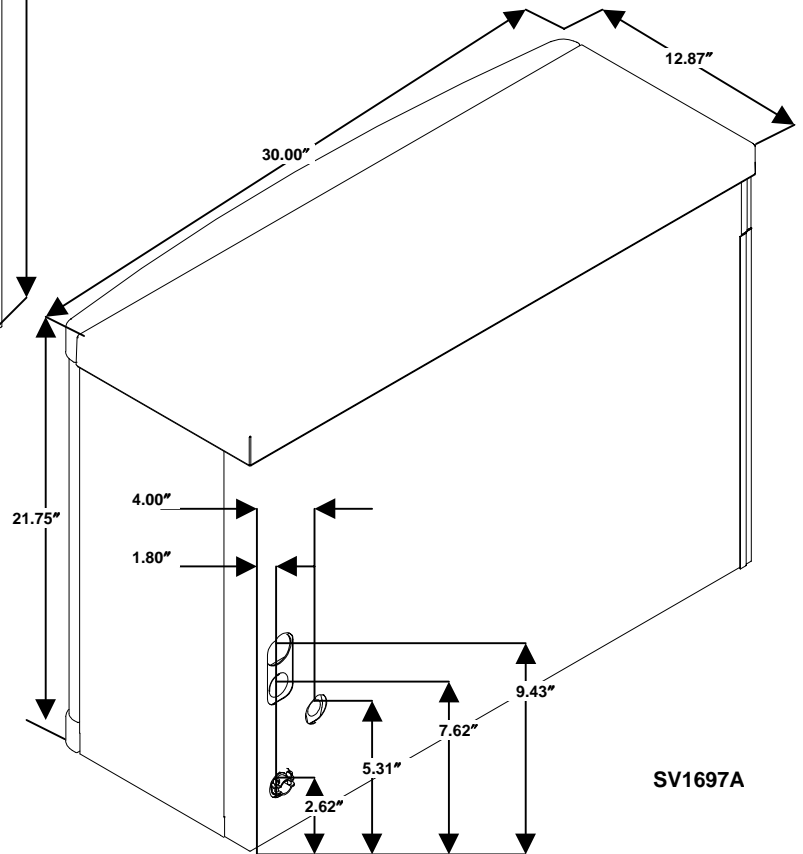

SV1697A

Location of Ice Machine

The location selected for the ice machine must meet the following criteria. If any of these criteria are not met, select another location.

- The location must be free of airborne and other contaminants.
- The air temperature must be at least 35°F (1.6°C), but must not exceed 110°F (43.4°C).
- The location must not be near heat-generating equipment or in direct sunlight.

	Ice Machine Head Section
Top/Sides	5" (127 mm)*
Back	5" (127 mm)*

There is no minimum clearance required. This value is recommended for servicing only.

CAUTION

The ice machine must be protected if it will be subjected to temperatures below 32°F (0°C). Failures caused by exposure to freezing temperatures are not covered by the warranty. See "Removal from Service/Winterization" on page 4-10.

Location of Condensing Unit

The location selected for the condensing unit must meet the following criteria. If any of these criteria are not met, select another location.

- The location must allow connection of all pre-charged line sets, with out exceeding total distance, rise or drop guidelines. (see page 2-7)
- Refer to the manual supplied with the condensing unit, for Copeland's clearance requirements.

Leveling the Ice Machine

1. Screw the leveling legs onto the bottom of the bin.
2. Screw the foot of each leg in as far as possible.

CAUTION

The legs must be screwed in tightly to prevent them from bending.

3. Move the bin into its final position.
4. Level the bin to assure that the bin door closes and seals properly. Use a level on top of the bin. Turn each foot as necessary to level the bin.

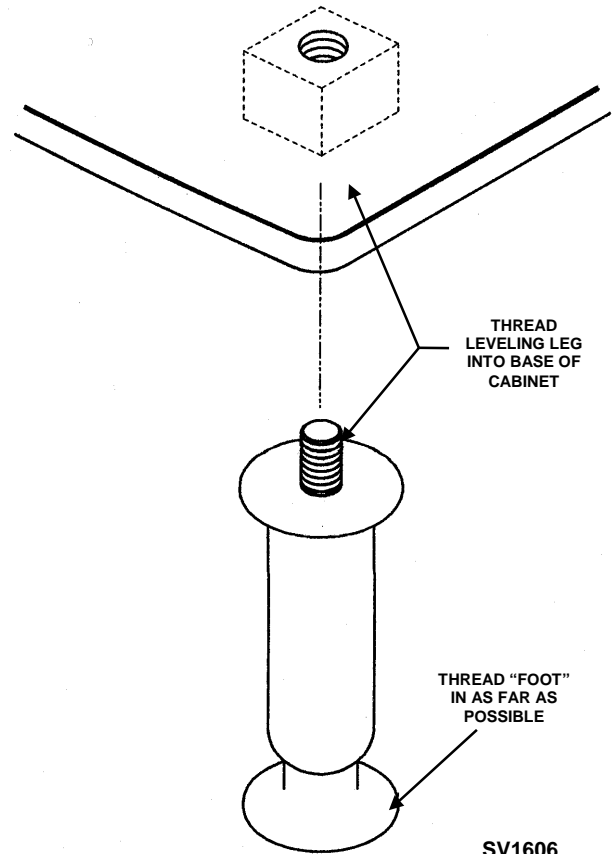

SV1606

Leveling Leg and Foot

Electrical Service

GENERAL



WARNING

All wiring must conform to local, state and national codes.

VOLTAGE

The maximum allowable voltage variation is $\pm 10\%$ of the rated voltage at compressor start-up (when the electrical load is highest).



WARNING

The ice machine must be grounded in accordance with national and local electrical codes.

FUSE/CIRCUIT BREAKER

A separate fuse/circuit breaker must be provided for each ice machine. Circuit breakers must be H.A.C.R. rated (does not apply in Canada).

MINIMUM CIRCUIT AMPACITY

The minimum circuit ampacity is used to help select the wire size of the electrical supply. (Minimum circuit ampacity is not the ice machine's running amp load).

The wire size (or gauge) is also dependent upon location, materials used, length of run, etc., so it must be determined by a qualified electrician.

P-520 - P-530 - ICE MACHINES

Ice Machine	Voltage/Phase/Cycle	Maximum Fuse/Circuit Breaker	Minimum Circuit Amps
P-520 and P-530	115/1/60	20	16

CONDENSING UNIT

Refer to nameplate for correct voltage and amperage ratings.

Scroll compressors will compress in one direction of rotation only. Three phase compressor motors are capable of running in either direction. Interchanging any two of the three main power leads will reverse the direction of rotation.

Verifying 3 Phase Direction of Rotation

Complete the entire installation of the ice machines and condensing unit. Energize one ice machine and the condensing unit, and monitor the suction and discharge pressures.

Symptoms of incorrect 3 phase rotation:

1. Noisy compressor operation.
2. Low amp draw
3. Elevated suction pressure.
4. Decreased head pressure



CAUTION

Verify correct compressor rotation on three phase units.

Water Service/Drains

WATER SUPPLY

Local water conditions may require treatment of the water to inhibit scale formation, filter sediment, and remove chlorine odor and taste.

Important

If you are installing a Manitowoc Tri-Liminator water filter system, refer to the Installation Instructions supplied with the filter system for ice making water inlet connections.

WATER INLET LINES

Follow these guidelines to install water inlet lines:

- Do not connect the ice machine to a hot water supply. Be sure all hot water restrictors installed for other equipment are working. (Check valves on sink faucets, dishwashers, etc.)
- If water pressure exceeds the maximum recommended pressure, obtain a water pressure regulator from your Manitowoc distributor.
- Install a water shut-off valve for the ice making water line.
- Insulate water inlet lines to prevent condensation.

DRAIN CONNECTIONS

Follow these guidelines when installing drain lines to prevent drain water from flowing back into the ice machine and storage bin:

- Drain lines must have a 1.5-inch drop per 5 feet of run (2.5 cm per meter), and must not create traps.
- The floor drain must be large enough to accommodate drainage from all drains.
- Run separate bin and ice machine drain lines. Insulate them to prevent condensation.
- Vent the bin and ice machine drain to the atmosphere.

WATER SUPPLY AND DRAIN LINE SIZING/CONNECTIONS



CAUTION

Plumbing must conform to state and local codes.

Location	Water Temperature	Water Pressure	Ice Machine Fitting	Tubing Size Up to Ice Machine Fitting
Ice Making Water Inlet	33°F (0.6°C) Min. 90°F (32.2°C) Max.	20 psi (137.9 kPA) Min. 80 psi (551.5 kPA) Max.	3/8" Female Pipe Thread	3/8" (9.5 mm) minimum inside diameter
Ice Making Water Drain	---	---	1/2" Female Pipe Thread	1/2" (12.7 mm) minimum inside diameter
Bin Drain	---	---	3/4" Female Pipe Thread	3/4" (19.1 mm) minimum inside diameter

REFRIGERANT CHARGE

The Copeland condensing unit ships from the factory with a refrigerant charge appropriate for installation with three ice machines, and line sets of up to 50' (15.25 m) per ice machine.

The model/serial nameplate on the ice machine indicates the refrigerant type.

Additional refrigerant is required for installations using four ice machines.

The receiver is designed to hold a charge sufficient to operate the ice machine in ambient temperatures between -20°F (-28.9°C) and 120°F (54.4°C), with line set lengths of up to 50' per ice machine.

CAUTION

Do not operate condensing unit without first connecting tubing and Ice Machines to all aeroquip fittings. The diaphragm on the aeroquip fitting is not designed for extended use at high system pressures, and could result in a refrigerant Leak.

FOUR ICE MACHINE INSTALLATIONS

When connecting a fourth ice machine:

- Refrigeration systems and compressors with POE oil must not be left open to the atmosphere for more than 15 minutes. Open system just prior to brazing and be prepared to hook up a vacuum pump immediately after brazing.
- Recover the refrigerant charge in the condensing unit.
- Braze tubing for the additional ice machine to the manifold assembly.
- Replace the condensing unit line drier.
- Perform a leak test, evacuate system to 250 microns, and weigh in the correct refrigerant charge.

Model	Total refrigerant amount (R-404A) as shipped from factory.	Additional Refrigerant to be added for fourth ice machine	Maximum system charge (Never exceed)
P520/530 3 Ice Machines and 20' to 50' of tubing per ice machine	16.5 lbs. (264 oz.)	None	16.5 lbs. (264 oz.)
P520/P530 4 Ice Machines and 20' to 50' of tubing per ice machine	16.5 lbs. (264 oz.)	3.0 lbs. (48 oz.)	19.5 lbs. (312 oz.)
When utilized with Copeland condensing unit VJAL-022Z-CFV-051 or VJAL-022Z-TFC-051			

Line Set Installation

Ice Machine	Line Set*	
P520 and P530	PT-20-R404A PT-35-R404A PT-50-R404A	
*Line Set	Suction Line	Liquid Line
PT	1/2" (12.7 mm)	1/4" (6.4 mm)

ROUTING PRE-CHARGED LINE SETS

General

Remote condensing unit installations consist of vertical and horizontal line set distances between the ice machine and the condensing unit. When combined, they must fit within approved specifications. The following guidelines, drawings and calculation methods must be followed to verify a proper installation.

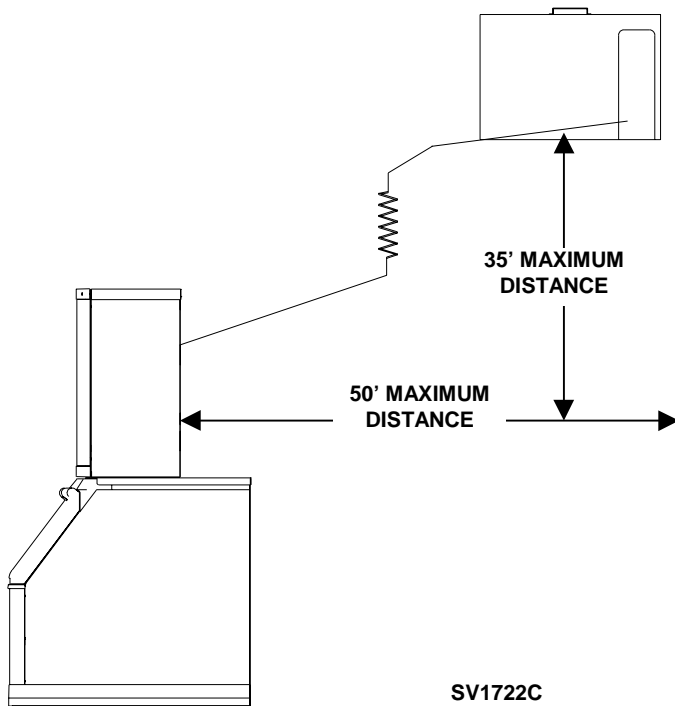

Maximum line set distance is 50' per ice machine.
Maximum line set rise is 35' per ice machine.
Maximum line set drop is 35' per ice machine.

Any line set routed below the condensing unit is considered drop.

Any line set routed above the condensing unit is considered rise.

Line set rise, drop, horizontal runs (or combinations of these) in excess of the stated maximums will exceed compressor start-up and design limits. This will cause poor oil return to the compressor.

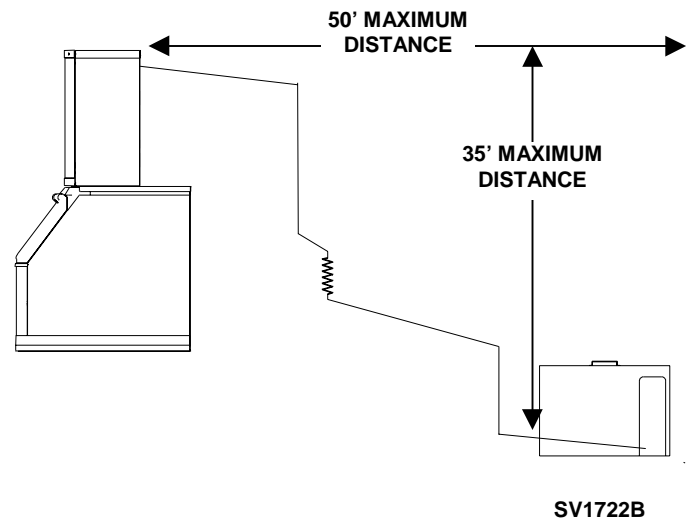

Guidelines for Routing Pre-Charged Line Sets

First cut a circular hole in the wall or roof for tubing routing. It is recommended that the line set end with the service valves be connected to the ice machine. The straight end will connect to the condensing unit manifold.

Follow these guidelines when routing the refrigerant lines. This will help insure proper performance and service accessibility.

1. When installing horizontal runs refrigerant oil must be free to return to the condensing unit. Pitch all suction lines in the direction of refrigerant flow (toward condensing unit), allowing a minimum of 1/2" drop per 10' of horizontal run.
2. Route excess tubing in a supported downward horizontal spiral as shown below. Do not coil tubing vertically.
3. Insulate all suction lines, suction line shut-off valves and components, to prevent condensation and sweating.
4. Keep outdoor refrigerant line runs as short as possible.

CAUTION

If a line set has a rise followed by a drop, another rise cannot be made. Likewise, if a line set has a drop followed by a rise, another drop cannot be made.

LENGTHENING OR REDUCING LINE SET LENGTHS

In most cases, by routing the line set properly, shortening will not be necessary. When shortening or lengthening is required, do so before connecting the line set to the ice machine or condensing unit. This prevents the loss of refrigerant.

The quick connect fittings on the line sets are equipped with Schraeder valves. Use these valves to recover any vapor charge from the line set. When lengthening or shortening lines, follow good refrigeration practices and insulate new tubing. Do not change the tube sizes. Evacuate the lines and place about 5-oz (142g) of vapor refrigerant charge in each line.

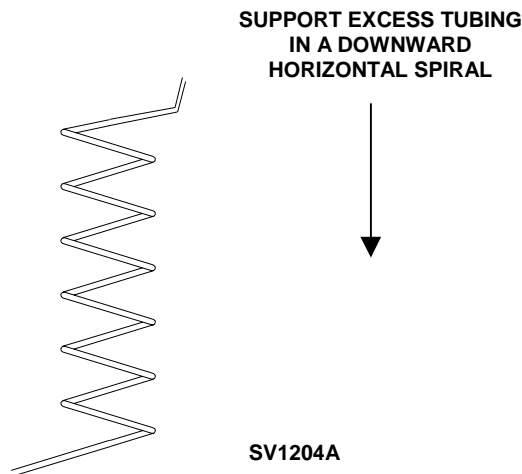

CONNECTING A LINE SET

1. Remove the dust caps from the line set, manifold and ice machine.
2. Apply refrigeration oil to the threads on the quick disconnect couplers before connecting.
3. Carefully thread the female fitting by hand, to insure proper mating of the threads.
4. Tighten the couplings with a wrench until they bottom out.
5. Turn an additional 1/4 turn to ensure proper brass-to-brass seating. Torque to the following specifications:

Liquid Line	Suction Line
10-12 ft lb. (13.5-16.2 N•m)	35-45 ft lb. (47.5-61.0 N•m)

6. Check all fittings for leaks.

LINE SET SERVICE VALVE

Lines set service valves leave the factory in the open position.

Verify all line set service valves are open and insulated.

Important

Check condensing unit manual instructions to verify that the receiver, suction and liquid line service valves are in the open (backseated) position.

Installation Checklist

- Is the ice machine level?
- Has all of the internal packing been removed?
- Have all of the electrical and water connections been made?
- Has the supply voltage been tested and checked against the rating on the nameplate?
- Is there proper clearance around the ice machine for servicing?
- Has the ice machine been installed where ambient temperatures will remain in the range of 35° - 110°F (1.7° - 43.3°C)?
- Has the ice machine been installed where the incoming water temperature will remain in the range of 33° - 90°F (0.6° - 32.2°C)?
- Are the ice machine and bin drains vented?
- Has the line set and condensing unit service valves been opened?
- Do the condenser fan motors operate properly?
- Has the remote condenser been located where ambient temperatures will remain in the range of -10° to 120°F (-6.6° to -49°C)?
- Are the refrigeration lines run correctly?
- Are all electrical leads free from contact with refrigeration lines and moving equipment?
- Has the owner/operator been instructed regarding maintenance and the use of Manitowoc Cleaner and Sanitizer?
- Has the owner/operator completed the warranty registration card?
- Has the ice machine and bin been sanitized?

Before Starting the Ice Machine

All Manitowoc ice machines are factory-operated and adjusted before shipment. Normally, new installations do not require any adjustment.

To ensure proper operation, follow the Operational Checks on page 3-4 of this manual. Starting the ice machine and completing the Operational Checks are the responsibilities of the owner/operator.

ADJUSTMENTS AND MAINTENANCE PROCEDURES OUTLINED IN THIS MANUAL ARE NOT COVERED BY THE WARRANTY.

AuCS[®] Automatic Cleaning System

This optional accessory monitors ice-making cycles and initiates self-cleaning procedures automatically. The AuCS[®] accessory can be set to automatically clean or sanitize the ice machine every 2, 4 or 12 weeks. Refer to the AuCS[®] Installation and Owner/Operator Use and Care Guide for details.

Section 3
Ice Machine Operation

COMPONENT IDENTIFICATION

P520

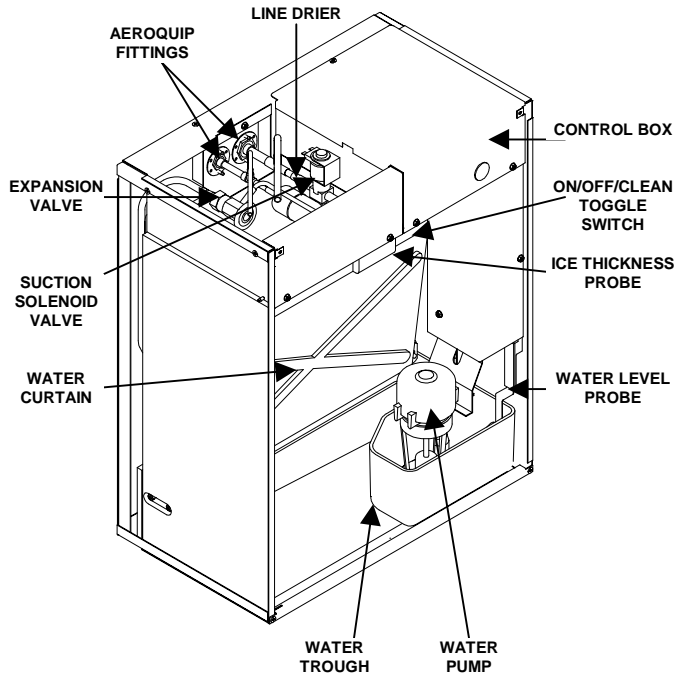

SV1718A

P530

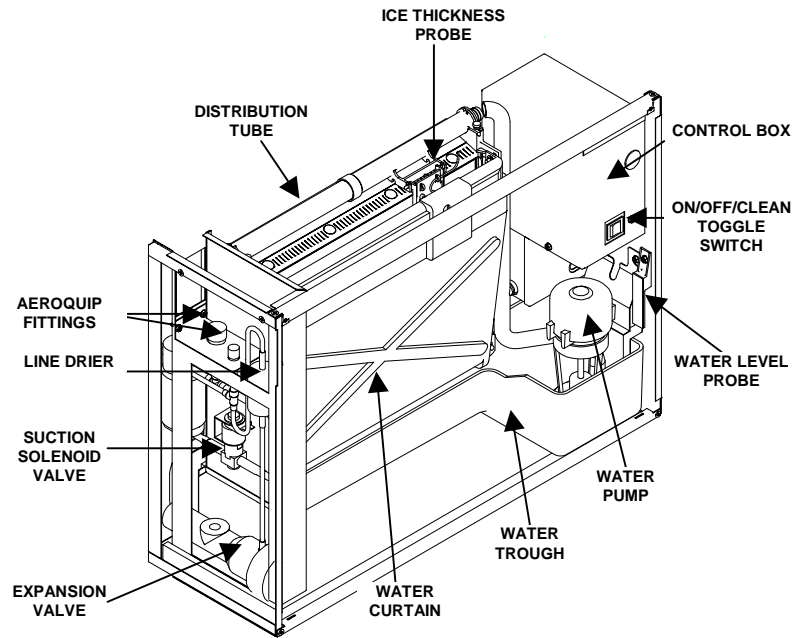

SV1696A

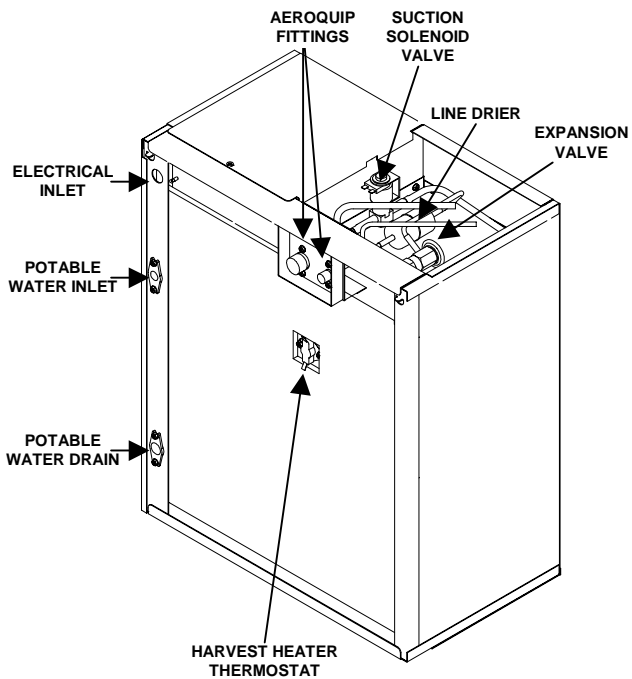

SV1720A

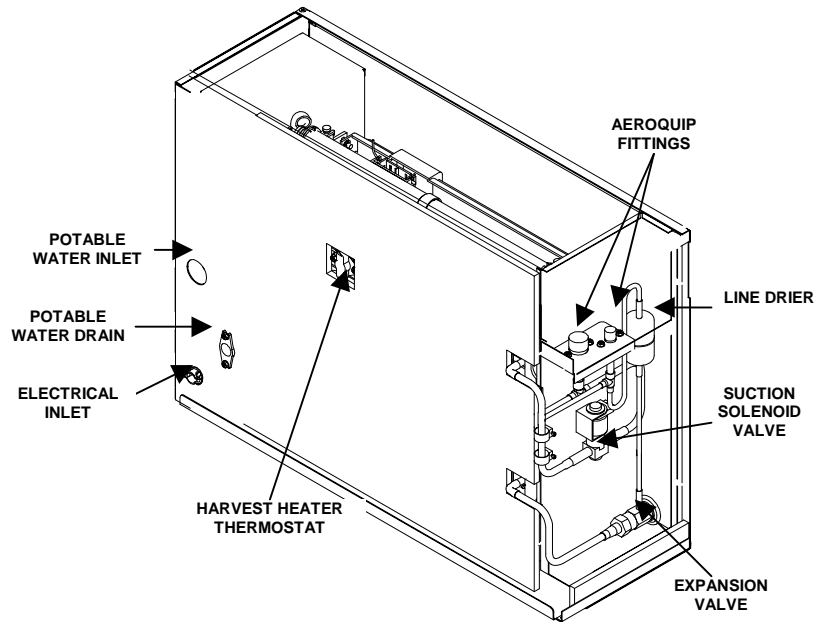

SV1698A

INITIAL START-UP OR START-UP AFTER AUTOMATIC SHUT-OFF

1. Water Purge

Before refrigeration begins the water pump and water dump solenoid are energized for 45 seconds, to completely purge the ice machine of old water. This feature ensures that the ice making cycle starts with fresh water.

FREEZE SEQUENCE

2. Prechill

The suction line solenoid is on (refrigerant starts to flow) for 30 seconds prior to water flow, to prechill the evaporator. The water fill valve turns on and remains on until the water level probe is satisfied.

3. Freeze

The water pump restarts after the 30 second prechill. An even flow of water is directed across the evaporator and into each cube cell, where it freezes. The water fill valve will cycle on and then off one more time to refill the water trough.

When sufficient ice has formed, the water flow (not the ice) contacts the ice thickness probe. After approximately 10 seconds of continual water contact, the harvest sequence is initiated. The ice machine cannot initiate a harvest sequence until a 6-minute freeze lock has been surpassed.

Ice Making Sequence of Operation

HARVEST SEQUENCE

4. Water purge

The water pump continues to run and the water dump valve energizes for 45 seconds, to purge the water in the sump trough. The water fill valve energizes for the last 15 seconds of the 45-second water purge. After the 45 second water purge, the water pump, water fill valve, and water dump valve de-energize.

The evaporator heaters energize at the beginning of the water purge, to warm the evaporator.

The suction line solenoid de-energizes at the beginning of the water purge, to stop refrigerant flow into the evaporator.

5. Harvest

The evaporator heaters remain energized to warm the evaporator, causing the cubes to slide as a sheet off the evaporator and into the storage bin. The sliding sheet of cubes swings the water curtain out, opening the bin switch. The momentary opening and re-closing of the bin switch terminates the harvest sequence and returns the ice machine to the freeze sequence (steps 2-3).

AUTOMATIC SHUT-OFF

6. AUTOMATIC SHUT-OFF

When the storage bin is full at the end of a harvest sequence, the sheet of cubes fails to clear the water curtain and will hold it open. After the water curtain is held open for 7 seconds, the ice machine shuts off.

The ice machine remains off until enough ice has been removed from the storage bin to allow the ice to fall clear of the water curtain. As the water curtain swings back to the operating position, the bin switch re-closes and the ice machine restarts (step 1).

THIS PAGE INTENTIONALLY LEFT BLANK

Operational Checks

GENERAL

Your Manitowoc ice machine was factory-operated and adjusted before shipment. Normally, a newly installed ice machine does not require any adjustment.

To ensure proper operation, always follow these Operational Checks when starting the ice machine:

- for the first time
- after a prolonged out of service period
- after cleaning and sanitizing

Routine adjustments and maintenance procedures outlined in this manual are not covered by the warranty.

WATER LEVEL

The water level sensor is set to maintain the proper water level above the water pump housing. The water level is not adjustable.

If the water level is incorrect, check the water level probe for damage (probe bent, etc.). Repair or replace the probe as necessary.

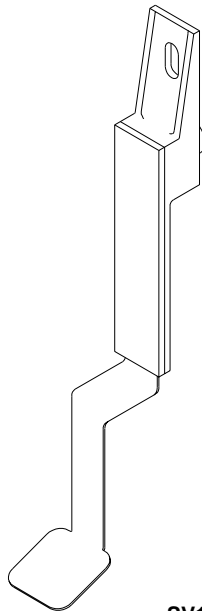

SV1707A

Water Level Probe

ICE THICKNESS CHECK

The ice thickness probe is factory-set to maintain the ice bridge thickness at 1/8" (3.2 mm).

NOTE: Make sure the water curtain is in place when performing this check. It prevents water from splashing out of the water trough.

1. Inspect the bridge connecting the cubes. It should be about 1/8" (3.2 mm) thick.
2. If adjustment is necessary, turn the ice thickness probe adjustment screw clockwise to increase bridge thickness, or counterclockwise to decrease bridge thickness.

NOTE: Turning the adjustment 1/3 of a turn will change the ice thickness about 1/16" (1.5 mm).

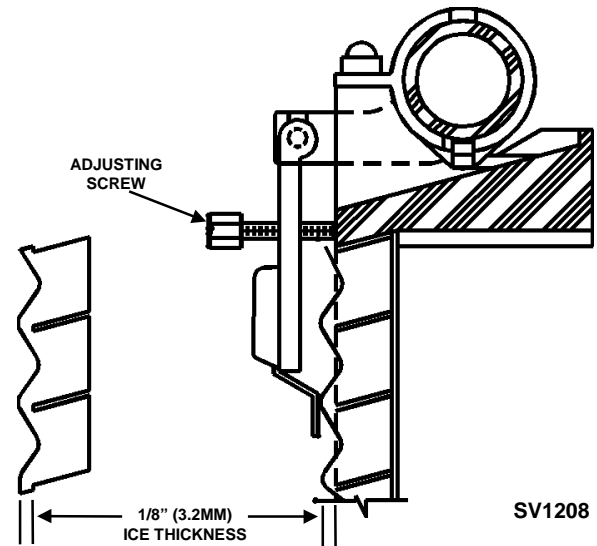

SV1208

Ice Thickness Adjustment

Make sure the ice thickness probe wire and the bracket do not restrict movement of the probe.

HARVEST SEQUENCE WATER PURGE

The harvest sequence water purge adjustment may be used when the ice machine is hooked up to special water systems, such as a de-ionized water treatment system.

Important

The harvest sequence water purge is factory-set at 45 seconds. A shorter purge setting (with standard water supplies such as city water) is not recommended. This can increase water system cleaning and sanitizing requirements.

- The harvest sequence water purge may be set to 15, 30, or 45 seconds.
- During the harvest sequence water purge, the water fill valve energizes and de-energizes by time. The water purge must be at the factory setting of 45 seconds for the water fill valve to energize during the last 15 seconds of the water purge. If it is set to less than 45 seconds, the water fill valve will not energize during the water purge.

WARNING

Disconnect the electrical power to the ice machine at the electrical disconnect before proceeding.

For your safety, and to eliminate errors, we recommend that a qualified service technician make the harvest water purge adjustment.

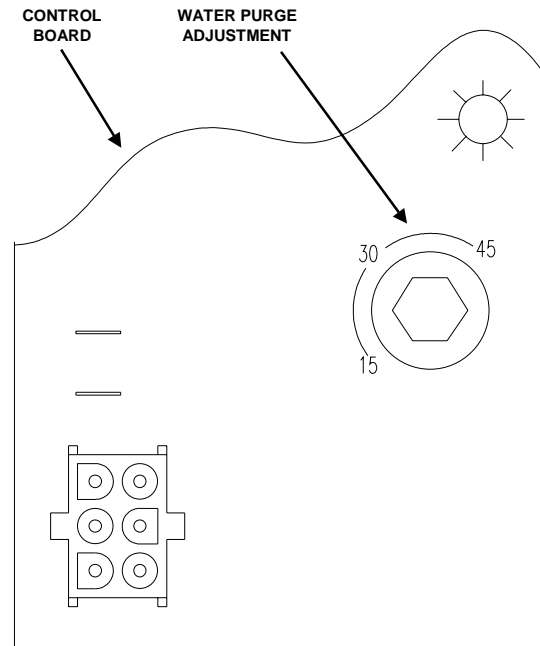

Water Purge Adjustment

SV1617

THIS PAGE INTENTIONALLY LEFT BLANK

Section 4 Maintenance

General

You are responsible for maintaining the ice machine in accordance with the instructions in this manual. Maintenance procedures are not covered by the warranty.

 **WARNING**

If you do not understand the procedures or the safety precautions that must be followed, call your local Manitowoc service representative to perform the maintenance procedures for you.

We recommend that you perform the following maintenance procedures every six months to ensure reliable, trouble-free operation and maximum ice production.

Ice Machine Inspection

 **WARNING**

Disconnect electric power to the ice machine and the remote condenser at the electric service switch before cleaning the condenser.

Check all water fittings and lines for leaks. Also, make sure the refrigeration tubing is not rubbing or vibrating against other tubing, panels, etc.

Exterior Cleaning

Clean the area around the ice machine as often as necessary to maintain cleanliness and efficient operation.

Sponge any dust and dirt off the outside of the ice machine with mild soap and water. Wipe dry with a clean, soft cloth.

Heavy stains should be removed with stainless steel wool. Never use plain steel wool or abrasive pads. They will scratch the panels.

Cleaning the Condenser

 **WARNING**

Disconnect electric power to the ice machine and the remote condensing unit at the electric service switch before cleaning the condenser.

A dirty condenser restricts airflow, resulting in excessively high operating temperatures. This reduces ice production and shortens component life. Refer to Copeland's cleaning instructions for details.

Interior Cleaning and Sanitizing

GENERAL

Clean and sanitize the ice machine every six months for efficient operation. If the ice machine requires more frequent cleaning and sanitizing, consult a qualified service company to test the water quality and recommend appropriate water treatment. If required, an extremely dirty ice machine may be taken apart for cleaning and sanitizing.

 **CAUTION**

Use only Manitowoc approved Ice Machine Cleaner (part number 94-0546-3) and Sanitizer (part number 94-0565-3). It is a violation of Federal law to use these solutions in a manner inconsistent with their labeling. Read and understand all labels printed on bottles before use.

 **CAUTION**

Do not mix Ice Machine Cleaner and Sanitizer solutions together. It is a violation of Federal law to use these solutions in a manner inconsistent with their labeling.

 **WARNING**

Wear rubber gloves and safety goggles (and/or face shield) when handling Ice Machine Cleaner or Sanitizer.

SELF-CLEANING PROCEDURE (SeCS®)

Ice machine cleaner is used to remove lime scale or other mineral deposits. It is not used to remove algae or slime. Refer to “Self-Sanitizing Procedure” on the next page for removal of algae and slime.

Step 1 Set the toggle switch to the OFF position after ice falls from the evaporator at the end of a Harvest cycle. Or, set the switch to the OFF position and allow the ice to melt off the evaporator.

 **CAUTION**

Never use anything to force ice from the evaporator. Damage may result.

Step 2 To start self-cleaning, move the toggle switch to the CLEAN position.

Step 3 Add the proper amount of Manitowoc Ice Machine Cleaner to the water trough.

Model	Amount of Cleaner
P-520/P-530	5 ounces (150 ml)

Step 4 The ice machine will automatically time out a ten-minute cleaning cycle, followed by six rinse cycles, and then stop. This entire cycle lasts approximately 25 minutes.

Step 5 When the self-cleaning process stops, move the toggle switch to the OFF position. Refer to “Self-Sanitizing Procedure” on the next page.

Step 6 The ice machine may be set to start and finish a self-cleaning procedure, and then automatically start ice making again.

- A. Wait about one minute into the self-cleaning cycle, then move the toggle switch from CLEAN to ICE position.
- B. When the self-cleaning cycle is completed, an ice making sequence will start automatically.

SELF-SANITIZING PROCEDURE

Use sanitizer to remove algae or slime. Do not use it to remove lime scale or other mineral deposits.

Step 1 Set the toggle switch to the OFF position after ice falls from the evaporator at the end of a Harvest cycle. Or, set the switch to the OFF position and allow the ice to melt off the evaporator.

**CAUTION**

Never use anything to force ice from the evaporator. Damage may result.

Step 2 To start self-sanitizing, move the toggle switch to the CLEAN position.

Step 3 Add the proper amount of Manitowoc Ice Machine Sanitizer to the water trough.

Model	Amount of Sanitizer
P-520/P-530	3 ounces (90 ml)

Step 4 The ice machine will automatically time out a ten-minute sanitizing cycle, followed by six rinse cycles, and then stop. This entire cycle lasts approximately 25 minutes.

Note: If the bin requires sanitizing, remove all of the ice and sanitize it with a solution of 1 ounce (30 ml) of sanitizer with up to 4 gallons (15 L) of water.

Step 5 When the self-sanitizing process stops, move the toggle switch to the ICE position to start making ice again.

Step 6

- A. The ice machine may be set to start and finish a self-sanitizing procedure, and then automatically start ice making again.
- B. Wait about one minute into the sanitizing cycle, then move the toggle switch from CLEAN to ICE position.
- C. When the self-sanitizing cycle is completed, an ice making sequence will start automatically.

Removal of Parts for Cleaning/Sanitizing

1. Turn off the water supply to the ice machine at the water service valve.

⚠ WARNING

Disconnect electric power to the ice machine at the electric switch box before proceeding.

2. Remove the parts or components you want to clean or sanitize. See the following pages for removal procedures for these parts.

⚠ WARNING

Wear rubber gloves and safety goggles (and/or face shield) when handling Ice Machine Cleaner or Sanitizer.

3. Soak the removed part(s) in a properly mixed solution.

Solution Type	Water	Mixed With
Cleaner	1 gal. (4 l)	16 oz (500 ml) cleaner
Sanitizer	4 gal. (15 l)	1 oz (30 ml) sanitizer

4. Use a soft-bristle brush or sponge (NOT a wire brush) to carefully clean the parts.

⚠ CAUTION

Do not mix Cleaner and Sanitizer solutions together. It is a violation of Federal law to use these solutions in a manner inconsistent with their labeling.

⚠ CAUTION

Do not immerse the water pump motor in the cleaning or sanitizing solution.

5. Use the solution and a brush to clean the top, sides, and bottom evaporator extrusions; the inside of the ice machine panels; and the entire inside of the bin.
6. Thoroughly rinse all of the parts and surfaces with clean water.
7. Install the removed parts.
8. Turn on the water and electrical supply.

Water Dump Valve

The water dump valve normally does not require removal for cleaning.

To determine if removal is necessary:

1. Locate the water dump valve.
2. Set the toggle switch to ICE.
3. While the ice machine is in the freeze mode, check the dump valve's clear plastic outlet drain hose for leakage.
 - A. If the dump valve is leaking, remove, disassemble and clean it.
 - B. If the dump valve is not leaking, do not remove it. Instead, follow the "Cleaning Procedure" on page 4-2.

Follow the procedure below to remove the dump valve.

Dump Valve Removal

⚠ WARNING

Disconnect the electric power to the ice machine at the electric service switch box and turn off the water supply before proceeding.

1. If so equipped, remove the water dump valve shield from its mounting bracket.
2. Lift and slide the coil retainer cap from the top of the coil.
3. Note the position of the coil assembly on the valve for assembly later. Leaving the wires attached, lift the coil assembly off the valve body and the enclosing tube.
4. Press down on the plastic nut on the enclosing tube and rotate it 1/4 turn. Remove the enclosing tube, plunger, and plastic gasket from the valve body.

NOTE: At this point, the water dump valve can easily be cleaned. If complete removal is desired, continue with step 5.

Important

The plunger and the inside of the enclosing tube must be completely dry before assembly.

NOTE: During cleaning, do not stretch, damage or remove the spring from the plunger. If it is removed, slide the spring's flared end into the plunger's slotted top opening until the spring contacts the plunger spring stop.

5. Remove the valve body.
6. Remove the tubing from the dump valve by twisting the clamps off.
7. Remove the two screws securing the dump valve and the mounting bracket.

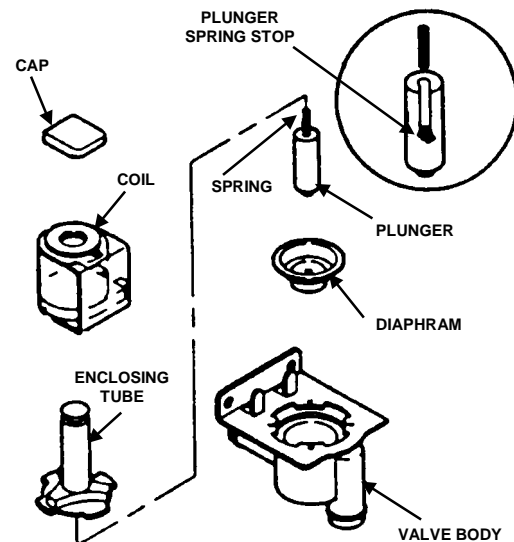

Dump Valve Disassembly

Water Pump

⚠ WARNING

Disconnect the electric power to the ice machine at the electric service switch box and turn off the water supply.

1. Disconnect the water pump power cord.

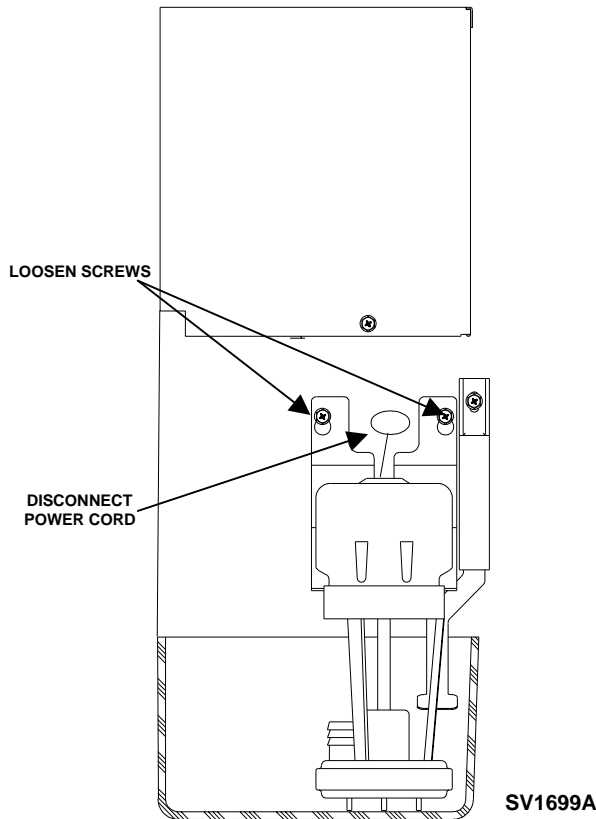

Water Pump Removal

2. Disconnect the hose from the pump outlet.
3. Loosen the screws securing the pump mounting bracket to the bulkhead.
4. Lift the pump and bracket assembly off the screws.

Ice Thickness Probe

1. Compress the side of the ice thickness probe near the top hinge pin and remove it from the bracket.

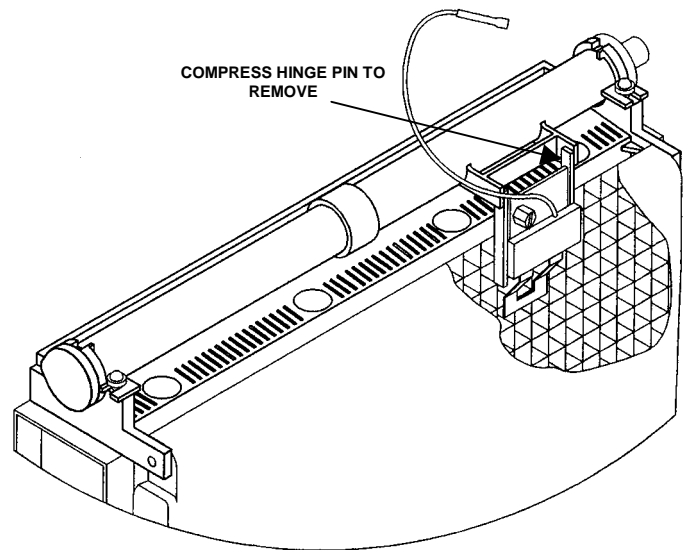

Ice Thickness Probe Removal

NOTE: At this point, the ice thickness probe can easily be cleaned. If complete removal is desired, continue with step 2 below.

⚠ WARNING

Disconnect the electric power to the ice machine at the electric service switch box.

2. Disconnect the wire lead from the control board inside the electrical control box.

Water Level Probe

1. Loosen the screw that holds the water level probe in place. The probe can easily be cleaned at this point without proceeding to step 2.

WARNING

Disconnect the electrical power to the ice machine at the electrical disconnect before proceeding.

2. If complete removal is required, disconnect the wire lead from the control board inside the electrical control box.

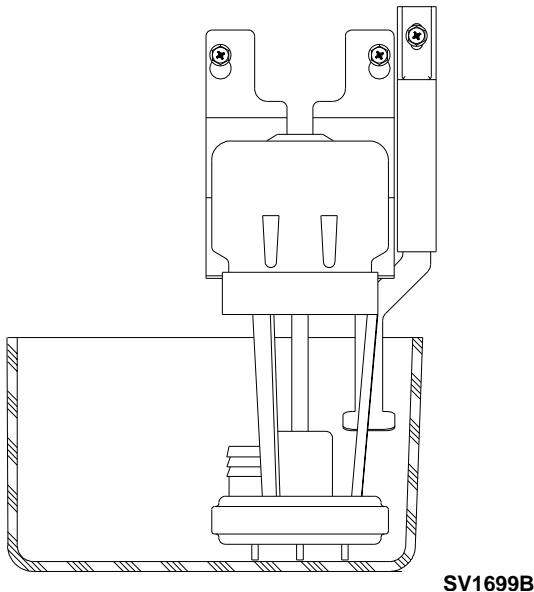

Water Level Probe Removal

Water Inlet Valve

The water inlet valve normally does not require removal for cleaning. Follow the instructions below to determine if removal is necessary.

1. Set the ICE/OFF/CLEAN switch to OFF. Locate the water inlet valve (in the water area of the ice machine). It pours water into the water trough.
2. When the ice machine is off, the water inlet valve must completely stop water flow into the machine. Watch for water flow. If water flows, remove, disassemble and clean the valve.
3. When the ice machine is on, the water inlet valve must allow the proper water flow through it. Set the toggle switch to ON. Watch for water flow into the ice machine. If the water flow is slow or only trickles into the ice machine remove disassemble, and clean the valve.

Follow the procedure below to remove the water inlet valve.

WARNING

Disconnect the electric power to the ice machine at the electric service switch box and turn off the water supply before proceeding.

1. Remove the valve shield if necessary.
2. Remove the filter access screws that hold the valve in place.

NOTE: The water inlet valve can be disassembled and cleaned without disconnecting the incoming water supply line to the ice machine.

3. Remove, clean, and install the filter screen.
4. If necessary, remove the enclosure tube access screws to clean interior components.

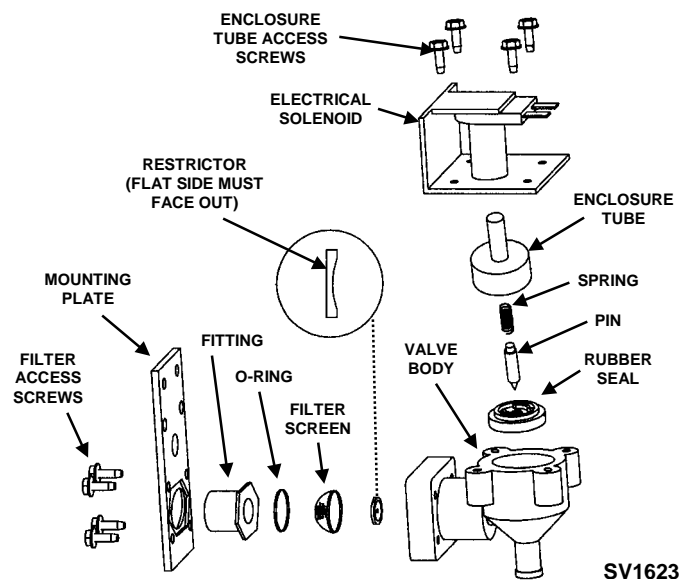

Exploded View of Water Inlet Valve

Water Distribution Tube

1. Disconnect the water hose from the distribution tube.

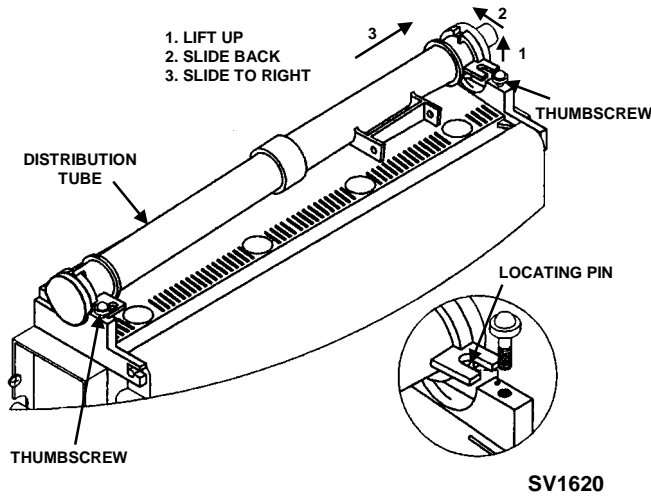

Water Distribution Tube Removal

2. Loosen the two thumbscrews which secure the distribution tube.
3. Lift the right side of the distribution tube up off the locating pin, then slide it back and to the right.

⚠ CAUTION

Do not force this removal. Be sure the locating pin is clear of the hole before sliding the distribution tube out.

4. Disassemble for cleaning.
 - A. Twist both of the inner tube ends until the tabs line up with the keyways.
 - B. Pull the inner tube ends outward.

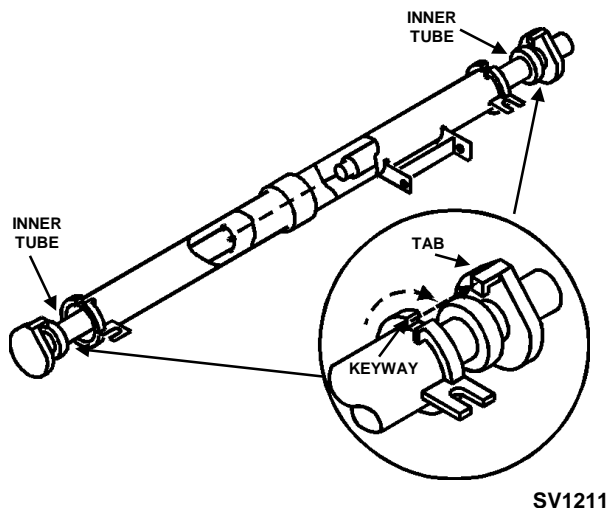

Water Distribution Tube Disassembly

Water Curtain

1. Gently flex the curtain in the center and remove it from the right side.

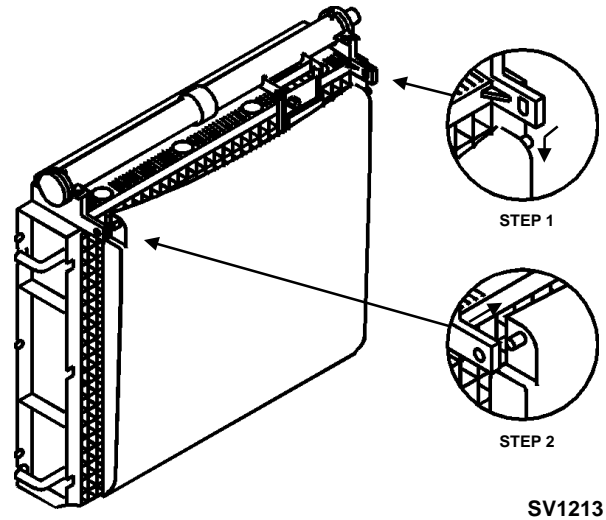

Water Curtain Removal

2. Slide the left pin out.

Water Treatment/Filtration

GENERAL

Local water conditions may require the installation of a water treatment system to inhibit scale formation, filter out sediment, and remove chlorine taste and odor. Consult your local distributor for information on Manitowoc's full line of NSF®-certified Tri-Liminator® filtration systems.

FILTER REPLACEMENT PROCEDURE

Tri-Liminator® systems include a pre-filter and a primary filter. For maximum filtration efficiency, replace the primary filter cartridge every six months. If the filter gauge reading drops below 20 psig prior to six months usage, replace the pre-filter first.

1. Turn off the water supply at the inlet shutoff valve.

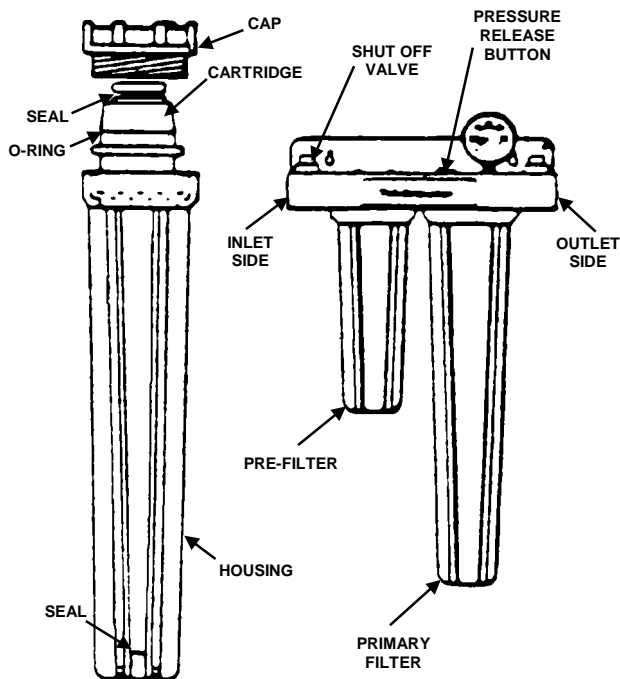

Typical Tri-Liminator® Water Filtration System

2. Depress the pressure release button to relieve the pressure.

3. Unscrew the housing from the cap.
4. Remove the used filter cartridge from the housing and discard it.
5. Remove the O-ring from the housing groove. Wipe the housing groove and the O-ring clean.
6. Lubricate the O-ring with petroleum jelly.
7. Press the O-ring into the housing groove.
8. Insert a new filter cartridge into the housing. Make sure it slips down over the housing standpipe.
9. Screw the housing on to the cap and carefully hand-tighten it.



CAUTION

Hand-tighten only. Do not overtighten. Do not use a spanner wrench.

10. Repeat steps 3-9 for each filter housing.
11. Turn on the water supply to allow the housing and filter to slowly fill with water.
12. Depress the pressure release button to release trapped air from the housing.
13. Check for leaks.

Removal from Service/Winterization

GENERAL

Special precautions must be taken if the ice machine is to be removed from service for an extended period of time or exposed to ambient temperatures of 32°F (0°C) or below.

AUCS® ACCESSORY

Refer to the AUCS® Accessory manual for winterization of the AUCS® Accessory.



CAUTION

If water is allowed to remain in the ice machine in freezing temperatures, severe damage to some components could result. Damage of this nature is not covered by the warranty.

Follow the applicable procedure below.

1. Move all Ice/Off/Clean toggle switches to the off position.
2. Turn off the water supply.
3. Remove the water from the water trough.
4. Disconnect and drain the incoming ice-making water line at the rear of the ice machine.
5. Move the Ice/Off/Clean toggle switch to Ice and blow compressed air in the drain opening until no more water comes out of the drain line.
6. Wait until the compressor starts then blow compressed air in the incoming water opening in the rear of the ice machine, until no more water comes out of the inlet water lines.
7. Make sure water is not trapped in any of the water lines, drain lines, distribution tubes, etc.
8. Disconnect the electric power at the circuit breaker or the electric service switch.
9. Refer to Copeland manual for winterization of condensing unit.

Section 5 Before Calling for Service

Checklist

If a problem arises during operation of your ice machine, follow the checklist below before calling for service. Routine adjustments and maintenance procedures are not covered by the warranty.

Problem	Possible Cause	To Correct
Ice machine does not operate.	No electrical power to the ice machine or condensing unit.	Replace the fuse/reset the breaker/turn on the main switch.
	ICE/OFF/CLEAN toggle switch set improperly.	Move the toggle switch to the ICE position.
	Water curtain stuck open.	Curtain must be capable of swinging freely. See page 4-8.
	Safety limit feature stopping the ice machine.	Refer to "Safety Limit Feature" on the next page.
Ice machine stops, and can be restarted by moving the toggle switch to OFF and back to ICE.	Safety limit feature stopping the ice machine.	Refer to "Safety Limit Feature" on the next page.
Ice machine does not release ice or is slow to harvest.	Ice machine is dirty.	Clean and sanitize the ice machine. See pages 4-2 and 4-3.
	Ice machine is not level.	Level the ice machine. See page 2-2.
Ice machine does not cycle into harvest mode.	The six-minute freeze time lock-in has not expired yet.	Wait for freeze lock-in to expire.
	Ice thickness probe is dirty.	Clean and sanitize the ice machine. See pages 4-2 and 4-3.
	Ice thickness probe wire is disconnected.	Connect the wire.
	Ice thickness probe is out of adjustment.	Adjust the ice thickness probe. See page 3-4.
	Uneven ice fill (thin at top of evaporator).	See "Shallow or Incomplete Cubes" on the next page.
Ice quality is poor (soft or not clear).	Poor incoming water quality.	Contact a qualified service company to test the quality of the incoming water and make appropriate filter recommendations.
	Water filtration is poor.	Replace the filter.
	Ice machine is dirty.	Clean and sanitize the ice machine. See pages 4-2 and 4-3.
	Water dump valve is not working.	Disassemble and clean the water dump valve. See page 4-5.
	Water softener is working improperly (if applicable).	Repair the water softener.

Continued on next page...

Problem	Possible Cause	To Correct
Ice machine produces shallow or incomplete cubes, or the ice fill pattern on the evaporator is incomplete.	Ice thickness probe is out of adjustment.	Adjust the ice thickness probe. See page 3-4.
	Water trough level is too high or too low.	Check the water level. See page 3-4.
	Water inlet valve filter screen is dirty.	Remove and clean the filter screen. See page 4-7.
	Water filtration is poor.	Replace the filter.
	Hot incoming water.	Connect the ice machine to a cold water supply. See page 2-8.
	Water inlet valve is not working.	Remove the water inlet valve and clean it. See page 4-7.
	Incorrect incoming water pressure.	Water pressure must be 20-80 psi (137.9 - 551.5 kPA).
	Water dump valve leaking	Clean the dump valve See page 4-5
Low ice capacity.	Ice machine is not level.	Level the ice machine. See page 2-2.
	Water inlet valve filter screen is dirty.	Remove and clean the filter screen. See page 4-7.
	Incoming water supply is shut off.	Open the water service valve.
	Water inlet valve stuck open or leaking.	Remove the water inlet valve and clean it. See page 4-7.
	The condenser is dirty.	Clean the condenser.
Water dump valve leaking	Clean the dump valve See page 4-5	

Safety Limit Feature

In addition to the standard safety controls, your Manitowoc ice machine features built-in safety limits, which will stop the ice machine if conditions arise which, could cause a major component failure.

Safety Limit Stand-By Mode:

The first time a safety limit shut down occurs, the ice machine turns off for 60 minutes (Stand-by Mode). The ice machine will then automatically restart to see if the problem re-occurs. During the Stand-By Mode the harvest light will be flashing. If the same safety limit is reached a second time (the problem has re-occurred) the ice machine will initiate a safety limit shut down and remain off until it is manually restarted. During a safety limit shut down the harvest light will be flashing.

Before calling for service, re-start the ice machine using the following procedure:

1. Move the ICE/OFF/CLEAN switch to OFF and then back to ICE.
 - A. If the safety limit feature has stopped the ice machine, it will restart after a short delay. Proceed to step 2.
 - B. If the ice machine does not restart, see “Ice machine does not operate” on the previous page.
2. Allow the ice machine to run to determine if the condition is reoccurring.
 - A. If the ice machine stops again, the condition has recurred. Call for service.
 - B. If the ice machine continues to run, the condition has corrected itself. Allow the ice machine to continue running.

Section 6 Electrical System

P MODEL POINT OF USE

Ice Making Sequence of operation Chart

SEQUENCE of OPERATION	Control Board Relays					Contactor 3A EVAPORATOR HEATERS	LENGTH of TIME
	1 WATER PUMP	2 WATER FILL VALVE	3 CONTACTOR COIL	4 WATER DUMP VALVE	5 SUCTION LINE SOLENOID		
INITIAL START-UP/ START UP AFTER AUTO SHUT-OFF: 1. Water Purge	on	off	off	on	off	off	45 <i>Seconds</i>
FREEZE SEQUENCE: 2. Prechill 3. Freeze	off	<div style="text-align: center;"> ↑ May cycle on/off for first 45 seconds ↓ Cycle on then off 1 more time </div>	off	off	on	off	30 <i>Seconds</i>
	on		off	off	on	off	<i>Until 10 second water contact with ice thickness probe</i>
HARVEST SEQUENCE: 4. Water Purge 5. Harvest	on	30 sec. off ----- 15 sec. on	on	on	off	on	<i>Water purge factory set at 45 Seconds</i>
	off	off	on	off	off	on	<i>Bin switch activation</i>
6. AUTO SHUT-OFF	off	off	off	off	off	off	<i>Until bin switch re-closes</i>

Control Board Safety Timers

Freeze Sequence:

- The ice machine is locked in the freeze sequence for the first 6 minutes, not allowing the ice thickness probe to initiate a harvest sequence.
- The maximum freeze time is 60 minutes, at which time the control board automatically initiates a harvest sequence (steps 4-5).
- The maximum "on time" for the water fill valve is 6 minutes, at which time it automatically turns off.

Harvest Sequence:

- The maximum "on time" for evaporator heaters is 5.5 minutes, at which time the contactor will automatically de-energize to shut the heaters off.
- The maximum harvest time is 6-1/2 minutes, at which time the control board automatically terminates the harvest sequence. If the bin switch is open, the ice machine will go to Automatic shut-off (step 6). If the bin switch is closed, the ice machine will go to the freeze sequence (steps 2-3).

Component Specifications and Diagnostics

MAIN FUSE

Function

The control board fuse stops ice machine operation if electrical components fail causing high amp draw.

Specifications

The main fuse is 250 Volt, 7 amp.

Check Procedure



WARNING

High (line) voltage is applied to the control board (terminals #55 and #56) at all times. Removing the control board fuse or moving the toggle switch to OFF will not remove the power supplied to the control board.

1. If the bin switch light is on with the water curtain closed, the fuse is good.



WARNING

Disconnect electrical power to the entire ice machine before proceeding.

2. Remove the fuse. Check the resistance across the fuse with an ohmmeter.

Reading	Result
Open (OL)	Replace fuse
Closed (O)	Fuse is good

BIN SWITCH

Function

Bin switch operation is controlled by movement of the water curtain. The bin switch has two main functions:

1. Terminating the harvest cycle and returning the ice machine to the freeze cycle.

This occurs when the bin switch is opened and closed again within 7 seconds during the harvest cycle.

2. Automatic ice machine shut-off.

If the storage bin is full at the end of a harvest cycle, the sheet of cubes fails to clear the water curtain and holds it open. After the water curtain is held open for 7 seconds, the ice machine shuts off.

The ice machine remains off until enough ice is removed from the storage bin to allow the sheet of cubes to drop clear of the water curtain. As the water curtain swings back to the operating position, the bin switch closes and the ice machine restarts.

Important

The water curtain must be ON (bin switch closed) to start ice making.

Specifications

The bin switch is a magnetically operated reed switch. The magnet is attached to the lower right corner of the water curtain. The switch is attached to the evaporator mounting bracket.

The bin switch is connected to a varying D.C. voltage circuit. (Voltage does not remain constant.)

NOTE: Because of a wide variation in D.C. voltage, it is not recommended that a voltmeter be used to check bin switch operation.

Continued on next page

Bin Switch Check Procedure

1. Set the toggle switch to OFF.
2. Watch the bin switch light on the control board.
3. Move the water curtain toward the evaporator. The bin switch must close. The bin switch light "on" indicates the bin switch has closed properly.
4. Move the water curtain away from the evaporator. The bin switch must open. The bin switch light "off" indicates the bin switch has opened properly.

Ohm Test

1. Disconnect the bin switch wires to isolate the bin switch from the control board.
2. Connect an ohmmeter to the disconnected bin switch wires. Set the ohmmeter to the 10,000-ohm scale.
3. Cycle the bin switch by opening and closing the water curtain.
4. With the bin switch open: Resistance readings of more than 30,000 ohms indicate a correctly operating bin switch.
5. With the bin switch closed: Resistance readings of less than 70 ohms indicates a correctly operating bin switch.

Important

Any reading between 70 and 30,000 ohms, regardless of curtain position, indicates a defective bin switch

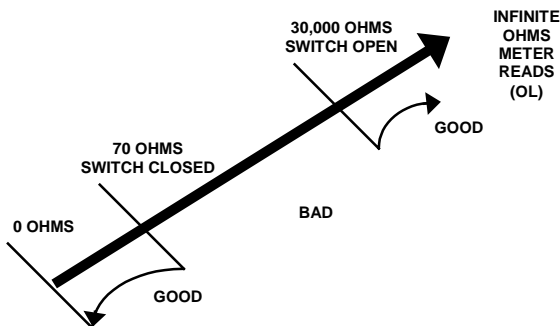
**Bin Switch Resistance Readings****Water Curtain Removal Notes**

The water curtain must be on (bin switch closed) to start ice making. While a freeze cycle is in progress, the water curtain can be removed and installed at any time without interfering with the electrical control sequence.

If the ice machine goes into harvest sequence while the water curtain is removed, one of the following will happen:

- Water curtain remains off:
When the harvest cycle time reaches 3.5 minutes and the bin switch is not closed, the ice machine stops as though the bin were full.
- Water curtain is put back on:
If the bin switch closes prior to reaching the 3.5 minute point, the ice machine immediately returns to another freeze sequence prechill.

ICE/OFF/CLEAN TOGGLE SWITCH

Function

This switch is used to place the ice machine in ICE, OFF or CLEAN mode of operation.

Specifications

Double-pole, double-throw switch. The switch is connected into a varying low D.C. voltage circuit.

Check Procedure

NOTE: Because of a wide variation in D.C. voltage, it is not recommended that a voltmeter be used to check toggle switch operation.

1. Inspect the toggle switch for correct wiring.
2. Isolate the toggle switch by disconnecting all wires from the switch, or by disconnecting the Molex connector and removing wire #69 from the toggle switch.
3. Check across the toggle switch terminals using a calibrated ohmmeter. Note where the wire numbers are connected to the switch terminals, or refer to the wiring diagram to take proper readings.

Switch Setting	Terminals	Ohm Reading
ICE	66-62	Open
	67-68	Closed
	67-69	Open
CLEAN	66-62	Closed
	67-68	Open
	67-69	Closed
OFF	66-62	Open
	67-68	Open
	67-69	Open

4. Replace the toggle switch if ohm readings do not match all three-switch settings.

HARVEST HEATER ELEMENT

Function

Warms the evaporator in the harvest cycle, allowing the ice to release.

Specifications

Model	Volt	Amp	Ohm
Upper	115	9.4 to 11.5	10.4 to 12.1
Lower	115	5.1 to 6.2	19.3 to 22.5

*Listed ohm values are at room temperature.

Check Procedure

1. Cycle the ice machine into a harvest sequence.
2. Attach an amp probe to one lead of the harvest heater element and read amp draw. See Specifications (above) for amp/ohm values.

Results of Check	Action
Amperage and ohm value within specifications	Element is OK
No Amperage or continuity	See Harvest Heater Thermostat on next page.
Amperage and/or Ohm value not within specifications	Replace the element

Replacement Procedure.

1. Remove evaporator assembly from ice machine (see page 6-7).
2. Remove clips securing heater element to evaporator tubing.
3. Align replacement heater element with evaporator tubing.
4. Secure element to evaporator tubing with clips.
5. Re-install evaporator assembly.

HARVEST HEATER ELEMENT THERMOSTAT

Function

Safety control which de-energizes the harvest heater contactor coil, when the evaporator temperature exceeds the control setpoint.

The harvest heater thermostat is normally closed and opens on an increase in temperature.

Specifications

Automatic reset

Cut-in 110°F (+/- 5°F) (thermostat closed).

Cut-out 125°F (+/- 5°F) (thermostat open).

Check Procedure

1. Insert a temperature probe next to the harvest heater thermostat sensor.
2. Hook a voltmeter in parallel (across) the harvest heater thermostat control, leaving wires attached

IMPORTANT:

This test must be completed within 5 1/2 minutes of starting the harvest sequence.

3. Cycle the ice machine into a harvest cycle by placing a jumper wire from the ice thickness probe to ground (see page 6-13).
4. Temperature below listed specification:

Meter will read 0 volts and the heater contactor coil will be energized.

Temperature above listed specification:

Meter will read line voltage and the heater contactor coil will be de-energized.

Replace the control if:

1. The control does not open at the specified setpoint.
2. The control will not reset

LOW PRESSURE CUT-OUT CONTROL

Function

Energizes and de-energizes the compressor contactor coil.

The LPC opens when the suction pressure reaches the cut-out setpoint, and closes when the suction pressures reach's the cut-in setpoint.

Specifications

Adjustable cut-in and cut-out

Factory Setting Cut-in 25 psig Cut-out 3 psig (These are minimum setpoints. The cut-in can be increased when low ambient temperatures will not be experienced.)

Check Procedure

NOTE: The suction pressure must exceed the cut-in setpoint to close the switch. The switch will then remain closed until the suction pressure drops below the cut-out setpoint.

1. Attach an accurate gauge to the suction service port on the condensing unit.
2. Hook a voltmeter in parallel across the low-pressure control, leaving wires attached.
3. Front seat (close) the suction service valve on the condensing unit. The suction pressure will decrease causing the low-pressure control to open at the listed specification. The voltage reading across the low-pressure cut-out control must be "line voltage".
4. Back seat (open) the suction service valve on the condensing unit. The suction pressure will increase causing the low-pressure control to close at the listed specification. The voltage reading across the low pressure cut-out control must be "0 volts".
5. Replace the low pressure cut-out control when it does not open and close properly or does not maintain proper settings.

CAUTION

Never set the Low Pressure Control to allow the refrigeration system to enter a vacuum.

SUCTION SOLENOID VALVE**FUNCTION**

Allows refrigerant flow through the evaporator during the freeze cycle, and prevents refrigerant flow through the evaporator in the harvest and auto shut-off cycles.

SPECIFICATIONS

Coil 115 volt 50/60 cycle.

CHECK PROCEDURE

1. Move the Ice/Off/Clean toggle switch to the Ice position.
2. Attach voltmeter at the suction solenoid valve coil, leaving wires attached. The meter reading must be line voltage and the suction solenoid valve must be open.
3. Move the Ice/Off/Clean toggle switch to the off position.
4. The meter reading must be 0 volts and the suction solenoid valve must be closed.

LINE SET ISOLATION VALVES**FUNCTION**

Isolates ice machine evaporator from refrigeration system.

Allows discharge and suction pressure readings to be taken at the schraeder valve fitting.

SPECIFICATIONS

Liquid Line 1/4" inlet
1/4" outlet
Suction Line 1/2" inlet
1/2" outlet

CHECK PROCEDURE

Remove 3/4" cap to access valve.

To backseat valve (open):

Turn full counterclockwise.

To frontseat valve (closed):

Turn full clockwise.

Replace 3/4" cap assuring a tight seal to eliminate possibility of refrigerant leakage.

EVAPORATOR REMOVAL**P-530**

1. Disconnect power to the ice machine at the service disconnect or breaker.
2. Remove front, back, side and top panels.
3. Disconnect wiring to the harvest heaters and suction solenoid coil.
4. Remove bin switch from evaporator extrusion.
5. Frontseat (close) the isolation valves on the liquid and suction line sets (see page 6-7).
6. Recover refrigerant from ice machine by accessing schraeder valves on the aeroquip fittings or line set isolation valves.
7. Disconnect line sets by unscrewing aeroquip fittings. Follow procedure on page 2-9 when reassembling.
8. Disconnect tubing and ice thickness probe from water distribution tube.
9. Disconnect and remove the water distribution tube.
10. Remove top angle bracket.
11. Remove the refrigeration cover plate (located in the left-hand side of the evaporator compartment) by removing two screws and sliding forward..
12. Remove the two screws securing the Aeroquip fitting assembly to the rear bulkhead.
13. Support the evaporator and remove the screws securing the evaporator to the bulkhead.
14. Lift the evaporator assembly out through the front of the ice machine

P-520

1. Disconnect power to the ice machine at the service disconnect or breaker.
2. Remove front, back, side and top panels.
3. Disconnect wiring to the harvest heaters and suction solenoid coil.
4. Remove bin switch from evaporator extrusion.
5. Frontseat (close) the isolation valves on the liquid and suction line sets (see page 6-7).
6. Recover refrigerant from ice machine by accessing schraeder valves on the aeroquip fittings or line set isolation valves.
7. Disconnect line sets by unscrewing aeroquip fittings. Follow procedure on page 2-9 when reassembling.
8. Disconnect ice thickness probe from water distribution tube.
9. Remove water pump and water distribution tube assembly.
10. Remove water level probe.
11. Remove water trough.
12. Remove cover plate located in the upper left-hand side of the evaporator compartment by removing the screw.
13. Remove the four screws securing the line drier/TXV assembly plate.
14. Remove screws attaching water inlet/dump valve control box (complete removal is not necessary).
15. Support the evaporator and remove the screws securing the evaporator to the bulkhead.
16. Lift the evaporator assembly out through the front of the ice machine

ELECTRONIC CONTROL BOARD

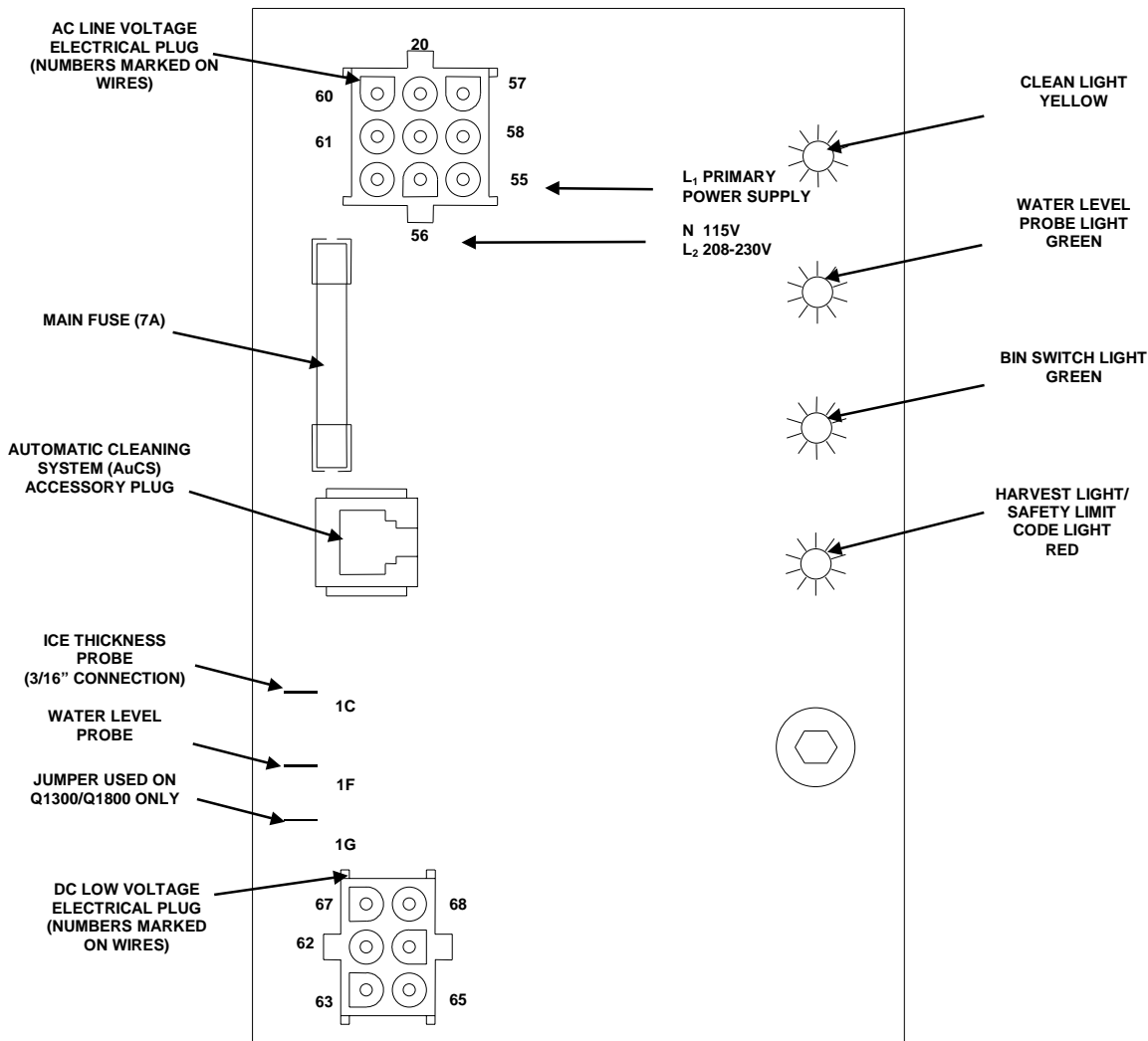

Control Board

SV1588

General

P-Model control boards use a dual voltage transformer. This means only one control board is needed for both 115V and 208-230V use.

The control board along with inputs controls all electrical components, including the ice machine sequence of operation. Prior to diagnosing, you must understand how the inputs affect the control board operation.

Refer to specific component specifications (inputs), wiring diagrams and ice machine sequence of operation sections for details.

As an example, refer to “Ice Thickness Probe” in the service section of this manual for information relating to how the probe and control board functions together.

This section will include items such as:

- How a harvest cycle is initiated
- How the harvest light functions with the probe
- Freeze time lock-in feature
- Maximum freeze time
- Diagnosing ice thickness control circuitry

SAFETY LIMITS

General

In addition to standard safety controls, such as high pressure cut-out, the control board has two built in safety limit controls which protect the ice machine from major component failures.

Safety Limit #1: If the freeze time reaches 60 minutes, the control board automatically initiates a harvest cycle. If three consecutive 60-minute freeze cycles occur, the ice machine stops.

Safety Limit #2: If the harvest time reaches 3.5 minutes, the control board automatically returns the ice machine to the freeze cycle. If three consecutive 3.5 minute harvest cycles occur, the ice machine stops.

Determining Which Safety Limit Stopped The Ice Machine

When a safety limit condition causes the ice machine to stop, the harvest light on the control board continually flashes on and off. Use the following procedures to determine which safety limit has stopped the ice machine.

1. Move the toggle switch to OFF.
2. Move the toggle switch back to ICE.
3. Watch the harvest light. It will flash one or two times, corresponding to safety limits 1 and 2, to indicate which safety limit stopped the ice machine.

After safety limit indication, the ice machine will restart and run until a safety limit is exceeded again.

Analyzing Why Safety Limits May Stop the Ice Machine

According to the refrigeration industry, a high percentage of compressors fail as a result of external causes. These can include: flooding or starving expansion valves, dirty condensers, water loss to the ice machine, etc. The safety limits protect the ice machine (primarily the compressor) from external failures by stopping ice machine operation before major component damage occurs.

The safety limit system is similar to a high pressure cut-out control. It stops the ice machine, but does not tell what is wrong. A service technician must analyze the system to determine what caused the high pressure cut-out, or a particular safety limit, to stop the ice machine.

The safety limits are designed to stop the ice machine prior to major component failures, most often a minor problem or something external to the ice machine. This may be difficult to diagnose, as many external problems occur intermittently.

Example: An ice machine stops intermittently on safety limit #1 (long freeze times). The problem could be a low ambient temperature at night, a water pressure drop, the water is turned off one night a week, etc.

When a high pressure cut-out or a safety limit stops the ice machine, they are doing what they are supposed to do. That is, stopping the ice machine before a major component failure occurs.

Refrigeration and electrical component failures may also trip a safety limit. Eliminate all electrical components and external causes first. If it appears that the refrigeration system is causing the problem, use Manitowoc's Refrigeration System Operational Analysis Table, along with detailed charts, checklists, and other references to determine the cause.

The following checklists are designed to assist the service technician in analysis. However, because there are many possible external problems, do not limit your diagnosis to only the items listed.

Safety Limit #1

Freeze time exceeds 60 minutes for 3 consecutive freeze cycles.

Possible Cause	Check/Correct
Improper installation	<ul style="list-style-type: none"> • See section 2 "Installation Instructions"
Water system	<ul style="list-style-type: none"> • Low water pressure (20 psi min.) • High water pressure (80 psi max.) • High water temperature (90°F/32.2°C max.) • Clogged water distribution tube • Dirty/defective water fill valve • Dirty/defective water dump valve • Defective water pump
Electrical system	<ul style="list-style-type: none"> • Ice thickness probe out of adjustment • Harvest cycle not initiated electrically • Harvest heater contactor not energizing • Compressor electrically non-operational
Restricted condenser air flow	<ul style="list-style-type: none"> • High inlet air temperature (110°F/43.3°C max.) • Dirty condenser fins • Defective fan motor
Refrigeration system	<ul style="list-style-type: none"> • Non-Manitowoc components • Improper refrigerant charge • Defective head pressure control • Defective compressor • TXV starving or flooding (check bulb mounting) • Non-condensibles in refrigeration system • Plugged or restricted high side refrigerant lines or component

Safety Limit #2

Harvest time exceeds 6.5 minutes for 3 consecutive harvest cycles.

Possible Cause	Check/Correct
Improper installation	<ul style="list-style-type: none"> • See section 2 "Installation Instructions"
Water system	<ul style="list-style-type: none"> • Water area (evaporator) dirty • Dirty/defective water dump valve • Water freezing behind evaporator • Plastic extrusions and gaskets not securely mounted to the evaporator • Low water pressure (20 psi min.) • Loss of water from sump area • Clogged water distribution tube • Dirty/defective water fill valve • Defective water pump
Electrical system	<ul style="list-style-type: none"> • Ice thickness probe out of adjustment • Ice thickness probe dirty • Bin switch defective • Premature harvest • Defective harvest heater element
Refrigeration system	<ul style="list-style-type: none"> • Non-Manitowoc components • Improper refrigerant charge • Defective head pressure control valve • TXV flooding (check bulb mounting)

Safety Limit Notes

- Because there are many possible external problems, do not limit your diagnosis to only the items listed in this chart.
- A continuous run of 100 harvests automatically erases the safety limit code.
- The control board will store and indicate only one safety limit – the last one exceeded
- If the toggle switch is moved to the off position and then back to the ICE position prior to reaching the 100-harvest point, the last safety limit exceeded will be indicated.
- If the harvest light did not flash prior to the ice machine restarting, then the ice machine did not stop because it exceeded a safety limit.

Safety Limit Stand-By Mode:

The first time a safety limit shut down occurs, the ice machine turns off for 60 minutes (Stand-by Mode). The ice machine will then automatically restart to see if the problem re-occurs. During the Stand-By Mode the harvest light will be flashing. If the same safety limit is reached a second time (the problem has re-occurred) the ice machine will initiate a safety limit shut down and remain off until it is manually restarted. During a safety limit shut down the harvest light will be flashing.

Re-start the ice machine using the following procedure:

1. Move the ICE/OFF/CLEAN switch to OFF and then back to ICE.
 - A. If the safety limit feature has stopped the ice machine, it will restart after a short delay. Proceed to step 2.
 - B. If the ice machine does not restart, see “Ice machine does not operate” Section 5.
2. Allow the ice machine to run to determine if the condition is reoccurring.

If the ice machine stops again, the condition has reoccurred, and the cause must be determined.

If the ice machine continues to run, the condition has corrected itself. Allow the ice machine to continue running.

Ice Thickness Probe (Harvest Initiation)

HOW THE PROBE WORKS

Manitowoc's electronic sensing circuit does not rely on refrigerant pressure, evaporator temperature, water levels or timers to produce consistent ice formation.

As ice forms on the evaporator, water (not ice) contacts the ice thickness probe. After the water completes this circuit across the probe continuously for 6-10 seconds, a harvest cycle is initiated.

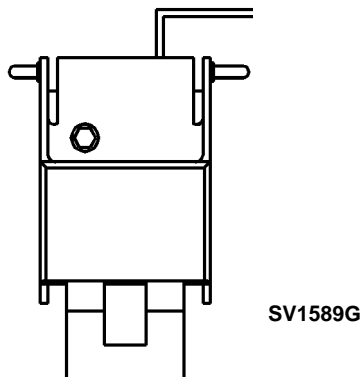

Ice Thickness Probe

HARVEST/SAFETY LIMIT LIGHT

This light's primary function is to be on as water contacts the ice thickness probe during the freeze cycle, and remain on throughout the entire harvest cycle. The light will flicker as water splashes on the probes.

The light's secondary function is to continuously flash when the ice machine is shut off on a safety limit, and to indicate which safety limit shut off the ice machine.

FREEZE TIME LOCK-IN FEATURE

The ice machine control system incorporates a freeze time lock-in feature. This prevents the ice machine from short cycling in and out of harvest.

The control board locks the ice machine in the freeze cycle for six minutes. If water contacts the ice thickness probe during these six minutes, the harvest light will come on (to indicate that water is in contact with the probe), but the ice machine will stay in the freeze cycle. After the six minutes are up, a harvest cycle is initiated. This is important to remember when performing diagnostic procedures on the ice thickness control circuitry.

To allow the service technician to initiate a harvest cycle without delay, this feature is not used on the first cycle after moving the toggle switch OFF and back to ICE.

MAXIMUM FREEZE TIME

The control system includes a built-in safety that will automatically cycle the ice machine into harvest after 60 minutes in the freeze cycle.

ICE THICKNESS CHECK

The ice thickness probe is factory-set to maintain the ice bridge thickness at 1/8" (3.2 mm).

NOTE: Make sure the water curtain is in place when performing this check. It prevents water from splashing out of the water trough.

1. Inspect the bridge connecting the cubes. It should be about 1/8" (3.2 mm) thick.
2. If adjustment is necessary, turn the ice thickness probe adjustment screw clockwise to increase bridge thickness, or counterclockwise to decrease bridge thickness.

NOTE: Turning the adjustment 1/3 of a turn will change the ice thickness about 1/16" (1.5 mm).

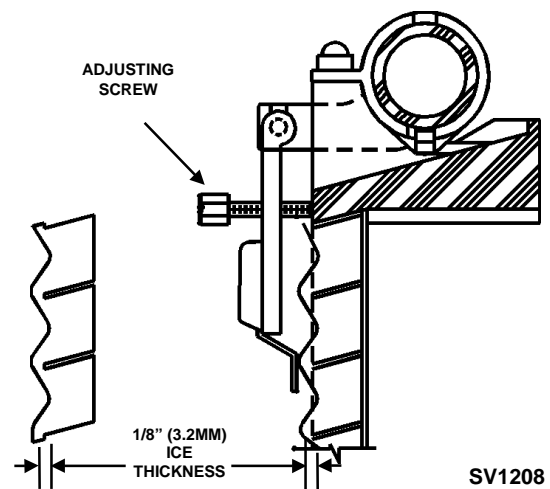

Ice Thickness Check

Make sure the ice thickness probe wire and the bracket do not restrict movement of the probe.

DIAGNOSING ICE THICKNESS CONTROL CIRCUITRY

Ice Machine Does Not Cycle Into Harvest When Water Contacts The Ice Thickness Control Probe

Step 1 Bypass the freeze time lock-in feature by moving the ICE/OFF/CLEAN switch to OFF and back to ICE. Wait until the water starts to flow over the evaporator.

Step 2 Clip the jumper wire leads to the ice thickness probe and any cabinet ground.

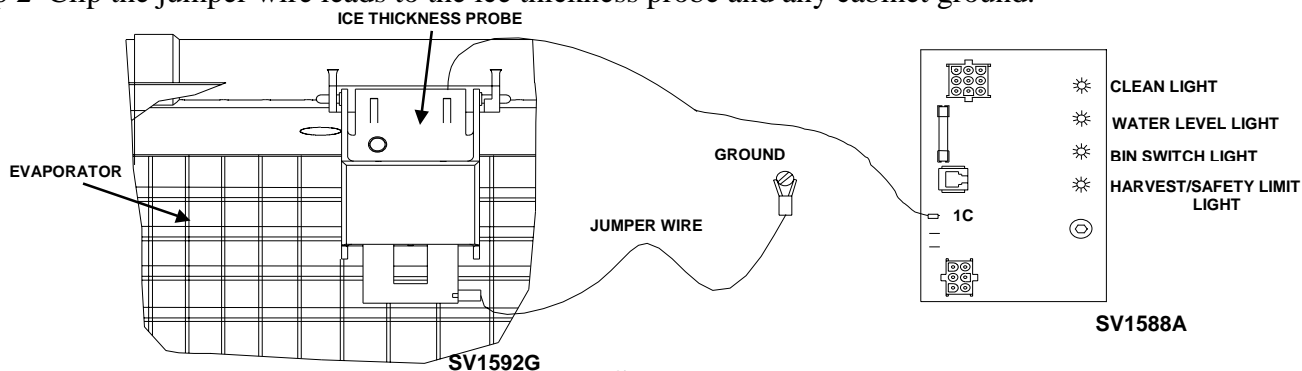

Step 2

Step 2 Jumper wire connected from probe to ground	
Monitoring of Harvest Light	Correction
The harvest light comes on, and 6-10 seconds later, ice machine cycles from freeze to harvest.	The ice thickness control circuitry is functioning properly. Do not change any parts.
The harvest light comes on but the ice machine stays in the freeze sequence.	The ice thickness control circuitry is functioning properly. The ice machine is in a six-minute freeze time lock-in. Verify step 1 of this procedure was followed correctly.
The harvest light does not come on.	Proceed to Step 3, below.

Step 3 Disconnect the ice thickness probe from the control board at terminal 1C. Clip the jumper wire leads to terminal 1C on the control board and any cabinet ground. Monitor the harvest light.

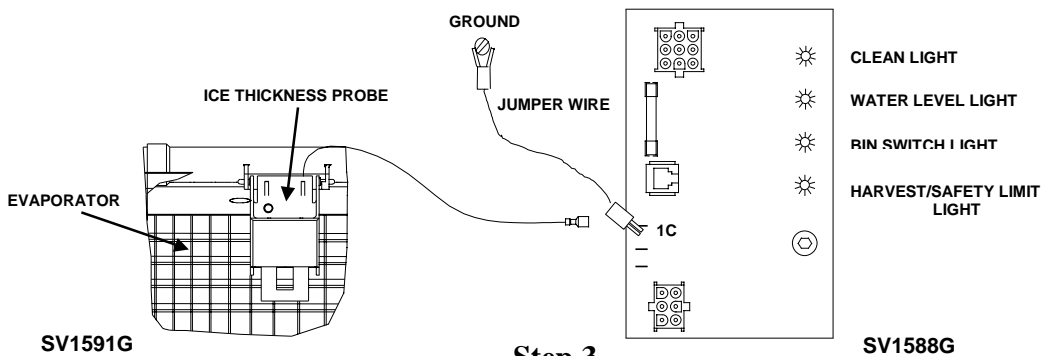

Step 3

Step 3 Jumper wire connected from control board terminal 1C to ground	
Monitoring of Harvest Light	Correction
The harvest light comes on, and 6-10 seconds later, ice machine cycles from freeze to harvest.	The ice thickness probe is causing the malfunction.
The harvest light comes on but the ice machine stays in the freeze sequence.	The control circuitry is functioning properly. The ice machine is in a six-minute freeze time lock-in (verify step 1 of this procedure was followed correctly).
The harvest light does not come on.	The control board is causing the malfunction.

Ice Machine Cycles Into Harvest Before Water Contact With The Ice Thickness Probe

Step 1 Disconnect the ice thickness probe from the control board at terminal 1C.

Step 2 Bypass the freeze time lock-in feature by moving the ICE/OFF/CLEAN switch to OFF and back to ICE. Wait until the water starts to flow over the evaporator, then monitor the harvest light.

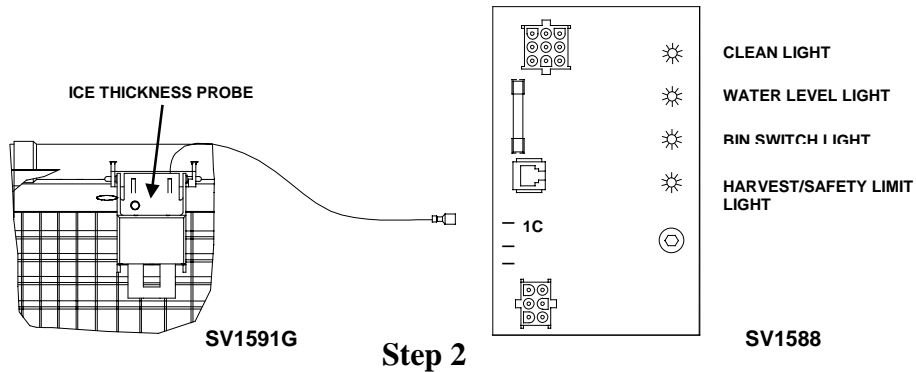

Step 2 Disconnect probe from control board terminal 1C	
Monitoring of Harvest Light	Correction
The harvest light stays off and the ice machine remains in the freeze sequence.	The ice thickness probe is causing the malfunction. Verify that the Ice Thickness probe is adjusted correctly.
The harvest light comes on, and 6-10 seconds later, the ice machine cycles from freeze to harvest.	The control board is causing the malfunction.

Water Level Control Circuitry

WATER LEVEL PROBE LIGHT

The water level probe circuit can be monitored by watching the water level light. The water level light is on when water contacts the probe, and off when no water is in contact with the probe. The water level light functions any time power is applied to the ice machine, regardless of toggle switch position.

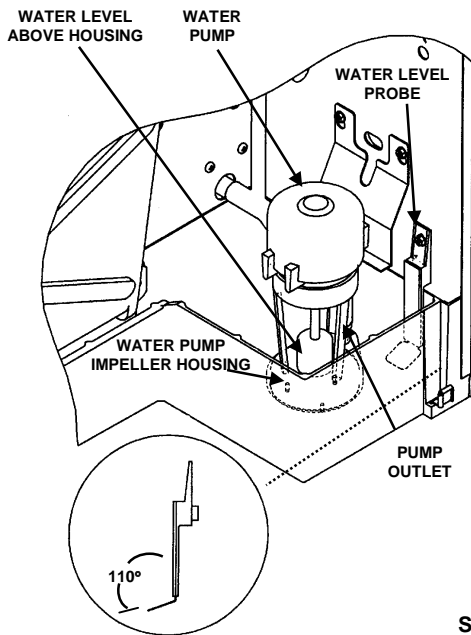

SV1616

FREEZE CYCLE WATER LEVEL SETTING

During the freeze cycle, the water level probe is set to maintain the proper water level above the water pump housing. The water level is not adjustable. If the water level is incorrect, check the water level probe for damage (probe bent, etc.). Repair or replace the probe as necessary.

WATER INLET VALVE SAFETY SHUT-OFF

The water inlet valve will energize only during the first six minutes of the freeze cycle. In the event of a water level probe failure, this feature limits the water inlet valve to a six-minute on time. Regardless of the water level probe input, the control board automatically shuts off the water inlet valve if it remains on for 6 continuous minutes. This is important to remember when performing diagnostic procedures on the water level control circuitry.

FREEZE CYCLE CIRCUITRY

Manitowoc’s electronic sensing circuit does not rely on float switches or timers to maintain consistent water level control. During the freeze cycle, the water inlet valve energizes (turns on) and de-energizes (turns off) in conjunction with the water level probe located in the water trough.

During the first 45 seconds of the Freeze Cycle:

The water inlet valve is **on** when there is no water in contact with the water level probe. The water inlet valve turns **off** after water contacts the water level probe for 3 continuous seconds. The water inlet valve will cycle on and off as many times as needed to fill the water trough.

After 45 seconds into the Freeze Cycle:

The water inlet valve will cycle on, and then off one more time to refill the water trough. The water inlet valve is now off for the duration of the freeze sequence.

HARVEST CYCLE CIRCUITRY

The water level probe does not control the water inlet valve during the harvest cycle. During the harvest cycle water purge, the water inlet valve energizes (turns on) and de-energizes (turns off) strictly by time. The harvest water purge adjustment dial may be set at 15, 30 or 45 seconds.

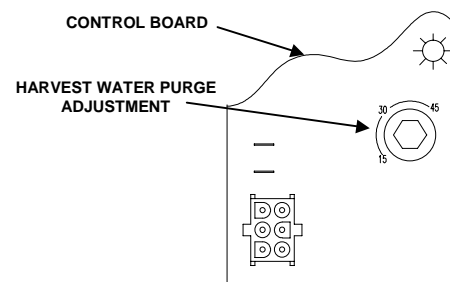

SV1617

NOTE: The water purge **must be at the factory setting** of 45 seconds for the water inlet valve to energize during the last 15 seconds of the Water Purge. If set at 15 or 30 seconds the water inlet valve will not energize during the harvest water purge

DIAGNOSING FREEZE CYCLE POTABLE WATER LEVEL CONTROL CIRCUITRY

Problem: Water Trough Overfilling During The Freeze Cycle

Step 1 Start a new freeze sequence by moving the ICE/OFF/CLEAN toggle switch to OFF, then back to ICE.

Important

This restart must be done prior to performing diagnostic procedures. This assures the ice machine is not in a freeze cycle water inlet valve safety shut-off mode. You must complete the entire diagnostic procedure with-in 6 minutes of starting.

Step 2 **Wait until the freeze cycle starts** (approximately 45 seconds, the freeze cycle starts when the water pump energizes) then connect a jumper from the water level probe to any cabinet ground.

Important

For the test to work properly you must wait until the freeze cycle starts, prior to connecting the jumper wire. If you restart the test you must disconnect the jumper wire, restart the ice machine, (step 1) and then reinstall the jumper wire after the water pump starts.

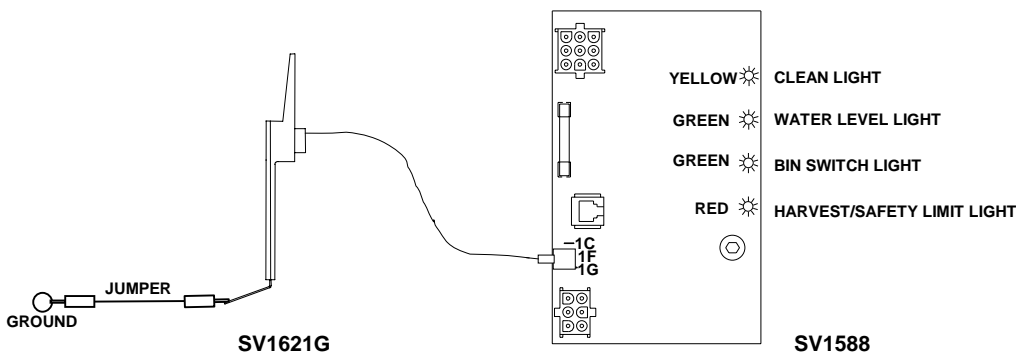

Step 2

Step 2 Jumper wire connected from probe to ground			
Is water flowing into the water trough?	The Water Level Light is:	The Water Inlet Valve Solenoid Coil is:	Cause
no	on	De-Energized	This is normal operation. Do not change any parts.
yes	on	De-Energized	The water inlet valve is causing the problem.
yes	off	Energized	Proceed to step 3.

Continued on next page...

Problem: Water Trough Overfilling During The Freeze Cycle (continued)

Step 3 Allow ice machine to run. Disconnect the water level probe from control board terminal 1F, and connect a jumper wire from terminal 1F to any cabinet ground.

Remember if you are past 6 minutes from starting, the ice machine will go into a freeze cycle water inlet valve safety shut-off mode, and you will be unable to complete this test. If past 6 minutes you must restart this test by disconnecting the jumper wire, restarting the ice machine, (step 1) and then reinstalling the jumper wire to terminal 1F, after the water pump starts.

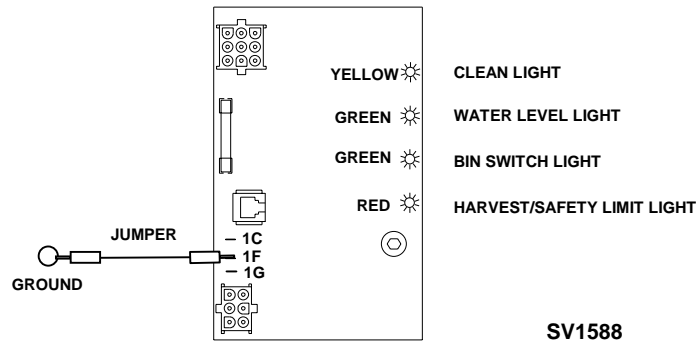

Step 3

Step 3 Jumper wire connected from control board terminal 1F to ground			
Is water flowing into the water trough?	The Water Level Light is:	The Water Inlet Valve Solenoid Coil is:	Cause
no	on	De-Energized	The water level probe is causing the problem. Clean or replace the water level probe.
yes	off	Energized	The control board is causing the problem.
yes	on	De-Energized	The water fill valve is causing the problem.

Problem: Water Will Not Run Into The Sump Trough During The Freeze Cycle

Step 1 Verify water is supplied to the ice machine, and then start a new freeze sequence by moving the ICE/OFF/CLEAN toggle switch to OFF then back to ICE.

Important

This restart must be done prior to performing diagnostic procedures. This assures the ice machine is not in a freeze cycle water inlet valve safety shut-off mode. You must complete the entire diagnostic procedure with-in 6 minutes of starting.

Step 2 Wait until the freeze cycle starts (approximately 45 seconds, the freeze cycle starts when the water pump energizes), and then refer to chart.

Step 2 Checking for normal operation			
Is water flowing into the water trough?	The Water Level Light is:	The Water Inlet Valve Solenoid Coil is:	Cause
yes	off	Energized	This is Normal Operation don't change any parts
no	on or off	Energized Or De-Energized	Proceed to step 3

Step 3 Leave the ice machine run, then disconnect the water level probe from control board terminal 1F.

Important

For the test to work properly you must wait until the freeze cycle starts, prior to disconnecting the water level probe. If you restart the test you must reconnect the water level probe, restart the ice machine, (step 1) and then disconnect the water level probe after the water pump starts.

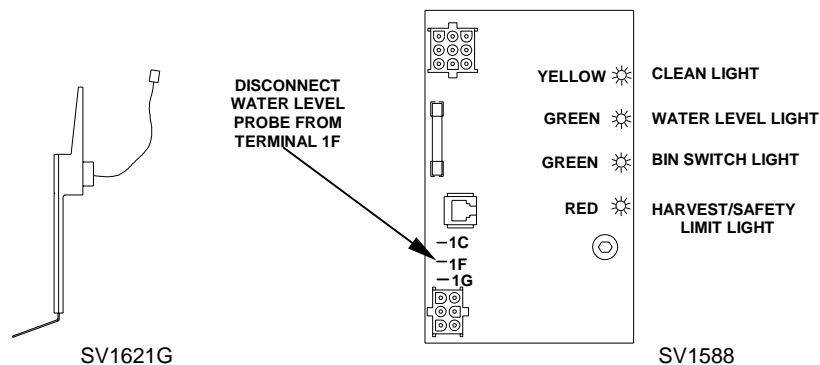

Step 3 Disconnect water level probe from control board terminal 1F			
Is water flowing into the water trough?	The Water Level Light is:	The Water Inlet Valve Solenoid Coil is:	Cause
yes	off	Energized	The water level probe is causing the problem. Clean or replace the water level probe.
no	off	Energized	The water inlet valve is causing the problem.
no	on or off	De-Energized	The control board is causing the problem.

P520/P530 Tubing Diagram Typical Installation

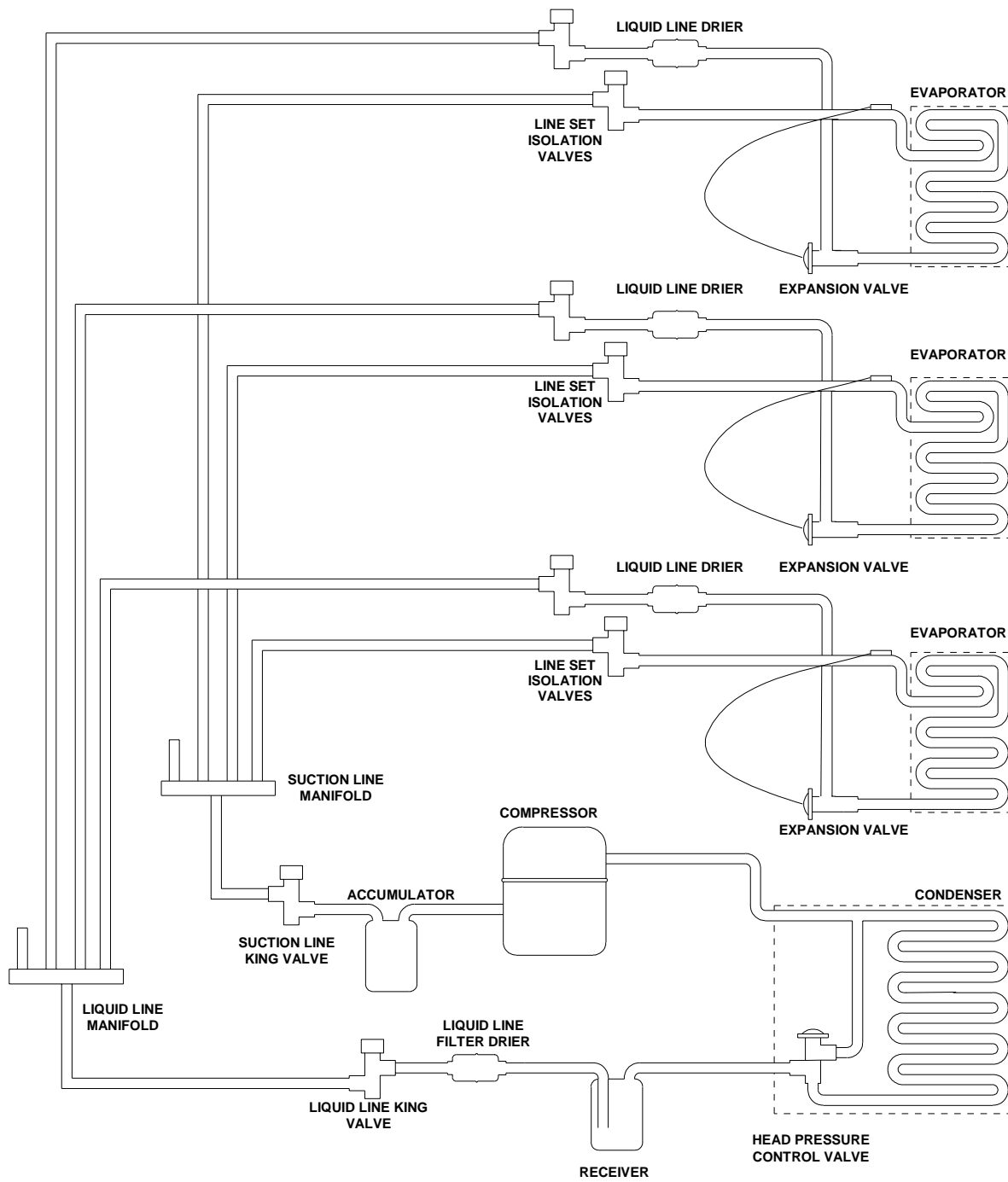

SV1726A

24 Hour Production Charts P520/P530 ICE MACHINES

Ice machine freeze and harvest times will vary depending on the number of ice machines operating, and which stage of a cycle each machine is in. With an ambient temperature of 90°F and water temperature of 50°F, freeze times will range from 8 minutes* with one ice machine operating, to 22 minutes* with 4 ice machines operating. * Based on a slab weight of 4.02lb to 4.12lbs.

Individual Ice Capacity (Lb./24 Hour)
@ 90F Ambient/50F Water

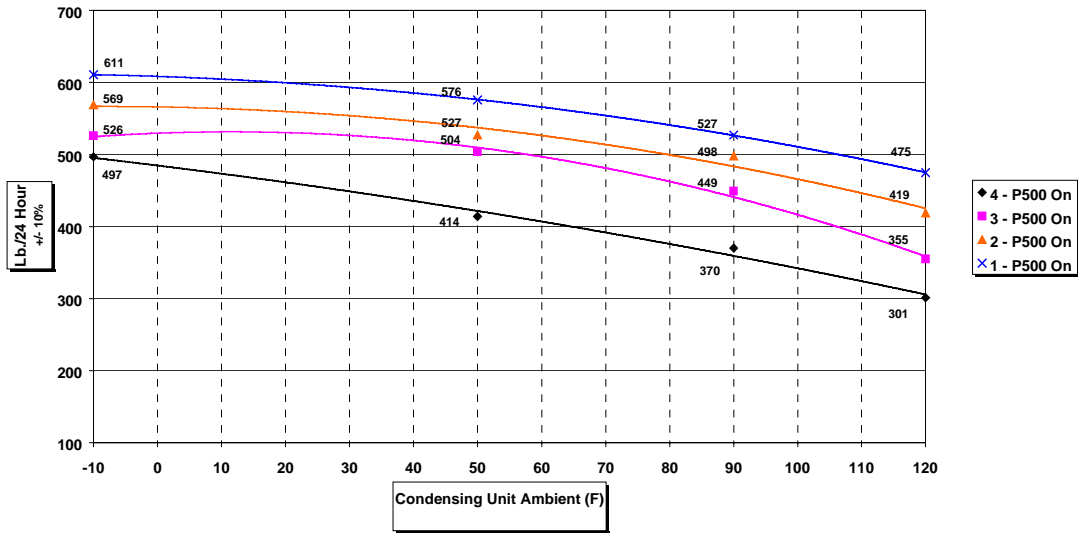

Total Ice Capacity (Lb./24 Hour)
@ 90F Ambient/50F Water

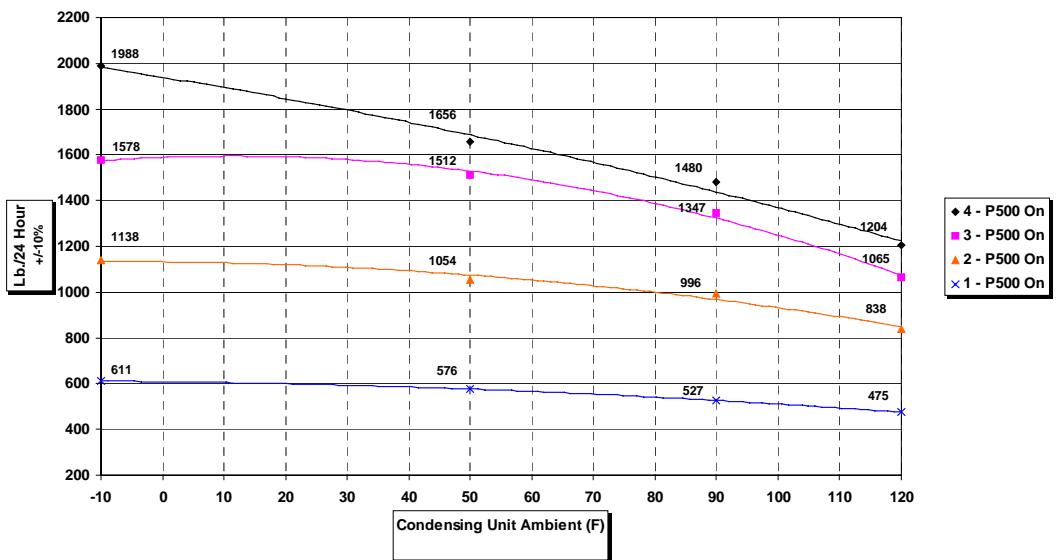

P520/P530 ICE MACHINES

Individual Ice Capacity (Lb./24 Hour)
@ 90F Ambient/70F Water

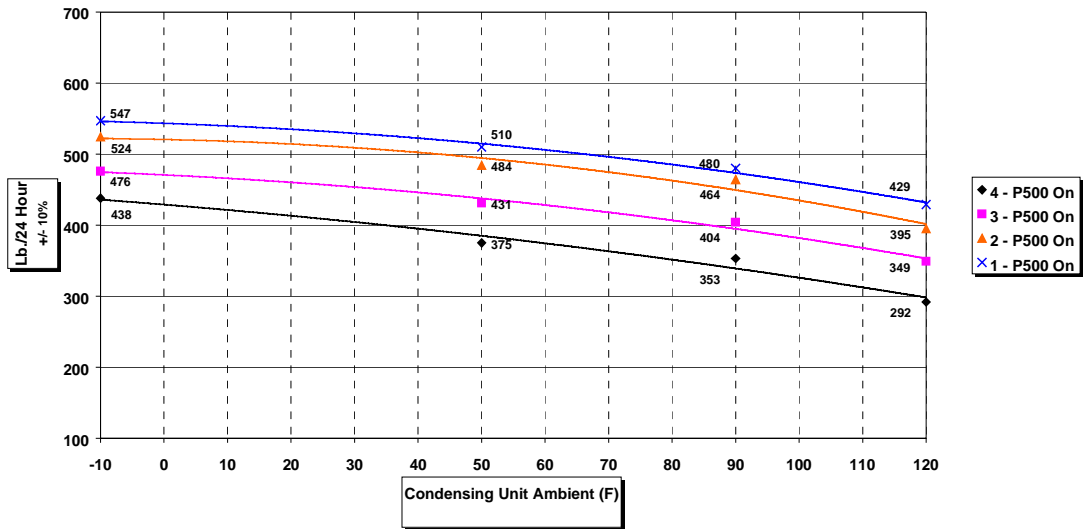

Total Ice Capacity (Lb./24 Hour)
@ 90F Ambient/70F Water

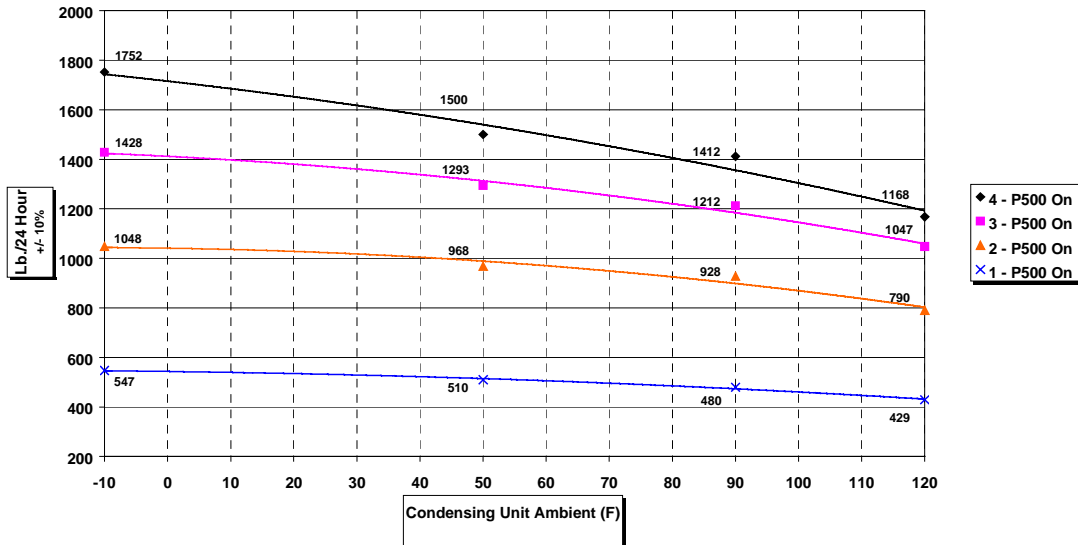

P520/P530 ICE MACHINES

Individual Ice Capacity (Lb./24 Hour)
@ 90F Ambient/90F Water

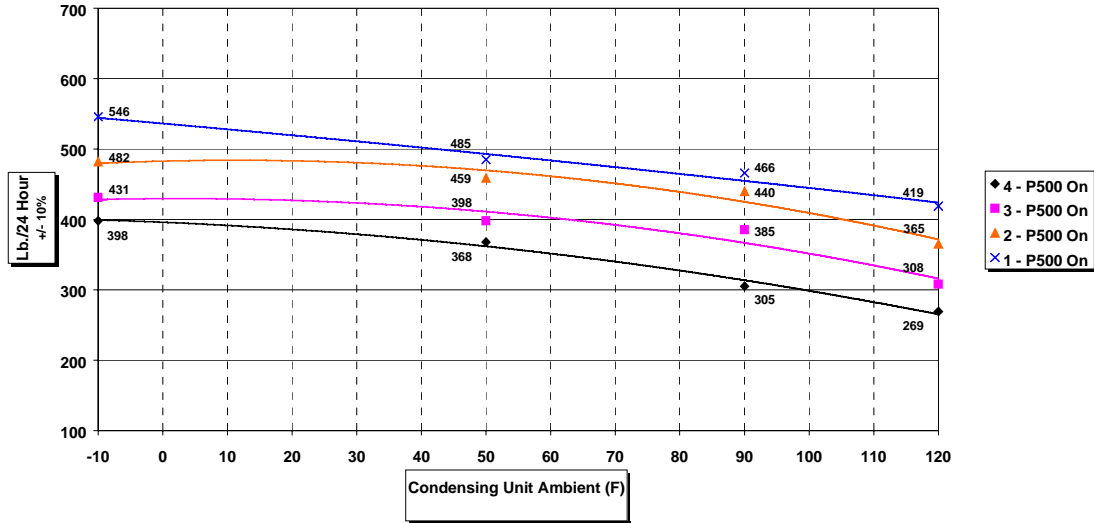

Total Ice Capacity (Lb./24 Hour)
@ 90F Ambient/90F Water

