



## **J Model Ice Machines**

# **Installation & Owner/Operator Use and Care Guide**

Thank you for selecting a Maniowoc Ice Machine, the dependability leader in ice making equipment and related products. With proper installation, care and maintenance, your new Maniowoc Ice Machine will provide you with many years of reliable and economic performance.

We reserve the right to make product improvements at any time. Specifications and design are subject to change without notice.

## IMPORTANT

Proper installation, care and maintenance are essential for maximum ice production and trouble-free operation of your Manitowoc Ice Machine. You should read and understand this Installation & Owner/Operator Use and Care Guide. It contains valuable care and maintenance information.

Routine adjustments and maintenance procedures outlined in this guide are not covered by warranty.

If you encounter problems not covered by this guide, feel free to contact Manitowoc Ice, Inc. We will be happy to provide whatever assistance you may need.

### Contact Your Manitowoc Dealer for These Optional Accessories.

**BIN CASTER** - Replaces standard legs.

**STACKING KITS** - As your business grows and your ice needs increase, Manitowoc stack-on capability can double your daily ice production without using additional space.

**ICE BAGGER** - Maximize profits from bagged ice sales with this convenient accessory. This sturdy unit rests on the bin door frame, and adapts for left or right side filling.

**ICE DEFLECTOR** - See warning below.

**TRI-LIMINATOR WATER FILTER SYSTEM** - Engineered specifically for Manitowoc Ice Machines, Tri-Liminator water filters are an efficient, dependable, and affordable method of inhibiting scale formation, filtering sediment and removing chlorine taste and odor.

**MANITOWOC CLEANER/SANITIZER** - Manitowoc Ice Machine Cleaner and Sanitizer are available in convenient 16 oz bottles. These are the only approved cleaner and sanitizer compatible for use with Manitowoc products.

**DISPENSERS** - Counter top dispensers are ideal for cafeterias and many types of self-service facilities. Manitowoc auto-fill, floor-standing ice dispensers meet the strict sanitary requirements of the food service, lodging and health care industries.

**AUCS™ AUTOMATIC CLEANING SYSTEM** - This accessory virtually eliminates equipment cleaning expense. The AuCS™ Accessory monitors ice making cycles and initiates self cleaning procedures automatically.

**WARNING:** All Manitowoc Ice Machines require the ice storage system (Bin, Dispensers or others) to incorporate an ice deflector. The J1300 and J1800 series Ice Machines require the addition of Manitowoc Ice Deflector Kit K00092 when installing with non-Manitowoc ice storage systems.

**Other Manitowoc Ice Machines:** Prior to using a non-Manitowoc ice storage system, contact the manufacturer of such to assure their ice deflector is designed for use with Manitowoc Ice Machines.

## CONTENTS

### Warranty

Model Numbers . . . . .	1-1
Location of Model and Serial Numbers . . . . .	1-2
Owner Warranty Registration Cards . . . . .	1-3
Warranty Coverage . . . . .	1-3
Exclusions from Warranty Coverage . . . . .	1-3
Authorized Warranty Service . . . . .	1-3
Service Calls . . . . .	1-3

### Installation

General . . . . .	2-1
Dimensions . . . . .	2-2
Location of Ice Machine . . . . .	2-6
Mounting Two Ice Machines on a Single Storage Bin . . . . .	2-6
Ice Machine Heat of Rejection . . . . .	2-6
Leveling Ice Storage Bin . . . . .	2-7
Electrical Service . . . . .	2-9
Electrical Fuse Size/Circuit Ampacity . . . . .	2-9
Electrical Wiring Connections . . . . .	2-11
Self-Contained Electrical Connections . . . . .	2-11
Remote Electrical Connections . . . . .	2-12
Water Supply/Drains . . . . .	2-13
Cooling Tower Applications - Water Cooled Models . . . . .	2-13
Water Connections and Drains . . . . .	2-14
Air-Cooled Air Baffle . . . . .	2-15
Air-Cooled Condenser Filter . . . . .	2-15
Remote Condenser/Line Set Installation . . . . .	2-16
Refrigerant Charge . . . . .	2-16
Routing of Line Sets . . . . .	2-17
Maximum Line Set Distance Formula . . . . .	2-18
Lengthening or Reducing Line Set Length . . . . .	2-19
Connection of Line Set . . . . .	2-19
Receiver Service Valve . . . . .	2-19
Installation Checklist . . . . .	2-21
Before Starting Ice Machine . . . . .	2-21
AuCS™ Automatic Cleaning System Accessory . . . . .	2-21

**Owner/Operator Use and Care Guide**

Basic Components and Operation . . . . .	3-1
Component Identification . . . . .	3-1
Ice Making Sequence of Operation . . . . .	3-2
Initial Start-Up or after Automatic Shut-Off . . . . .	3-2
Freeze Sequence . . . . .	3-2
Harvest Sequence . . . . .	3-2
Automatic Shut-Off . . . . .	3-2
Operational Checks . . . . .	3-3
Water Level . . . . .	3-3
Ice Thickness . . . . .	3-3
Maintenance . . . . .	3-4
Maintenance Guidelines Chart . . . . .	3-4
General Ice Machine Inspection . . . . .	3-4
Exterior Cleaning . . . . .	3-4
Cleaning the Condenser . . . . .	3-5
Air-Cooled Condenser - Self-Contained and Remote Models . . . . .	3-5
Water-Cooled Condenser and Water Regulating Valve . . . . .	3-5
Interior Cleaning/Sanitizing - SeCS™ Self Cleaning System . . . . .	3-6
Cleaning Procedures . . . . .	3-6
Sanitizing Procedures . . . . .	3-7
Cancel Self-Cleaning (or Sanitizing) After Cycle Has Started . . . . .	3-7
AuCS™ Automatic Cleaning System Accessory . . . . .	3-8
Removal of Parts for Cleaning/Sanitizing . . . . .	3-9
Water Dump Valve Removal . . . . .	3-10
Water Pump . . . . .	3-11
Ice Thickness Probe . . . . .	3-11
Water Trough . . . . .	3-11
Float Valve . . . . .	3-11
Water Distribution Tube . . . . .	3-12
Water Curtain . . . . .	3-12
Water Treatment - Filtration . . . . .	3-13
Replacement Procedure . . . . .	3-13
Removal from Service - Winterization . . . . .	3-14
Self-Contained Air-Cooled Machines . . . . .	3-14
Water-Cooled Machines . . . . .	3-14
Remote Machines . . . . .	3-14
AuCS™ Automatic Cleaning System Accessory . . . . .	3-14
Before Calling for Service Checklist . . . . .	3-15
Safety Limit Feature . . . . .	3-16
Ice Machine Warranty . . . . .	3-18

## Model Numbers

This Installation and Owner/Operator Use and Care Guide covers the following models:

Self-Contained Air-Cooled	Self-Contained Water-Cooled	Remote
--	--	--
--	--	--
JR0250A	JR0251W	--
JD0252A	JD0253W	--
JR0320A	JR0321W	--
JD0322A	JD0323W	--
JY0324A	JY0325W	--
JR0420A	JR0421W	--
JD0422A	JD0423W	--
JY0424A	JY0425W	--
JR0200A	JR0201W	--
JD0202A	JD0203W	--
JY0204A	JY0205W	--
JR0450A	JR0451W	JR0490N
JD0452A	JD0453W	JD0492N
JY0454A	JY0455W	JY0494N
JR0600A	JR0601W	JR0690N
JD0602A	JD0603W	JD0692N
JY0604A	JY0605W	JY0694N
JR0800A	JR0801W	JR0890N
JD0802A	JD0803W	JD0892N
JY0804A	JY0805W	JY0894N
JR1000A	JR1001W	JR1090N
JD1002A	JD1003W	JD1092N
JY1004A	JY1005W	JY1094N
JR1300A	JR1301W	JR1300N
JD1302A	JD1303W	JD1302N
JY1304A	JY1305W	JY1304N
JR1800A	JR1801W	JR1800N
JD1802A	JD1803W	JD1802N
JY1804A	JY1805W	JY1804N

\* For a stainless steel exterior, add an "S" suffix to the model number - example: JY1304AS

## Location of Model and Serial Numbers

Record the model and serial numbers of your Ice Machine and bin or dispenser in the space provided below. These numbers are required when requesting information from your local Manitowoc distributor, service representative, or Manitowoc Ice, Inc.

The model and serial numbers are listed on the OWNER WARRANTY REGISTRATION CARD. They are also listed on the MODEL/SERIAL NUMBERS DECAL affixed to the inside of the Ice Machine and on the back panel of the bin.

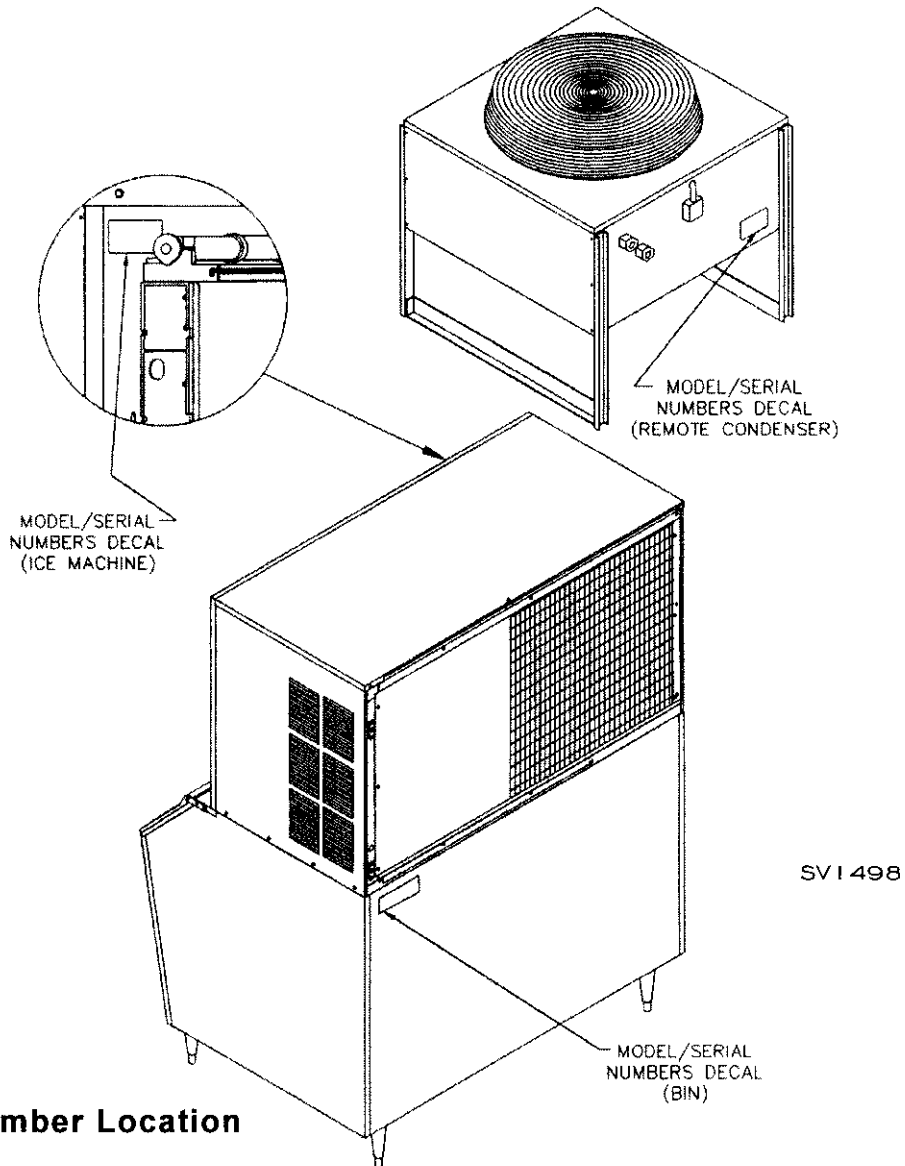

## Model and Serial Number Location

	Ice Machine	Bin or Dispenser	Remote Condenser	AuCST <sup>TM</sup> Accessory
Model #	_____	_____	_____	_____
Serial #	_____	_____	_____	_____

## Owner Warranty Registration Card

The packet containing this guide also includes warranty information. Warranty coverage begins the day your new Ice Machine is installed.

**Important:** Complete and mail the Owner Registration card as soon as possible to validate the installation date.

If you do not return your OWNER REGISTRATION CARD, Manitowoc will use the date of sale to the Manitowoc Distributor as the first day of warranty coverage for your new Ice Machine.

## Warranty Coverage

The following warranty outline is provided for your convenience. For a detailed explanation, read the warranty bond on the inside back cover of this guide.

Contact your local Manitowoc representative or Manitowoc Ice, Inc. if you need further warranty information.

### Parts

1. Manitowoc warrants the Ice Machine against defects in materials and workmanship, under normal use and service, for three (3) years from the date of original installation.
2. The evaporator and compressor are covered by an additional two (2) year (five years total) warranty beginning on the date of the original installation.

### Labor

1. Labor required to repair or replace defective components is covered for three (3) years from the date of original installation.
2. The evaporator is covered by an additional two (2) year (five years total) labor warranty beginning on the date of the original installation.

## Exclusions from Warranty Coverage

The following items are not included in the Ice Machine's warranty coverage.

1. Normal maintenance, adjustments and cleaning as outlined in this manual.
2. Repairs due to unauthorized modifications to the Ice Machine, or the use of nonstandard parts without prior written approval from Manitowoc Ice, Inc.
3. Damage caused by improper installation of the Ice Machine, electrical supply or drainage, or damage caused by floods, storms, or other acts of God.
4. Premium labor rates due to holidays, overtime, etc.; travel time; flat rate service call charges; mileage and miscellaneous tools and material charges not listed on the payment schedule. Additional labor charges resulting from the inaccessibility of the Ice Machine are also excluded.
5. Parts or assemblies subjected to misuse, abuse, neglect or accidents.
6. Damage or problems caused by installation, cleaning and/or maintenance procedures inconsistent with the technical instructions provided in the Installation Manual and this Owner/Operator Use and Care Guide.

## Authorized Warranty Service

To comply with the provisions of the warranty, a refrigeration service company, qualified and authorized by your Manitowoc distributor, or a Contracted Service Representative must perform the warranty repair.

**Note:** If the dealer you purchased the Ice Machine from IS NOT authorized to perform warranty service, contact your Manitowoc distributor or our Wisconsin headquarters for the name of the nearest authorized service representative.

## Service Calls

Normal maintenance, adjustments and cleaning as outlined in this manual are not covered by warranty. If you have followed the procedures listed in this guide and followed the "Before Calling for Service Checklist" on Page 3-15, and the Ice Machine still does not perform properly, call your authorized service company.

# Installation

## General

These instructions are provided to assist the qualified installer. Check your local Yellow Pages for the name of the nearest Manitowoc Ice Machine Distributor, or call Manitowoc Ice, Inc. for information regarding installation and start-up services.

**Important:** Failure to follow these installation guidelines may affect warranty coverage.

## SAFETY PRECAUTIONS

- The Ice Machine must be installed according to these Installation Instructions.
- Water service, drains, and electrical service connections must comply with applicable local and state codes.
- Disconnect electrical service before servicing.
- Read and understand all instructions before placing the Ice Machine into service.

**Ice Machine Dimensions**  
All dimensions are in inches.

**J320/J420 Ice Machines**

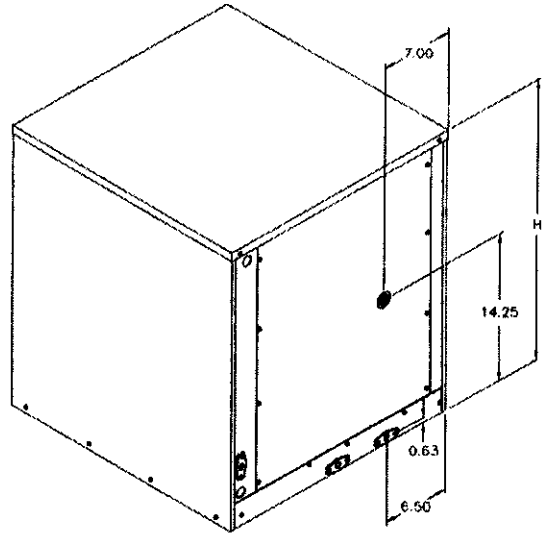

SVI 270

Ice Machine	Dimension H
J320	20 in
J420	25 in

**J250 Ice Machine**

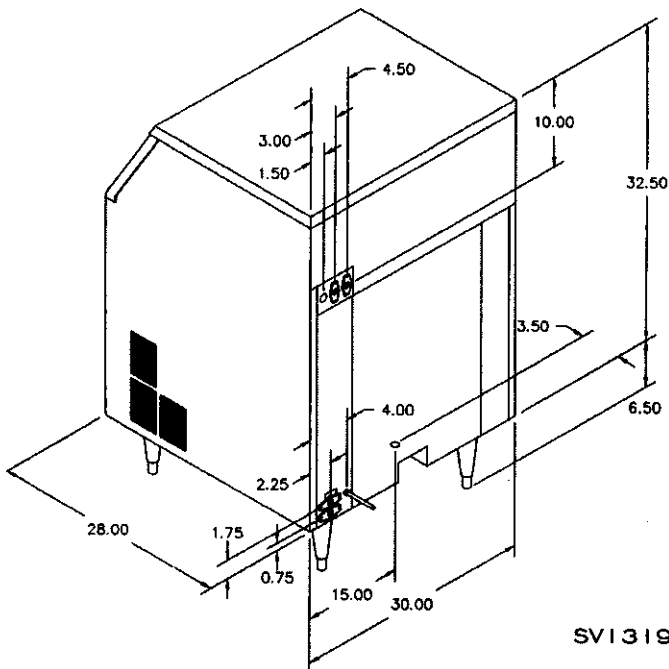

SVI 1319

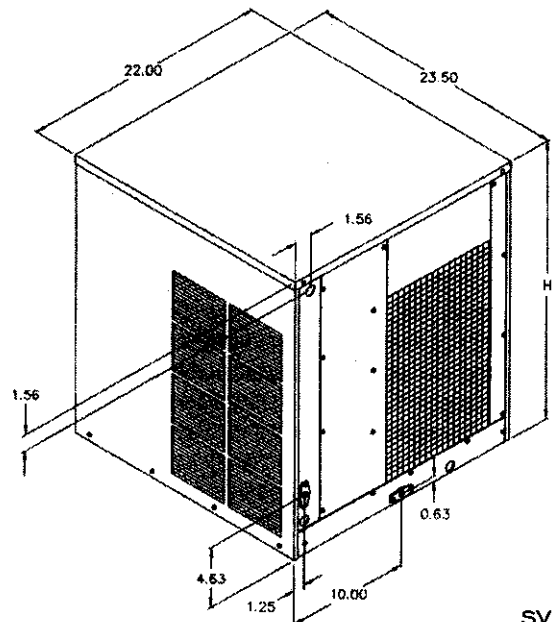

SVI 271

**Dimensions**  
All dimensions are in inches.

**J200 - J1000 Ice Machines**

SVI 181

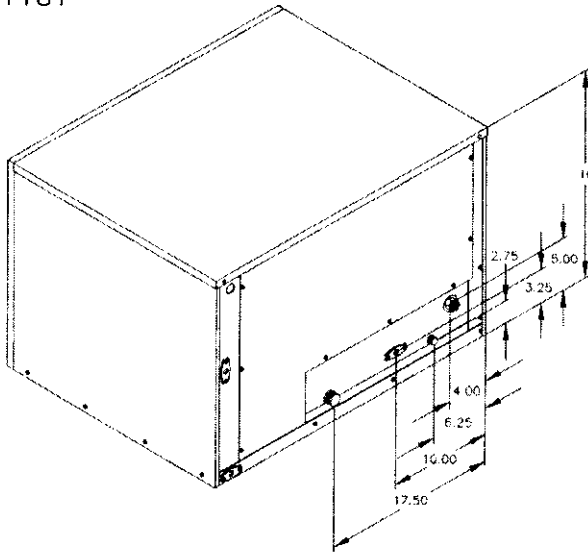

Ice Machine	Dimension H
J200	16.50 in
J450	20.00 in
J600	20.00 in
J800	25.00 in
J1000	28.00 in

**J1300/J1800 Ice Machines**

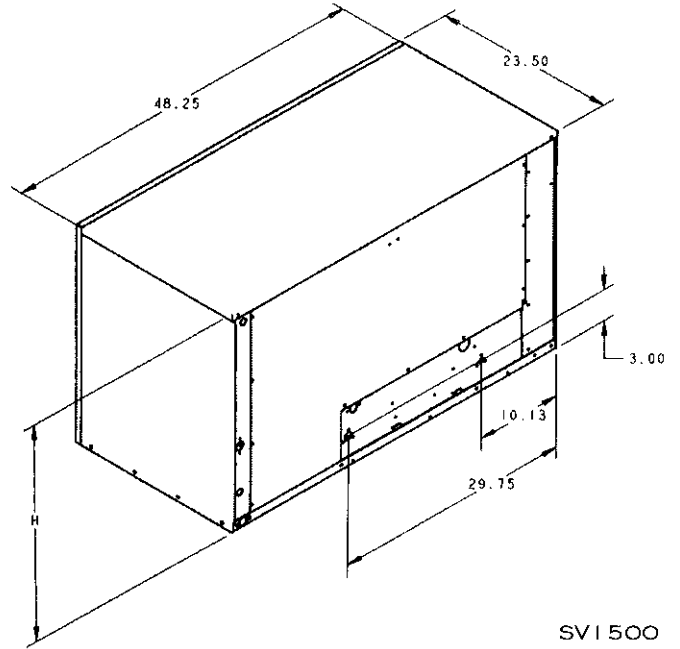

SVI 500

Ice Machine	Dimension H
J1300	28.00 in
J1800	28.00 in

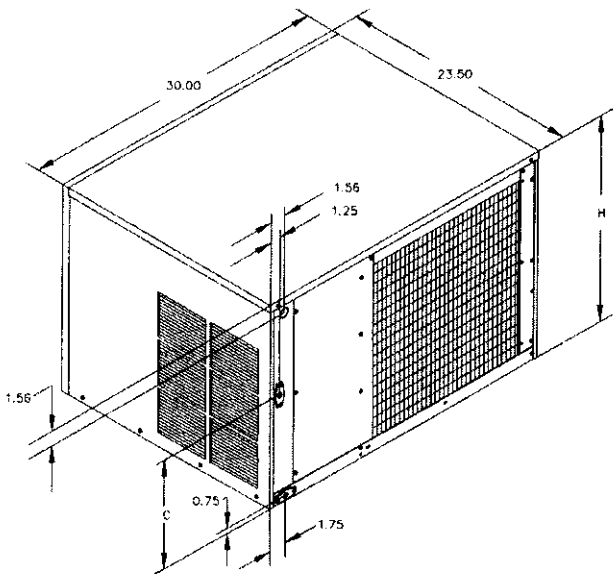

SVI 180

Ice Machine	Dimension C
J200	7.25 in
J450, J600	10.50 in
J800, J1000	

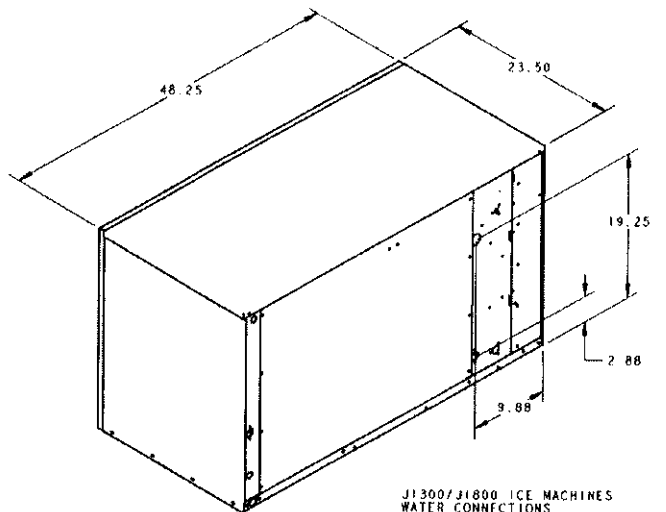

J1300/J1800 ICE MACHINES  
WATER CONNECTIONS

SVI 501

**Ice Storage Bin Dimensions**  
All dimensions are in inches.

**C170/C400/C470/C570  
Ice Storage Bins**

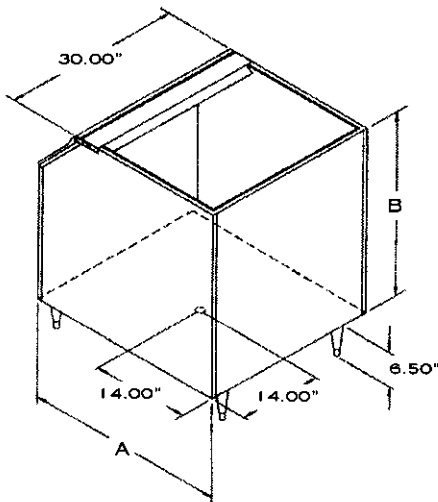

SVI 187

**C730 Ice Storage Bin**

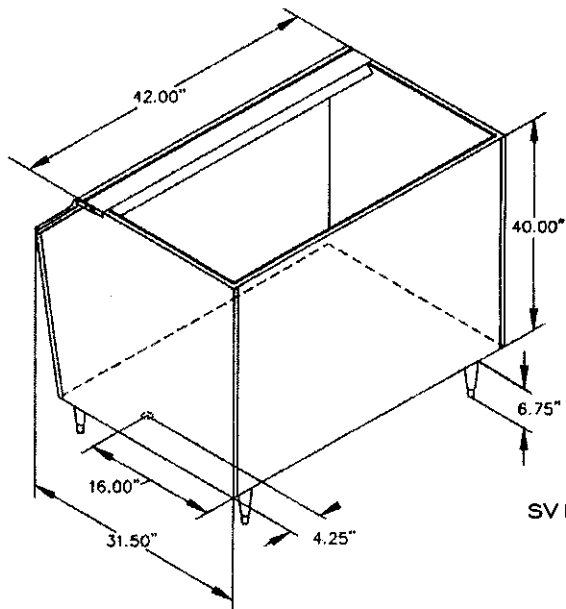

SVI 497

Bin Model	Dimension A	Dimension B
C170	28.25 in	19.06 in
C400	34.00 in	31.37 in
C470	29.50 in	44.00 in
C570	34.00 in	44.00 in

**C970 Ice Storage Bin**

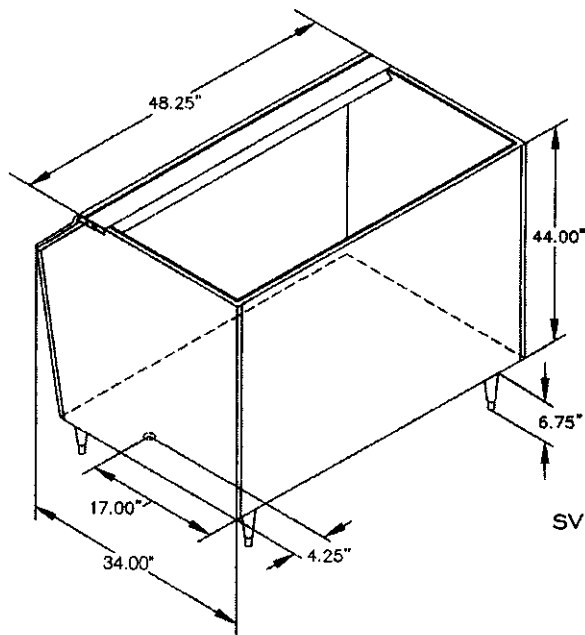

SVI 296

**C320/C420  
Ice Storage Bins**

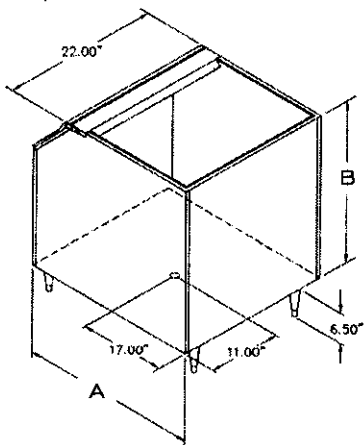

SVI 272

Bin Model	Dimension A	Dimension B
C320	34.00 in	32.00 in
C420	34.00 in	44.00 in

**WARNING:** All Manitowoc Ice Machines require the ice storage system (Bin, Dispensers or others) to incorporate an ice deflector. The J1300 and J1800 series Ice Machines require the addition of Manitowoc Ice Deflector Kit K00092 when installing with non-Manitowoc ice storage systems.

Other Manitowoc Ice Machines: Prior to using a non-Manitowoc ice storage system, contact the manufacturer of such to assure their ice deflector is designed for use with Manitowoc Ice Machines.

# Remote Condenser Dimensions

All dimensions are in inches.

## JC0495/JC0895/JC1095/JC1395

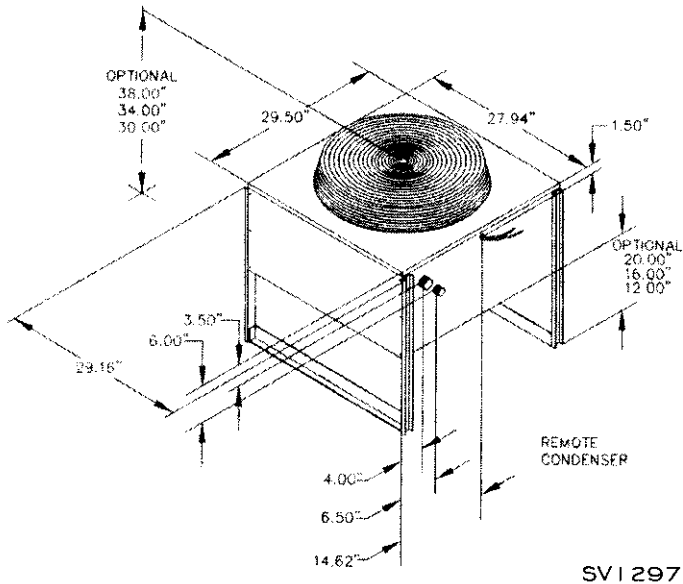

## JC1895

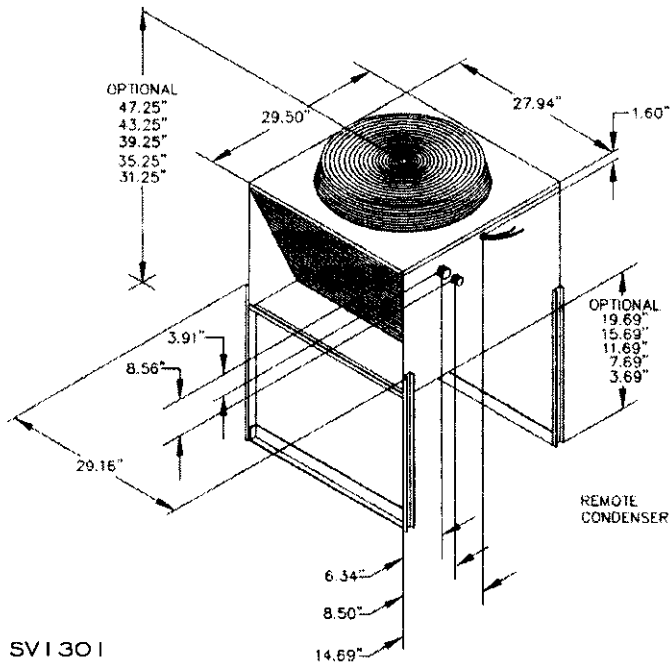

## Location of Ice Machine

Locate your machine away from heat-generating equipment and direct sunlight.

Air Temperature Around Ice Machine	
Minimum	Maximum
35° F (1.7° C)	110° F (43.3° C)

**Caution:** The Ice Machine must be protected if it will be subjected to temperatures below 32° F (0° C). Failure caused by exposure to freezing temperatures is not covered by the warranty. See Removal From Service - Winterization in the Owner/Operator Use and Care Guide, Page 3-14.

Manitowoc Ice Machines operate most efficiently when:

### Located In a Contaminant-Free Area

Air-cooled models are particularly vulnerable, and should be installed in an area that is free of air-borne contaminants.

### Provided Clearance at Top, Sides and Rear

Adequate air flow through and around the Ice Machine is essential for maximum ice production and long component part life.

#### *Self-Contained Air-Cooled Models:*

- Eight inches (8 in) (203.20 mm) minimum clearance on the sides and the top.
- Five inches (5 in) (127 mm) minimum clearance in the back.

#### *Water-Cooled and Remote Models:*

There is no minimum clearance required, but 5 in (127 mm) on the top, sides and rear is recommended for efficient operation and servicing.

### Mounting Two Ice Machines On A Single Storage Bin

A stacking kit is required for stacking two Ice Machines. Installation instructions are supplied with the stacking kit.

## Ice Machine Heat of Rejection

Series Ice Machine	Heat of Rejection*	
	Air Conditioning**	Peak
J250	4,000	5,200
J320	4,600	6,200
J420	7,000	9,600
J200	3,800	5,000
J450	7,000	9,600
J600	9,000	13,900
J800	12,400	19,500
J1000	16,000	24,700
J1300	24,000	35,500
J1800	36,000	50,000

\* B.T.U./Hour

\*\* Because the heat of rejection varies during the ice making cycle, the figure shown is an average.

Ice Machines, like other refrigeration equipment, reject heat through the condenser. It is helpful to know the amount of heat rejected by the Ice Machine when sizing air conditioning equipment where self-contained air-cooled Ice Machines are installed. This information is also necessary when evaluating the benefits of using water-cooled or remote condensers to reduce air conditioning loads. The amount of heat added to an air conditioned environment by an Ice Machine using water-cooled or a remote condenser is negligible. Knowing the amount of heat rejected is also important when sizing a cooling tower for a water-cooled condenser unit. The peak figure is used for sizing the cooling tower.

## Leveling the Ice Storage Bin

1. Screw the leveling legs onto the bottom of the bin and screw the "foot" of each leg in as far as possible.
2. Move the bin into its final position.
3. Level the bin to assure that the bin door closes and seals properly. Turn the foot of the appropriate leg(s) to level the bin. Use a level on top of the bin when leveling the bin.

**Note:** An optional caster assembly is available in place of legs. Installation instructions are supplied with the casters.

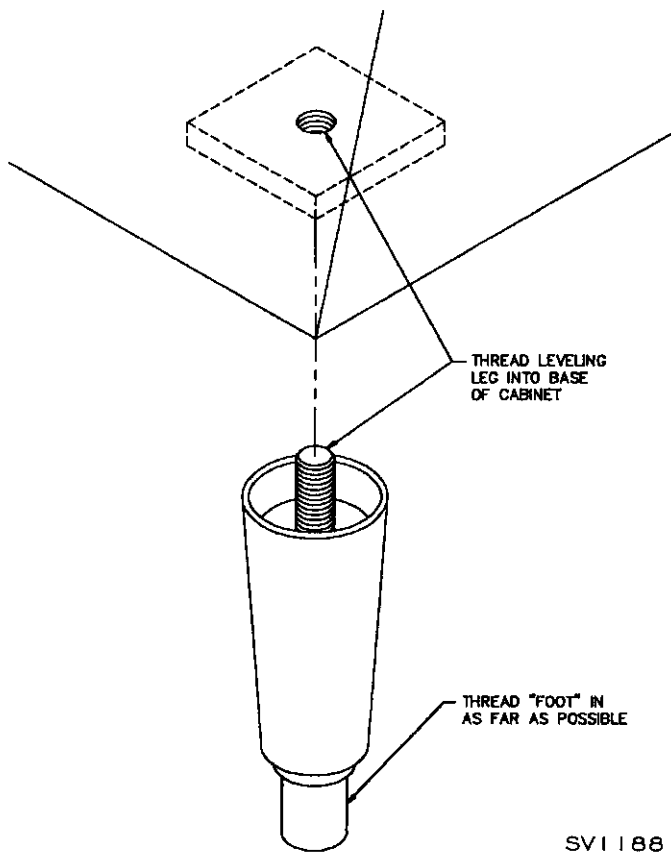

**Leveling Leg and Foot**



## Electrical Service

### Electrical Fuse Size/Circuit Ampacity

**Caution:** All wiring must conform to local, state, and national codes.

#### Voltage

The maximum allowable voltage variation is +/- 10% of the rate voltage at Ice Machine start-up when the electrical load is highest.

**WARNING:** The Ice Machine must be grounded in accordance with the National and Local Electrical Code.

#### Fuse/Circuit Breaker

A separate fuse/circuit breaker must be provided for each Ice Machine. Circuit breakers must be H.A.C.R. rated. H.A.C.R. rating does not apply in Canada.

#### Minimum Circuit Ampacity

The minimum circuit ampacity is used to help select the wire size of the electrical supply.\*

The wire size, or gauge, is also dependent upon location materials used, length of run, etc., and therefore must be determined by a qualified electrician.

\* Minimum circuit ampacity is not the Ice Machine's running amp load.

### J150/J250 Ice Machines

Ice Machines with power cord. The power cord is 6 ft (1.83 m) long, with NEMA 5-15P plug configuration.					
Ice Machine	Voltage Phase Cycle	Air-Cooled		Water-Cooled	
		Maximum Fuse/Circuit Breaker	Total Amps	Maximum Fuse/Circuit Breaker	Total Amps
-	-	-	-	-	-
J250	115/1/60	15	8.8	15	8.0

**Caution:** Never use an extension cord. If an outlet is not in reach of the Ice Machine's power cord, have a proper amperage outlet wired closer.

Ice Machines requiring direct wiring (no power cord).					
Ice Machine	Voltage Phase Cycle	Air-Cooled		Water-Cooled	
		Maximum Fuse/Circuit Breaker	Minimum Circuit Amps	Maximum Fuse/Circuit Breaker	Minimum Circuit Amps
-	-	-	-	-	-
	-	-	-	-	-
J250	208-230/1/60	15	4.8	15	4.2
	230/1/50	15	4.8	15	4.2

### J320/J420 Ice Machines

Ice Machine	Voltage Phase Cycle	Air-Cooled		Water-Cooled	
		Maximum Fuse/Circuit Breaker	Minimum Circuit Amps	Maximum Fuse/Circuit Breaker	Minimum Circuit Amps
J320	115/1/60	15	11.3	15	10.9
	208-230/1/60	15	4.8	15	4.2
	230/1/50	15	4.6	15	4.0
J420	115/1/60	20	12.7	20	11.8
	208-230/1/60	15	7.8	15	7.4
	230/1/50	15	5.7	15	5.4

### J200 to J1000 Ice Machines

Ice Machine	Voltage Phase Cycle	Air-Cooled		Water-Cooled		Remote	
		Maximum Fuse/Circuit Breaker	Minimum Circuit Amps	Maximum Fuse/Circuit Breaker	Minimum Circuit Amps	Maximum Fuse/Circuit Breaker	Minimum Circuit Amps
J200	115/1/60	15	10.5	15	10.0	N/A	N/A
	208-230/1/60	15	5.4	15	4.8	N/A	N/A
	230/1/50	15	4.8	15	4.2	N/A	N/A
J450	115/1/60	20	12.7	20	11.8	20	13.7
	208-230/1/60	15	7.8	15	7.4	N/A	N/A
	230/1/50	15	5.7	15	5.4	N/A	N/A
J600	208-230/1/60	15	7.4	15	6.9	15	8.2
	230/1/50	15	6.4	15	6.1	15	6.5
J800	208-230/1/60	20	11.8	20	11.1	20	12.1
	208-230/3/60	15	7.7	15	6.7	15	7.6
	230/1/50	15	10.7	15	9.9	15	9.7
J1000	208-230/1/60	20	13.3	20	12.3	20	12.8
	208-230/3/60	15	10.1	15	9.1	15	10.3
	230/1/50	15	13.6	15	12.1	15	12.9
J1300	208-230/1/60	30	19.0	30	17.4	30	18.4
	208-230/3/60	20	12.9	20	11.3	20	10.6
	230/1/50	30	19.9	30	18.7	30	18.1
	380-415/3/50	N/A	N/A	N/A	N/A	15	7.3
J1800	208-230/1/60	35	23.8	35	22.2	35	22.3
	208-230/3/60	20	17.0	20	15.4	20	15.1
	230/1/50	35	23.0	35	21.5	35	20.6
	380-415/3/50	N/A	N/A	N/A	N/A	15	9.1

# ELECTRICAL WIRING CONNECTIONS

## Self-Contained Electrical Connections

**Caution:** The diagrams are not intended to show proper wire routing, wire sizing, disconnects, etc., only the correct wire connections. All electrical connections and routing must conform to local and national codes.

### Self-Contained Ice Machine 115/1/60 -OR- 208-230/1/60

ICE MACHINE CONNECTIONS

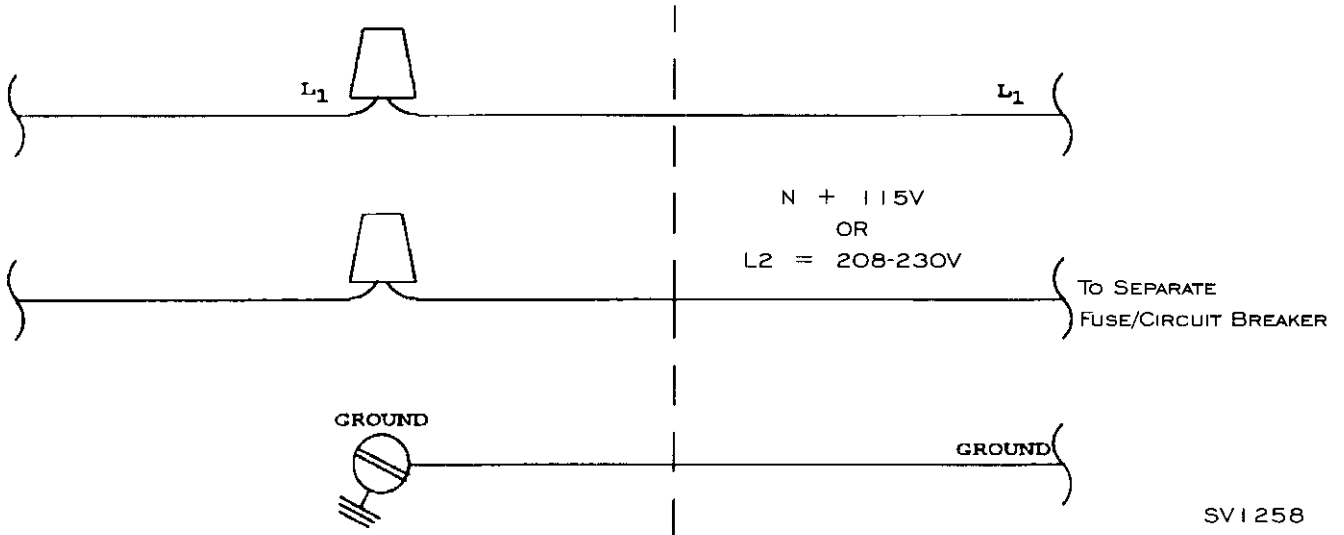

SVI 258

### Self-Contained Ice Machine 208-230/3/60

ICE MACHINE CONNECTIONS

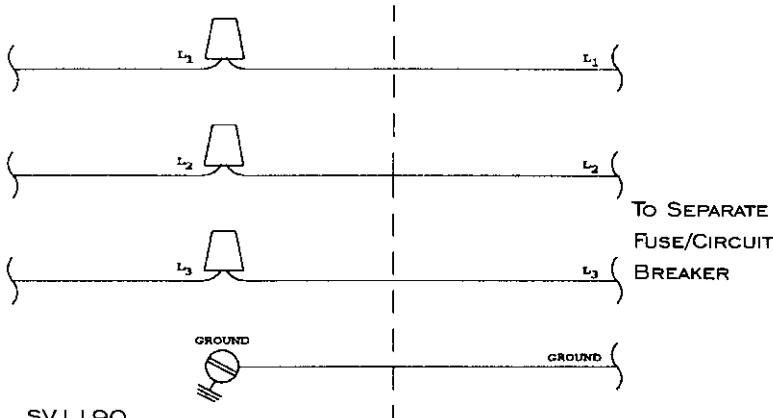

SVI 190

### Self-Contained Ice Machine 230/1/50

ICE MACHINE CONNECTIONS

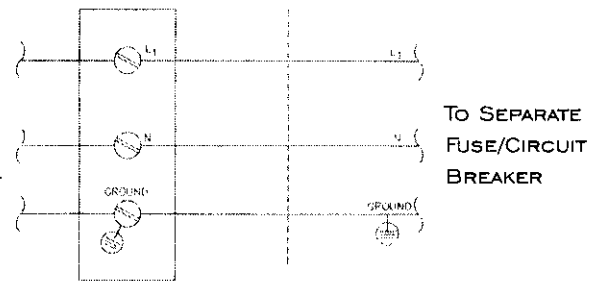

SVI 191

## Self-Contained Electrical Wiring Connections

## Remote Electrical Connections

**Caution:** The diagrams are not intended to show proper wire routing, wire sizing, disconnects, etc., only the correct wire connections. All electrical connections and routing must conform to local and national codes.

**Remote Ice Machine  
115/1/60 -or- 208-230/1/60**

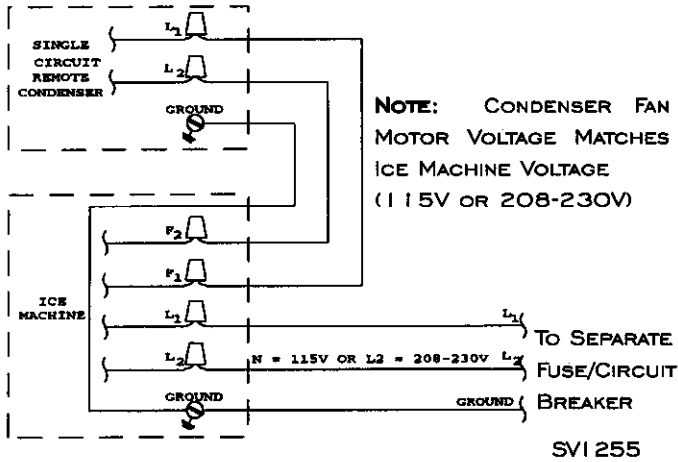

**Remote Ice Machine  
220-240/1/50  
With Single Circuit Model Condenser**

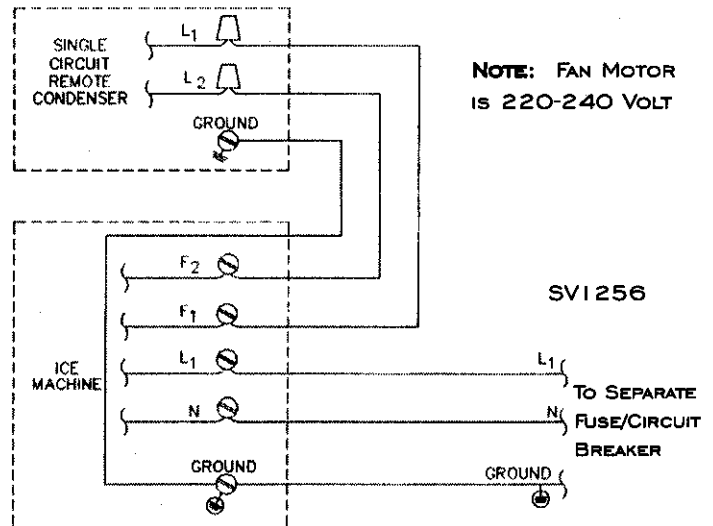

**Remote Ice Machine  
230/1/50  
With Single Circuit Model Condenser**

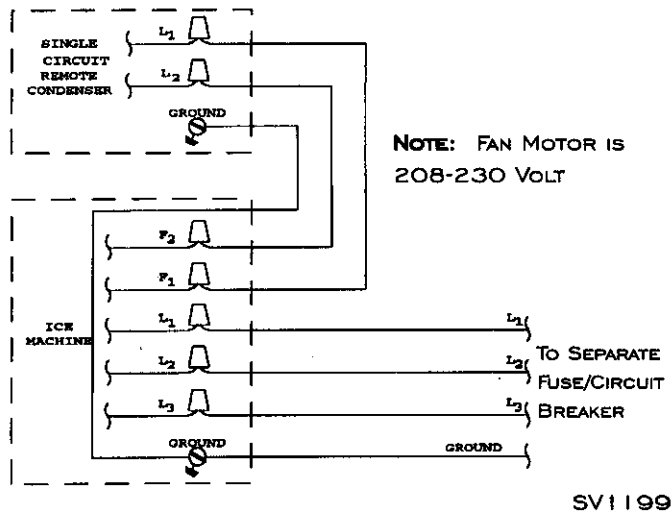

## Remote Electrical Wiring Connections

## Water Supply/Drains

**Caution:** Plumbing must conform to local and state codes.

### Water Supply

Local water conditions may require treatment of the water to inhibit scale formation, filter sediment, and remove chlorine odors and taste.

**Important:** If you are installing a Manitowoc Tri-Liminator Water Filter System, refer to the Installation Instructions supplied with the filter system for ice making water inlet connections.

### Water Inlet Lines

Follow these guidelines to install water inlet lines:

The Ice Machine must not be connected to a hot water supply. Be sure all hot water restrictors installed for other equipment are working. Check valves on sink faucets, dishwashers, etc.

If water pressure exceeds the maximum recommended pressure, obtain a water pressure regulator from your Manitowoc Distributor.

Install a shut-off valve for both the ice making and condenser water lines.

Insulate water inlet lines to prevent condensation.

### Drain Connections

Follow these guidelines when installing drain lines to prevent drain water from flowing back into the Ice Machine and Storage Bin:

Drain lines must have a 1.5 in (38.10 mm) drop for each 5 ft (1.524 m) of run, and must not create any traps.

The floor drain must be large enough to accommodate drainage from all drains.

Run separate Bin and Ice Machine drain lines and insulate them to prevent condensation.

The ice making water drain and bin drain must be vented to the atmosphere. Do not vent the condenser drain on water-cooled models.

### Cooling Tower Applications

#### Water-Cooled Models

A water-cooling tower installation does not require modification of the Ice Machine. The water regulator valve for the condenser continues to control the refrigeration discharge pressure. It is necessary to know the amount of heat rejection and the pressure drop through the condenser and the water valves, inlet and outlet of the Ice Machine, when using a cooling tower on an Ice Machine.

- Water entering the condenser must not exceed 90° F (32.2° C).
- Water flow through the condenser must not exceed 5 gal ( 18.921 L) per minute.
- Allow for a pressure drop of 7 psi (2.392 kg cm<sup>2</sup>) between the condenser water inlet and outlet of the Ice Machine.
- Water exiting the condenser must not exceed 110° F (43.3° C)

## Water Connections and Drains

**Caution:** Plumbing must conform to local and state codes.

Location	Water Temperature	Water Pressure	Female Pipe Fitting (F.P.T.)* Size	Tubing Size Up to Ice Machine Fitting
Ice Making Water Inlet	33° F (0.6° C) min 90° F (32.2° C) max	20 psi min 80 psi max	3/8 in F.P.T.	3/8 in
Ice Making Water Drain	-	1/2 in F.P.T.	1/2 in F.P.T.	1/2 in
Condenser Water Inlet	33° F (0.6° C) min 90° F (32.2° C) max	20 psi min 150 psi max	J1300/J1800 - 1/2 in F.P.T. All Others - 3/8 in F.P.T.	
Condenser Water Drain	-	-	1/2 in F.P.T.	1/2 in
Bin Drain	-	-	3/4 in F.P.T.	3/4 in

\* F.P.T. - Female Pipe Thread

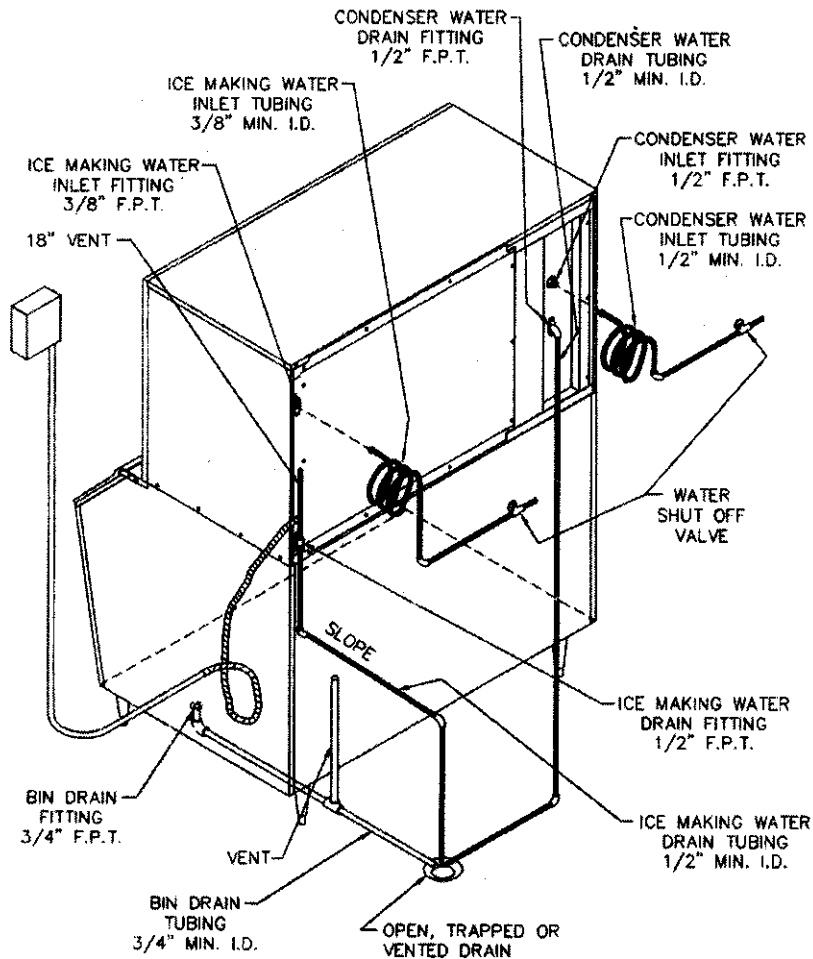

SVI 304

**Typical Water Supply Drain Installation**

## Air-Cooled Baffle

**Note:** The J250 Ice Machine does not incorporate an air baffle.

The air baffle prevents condenser air from recirculating.

### Installation Instructions

1. Remove the two back panel screws next to the condenser.
2. Align the air baffle's mounting holes with the two screw holes and refasten the screws.

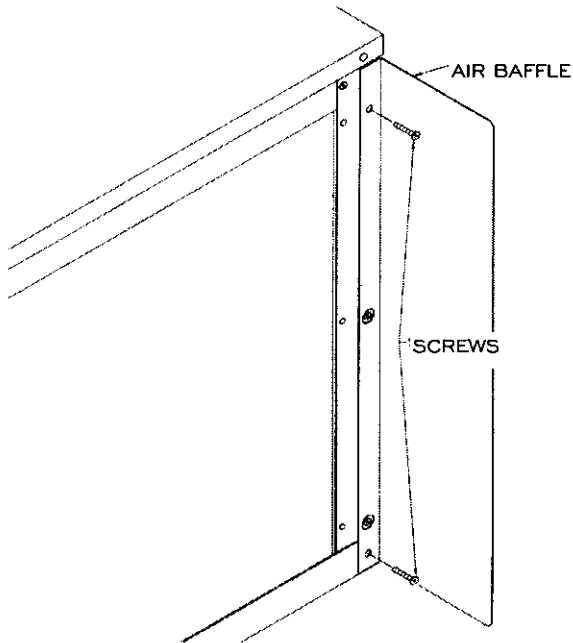

**Air Baffle**

## Air-Cooled Condenser Filter

The filter is a washable aluminum type, designed to catch dust, lint, and grease.

### Installation Instructions:

1. As a guide, center air filter over condenser fin area and mark mounting locations for the channels.
2. Install mounting channels in marked locations.

**Note:** The surfaces must be clean and dry for proper adhesion of mounting channels.

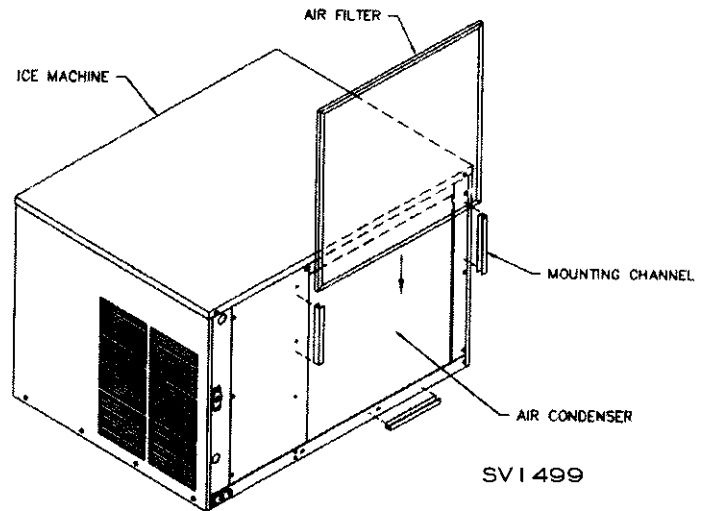

**Condenser Filter**

**Note:** The air filter is factory installed on the J250 model Ice Machine.

## Remote Condenser/Line Set Installation

Ice Machine	Remote Single Circuit Condenser	Line* Set
J490	JC0495	RT-20-R404A
J690	JC0895	RT-35-R404A
J890		RT-50-R404A
J1090	JC1095	RL-20-R404A RL-35-R404A RL-50-R404A
J1390	JC1395	
J1890	JC1895	

*Line Set	Discharge Line	Liquid Line
RT	1/2 in (12.7 mm)	5/16 in (7.937 mm)
RL	1/2 in (12.7 mm)	3/8 in (9.525 mm)

## Remote Ice Machines

### Refrigerant Charge:

All remote Ice Machines ship from the factory with the appropriate refrigerant charge for installation with line sets up to 50 ft ( 15.24 m) in length. The serial tag on the Ice Machine indicates the refrigerant charge from the factory.

Installations using line sets between 50 and 100 ft (15.24 and 30.48 m) may require additional refrigerant at the time of installation. If required, a label located next to the Model/Serial Numbers Decal indicates the need for and provides instructions for adding additional refrigerant to line sets between 50 and 100 ft (15.24 and 30.48 m). If additional refrigerant is not required, the nameplate charge is sufficient for line sets up to 100 ft (30.48 m).

Air Temperature Around the Condenser	
Minimum	Maximum
-20° F (-28.9 C)	130° F (54.4° C)

### IMPORTANT EPA CERTIFIED TECHNICIANS:

If remote line set length is between 50 and 100 ft (15.24 and 30.48 m), add 1.5 lb (24 oz) (.680 kg) of refrigerant to the nameplate charge.

Tubing length: \_\_\_\_\_

Refrigerant added to nameplate: \_\_\_\_\_

New total refrigerant charge: \_\_\_\_\_

\* Typical label shown: The refrigerant charge to be added for line sets between 50 ft and 100 ft varies by model.

Ice Machine Model	Nameplate Charge Total Charge Shipped in Ice Machine	Refrigerant to be Added for Line Sets Between 50 and 100 ft	Never Exceed Limit Maximum System Charge
J490	6.0 lb (96 oz)	0 (None)	6.0 lb (96 oz)
J690	8.0 lb (128 oz)	0 (None)	8.0 lb (128 oz)
J890	8.0 lb (128 oz)	0 (None)	8.0 lb (128 oz)
J1090	9.5 lb (152 oz)	0 (None)	9.5 lb (152 oz)
J1390	12.5 lb (200 oz)	1.5 lb (24 oz)	14.0 lb (224 oz)
J1890	15.0 lb (240 oz)	2.0 lb (32 oz)	17.0 lb (272 oz)

## Routing of Line Sets

### General

Condensers must be mounted horizontally with the fan motor on top.

Remote condenser installations consist of vertical and horizontal line set distances between the machine and condenser. When combined, they must fit within approved guidelines. These guidelines, drawings, and calculation methods must be followed to verify a proper remote condenser installation.

**WARRANTY NOTE:** The sixty (60) month compressor warranty, including the thirty-six (36) month labor replacement warranty, will not apply when the remote Ice Machine is not installed according to specifications, or the refrigeration system is modified with a condenser, heat reclaim device or parts and assemblies other than those manufactured by Manitowoc Ice, Inc., unless Manitowoc Ice, Inc. approves these modifications for specific locations in writing.

### Routing of Line Sets

Follow these guidelines when routing refrigerant lines. This will insure the proper performance and service accessibility to the Ice Machine.

A 2.5 in (63.5 mm) round hole in the wall or roof is needed for tubing routing.

**Note:** Line set end with 90° bend connects to the Ice Machine. The straight end connects to the remote condenser.

1. Make the service loop in the line sets as shown. This permits easy access to the Ice Machine for cleaning and service. Hard ridged copper should not be used at this location.

2. Never form a trap in refrigeration lines. Refrigerant oil must always be free to drain toward the ice maker or the condenser. The trap formed by the service loop is part of the Ice Machine's design.

Excess tubing must be routed in a downward horizontal spiral and supported to assure it does not collapse. Do not coil tubing vertically.

3. Refrigerant lines located outdoors should be kept as short as possible, and must be run to prevent traps.

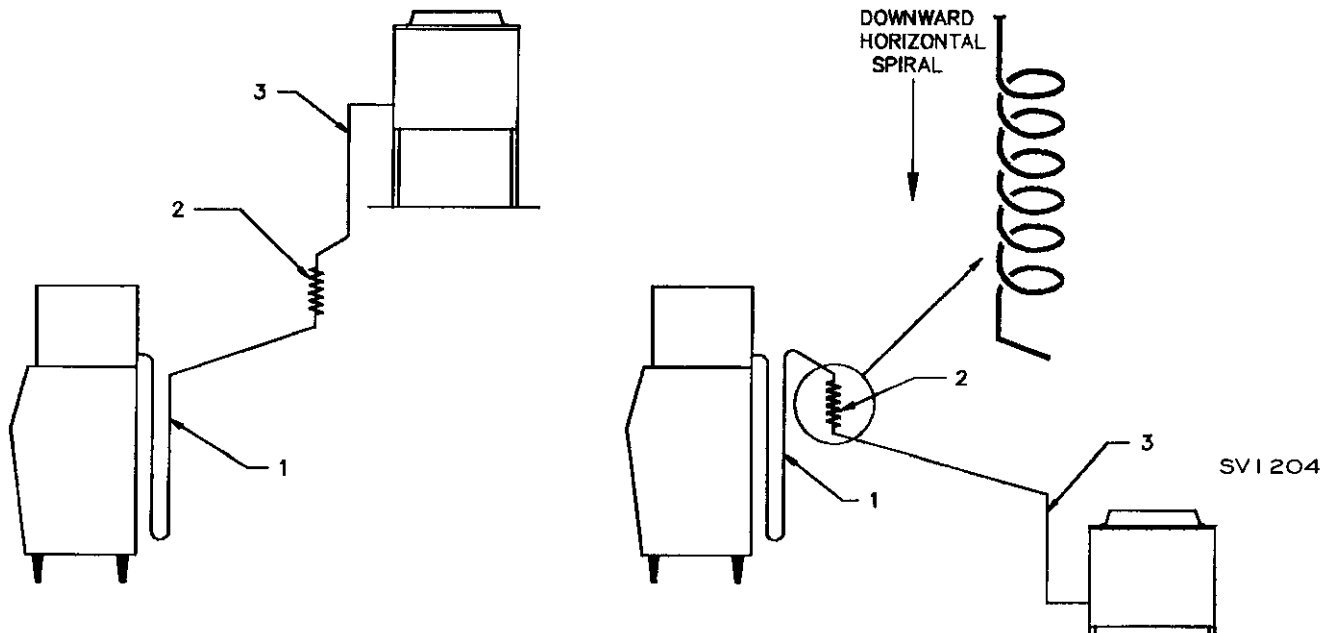

Routing Refrigerant Lines

## Remote Condenser - Maximum Location Distances

### Line Set Length: 100 ft ( 30.48 m) MAXIMUM

The Ice Machine compressor must have the proper oil return. The receiver capacity is designed to hold sufficient charge to operate the Ice Machine in ambient temperatures of -20° F (-28.9° C) to +130° F (54.4° C) with line set lengths up to a measured 100 ft (30.48 m).

### Line Set Rise: 35 ft (10.668 m) MAXIMUM

### Line Set Drop: 15 ft ( 4.572 m) MAXIMUM

Line set rises, drops, or horizontal runs greater than the maximum distance allowed will exceed the compressor start-up and pumping design limits, and will result in poor oil return to the compressor.

### Calculated Line Set Distance: 150 ft (45.72 m) MAXIMUM

To eliminate the combination of rises, drops, and horizontal runs exceeding the compressor start-up and pumping design limits, the following calculations must be made:

Step 1. Insert **Measured Rise** into formula and multiply it by 1.7 to get a calculated rise.

Example: A condenser located 10 ft (3.048 m) above the Ice Machine has a 17 ft (5.1816 m) calculated total (10 ft x 1.7 = 17 ft) (3.048 m x 1.7 = 5.1816 m).

Step 2. Insert **Measured Drop** into formula and multiply by 6.6 to get a calculated drop.

Example: A condenser located 10 ft (3.048 m) below the Ice Machine 10 ft has a 66 ft (20.117 m) calculated total (10 ft x 6.6 = 66 ft) (3.048 m x 6.6 = 20.117 m).

Step 3. Insert **Measured Horizontal Distance** into formula. No calculation is necessary.

Step 4. Add the calculated rise, calculated drop, and horizontal distance together to get the total calculated distance. If 150 ft ( 45.720 m) total calculated distance is exceeded, the condenser must be moved to a new location which permits proper equipment operation.

### Maximum Line Set Distance Formula

- Step 1. Measured Rise (35 ft [10.668 m] Maximum) \_\_\_\_\_ x 1.7 = \_\_\_\_\_ Calculated Rise
- Step 2. Measured Drop (15 ft [4.572 m] Maximum) \_\_\_\_\_ x 6.6 = \_\_\_\_\_ Calculated Drop
- Step 3. Measured Horizontal Distance (100 ft [30.48 m] Maximum) = \_\_\_\_\_ Horizontal Distance
- Step 4. Total Calculated Distance (150 ft [45.720 m] Maximum) = \_\_\_\_\_ Total Calculated Distance

#### Important:

If a line set rise is followed by a line set drop, a second line set rise cannot be made.

-OR-

If a line set drop is followed by a line set rise, a second line set drop cannot be made.

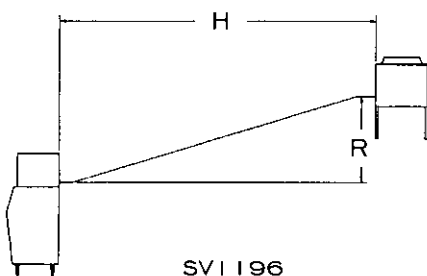

Combination of Rises  
with Horizontal

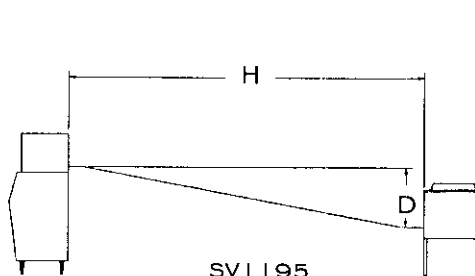

Combination of Drops  
with Horizontal

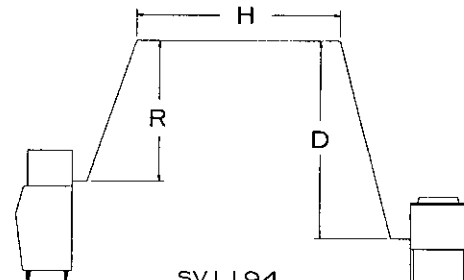

Combination of Rise & Drop  
with Horizontal

## Lengthening or Reducing Line Set Lengths

In most cases, by routing the line set properly, shortening will not be necessary. When shortening or lengthening is required, do so before connecting the line set to the Ice Machine or the remote condenser. This prevents the loss of refrigerant in the Ice Machine or the condenser.

The quick connect fittings on the line sets are equipped with Schrader valves. Use these valves to recover any vapor charge from the line set. When lengthening or shortening lines, apply good refrigeration practices and insulate new tubing. Do not change the tube sizes. Evacuate the lines and place approximately 5 oz (142.86 gm) of vapor refrigerant charge in each line.

### Connection of Line Set:

1. Remove the dust caps from the line set, the condenser, and the Ice Machine.
2. Apply refrigeration oil to the threads on the quick disconnect couplers before connecting them to the condenser.
3. Carefully thread the female fitting to the condenser or Ice Machine by hand.
4. Using the proper size wrench, tighten the couplings until they bottom out. Turn an additional 1/4 turn to ensure proper brass-to-brass seating. If a torque wrench is used torque to the following specifications: liquid line: 10-12 ft lbs ( Nm); discharge line: 35-45 ft lbs ( Nm).
5. Check all fittings for leaks.

**Caution:** If it is necessary to remove the connecting couplers from the Ice Machine or remote condenser, remove all refrigerant from the Ice Machine before attempting to remove the couplers.

## Receiver Service Valve

The receiver service valve is closed during shipment. Open the valve prior to starting the Ice Machine.

1. Remove the top panel and the left side panel.
2. Remove the receiver service valve cap.
3. Backseat (open) the valve.
4. Reinstall the cap and panels.

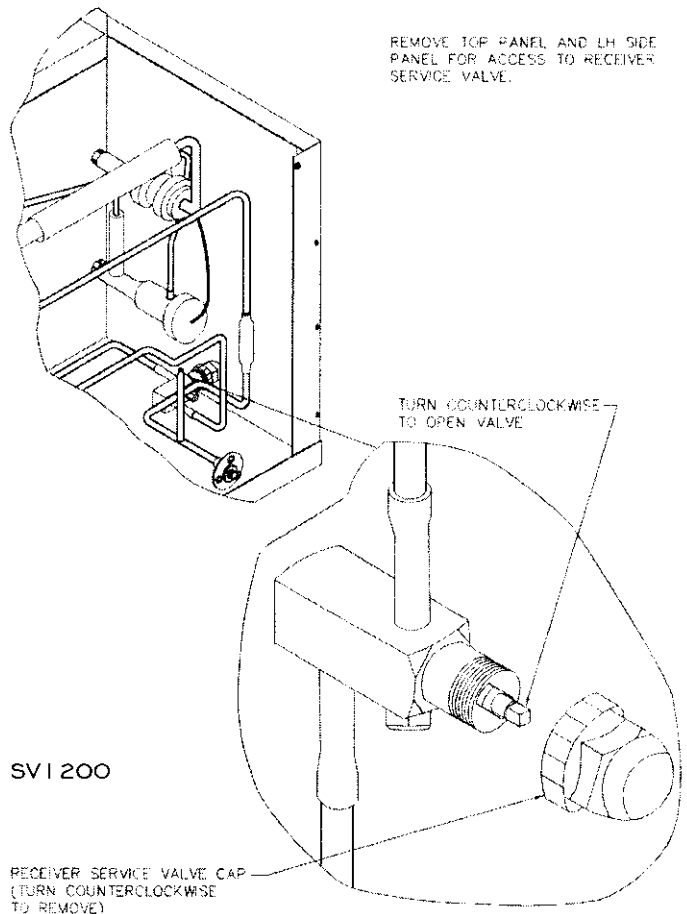

## Backseating Receiver Service Valve

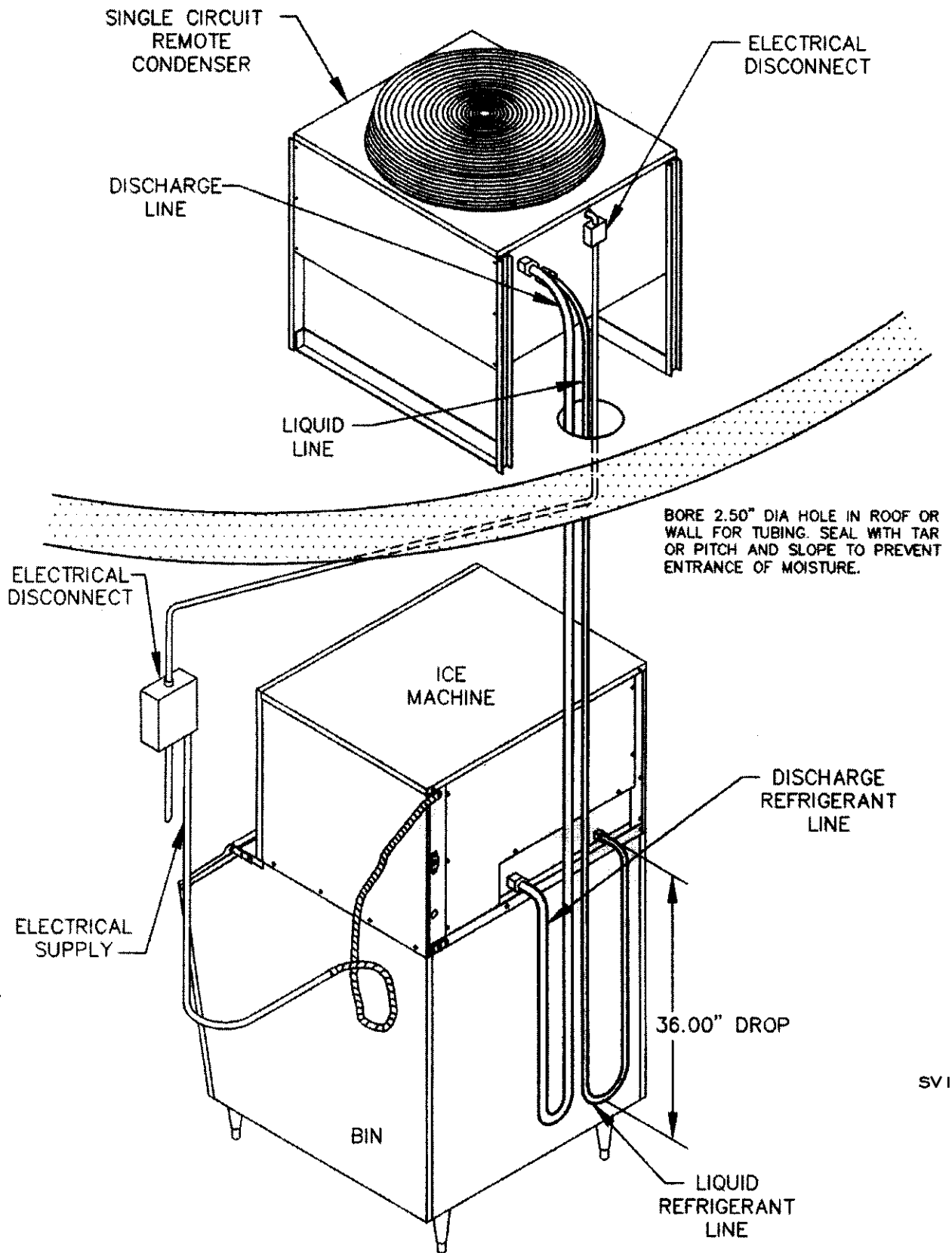

SV1184

**Typical Single Circuit Remote Condenser Installation**

## Installation Checklist

- Is the Ice Machine level?
- Has all the internal packing been removed?
- Have all the electrical and water connections been completed?
- Has the supply voltage been tested and checked against the rating on the nameplate?
- Is there proper clearance around the Ice Machine for air circulation?
- Has the air baffle been installed on air-cooled models?
- Is the Ice Machine installed where ambient temperatures will not vary below 35° F (1.7° C) or above 110° F (43.3° C). Incoming water temperature range 33° F (0.6° C) to 90° F (32.2° C). (See Use and Care Guide, Page 3-14 for Winterizing.)
- Is there a separate drain for the water-cooled condenser?
- Are there Ice Machine and bin drains vented?
- Are all electrical leads free from contact with refrigeration lines and moving components?
- Has the owner/operator been instructed regarding maintenance procedures and the use of Manitowoc Cleaner and Sanitizer?
- Has the owner/operator completed the warranty registration card?
- Has the bin and Ice Machine sanitized?

## Additional Checks for Remote Models

- Has the receiver service valve been opened?
- Does the remote condenser fan operate properly after start-up?
- Is the remote condenser located where ambient temperatures will not vary below 20°F (-28.9°C) or above +130°F (54.4° C).

## Before Starting Ice Machine

All Manitowoc Ice Machines are factory operated and adjusted before shipment. Normally, new installations do not require any adjustment.

To ensure proper operation, follow the OPERATIONAL CHECKS in the Use and Care Guide, Page 3-3 of this manual. Starting the Ice Machine and completing the OPERATIONAL CHECKS is the responsibility of the Owner/Operator. Adjustments and maintenance procedures outlined in the Use and Care section are not covered by warranty.

## AuCS™ Automatic Cleaning System

This optional accessory monitors ice making cycles and initiates self cleaning procedures automatically. The AuCS™ Accessory can be set to automatically clean or sanitize the Ice Machine every 2, 4 or 12 weeks. Refer to the AuCS™ Installation & Owner/Operator Use and Care Guide for details.

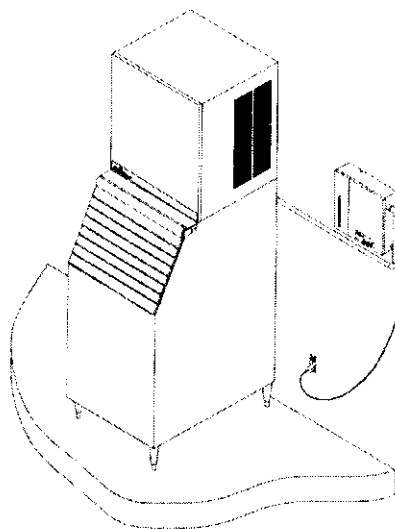

SVI 274

**AuCS™ Automatic Cleaning System**



# Use and Care Guide

## Basic Components and Operation

SVI 206

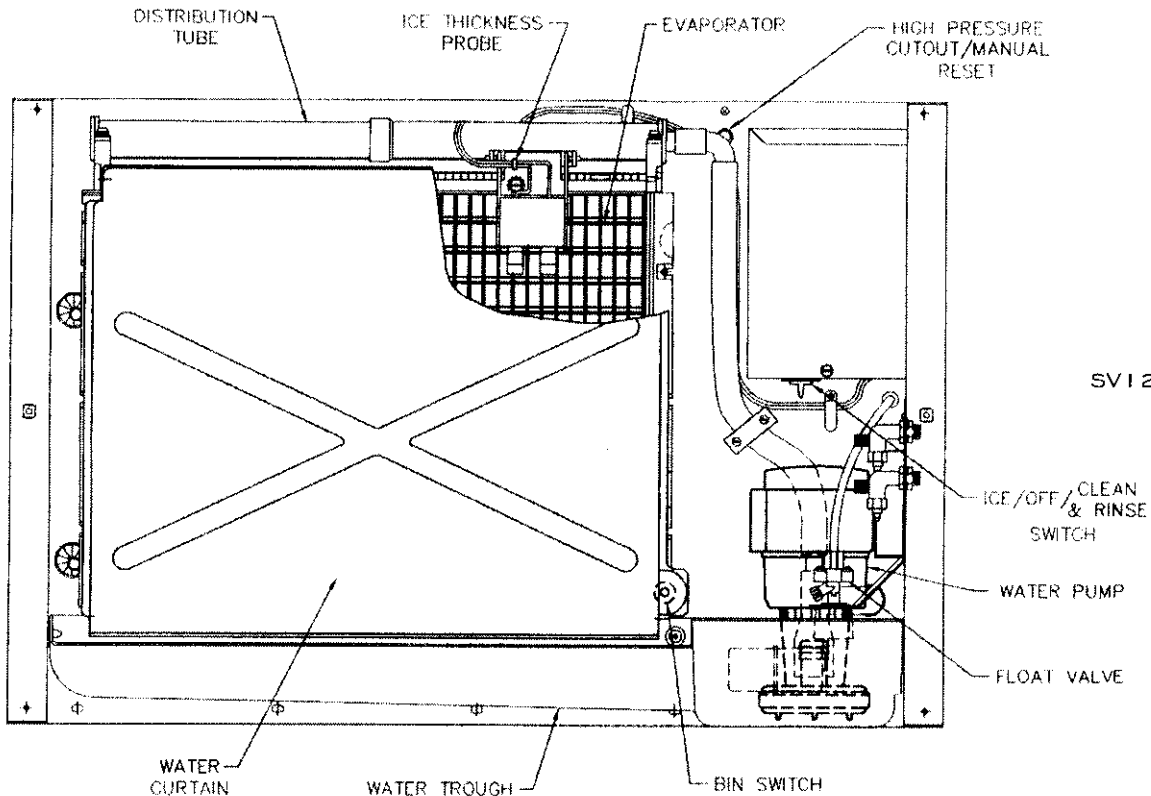
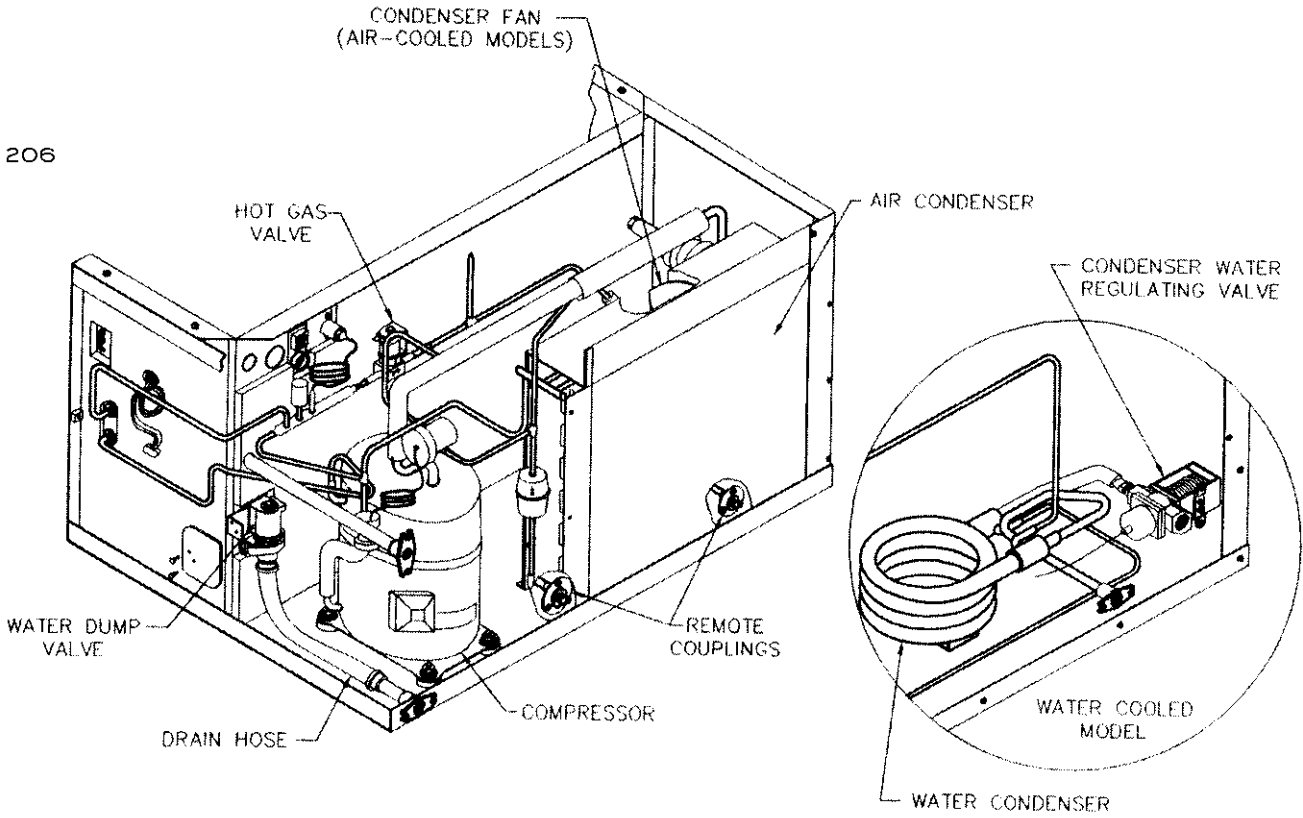

SVI 205

### Component Identification

Typical J450 Shown

## Ice Making - Sequence of Operation

### Initial Start-Up or After Automatic Shut-Off

1. Place the toggle in the ice making position. Before the Ice Machine starts, the water pump and water dump solenoid are energized for 45 seconds to completely purge the sump trough of old water. This feature ensures that the ice making cycle starts with fresh water. During water purge, the hot gas valve is also energized for 50 seconds to assist refrigeration system start-up.

2. The compressor and fan motor of air-cooled and remote models start after the water pump and water dump valve de-energize.

### Freeze Sequence

3. The water pump restarts after a 30 second delay. When the water pump is running, an even flow of water is directed across the evaporator and into each cube cell, where it freezes.

4. When sufficient ice has formed, the water flow contacts the ice thickness probe. After approximately seven (7) seconds, the harvest sequence is initiated.

### Harvest Sequence

5. The hot gas valve opens, diverting hot refrigerant gas into the evaporator, and the water dump solenoid is energized for 45 seconds to purge the water in the sump trough. After the 45 second purge, the water pump and water dump valve de-energize.

6. The hot refrigerant gas warms the evaporator, causing the cubes to slide, as a unit, off the evaporator and into the storage bin. The sliding sheet of cubes swings the water curtain out, activating the bin switch. The momentary opening of the bin switch terminates the harvest sequence and returns the Ice Machine to the freeze sequence ( Steps 3-4).

### Automatic Shut-Off

7. When the storage bin is full, the sheet of cubes fail to clear the water curtain and hold it open. After the water curtain is held open for more than seven seconds, the Ice Machine shuts off. The Ice Machine remains off for a minimum of 3 minutes before it can restart.

8. The Ice Machine remains off until enough ice has been removed from the storage bin that the ice can drop clear of the water curtain. As the water curtain swings back to operating position, the Ice Machine restarts, ( Steps 1-2)provided the 3 minute delay period is complete.

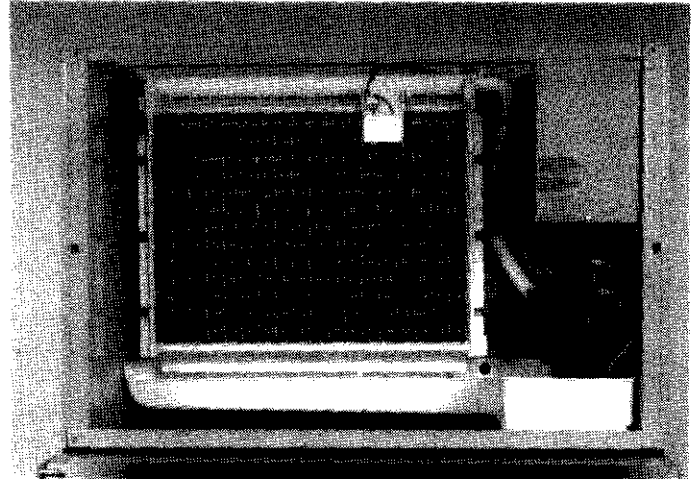

**Freeze Sequence**

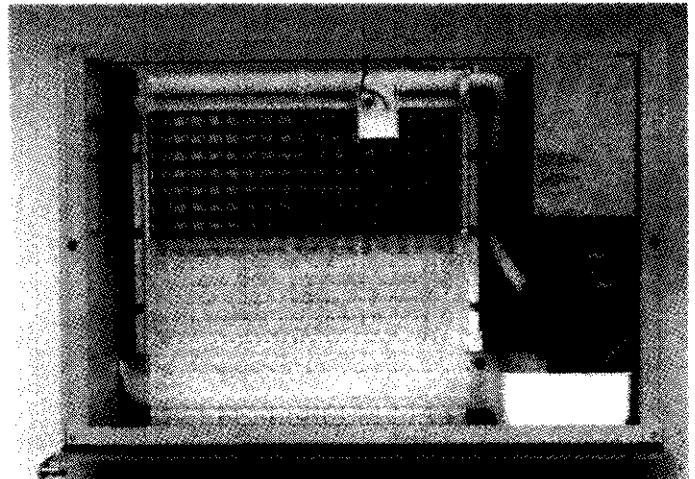

**Harvest Sequence**

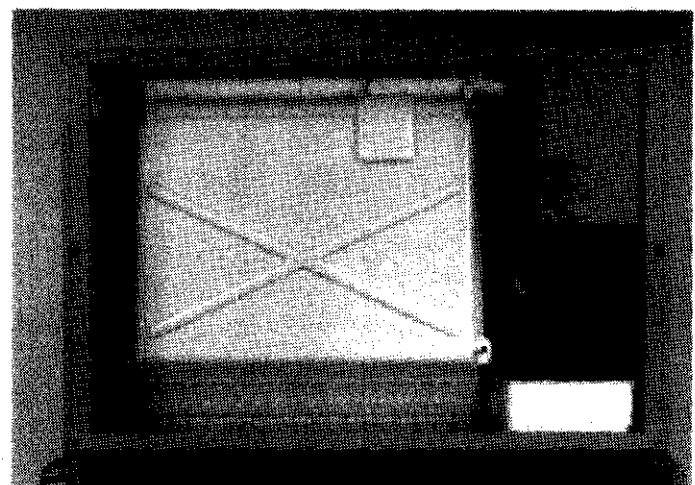

**Automatic Shut-Off**

## Operational Checks

Your Manitowoc Ice Machine is factory operated and adjusted before shipment. Normally, new installations do not require any adjustment. To ensure proper operation, always follow the Operational Checks when starting the Ice Machine for the first time, after a prolonged out of service period, and after cleaning and sanitizing.

Routine adjustments and maintenance procedures outlined in this guide are not covered by the warranty.

### Water Level Check

1. Check the water level while the machine is in the freeze mode and the water pump is running.

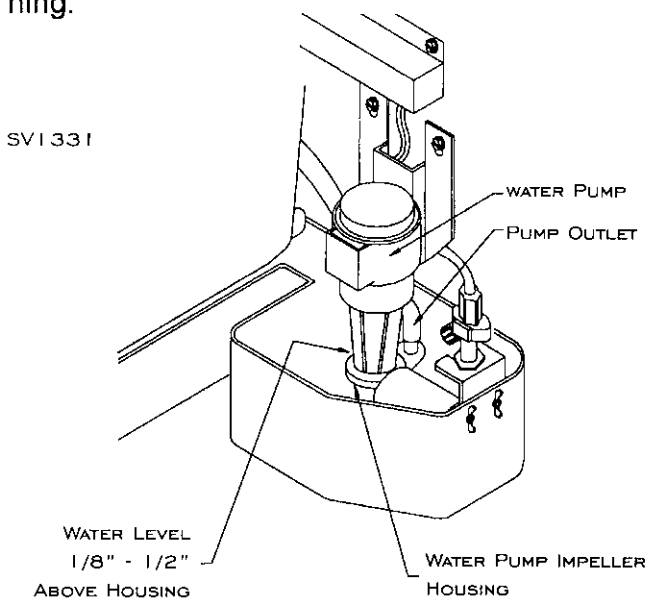

### Water Level Check

2. The water level is correct when it is 1/8" to 1/2" (0.125 - 0.5 in) (3.175 - 2.7 mm) above the water pump impeller housing. The float valve is factory set for the proper water level. Make the following adjustments if necessary:

- Loosen the two screws on the float valve bracket.
- Raise or lower the float valve assembly as needed, then re-tighten the screws.
- If further adjustment is necessary, carefully bend the float arm to achieve the correct water level.

### Ice Thickness Check

The ice thickness probe is factory set to maintain the ice bridge thickness at 1/8" (0.125 in) (3.175 mm).

Make sure the water curtain is in place when performing the ice thickness check. The water curtain prevents water from splashing out of the water trough.

Inspect the bridge connecting the cubes. The bridge should be approximately 1/8" (0.125 in) (3.175 mm) thick. Follow the Steps below if any adjustment is needed.

1. Turn the ice thickness probe adjustment screw clockwise to increase the bridge thickness, or counterclockwise to decrease the bridge thickness.

**Note:** A 1/3 turn of the adjustment screw changes the ice thickness approximately 1/16" (0.0625 in) (1.59 mm).

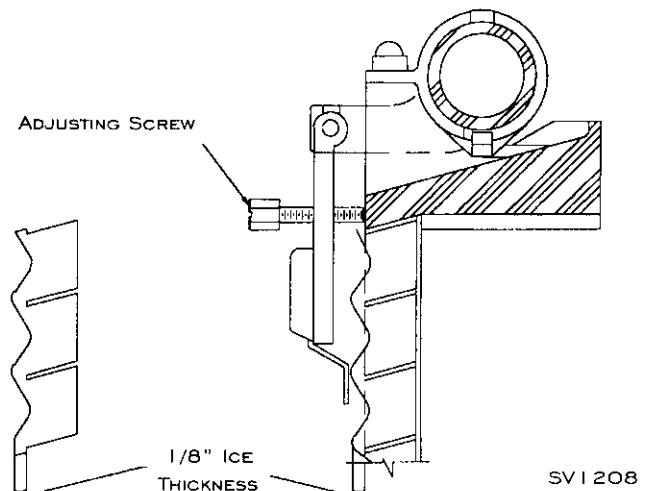

### Ice Thickness Check

2. Make sure the ice thickness probe wires and bracket do not restrict movement of the probe.

## MAINTENANCE

Following a general maintenance schedule ensures reliable, trouble-free operation and maximum ice production.

The warranty does not cover maintenance. You are responsible for maintaining the Ice Machine in accordance with the instructions in this manual. Call your local qualified Manitowoc Service Representative to perform the maintenance if at any time you are either unsure or unaware of

the proper procedures and safety precautions that must be followed.

We recommend that you follow the maintenance guidelines on a semi-annual basis. Record the date you perform the maintenance procedures in the space provided. You can refer to the dates later to remind you to perform the maintenance procedures again.

### Maintenance Guidelines Chart

Semi-Annual Maintenance	Page Reference	Dates of Maintenance
1. General Ice Machine Inspection	3-4	
2. Exterior Cleaning	3-4	
3. Cleaning the Condenser- Air-Cooled Water-Cooled	3-5	
4. Interior Cleaning - SeCS™ Self Cleaning System Cleaning Procedures Sanitizing Procedures Removal of Parts for Cleaning/Sanitizing	3-6	
5. Manitowoc Tri-Liminator Water Filter System	3-13	
6. Operational Checks Water Level Ice Thickness	3-3	
7. Winterization	3-14	

#### General Ice Machine Inspection

Do not stack anything (boxes, etc.) on or around the Ice Machine. Do not cover the Ice Machine while it is operating. There must be adequate air flow through and around the Ice Machine to ensure long component life and maximize ice production.

Check all water fittings and lines for leaks.

#### Exterior Cleaning

1. Clean the area around the Ice Machine as often as necessary to maintain cleanliness and efficient operation.

2. Sponge any dust and dirt off the outside of the Ice Machine with mild soap and water. Wipe dry with a soft clean cloth.

**Caution:** Stainless steel panels should be cleaned with a mild soap or a commercial stainless steel cleanser. Do not use cleansers containing bleaching agents. They usually contain chlorine which stains stainless steel.

Heavy stains should be removed with stainless steel wool. Never use plain steel wool or abrasive pads. They will scratch the panels and cause rusting.

## Cleaning the Condenser

**WARNING:** Disconnect the electric power to the Ice Machine and the remote condenser at the electric service switch before cleaning the condenser!

### Air-Cooled Condenser - Self-Contained And Remote Models

A dirty condenser restricts airflow, resulting in excessively high operating temperatures. This reduces ice production and shortens component life. Clean the condenser at least every six months.

**Caution:** The condenser fins are sharp. Use care when cleaning them.

1. The washable aluminum filter on self-contained Ice Machines is designed to catch dust, dirt, lint, and grease. This helps keep the condenser clean. Clean the filter with a mild soap and water solution.

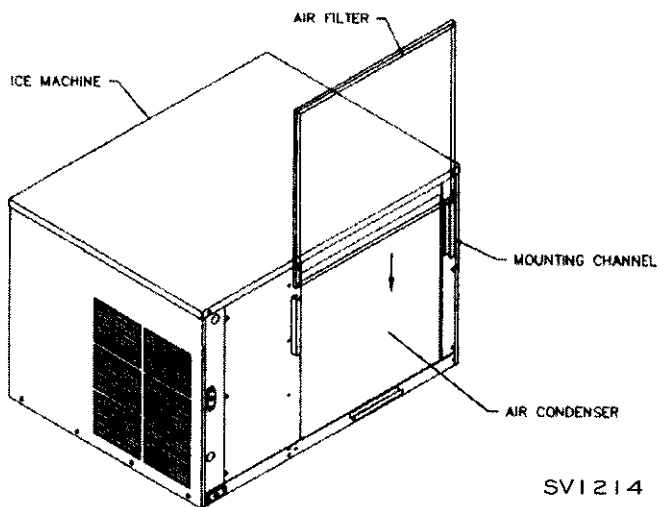

### Self-Contained Air-Cooled Filter

2. Clean the outside of the condenser (the bottom side of the remote condenser) with a soft brush or a vacuum with a brush attachment. Brush or wash the condenser from top to bottom - not from side to side. Be careful not to bend the fins. Shine a flashlight through the condenser to check for dirt between the fins.

If further cleaning is required, use one or both of the following procedures:

- a. Blow compressed air through the condenser from the inside. Take care not to bend the fan blades. Shine a flashlight through the condenser to check that all the dirt is removed.
- b. Clean with a commercial condenser coil cleaner, according to the directions and cautions supplied with the cleaner.

3. Straighten any bent condenser fins with a fin comb.

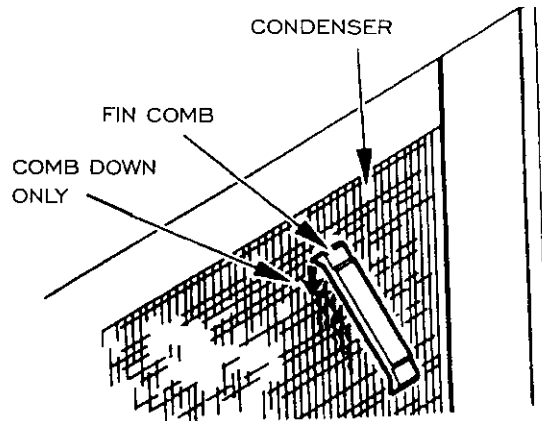

### Straighten Bent Condenser Fins

4. Carefully wipe off the fan blades and motor with a soft cloth, taking care not to bend the fan blades. Wash excessively dirty fan blades with warm soapy water, then rinse thoroughly.

**Caution:** If you are cleaning the condenser fan blades with water, cover the fan motor to prevent water damage.

### Water-Cooled Condenser/ Water Regulating Valve

The water-cooled condenser and water regulating valve may require cleaning due to scale build-up.

Low ice production, high water consumption and high operating temperatures and pressures all may be symptoms of restrictions in the condenser water circuit.

The cleaning procedures require special pumps and cleaning solutions. Therefore they must be performed by qualified maintenance or service personnel.

## INTERIOR CLEANING AND SANITIZING

### General

Clean and sanitize the ice machine every six months for efficient operation. If the ice machine requires more frequent cleaning and sanitizing, consult a qualified service company to test the water quality and recommend appropriate water treatment or installation of AuCS™ accessory (Automatic Cleaning System). If required, an extremely dirty ice machine may be taken apart for cleaning and sanitizing.

**WARNING:** Use only Manitowoc approved Ice Machine Cleaner (part number 94-0546-3) and Sanitizer (part number 94-0565-3). It is a violation of Federal law to use these solutions in a manner inconsistent with their labeling. Read and understand all labels printed on bottles before use.

**CAUTION:** Do not mix Cleaner and Sanitizer solutions together. It is a violation of Federal law to use these products in a manner inconsistent with their labeling.

**WARNING:** Wear rubber gloves and safety goggles (and/or face shield) when handling ice machine cleaner or sanitizer.

### Cleaning Procedures

Ice machine cleaner is used to remove lime scale or other mineral deposits. It is not used to remove algae or slime. Refer to the section on Sanitizing for removal of algae and slime.

**Step 1.** Set the toggle switch to the OFF position after ice falls from the evaporator at the end of a Harvest cycle. Or, set the switch to OFF position and allow the ice to melt off the evaporator. **Never use anything to force ice from the evaporator. Damage may result.**

**Step 2.** To start self-cleaning, place the toggle switch in the CLEAN position. The water will flow through the water dump valve and down the drain.

**Step 3.** Wait about one minute or until water starts to flow over the evaporator.

**Step 4.** Add the proper amount of Manitowoc Ice Machine Cleaner to the water trough.

Ice Machine	Cleaner to be added
J200 J250 J320 J420 J450 J600 J800 J1000	2 ounces
J1300 J1800	4 ounces

**Step 5** The ice machine will automatically time out a ten minute cleaning cycle, followed by six rinse cycles, and then stop. This entire cycle lasts approximately 25 minutes.

**Step 6** When the self-cleaning stops, move the toggle switch to OFF position. Refer to sanitizing procedures on page 3-7.

### Step 7

- A. The ice machine may be set to start and finish a self-cleaning procedure then automatically start ice making again.
- B. You must wait about one minute into the cleaning cycle (until water starts to flow over the evaporator) then move the switch from CLEAN to ICE position.
- C. When the self-cleaning cycle is completed, an ice making sequence will start automatically.

**NOTE:** After the toggle switch is placed in the ICE position, opening the curtain switch will interrupt the cleaning sequence. The sequence will resume from the point of interruption when the curtain re-closes.

## SANITIZING PROCEDURES

Use Sanitizer to remove algae or slime. Do not use it to remove lime scale or other mineral deposits.

**Step 1.** Set the toggle switch to the OFF position after ice falls from the evaporator at the end of a Harvest cycle. Or, set the switch to OFF position and allow the ice to melt off the evaporator. **Never use anything to force ice from the evaporator. Damage may result.**

**Step 2.** To start self-sanitizing, place the toggle switch in the CLEAN position. The water will flow through the water dump valve and down the drain.

**Step 3.** Wait about one minute or until water starts to flow over the evaporator.

**Step 4.** Add the proper amount of Manitowoc Ice Machine Sanitizer to the water trough.

Ice Machine	Sanitizer to be added
J200 J250 J320 J420 J450 J600 J800 J1000	3 ounces
J1300 J1800	6 ounces

**Step 5.** The ice machine will automatically time out a ten minute sanitizing cycle, followed by six rinse cycles, and then stop. This entire cycle lasts approximately 25 minutes.

If the bin requires sanitizing, remove all the ice and sanitize it with a solution of one ounce of sanitizer with up to 4 gallons of water.

**Step 6.** When the self-sanitizing stops, move the toggle switch to ICE position to start ice making again.

### Step 7.

**A.** The ice machine may be set to start and finish a self-sanitizing procedure then automatically start ice making again.

- B.** You must wait about one minute into the sanitizing cycle (until water starts to flow over the evaporator) then move the switch from CLEAN to ICE position.
- C.** When the self-sanitizing cycle is completed, an ice making sequence will start automatically.

**NOTE:** After the toggle switch is placed in the ICE position, opening the curtain switch will interrupt the sanitizing sequence. The sequence will resume from the point of interruption when the curtain re-closes.

## PROCEDURES TO CANCEL A SELF-CLEANING OR SANITIZING CYCLE AFTER IT HAS STARTED

### If less than 45 seconds into cycle:

Move the toggle switch to the OFF position. The cycle is now canceled.

### If more than 45 seconds into cycle:

**Step 1.** Move toggle switch to OFF position.

**Step 2.** Move toggle switch to ICE position.

**Step 3.** Move toggle switch to OFF position.

The cycle is now canceled.

## **AUTOMATIC CLEANING SYSTEM (AuCS™) ACCESSORY**

This accessory monitors ice making cycles and initiates self-cleaning (or sanitizing) procedures automatically. The AuCS™ Accessory can be set to automatically clean or sanitize the ice machine every 2, 4 or 12 weeks.

**DANGER:** Refer to the AuCS™ Accessory Installation-Use and Care Guide for complete details on the installation, operation, maintenance and cautionary statements of this accessory.

### **AUTOMATIC OPERATION**

The following occurs when the toggle switch is in the Ice making position:

- The ice machine control board counts the number of ice harvest cycles.
- The AuCS™ accessory interrupts the ice making mode and starts the automatic cleaning (or sanitizing) mode when the harvest count equals the "frequency of cleaning" setting of the AuCS™.
- When the automatic cleaning (or sanitizing) cycle is complete (approximately 25 minutes), ice making resumes automatically.
- The "harvest count" is reset to zero after the AuCS™ cycle is completed.

**NOTE:** Opening the curtain switch will interrupt the cleaning or sanitizing sequence. The sequence will resume from the point of interruption when the curtain re-closes.

### **MANUAL START OPERATION**

**Step 1.** Set the toggle switch to the OFF position after ice falls from the evaporator at the end of a Harvest cycle. Or, set the switch to OFF position and allow the ice to melt off the evaporator. **Never use anything to force ice from the evaporator. Damage may result.**

**Step 2.** To start the Automatic Cleaning System (AuCS), place the toggle switch in the CLEAN position. The water will flow through the water dump valve and down the drain. The AuCS will then automatically add cleaner or sanitizer to the ice machine.

**Step 3.** The ice machine will automatically time out a ten minute cleaning (or sanitizing) cycle, followed by six rinse cycles, and then stop. This entire cycle lasts approximately 25 minutes.

**Step 4.** After the cleaning (sanitizing) cycle stops, move the toggle switch to ICE position.

#### **Step 5.**

- A. The ice machine may be set to start and finish a self-cleaning or sanitizing procedure then automatically start ice making again.
- B. You must wait about one minute into the cleaning cycle (until water starts to flow over the evaporator) then move the switch from CLEAN to ICE position.
- C. When the self-cleaning cycle is completed, an ice making sequence will start automatically.

## Removal of Parts for Cleaning /Sanitizing

1. Turn off the water supply to the Ice Machine at the water service valve.

**WARNING:** Disconnect electric power to the Ice Machine at the electric switch box before proceeding.

2. Remove the water trough, water curtain, water pump, water distribution tube and ice thickness probe. Refer to the appropriate sections in this Installation & Use and Care Guide.

**WARNING:** Wear rubber gloves, safety goggles, and/or face shield when handling Ice Machine cleaner or sanitizer.

3. Soak the removed parts in a properly mixed solution:

**Manitowoc Cleaner** - mix 16 oz of cleaner with 1 gal of water (457.14 gm to 3.784 L).

**Manitowoc Sanitizer** - mix 1 oz of sanitizer with 4 gal of water (28.57 gm to 15.136 L).

Use a soft-bristle brush or a sponge to clean the parts. **DO NOT USE A WIRE BRUSH.** Take care not to damage the parts.

**Caution:** Do not mix Cleaner and Sanitizer solutions together. It is a violation of Federal law to use these products in a manner inconsistent with their labeling.

**Caution:** Do not immerse the water pump motor in the cleaning or sanitizing solution.

4. Use the cleaning or sanitizing solution and a brush or sponge to clean the top, sides, and bottom evaporator extrusions, the inside of the Ice Machine panels, and the entire inside of the bin.

5. Thoroughly rinse all of the parts and surfaces with clean water and re-install the parts.

**Note:** Incomplete rinsing of the ice bridge thickness probe may leave a residue. This could cause the Ice Machine to go into the harvest cycle prematurely. For best results, brush or wipe the probe off while rinsing. Thoroughly dry it before replacing it.

6. Turn the water and electrical supply back on.

## Water Dump Valve Removal

The water dump valve normally does not require removal for cleaning. Follow the instructions listed below to determine if removal is necessary.

1. Locate the water dump valve in Ice Machine.
2. Set the ICE/OFF/CLEAN switch to ICE.
3. Check the dump valve's clear plastic outlet drain hose, for leakage while the Ice Machine is in the freeze mode. Refer to the Water Pump Removal illustration on Page 3-11.
4. If the dump valve is leaking, remove, disassemble and clean it.
5. Do not remove the dump valve if it is not leaking. Following the SeCS™ Self Cleaning procedures on Page 3-6 is adequate.

### Removal Procedure

**WARNING:** Disconnect the electric power to the Ice Machine at the electric service switch box.

1. If so equipped, remove the water dump valve shield from its mounting bracket.
2. Lift and slide the coil retainer cap from the top of the coil.
3. Leaving the wires attached, lift the coil assembly off of the valve body and the enclosing tube. Note the position of the coil assembly on the valve before removing it. Make sure the coil is in the same position when reassembling the valve.
4. Press the enclosing tube's plastic nut down and rotate it 1/4 turn. Remove the enclosing tube, plunger and plastic gasket from the valve body.

The water dump valve can easily be cleaned at this point, without removing the entire valve body.

You do not need to remove the spring from the plunger when cleaning. If the spring is removed, insert the spring's flared end into the slotted opening in the top of the plunger, until it comes in contact with the plunger spring stop. Do not stretch or damage the spring when cleaning.

**Important:** The plunger and the inside of enclosing tube must be thoroughly dry before reassembling.

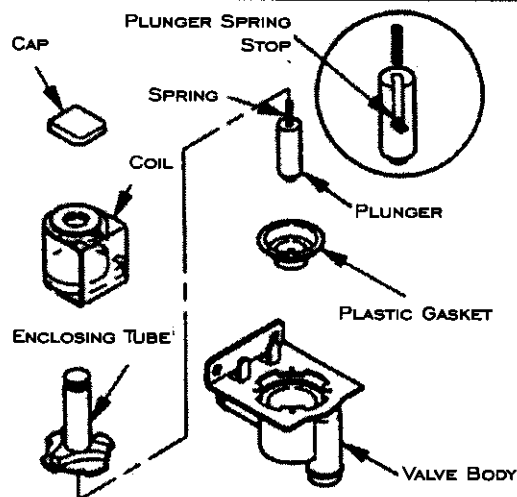

### Dump Valve Disassembly

5. Remove the valve body.
  - a. Remove the tubing from the dump valve by twisting the clamps off.
  - b. Remove the two screws securing the dump valve and the mounting bracket.

**WARNING:** Disconnect the electrical power to the Ice Machine at the electrical switch box and turn off the water supply before proceeding.

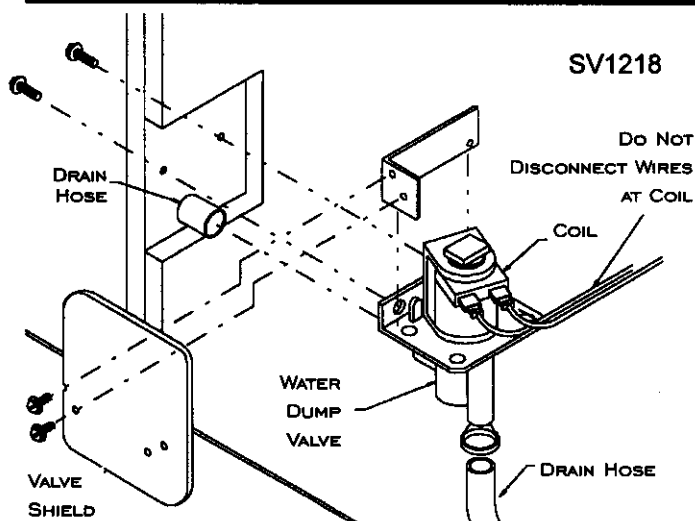

## Water Pump

1. Disconnect the water pump power cord.

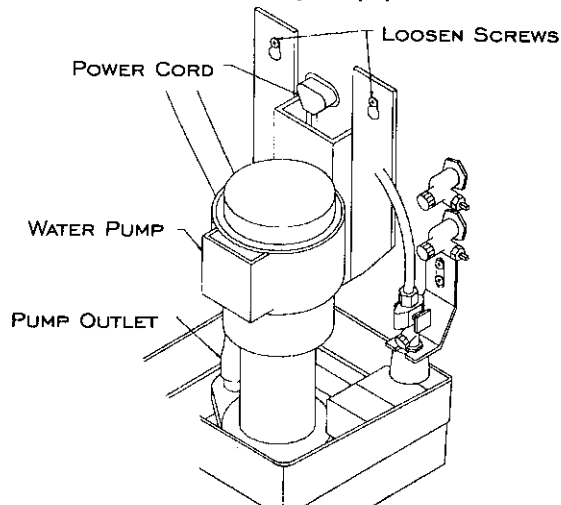

SV1209

### Water Pump Removal

2. Disconnect the hose from the pump outlet.
3. Loosen the two screws which hold the pump mounting bracket to the bulkhead.
4. Lift the pump and bracket assembly off screws.

## Ice Thickness Probe

1. Remove the ice thickness probe by compressing the side of the probe near the top hinge pin and removing it from the bracket.

**Note:** The ice thickness probe can be cleaned at this point without proceeding to Step 2.

**WARNING:** Disconnect the electric power to Ice Machine at the electric service switch box before proceeding.

2. If complete removal is required, disconnect the wire leads from the unitized sensor board inside the electrical control box.

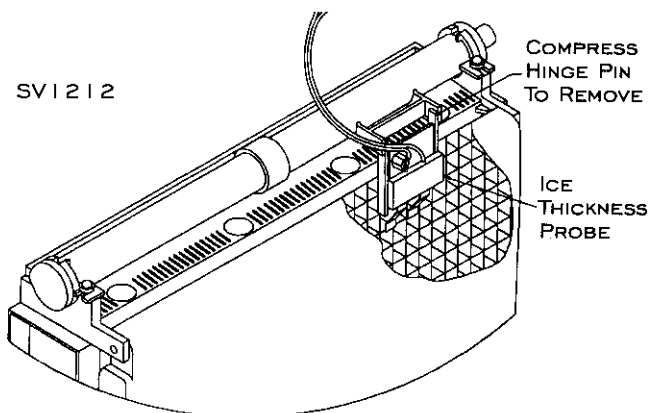

SV1212

### Ice Thickness Probe Removal

## Water Trough

Water trough removal varies slightly by models. The following procedure and illustration are typical:

1. Remove the screws holding the sump trough in place.
2. Lower the right side of the trough into the bin.
3. Disengage the left side of the trough from its holding pegs and remove the trough from the Ice Machine.

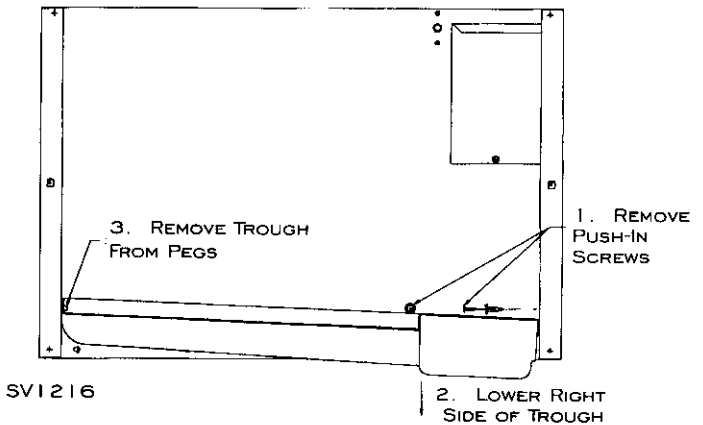

SV1216

### Water Trough Removal

## Float Valve

1. Turn the valve splash shield counter-clockwise one or two turns. Pull the valve forward and off the mounting bracket.
2. Disconnect the water inlet tube from the float valve at the compression fitting.
3. Remove the filter screen and cap for cleaning.

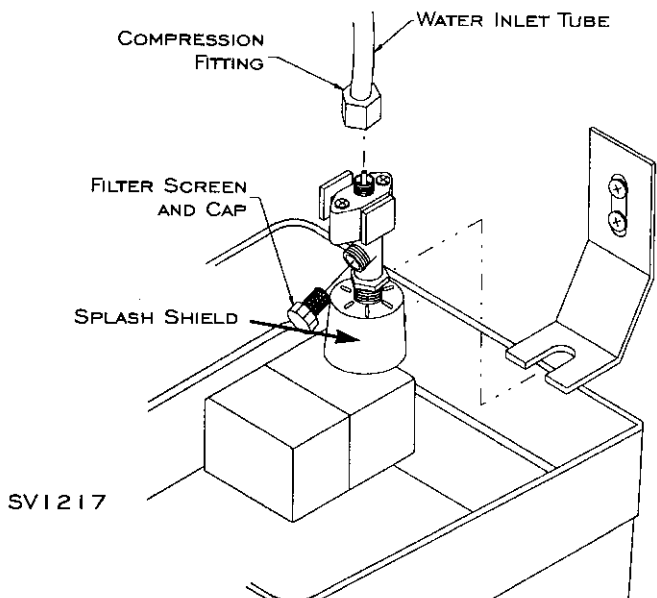

SV1217

### Float Valve Removal

## Water Distribution Tube

1. Disconnect the water hose from the distribution tube.
2. Loosen the two thumbscrews which hold the distribution tube in place.
3. Lift the right side up to clear the locating pin, then slide it back and to the right.

**Important:** Do not force this removal. Be sure the locating pin clears the hole before sliding it out.

1. LIFT UP
2. SLIDE BACK
3. SLIDE TO RIGHT

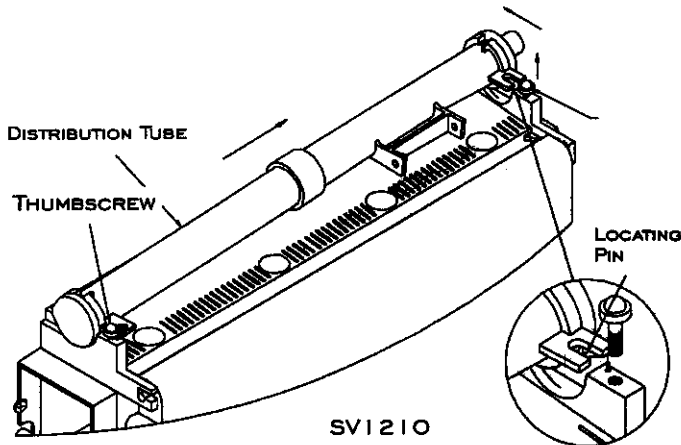

## Water Distribution Tube Removal

4. Disassemble for cleaning.
  - a. Twist both of the inner tube ends until the tabs line up with the keyways.
  - b. Pull the inner tube ends outward.

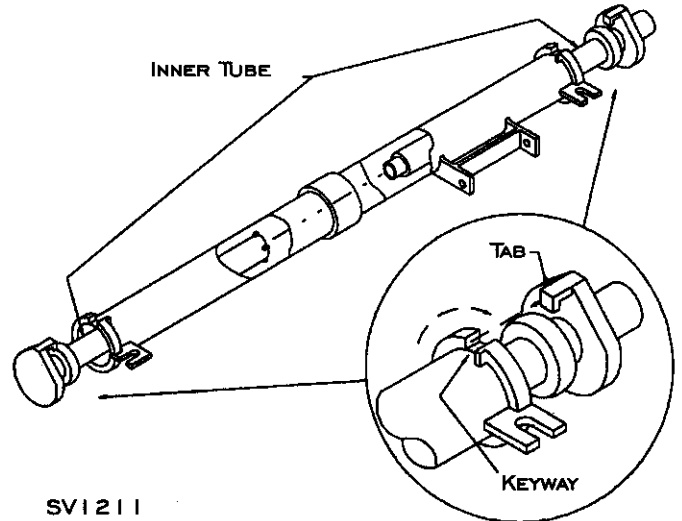

## Water Distribution Tube Disassembly

## Water Curtain

1. Gently flex the curtain in the center and remove it from the right side.
2. Slide the left pin out

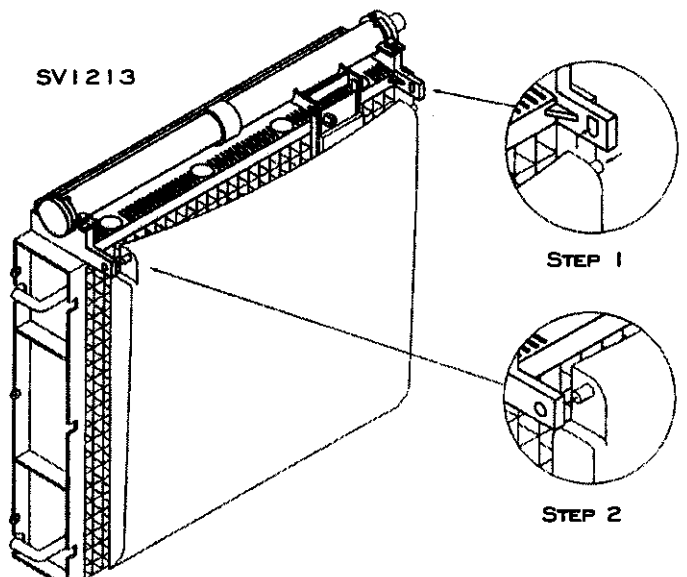

## Water Curtain Removal

## Water Treatment - Filtration

Local water conditions may require the installation of a water treatment system to inhibit scale formation, filter sediment, and remove chlorine taste and odor. Consult your local dealer or distributor for information on Manitowoc's full line of Tri-Liminator filtration systems.

Replace the primary filter cartridge every six months to ensure maximum filtration efficiency. If the filter gauge indicates below 20 psig (6.8343 kg cm<sup>2</sup>), earlier replacement is necessary.

Tri-Liminator systems include a prefilter, and should not require primary filter replacement prior to six months of usage. If replacement is needed, replace the prefilter first.

### Replacement Procedure

1. Turn off the water supply at the inlet shut-off valve.
2. Depress the pressure release button to relieve the pressure.
3. Unscrew the housing from the cap.
4. Remove the used cartridge from the housing and discard it.

5. Remove the O-ring from the groove in the housing. Wipe the groove and O-ring clean. Relubricate the O-ring with a coating of a clean petroleum jelly like Vaseline. Replace the O-ring, and press it down into the groove with two fingers.

6. Insert a new cartridge into the housing. Make sure it slips down over the housing stand-pipe.

7. Screw the housing onto the cap and hand tighten. **DO NOT OVER TIGHTEN. DO NOT USE A SPANNER WRENCH.**

8. Repeat Steps 3 through 7 for each filter housing.

9. Turn on the water supply to allow the housing and filter to slowly fill with water.

10. Depress the pressure release button to release trapped air from the housing. Check for leaks.

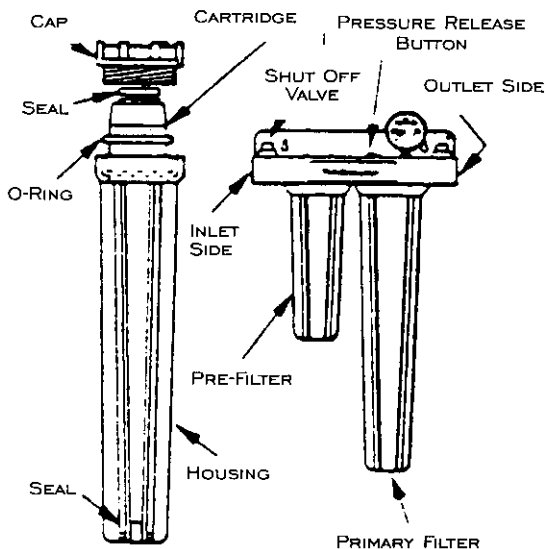

## Water Filtration

## Removal from Service - Winterization

You must take special precautions if the Ice Machine is to be removed from service for extended periods, or exposed to ambient temperatures of 32° F or below.

**Caution:** If water is allowed to remain in the Ice Machine in freezing temperatures, severe damage to some components could result. Damage of this nature is not covered by the warranty.

### Self-Contained Air-Cooled Machines

1. Disconnect the electric power at the circuit breaker or the electric service switch.
2. Turn off the water going to the Ice Machine.
3. Remove the water from the sump trough.
4. Disconnect the incoming ice making water line, and drain the line at the rear of Ice Machine.
5. Blow compressed air in both the incoming water and the drain openings in the rear of the machine until no more water comes out of the float valve and drain.
6. Be sure no water is trapped in any of the machine's water lines, drain lines, distribution tubes, etc.

### Water-Cooled Machines

1. Perform all the procedures listed under Self-Contained Air-Cooled Machines above.
2. Disconnect the incoming water and drain lines from the water-cooled condenser.
3. Pry open the water regulating valve by inserting a large standard screwdriver between the bottom spring coils of the valve. Pry the spring upward to open the valve.
4. Hold the valve open and blow compressed air through the condenser until no water remains.

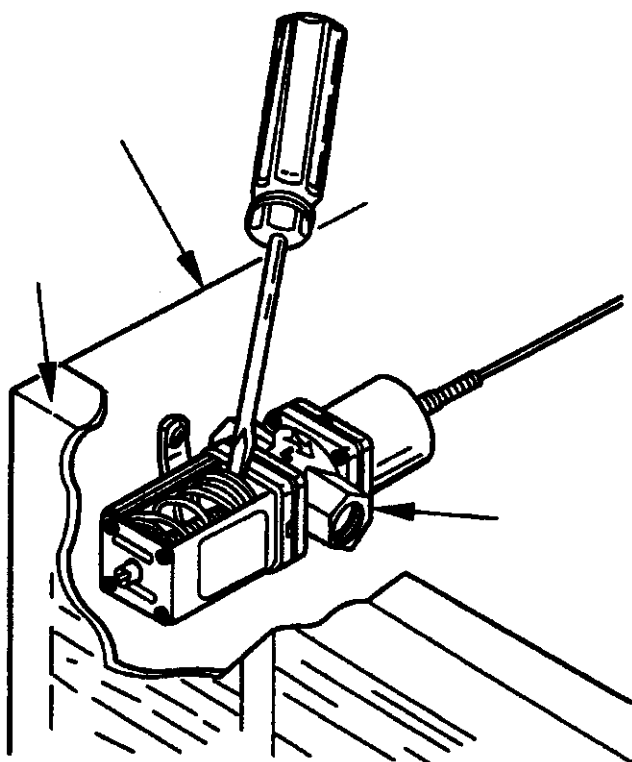

**Manually Open Water Regulating Valve**

### Remote Machines

1. Turn the ICE/OFF/CLEAN switch to OFF.
2. "Frontseat" or shut off the receiver service valves. Hang a tag on the switch as a reminder to open the receiver service valves before restarting.
3. Perform all the procedures listed under Self-Contained Air-Cooled Machines.

### AuCS™ Automatic Cleaning System Accessory

Refer to the AuCS™ Accessory Installation Owner/Operator Use and Care Guide for winterization of AuCS™ Accessory.

## BEFORE CALLING FOR SERVICE CHECKLIST

If a problem arises during the operation of your Ice Machine, follow the checklist below before calling for service. Routine adjustments and maintenance procedures are not covered by warranty.

Problem	Possible Cause	Corrective Action
Ice Machine does not operate.	<p>No electrical power to the Ice Machine.</p> <p>Tripped high pressure cutout.</p> <p>ICE/OFF/CLEAN switch set improperly.</p> <p>Water curtain stuck open.</p> <p>Remote receiver valve closed.</p>	<p>Replace the fuse, reset the circuit breaker, turn on the main switch.</p> <p>Reset the high pressure cutout, Page 3-1.</p> <p>Set the switch at Ice.</p> <p>Water curtain must swing freely, Page 3-12.</p> <p>Open the valve.</p>
Ice Machine stops, and can be restarted by turning the switch off, then on again.	Safety Limit Feature stopping the Ice Machine.	Refer to the Safety Limit Feature at the end of this checklist.
Ice Machine does not release ice or is slow to harvest.	<p>Ice Machine is dirty.</p> <p>Ice Machine is not level.</p> <p>Air-cooled models: low ambient temperature.</p> <p>Water regulating valve is leaking during the Harvest mode (water-cooled machines).</p>	<p>Clean and sanitize the Ice Machine, Page 3-6.</p> <p>Level the Ice Machine.</p> <p>Minimum ambient temperature is 35° F.</p> <p>Refer to the Water-Cooled Condenser section, Page 3-5.</p>
<p>Ice Machine does not cycle into Harvest mode.</p> <p>Note: Ice Machine must be in the freeze cycle for six (6) minutes before a Harvest cycle can be initiated.</p>	<p>Ice thickness probe is dirty.</p> <p>Ice thickness probe wires are disconnected.</p> <p>Ice thickness probe is out of adjustment.</p> <p>Uneven ice fill (thin at top of the evaporator).</p>	<p>Clean and sanitize the Ice Machine, Page 3-6.</p> <p>Connect the wires.</p> <p>Adjust ice thickness probe, Page 3-11.</p> <p>Refer to Shallow or Incomplete cubes, Page 3-16.</p>
Poor quality ice. Ice is soft or not clear.	<p>Quality of the incoming water is poor.</p> <p>Water filtration element needs to be changed.</p> <p>Ice Machine is dirty.</p> <p>Water dump valve is not working.</p> <p>Water softener working improperly (if installed).</p>	<p>Contact a qualified service company to test the quality of the water and make appropriate filter recommendations.</p> <p>Replace the filter.</p> <p>Clean and Sanitize the ice machine, Page 3-6.</p> <p>Disassemble and clean the water dump valve, Page 3-10</p> <p>Repair the water softener.</p>

Problem	Possible Cause	Corrective Action
Shallow or incomplete cubes, incomplete ice fill pattern on the evaporator.	Ice thickness probe is out of adjustment. Water trough level is too high or too low. Water float valve filter screen is dirty. Ice Machine is dirty. Water filtration is poor. Hot incoming water.  Incorrect incoming water pressure. Leaky water dump valve.  Ice Machine is not level.	Adjust the ice thickness probe, Page 3-3. Adjust the float valve, Page 3-3.  Clean the filter screen, Page 3-11.  Replace the filter, Page 3-11. Connect the ice machine to a cold water supply. See the Installation Instructions. Water pressure must be 20-80 psi. Clean the water dump valve, Page 3-10. Level the Ice Machine.
Low ice capacity.	Water float valve filter screen dirty. Float valve shut-off is closed. Incoming water supply shut off. Float valve stuck open. Dirty condenser. High ambient temperature.  Inadequate clearance around the Ice Machine, causing air flow restriction. Object stacked on or around the ice machine, blocking air flow to the condenser (air-cooled models). Air baffle is not installed (air-cooled).	Clean the filter screen, Page 3-11.  Open the shut-off valve, Page 3-11. Open the water service valve. Clean and adjust, Page 3-11. Clean the condenser, Page 3-5. Maximum ambient temperature is 110° F. Provide adequate clearance.  Remove objects.  Install the air baffle.

### SAFETY LIMIT FEATURE

In addition to the standard safety controls, such as the high pressure cutout, your Manitowoc Ice Machine features built-in safety limits which stop the Ice Machine if conditions exist that may result in a major component failure.

Before calling for service, re-start the Ice Machine using the following procedures:

1. Turn the ICE/OFF/CLEAN switch OFF and then back to ICE. If the safety limit feature has stopped the Ice Machine, it will restart after a short delay. Proceed to Step 2.  
If the Ice Machine does not restart, refer to Ice Machine Does Not Operate in the problem checklist.
2. Let the Ice Machine operate to determine if the condition is recurring.  
If the Ice Machine stops again, the condition recurred. Call for service.  
If Ice Machine continues to run, the condition corrected itself. Let the machine run.

**Notes**

---

## ICE MACHINE WARRANTY

Manitowoc Ice, Inc., hereinafter referred to as the COMPANY, warrants new Ice Machines manufactured by the COMPANY to be free from defects in material and workmanship under normal use and service for a period of thirty-six (36) months from the date of original installation, and twenty-four (24) additional months on the evaporators and compressors. The obligation of the COMPANY under this warranty is limited to the repair or replacement of parts or assemblies that in the COMPANY'S opinion are defective F.O.B. the factory.

In addition to the component warranty explained above, the COMPANY will pay straight time labor to repair or replace a defective component when failure occurs within thirty-six (36) months from the date of original installation and twenty-four (24) additional months on evaporator and only when such service is performed by a COMPANY Contracted Service Representative or a refrigeration service agency as qualified and authorized by the COMPANY'S local Distributor.

Time and hourly rate schedules as published from time to time by the COMPANY, apply to all service procedures. Additional expense including, but not limited to, overtime premium, travel time, material cost, accessing or removal of the Ice Machine, is the responsibility of the owner along with all maintenance, adjustments, cleaning and ice purchases.

The foregoing warranty shall not apply to (1) any part or assembly that has been altered, modified, or changed; (2) any part or assembly that has been subject to misuse, abuse, neglect, or accidents; or (3) any Ice Machine that has been installed and/or maintained inconsistent with the technical instructions provided by the COMPANY.

The sixty (60) month compressor warranty, including the thirty-six (36) month labor replacement warranty, shall not apply when the Ice Machine's refrigeration system is modified with a condenser, heat reclaim device, or parts and assemblies other than those manufactured by the COMPANY, unless the COMPANY approves these modifications for specific locations in writing.

**THIS WARRANTY IS IN LIEU OF ALL OTHER WARRANTIES OR GUARANTEES OF ANY KIND, EXPRESSED OR IMPLIED, INCLUDING ANY IMPLIED WARRANTY OF MERCHANTABILITY OR FITNESS FOR A PARTICULAR PURPOSE EXCEPT AS PROVIDED IN THIS WARRANTY WITH RESPECT TO DEFECTS IN MATERIAL AND WORKMANSHIP.** This liability of the COMPANY arising out of the sale, use or operation of the COMPANY'S parts and equipment, whether in warranty, contract negligence or strict liability, including claims for special, indirect or consequential damages, shall not in any event exceed the cost of furnishing replacement for a defective part of assembly as hereinabove provided. Upon the expiration of the warranty period as hereinabove provided, any such liability shall terminate. The foregoing warranty shall constitute the sole exclusive liability of the COMPANY

To secure prompt and continuing warranty service, the warranty registration card must be completed and sent to the COMPANY within five (5) days from the installation date.

Complete the following for your record:

**Distributor/Dealer:** \_\_\_\_\_

**Model Number/Serial Number:** \_\_\_\_\_

**Installation Date:** \_\_\_\_\_

Effective January 1, 1991 in the United States, Canada, and international markets served by Manitowoc.

Revised January 2, 1991



**MANITOWOC ICE, INC.**

2110 South 26th Street

P.O. Box 1720

Manitowoc, WI 54221-1720 U.S.A.

Telephone: 414-682-0161

RCA Telex: 297863 MANCO-UR

FAX: 414-683-7879

We reserve the right to make product improvements at any time.  
Specifications are subject to change without notice.

© 1996 all rights reserved