

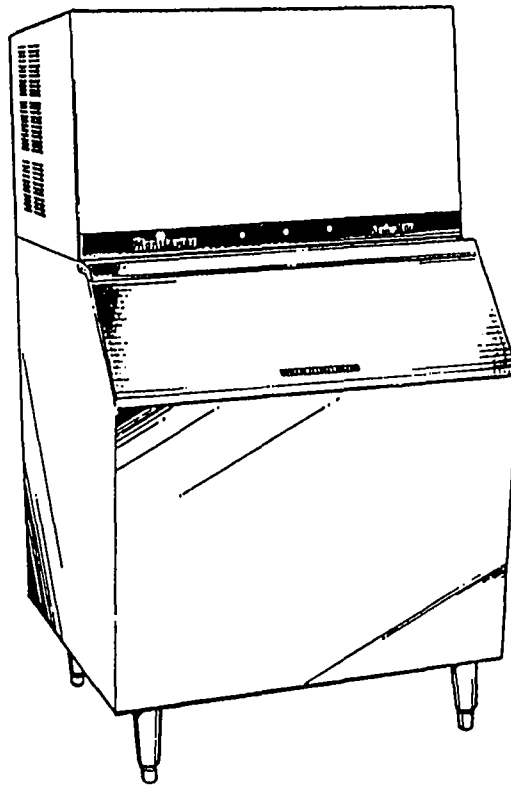


# Manitowoc<sup>®</sup>

## ICE MACHINES

**Series  
G400**

### SERVICE MANUAL



G6SVCVR

This product qualifies for the following listings:



We reserve the right to make product improvements at any time. Specifications and design are subject to change without notice.



Part No. 80-0843-3  
Rev 1 (8-92)



# TABLE OF CONTENTS

<b>GENERAL SPECIFICATIONS</b> . . . . .	1
<b>WARRANTY INFORMATION</b> . . . . .	2
<b>DIMENSIONS</b> . . . . .	4
<b>COMPONENT IDENTIFICATION</b> . . . . .	8
Water Distribution Group and Outer Panels . . . . .	8
Control Box Assemblies . . . . .	9
Compressor Compartment (Air-Cooled) . . . . .	10
Compressor Compartment (Water-Cooled) . . . . .	11
Compressor Compartment (Remote Condenser) . . . . .	12
<b>INTERIOR CLEANING</b> . . . . .	13
Removal of Parts for Cleaning . . . . .	13
Remove Water Pump . . . . .	13
Remove Float Valve . . . . .	14
Remove Distribution Tube . . . . .	14
Disassemble Distribution Tube . . . . .	14
Remove Ice Thickness Probe . . . . .	15
Remove Water Trough . . . . .	15
Cleaning Procedures . . . . .	15
Cleaning the Evaporator Surface . . . . .	16
<b>SANITIZING</b> . . . . .	17
<b>CHECKING AND CLEANING THE WATER DUMP VALVE</b> . . . . .	17
Operation Check . . . . .	17
Remove Water Dump Valve . . . . .	18
Disassemble Water Dump Valve . . . . .	18
Cleaning Water Dump Valve . . . . .	18
<b>ELECTRICAL SYSTEM SEQUENCE OF OPERATION, SELF-CONTAINED</b>	
<b>AIR AND WATER COOLED</b> . . . . .	19
Freeze Cycle (Prechill of Evaporator) . . . . .	19
Freeze Cycle . . . . .	21
Harvest Cycle . . . . .	23
Automatic Shut-Off (Full Bin of Ice) . . . . .	25
<b>ELECTRICAL SYSTEM SEQUENCE OF OPERATION, REMOTE ICE MACHINES</b> . . . . .	26
Freeze Cycle (Prechill of Evaporator) . . . . .	26
Freeze Cycle . . . . .	28
Harvest Cycle . . . . .	30
Automatic Shut-Off (Full Bin of Ice) . . . . .	32
Auto Restart . . . . .	32
Automatic Shut-Off (Refrigeration Sequence) . . . . .	33
Automatic Shut-Off Water Flow Sequence . . . . .	33
<b>SERVICE DIAGNOSTIC CHART</b> . . . . .	34

<b>COMPONENT FUNCTION, SPECIFICATIONS AND CHECK PROCEDURES</b> . . . . .	36
Bin Switch . . . . .	36
Fan Cycle Control (Self-Contained Air-Cooled Models) . . . . .	36
Float Valve . . . . .	37
High Pressure Cut-Out Control — H.P.C.O. . . . .	37
Ice Thickness Probe . . . . .	38
ICE/OFF/WATER PUMP Toggle Switch . . . . .	38
Water Curtain . . . . .	39
Water Pump . . . . .	39
Water Pump Delay Timer . . . . .	40
7-Second Off Delay Relay (Self-Contained Air or Water Cooled) . . . . .	41
Low Pressure Cut-Out Control (Remote Machines) . . . . .	42
Harvest Pressure Limiter Switch . . . . .	42
<b>DIAGNOSING ELECTRONIC CONTROL CIRCUITRY</b> . . . . .	43
Unitized Sensor Board . . . . .	43
Ice Machine Will Not Go Into Harvest . . . . .	43
Ice Machine Prematurely Goes Into Harvest without Ice Formation . . . . .	44
<b>DIAGNOSING COMPRESSOR AND START COMPONENTS ELECTRICALLY</b> . . . . .	45
<b>REFRIGERATION AND OTHER NON-ELECTRICAL PROBLEMS</b> . . . . .	47
Introduction to the Six-Step Diagnostic Procedure . . . . .	47
Step 1 — Visual Inspection . . . . .	48
Step 2 — Ice Production . . . . .	49
Step 3 — Ice Fill Pattern . . . . .	50
Step 4 — Water System . . . . .	50
Step 5 — Refrigeration . . . . .	51
Step 6 — Final Analysis . . . . .	57
Headmaster Control Valve (Remote Machines) . . . . .	59
<b>HOW TO USE MANIFOLD GAUGES</b> . . . . .	60
<b>TXV INSTALLATION</b> . . . . .	61
<b>ALCO REFRIGERATION SOLENOID VALVE REPLACEMENTS</b> . . . . .	62
<b>LEAK CHECKING CONDENSER AND WATER REGULATING VALVE</b> . . . . .	63
<b>REMOVAL FROM SERVICE/WINTERIZATION</b> . . . . .	64
<b>EVACUATION AND RECHARGING</b> . . . . .	65
<b>SEVERE SYSTEM CONTAMINATION</b> . . . . .	69
General . . . . .	69
Determining Severity of Contamination and Clean-Up Procedures . . . . .	69
Mild System Contamination Clean-Up Procedures . . . . .	70
Severe System Contamination Clean-Up Procedures . . . . .	70

**MANITOWOC ICE, INC.**

2110 South 26th Street P.O. Box 1720 Manitowoc, WI 54221-1720

Phone: (920) 682-0161

Fax: (920) 683-7585

Web Site: [www.manitowocice.com](http://www.manitowocice.com)

# GENERAL SPECIFICATIONS

This section is not intended to be a guideline to install the ice machine. Refer to Installation Manual for installation procedures.

**Ambient Air Temperature:** 35°F minimum, 110°F maximum (minimum five-inch clearance rear and sides)

**Ice Making Water Supply:**

Pressure — 20 psig minimum, 80 psig maximum  
 Supply Line — 3/8 inch FPT  
 Drain Line — 3/4 inch FPT  
 Water Temperature — 35°F minimum, 90°F maximum

**Water-Cooled Condenser Water Supply:**

Water Regulating Valve Setting — 240 psig ± 5 (Factory preset)  
 Pressure — 20 psig minimum, 150 psig maximum  
 Supply Line — 1/2 inch up to the 3/8" FPT connection  
 Drain Line — 1/2 inch FPT  
 Temperature — 33°F minimum, 90° maximum

**Heat of Rejection (BTU/Hr):**

Average 7,000, Peak 9,600

**Refrigerant R502:**

Air-Cooled — 22 oz.  
 Water-Cooled — 24 oz.  
 Remote — 256 oz.

## ELECTRICAL REQUIREMENTS

Voltage Phase Cycle	AIR		WATER		REMOTE	
	Maximum Fuse/Circuit Breaker	Minimum Circuit Ampacity	Maximum Fuse/Circuit Breaker	Minimum Circuit Ampacity	Maximum Fuse/Circuit Breaker	Minimum Circuit Ampacity
115/1/60	25	14.9	20	11.6	20	14
208-230/1/60	15	7.8	15	5.3	not available	
220-240/1/50	15	7.8	15	5.8	not available	

Numbers Listed Are Amps

**MANITOWOC ICE MACHINES ARE AIR CONDITIONING REFRIGERATION INSTITUTE (ARI) CERTIFIED AND RATED IN ACCORDANCE WITH AIR CONDITIONING REFRIGERATION INSTITUTE STANDARD 810-87**

**NOTE**

Test conditions for standard ratings at 90°F air, 70°F water, and 30 ± 2 psig water inlet pressure.

Model Designation	Capacity (Lb. per 24 Hr.)		Potable Water Used (Gal. per 100 Lb. of Ice)	Condenser Water Used (Gal. per 100 Lb. of Ice)	Power Input (kW/Hr. 100 Lb. of Ice)	
GR-0400A	297		29	--	7.7	
GD-0402A	320		29	--	7.7	
GY-0404A	320		29	--	7.7	
GR-0401W	353		27.5	151	6.4	
GD-0403W	380		27.5	151	5.9	
GY-0405W	380		27.5	151	5.9	
GR-0490N	334*	325#	29	--	8.1*	8.3#
GD-0492N	360*	350#	29	--	7.5*	7.7#
GY-0494N	360*	350#	29	--	7.5*	7.7#

\*With AC0496B Remote Condenser  
 #With DC0496A Remote Condenser

# WARRANTY INFORMATION

## IMPORTANT

Read this section very carefully for warranty explanation. (Refer to Warranty Bond for complete details.)

## OWNER WARRANTY REGISTRATION CARD

Warranty coverage begins the day the ice machine is installed.

## IMPORTANT

To validate the installation date, the OWNER WARRANTY REGISTRATION CARD must be mailed in.

If the card was not returned, Manitowoc will use the date of sale to the Manitowoc Distributor as the first day of warranty coverage for your new ice machine.

## About Your Warranty

Contact your local Manitowoc representative or our Wisconsin factory for further warranty information.

## WARRANTY COVERAGE

**(Effective for Ice Machines Installed after January 1, 1991)**

### Parts

1. The ice machine is warranted against defects in materials and workmanship under normal use and service for three (3) years from the date of the original installation. It is important to send in the warranty registration card so Manitowoc can begin your warranty on the installation date.
2. An additional two (2) years (five years total) warranty is provided on evaporator and compressor from the date of original installation.

### Labor

1. Labor to repair or replace defective components is warranted for three (3) years from the date of original installation.
2. An additional two (2) years (**five (5) years total**) labor warranty is provided on the evaporator from the date of original installation.

### Exclusions from Warranty Coverage

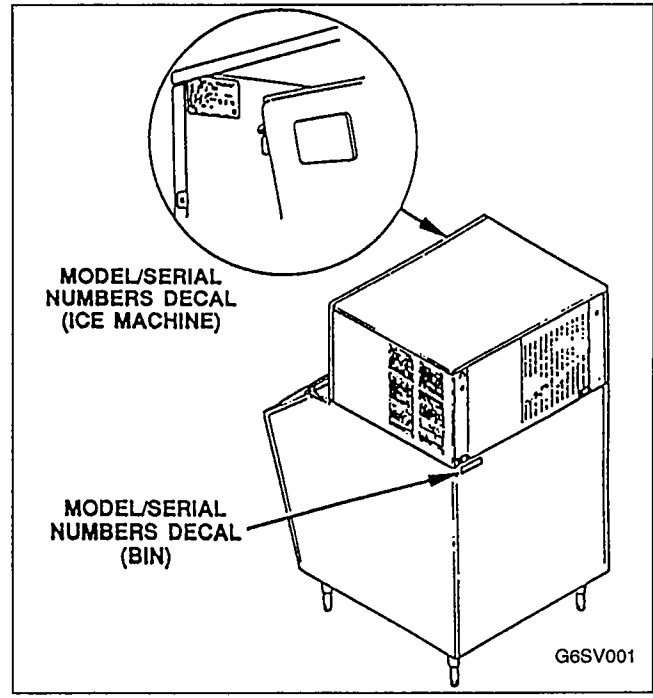
The following items are not included in the warranty coverage of the ice machine.

1. Normal maintenance, adjustments and cleaning as outlined in the Use and Care Guide.
2. Repairs due to unauthorized modifications to the ice machine or the use of nonapproved parts without written approval from Manitowoc Ice, Inc.
3. Damage from improper installation as outlined in the Installation Instructions, improper electrical supply, water supply or drainage; flood, storms, or other acts of God.
4. Premium labor rates due to holidays, overtime, etc. Travel time, flat rate service call charges, mileage and miscellaneous tools and material charges not listed on the payment schedule are excluded as well as additional labor charges resulting from inaccessibility of the ice machine.
5. Parts or assemblies subjected to misuse, abuse, neglect or accidents.
6. When the ice machine has been installed, cleaned and/or maintained inconsistent with the technical instructions provided in the Owner/Operator Use and Care Guide and the Installation Manual.

### Authorized Warranty Service

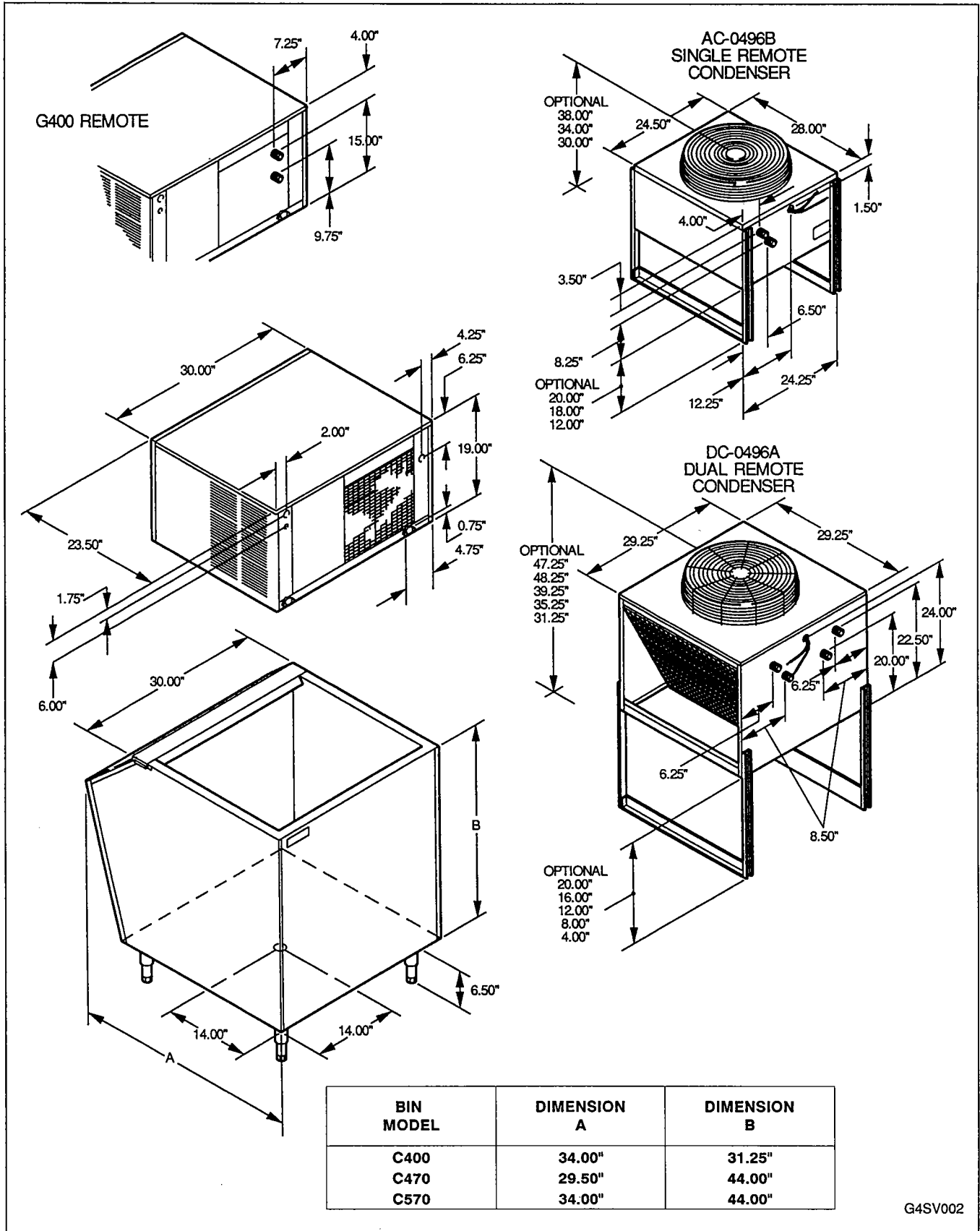
To comply with the provisions of the warranty a refrigeration service company qualified and authorized by a Manitowoc distributor or a Contracted Service Representative must perform the warranty repair.

Please contact your local Manitowoc Distributor or Manitowoc Ice, Inc. for further information regarding warranty coverage. (NOTE: Have model and serial numbers of ice machine available when calling. See Figure 1 for location of model and serial numbers.)



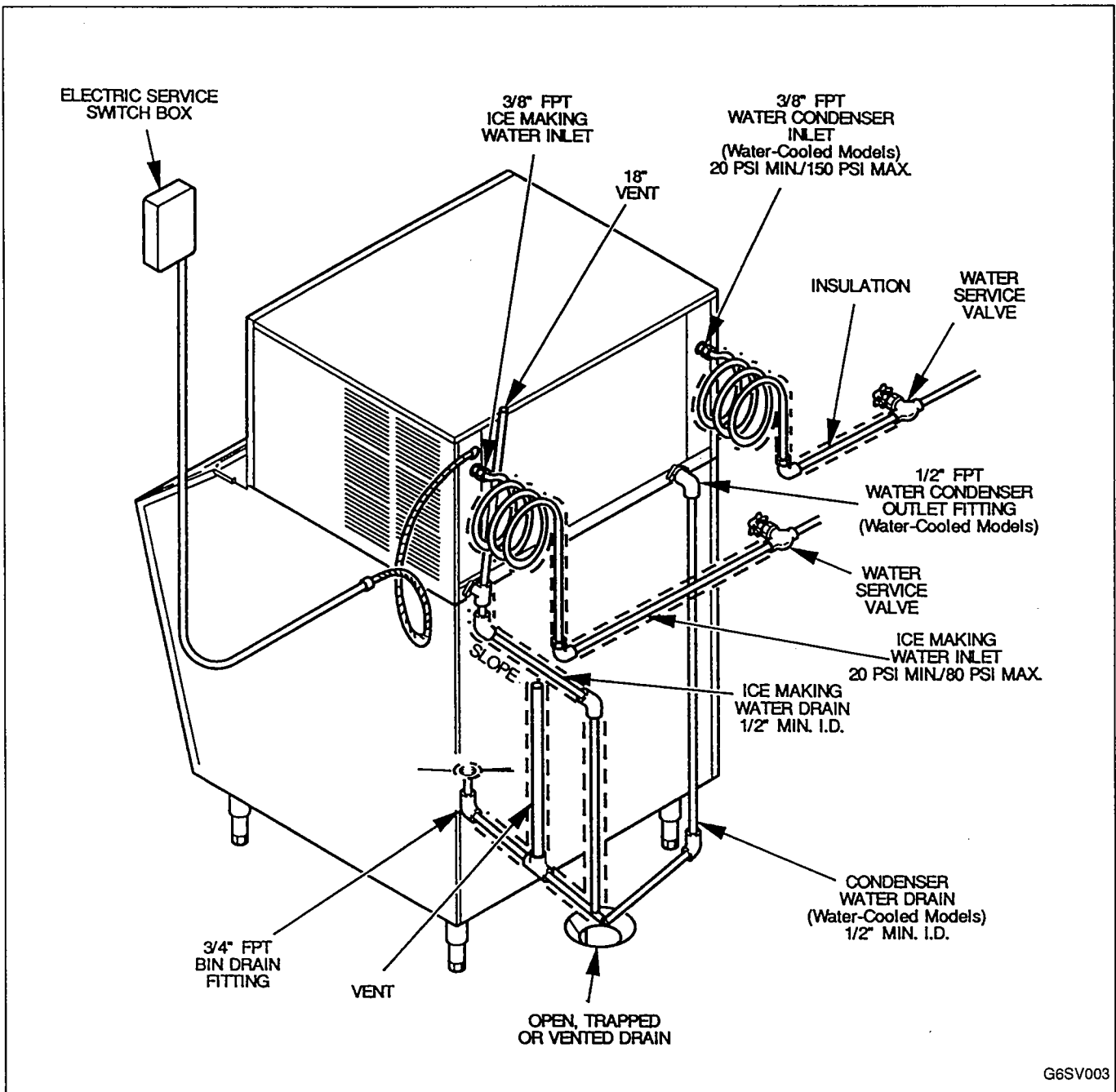
**FIGURE 1. MODEL/SERIAL NUMBERS LOCATION**

# DIMENSIONS



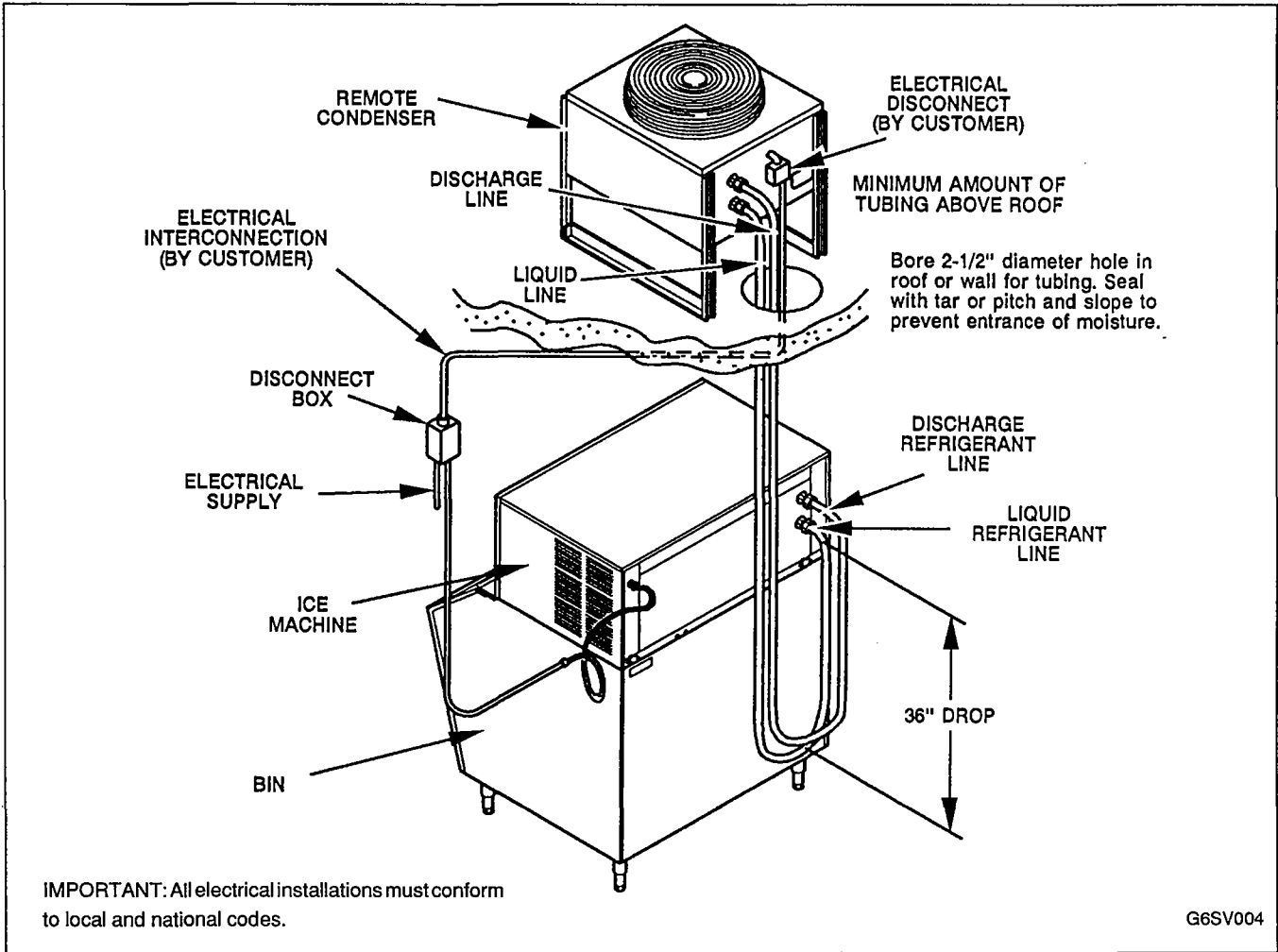
G4SV002

FIGURE 2. DIMENSIONS

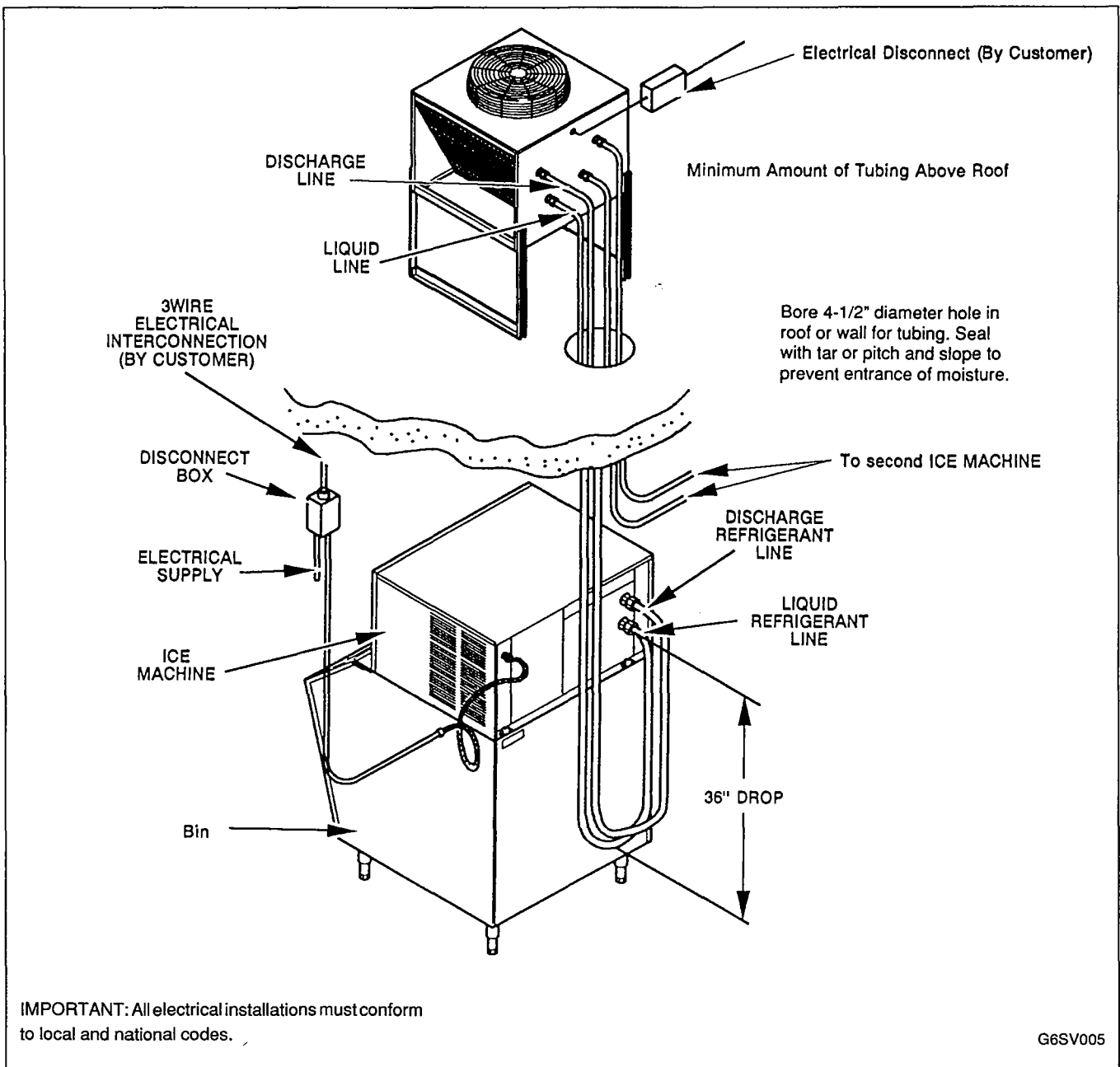


G6SV003

FIGURE 3. TYPICAL SELF-CONTAINED INSTALLATION

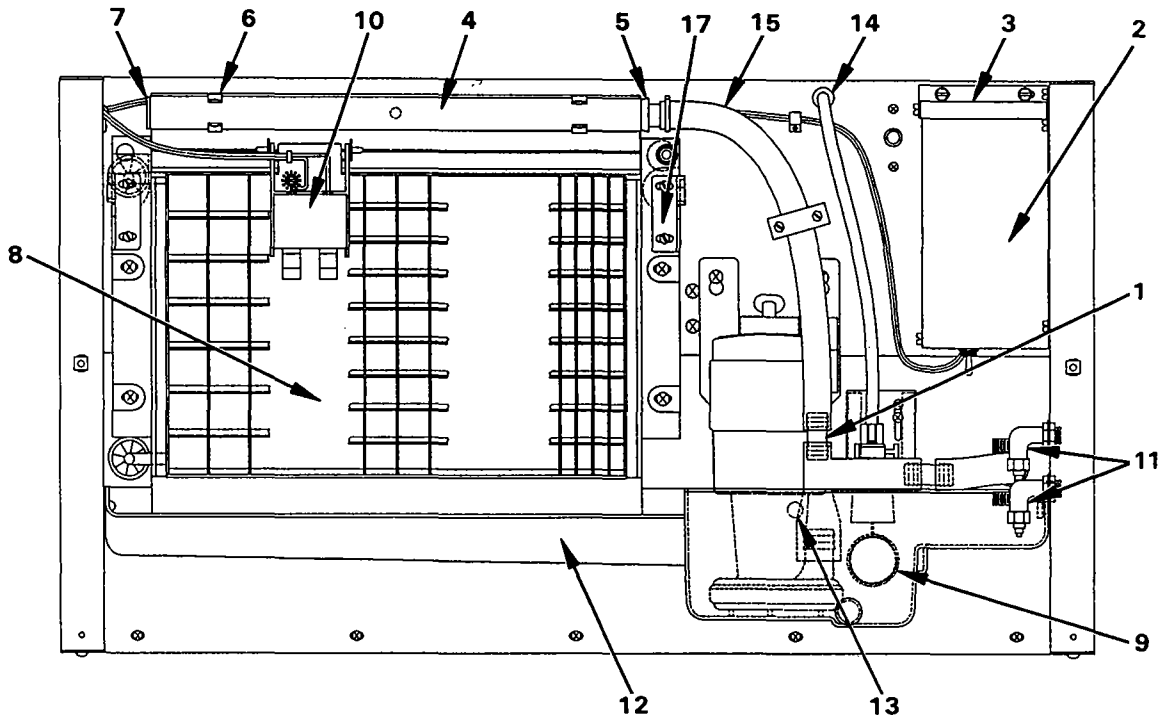


**FIGURE 4. TYPICAL REMOTE SINGLE (AC) CONDENSER INSTALLATION**



**FIGURE 5. TYPICAL REMOTE DUAL (DC) CONDENSER INSTALLATION**

# COMPONENT IDENTIFICATION

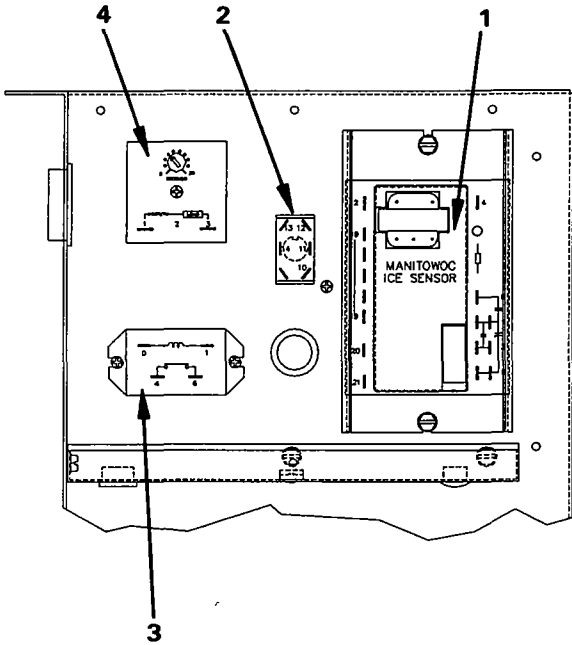


- |                                  |                                     |
|----------------------------------|-------------------------------------|
| 1. BARBED TEE                    | 10. ICE THICKNESS CONTROL           |
| 2. CONTROL BOX COVER             | 11. SERVICE VALVE                   |
| 3. CONTROL BOX TOP COVER         | 12. SUMP TROUGH                     |
| 4. DISTRIBUTION TUBE             | 13. THUMB SCREW                     |
| 5. DISTRIBUTION TUBE SEAL        | 14. TUBING, 1/4" POLYFLOW           |
| 6. DISTRIBUTION TUBE SPRING CLIP | 15. TYGON TUBING, 1/2" ID x 3/4" OD |
| 7. END PLUG                      | 16. WATER CURTAIN (NOT SHOWN)       |
| 8. EVAPORATOR ASSEMBLY           | 17. WATER CURTAIN HANGERS           |
| 9. FLOAT VALVE ASSEMBLY          |                                     |

G2SV004

FIGURE 6. WATER DISTRIBUTION GROUP AND OUTER PANELS

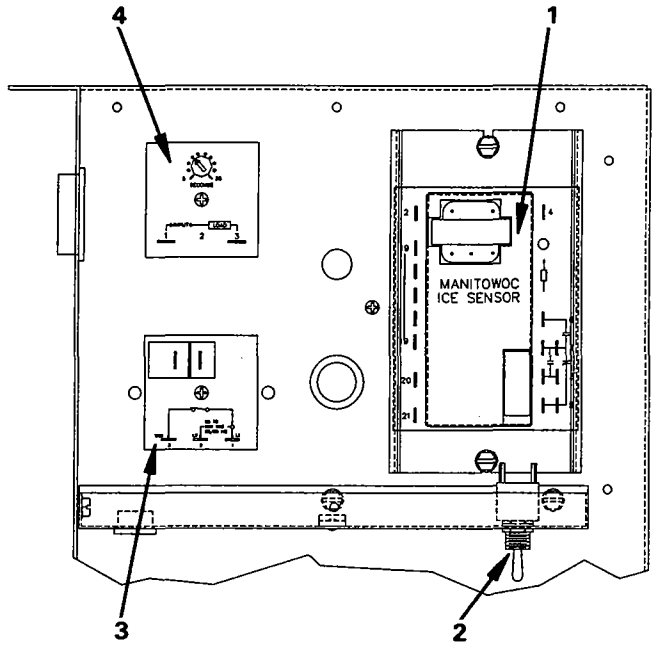
**REMOTE CONTROL BOX**



- 1. ICE SENSOR
- 2. TOGGLE SWITCH
- 3. COMPRESSOR/FAN RELAY
- 4. WATER PUMP DELAY TIMER

SV1147

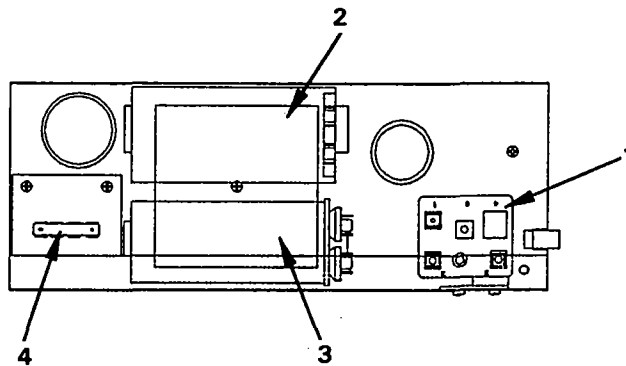
**AIR- AND WATER-COOLED CONTROL BOX**



- 1. ICE SENSOR
- 2. TOGGLE SWITCH
- 3. 7-SECOND OFF DELAY RELAY
- 4. WATER PUMP DELAY TIMER

SV1148

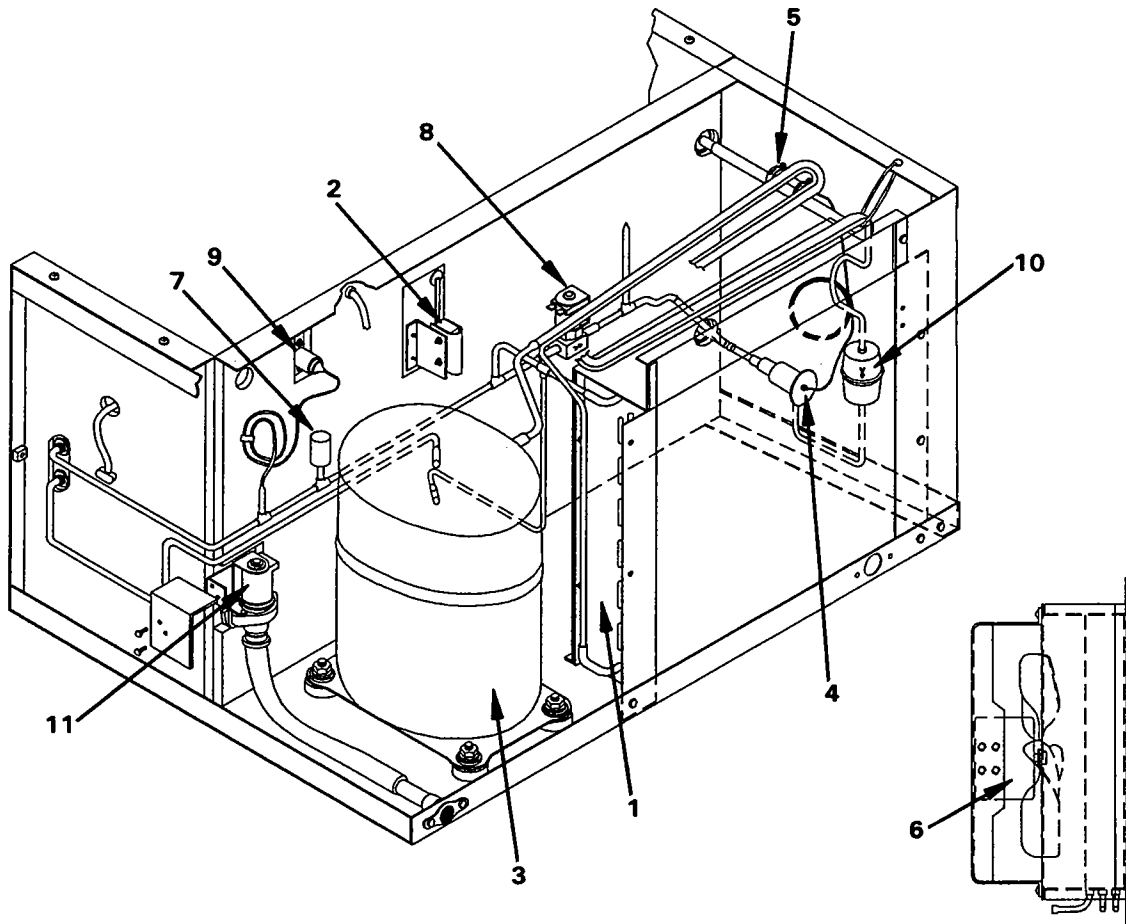
**SIDE CONTROL BOX**



- 1. START RELAY
- 2. START CAPACITOR
- 3. RUN CAPACITOR
- 4. TERMINAL STRIP

SV1152

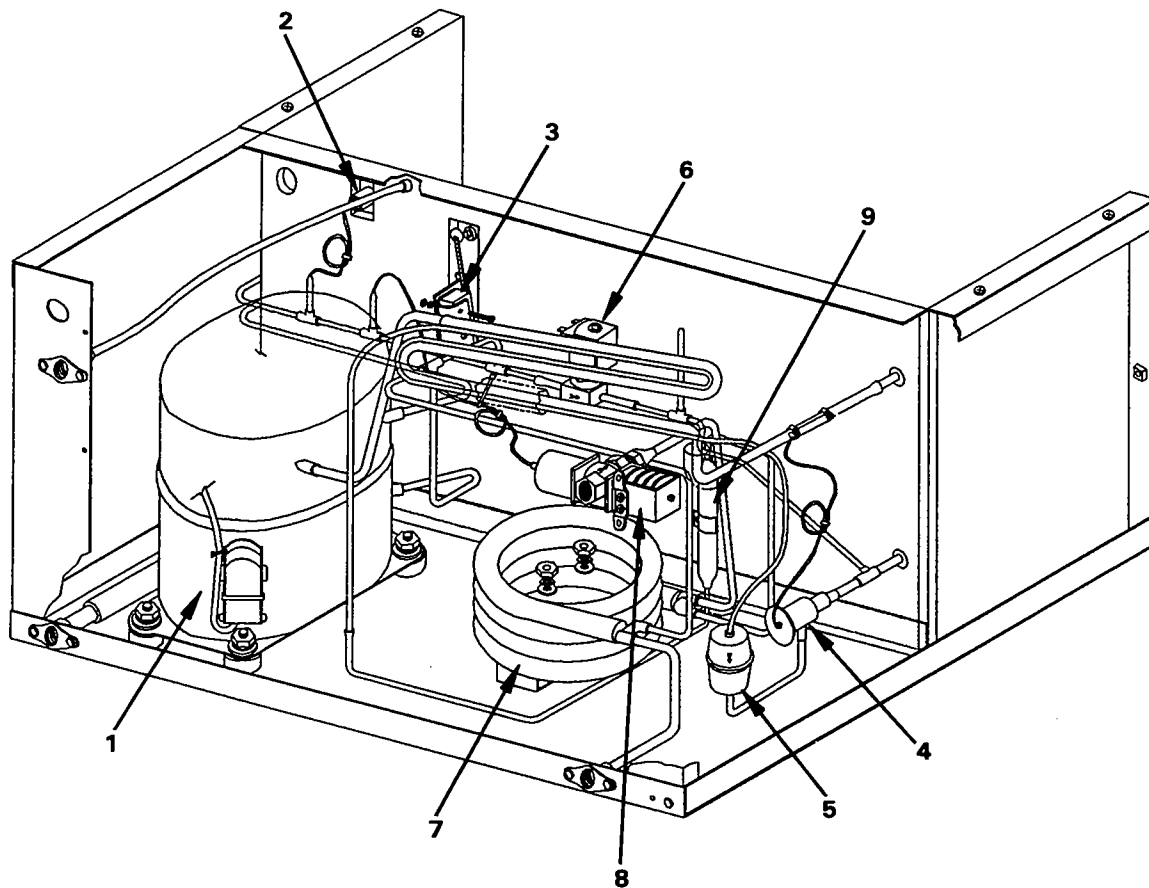
**FIGURE 7. CONTROL BOX ASSEMBLIES**



- 1. AIR CONDENSER
- 2. BIN SWITCH
- 3. COMPRESSOR
- 4. EXPANSION VALVE
- 5. EXPANSION VALVE BULB
- 6. FAN
- 7. FAN CYCLING CONTROL
- 8. HOT GAS SOLENOID
- 9. HIGH PRESSURE CUT-OUT
- 10. DRIER
- 11. WATER DUMP SOLENOID

SV1146

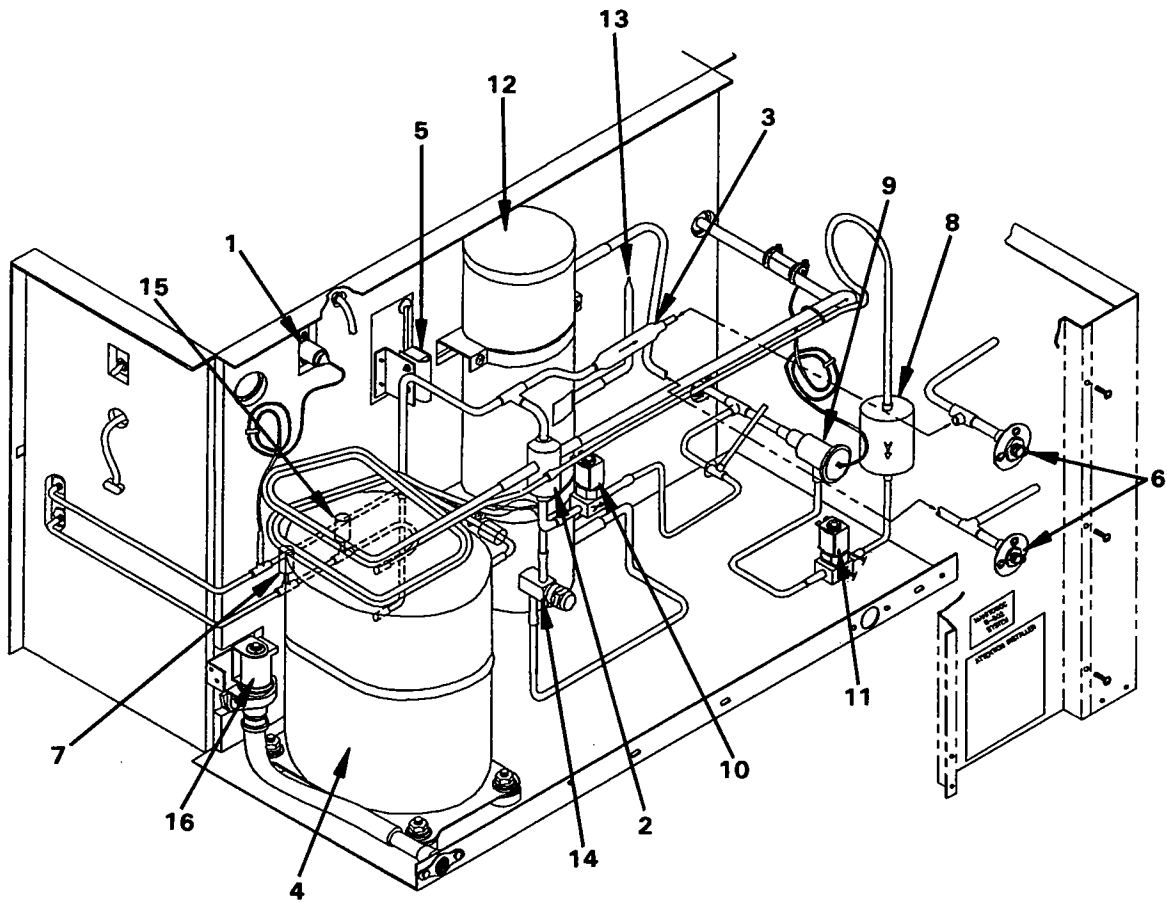
**FIGURE 8. COMPRESSOR COMPARTMENT (AIR-COOLED)**



- |                          |                           |
|--------------------------|---------------------------|
| 1. COMPRESSOR            | 6. HOT GAS SOLENOID       |
| 2. HIGH PRESSURE CUT-OUT | 7. WATER-COOLED CONDENSER |
| 3. BIN SWITCH            | 8. WATER REGULATING VALVE |
| 4. EXPANSION VALVE       | 9. RECEIVER               |
| 5. DRIER                 |                           |

SV1145

**FIGURE 9. COMPRESSOR COMPARTMENT (WATER-COOLED)**



- |                            |                                      |
|----------------------------|--------------------------------------|
| 1. HIGH PRESSURE CUT-OUT   | 9. EXPANSION VALVE                   |
| 2. HARVEST CYCLE RESERVOIR | 10. HOT GAS SOLENOID VALVE           |
| 3. CHECK VALVE             | 11. LIQUID LINE SOLENOID             |
| 4. COMPRESSOR              | 12. RECEIVER                         |
| 5. BIN SWITCH              | 13. RECEIVER SAFETY PLUG             |
| 6. COUPLING                | 14. SERVICE VALVE                    |
| 7. LOW PRESSURE CONTROL    | 15. SUCTION PRESSURE LIMITER CONTROL |
| 8. DRIER                   | 16. DUMP VALVE                       |

SV1144

**FIGURE 10. COMPRESSOR COMPARTMENT (REMOTE CONDENSER)**

# INTERIOR CLEANING

For efficient operation, clean and sanitize ice machine every six months.

## IMPORTANT

Do not use hot water. If ice machine requires cleaning and sanitizing more frequently, consult a qualified service company to test the water quality and recommend appropriate water treatment.

Before cleaning, check water dump valve for proper operation (see Cleaning Water Dump Valve, page 17). Deposits may accumulate in the valve causing leakage or restriction of water flow.

## REMOVAL OF PARTS FOR CLEANING

1. Loosen two screws holding front panel in place and remove front panel.
2. Set ICE/OFF/WATER PUMP switch at OFF after ice falls from evaporator at completion of harvest cycle, or set switch at OFF and allow ice to melt off evaporator.



### CAUTION

Never use any type of object to force ice from evaporator as damage may result.

3. Turn off water to the ice machine at water service valve(s).



### WARNING

Disconnect electric power to ice machine at the electric switch box before proceeding.

4. Stacked ice machines:
  - a. Remove top panel.
  - b. Lift ice chute up and out of ice machine.

5. Remove all ice from bin.
6. Remove water curtain.
7. Remove drain plug from water trough and allow water to drain into bin.

## REMOVE WATER PUMP (Figure 11)

1. Disconnect water pump power cord.

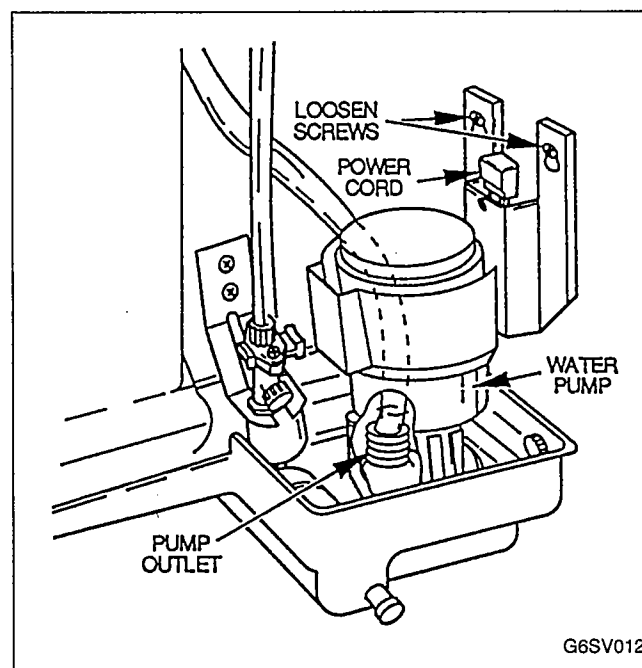


FIGURE 11. WATER PUMP REMOVAL

2. Disconnect hose from pump outlet.
3. Remove two screws holding pump mounting bracket to rear bulkhead.
4. Lift pump and bracket assembly off screws.

## REMOVE FLOAT VALVE (Figure 12)

1. Remove wing nuts from bracket and pull bracket from water trough.
2. Disconnect the water inlet tube from the float valve at the compression fitting.
3. Remove filter screen and cap.

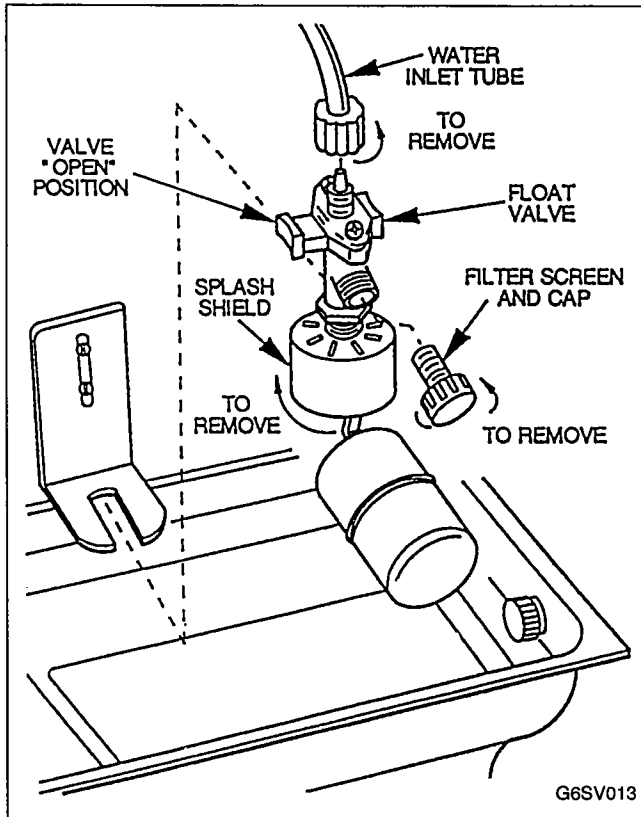


FIGURE 12. FLOAT VALVE REMOVAL

## REMOVE DISTRIBUTION TUBE (Figure 13)

1. Remove distribution tube from the two spring clips holding it in place.
2. Disconnect the hose from the distribution tube and from the "T".

### NOTE

To reinstall distribution tube, align locating pin on top extrusion with hole in distribution tube.

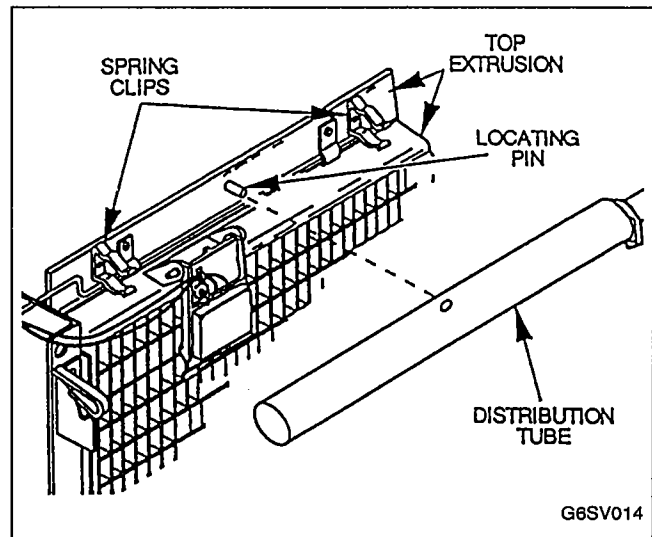


FIGURE 13. DISTRIBUTION TUBE REMOVAL

## DISASSEMBLE DISTRIBUTION TUBE (Figure 14)

### NOTE

Disassembly of the distribution tube is not usually necessary as normal cleaning of the ice machine will clean the tube. The distribution tube should only be disassembled if, after normal cleaning procedures, there is inadequate water flow from the distribution tube. (Ensure that any other water problems are eliminated beforehand.)

1. Heat rubber end plugs on distribution tube in warm water to soften them.
2. Remove end plugs and inner distribution tube.
3. Reheat rubber plugs in warm water after cleaning is complete and reassemble distribution tube.

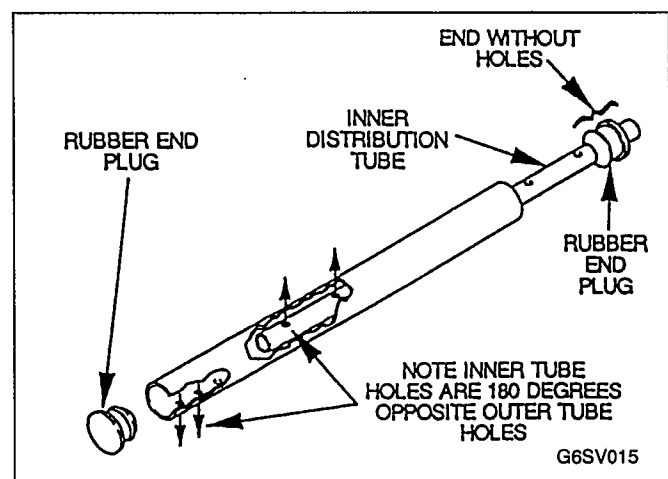


FIGURE 14. DISTRIBUTION TUBE DISASSEMBLY

### NOTE

Position the holes in the inner and outer tubes 180° opposite each other when reassembling. The end of the inner distribution tube without holes must extend from the outer tube when reassembled to allow for attachment of the water line from the pump.

## REMOVE ICE THICKNESS PROBE (Figure 15)

### ⚠ WARNING

Disconnect electric power to ice machine at the electric service switch box before proceeding.

1. Disconnect wire leads from inside electrical control box.
2. Compress side of probe at top near hinge pin and disengage it from the bracket.

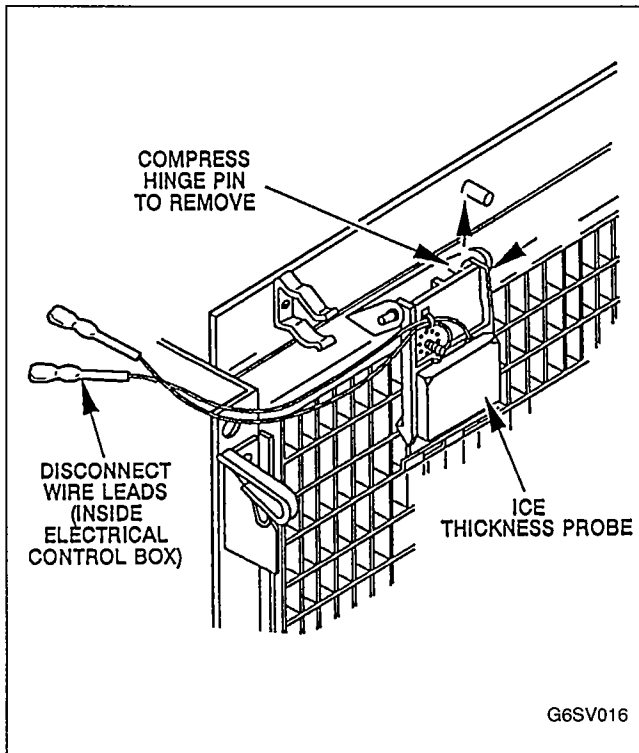


FIGURE 15. ICE THICKNESS PROBE REMOVAL

## REMOVE WATER TROUGH (Figure 16)

1. Remove thumb screws. Support trough while removing thumb screws.
2. Lower right side of trough into bin while disengaging left side of trough from holding pegs and remove trough from ice machine.

### NOTE

Stacked ice machines: Remove trough from top ice machine by lifting up on front right side of trough, then pull out to disengage trough from pegs on left side of cabinet.

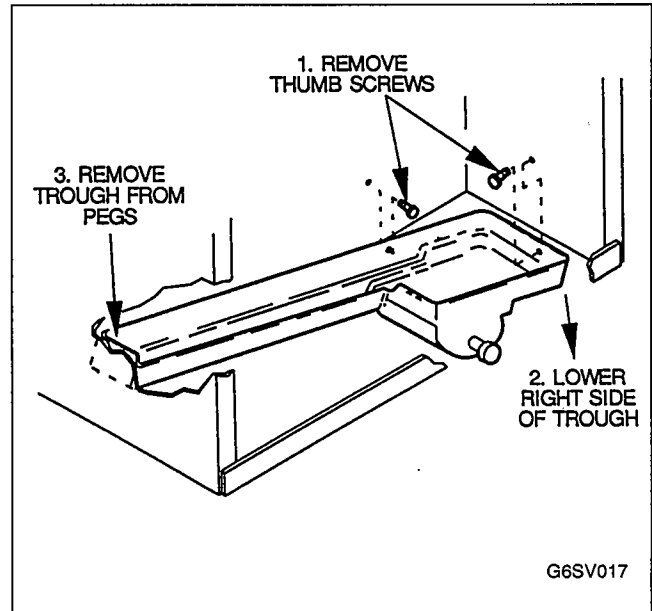


FIGURE 16. WATER TROUGH REMOVAL

## CLEANING PROCEDURES

Ice Machine Cleaner is for removal of lime scale or other mineral deposits. It is not used for removal of algae or slime. Refer to Sanitizing for removal of algae and slime.

### ⚠ CAUTION

Use only Manitowoc Ice Machine Cleaner, Part No. 94-0546-3, in recommended concentration as this is compatible with materials used in the manufacture of Manitowoc Ice Machines.

1. Soak parts in a solution of no more than 16 ounces of cleaner to one gallon of warm water. Use a brush (**DO NOT USE A WIRE BRUSH**) or a sponge to clean the parts, taking care not to damage them.

### ⚠ CAUTION

*Do not* immerse the water pump motor in the cleaning solution. Also, use care when cleaning the ice thickness probe so as not to move the adjusting screw.

2. Use the cleaning solution and a brush or sponge to remove scale build-up from the top, sides and bottom extrusions, the inside of the ice machine panels, and the entire inside of the ice bin.

A dirty top extrusion, Figure 13, could result in uneven water flow over the evaporator. Ensure all scale and dirt are removed.

3. Thoroughly rinse with clean water all parts and surfaces washed with the cleaning solution.

**NOTE**

Incomplete rinsing of the ice thickness probe could leave residue which could cause the ice machine to go into premature harvest. For best results, brush or wipe off while rinsing and then wipe dry.

4. Reinstall all parts removed for cleaning except front panel and top chute (if stacked).

**CLEAN THE EVAPORATOR SURFACE**

**NOTE**

Failure to clean other parts prior to evaporator may result in poor cleaning of the evaporator surface.

1. Turn on water to ice machine at water service valve and verify float valve is open, Figure 39.
2. Allow trough to fill to proper operating level, Figure 39.

3. Set ICE/OFF/WATER PUMP switch at WATER PUMP.
4. Add two ounces of cleaner to water trough and allow solution to circulate a maximum of 10 minutes.

**NOTE**

Use a soft brush on excessively dirty evaporator to help remove deposits. Ensure connecting holes in back corners of cube molds are open.

5. Set ICE/OFF/WATER PUMP switch at OFF.
6. Shut off water at float valve. See Figure 39.
7. Drain water trough by removing drain plug.
8. Thoroughly rinse trough with clean water, then reinstall drain plug.
9. Turn on water at float valve.
10. Set ICE/OFF/WATER PUMP switch at WATER PUMP and allow water trough to fill to proper operating level.
11. Sanitize ice machine after cleaning.
12. Perform Operational Checks. Refer to Owner/Operator Use and Care Guide.

# SANITIZING

Sanitizer is used for removal of algae or slime AND AFTER USE OF MANITOWOC ICE MACHINE CLEANER. It is not used for removal of lime scale or other mineral deposits.

1. Loosen two screws holding front panel in place and remove front panel.
2. Set ICE/OFF/WATER PUMP switch at OFF after ice falls from evaporator at completion of harvest cycle or set switch at OFF and allow ice to melt off evaporator.



## CAUTION

Never use any type of object to force ice from evaporator as damage may result.

3. Stacked ice machines: Remove ice chute as described under Removal of Parts for Cleaning, step 4, page 13.
4. Remove water curtain, Figure 42.
5. Remove all ice from bin.

6. Set ICE/OFF/WATER PUMP switch at WATER PUMP.
7. Add one ounce of sanitizer to water trough and allow solution to circulate a minimum of one minute.
8. Drain solution from trough by removing drain plug, Figure 39.
9. Thoroughly rinse trough with clean water, then reinstall drain plug.
10. Wash all surfaces requiring sanitizing (ice machine and bin) with a solution of one ounce of sanitizer to up to four gallons of water.
11. Thoroughly rinse all sanitized surfaces with clean water.
12. Set ICE/OFF/WATER PUMP switch at ICE.
13. Perform Operational Checks. Refer to Owner/Operator Use and Care Guide. Discard first batch of ice.

# CHECKING AND CLEANING THE WATER DUMP VALVE

## NOTE

This covers the Alco water dump valve only.

## OPERATION CHECK

1. Remove top and right side panel.
2. Set ICE/OFF/WATER PUMP switch at ICE.
3. Check clear plastic outlet drain hose of dump valve, Figure 17, for leakage while the ice machine is in the freeze cycle.
4. If the dump valve is leaking or restricted, remove, disassemble and clean.

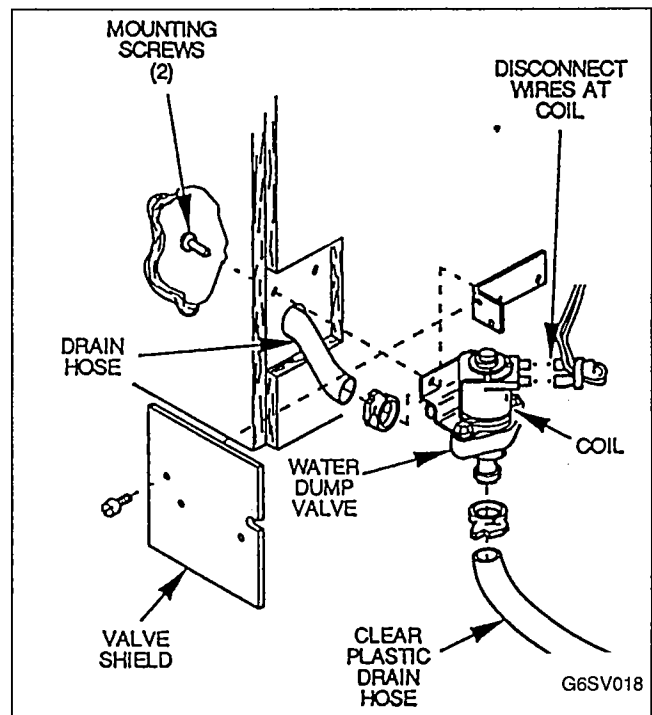


FIGURE 17. WATER DUMP VALVE REMOVAL

## REMOVE WATER DUMP VALVE (Figure 17)

### WARNING

Disconnect electric power to the ice machine at the electric service switch box.

### NOTE

Water dump valve can be cleaned without removing.

1. Drain water trough by removing drain plug.
2. Remove water dump valve shield from water dump valve mounting bracket.
3. Disconnect wires from dump valve coil.
4. Remove two screws securing dump valve to mounting bracket.
5. Remove tubing from dump valve by twisting off hose clamps.

## DISASSEMBLE WATER DUMP VALVE (Figure 18)

1. Lift cap and slide coil retainer cap from top of coil.

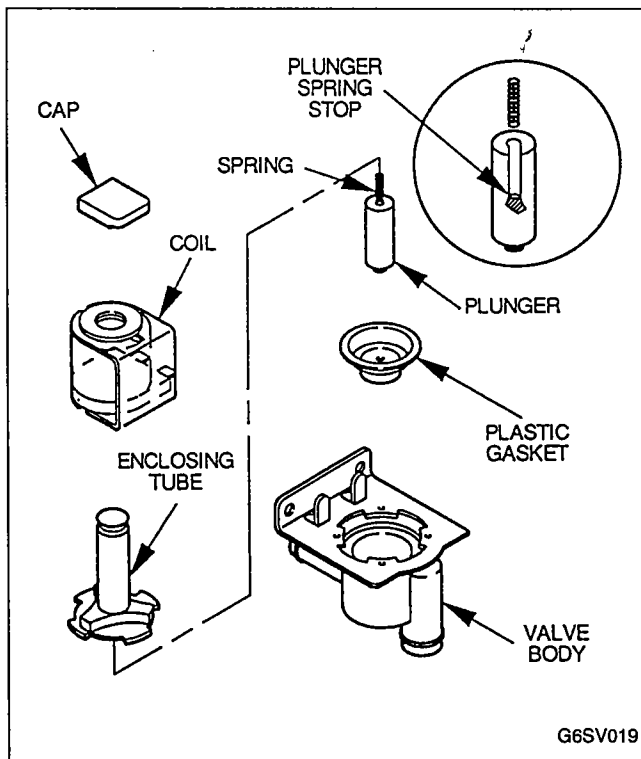


FIGURE 18. WATER DUMP VALVE DISASSEMBLY

2. Lift coil assembly off valve body. Note position of coil assembly on valve before removing. When reassembling valve, ensure coil is in same position.
3. Place spanner tool (Manitowoc Part No. 54-8907-3, available through your local Manitowoc Distributor) over enclosing tube and insert pins on spanner tool into holes on bottom of tube.
4. Turn spanner tool counterclockwise with 7/8" wrench and remove enclosing tube, plunger and rubber gasket from valve body.

## CLEANING WATER DUMP VALVE

### NOTE

It is not necessary to remove spring from plunger when cleaning. If spring is removed, insert *flared* end of spring into slotted opening in top of plunger until spring comes in contact with plunger spring stop. Use care not to stretch or damage spring in plunger when cleaning.

Replace excessively dirty or worn water dump valve components. Order Water Dump Valve Rebuild Kit, Part No. 24-0487-3. Contact your Manitowoc Distributor.

1. Soak components in cleaning solution (refer to Cleaning Procedures, page 15). Remove heavy scale deposits with a stiff-bristle brush. Use a small bottle brush to clean inside the enclosure tube. Wipe off rubber gasket with soft cloth.

### CAUTION

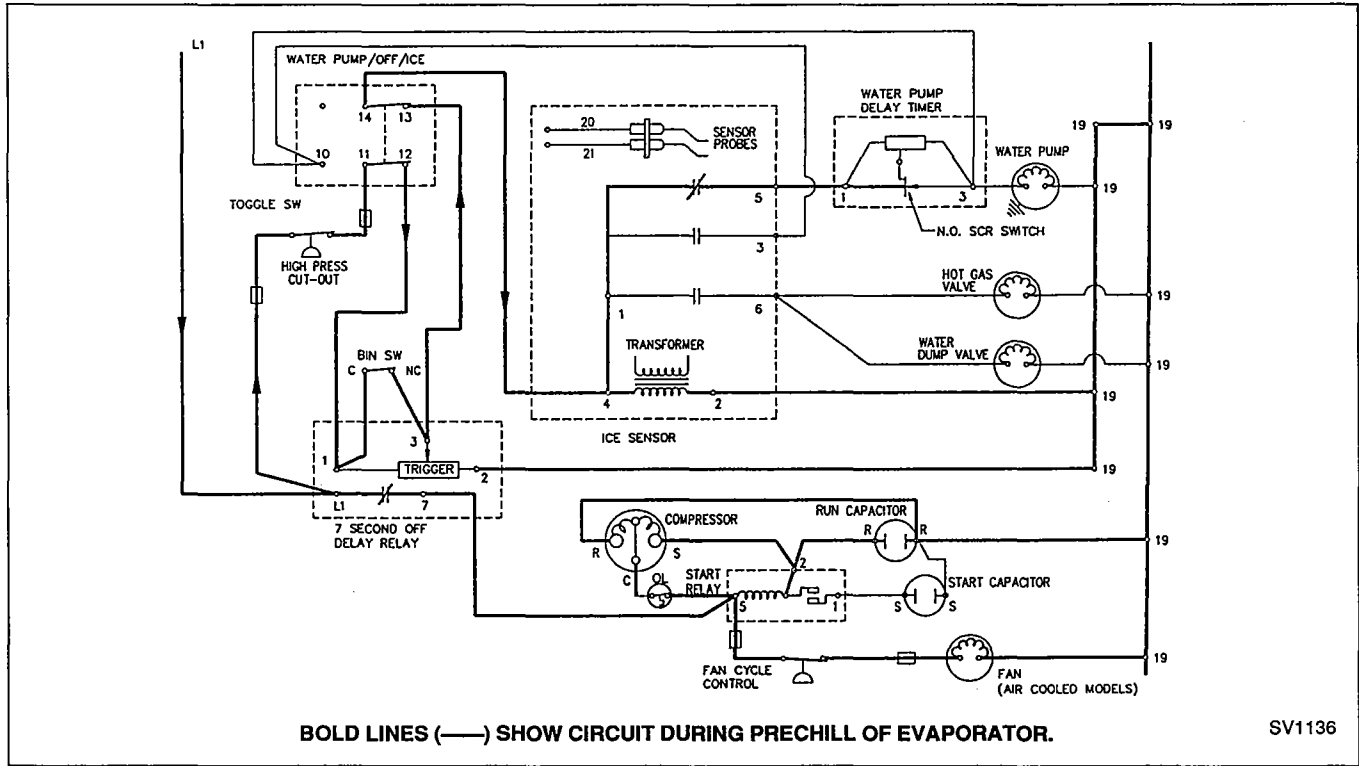
Do not soak coil assembly.

2. Thoroughly rinse components with clean water.
3. Reassemble water dump valve and reinstall in ice machine.

# ELECTRICAL SYSTEM SEQUENCE OF OPERATION SELF-CONTAINED AIR AND WATER COOLED

## **FREEZE CYCLE (Prechill of Evaporator)**

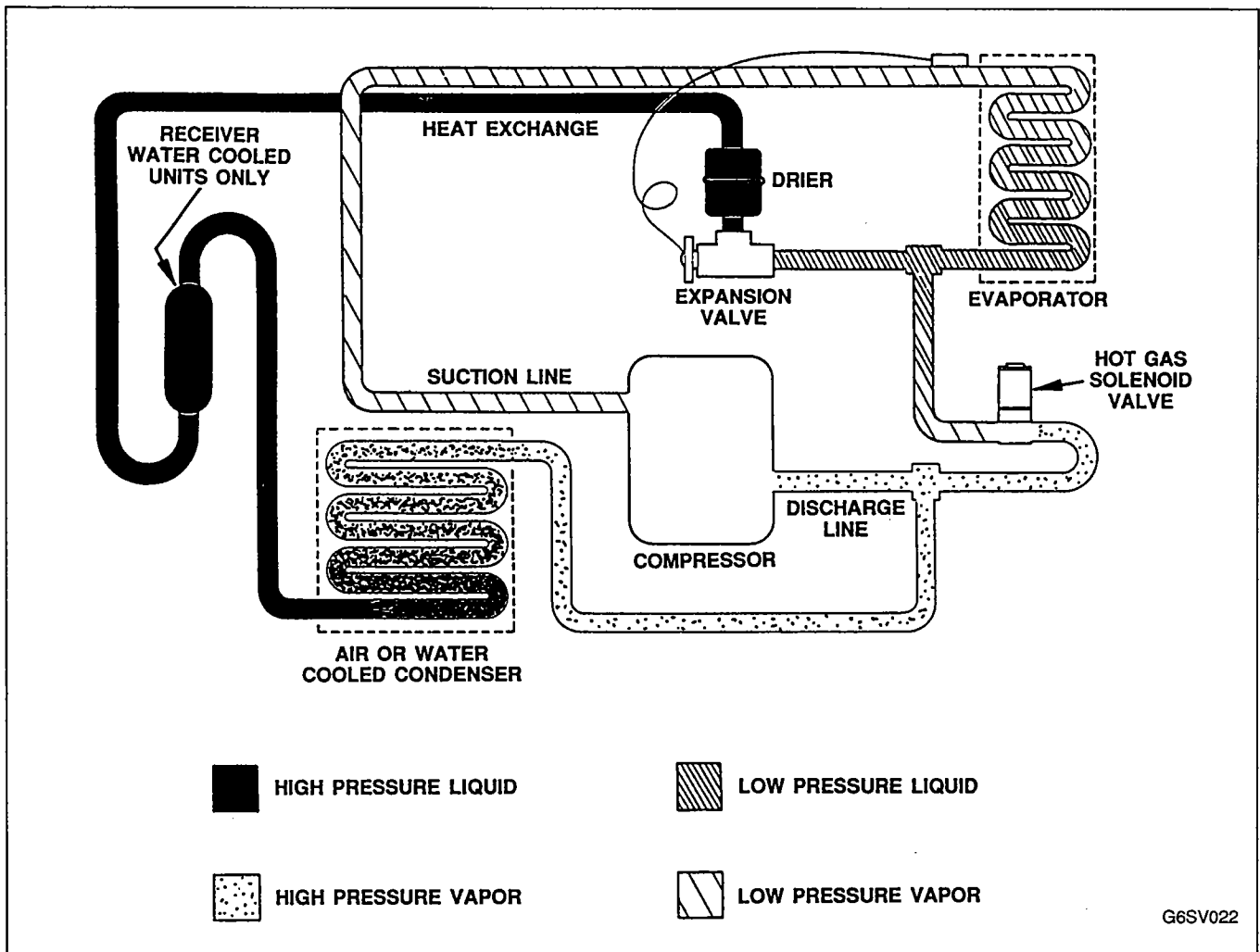
At the beginning of the freeze cycle the water pump will not start for 20 seconds. This allows the evaporator to prechill, minimizing build-up of slush in the sump trough.



**FIGURE 19. PRECHILL ELECTRICAL SEQUENCE**

### **Prechill Electrical Sequence**

- |    |  |           |                    |
|----|--|-----------|--------------------|
| 1. | Bin switch   | . . . . . | closed             |
| 2. | High Pressure Cut-Out control                                    | . . . . . | closed             |
| 3. | Toggle switch  | . . . . . | ice position       |
| 4. | Primary power to transformer                                     | . . . . . | yes                |
| 5. | Ice Sensor Relay   | . . . . . | not energized      |
|    | A) Ice Sensor Relay contact #6                                   | . . . . . | open               |
|    | 1. Hot gas solenoid  | . . . . . | not energized      |
|    | 2. Dump valve solenoid   | . . . . . | not energized      |
|    | B) Ice Sensor Relay contact #3                                   | . . . . . | open               |
|    | (water pump circuit during harvest cycle)                        |           |                    |
|    | C) Ice Sensor Relay contact #5                                   | . . . . . | closed             |
|    | 1. Water pump delay timer  | . . . . . | S.C.R. switch open |
|    | (the timer starts a preset 20-second delay period)               |           |                    |
|    | D) Water pump  |           |                    |
|    | (through Ice Sensor Relay contact #5 and water pump delay timer) | . . . . . | off                |
| 6. | 7-Second Delay Relay (contacts between L1 and 7)                 | . . . . . | closed             |
|    | A) Fan motor (air-cooled models)                                 | . . . . . | on                 |
|    | (fan cycle control may cycle fan on and off)                     |           |                    |
|    | B) Compressor  | . . . . . | on                 |



**FIGURE 20. PRECHILL REFRIGERATION SEQUENCE**

**Prechill Refrigeration Sequence**

There is no water flow over the evaporator during the prechill. The refrigerant absorbs heat (picked up during the harvest cycle) from the evaporator plate. The suction pressure decreases during prechill.

**Prechill Water Flow Sequence**

Water does not flow during the prechill.

## FREEZE CYCLE (Self-Contained Air or Water Cooled)

The freeze cycle begins when the Water Pump Delay Timer completes the 20-second delay and starts the water pump.

The water flows over the evaporator, forming ice on evaporator. The freeze cycle will last approximately 15-30 minutes, depending on air and water conditions. (Refer to Cycle Time Chart, page 51.)

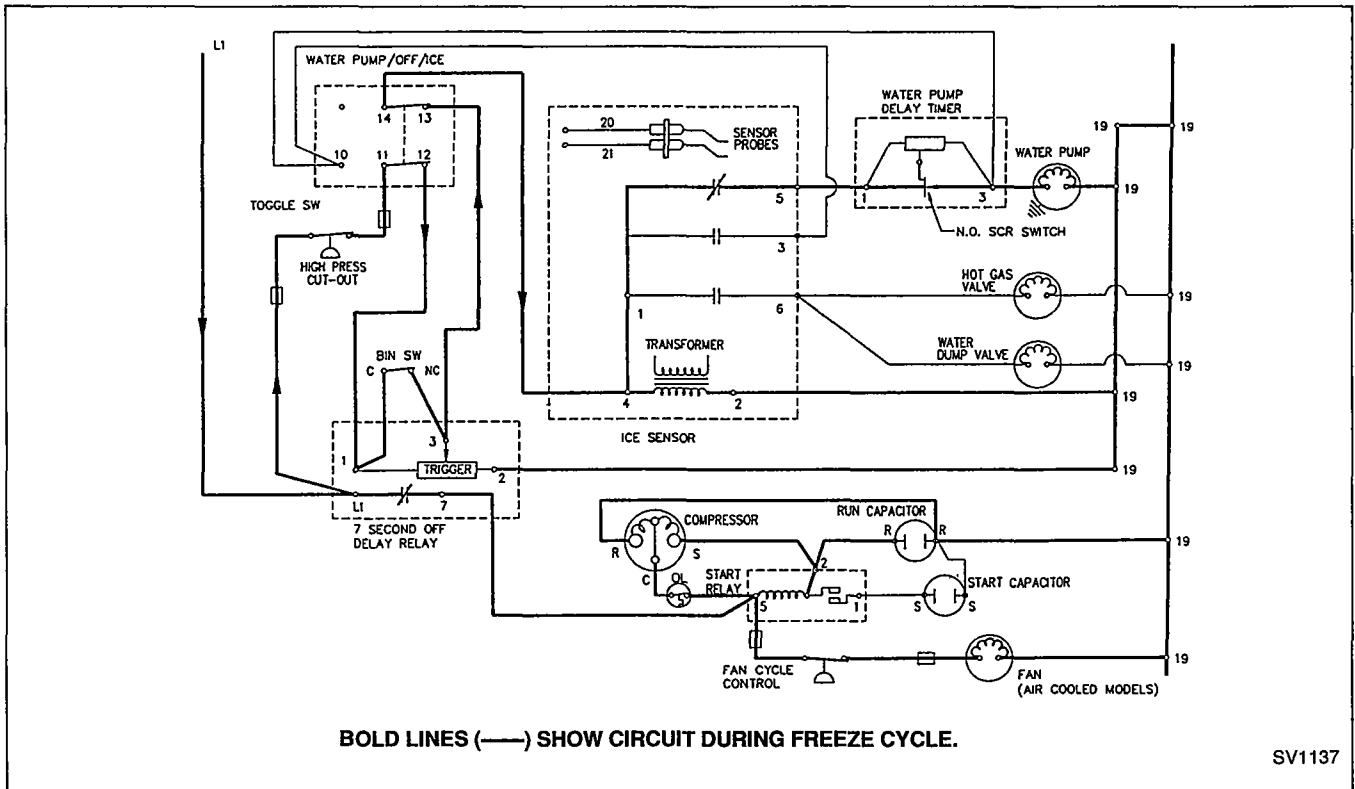
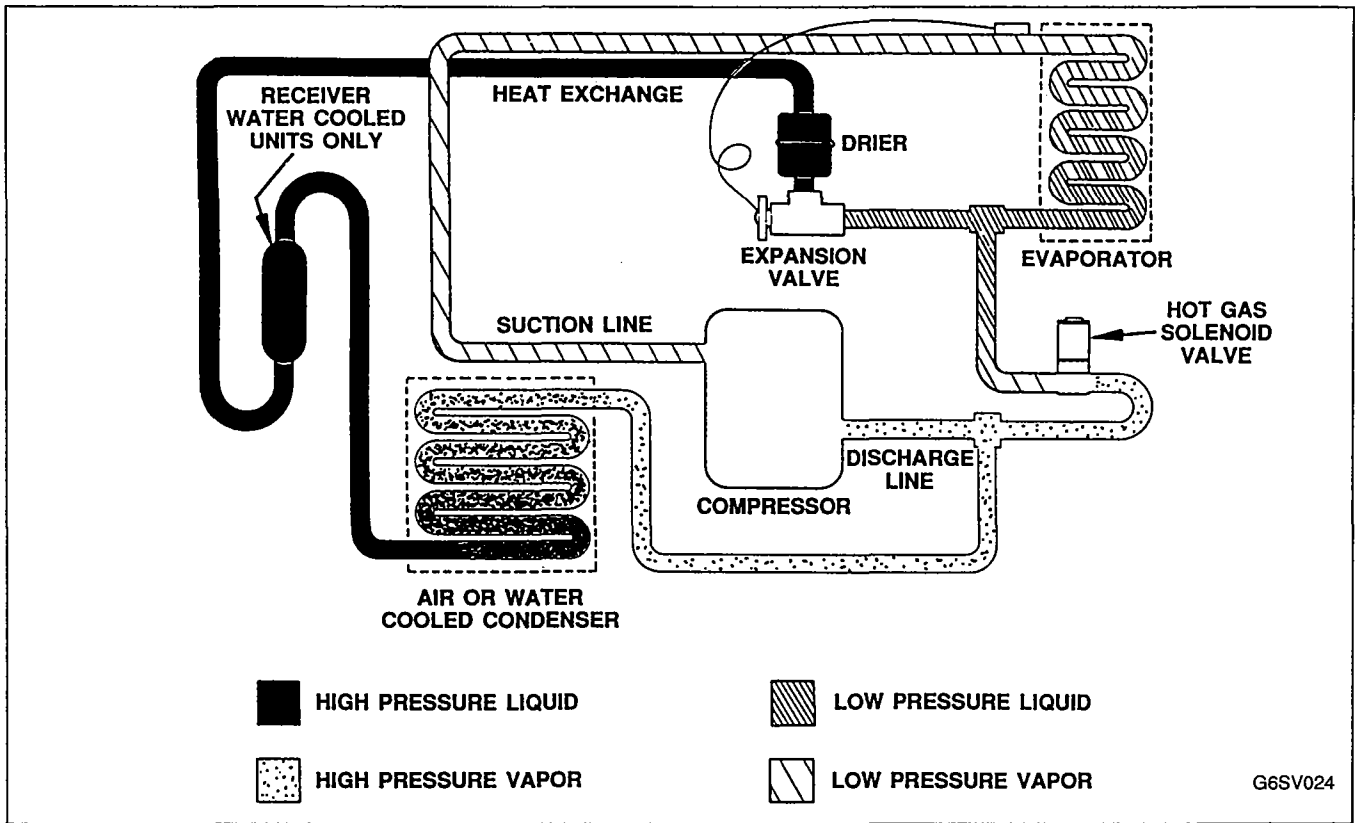


FIGURE 21. FREEZE CYCLE ELECTRICAL SEQUENCE

### Freeze Cycle Electrical Sequence

- |  |                      |
|--|----------------------|
| 1. Bin switch . . . . .  | closed               |
| 2. High Pressure Cut-Out control . . . . .                       | closed               |
| 3. Toggle switch . . . . .                                       | ice position         |
| 4. Primary power to transformer . . . . .                        | yes                  |
| 5. Ice Sensor Relay . . . . .                                    | not energized        |
| A) Ice Sensor Relay contact #6 . . . . .                         | open                 |
| 1. Hot gas solenoid . . . . .                                    | not energized        |
| 2. Dump valve solenoid . . . . .                                 | not energized        |
| B) Ice Sensor Relay contact #3 . . . . .                         | open                 |
| (water pump circuit during harvest cycle)                        |                      |
| C) Ice Sensor Relay contact #5 . . . . .                         | closed               |
| 1. Water pump delay timer . . . . .                              | S.C.R. switch closed |
| (the timer starts a preset 20-second delay period)               |                      |
| D) Water pump . . . . .  |                      |
| (through Ice Sensor Relay contact #5 and water pump delay timer) | on                   |
| 6. 7-Second Delay Relay (contacts between L1 and 7) . . . . .    | closed               |
| A) Fan motor (air-cooled models) . . . . .                       | on                   |
| (fan cycle control may cycle fan on and off)                     |                      |
| B) Compressor . . . . .  | on                   |



**FIGURE 22. FREEZE CYCLE REFRIGERATION SEQUENCE**

**Freeze Cycle Refrigeration Sequence**

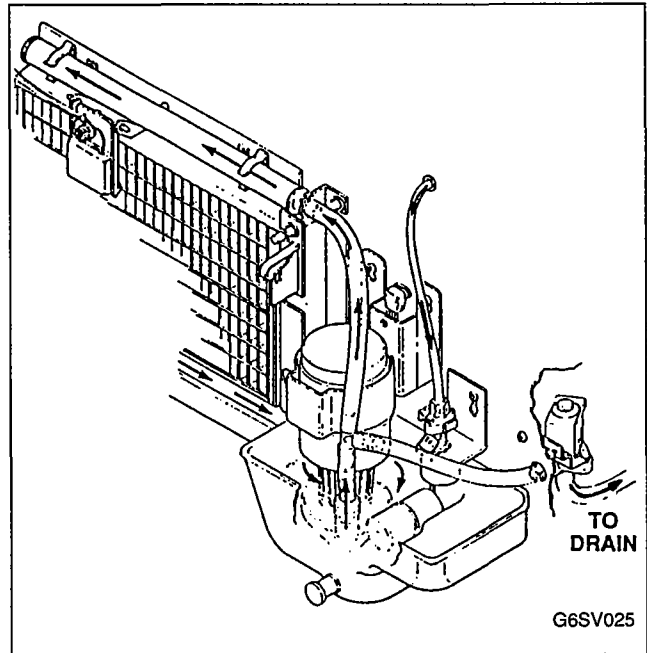
The refrigerant is absorbing heat from the water running over the evaporator surface. The suction pressure gradually drops as ice forms.

**Freeze Cycle Water Flow Sequence**

The water from the sump trough is pumped to the distribution tube above the evaporator. It flows evenly over the evaporator forming ice. The float valve maintains the proper water level in the sump trough.

**FREEZE CYCLE PRESSURES**

Ambient Temp. °F	Head Pressure PSIG	Suction Pressure PSIG
<b>Air Cooled</b>		
50	175-225	44-26
70	175-225	46-26
80	210-260	48-28
90	250-300	48-30
100	300-350	48-32
<b>Water Cooled</b>		
50	235-245	42-32
70	235-245	42-32
80	235-245	44-32
90	235-245	44-32
100	235-245	46-32



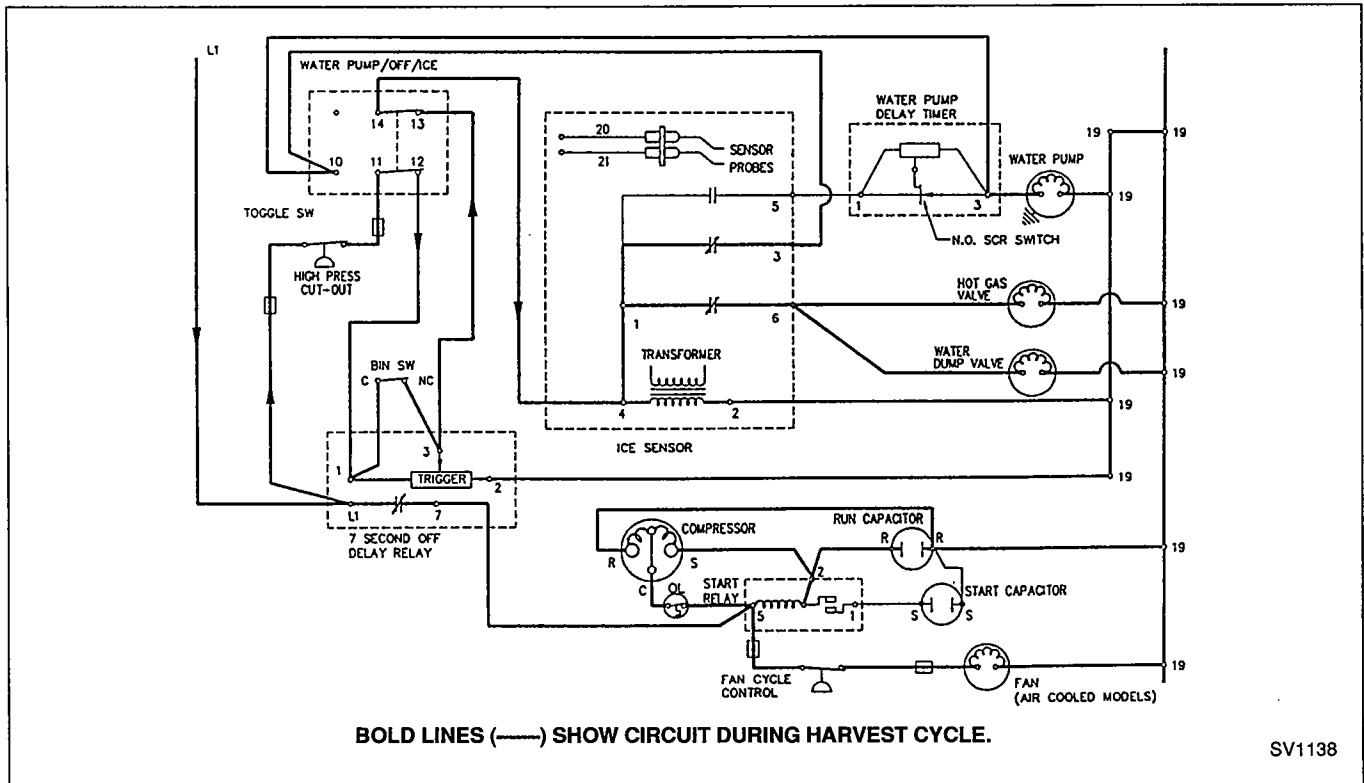
**FIGURE 23. FREEZE CYCLE WATER FLOW SEQUENCE**

## HARVEST CYCLE (Self-Contained Air or Water Cooled)

The harvest cycle begins when water flowing over the ice on the evaporator contacts the probes on the ice thickness control. After a constant 6-10 seconds of water contact, the relay in the unitized sensor board is energized, changing contacts #3, #5 and #6.

Water stops flowing over the evaporator and is pumped through the dump valve. As hot gas warms the evaporator,

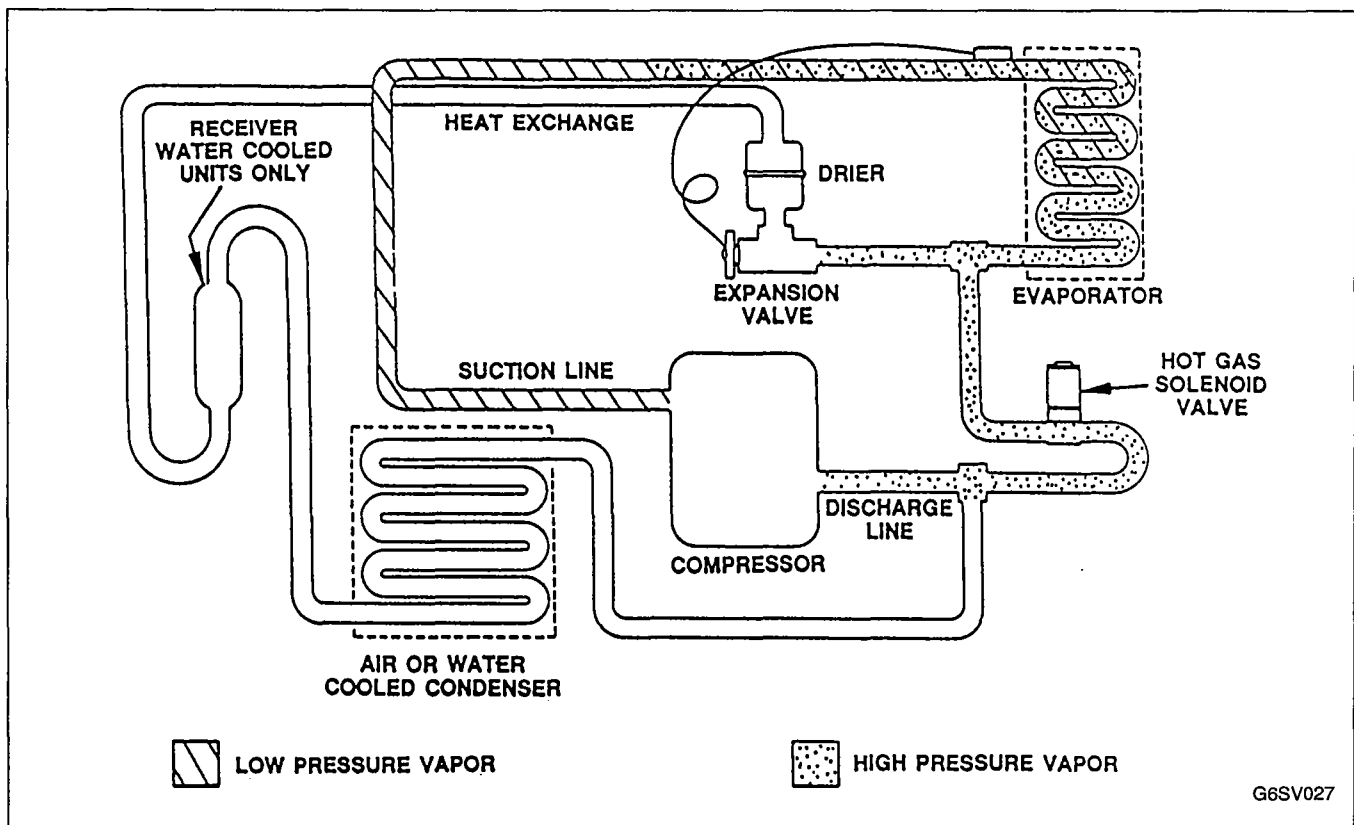
the ice cubes slide, as a unit, off the evaporator into the storage bin. The harvest cycle will last approximately 1 to 2 minutes. **Back to freeze cycle prechill:** the falling ice swings the bottom of the water curtain out, momentarily activating (opening) the bin switch. This interrupts the primary power supply at the transformer, de-energizing the ice sensor relay on the unitized sensor board.



**FIGURE 24. HARVEST CYCLE ELECTRICAL SEQUENCE**

### Harvest Cycle Electrical Sequence

- |    |  |                    |
|----|--|--------------------|
| 1. | Bin switch   | closed             |
| 2. | High Pressure Cut-Out control                      | closed             |
| 3. | Toggle switch                                      | ice position       |
| 4. | Primary power to transformer                       | yes                |
| 5. | Ice Sensor Relay                                   | energized          |
| A) | Ice Sensor Relay contact #6                        | closed             |
| 1. | Hot gas solenoid                                   | energized          |
| 2. | Dump valve solenoid                                | energized          |
| B) | Ice Sensor Relay contact #3                        | closed             |
|    | (water pump circuit during harvest cycle)          |                    |
| C) | Ice Sensor Relay contact #5                        | open               |
| 1. | Water pump delay timer                             | S.C.R. switch open |
|    | (the timer starts a preset 30-second delay period) |                    |
| D) | Water pump (through Ice Sensor Relay contact #3)   | on                 |
| 6. | 7-Second Delay Relay (contacts between L1 and 7)   | closed             |
| A) | Fan motor (air-cooled models)                      | on                 |
|    | (fan cycle control may cycle fan on and off)       |                    |
| B) | Compressor   | on                 |



**FIGURE 25. HARVEST CYCLE REFRIGERATION SEQUENCE**

**Harvest Cycle Refrigeration Sequence**

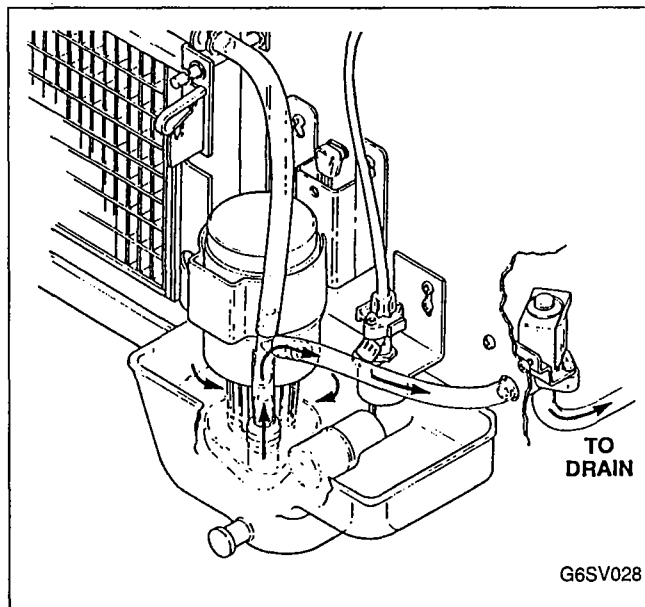
Hot gas flows through the energized hot gas valve heating the evaporator. The hot gas valve is sized to allow the proper amount of refrigerant into the evaporator. This specific sizing assures proper heat transfer without the refrigerant condensing and slugging the compressor.

**Harvest Cycle Water Flow Sequence**

The water from the sump trough is pumped through the energized dump valve and down the drain. The flushing of the minerals after each freeze cycle helps to keep the cubes clear and reduces the frequency of the ice machine cleanings.

**HARVEST CYCLE PRESSURES**

Ambient Temp. °F	Head Pressure PSIG	Suction Pressure PSIG
<b>Air Cooled</b>		
50	120-145	60-80
70	125-150	65-85
80	140-160	75-95
90	160-180	90-110
100	200-240	110-130
<b>Water Cooled</b>		
50	140-165	80-100
70	140-165	80-100
80	150-175	80-100
90	170-200	85-105
100	190-210	85-105

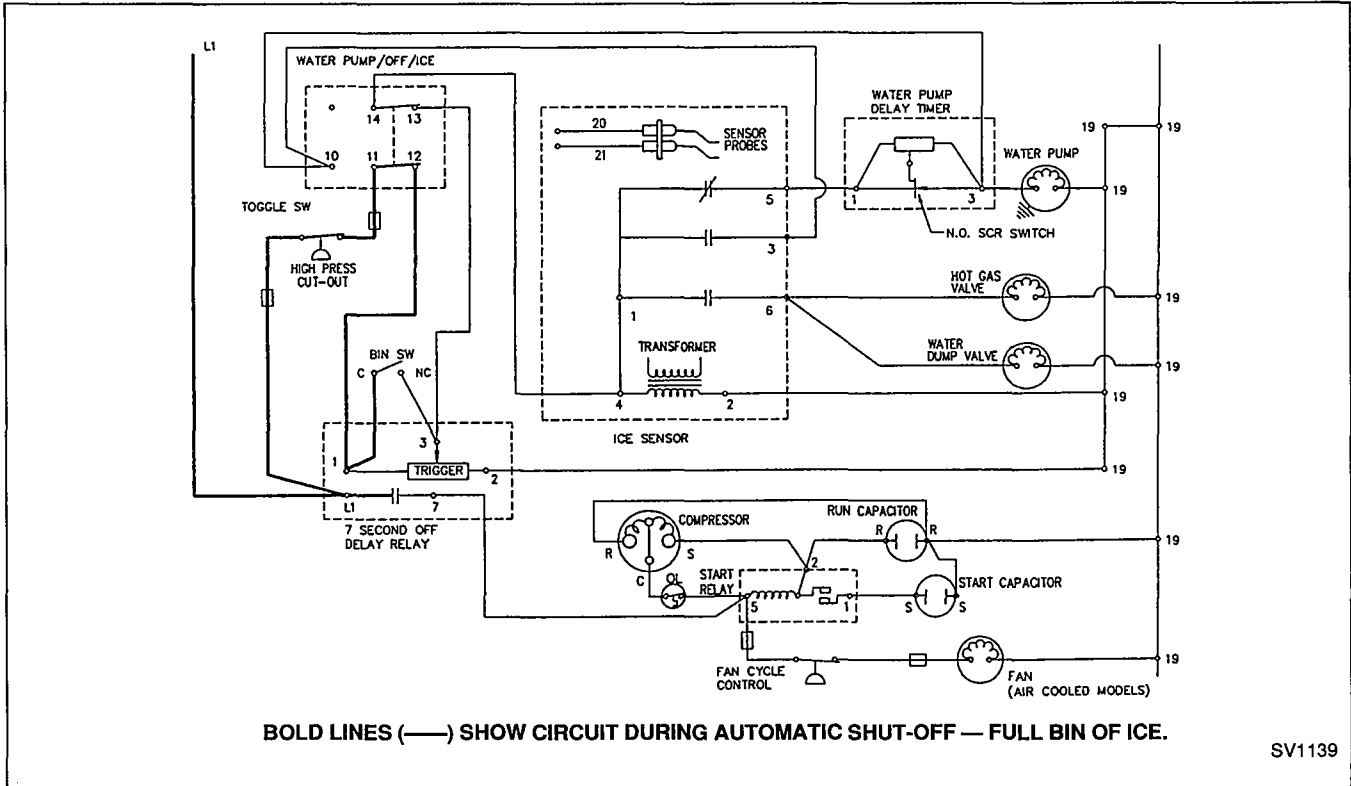


**FIGURE 26. HARVEST CYCLE WATER FLOW SEQUENCE**

# AUTOMATIC SHUT-OFF (Self-Contained Air or Water Cooled) (Full Bin of Ice)

When ice storage bin becomes full, the last harvesting ice cubes do not completely clear the water curtain. When the bin switch remains open for more than 7

seconds, the contact on the 7-second delay relay opens, de-energizing the compressor and fan motor. The open bin switch disconnects power to the other components. The return of the water curtain closes the bin switch and the ice machine starts a new freeze cycle.



**FIGURE 27. AUTOMATIC SHUT-OFF ELECTRICAL SEQUENCE**

### Automatic Shut-Off Electrical Sequence

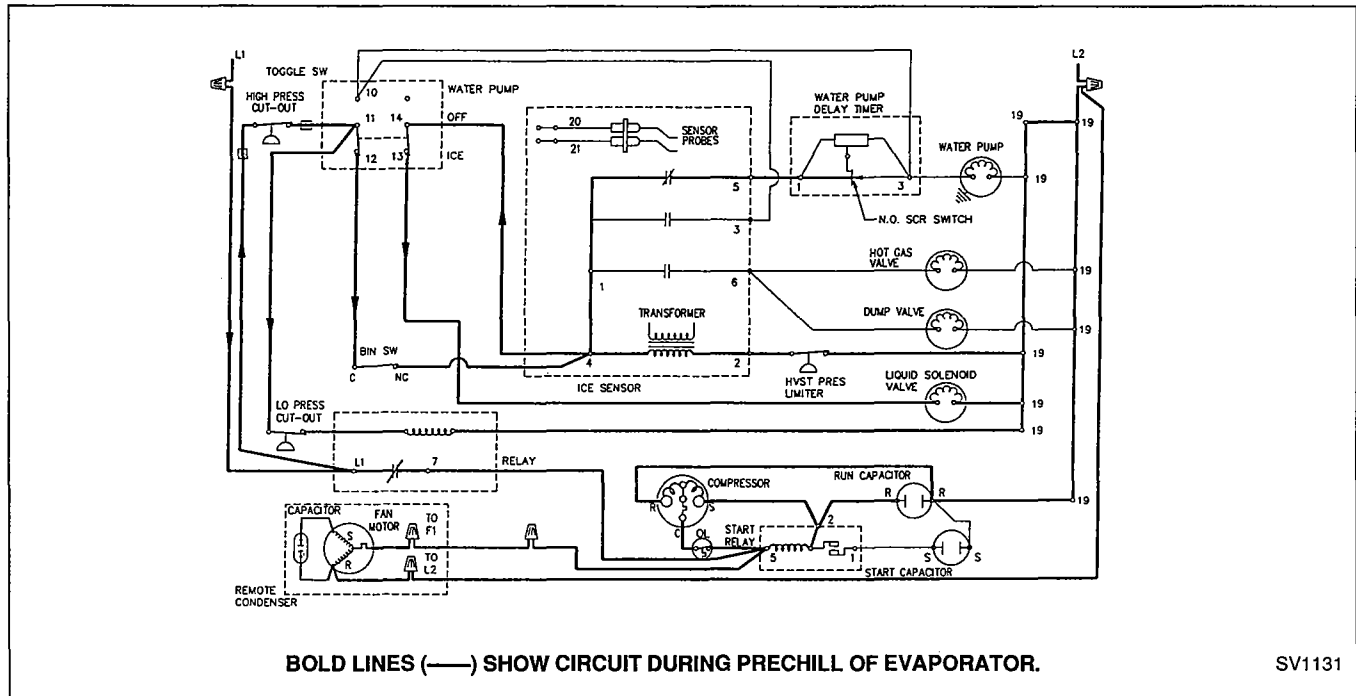
- |    |  |                    |
|----|--|--------------------|
| 1. | Bin switch   | open               |
| 2. | High Pressure Cut-Out control                      | closed             |
| 3. | Toggle switch                                      | ice position       |
| 4. | Primary power to transformer                       | no                 |
| 5. | Ice Sensor Relay                                   | not energized      |
| A) | Ice Sensor Relay contact #6                        | open               |
| 1. | Hot gas solenoid                                   | not energized      |
| 2. | Dump valve solenoid                                | not energized      |
| B) | Ice Sensor Relay contact #3                        | open               |
|    | (water pump circuit during harvest cycle)          |                    |
| C) | Ice Sensor Relay contact #5                        | closed             |
| 1. | Water pump delay timer                             | S.C.R. switch open |
|    | (the timer starts a preset 30-second delay period) |                    |
| D) | Water pump   | off                |
| 6. | 7-Second Delay Relay (contacts between L1 and 7)   | open               |
| A) | Fan motor (air-cooled models)                      | off                |
|    | (fan cycle control may cycle fan on and off)       |                    |
| B) | Compressor   | off                |

# ELECTRICAL SYSTEM SEQUENCE OF OPERATION REMOTE ICE MACHINES

## **FREEZE CYCLE (Prechill of Evaporator)**

At the beginning of the freeze cycle the water pump will not start for 20 seconds.

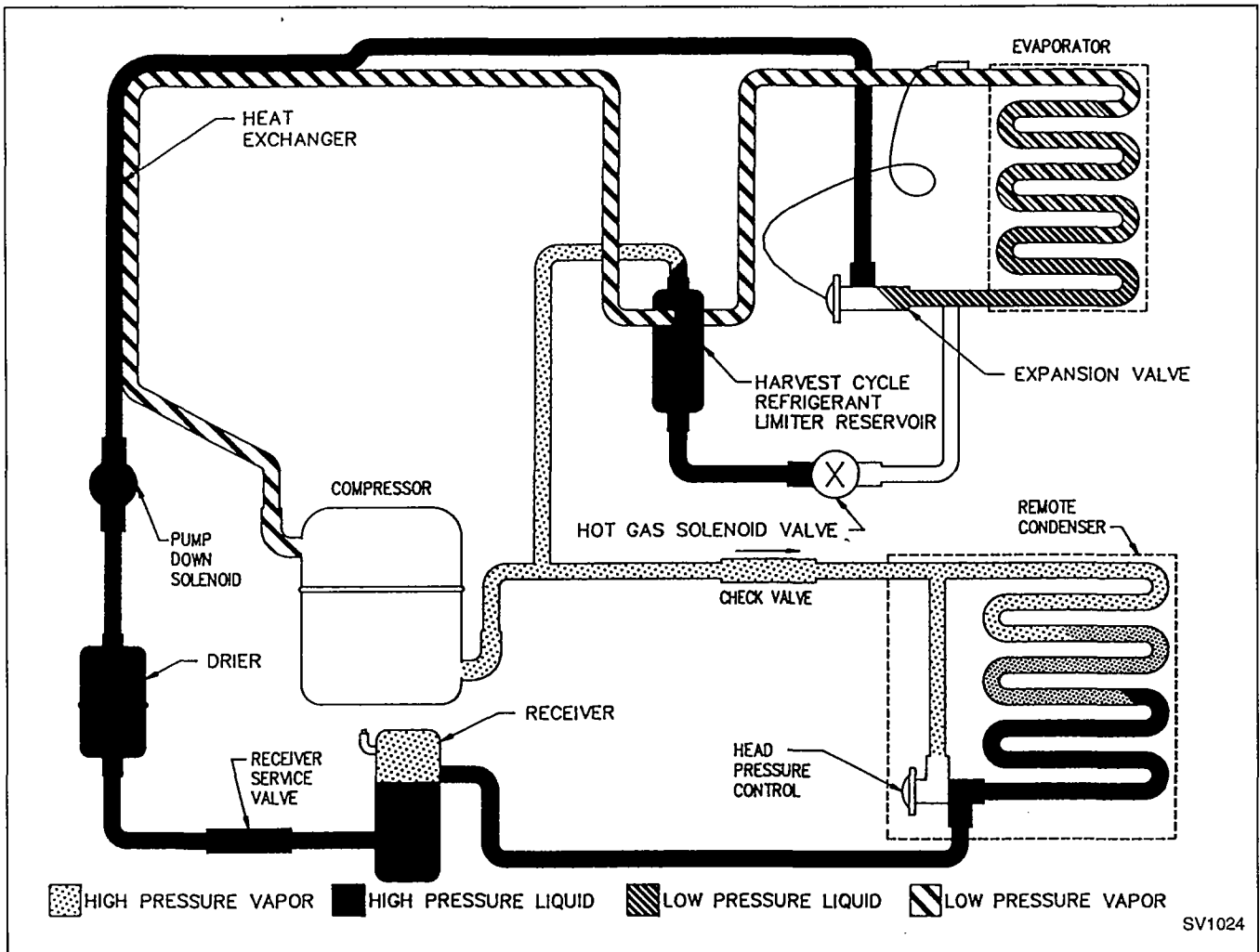
This allows the evaporator to prechill, minimizing build-up of slush in the sump trough.



**FIGURE 28. PRECHILL ELECTRICAL SEQUENCE**

### **Prechill Electrical Sequence**

- |  |                           |
|--|---------------------------|
| 1. Toggle switch . . . . .                                       | ice position              |
| 2. Bin switch . . . . .  | closed                    |
| 3. High pressure cut-out . . . . .                               | closed                    |
| 4. Liquid line solenoid . . . . .                                | energized                 |
| 5. Low pressure cut-out . . . . .                                | closed                    |
| 6. Compressor relay . . . . .                                    | energized/contacts closed |
| A) Compressor . . . . .  | on                        |
| B) Remote fan motor . . . . .                                    | on                        |
| 7. Harvest pressure limiter . . . . .                            | closed                    |
| 8. Power to primary of transformer . . . . .                     | yes                       |
| 9. Ice sensor relay . . . . .                                    | not energized             |
| A) Ice sensor relay contact #6 . . . . .                         | open                      |
| 1. Hot gas valve solenoid . . . . .                              | not energized             |
| 2. Dump valve solenoid . . . . .                                 | not energized             |
| B) Ice sensor relay contact #3 . . . . .                         | open                      |
| (water pump circuit during harvest cycle)                        |                           |
| C) Ice sensor relay contact #5 . . . . .                         | closed                    |
| 1. Water pump delay timer . . . . .                              | S.C.R. switch open        |
| (the timer starts a 20-second delay period)                      |                           |
| D) Water pump . . . . .  | off                       |
| (through ice sensor relay contact #5 and water pump delay timer) |                           |



**FIGURE 29. PRECHILL REFRIGERATION SEQUENCE**

**Prechill Refrigeration Sequence**

There is no water flow over the evaporator during the prechill. The refrigerant absorbs heat (picked up during the harvest cycle) from the evaporator plate. The suction pressure decreases during prechill.

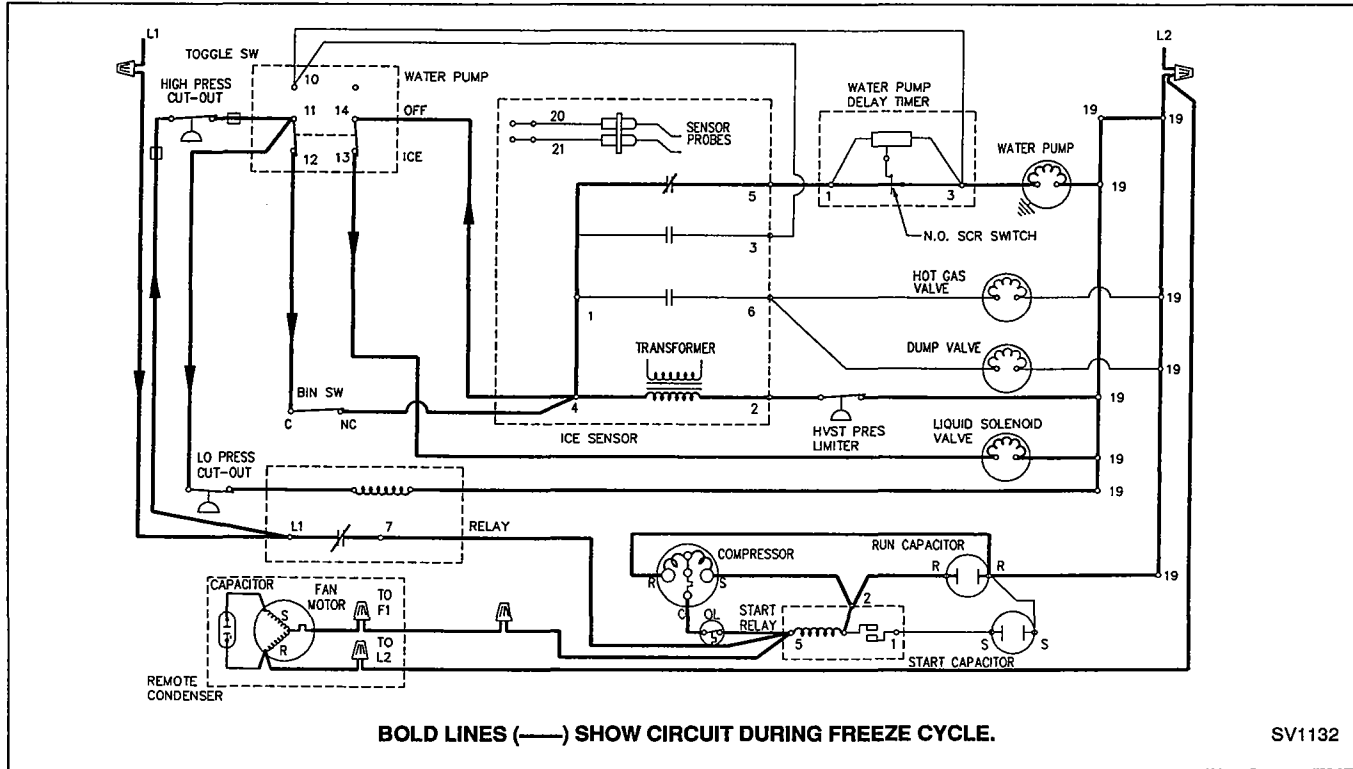
**Prechill Water Flow Sequence**

Water does not flow during the prechill.

## FREEZE CYCLE (Remote Machines)

The freeze cycle begins when the Water Pump Delay Timer completes the 20-second delay and starts the water pump.

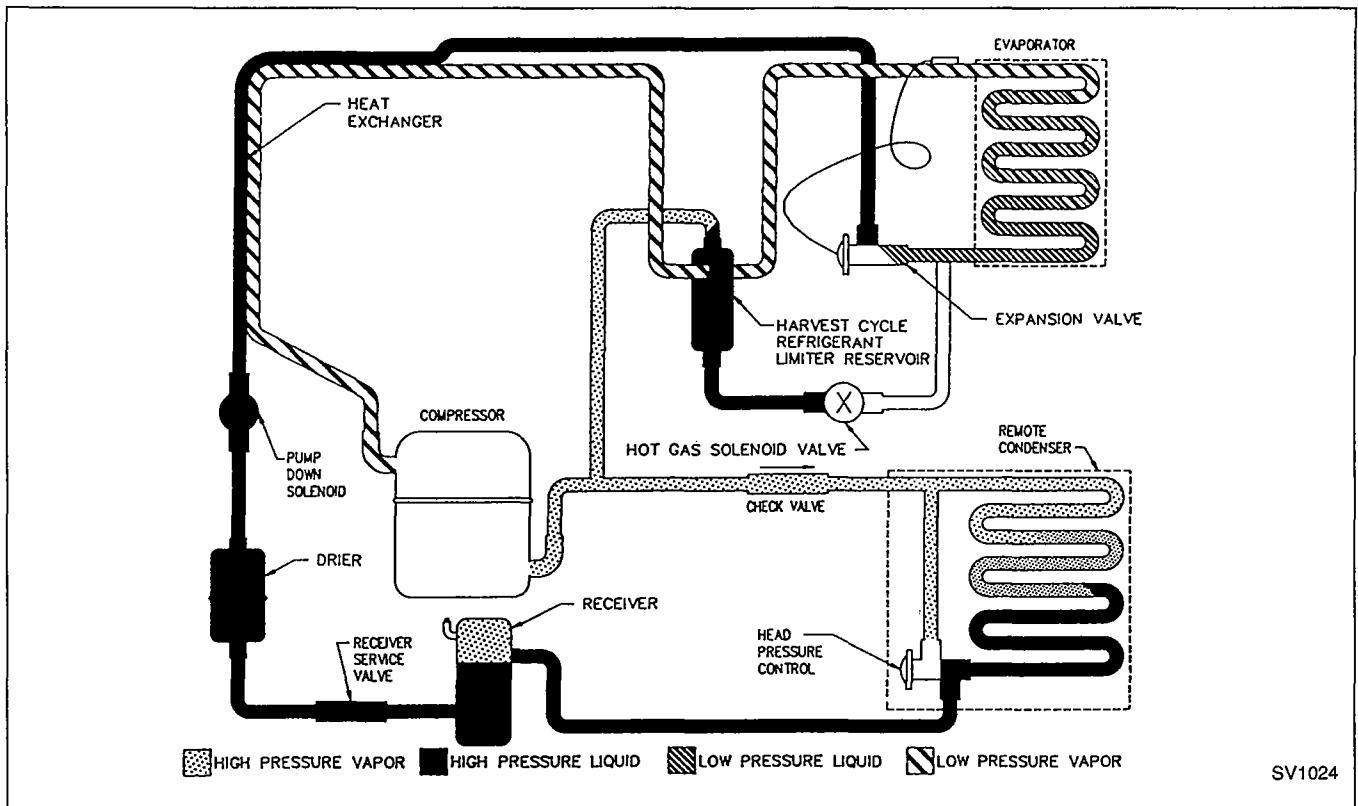
Water flows over the evaporator, forming ice. The freeze cycle will last approximately 13-23 minutes, depending on air and water conditions. (Refer to Cycle Time Chart, page 51.)



**FIGURE 30. FREEZE ELECTRICAL SEQUENCE**

### Freeze Cycle Electrical Sequence

- |  |                           |
|--|---------------------------|
| 1. Toggle switch   | ice position              |
| 2. Bin switch  | closed                    |
| 3. High pressure cut-out   | closed                    |
| 4. Liquid line solenoid  | energized                 |
| 5. Low pressure cut-out  | closed                    |
| 6. Compressor relay  | energized/contacts closed |
| A) Compressor  | on                        |
| B) Remote fan motor  | on                        |
| 7. Harvest pressure limiter                                      | closed                    |
| 8. Power to primary of transformer                               | yes                       |
| 9. Ice sensor relay  | not energized             |
| A) Ice sensor relay contact #6                                   | open                      |
| 1. Hot gas valve solenoid  | not energized             |
| 2. Dump valve solenoid   | not energized             |
| B) Ice sensor relay contact #3                                   | open                      |
| (water pump circuit during harvest cycle)                        |                           |
| C) Ice sensor relay contact #5                                   | closed                    |
| 1. Water pump delay timer  | S.C.R. switch open        |
| (the timer completed a 20-second delay period)                   |                           |
| D) Water pump  | on                        |
| (through ice sensor relay contact #5 and water pump delay timer) |                           |



**FIGURE 31. FREEZE CYCLE REFRIGERATION SEQUENCE**

**Freeze Cycle Refrigeration Sequence**

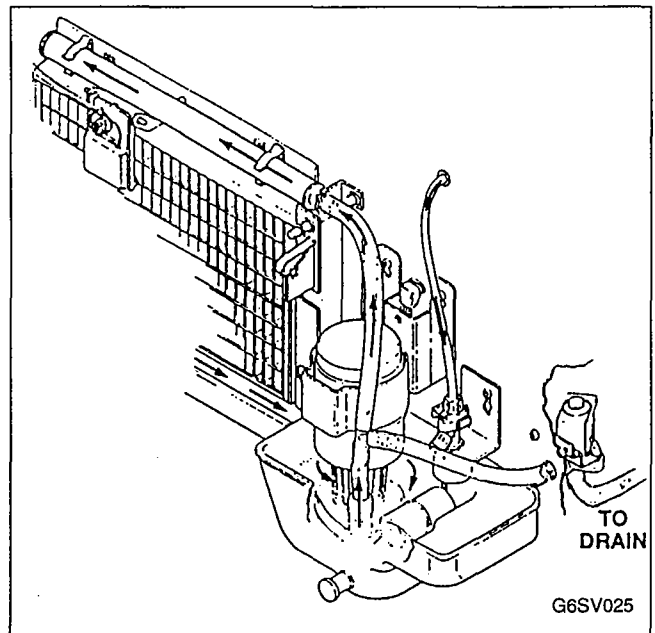
The refrigerant is absorbing heat from water running over the evaporator surface. The suction pressure gradually drops as ice forms.

**Freeze Cycle Water Flow Sequence**

Water from the sump trough is pumped to the distribution tube above the evaporator. It flows evenly over the evaporator to form ice. The float valve maintains proper water level in the sump trough.

**REMOTE FREEZE CYCLE PRESSURES**

Ambient Temp. °F	Head Pressure PSIG	Suction Pressure PSIG
-20 to 50	175-190	44-28
70	190-210	44-28
80	215-255	44-28
90	220-260	44-30
100	245-280	46-32
110	285-320	46-32



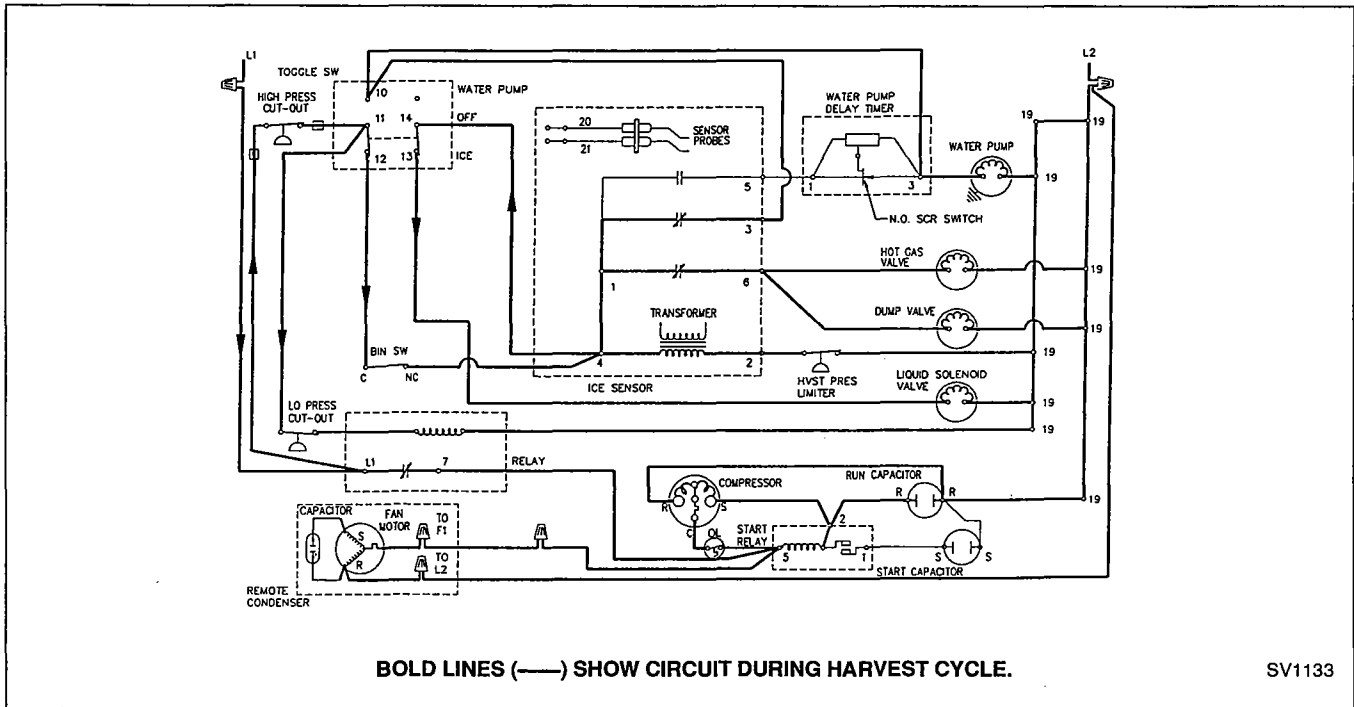
**FIGURE 32. FREEZE CYCLE WATER FLOW SEQUENCE**

## HARVEST CYCLE (Remote Machines)

The harvest cycle begins when water flowing over the ice on the evaporator contacts the probes on the ice thickness control. After a constant 6-10 seconds of water contact, the relay in the unitized sensor board is energized, changing contacts #3, #5 and #6.

Water stops flowing over the evaporator and is pumped

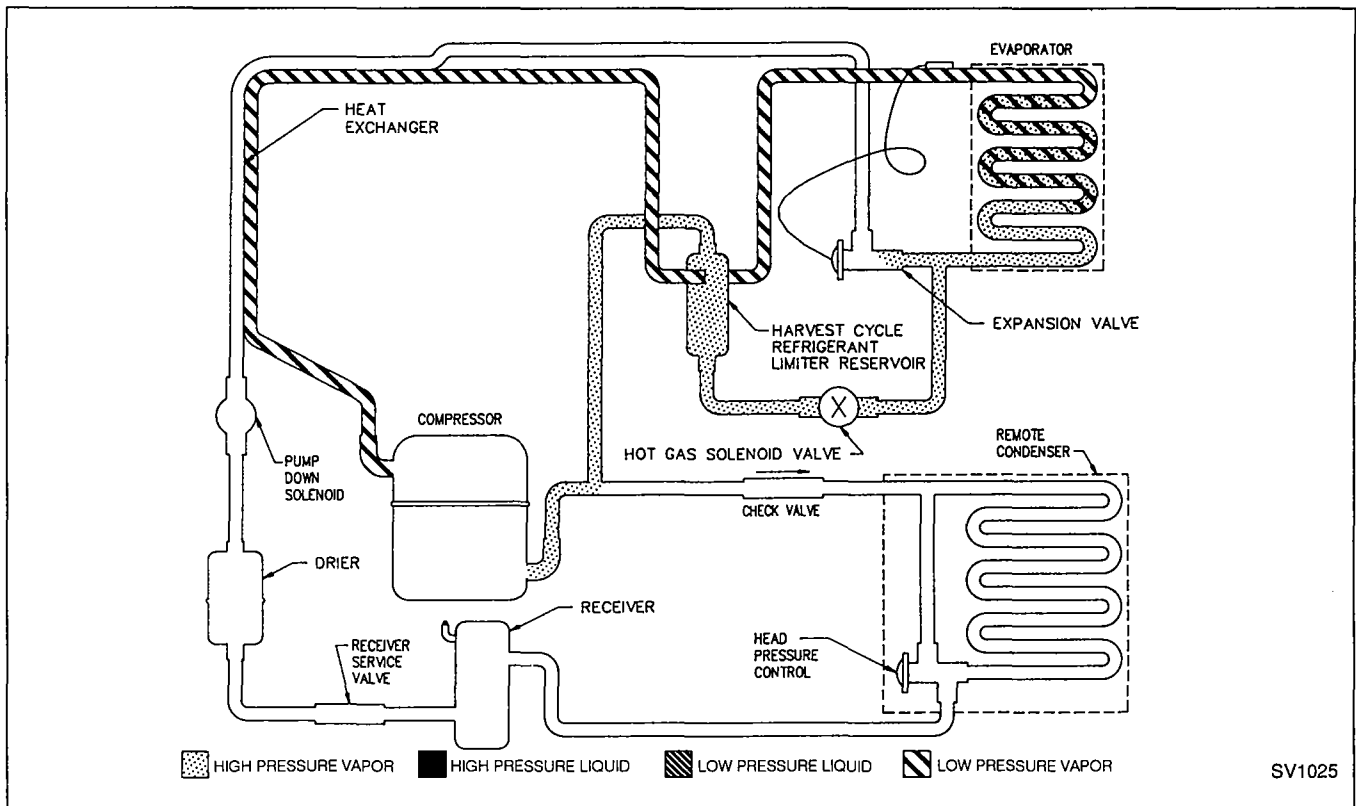
through the dump valve. As hot gas warms the evaporator, the ice cubes slide, as a unit, off the evaporator into the storage bin. The harvest cycle will last approximately 1 to 2 minutes. **Back to freeze cycle prechill:** the falling ice swings the bottom of the water curtain out, momentarily activating (opening) the bin switch. This interrupts the primary power supply at the transformer, de-energizing the ice sensor relay on the unitized sensor board.



**FIGURE 33. HARVEST CYCLE ELECTRICAL SEQUENCE**

### Harvest Cycle Electrical Sequence

- |   |                           |
|---|---------------------------|
| 1. Toggle switch                          | ice position              |
| 2. Bin switch                             | closed                    |
| 3. High pressure cut-out                  | closed                    |
| 4. Liquid line solenoid                   | energized                 |
| 5. Low pressure cut-out                   | closed                    |
| 6. Compressor relay                       | energized/contacts closed |
| A) Compressor                             | on                        |
| B) Remote fan motor                       | on                        |
| 7. Harvest pressure limiter               | closed                    |
| 8. Power to primary of transformer        | yes                       |
| 9. Ice sensor relay                       | energized                 |
| A) Ice sensor relay contact #6            | closed                    |
| 1. Hot gas valve solenoid                 | energized                 |
| 2. Dump valve solenoid                    | energized                 |
| B) Ice sensor relay contact #3            | closed                    |
| (water pump circuit during harvest cycle) |                           |
| C) Ice sensor relay contact #5            | open                      |
| 1. Water pump delay timer                 | S.C.R. switch open        |
| D) Water pump                             | on                        |
| (through ice sensor relay contact #3)     |                           |



**FIGURE 34. HARVEST CYCLE REFRIGERATION SEQUENCE**

**Harvest Cycle Refrigeration Sequence**

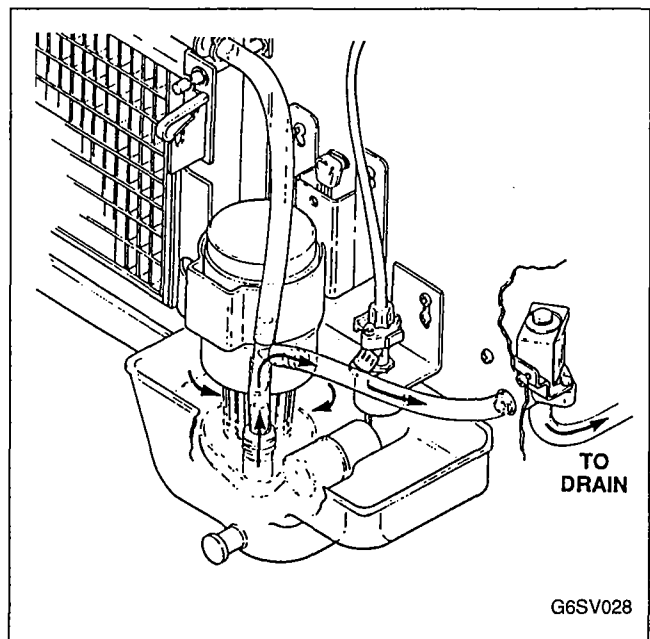
Hot gas flows through the energized hot gas valve heating the evaporator. The hot gas valve is sized to allow the proper amount of refrigerant into the evaporator. This specific sizing assures proper heat transfer without the refrigerant condensing and slugging the compressor.

**Harvest Cycle Water Flow Sequence**

The water from the sump trough is pumped through the energized dump valve and down the drain. The flushing of the minerals after each freeze cycle helps to keep the cubes clear and reduces the frequency of the ice machine cleanings.

**REMOTE HARVEST CYCLE PRESSURES**

Ambient Temp. °F	Head Pressure PSIG	Suction Pressure PSIG
-20 to 50	100-120	60-80
70	100-120	70-90
80	100-120	70-90
90	105-120	70-90
100	105-125	70-90
110	155-185	75-95



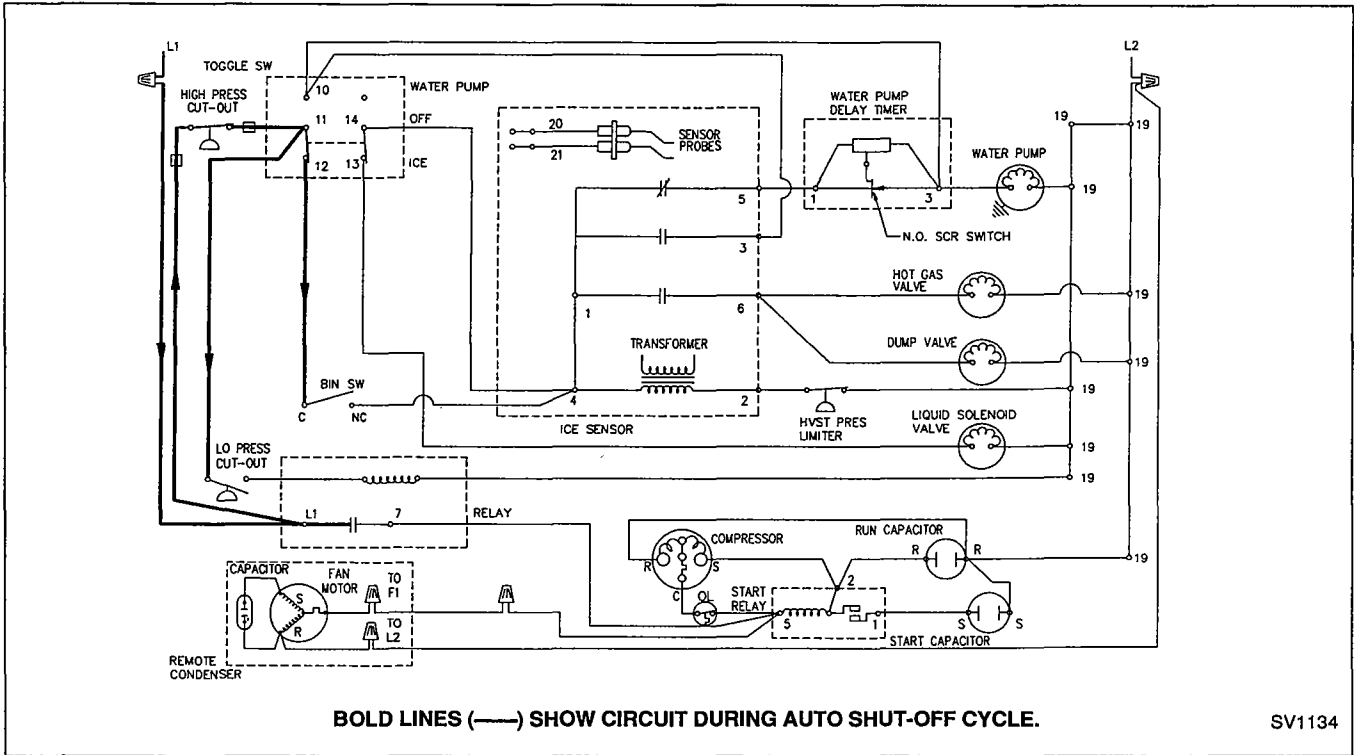
**FIGURE 35. HARVEST CYCLE WATER FLOW SEQUENCE**

## AUTOMATIC SHUT-OFF (Remote Machines) (Full Bin of Ice)

With a full bin of ice the bin switch remains open. This de-energizes the liquid line solenoid valve. The compressor will continue to run and pump down the low side of the ice machine. The low pressure cut-out control opens and de-energizes the compressor relay, and the remote fan motor and compressor shut off.

## AUTO RESTART

The ice machine will stay off until sufficient ice is removed from the bin, allowing the water curtain to return to the normal position and close the bin switch. Closing the bin switch energizes the liquid line solenoid, raising the low side pressure. As the pressure nears 40 psig the low pressure cut-out control closes, which energizes the compressor relay to start the fan motor and compressor.



**FIGURE 36. AUTOMATIC SHUT-OFF ELECTRICAL SEQUENCE**

### Automatic Shut-Off Electrical Sequence

- |  |                             |
|--|-----------------------------|
| 1. Toggle switch . . . . .                   | ice position                |
| 2. Bin switch . . . . .                      | open                        |
| 3. High pressure cut-out . . . . .           | closed                      |
| 4. Liquid line solenoid . . . . .            | not energized               |
| 5. Low pressure cut-out . . . . .            | open                        |
| 6. Compressor relay . . . . .                | not energized/contacts open |
| A) Compressor . . . . .                      | off                         |
| B) Remote fan motor . . . . .                | off                         |
| 7. Harvest pressure limiter . . . . .        | closed                      |
| 8. Power to primary of transformer . . . . . | no                          |
| 9. Ice sensor relay . . . . .                | not energized               |
| A) Ice sensor relay contact #6 . . . . .     | open                        |
| 1. Hot gas valve solenoid . . . . .          | off                         |
| 2. Dump valve solenoid . . . . .             | off                         |
| B) Ice sensor relay contact #3 . . . . .     | open                        |
| (water pump circuit during harvest cycle)    |                             |
| C) Ice sensor relay contact #5 . . . . .     | closed                      |
| 1. Water pump delay timer . . . . .          | S.C.R. switch closed        |
| D) Water pump . . . . .                      | off                         |

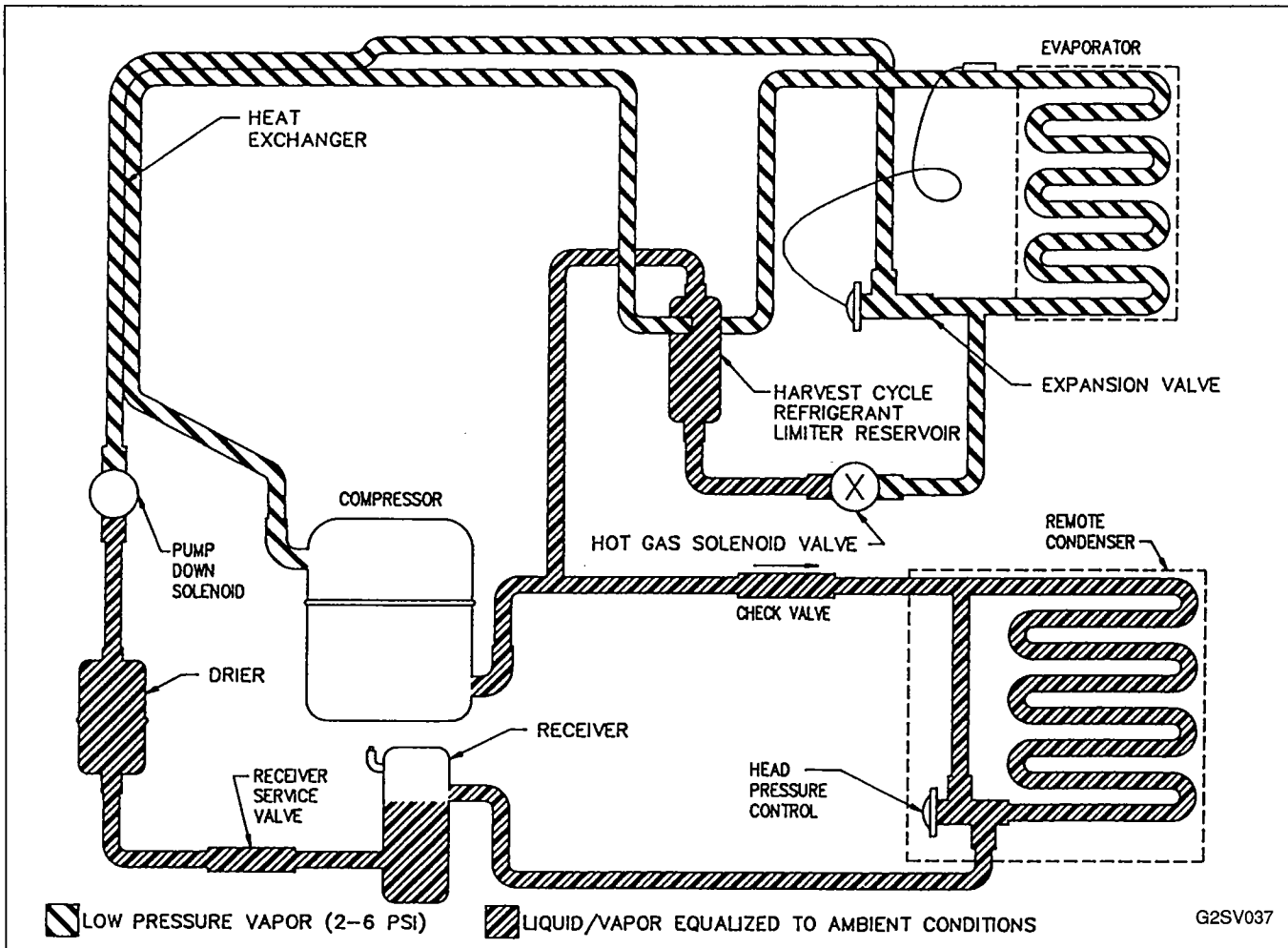
**AUTOMATIC SHUT-OFF  
(Remote Machines)  
(Refrigeration Sequence)**

The liquid line solenoid is de-energized and the compressor continues to run. The compressor pumps refrigerant out of the low side of the ice machine and into the high side past the check valve. The low pressure cut-out control opens when the low side pressure reaches approximately 15 psig. When the cut-out control opens the compressor is de-energized. With the compressor not operating it is protected from refrigerant migration during the off cycle, preventing refrigerant slugging upon start-up.

**IMPORTANT**  
Do not shut down a remote machine at the circuit breaker panel. The machine will not pump down and de-energize the compressor for off cycle protection. Compressor failure may result when the ice machine is restarted.

**AUTOMATIC SHUT-OFF WATER  
FLOW SEQUENCE**

The water system does not operate during the refrigeration shut-off sequence.



**FIGURE 37. AUTOMATIC SHUT-OFF REFRIGERATION SEQUENCE**

# SERVICE DIAGNOSTIC CHART

Symptom	Possible Cause	Corrective Action
Ice machine will not run.	ICE/OFF/WATER PUMP switch. a. Not in ICE position. b. Defective/miswired.  High pressure cut-out control tripped. a. Condenser water pressure low or off (water cooled). b. Condenser water temperature above 90°F (water cooled).  c. Dirty condenser (air cooled). d. Refrigerant overcharge. e. High side refrigerant lines or component plugged. f. Headmaster control valve defective. g. H.P.C.O. control defective. Circuit breaker tripped or blown fuse. Bin switch. a. Out of adjustment. b. Defective. Voltage too low.	Set switch at ICE. Check ICE/OFF/WATER PUMP switch, page 38.  Open water service valve at water condenser inlet. Maintain water supply temperature between 33°F minimum and 90°F maximum. Clean condenser. Evacuate/recharge, page 65. Repair line/change drier.  Check control valve, page 59.  Check control, page 37. Reset circuit breaker or replace fuse.  Check adjustment, page 36. Check bin switch, page 36. Electrical service must not fluctuate more than $\pm 10\%$ .
	<u>Remote Machines Only:</u> Liquid line solenoid valve. a. Defective coil. b. Not opening. Refrigeration problem.  Low pressure cut-out control.	Replace coil, page 62. Replace valve, page 62. Refer to Six-Step Diagnostic Procedure, page 47. Check control, page 42.
Water pump starts before 20-second prechill is completed.	Water pump delay timer. a. Out of adjustment. b. Defective timer.	Adjust timer to 20 seconds. Check timer, page 40.
Water pump does not start after 20 seconds prechill.	Water pump delay timer defective. ICE/OFF/WATER PUMP switch defective. Water pump defective.	Check timer, page 40. Check ICE/OFF/WATER PUMP switch, page 38. Check water pump, page 39.
Compressor cycles intermittently or will not run.	Voltage too low.  Defective start relay. Defective start capacitor. Wiring to compressor.  Defective compressor. 7-second off delay relay defective.	Electrical service must not fluctuate more than $\pm 10\%$ of nameplate voltage. Check relay, page 45. Check capacitor, page 46. Check for loose connection/miswiring or open and replace. Check compressor, page 45. Check delay relay, page 41.

Symptom	Possible Cause	Corrective Action
Compressor cycles intermittently or will not run (continued).	<b>Remote Machines Only:</b> Low pressure cut-out control. Refrigeration problem.  Compressor relay defective.	Check control, page 42. Refer to Six-Step Diagnostic Procedure, page 47. Replace relay.
Fan motor will not start.	Defective fan cycling control (self-contained). Defective fan motor. Defective 7-second off delay relay (self-contained). Defective compressor relay.	Check fan cycling control, page 36.  Check fan motor, page 36. Check delay relay, page 41.  Replace relay.
Ice machine will not cycle into harvest.		Refer to page 43 for Diagnostic Procedures.
Ice machine repeatedly cycles into harvest with little or no ice formation.		Refer to page 44 for Diagnostic Procedures.
Ice machine does not cycle from harvest to freeze when ice falls into bin.	Bin switch out of adjustment. Defective bin switch.	Adjust bin switch, page 36. Check bin switch, page 36.
Water runs over evaporator during harvest cycle.	Drain line too small. Water dump valve defective or dirty.	Drain line must be 1/2" I.D. Refer to Checking and Cleaning Water Dump Valve, page 17.
Ice cubes too large/small.	Ice thickness probe out of adjustment.	Adjust ice thickness probe, page 38.
Shallow or incomplete cubes; incomplete ice fill pattern on evaporator.	Ice thickness probe out of adjustment. Ice machine dirty.  Water filtration. Ice making water inlet supply too warm.  Incorrect incoming water pressure. Leaking water dump valve.  Refrigeration problem.	Adjust ice thickness probe, page 38.  Clean and sanitize ice machine, refer to pages 13 and 17. Replace filters. Maintain water supply temperature between 33°F minimum and 90°F maximum. Water pressure must be 20-80 psig. Refer to Checking and Cleaning Water Dump Valve, page 17. Refer to Six-Step Diagnostic Procedure, page 47.
Ice machine does not release ice or is slow to harvest.	Ice machine dirty.  Air-cooled models — low ambient. Water regulating valve leaking during harvest cycle (water-cooled models). R.T.V. sealant between white plastic and metal evaporator missing. Headmaster control defective (remote).	Clean and sanitize ice machine. Refer to pages 15 and 17. Minimum ambient is 35°F. Clean water regulating valve and condenser.  Reseal with food grade R.T.V. sealant. Check control, page 59.
Low ice capacity.		Refer to Six-Step Diagnostic Procedure, page 47.

# COMPONENT FUNCTION, SPECIFICATIONS AND CHECK PROCEDURES

## BIN SWITCH

### Function

Bin switch operation is controlled by movement of the water curtain (refer to Water Curtain, page 39). It resets ice machine to the freeze cycle by momentarily interrupting power to the transformer board as ice falls from the evaporator. The bin switch also shuts the ice machine off when the bin is full.

### Specifications

Single pole/single throw, normally closed.

#### NOTE

The N.O. terminal is not used.

### Check Procedure

1. Pull water curtain away from evaporator until ice machine shuts off, Figure 38. (Remote machines, wait for ice machine to pump down.)
2. Slowly return curtain to evaporator. Ice machine should restart as bottom edge of water curtain passes just inside edge of water trough. (Remote machines, bin switch energizes Liquid Line Solenoid.)
3. If bin switch adjustment is necessary, adjust as follows:
  - a. Set ICE/OFF/WATER PUMP switch at OFF.
  - b. Slowly pull bottom of water curtain away from evaporator until bin switch clicks, then slowly return curtain toward evaporator.
  - c. If bin switch clicks before water curtain reaches water trough, lengthen the bin switch activating pin, step 4b.
  - d. If bin switch clicks when curtain is too far toward evaporator, shorten the bin switch activating pin.
  - e. Set ICE/OFF/WATER PUMP switch at ICE after adjustment is complete.
4. Bin switch pin adjustment (see Figure 38):
  - a. Loosen brass nut.
  - b. Turn end of pin closest to water curtain counterclockwise to lengthen, clockwise to shorten.
  - c. Tighten brass nut after adjustment and repeat Check Procedure.
5. If bin switch does not operate properly after adjustment, check bin switch with Ohmmeter and/or voltmeter across N.C. and C. terminal while depressing and releasing activating pin. If bin switch does not open and close properly, replace switch.

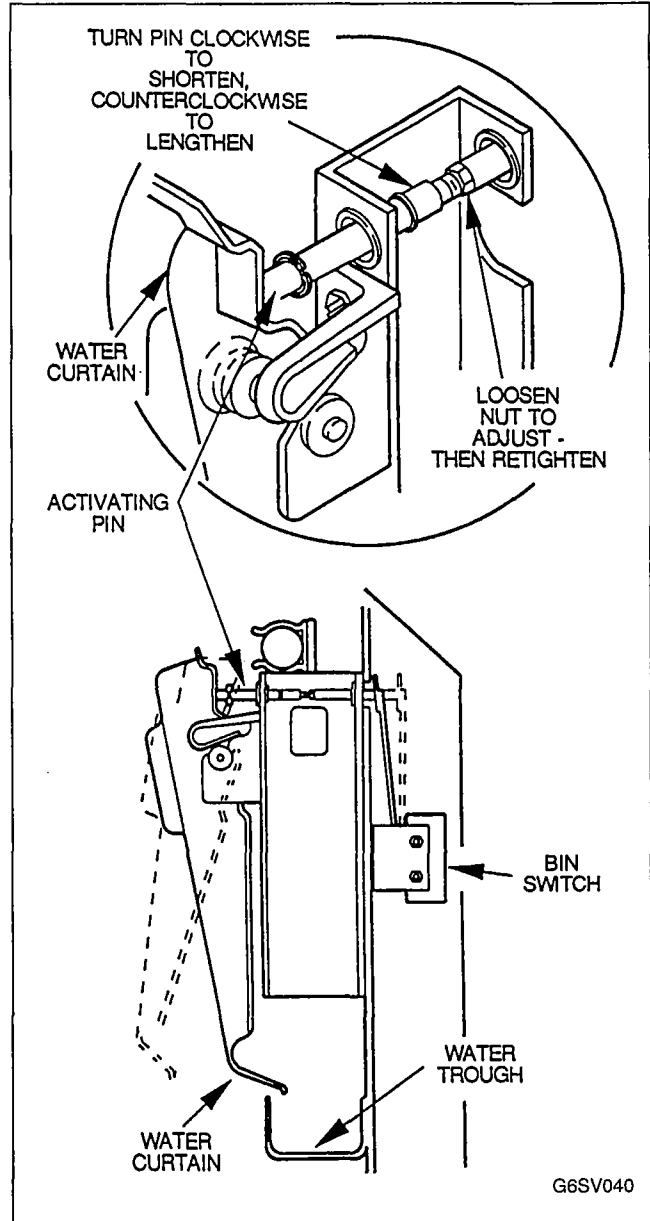


FIGURE 38. BIN SWITCH ACTIVATING PIN ADJUSTMENT

## FAN CYCLE CONTROL (Air-Cooled Models)

### Function

Cycles fan motor on and off to maintain proper operating discharge pressure.

The fan cycle control is a normally closed and opens on a drop in discharge pressure.

## Specifications

Cut-out — 175 psig ( $\pm 5$  psig)

Cut-in — 225 psig ( $\pm 5$  psig)

## Check Procedure

1. Verify fan motor windings are not open or grounded and fan spins freely.
2. Connect manifold gauges to ice machine. Refer to page 60.
3. Hook voltmeter in parallel (across) to the fan cycle control, leaving wires attached.
4. Pressure below 175 psig — read line voltage and fan should be off.

Replace Fan Cycle Control if:  
Control does not operate within range listed above.

## FLOAT VALVE

### Function

Maintains correct water level in water trough.

### Check Procedure

1. Set ICE/OFF/WATER PUMP switch at OFF.

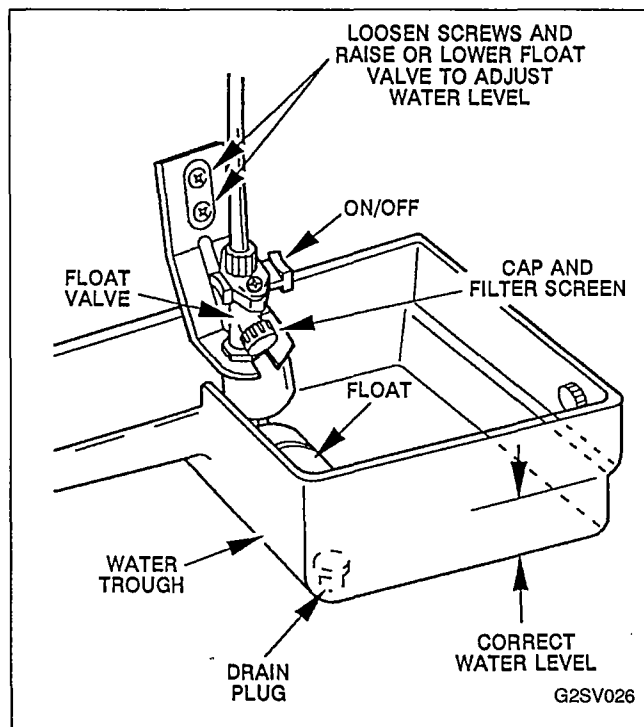


FIGURE 39. FLOAT VALVE CHECK

2. Remove drain plug from trough and allow water to drain. See Figure 39.

3. Reinstall drain plug on trough and allow trough to refill to proper level.

The float valve is factory set to maintain correct water level. If adjustment is necessary, proceed as follows:

- a. Loosen two screws on float valve bracket.
- b. Raise or lower float valve assembly, then tighten screws.
- c. If further adjustment is necessary, carefully bend float arm to achieve correct level.
- d. If float valve cannot be adjusted to maintain correct water level in trough, replace float valve.

## HIGH PRESSURE CUT-OUT CONTROL — H.P.C.O.

### Function

Safety control which turns the ice machine off if subjected to excessive high-side pressure. The H.P.C.O. control is a normally closed control and opens on a rise in pressure.

### Specifications

Cut-out — 440 psig  $\pm 10$ .

Cut-in — manual reset (below 300 psig to reset).

### Check Procedure

1. Set ICE/OFF/WATER PUMP switch at OFF and reset H.P.C.O. (if tripped).
2. Hook voltmeter in parallel (across) to the H.P.C.O. leaving wires attached.
3. Connect manifold gauges. Refer to page 60.
4. Procedures:
  - a. Water-Cooled Machines — Close the water service valve to the water condenser inlet. See Typical Installation illustration, page 5.
  - b. Air-Cooled Machines — Disconnect fan motor.
5. Set ICE/OFF/WATER PUMP switch to ICE.

No water or air flowing through the condenser will cause the H.P.C.O. control to turn the ice machine off because of excessive high pressure. Watch the high-pressure gauge and record the pressure at which the cut-out takes place.

Replace the H.P.C.O. control if:

1. The control will not reset. (Note: High-side pressure must be below 300 psig before resetting.)
2. The control does not open at the specified cut-out point of 440 psig  $\pm 10$ .

## ICE THICKNESS PROBE

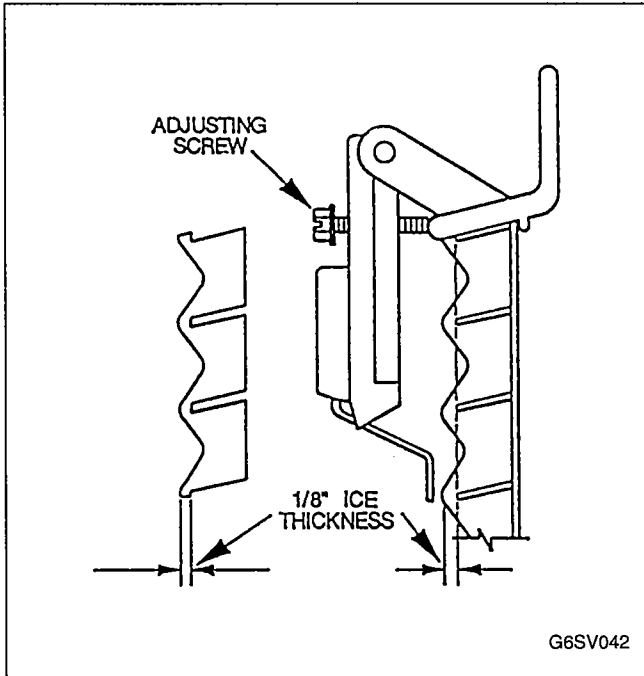
### Function

Maintain correct ice thickness.

### Check Procedure

Verify that wire connections are clean and tight. Inspect bridge connecting the cubes. The ice thickness probe is factory set to maintain 1/8-inch ice thickness. If adjustment is necessary, proceed as follows:

1. Turn adjustment screw (Figure 40) on ice thickness probe clockwise to increase thickness, counter-clockwise to decrease thickness.



**FIGURE 40. ICE THICKNESS CHECK**

### NOTE

Do not turn more than 1/4 turn at a time. Check ice at least two harvest cycles after initial adjustment before adjusting again (if necessary).

2. Ensure ice thickness probe wires and bracket do not restrict movement of probe.
3. If probe does not maintain correct ice thickness, refer to diagnosing Electronic Control Circuitry, page 43.

## ICE/OFF/WATER PUMP TOGGLE SWITCH

### Function

Place ice machine in ICE, OFF, or WATER PUMP mode of operation.

### Specifications

Double pole/double throw, 125V 20A.

### Check Procedure



### WARNING

**DISCONNECT ELECTRIC POWER TO THE ICE MACHINE AT THE ELECTRIC SERVICE SWITCH BOX BEFORE PROCEEDING WITH THE FOLLOWING STEPS.**

1. Inspect switch for correct wiring (Figure 41).
2. Disconnect all wires from toggle switch.
3. Check across switch terminals using a quality, calibrated Ohmmeter for correct readings as follows (replace switch if readings are incorrect):

- a. Switch set at ICE:

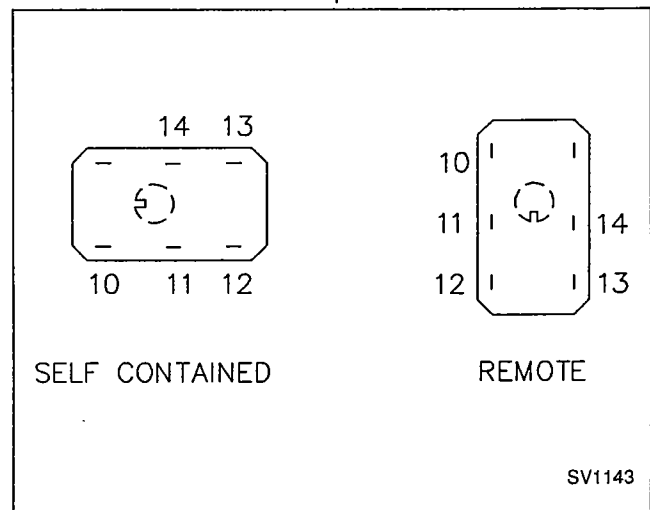
	<u>Switch Position</u>
10-12	Open
11-12	Closed
13-14	Closed

- b. Switch set at WATER PUMP:

	<u>Switch Position</u>
10-11	Closed
11-12	Open
13-14	Open

- c. Switch set at OFF:

	<u>Switch Position</u>
10-11	Open
11-12	Open
13-14	Open



**FIGURE 41. ICE/OFF/WATER PUMP SWITCH CHECK**

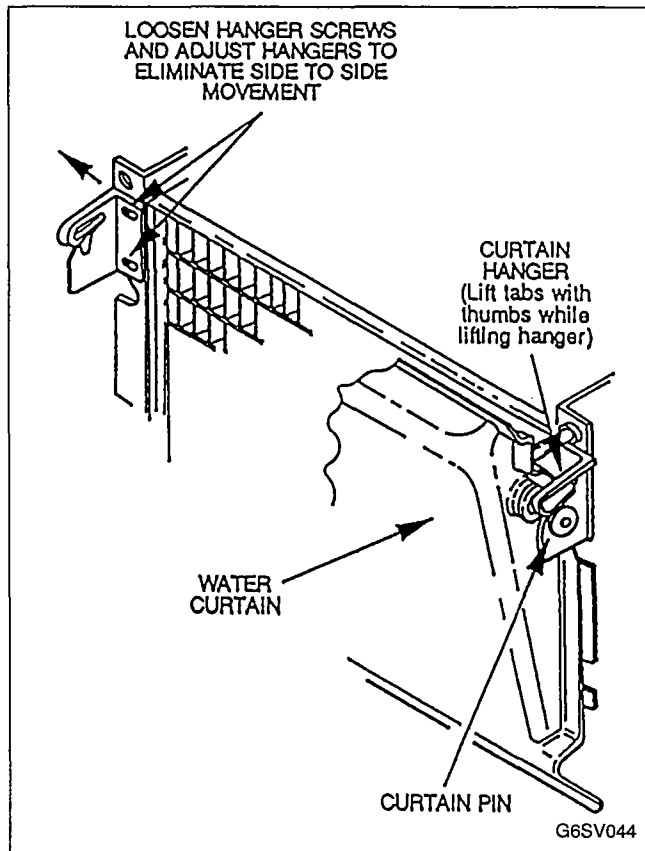
## WATER CURTAIN

### Function

1. Prevent water from splashing into bin.
2. Acts as a lever to depress and release bin switch activating pin (refer to Bin Switch, page 36) as ice falls from the evaporator.

### Check Procedure

1. Pull bottom of water curtain (Figure 42) away from evaporator, then release. Curtain should fall back to evaporator.



**FIGURE 42. WATER CURTAIN CHECK**

2. Move curtain from side to side. There should be little or no movement.

The water curtain is factory set and should require no adjustment. If adjustment is necessary, adjust as follows:

- a. Remove water curtain.
- b. Loosen curtain hanger screws (two per hanger) and slide hangers in or out to prevent side to side movement.
- c. Retighten hanger screws.
- d. Reinstall water curtain.

### NOTE

Water curtain pin heads must be positioned under curtain hanger tabs. Curtain must be centered on evaporator when installed.

## WATER PUMP

### Function

1. Pump water over evaporator during freeze cycle.
2. Pump water through the dump valve and down the drain during harvest cycle.

### Specifications

Refer to ice machine serial number plate for correct voltage and running amps.

### Check Procedure

### NOTE

Water pump runs quietly with no water in water trough.

Set ICE/OFF/WATER PUMP switch at WATER PUMP. If water pump runs with switch at WATER PUMP and does not run with switch set at ICE, the water pump is operating properly. Check water pump delay timer, page 40, for proper operation.

If water pump will not run with switch set at WATER PUMP, check the following procedures:

1. Check for proper line voltage to the ice machine ( $\pm 10\%$ ).
2. Unplug the water pump.
3. Set ICE/OFF/WATER PUMP switch at WATER PUMP and check voltage at water pump electric plug receptacle.
  - a. Line voltage — Replace water pump after verifying pump impeller is not blocked by foreign objects.

### NOTE

For proper ice machine operations replace only with Manitowoc original (OEM) water pump designed and sized specifically for this ice machine.

- b. No voltage — Check high pressure cut-out control, page 37, and ICE/OFF/WATER PUMP switch, page 38.

## WATER PUMP DELAY TIMER

### Function

The water pump delay timer (Figure 7) delays the water pump from starting at the beginning of the freeze cycle, prechilling the evaporator. The timer is adjustable and factory set at 20 seconds.

### Specifications

85-230 volt, 50/60 Hertz.

Normally open (N.O.) silicon rectifier (S.C.R.) switch.

### Check Procedure

#### IMPORTANT

The water pump must be functioning properly to check timer (refer to Water Pump, page 39).

Clip voltmeter leads to terminals No. 1 and No. 3. Keep all wire leads attached. See Figure 43.

### Normal Operational Sequence

First 20 seconds into freeze cycle — Water pump off. line voltage.

After 20 seconds into freeze cycle — Water pump on. 0 volts (1 to 4 volt bleed is OK).

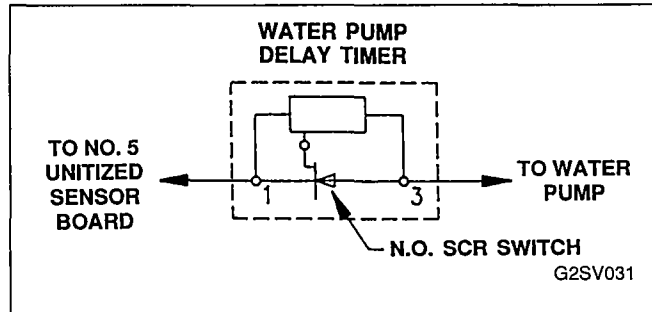


FIGURE 43. WATER PUMP DELAY TIMER CHECK

### WATER PUMP DELAY TIMER FAILURE CHART

Symptom	Voltage Terminals #1 and #3	Cause
Water pump does not run.	Continual line voltage.	S.C.R. switch is failed open and will not close.
Water pump on. No 20-second delay at start of freeze cycle. (May experience slushing in sump trough.)	Continual 0 voltage (or 1-4 volt bleed.)	S.C.R. switch is failed closed and will not open.
Water pump off or running slow.	Approximately 1/2 line voltage.	S.C.R. switch is failed half-wave.

## 7-SECOND OFF DELAY RELAY (Self-Contained Air or Water Cooled)

### Function

1. Prevents interruption of compressor operation when going from the harvest cycle to the freeze cycle.
2. De-energizes the compressor and fan motor (air cooled only) when bin is full or when turned off at toggle switch.

### Specifications

85-230 volt, 50/60 Hertz.

### Check Procedure

Clip voltmeter leads across the normally open (N.O.) relay contacts L1 and #7. Keep all wire leads attached.

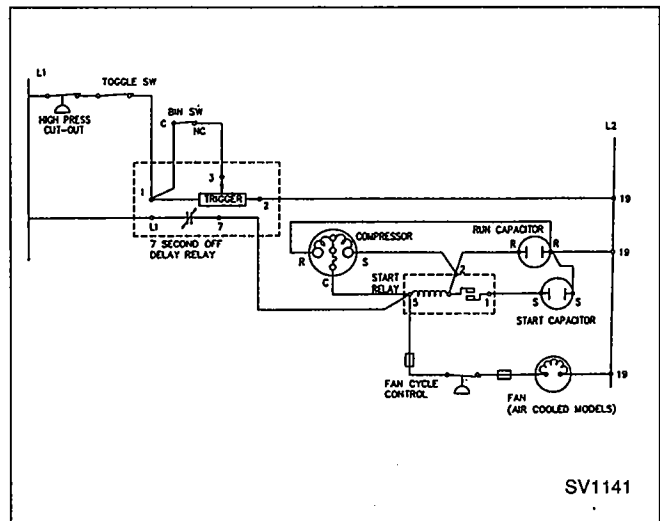


FIGURE 44. 7-SECOND OFF DELAY RELAY

### NORMAL OPERATIONAL SEQUENCE (No Failure)

No Failure	Voltage Reading Terminals L1 and #7
Bin Empty	0 Volts
Bin Full (bin switch tripped for 7 seconds)	Line Voltage

### 7-SECOND OFF DELAY RELAY FAILURE CHART

Symptom	Voltage Terminals L1 and #7	Cause
Compressor and fan (air cooled) will not start with the bin switch closed (empty bin).	Line voltage.	Relay contacts staying open and will not close.
The ice machine functions properly with an empty bin. The compressor and fan (air cooled) will not shut off on a full bin of ice. (Bin switch tripped for 7 seconds.)	0-4 volts.	Relay contacts staying closed and will not open.

## **LOW PRESSURE CUT-OUT CONTROL (Remote Machines)**

### **Function**

1. A drop in suction pressure opens the low pressure cut-out control.
2. Energizes and de-energizes the compressor relay to start and stop the ice machine.

### **Specifications**

Cut-out — 15 psig  $\pm 3$ .

Cut-in — 40 psig  $\pm 3$ .

### **Check Procedure**

1. Connect manifold gauges, page 60.
2. Connect a voltmeter in parallel (across) wires leaving the cut-out control.
3. Set toggle switch to OFF position.
4. The liquid line solenoid valve will de-energize and the suction pressure will begin to decrease. The low pressure cut-out control will open at 15 psig ( $\pm 3$ ). The compressor relay will de-energize and the voltage across the low pressure cut-out control will be "line voltage."
5. Set toggle switch to ICE position. The liquid line solenoid valve will energize and the suction pressure will rise. The low pressure cut-out control will close at 40 psig and the compressor relay will energize. The voltage across the low pressure cut-out control will be "0" volts with the compressor running.
6. Replace the low pressure cut-out control if it does not open and close properly or does not maintain proper settings.

## **HARVEST PRESSURE LIMITER CONTROL**

### **Function**

1. Safety control which cycles the ice machine out of a harvest cycle and returns it to a freeze cycle if suction pressure becomes excessive.
2. The H.P.L. safety control is normally closed and *opens* on a rise in *suction* pressure.

### **Specifications**

Cut-out — 120 psig  $\pm 5$ .

Cut-in — 85 psig  $\pm 5$ .

### **Check Procedure**

1. Connect a voltmeter in parallel (across) the H.P.L. safety control.
2. Connect manifold gauges, page 60.
3. Set toggle switch to OFF position.
4. Pressures:
  - a. When suction pressure rises above 120 psig the H.P.L. safety control must open. The voltmeter must read "line voltage."
  - b. When the suction pressure drops below 85 psig the H.P.L. safety control must close. The voltmeter must read "0" volts.
5. Replace the H.P.L. safety control if it does not open or close properly or does not maintain proper settings.

# DIAGNOSING ELECTRONIC CONTROL CIRCUITRY

## UNITIZED SENSOR BOARD

The ice machine uses a unitized sensor board with a plug-in ice thickness probe to control the ice thickness by initiating the harvest cycle.

### Function

1. A relay energizes or de-energizes the electrical components during the harvest cycle.
2. Electronics sense when the water is in contact with the ice thickness control probe.
3. A 6- to 10-second timer ensures that the water flowing over the evaporator completes an electrical circuit through the ice thickness control probe. This means the water must be in constant 6- to 10-second contact (not "splashing") with both probes before the ice machine cycles into harvest.
4. A safety timer ensures the ice machine does not remain in the harvest cycle for longer than 4 to 5 minutes.

**CAUTION**  
THESE PROCEDURES MUST BE PERFORMED BY A QUALIFIED TECHNICIAN.

Do not make adjustments or turn the ice machine off until the malfunction is identified. The problem may be intermittent and you may lose the opportunity to make the checks while it is malfunctioning.

Follow the systematic approach throughout the diagnosis and write down information as it is collected. This will keep you organized.

### A. POSSIBLE PROBLEM: ICE MACHINE WILL NOT GO INTO HARVEST

**NOTE**  
These procedures require the use of a jumper wire with clip ends attached.

Step 1: Check primary voltage at transformer terminals 4 and 2 on board.

Does voltmeter indicate line voltage ( $\pm 10\%$ )?

IF NO: Check for correct wiring and loose or corroded connections. Also follow control circuitry to check components wired in series with

terminals 4 and 2. Remote machines — Check Harvest Pressure Limit Control, page 42.

Do not proceed until line voltage is restored.

IF YES: Proceed to Step 2.

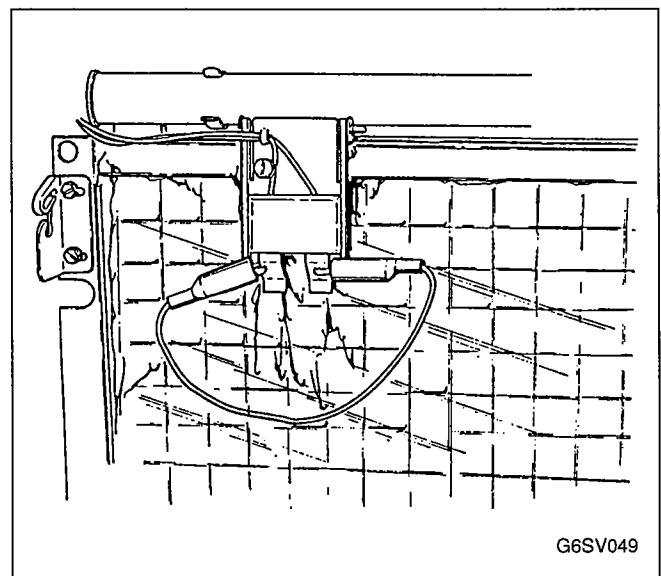
Step 2: Clip the leads of the jumper wire to the ice thickness control probe, Figure 45.

Does the ice machine go into the harvest cycle?

IF NO: The ice machine still will not harvest. Proceed to Step 3.

IF YES: The entire control circuitry is functioning properly. Check the following:

- a. Ice thickness probe adjustment, page 38.
- b. Ice thickness probe has scale build-up acting as an insulator. Clean probe.
- c. The water to the ice machine may not offer a low enough resistance across the probes for proper operation. To check, put a small amount of salt into water trough. This will lower the resistance level of the water. If the ice machine goes into harvest after putting salt into the water trough, order Resistor Kit, part number 76-2266-3, from your local Manitowoc Distributor. Install resistor kit across terminals 20 and 21. The ice machine will now operate properly.



**FIGURE 45. JUMPER WIRE CONNECTED TO PROBES**

Step 3: Disconnect wires from terminals 20 and 21 on board. Connect jumper wire to terminals 20 and 21, Figure 46.

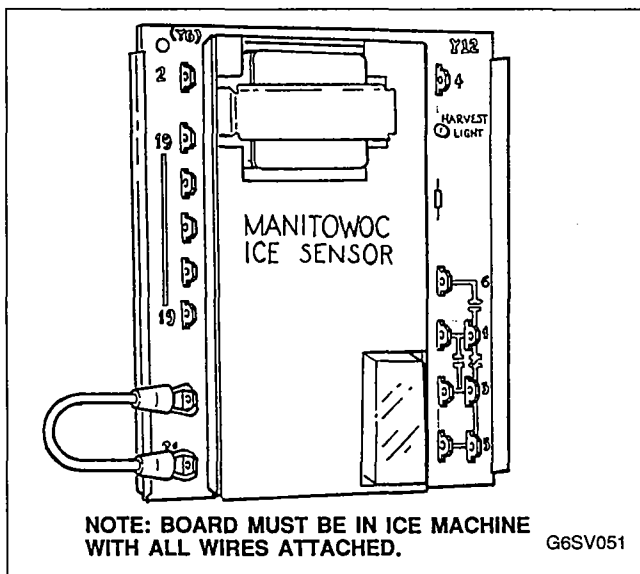
Does the ice machine go into the harvest cycle?

IF NO: Install new unitized sensor board.

**IMPORTANT**

Failure to check primary voltage (Step 1) can result in a misdiagnosis.

IF YES: The ice thickness probe is the cause of the malfunction. The ice thickness probe may simply be dirty. Clean the probe before replacing.



**FIGURE 46. UNITIZED SENSOR BOARD**

**B. POSSIBLE PROBLEM:  
ICE MACHINE PREMATURELY  
GOES INTO HARVEST WITHOUT  
ICE FORMATION**

Step 1: Check primary voltage at transformer terminals 4 and 2 on board.

Does voltmeter indicate line voltage ( $\pm 10\%$ )?

IF NO: Check for correct wiring and loose or corroded connections. Also follow control circuitry to check components wired in series with terminals 4 and 2. Remote Machines — Check Harvest Pressure Limit Control, page 42.

Do not proceed until line voltage is restored.

IF YES: Proceed to Step 2.

Step 2: Disconnect wires on terminals 20 and 21 on unitized sensor board. Activate bin switch to cycle ice machine into the freeze cycle.

Does the ice machine stay in the freeze cycle?

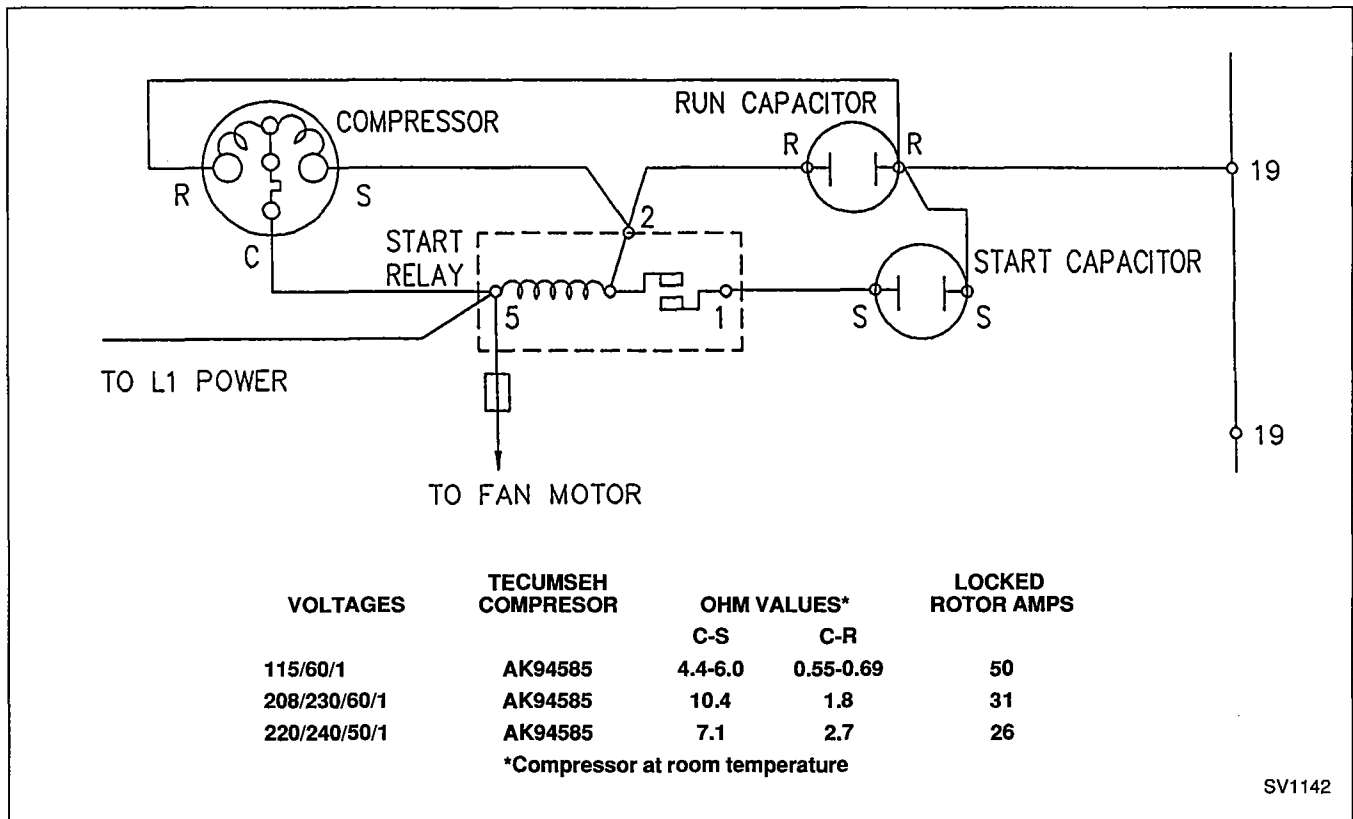
IF NO: Ensure there is no moisture between terminals 20 and 21 on board. If no moisture, install new unitized sensor board.

**IMPORTANT**

Failure to check primary voltage (Step 1) can result in a misdiagnosis.

IF YES: The ice thickness probe is causing the malfunction. The ice thickness probe may simply be dirty. Clean the probe before replacing.

# DIAGNOSING COMPRESSOR AND START COMPONENTS ELECTRICALLY



**FIGURE 47. COMPRESSOR AND START COMPONENTS SCHEMATIC**

Perform the following tests, in sequence, using a quality, calibrated volt-ohmmeter.

1. Check primary voltage to ice machine at time of compressor start-up. Voltage should be  $\pm 10\%$  of nameplate reading.
2. Verify the following control components are in the closed position:
  - Bin Switch, page 36.
  - High Pressure Cut-Out Control, page 37.
  - ICE/OFF/WATER PUMP Switch, page 38.
  - 7-Second Off Delay Relay (self-contained), page 41.
  - Compressor Relay (remotes).

- b. Terminals 1 and 2 (contact normally closed).  
No continuity — replace relay.  
Continuity — relay OK.
- c. Terminals 2 and 5.  
No continuity — replace relay.  
Continuity — relay OK.
4. Continuity check of compressor:

**NOTE**  
Compressor must be at room temperature.

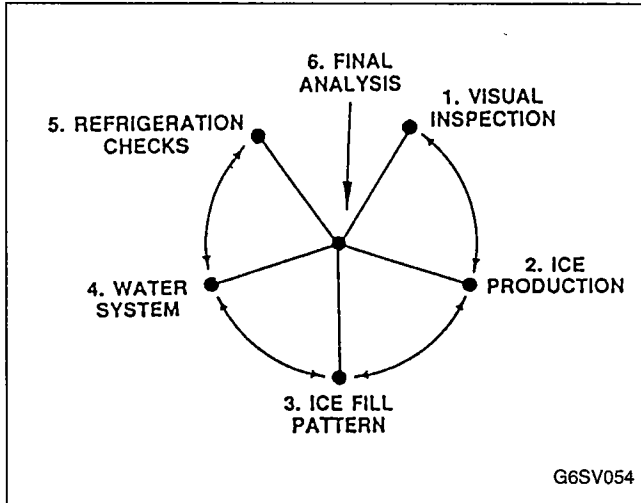
**⚠ WARNING**  
**DISCONNECT ELECTRIC POWER TO THE ICE MACHINE AT THE ELECTRIC SERVICE SWITCH BOX BEFORE PROCEEDING WITH THE FOLLOWING STEPS.**

3. Continuity check of start relay (RX10,000 scale):
  - a. Disconnect wires from start relay. (If relay is being removed, keep it upright.)
  - b. Terminal C to Terminal R.  
Continuity — see step e.  
No continuity — open run winding. Replace compressor.
  - c. Terminal C to Terminal S.  
Continuity — see step e.  
No continuity — open start winding. Replace compressor.
  - d. Terminal C to shell of compressor.  
Continuity — compressor grounded. Replace compressor.  
No continuity — compressor not grounded.

- e. Check winding resistance against values given in chart. The resistance values from C-R and C-S added together should equal the reading from S to R.
5. Capacitor check (run and start):
- a. Capacitors may show visual evidence of failure, such as a bulged terminal end or a ruptured membrane. However, *do not* assume a capacitor is good just because there are no visual signs of failure.
  - b. An effective test is to disconnect leads to the capacitor in the ice machine and connect them to a good capacitor.
- c. Use of a capacitor analyzer is recommended when checking a suspect capacitor. Follow instructions supplied with capacitor analyzer.
  - d. If all of the capacitor tests prove satisfactory and the compressor still fails to start:
    - 1) Replace start relay.  
The new relay eliminates any faulty electrical characteristics such as improper pick-up or drop-out, which cannot be determined by the tests.
    - 2) If new relay fails to correct the problem, the compressor can be considered inoperative because of internal defects. Replace compressor.

# REFRIGERATION AND OTHER NON-ELECTRICAL PROBLEMS

## INTRODUCTION TO THE SIX-STEP DIAGNOSTIC PROCEDURE



**FIGURE 48. SIX-STEP DIAGNOSTIC PROCEDURE**

The Six-Step Procedure (Figure 48) is designed to increase the accuracy of your service call, while decreasing the time required to identify any problems.

Refrigeration components will react and try to compensate for nonrefrigeration component problems. By following this procedure step by step, problems that affect the refrigeration sequence can be identified without needless changing of components.

Each of the six steps have several items to check before proceeding to the next step. Follow each step carefully as the problem may be identified prior to the completion of all six steps.

Step 6 requires the use of information gathered in the previous steps. Write down information as you collect it and record it on the Refrigeration Component Diagnostic Chart, page 58. This will keep you organized and simplify the 6th step of determining the malfunction.

### NOTE

Do not make adjustments or turn the ice machine off until you have identified the malfunction. The problem may not repeat itself.

## STEP 1 — VISUAL INSPECTION

Talk to the ice machine user to identify the perceived problem(s). The user's information could help you start in the right direction and may be a determining factor in your final diagnosis.

Following are a few questions to consider when talking to the ice machine user:

- When is the ice machine malfunctioning? (Night, day, all the time, during freeze cycle, harvest cycle, etc.)

- When do you notice low production? (One day a week, every day, weekends, etc.)
- Can you describe exactly what the ice machine seems to be doing?
- Has anyone been working on the ice machine?
- Were items such as boxes obstructing air flow moved from around the ice machine before you arrived?

### EQUIPMENT VISUAL INSPECTION

(Record Your Findings on Refrigeration Component Diagnostic Chart, Page 58)

Possible Problem	Actual Finding	Corrective Measure
1. Ice machine not properly installed.		Reinstall in accordance with installation manual.
2. Air temperatures/air flow restrictions, etc.		Reinstall in accordance with installation manual.
3. Air space clearances at back and sides of ice machine.		Must have a minimum of 5 inches clearance around back and sides of machine.
4. Ice machine not level side-to-side, back-to-front.		Level machine.
5. Remote condenser dirty.		Clean condenser.
6. Ice machine not on separate fused electrical circuit.		Install electrical in accordance with installation manual.
7. Drains not run separate and/or vented.		Run drains separate and vent according to installation manual.
8. Water filtration restricted (if used).		Install new water filter.

#### NOTE

Steps 2, 3 and 4 can be completed in conjunction with each other. Be careful not to interfere with the ice production check.

## STEP 2 — ICE PRODUCTION

The amount of ice a machine produces is in direct relationship to water and air temperatures. This means an ice machine produces more ice in a 70°F room with 50°F water than in a 90°F room with 70° F water.

### ICE PRODUCTION CHARTS (Lbs. of Ice per 24 Hours) (Regular cube size derate 7%)

#### Water-Cooled

Air Temp. °F	Water Temp. °F		
	50	70	90
70	435	390	340
80	425	385	335
90	415	380	330
100	410	375	325

#### Air-Cooled

Air Temp. °F	Water Temp. °F		
	50	70	90
70	450	400	350
80	390	360	320
90	350	320	290
100	310	280	260

#### Remote Machines

Air Temp. °F	Water Temp. °F					
	50		70		90	
	*	#	*	#	*	#
-20 to 70	420	410	380	370	340	330
90	400	390	360	350	320	310
100	380	370	340	330	300	290
110	340	330	310	300	280	270

Based on 70°F air at ice machine

Condensers: \* AC0496B  
# DC0496A

These figures are based on a clean, properly maintained ice machine running continually for a 24-hour period, with an average ice weight of 4.125 lb. to 4.75 lb. per harvest.

Use the following to check and compare ice production:

#### IMPORTANT

Water curtain must be in place to assure no water is being lost while checking ice production.

1. Condenser inlet air temperature \_\_\_\_\_
2. Water inlet temperature (taken at float outlet) \_\_\_\_\_
3. The published 24-hour ice production at the above conditions: \_\_\_\_\_ lb./24 hours

#### OPERATING CONDITIONS

1. Freeze time \_\_\_\_\_ + harvest time \_\_\_\_\_  
= \_\_\_\_\_ total cycle time
2.  $1440 \div$  total cycle time \_\_\_\_\_  
= \_\_\_\_\_ cycles/day
3. Weight 1 harvest \_\_\_\_\_ x cycles/day \_\_\_\_\_  
= \_\_\_\_\_ lb./24 hours

#### ICE PRODUCTION CHECK

Times are in minutes.

Example: 1 min. 15 sec. convert to 1.25 min.  
 $15 \text{ sec.} \div 60 \text{ sec.} = .25 \text{ min.}$

Weights are in pounds.

Example: 4 lb. 2 oz. convert to 4.125 lb.  
 $2 \text{ oz.} \div 16 \text{ oz.} = .125 \text{ lb.}$

Compare your findings in the Ice Production Check to published specifications in Operating Conditions. Record your findings on Refrigeration Diagnostic Chart, page 58.

- A. Ice Production OK:  
Determine if another ice machine is needed, more storage capacity, or if moving existing equipment to lower load conditions will meet the customer's needs. (Contact local Manitowoc Distributor for options and accessories available.)
- B. Low Ice Production:  
Record your findings on the Refrigeration Diagnostic Chart, page 58, and continue through the Six-Step Procedure.

### STEP 3 — ICE FILL PATTERN

The fill pattern on the evaporators is normal when the ice thickness is a uniform 1/8 inch from top to bottom and side to side. (The ice bridge is the inter-connecting waffle between the cubes. Refer to page 38.) The water should freeze on the entire evaporator at the same time. Ice forming on the bottom of an evaporator then working its way up to the top is not normal and must be noted as "thin on top and thick on bottom."

**IMPORTANT**

The water curtain must be in place to ensure no water is being lost while checking ice fill pattern.

Examples of ice fill patterns:

- Normal ice fill — uniform 1/8-inch bridge thickness on entire evaporator surface.
- Thick on top and thin on bottom.
- Thin on top and thick on bottom.
- Spotty ice fill (i.e., corner not filling, etc.).

Record your findings on the Refrigeration Diagnostic Chart, page 58. (Step 3 actual findings column of chart.)

### STEP 4 — WATER SYSTEM

Water related problems in ice machines often have the same symptoms as a refrigeration system malfunction.

Water area failures must be identified and eliminated prior to changing of refrigeration components. An example is a water dump valve leaking during the freeze cycle and a starving TXV. The characteristics of both failures are similar.

### CHECK WATER RELATED PROBLEMS

(Record Your Findings on Refrigeration Component Diagnostic Chart, Page 58.)

Possible Problem	Actual Finding	Corrective Measure
1. Water area (evaporator) dirty.		Clean.
2. Water inlet pressure not between 20-80 psi.		Install water regulator valve or increase water pressure.
3. Incoming water supply temperature must be 35°F to 90°F.		Too hot — check hot water line check valves in other store equipment.
4. Water filter restricted (if used).		Replace filter.
5. Dump valve malfunctioning.		Clean dump valve. Replace as needed, page 17.
6. Vent tube not installed on water outlet drain.		See Installation Manual.
7. Water trough hoses leaking water.		Install properly or replace.
8. Water float valve stuck open or out of adjustment.		Readjust float, page 37.
9. Water freezing behind evaporators.		Check water flow.
10. Water freezing between white plastic extrusions and evaporator.		Seal with food-grade silicone (RTV) adhesive.
11. Water flow uneven across evaporator.		Clean ice machine. Check water flow rate.

## STEP 5 — REFRIGERATION

The refrigeration section requires taking several checks to gather information.

### NOTE

Only proceed to Refrigeration System Step 5 after Steps 1-4 have been thoroughly checked and a final diagnosis could not be determined.

### OPERATIONAL PRESSURE CHART

Ambient Temp. °F	Freeze Cycle		Harvest Cycle	
	Head Pressure PSIG	Suction Pressure PSIG	Head Pressure PSIG	Suction Pressure PSIG
<b>Water-Cooled</b>				
50	235-245	42-32	140-165	80-100
70	235-245	42-32	140-165	80-100
80	235-245	44-32	150-175	80-100
90	235-245	44-32	170-200	85-105
100	235-245	46-32	190-210	85-105
<b>Air-Cooled</b>				
50	175-225	44-26	120-145	60-80
70	175-225	46-26	125-150	65-85
80	210-260	48-28	140-160	75-95
90	250-300	48-30	160-180	90-110
100	300-350	48-32	200-240	110-130

### Remote Machines

Ambient Temp. °F	Freeze Cycle		Harvest Cycle	
	Head Pressure PSIG	Suction Pressure PSIG	Head Pressure PSIG	Suction Pressure PSIG
-20 to 50	175-190	44-28	100-120	60-80
70	190-210	44-28	100-120	70-90
80	215-255	44-28	100-120	70-90
90	220-260	44-30	100-120	70-90
100	245-280	46-32	105-125	70-90
110	285-320	46-32	155-185	75-95

## CYCLE TIME CHART

### NOTE

To calculate total cycle time, add harvest time to freeze time listed in charts.

Ambient Temp. °F	Freeze Time			Harvest Time ^
	Water Temp.			
	50°F	70°F	90°F	
<b>Water-Cooled</b>				
70	12.0-14.0	13.5-16.0	16.0-18.5	1-2
80	12.5-14.5	14.0-16.0	16.0-19.0	
90	13.0-15.0	14.0-16.5	16.5-19.0	
100	13.0-15.0	14.0-16.5	16.5-19.3	
<b>Air-Cooled</b>				
70	12.0-14.0	13.0-15.5	15.5-18.0	1-2
80	14.0-16.0	15.0-17.5	17.0-20.0	
90	15.5-18.0	17.0-20.0	20.0-22.0	
100	17.5-20.0	19.5-23.0	21.0-25.0	

### Remote Machines

Condenser Ambient Temp. °F	Freeze Time			Harvest Time ^
	Water Temp.			
	50°F	70°F	90°F	
-20 to 70	12.5-15.0	14.0-16.5	16.0-18.5	1-2
90	13.0-15.5	15.0-17.5	17.0-20.0	
100	14.0-16.5	16.0-18.5	18.0-21.0	
110	16.0-18.5	17.5-20.0	19.5-23.0	

### Record Pressure of Freeze and Harvest Cycles

Freeze Cycle	Discharge	Suction
<ol style="list-style-type: none"> <li>One minute to freeze</li> <li>Middle of freeze</li> <li>End of freeze</li> </ol>		
Harvest Cycle		
<ol style="list-style-type: none"> <li>Start of harvest</li> <li>Middle of harvest</li> <li>End of harvest</li> </ol>		

**Step 5A — Analyze Discharge Pressure**

Using the Operational Pressure Chart, page 51, determine if the discharge pressure is correct for the ambient temperature the ice machine is located in.

A. If discharge pressure is within normal range, proceed to Step 5B to analyze suction pressure.

B. If discharge pressure is not within normal range, refer to the appropriate chart below.

C. Record findings on Refrigeration Diagnostic Chart, page 58.

**DISCHARGE PRESSURE HIGH**

Eliminate the possible problems in the order listed on chart and follow appropriate corrective measures.

Possible Problem	Actual Finding	Corrective Measure
1. Load conditions high (air/water temperatures).		Refer to Installation Instructions.
2. Dirty condenser.		Clean.
3. Water regulating valve (water-cooled condenser): a. Too small supply water line. b. Out of adjustment. c. Defective regulating valve.		Replace with proper size line. See proper adjustment, page 63. Replace.
4. Fan motor/fan cycling switch defective.		Diagnose control, page 36.
5. Restriction in high side lines.		Repair, see Evacuation/Recharging Procedures, page 65.
6. Improper refrigerant charge.		Refer to Evacuation/Recharging Procedures, page 65.
7. Noncondensables in system.		Refer to Evacuation/Recharging Procedures, page 65.

**DISCHARGE PRESSURE LOW**

Eliminate the possible problems in the order listed on chart and follow appropriate corrective measures.

Possible Problem	Actual Finding	Corrective Measure
1. Load conditions low (air/water temperatures).		Relocate ice machine to location within guidelines (refer to Installation Instructions).
2. Water regulating valve (water-cooled condenser): a. Out of adjustment. b. Leaking water during harvest cycle. c. Defective.		See proper adjustment, page 63. Readjust/replace if necessary.  Replace.
3. Fan motor/fan cycling switch defective.		Diagnose control, page 36.
4. Headmaster control valve defective (remote machines).		Refer to Headmaster Control Valve diagnostics, page 59.
5. Low refrigerant charge.		Continue through Six-Step Procedure.

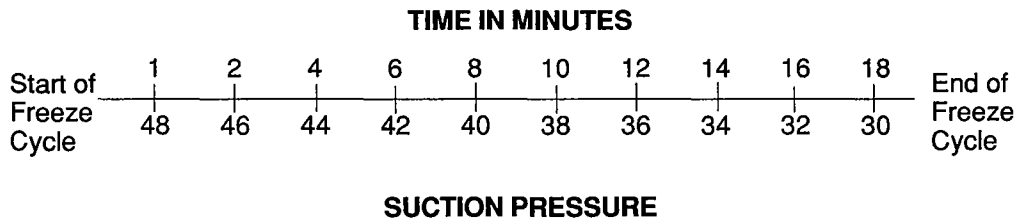
### Step 5B — Analyze Suction Pressure

**NOTE**

Discharge pressures must be analyzed before suction pressure.

To analyze suction pressure you must compare the Operational Pressure Chart, page 51, to the Cycle Time Chart, page 51. The suction pressure gradually drops as ice forms throughout the freeze cycle.

- A. **Normal suction pressure:** proceed through Six-Step Procedure. (Example: 38 psig after 10 minutes into the freeze cycle is normal at 90°F air and 70°F water.)
- B. **Low suction pressure:** Refer to Suction Pressure Low chart, page 54. (Example: 20 psig after 3 minutes into the freeze cycle is considered low.)
- C. **High suction pressure:** Refer to Suction Pressure High chart below. (Example: 46 psig after 10 minutes into the freeze cycle is considered high.)



By comparing the two charts you can determine if suction pressure is properly pulling down. Develop a chart as above and you will easily see where the suction pressure should be compared to the amount of time the ice machine is into the freeze cycle.

Example: G400 self-contained, water-cooled:  
 air temperature 90°F  
 water temperature 70°F

From Cycle Time Chart, page 51:  
 freeze time — 17 to 20 minutes  
 harvest time — 1 to 2 minutes  
 total cycle time — 18 to 22 minutes

From Operational Pressure Chart, page 51:  
 Suction pressure:  
 start of freeze — 48 psig  
 end of freeze — 30 psig

**NOTE**

If the ice machine is located in other than 90°F air and 70°F water another chart must be developed for comparison purposes.

### SUCTION PRESSURE HIGH

Eliminate the possible problems in the order listed on chart and follow appropriate corrective measures.

Possible Problem	Actual Findings	Corrective Measure
1. High discharge pressure affecting low side.		See Discharge Pressure High, page 52.
2. Hot gas valve stuck wide open.		Replace valve, page 62.
3. TXV flooding.		Continue through Six-Step Procedure.
4. Inefficient compressor (do not perform pumpdown test).		Continue through Six-Step Procedure.
5. Harvest pressure regulating solenoid valve leaking (remote machines).		Replace valve.

## SUCTION PRESSURE LOW

Eliminate the possible problems in the order listed on chart and follow appropriate corrective measures.

Possible Problem	Actual Findings	Corrective Measure
1. Low load conditions.		Relocate ice machine to location within guidelines.
2. Water system problem.		Refer to Step 4, page 50.
3. Tubing separating from back side of evaporator.		Replace evaporator.
4. Plugged drier/restriction in liquid line.		Repair — refer to Evacuation/Recharging Procedures, page 65.
5. TXV is starving/low on charge.		Continue through Six-Step Procedure.
6. Improper refrigerant charge.		Continue through Six-Step Procedure.

### Step 5C — Hot Gas Valve Check

#### POSSIBLE PROBLEMS:


1. Improper valve.  
A hot gas valve requires a specific orifice size which meters the proper amount of hot gas flow into the evaporator during the harvest cycle. Replace defective hot gas valves with "original" Manitowoc replacement (O.E.M.) parts only. Refer to your Parts Manual for proper valve application.

2. Stuck in harvest cycle: Check for voltage at coil.

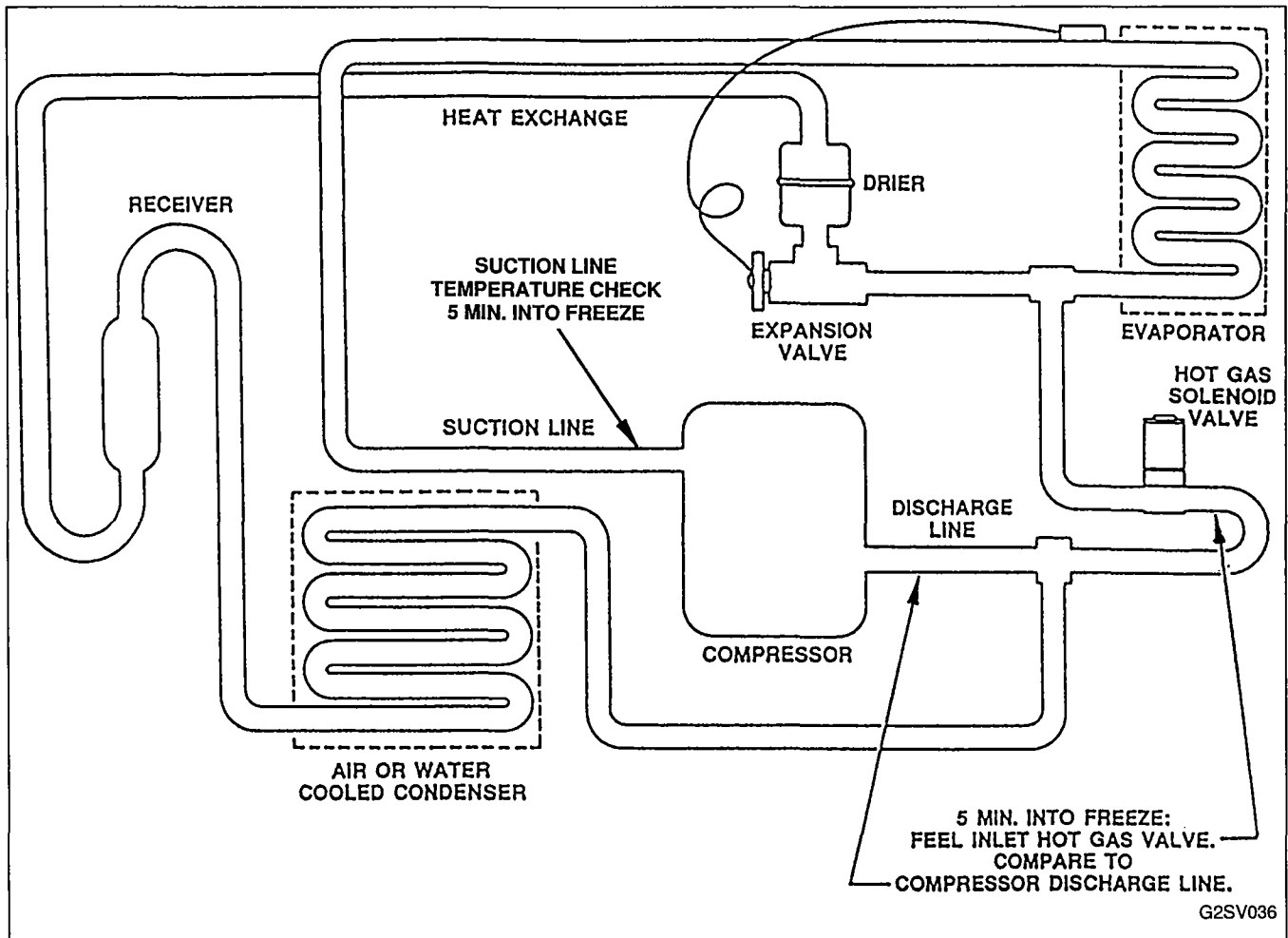
IF YES: Refer to Electrical Sequence of Operation, page 19 or 26.

IF NO: Normally a hot gas valve can be repaired without changing the entire valve. Rebuild or replace the hot gas valve as required. Refer to Refrigeration Solenoid Valve Replacement, page 62.

3. Leaking during freeze cycle.
  - a. Symptoms of leaking hot gas valve:
    - 1) Ice production loss will be normal.
    - 2) Ice fill on both evaporators will be normal.
    - 3) Suction pressure at the end of the freeze cycle will be slightly high. (This 1 to 4 psig increase can be difficult to detect.)
  - b. Check procedures (Figure 49, page 55).
    - 1) Feel **hot gas valve inlet** after 5 minutes into freeze cycle.

 **CAUTION**  
**HOT GAS VALVE INLET COULD BE HOT ENOUGH TO BURN YOUR HAND. JUST TOUCH IT MOMENTARILY.**

- 2) Determine if the inlet of hot gas valve is hot or close to compressor discharge line temperature.



**FIGURE 49. HOT GAS VALVE INLET FEEL CHECK/SUCTION LINE TEMPERATURE CHECK**

- 3) A **good hot gas** valve inlet line will be hot to touch during the harvest cycle and be cool enough to touch after approximately 5 minutes into the freeze cycle. With a **leaking hot gas valve**, the inlet will remain close to the discharge line temperature (hot to touch) during the freeze cycle.

Record your findings on the Refrigeration Component Diagnostic Chart, page 58.

Hot Gas Valve Inlet Feel Check Findings: (circle one)  
 Compressor discharge temperature — Hot or Cool  
 Hot gas solenoid **inlet** temperature — Hot or Cool

**Step 5D — Thermal Expansion Valve (TXV)/ Suction Line Temperature at Compressor**

**TXV POSSIBLE PROBLEMS:**

1. Improper valve.  
 An improper valve will not achieve a uniform ice fill on the evaporator or proper ice production under all load conditions. Manitowoc O.E.M. expansion valves use special bulb gas charges, port sizes and stroke lengths to achieve this. Refer to the Parts Manual for proper valve usage.
2. TXV not installed properly.  
 Refer to TXV Installation Procedures, page 61.

3. TXV starving or flooding.

A starving or flooding expansion valve may be reacting to or trying to compensate for other refrigeration problems. All conditions that could cause a good TXV to starve or flood must be eliminated. The following example emphasizes this point.

An ice machine low on charge will cause a good TXV to starve. A service technician forgets to verify system charge and replaces the TXV for starving.

While changing the TXV the evacuation/charging procedures are performed correctly, and the proper charge put into the ice machine. The ice machine functions properly and the technician thinks he has diagnosed the problem correctly (bad TXV). In reality the problem was corrected because the proper charge was put in the machine.

- a. Symptoms of a starving valve:
  - 1) Low ice production (may not make ice).
  - 2) Ice fill pattern — thin on top of evaporator and thick on bottom of evaporator.
  - 3) Suction pressure — lower than normal during freeze cycle.
- b. Symptoms of a flooding valve:
  - 1) Low ice production (may not make ice).
  - 2) Ice fill pattern — thick on top of evaporator and thin on bottom of evaporator.
  - 3) Suction pressure — higher than normal during freeze cycle.

**Suction Line Temperature Check (Figure 49, page 55).**

- 1. Measure the suction line temperature at the inlet of the compressor after 5 minutes into the freeze cycle.
- 2. Temperature indications:
  - a. No failure — a properly operating ice machine will maintain a temperature between 40°F and 70°F.
  - b. Hot gas valve leaking (not wide open) — temperatures will remain normal (between 40°F and 70°F).
  - c. Starving TXV — the temperatures will begin to climb above 50°F and, depending on how severe the failure, may go beyond the normal high of 70°F.
  - d. Flooding TXV — the temperatures will drop below the normal low of 40°F.

- e. Inefficient compressor (suction valves) — during the early stage of the failure temperature will be normal. As failure becomes worse the temperatures will rise above the normal high of 70°F.

Record your findings on the Refrigeration Component Diagnostic Chart, page 58, temperature of suction line at compressor.

**Step 5E — Compressor**

- 1. Suction valves (inefficient compressor).

An inefficient compressor can be hard to detect. Components or problems that are not directly related to the compressor can simulate a faulty compressor.

To diagnose a faulty compressor, systematically check other components and rule them out one by one. Following the entire Six-Step Procedure does this.

Symptoms of an inefficient compressor:

- a. Reduced ice production will be noticeable at lower ambient conditions and become more pronounced as ambient temperatures increase.
- b. Ice fill pattern — normal at lower ambients, although in extreme high ambient cases there may be little or no ice formation.
- c. Suction pressures at the end of freeze cycle will be slightly high and become more pronounced as ambient temperature increases.
- d. There may be intermittent flooding by the TXV.

**NOTE**

An inefficient compressor may “pump down” and hold; therefore this type of test must not be used as a determining factor for replacing compressors.

**IMPORTANT**

A broken compressor suction valve may allow enough gas to enter the suction side of the compressor causing the compressor and connecting lines to run extremely hot, including the inlet of the hot gas valve. This may give a false indication of a hot gas valve leaking.

## 2. Discharge valves.

### NOTE

Discharge valve related problems are extremely rare in this type of application.

- a. The compressor shell will become hot and compressor may cycle on overload.
- b. Suction pressure will be high.
- c. Discharge pressure will be lower than normal.
- d. Check procedure for discharge valves:
  - 1) Ensure compressor is running.
  - 2) Turn ice machine off.
  - 3) Immediately feel suction line — it will turn hot if the discharge valve is leaking or broken.

## STEP 6 — FINAL ANALYSIS

Thoroughly following the first 5 steps has eliminated all nonrefrigerant problems. The Refrigeration Component Chart will verify what is causing the problem.

Fill out the chart using the following procedures:

1. Based on the symptoms found while performing Steps 1 through 5, fill in the Actual Findings column.
2. Each time the actual finding is the same as the characteristic listed to the right of a step number, put a check in the appropriate box. (Example: the actual finding is “thin ice on top of evaporator.”) The box under starving TXV is the only box checked across the ice fill pattern section.
3. Add the number of boxes checked (under) each component failure and put the total in the bottom column. Refer to the component column with the most boxes checked and follow the appropriate procedures as listed in “a” through “d” below.

- a. Hot Gas Valve Leaking column: Normally a leaking hot gas valve can be repaired without changing the entire valve. Rebuild or replace the hot gas valve as required. Refer to Refrigeration Solenoid Valve Replacement, page 62.
- b. TXV Starving column: Verify the ice machine is not low on charge before replacing the TXV. Use the following guidelines:

### NOTE

A starving TXV will normally only affect the freeze cycle pressures. A low refrigerant charge will affect both freeze and harvest cycle pressures.

- 1) Add charge in 2 to 4 oz. increments to see if the problem is corrected.
  - 2) If problem is not corrected by adding charge, change the TXV and drier. (Refer to Evacuating/Recharging, page 65.)
  - 3) If problem is corrected by adding charge, find the refrigerant leak, change the drier, evacuate and recharge, page 65. (System must operate with proper charge — do not leave run without changing drier, evacuating, and recharging.)
- c. TXV Flooding column: Step 5A “Analyzing Discharge Pressure” has already verified the ice machine is not overcharged causing same symptoms as a flooding TXV. Replace the TXV and drier, evacuate, and recharge, page 65.
  - d. Inefficient Compressor column: Replace the compressor (and start components) and drier, evacuate, and recharge, page 65.

### NOTE

To receive warranty credit on compressor, old start components must be returned with faulty compressor.

## ICE MACHINE REFRIGERATION COMPONENT DIAGNOSTIC CHART

This chart is used with a detailed outline of each of the Six Steps listed.  
Failure to follow the details of each step in order will result in a misdiagnosis.

STEPS	HOT GAS VALVE LEAKING (not wide open)	TXV STARVING	TXV FLOODING	INEFFICIENT COMPRESSOR (suction valve)	ACTUAL FINDINGS
1. Visual Inspection	Visual inspection includes checking for proper installation, location, dirty condensers, etc., and talking to the ice machine user to identify the perceived problem(s).				
2. Ice Production	Normal ice production. <input type="checkbox"/>	1. Low ice production. 2. Not making ice. <input type="checkbox"/>	1. Low ice production. 2. Not making ice. <input type="checkbox"/>	1. Minimal ice production loss (almost normal). 2. Low ice production. <input type="checkbox"/>	
3. Ice Fill Pattern	Ice fill is normal. <input type="checkbox"/>	1. Ice fill will be thick on bottom portion of the evaporator and thin on top. 2. No ice. <input type="checkbox"/>	1. Ice fill will be thin on bottom portion of the evaporator and thick on top. 2. No ice. <input type="checkbox"/>	Ice fill is normal. <input type="checkbox"/>	
4. Water System	Water related problems can simulate a refrigeration component malfunction. Water related problems must be eliminated before proceeding to Step 5.				
Refrigeration System 5A. Discharge Pressure	Discharge pressure must be normal before proceeding to Step 5B.				
5B. Freeze Cycle Suction Pressure	Normal to 4 psig high at end of freeze cycle. <input type="checkbox"/>	Lower than normal throughout freeze cycle. <input type="checkbox"/>	Higher than normal throughout freeze cycle. <input type="checkbox"/>	Slightly higher throughout freeze cycle. Pressures normally do pull down although normally take a long time. <input type="checkbox"/>	
5C. Hot Gas Valve Inlet Feel Check	1. The inlet of hot gas valve is hot. 2. The compressor discharge is hot. <input type="checkbox"/>	1. The inlet of hot gas valve is cool. 2. The compressor discharge is hot. <input type="checkbox"/>	1. The inlet of hot gas valve is cool. 2. The compressor discharge is cool. <input type="checkbox"/>	1. The inlet of hot gas valve is cool. 2. The compressor discharge is hot. <input type="checkbox"/>	
5D. Suction Line Temperature at Compressor	40°F to 70°F. <input type="checkbox"/>	Above 50°F. <input type="checkbox"/>	Below 40°F. <input type="checkbox"/>	Above 40°F. <input type="checkbox"/>	
Miscellaneous	<input type="checkbox"/>	<input type="checkbox"/>	<input type="checkbox"/>	<input type="checkbox"/>	
6. Final Analysis (number of boxes checked)	A. <input type="checkbox"/>	B. <input type="checkbox"/>	C. <input type="checkbox"/>	D. <input type="checkbox"/>	

## HEADMASTER CONTROL VALVE (Remote Machines)

Manitowoc remote systems require Headmaster Control Valves with special settings. Replace defective Headmaster Control Valves **only** with "original" Manitowoc replacement parts.

### Operation

The R-502 Headmaster Control Valve has a non-adjustable setting of 185 psig ( $\pm 10$ ). At ambient temperatures of 70°F and above refrigerant flows through the valve from the condenser to the receiver inlet. At temperatures below 70°F the Headmaster pressure control dome's nitrogen charge closes the condenser port. The bypass port from the compressor discharge line opens. In this mode the valve maintains minimum compressor head pressure by building up liquid in the condenser and bypassing discharge gas directly to the receiver.

### Diagnosing Headmaster Control Valves

- Determine air temperature entering remote condenser.
- Determine if head pressure is low or high in relationship to outside temperature (refer to Operation Pressure Chart, page 51). If air temperature is below approximately 70°F, the head pressure should be modulating around 185 psig ( $\pm 10$ ).
- Determine the temperature of the liquid line entering the receiver by feeling with hand. This line is normally "body" temperature (warm).
- Refer to Failure Chart to determine cause.

#### NOTE

An ice machine with a failed Headmaster Control Valve that will not bypass will function properly with condenser air temperatures of approximately 70° or above. When the temperature drops below approximately 70° the Headmaster Control Valve fails to bypass and the ice machine malfunctions.

Use the following procedure if the ice machine is suspected of being low on charge:

- Add refrigerant in 2-pound increments but do not exceed 6 pounds.
- If the ice machine was low on charge the Headmaster Control Valve function and discharge pressure will return to normal after the charge is added. Do not leave ice machine operate; to assure operation in all ambient conditions the ice machine must be evacuated and recharged with proper nameplate charge.
- If the ice machine does not start to operate properly after adding charge, replace the Headmaster Control Valve.

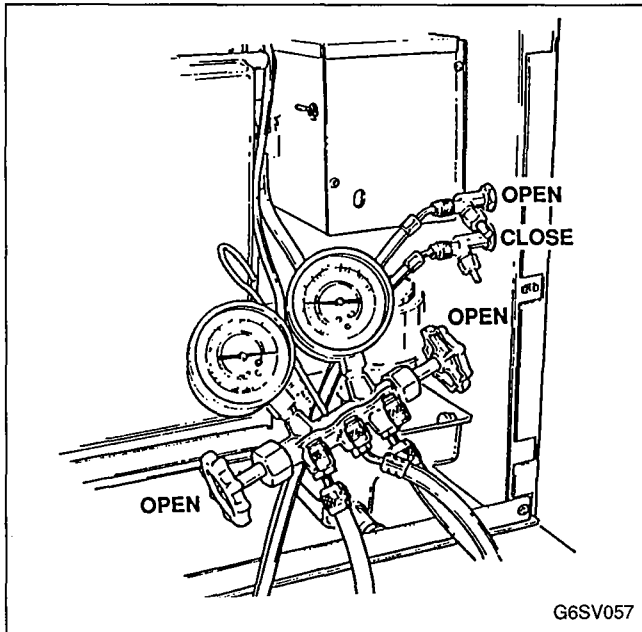
### HEADMASTER CONTROL VALVE FAILURE CHART

Possible Problem	Probable Cause	Corrective Measure
Valve not maintaining proper pressures.	Non-approved valve.	Install O.E.M. Headmaster Control Valve.
1. Discharge pressure extremely high. 2. Liquid line receiver feels hot.	Valve stuck in bypass.	Replace valve.
1. Discharge pressure low. 2. Liquid line entering receiver extremely cold.	Valve not bypassing.	Replace valve.
1. Discharge pressure low. 2. Liquid line entering receiver is warm to hot.	Suspect ice machine to be low on charge.	Refer to procedures above.

# HOW TO USE MANIFOLD GAUGES

Manifold gauges must be installed and removed properly to ensure no refrigerant contamination or loss occurs.

## INSTALLING MANIFOLD GAUGES



**FIGURE 50. INSTALLING MANIFOLD GAUGES**

1. Connect high side line to high side service valve at ice machine. See Figure 50.
2. Start low side line onto low side service valve at ice machine. Do not tighten.
3. Open both high and low side valves on manifold gauges. Be sure middle feed line is capped.
4. Open high side of machine at service valve. Refrigerant will bleed through manifold gauges up to the closed low side ice machine service valve.

### IMPORTANT

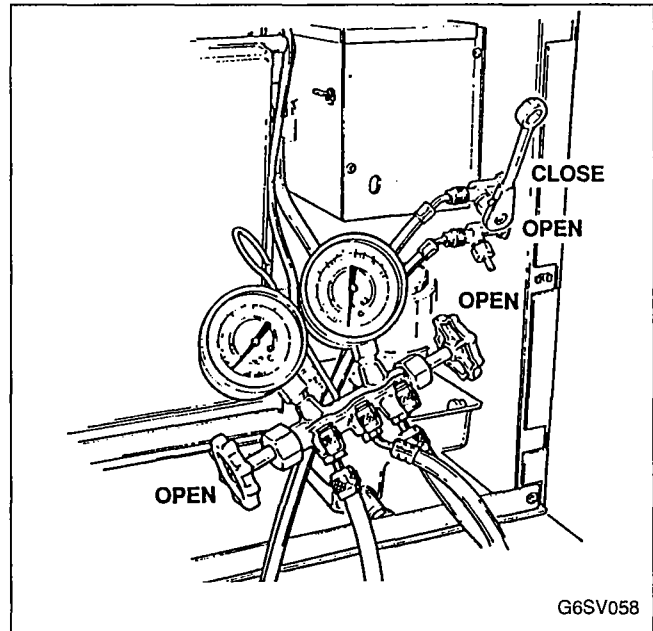
Tighten low side line as refrigerant bleeds through. This purges contaminants and noncondensables from manifold and hoses.

## READING OPERATIONAL PRESSURES

1. Close both high and low side valves on manifold gauge set.

2. Open both high and low side service valves at the ice machine.
3. With machine operating, read high and low side pressures on gauges.

## REMOVAL OF MANIFOLD GAUGES



**FIGURE 51. REMOVAL OF MANIFOLD GAUGES**

1. Run ice machine in freeze cycle.
2. Close high side service valve at ice machine.
3. Open low side service valve at ice machine.
4. Open both high and low side valves on manifold gauge set. Refrigerant in lines will now be pulled into the low side of system. Allow pressures to equalize with ice machine still in freeze cycle.
5. Close low side service valve at ice machine.
6. Remove hoses from ice machine and install caps.

### NOTE

Removing manifold properly will ensure you do not alter charge and will eliminate releasing C.F.C.'s into atmosphere.

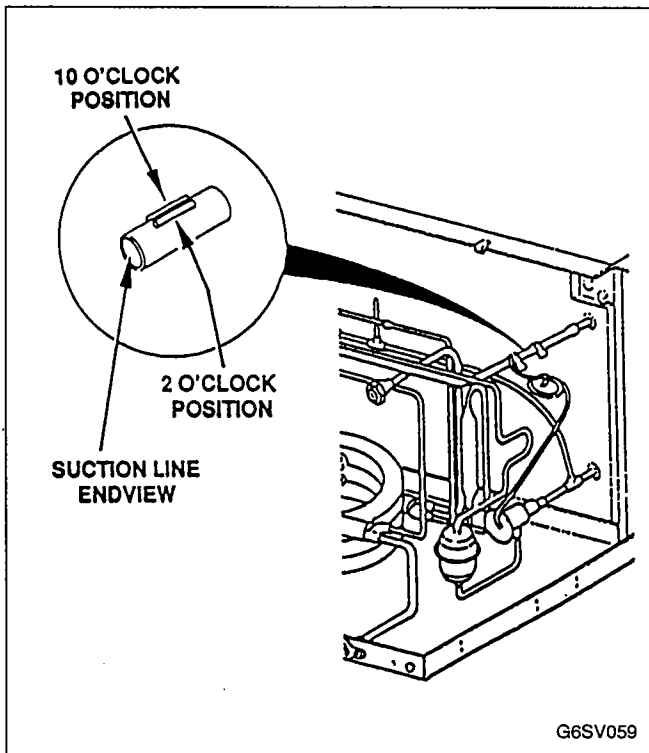
# TXV INSTALLATION

Correct expansion valve installation is essential for proper operation. Some key points to remember when installing a valve include:

## SOLDERING IN VALVE

Wrap the TXV with a wet rag. This will prevent damage to the valve from overheating.

## BULB LOCATION



**FIGURE 52. TXV BULB LOCATION**

Bulb must be clamped to a smooth, straight, clean copper tube, not to a weld joint. Mount the bulb at the 10:00 or 2:00 o'clock position (Figure 52).

## BULB CLAMP LOCATION

All Manitowoc expansion valve bulbs are to be mounted with two stainless steel screw clamps (Figure 52). Both clamps must be used. Clamps must be flush with each end of the bulb. Do not put both clamps in the middle of the bulb, as this can cause the bulb to bow or warp.

## BULB CLAMP TIGHTNESS

Bulbs must be tight for good thermal contact. A properly tightened bulb will not move around the suction line when twisted by hand. Properly tightened clamps may slightly deform the bulb. This is normal and will not hurt valve operation.

## BULB INSTALLATION CHECK

To check if the bulb has good thermal contact, hold a flashlight under the bulb and look for light between the bulb and the suction line. If no light is seen, the contact is good. If light can be seen between the bulb and the suction line, the contact is poor, and the valve may misfeed. The bulb must be retightened and/or moved slightly and rechecked.

## BULB INSULATION

The bulb insulation must be at least 3/8 inch thick. If thinner insulation is used, apply additional layers.

### NOTE

Insulate the valve body to prevent sweating.

# ALCO REFRIGERATION SOLENOID VALVE (200 RB SERIES) REPLACEMENTS

The internal parts of Alco solenoid valves (200 RB Series) are replaceable without changeout of the brass body. Rebuild kit, Manitowoc part No. 24-0460-3, is available for these Alco solenoid valves. The rebuild kit includes the plunger, spring, O-ring, and piston assembly. A solenoid valve which has a damaged seat or is stuck open or closed can, in most cases, be repaired by installing the rebuild kit. See Figure 53.

Use the following guidelines for warranty replacements.

1. Install rebuild kit when the enclosing tube and brass valve body are **not defective**.
2. Replace the entire solenoid assembly when the brass valve body is found defective or if the internal surface of the enclosing tube does not permit smooth plunger and piston operation.
3. Replace coil only when a coil malfunctions (open, shorts, etc.).

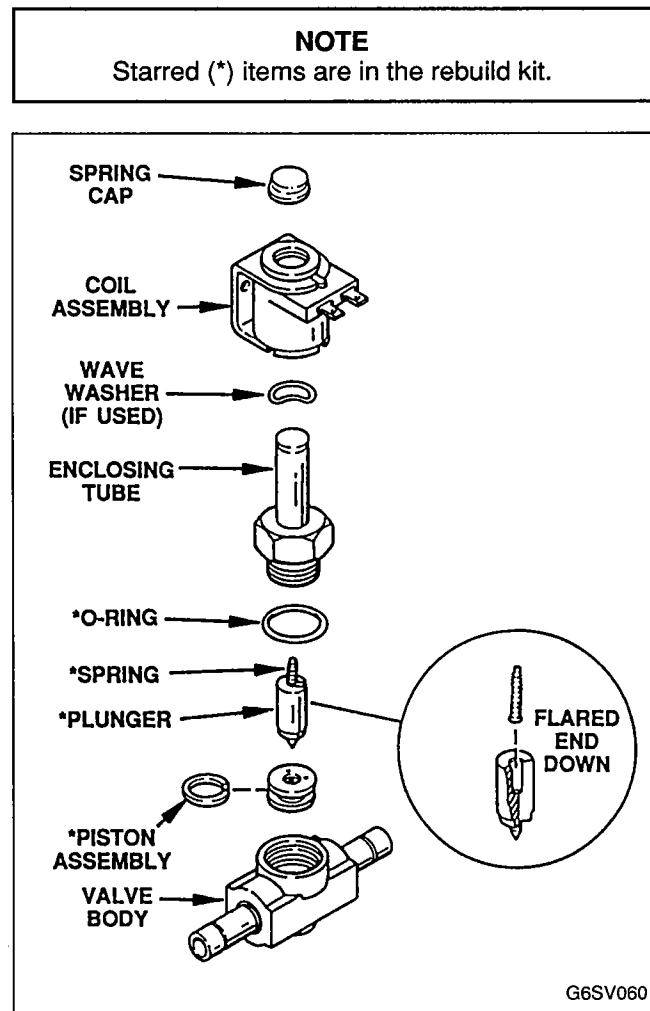
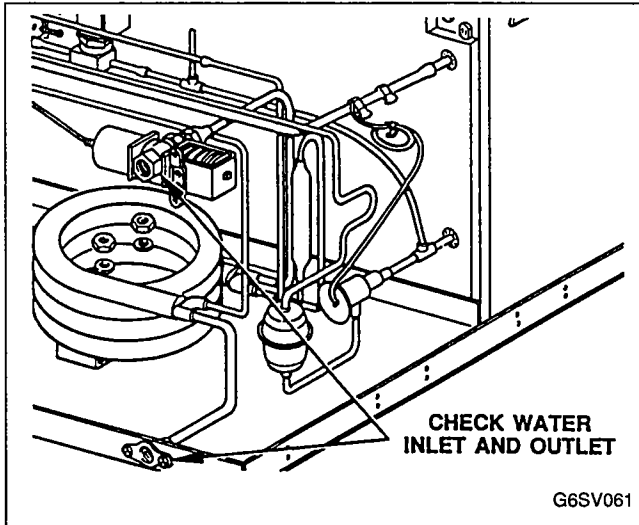


FIGURE 53. REFRIGERATION SOLENOID VALVE

# LEAK CHECKING CONDENSER AND WATER REGULATING VALVE

## IMPORTANT

Both the condenser and water regulating valve must be leak checked.



**FIGURE 54. CONDENSER LEAK CHECK POINTS**  
**LEAK CHECKING CONDENSER**

1. Set ICE/OFF/WATER PUMP switch at OFF.
2. Turn off incoming condenser water supply.
3. Disconnect incoming condenser water inlet and outlet lines.
4. Disconnect water regulating valve from condenser.
5. Blow water out of condenser with compressed air.

## NOTE

Water in the condenser may cause an electronic leak detector to give a false signal.

6. Ensure refrigeration system is pressurized.
7. Check condenser water inlet and outlet with electronic leak detector. If a leak is detected, replace condenser. See Figure 54.

## NOTE

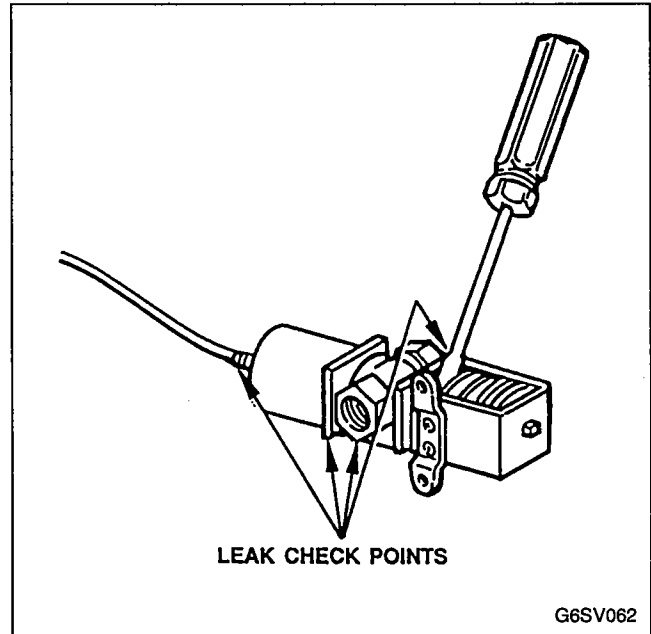
If no leak is detected with the ice machine off, set the ICE/OFF/WATER PUMP switch at ICE. Allow discharge pressure to reach 250 psig, then set ICE/OFF/WATER PUMP switch at OFF and recheck for leaks.

## LEAK CHECKING WATER REGULATING VALVE

## NOTE

Water regulating valve must be disconnected from the condenser. Completely dry water valve inlet and outlet to eliminate false readings from the leak detector.

1. Ensure refrigeration system is pressurized.
2. Leak check where cap tube meets the bellows housing. See Figure 55.
3. Leak check around bellows seal.
4. Open valve by prying open at spring with screwdriver, leak check inlet and outlet with leak detector. If leak is detected, replace valve.
5. If no leak is detected, refer to NOTE under step 7 of Leak Checking the Condenser and recheck valve for leaks.



**FIGURE 55. WATER REGULATING VALVE**  
**LEAK CHECK POINTS**

# REMOVAL FROM SERVICE/WINTERIZATION

You must take special precautions if the ice machine is to be removed from service for extended periods or exposed to ambient temperatures of 32°F or below.



## CAUTION

**IF WATER IS ALLOWED TO REMAIN IN THE MACHINE IN FREEZING AMBIENT TEMPERATURES, IT WILL FREEZE, RESULTING IN SEVERE DAMAGE TO COMPONENTS. A FAILURE OF THIS NATURE IS NOT COVERED BY WARRANTY.**

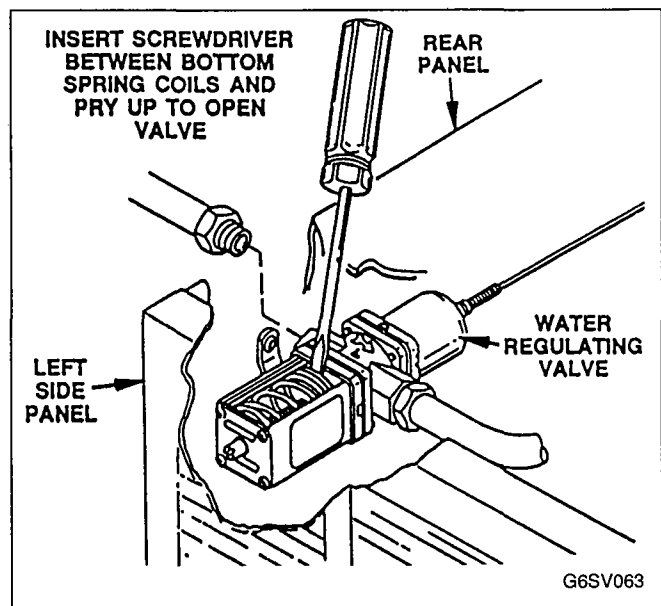
### Air-Cooled Machines

1. Disconnect electric power at circuit breaker or electric service switch.
2. Turn off water going to ice machine.
3. Remove drain plug from water trough.
4. Disconnect drain line and incoming ice making water line at rear of ice machine.
5. Blow compressed air in both incoming water opening and drain opening in rear of machine until water is no longer coming out of float valve and drain.
6. Ensure that no water is trapped in any of the machine's water lines, drain lines, distribution tubes, etc.
7. If ice machine is outside, cover machine to prevent exposure to elements.

### Water-Cooled Machines

1. Perform all procedures listed under Air-Cooled Machines.
2. Disconnect incoming water line and drain line from water-cooled condenser.

3. Pry open water regulating valve by inserting large standard screwdriver between bottom spring coils of valve. Pry spring upward to open valve, Figure 56.
4. Hold valve open and blow compressed air through condenser until no water remains.
5. Ensure no water is trapped in the water lines, drain lines and distribution tube.
6. If ice machine is outside, cover machine to prevent exposure to elements.



**FIGURE 56. MANUALLY OPENING WATER REGULATING VALVE**

# EVACUATION AND RECHARGING

## REMOVAL OF REFRIGERANT

Do not purge the refrigerant to the atmosphere. Capture refrigerant using recovery equipment by following specific manufacturer's recommendations.

### IMPORTANT

Manitowoc Ice, Inc. assumes no responsibility for the use of recycled refrigerant. Damage resulting from the use of recycled refrigerant is solely the responsibility of the servicing company.

## GAUGE SET/VACUUM PUMP INSTALLATION PROCEDURE (Self-Contained)

### IMPORTANT

Refer to refrigeration system Contamination Clean-Up Procedures, page 70, for proper clean-up procedures if system contamination is suspected or detected. Improper or insufficient clean-up will lead to repeat failures.

1. Replace liquid line drier.

### IMPORTANT

TO PREVENT VOIDING WARRANTY, USE ONLY MANITOWOC (O.E.M.) LIQUID LINE FILTER DRIERS.

2. Fully open service valves, Figure 57.

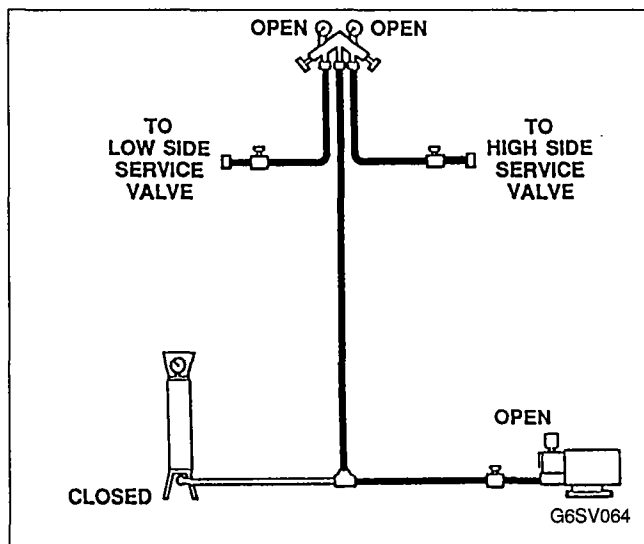


FIGURE 57. EVACUATION OF SELF-CONTAINED SYSTEMS

### NOTE

Install a two-stage vacuum pump to manifold gauges. A single stage pump will slow the evacuation process.

## Procedures for Self-Contained Evacuation (Figure 57)

1. Ensure the toggle switch is in the OFF position.
2. Open (backseat) high and low side ice machine service valves. Open vacuum pump valve. Open high and low side on manifold gauges.
3. Start vacuum pump. Pull system down to 250 microns. Allow pump to run for 1/2 hour after reaching 250 microns.
4. Refer to Recharging Procedures and recharge ice machine.

## Procedures for Self-Contained Recharging (Figure 58)

### IMPORTANT

Charge must be weighed or measured into ice machine to assure proper operation under all load conditions. Do not charge by sight glass, pressure, etc.

1. Ensure toggle switch is in OFF position.

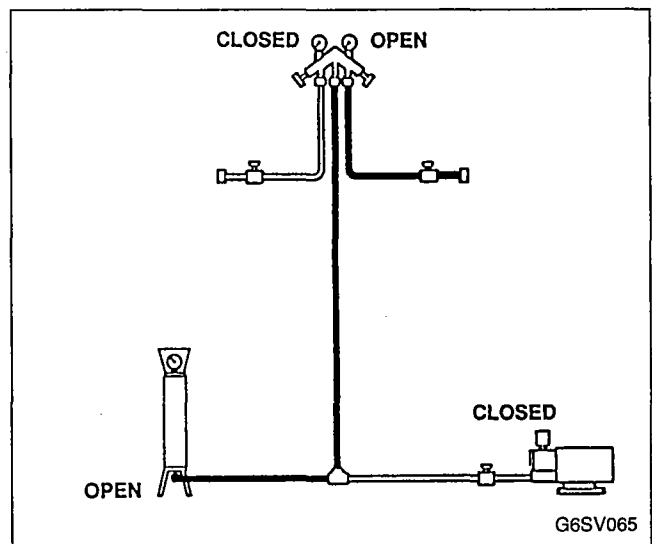


FIGURE 58. RECHARGING OF SELF-CONTAINED SYSTEMS

2. Close vacuum pump valve, low side service valve, and low side valve on manifold gauge.

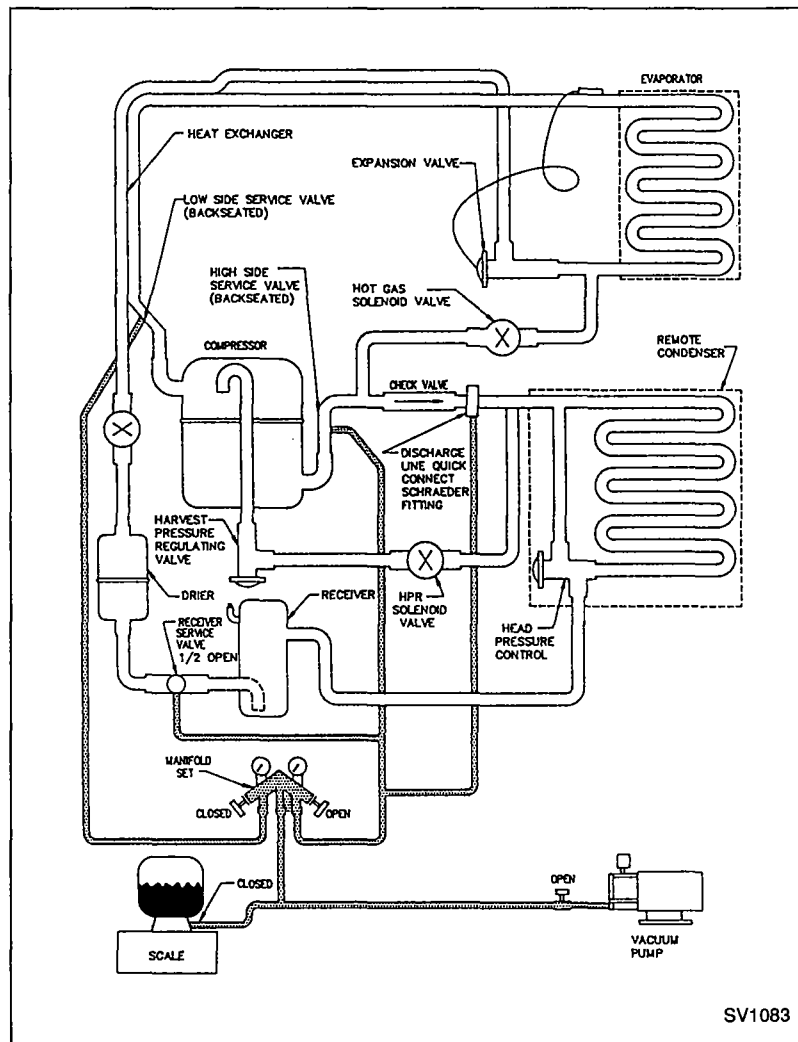
3. Open high side manifold gauge valve, backseat high side service valve.
4. Open charging cylinder and add measured nameplate charge through discharge service valve.
5. Allow system to "settle" for 2 or 3 minutes after charging.
6. Place ice machine toggle switch in ICE position, close high side on manifold gauge set, and add

remaining vapor charge through suction service valve (if necessary).

7. Ensure all vapor in charging hoses is drawn into the ice machine before disconnecting manifold gauges. Refer to How to Use Manifold Gauges, page 60.

**NOTE**

Recheck for leaks with a Halide or electronic leak detector after recharging ice machine.



**FIGURE 59. EVACUATION OF REMOTE SYSTEMS**

## **GAUGE SET/VACUUM PUMP INSTALLATION PROCEDURE (Remote) (Figure 60)**

### **IMPORTANT**

Refer to refrigeration system Contamination Clean-Up Procedures, page 70, for proper clean-up procedures if system contamination is suspected or detected. Improper or insufficient clean-up will lead to repeat failures.

1. Evacuation of remote systems requires connection at four points for complete evacuation as follows. Refer to Figure 59.
  - a. Suction side of compressor through suction service valve.
  - b. Discharge side of compressor through discharge service valve.
  - c. Receiver outlet service valve. (Evacuates area between head pressure control valve in condenser and pump-down solenoid.)
  - d. Access (Schraeder) valve on discharge line quick connect fitting on outside of compressor/evaporator compartment. This connection is necessary to evacuate the condenser. Without this connection, the magnetic check valve would close upon the pressure drop produced by evacuation prohibiting complete condenser evacuation.

### **NOTE**

Manitowoc recommends using an access valve core removal and installation tool on the discharge line quick connect fitting. The tool permits removal of the access valve core for faster evacuation and charging without removing the manifold gauge hose.

### **NOTE**

Install a two-stage vacuum pump to manifold gauges. A single-stage pump will slow the evacuation process.

### **Procedures for Remote System Evacuation**

1. Ensure toggle switch is in the OFF position.
2. Install manifold gauges, scale and two-stage vacuum pump as shown on Figure 59.

3. Open (backseat) high and low side ice machine service valves, position receiver service valve 1/2 open, and open high and low side on manifold gauge set.

### **NOTE**

If access valve core removal and installation tool is used, remove discharge line quick-connect valve core at this time.

4. Start vacuum pump, pull system down to 250 microns. Allow pump to run for 1 hour after reaching 250 microns. Turn off vacuum pump, ensure pressures do not rise (standing vacuum leak-check).
5. Charge the ice machine per the following charging procedures.

### **Procedures for Remote System Recharging**

1. Ensure toggle switch is in the OFF POSITION.
2. Close vacuum pump valve, frontseat (close) low side and high side service valves, close low side valve on manifold gauge set.
3. Add measured nameplate charge from charging scale through high side of manifold gauge set into system high side (receiver outlet valve and discharge lines quick-connect fitting).
4. If high side does not take entire charge, close high side on manifold gauge set, backseat (open) low side service valve, and receiver outlet service valve. Start ice machine and add remaining charge through low side in vapor form until the machine is fully charged.
5. Ensure all vapor in charging hoses is drawn into the machine before disconnecting manifold gauges.

### **NOTE**

Backseat (open) receiver outlet service valve after charging is complete and before operating the ice machine. If access valve core removal and installation tool is used on the discharge line quick-connect fitting, reinstall Schraeder valve core before disconnecting access tool and hose.

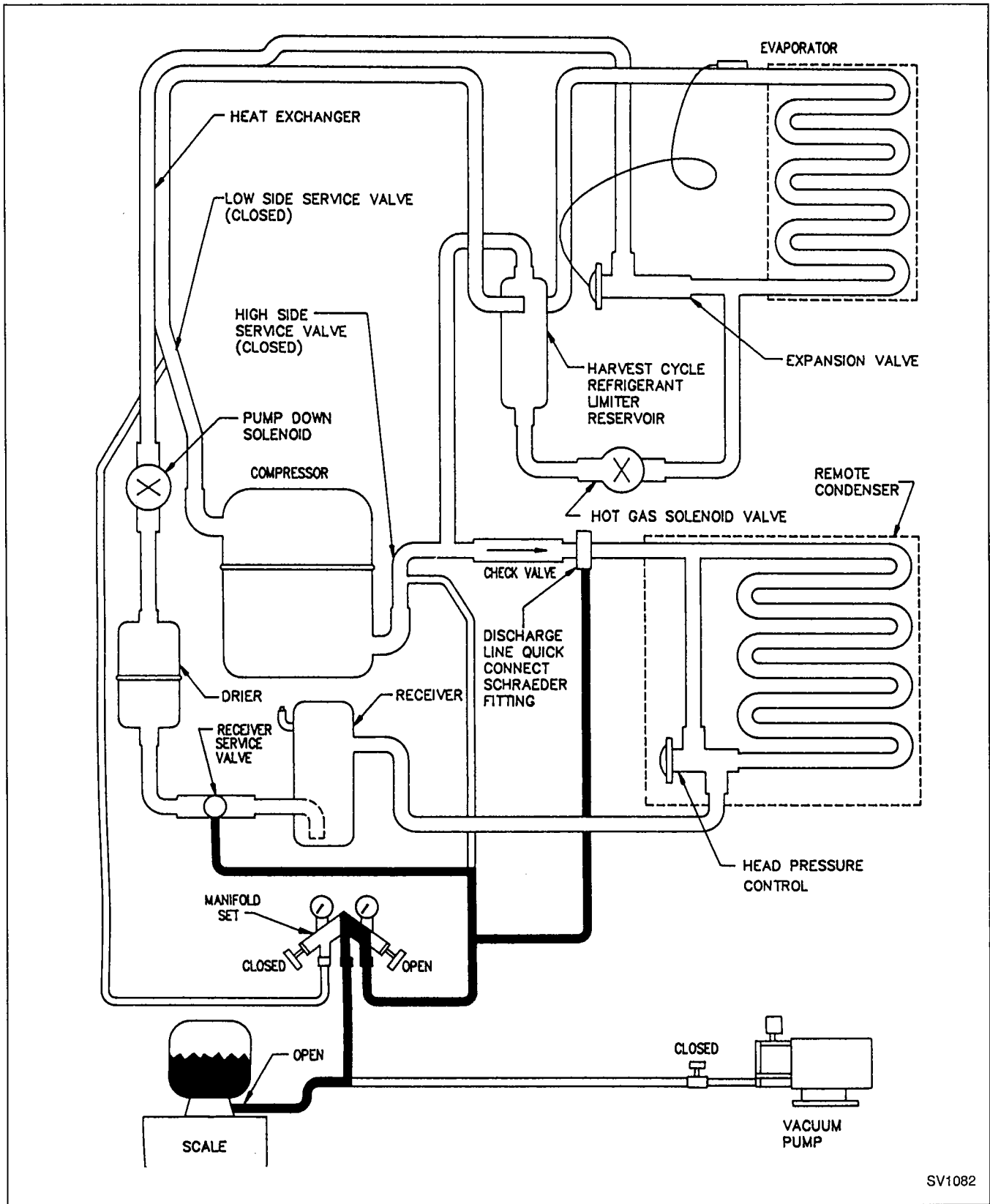


FIGURE 60. RECHARGING OF REMOTE SYSTEMS

# SEVERE SYSTEM CONTAMINATION

## GENERAL

It is important to read and understand the following text regarding severe system contamination. The purpose is to describe the basic requirements for restoring contaminated systems to reliable service.

### IMPORTANT

Manitowoc Ice, Inc. assumes no responsibility for use of recycled refrigerant. Damage resulting from the use of contaminated recycled refrigerant is the sole responsibility of the servicing company.

## DETERMINING SEVERITY OF CONTAMINATION AND CLEAN-UP PROCEDURES

System contamination is generally caused by the introduction of either moisture or residue from compressor burnout into the refrigeration system.

Inspection of the refrigerant is usually the first indication of contaminants in the system. If obvious moisture or an acrid odor indicating burnout is present in the refrigerant, steps must be taken to determine the severity of contamination as well as the required clean-up procedure.

If visible moisture or an acrid odor is detected, or if contamination *is suspected*, the use of a Total Test Kit from Totaline or similar diagnostic tool is recommended. These devices read refrigerant, therefore eliminating the need for an initial oil sample for testing.

If a refrigerant test kit indicates harmful levels of contamination, or if the kit is not available, then inspect the compressor oil as follows:

1. Remove refrigerant charge from ice machine.
2. Remove compressor from the system.
3. Check odor and condition (appearance) of the oil.
4. Inspect open suction and discharge lines at compressor for burnout deposits.
5. Perform an acid oil test if contamination signs are not evident per the above procedure to ensure no harmful contamination is present.

The following chart lists findings and matches them with required clean-up procedure. Use this chart for determining type of clean-up required.

**CONTAMINATION/CLEAN-UP CHART**

Symptoms/Findings	Required Clean-Up Procedure
No symptoms or suspicion of contamination	Normal evacuation and recharging procedures, page 65.
Moisture/Air Contamination (one or more of the following conditions will exist) — Refrigeration system open to atmosphere for prolonged periods — Refrigeration test kit and/or acid oil test shows contamination — Leak in water-cooled condenser — Oil appears muddy, or visible moisture in oil	Mild contamination clean-up procedures, page 70.
Mild Compressor Burnout — Oil appears clean with acrid odor and/or — Refrigeration test kit or acid oil test shows harmful acid content — No burnout deposits in open compressor lines	Mild contamination clean-up procedures, page 70.
Severe Compressor Burnout — Oil discolored and acidic with acrid odor, burnout deposits in compressor, discharge and suction lines and other components	Severe contamination clean-up procedures, page 70.

## **MILD SYSTEM CONTAMINATION CLEAN-UP PROCEDURES**

1. Replace failed components if applicable. If compressor checks good, change oil in compressor.
2. Replace liquid line drier.
3. Follow normal evacuation procedure, page 65, except replace the evacuation step with the following:

### **NOTE**

If contamination is from moisture, the use of heat lamps or heaters is recommended during evacuation. Place heat lamps at the compressor, condenser, and at the evaporator prior to evacuation. (Ensure heat lamps are not positioned too close to plastic components such as evaporator extrusions, water trough, etc., as they could melt, warp, etc.)

### **IMPORTANT**

Dry nitrogen is recommended for this procedure to prevent C.F.C. release into the atmosphere.

- a. Pull vacuum to 1000 microns. Break vacuum with dry nitrogen and sweep system. Pressurize to a minimum of 5 psig.
  - b. Pull vacuum to 500 microns. Break vacuum with dry nitrogen and sweep system. Pressurize to a minimum of 5 psig.
  - c. Change vacuum pump oil. Pull system down to 250 microns. When 250 microns have been achieved, allow vacuum pump to run for 1/2 hour for self-contained models, 1 hour for remotes. A standing vacuum test may be performed at this time as a preliminary means of leak checking; however, the use of an electronic leak detector after the system has been charged is recommended.
4. Charge system with proper refrigerant to nameplate charge.
  5. Operate ice machine.

## **SEVERE SYSTEM CONTAMINATION CLEAN-UP PROCEDURES**

1. Remove refrigerant charge.
2. Remove compressor.
3. Disassemble hot gas solenoid valve. If burnout deposits are found inside valve, install rebuild kit and replace TXV. If contaminants are found replace harvest pressure limiter control.
4. Check discharge and suction lines at compressor for burnout deposits. Wipe out as necessary.

5. Sweep through open system with dry nitrogen.

### **NOTE**

Refrigerant sweeps are not recommended, as they release C.F.C.'s into the atmosphere.

6. Installation Procedures:
  - a. Install new compressor and start components.
  - b. Install an adequately sized suction line filter-drier with acid/moisture removal capability and inlet/outlet access valves. Place the filter-drier as close to the compressor as practical.
  - c. Replace liquid line filter-drier.
7. Follow normal evacuation procedures, page 65, except replace the evacuation step with the following:

### **IMPORTANT**

Dry nitrogen is recommended for this procedure to prevent C.F.C. release into the atmosphere.

- a. Pull vacuum to 1000 microns. Break vacuum with dry nitrogen and sweep system. Pressurize to a minimum of 5 psig.
  - b. Change vacuum pump oil. Pull vacuum to 500 microns. Break vacuum with dry nitrogen and sweep system. Pressurize to a minimum of 5 psig.
  - c. Change vacuum pump oil. Pull system down to 250 microns. When 250 microns have been achieved, allow vacuum pump to run for 1/2 hour for self-contained models, 1 hour for remotes. A standing vacuum test may be performed at this time as a preliminary means of leak checking; however, the use of an electronic leak detector after the system has been charged is recommended.
8. Charge system with proper refrigerant to nameplate charge.
  9. Operate ice machine.
    - a. Check pressure drop across the suction line filter-drier after 1 hour running time. If pressure drop is not excessive (up to 1 psig differential) the filter-drier should be adequate for complete clean-up. Proceed to step 10.
    - b. If pressure drop is greater than 1 psig after 1 hour run time, change the suction line filter-drier and liquid line drier. Repeat until ice machine will run 1 hour without pressure drop.
  10. Remove suction line filter-drier after 48-72 hours run time. Change liquid line drier and follow normal evacuation procedures, page 65.



**MANITOWOC ICE, INC.**

2110 South 26th Street P.O. Box 1720

Manitowoc, WI 54221-1720

Phone: (920) 682-0161

Fax: (920) 683-7585

**Web Site:** [www.manitowocice.com](http://www.manitowocice.com)

© 1999 Manitowoc Ice, Inc.  
Litho in U.S.A.