

Manitowoc®

ICE MACHINES

INSTALLATION INSTRUCTIONS

MODELS:

GR-0400A
GD-0402A
GY-0404A
GR-0401W
GD-0403W
GY-0405W
GR-0490N
GD-0492N
GY-0494N

This product qualifies for the following listings:



KEEP THESE INSTRUCTIONS WITH THE OWNER/OPERATOR USE AND CARE GUIDE FOR FUTURE REFERENCE

GENERAL SAFETY PRECAUTIONS

The ice machine must be installed according to these Installation Instructions.

Connection to water service, drains, electrical service and grounding must comply with applicable local and state codes.

Disconnect electrical service before servicing.

Read and understand all instructions before placing the ice machine into service.

GENERAL

The installation instructions are provided to assist the qualified installer. Check the yellow pages of your local telephone book for Manitowoc Ice Machine Distributor, or call Manitowoc Ice, Inc. for information regarding installation and start-up services available.

If any problem is encountered that is not covered by this manual, please contact your local Manitowoc Distributor or Manitowoc Ice, Inc. for assistance.

TABLE OF CONTENTS

General Safety Precautions	1
General	1
Dimensions	2
Specifications	3
Freight Damage and Claims Procedures	3
Unpacking Cartons	4
Location of Ice Machine	4
Ice Machine Heat of Rejection	4
Mounting Single Ice Machine on Storage Bin	4
Mounting Two Ice Machines on Storage Bin	5
Electrical Service	5
Voltage	5
Fuse/Circuit Breaker	5
Minimum Circuit Ampacity	5
Connection at Self-Contained Ice Machine	6
Water Service/Drains	7
Water Supply	7
Inlet Water Connections	8
Drain Connections	8
Water-Cooled Models (Cooling Tower Applications)	8
Remote Ice Machine Installation	8
General Information	8
Ice Machine Set-up	9
Remote Air Condenser Assembly	9
Location of Remote Condenser	10
Routing of Line Sets	10
Connection of Line Set	11
Remote Ice Machine Electrical Hook-Up	13
Dual Circuit Condensers, DC Models	14
Single Circuit Condensers, AC Models	14
Receiver Service Valve	14
Installation Check List	15
Additional Ice Machine Checks for Remote Models	15
Before Starting Ice Machine	15

DIMENSIONS

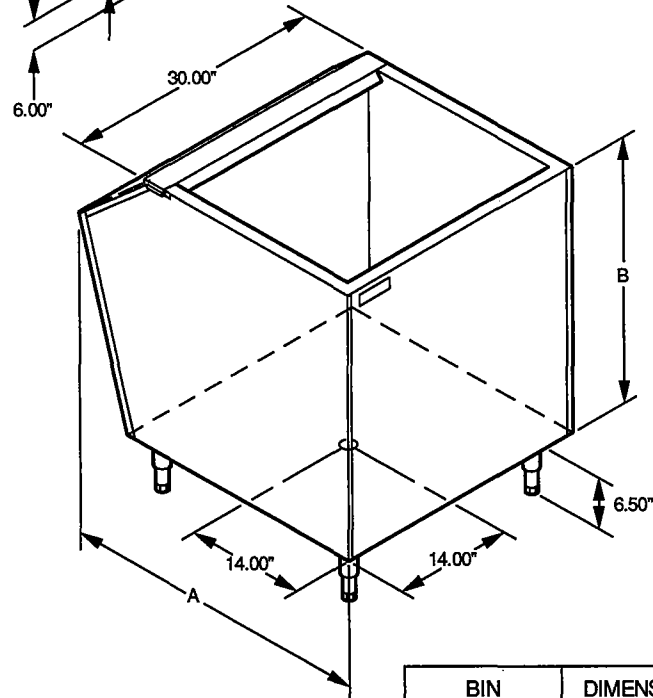
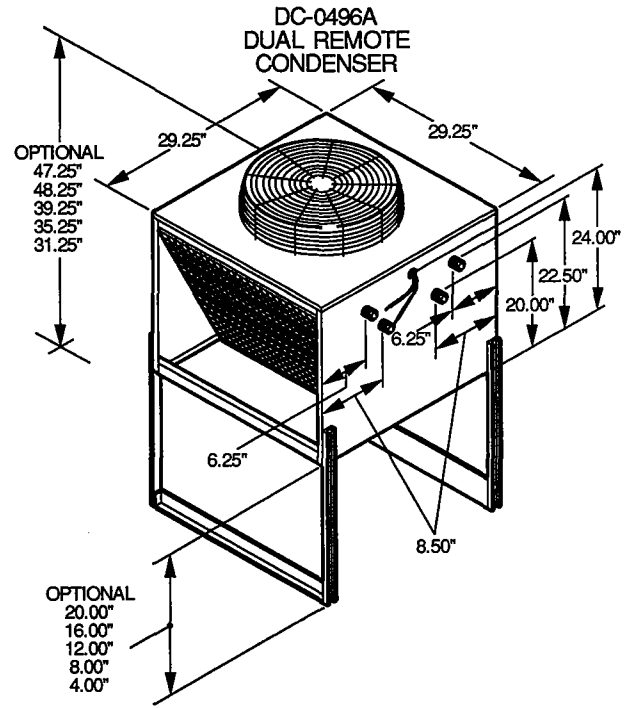
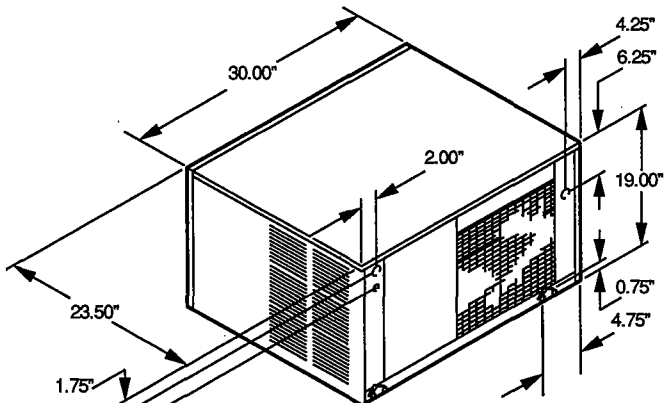
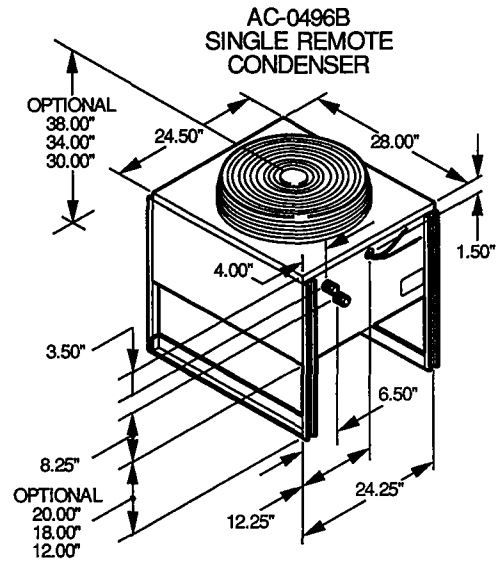
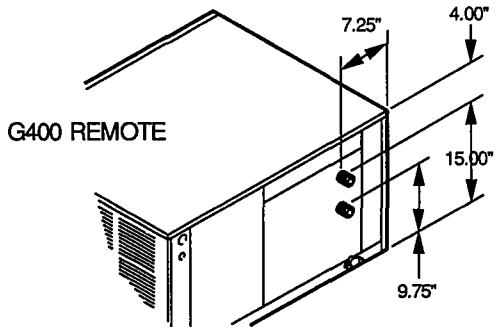

BIN MODEL	DIMENSION A	DIMENSION B
C400	34.00"	31.25"
C470	29.50"	50.50"
C570	34.00"	50.50"

mi/3282.009/00

SPECIFICATIONS

DIMENSIONS		ELECTRICAL REQUIREMENTS (Cont.)	
Length	23.50 in.	Fuse/Circuit Breaker	
Width	30.00 in.	Air-Cooled	25 amp
Height	19.00 in.	Water-Cooled	20 amp
ELECTRICAL REQUIREMENTS		Remote	20 amp
Voltage	115 volts	WATER REQUIREMENTS	
Hertz	60 Hertz	Temperature	
Phases	1 phase	Minimum	33°F
Circuit Ampacity (Minimum)		Maximum	90°F
Air-Cooled	14.9 amp	Pressure	
Water-Cooled	11.6 amp	Minimum	20 psi
Remote	14.0 amp	Maximum	80 psi

FREIGHT DAMAGE AND CLAIMS PROCEDURES

1. SHORTAGES

Check number of cartons delivered against the quantity shown on your receipt. If quantities do not tally, have driver note shortage and file your claim with the freight company.

2. NO-FAULT FREIGHT CLAIM PROCEDURE

Manitowoc assumes responsibility for all freight damage claims involving participating carriers with the following exceptions:

- When the trucking company loses the equipment.
- When fire destroys the equipment en route.
- When a traffic accident damages the shipment en route.

3. VISIBLE DAMAGE

- If cartons appear damaged in any way, open the carton and inspect contents in the presence of the driver.

- To remove the ice machine carton, cut the banding on the bottom only (in case the ice machine needs to be reboxed) and slide the carton up and off the ice machine.
- Note the nature and extent of the damage on the freight bill.
- Notify your local Manitowoc distributor to inspect the merchandise within 15 days of delivery. Do not attempt to repair the damage.

4. CONCEALED DAMAGE

- If damage is noticed at the time of installation, notify the distributor immediately and ask to have the equipment inspected.
- Do not destroy packing materials until inspection is completed.
- These conditions must be met before your claim can be processed by the distributor.

5. CLAIMS

Manitowoc Ice, Inc. and the selling Distributor will arrange to repair or replace the equipment.

UNPACKING CARTONS

1. ICE MACHINE
 - a. Cut bottom band on the carton.
 - b. Lift the carton up and off of the ice machine.
2. STORAGE BIN
 - a. Cut the banding on the top of the carton.
 - b. Remove carton top.
 - c. Remove the cardboard packing inside and place on the floor.
 - d. Tip the carton on its back and slide the bin out onto the cardboard packing to protect the bin from being scratched.
 - e. Screw the leveling legs onto the bottom of the bin and screw the "foot" of each leg in as far as possible, Figure 1. Set the bin upright.

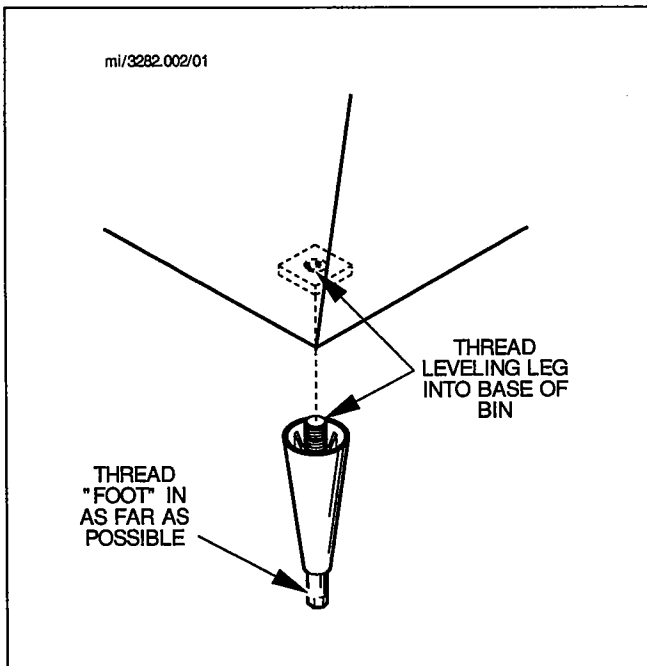

FIGURE 1. LEG INSTALLATION

LOCATION OF ICE MACHINE

CAUTION

We do not recommend that this ice machine be installed in an area where the air temperature falls below 35°F or exceeds 110°F. If the ice machine will be subjected to below freezing temperatures, it must be protected. See REMOVAL FROM SERVICE/WINTERIZATION in the Owner/Operator Use and Care Guide.

Select a location away from heat generating equipment and direct sunlight. Manitowoc ice machines operate most efficiently when:

- **LOCATED IN A CONTAMINANT-FREE AREA** — Air-cooled models especially should be installed in an area that is free of air-borne contaminants. An accumulation of contaminants on the condenser will adversely affect ice production.
- **INSTALLED WITH A MINIMUM OF FIVE INCHES OF CLEARANCE AT SIDES AND REAR** — Adequate air flow through and around the ice machine is essential to maximum ice production and long component parts life.

ICE MACHINE HEAT OF REJECTION

Ice machines, like other refrigeration equipment, reject heat through the condenser. It is helpful to know the amount of heat rejected to accurately size air conditioning equipment when self-contained air-cooled ice machines are installed in air conditioned environments. **This heat rejection information is also necessary to evaluate the benefits of using water-cooled or remote condensers to reduce air conditioning loads.** The amount of heat added to an air conditioned environment by an ice machine using a water-cooled or remote condenser is negligible. Knowing the amount of heat rejected is also important when sizing a cooling tower for a water-cooled condenser unit.

Series G400 Heat Rejection (BTU/Hour)

Air Conditioning	Peak
*7,000	**9,600

* Because the heat of rejection varies during the ice making cycle, the figure shown is an average.

** Peak figure is to be used for sizing cooling towers.

MOUNTING SINGLE ICE MACHINE ON STORAGE BIN

1. Move the bin into final position.
2. Level the bin to assure bin door closes and seals properly. Turn the "foot" of the appropriate leg(s) to level bin. Use level on bin top, Figure 2.

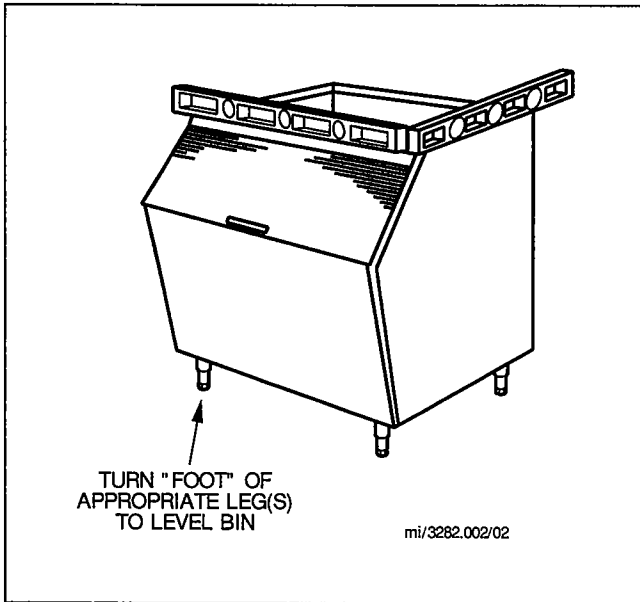

FIGURE 2. LEG ADJUSTMENT

3. Set the ice machine on the bin, aligning the sides and back of the ice machine with the sides and back of the bin. Take care not to tear or dislodge the mounting gasket.
4. Loosen two screws holding front panel in place and remove front panel.
5. Carefully remove tape holding instructions envelope (and air baffle — air-cooled models only) to water curtain. Install air baffle per instructions on baffle.

MOUNTING TWO ICE MACHINES ON STORAGE BIN

A K00014 stacking kit is required for stacking two G400 ice machines. Installation instructions are supplied with the kit.

NOTE

The G400 ice machine can be stacked with other models of Manitowoc ice machines and on a variety of Manitowoc bins. Consult your Manitowoc dealer or distributor for more information.

ELECTRICAL SERVICE (Figure 3)

CAUTION

All wiring must conform to local, state and national codes.

Voltage — 115V, 60 Hertz, 1 Phase

Provide a separate fused circuit for each ice machine. The maximum allowable voltage variation is $\pm 10\%$ of the rated voltage at ice machine start-up (when the electrical load is highest).

WARNING

This ice machine requires a ground that meets the National and Local Electrical Code regulations.

Fuse/Circuit Breaker

Air-Cooled	25A
Water-Cooled	20A
Remote	20A

Provide a separate fuse/circuit breaker for each ice machine. Circuit breakers must be H.A.C.R. rated (does not apply in Canada).

Minimum Circuit Ampacity

Air-Cooled	14.9A
Water-Cooled	11.6A
Remote	14.0A

The minimum circuit ampacity is used to help select the wire size of the electrical supply. (It is not the ice machine's running amps.) The wire size, or gauge, is also dependent upon location, materials used, length of run, etc., and therefore must be determined by a qualified electrician.

Connection at Self-Contained Ice Machine

A 1-1/16 inch electrical entrance is provided for routing electrical conduit.

CAUTION

The accompanying diagrams are not intended to show proper wire routing, wire sizing, disconnects, etc., only the correct wire connections. **All electrical connections and routing must conform to local and national codes.**

Refer to Figure 3 for wiring connections for the self-contained ice machines.

Refer to page 8 for proper Remote Ice Machine Installation.

115 Volt, 1 Phase, 60 Hz, Self-Contained

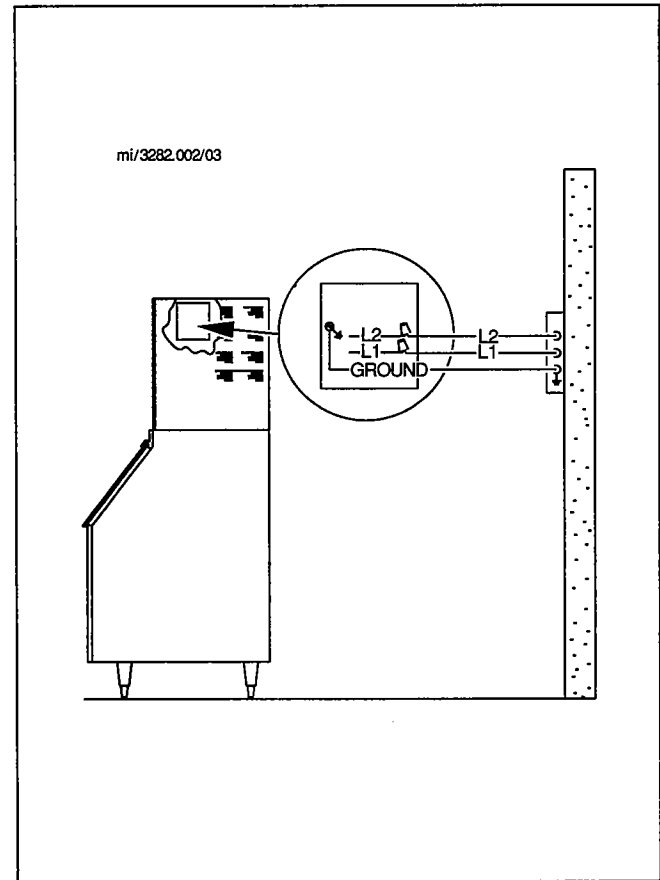

FIGURE 3. SELF-CONTAINED WIRING

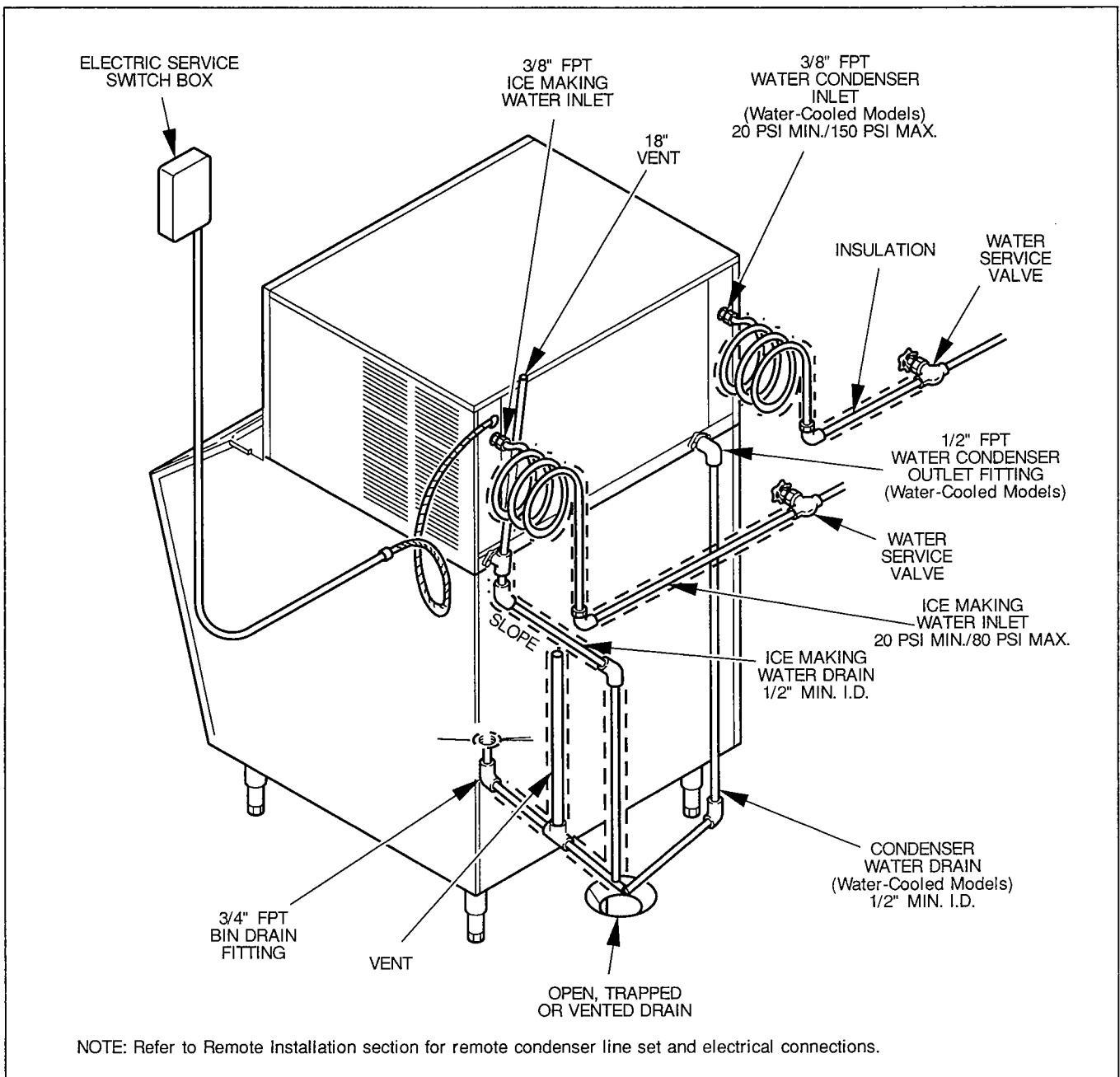

FIGURE 4. SELF-CONTAINED ICE MACHINE INSTALLATION

WATER SERVICE/DRAINS (Figure 4)

CAUTION
Plumbing must conform to local and state codes.

Water Supply

Local water conditions may require the installation of water treatment devices in the ice making water supply line.

If water treatment systems such as deionization, reverse osmosis, or distillation are to be used, contact your Manitowoc distributor for instructions.

Temperature: minimum 33°F, maximum 90°F.

IMPORTANT

The ice machine must not be connected to a hot water supply. Be sure all hot water restrictors (check valves) installed for other equipment (sink faucets, dishwashers, etc.) are in working order.

Ice making water pressure: minimum 20 psi, maximum 80 psi.

If water pressure exceeds maximum psi, obtain a water pressure regulator from your Manitowoc distributor.

Condenser pressure (water-cooled models): minimum 20 psi, maximum 150 psi.

Inlet Water Connections

Ice making water: 3/8 inch F.P.T.

Condenser (water-cooled models): 3/8 inch F.P.T.

Install a shut-off valve for both the ice making and condenser water lines. All water lines should be insulated to prevent condensation.

The ice making water supply is connected to a 3/8 inch female pipe fitting in the rear panel. Use 3/8 inch O.D. tubing.

The condenser water supply is connected to a 3/8 inch female pipe fitting in the rear panel. Use a minimum of 1/2 inch O.D. tubing up to the 3/8 inch fitting.

Drain Connections

Ice making water drain: 1/2 inch F.P.T.

Condenser drain (water-cooled models only): 1/2 inch F.P.T.

Bin drain: 3/4 inch F.P.T.

Use the following guidelines to prevent backflow of drain water into the ice machine and storage bin.

- Drain lines must have 1-1/2 inch drop per 5 feet of run and must not create any traps.
- The floor drain must be sized to accommodate drainage from all drains.
- Run the bin and ice machine drain lines separately and insulate to prevent condensation.
- The ice machine drain lines require a minimum of 1/2 inch I.D. tubing.
- The bin drain line requires a minimum of 3/4 inch I.D. tubing.

- The ice making water drain and bin drain must be vented to the atmosphere. Do not vent condenser drain (water-cooled models).

Water-Cooled Models (Cooling Tower Applications)

A water-cooling tower installation does not require modification to the ice machine; the water regulator valve for the condenser continues to control the refrigeration discharge pressure. It is necessary to know the amount of heat rejection (see page 4) and the pressure drop through the condenser and water valve (inlet and outlet of the ice machine) to apply these types of systems to the ice machine.

- Water entering the condenser must not exceed 90°F.
- Water flow through the condenser must not exceed 5 GPM.
- Allow for a pressure drop of 7 psi between the condenser water inlet and outlet of the ice machine.
- Condenser water exiting temperature must not exceed 110°F.

REMOTE ICE MACHINE INSTALLATION

IMPORTANT

Failure to follow installation guidelines may affect warranty coverage.

General Information

Ice Machine	Remote Single Condenser	Remote Dual Condenser	Line Set
GR-0490N	AC-0496B	DC-0496A	RT-**-502
GD-0492N	AC-0496B	DC-0496A	RT-**-502
GY-0494N	AC-0496B	DC-0496A	RT-**-502

Line set size: Discharge 1/2"
Liquid 3/8"

The remote model ice machines are used in conjunction with a remoted air condenser and corresponding line set number. The ** in the line set model number represents line length. Line sets are available in 20', 35' and 50' lengths.

The single circuit condensers are used for single ice machine installations. Dual circuit condensers have 2 sets of connections for the installation of two ice machines together with one remoted package.

NOTE

The dual circuit condenser can be used for single ice machine installations with the anticipation of installing another ice machine at a later date.

Ice Machine Set-Up

Follow the standard installation specifications on water supply, drain lines and electrical requirements, pages 5 and 6.

The following guidelines cover remote condenser installation (line set routing, etc.), and remote ice machine and condenser electrical connections.

Remote Air Condenser Assembly

Refer to Figure 5.

On a single circuit condenser (AC models) condenser legs attach to provide 12, 16 or 20 inch clearance under the condenser. Dual circuit condensers provide for 3.5, (no legs attached) 8, 12, 16 or 20 inch clearance. 20" clearance is to be used in installation where heavy snow or debris may collect at base of condenser causing air flow restrictions.

NOTE

The condensers are equipped with six mounting holes in the base of the legs. Refer to dimension illustration, page 2.

Dimensions referred to are distance from mounting surface to bottom of condenser. How to secure the remote condenser to final location is determined by installation.

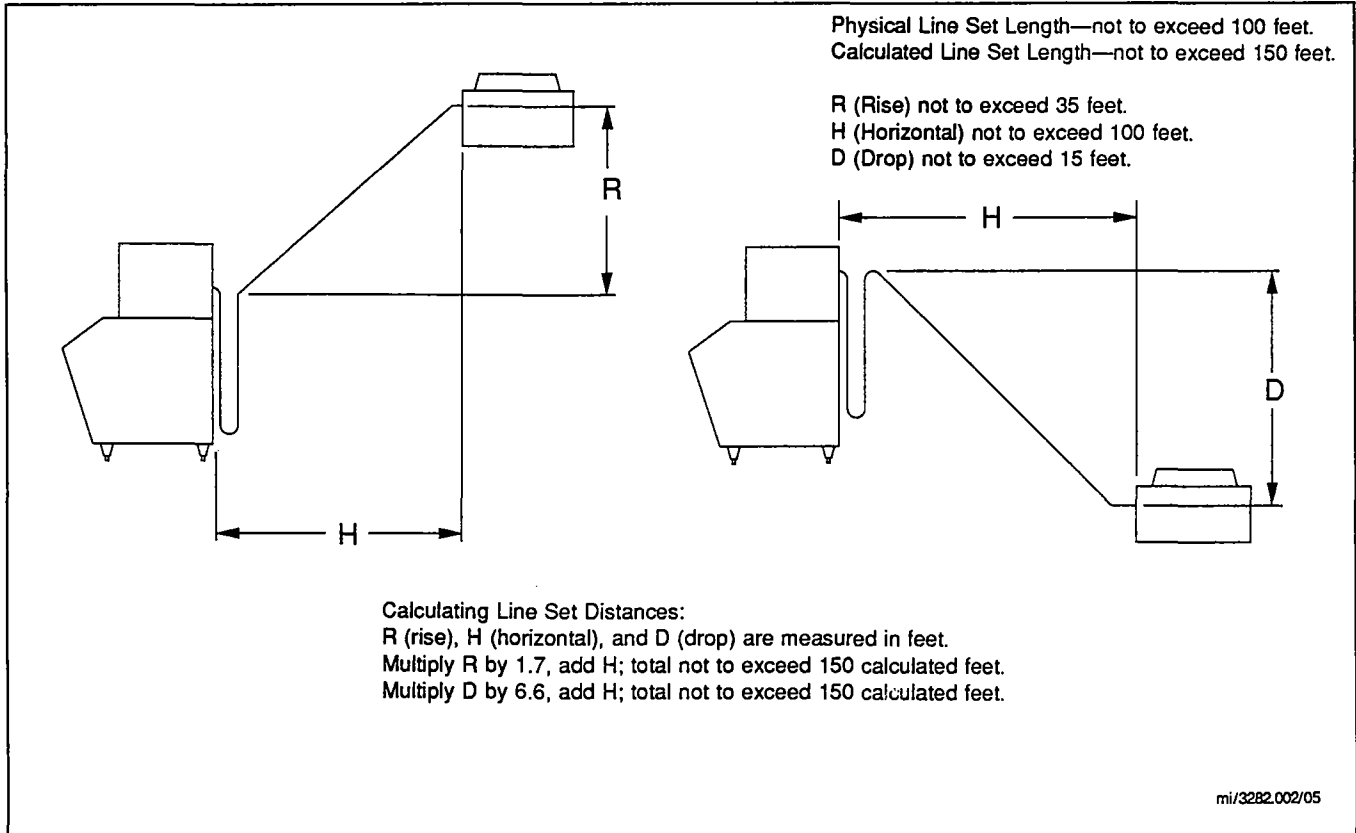

FIGURE 5. CALCULATING LENGTH OF LINE SETS

Location of Remote Condenser

The following practices must be followed to ensure proper performance of the ice machine and that warranty coverage is not voided. (See Typical Remote Installations, Figures 5 and 6).

Air temperature around condenser — minimum -20°F, maximum 120°F.

Must use approved condenser and line set sizes.
Maximum physical line set length — 100 ft.

Maximum vertical rise — 35 ft.

Maximum vertical drop — 15 ft.

Maximum calculated line set length — 150 ft. (refer to page 9).

Routing of line set must not form traps (Figure 6).

Condensers must be mounted horizontally with condenser fan motor on top (Figure 7).

Routing of Line Sets (Figure 6)

The following practices must be followed when routing refrigerant lines to ensure proper performance and service accessibility to the ice machine.

IMPORTANT

On dual circuit condensers circuits are labeled 1 and 2. Mark or tag line sets 1 and 2 before running to prevent crossing of refrigeration systems.

AC Condensers — a 2-1/2" hole in wall or roof is needed for tubing routing.

DC Condensers — a 4" hole in wall or roof is needed for tubing routing.

1. Make service loop in line set provided so that the ice machine can be pulled away from the wall.
2. The line set must slope downward toward the ice machine or condenser. Never form a trap in the discharge line as refrigerant oil must be free to drain toward the ice machine or condenser. The service loop is part of the ice machine's design.
3. Outside line set length must be as short as possible.

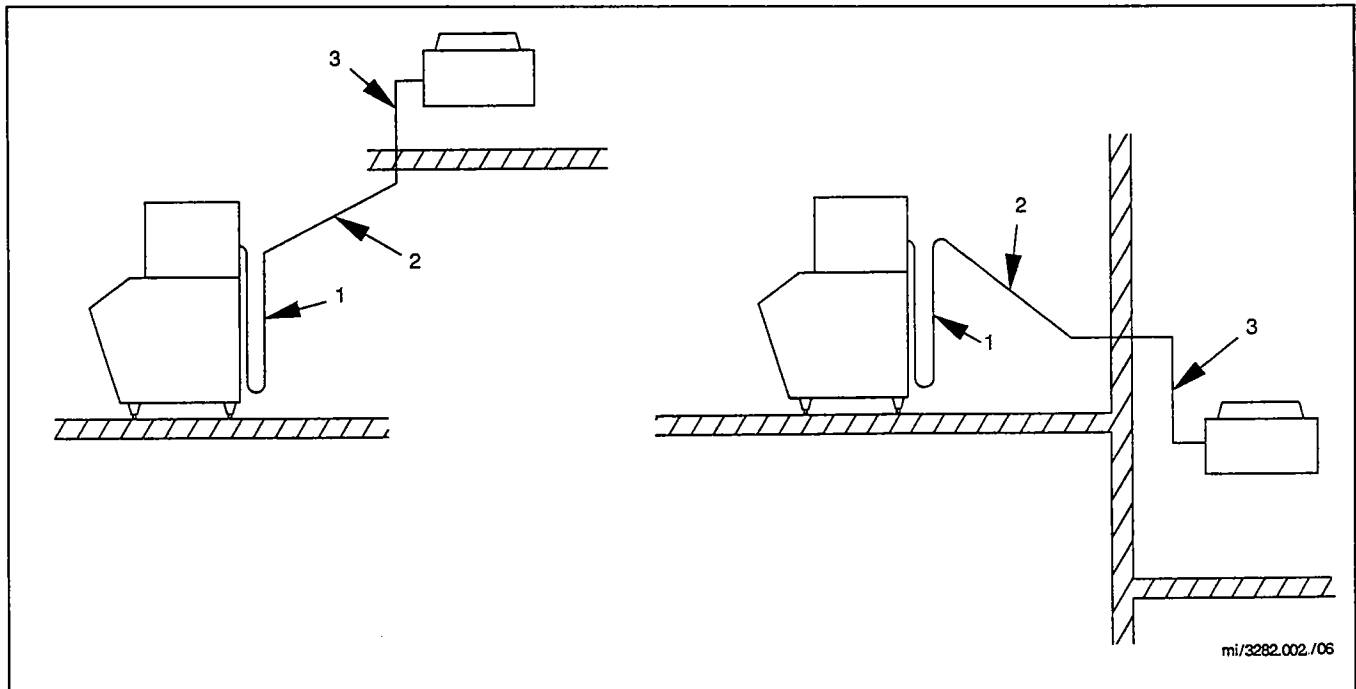

FIGURE 6. ROUTING OF LINE SETS

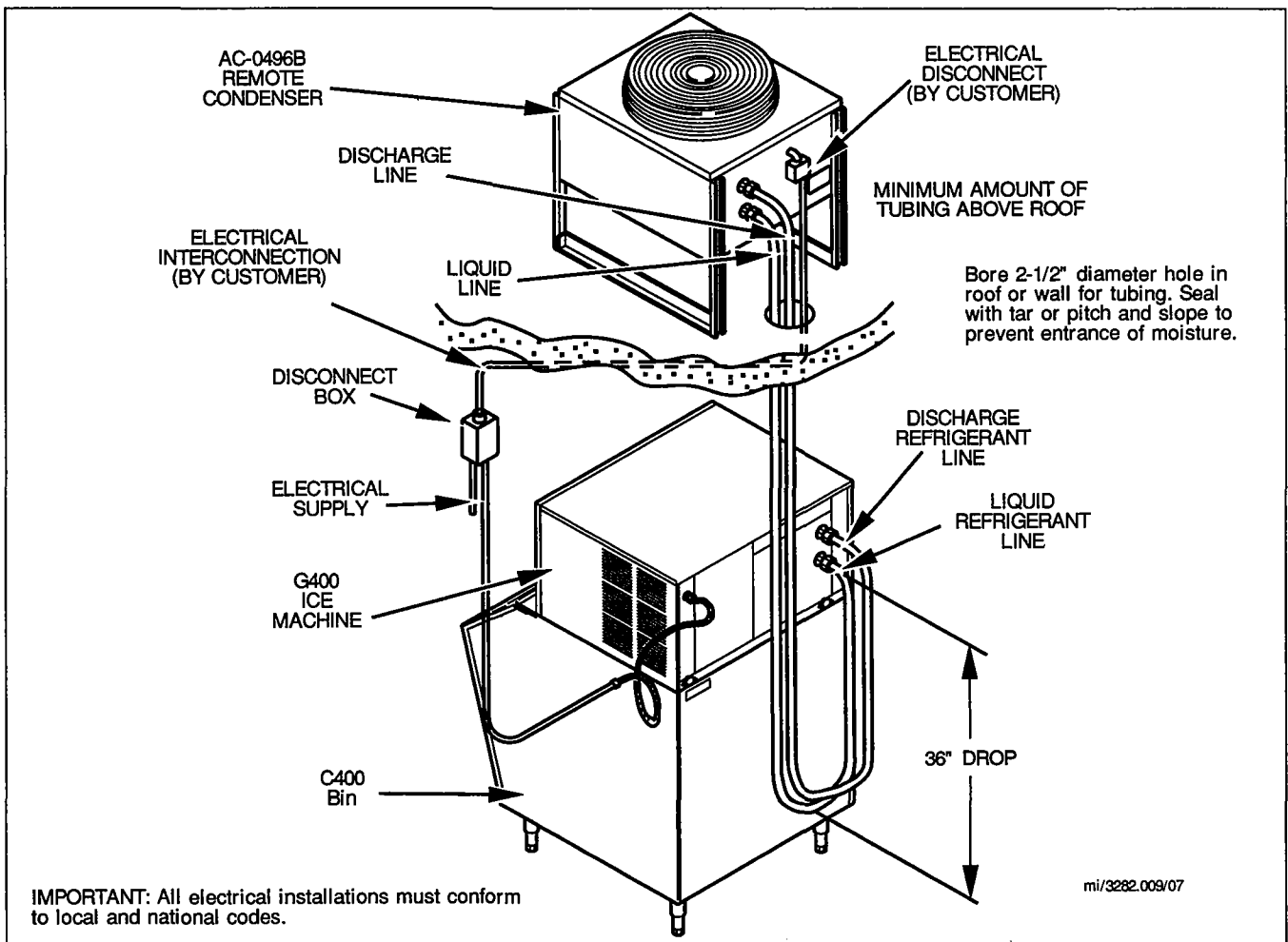

FIGURE 7. LINE SET CONNECTIONS FOR SINGLE (AC) CONDENSER

Connection of Line Set (Figures 7 and 8)

1. Remove dust caps from line set, condenser and ice machine.
2. Apply refrigeration oil to the threads on the quick disconnect couplers before connection to the condenser.

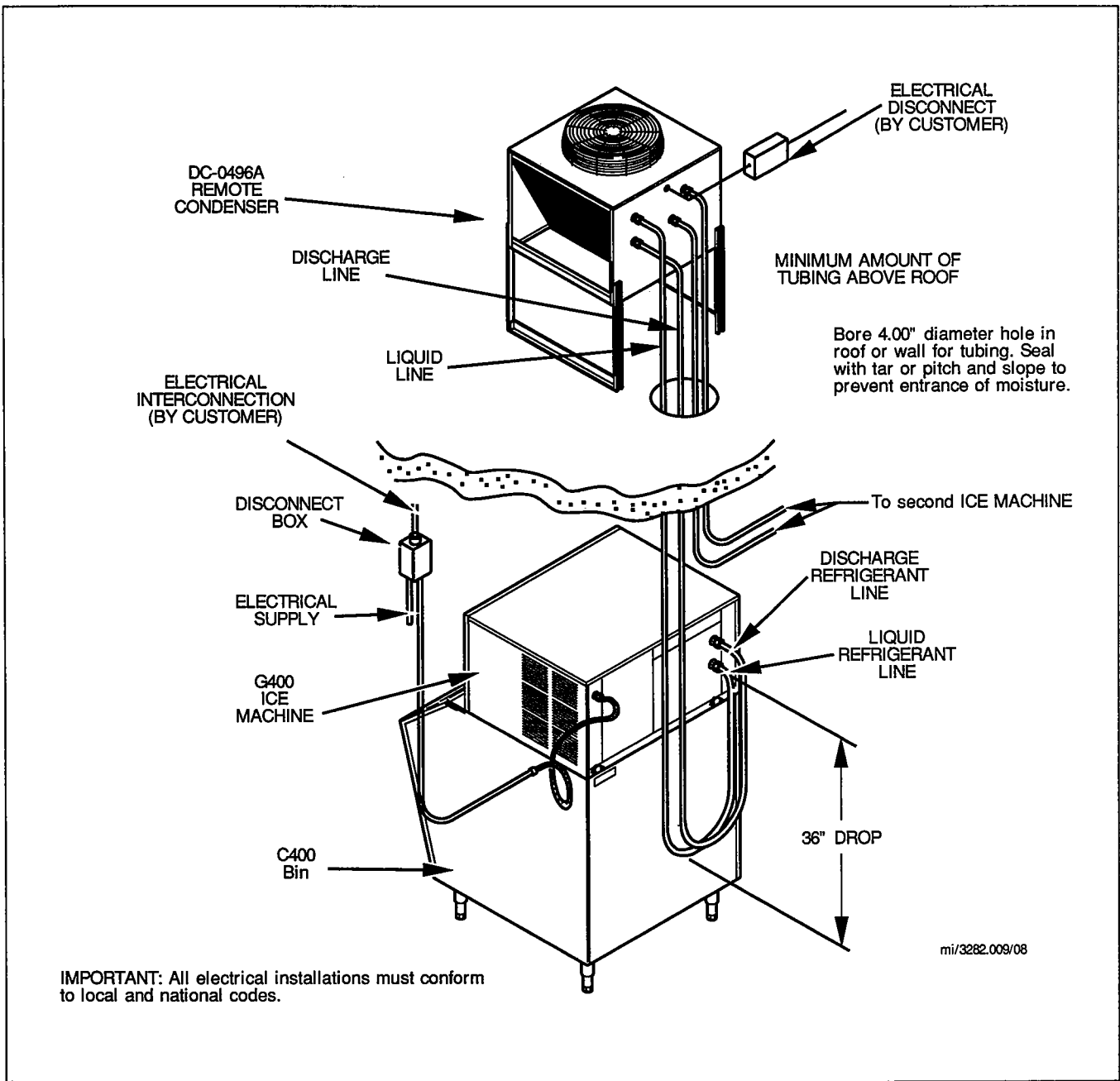

FIGURE 8. LINE SET CONNECTIONS FOR DUAL (DC) CONDENSER

3. Carefully thread by hand, the female fitting on to the condenser or ice machine.
4. Using proper size wrench, tighten couplings until they bottom out. Then add 1/4 turn to ensure proper brass-to-brass seating. (If a torque wrench is used: liquid line — 10-12 ft. lbs.; discharge line — 35-45 ft. lbs.).

5. Leak check all fittings.

CAUTION

If it is necessary to remove the connecting couplers, remove all refrigerant from the ice machine before attempting to remove the couplers from the ice machine or remote condenser.

Remote Ice Machine Electrical Hook-Up

Refer to page 3 for fuse/circuit breaker size and minimum circuit ampacity.

An electrical disconnect (supplied by installer) must be installed at condenser. A 7/8 inch hole is provided at condenser for electrical connection.

CAUTION

The diagrams are not intended to show proper wire routing, wire sizing, disconnects, etc., only the proper wire connections. All electrical connections and routing must conform to local and national codes.

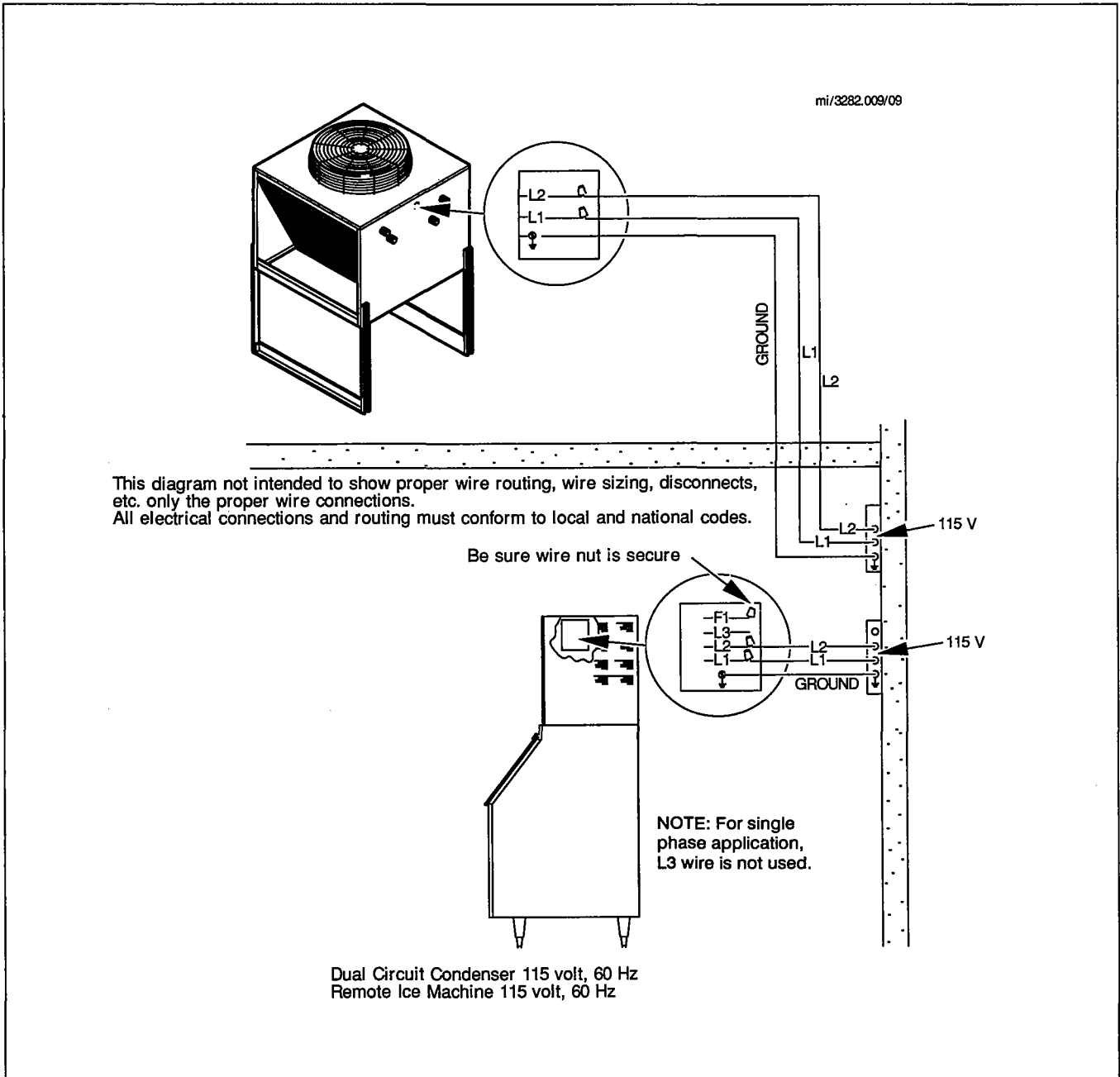

FIGURE 9. ELECTRICAL CONNECTIONS FOR DUAL (DC) CONDENSER

**Dual Circuit Condensers
DC Models (Figure 9)**

All DC condensers require a separate 115V/60Hz power supply. The condenser fan will run continuously.

NOTE

When wiring a remote condenser to a separate power source, the F1 lead in the ice machine is **not used** and must have a wire nut securely fastened to it.

CAUTION

All DC model remote condensers are 115V. Do not wire directly to 230V ice machines.

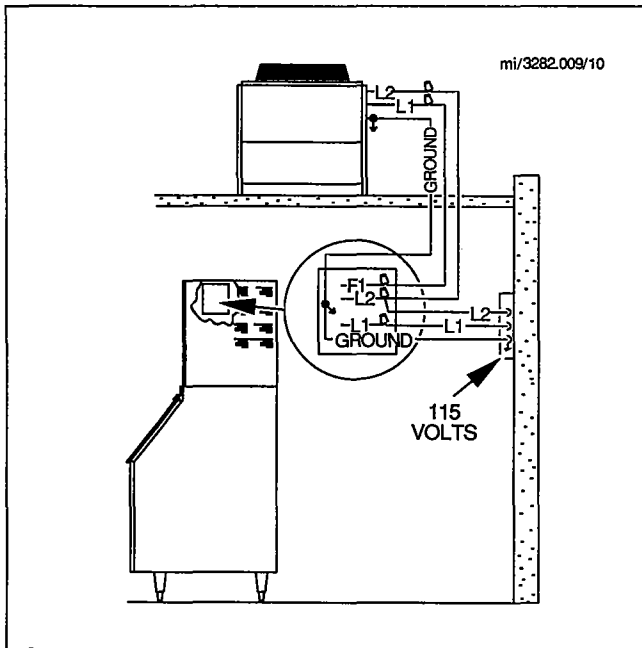

**FIGURE 10. SINGLE CIRCUIT CONDENSER
(AC) WIRING**
Condenser - 115 Volts
Remote Ice Machine - 115 Volt, 1 Phase, 60 Hz

**Single Circuit Condensers
AC Models (Figure 10)**

The single circuit condenser requires a 115V power supply which can be wired directly to the ice machine. The condenser fan will run only when the ice machine is operating.

NOTE

The single circuit (AC) condenser may be connected similar to the dual circuit (DC) condenser with separate power.

Receiver Service Valve (Figure 11)

The receiver service valve is closed during shipment. Open prior to starting the ice machine as follows.

1. Remove back panel.
2. Remove receiver service valve cap.
3. Backseat (open) valve.
4. Reinstall cap and back panel.

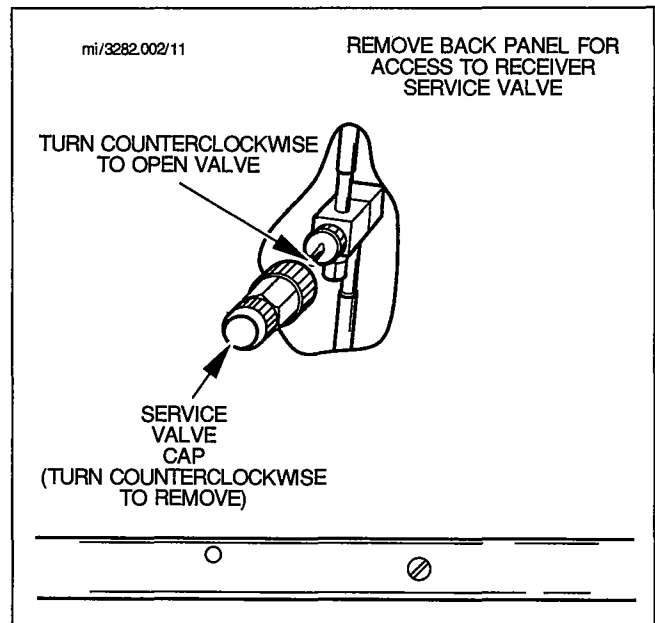

**FIGURE 11. BACKSEATING RECEIVER
SERVICE VALVE**

INSTALLATION CHECK LIST

- Is ice machine level?
- Has all the internal packing been removed?
- Have all the electrical and water connections been completed?
- Has the supply voltage been tested and checked against the rating on the nameplate?
- Is there a minimum of 5 inches clearance around the ice machine for proper air circulation?
- Has air baffle been installed on air-cooled models?
- Is the ice machine installed where ambient temperatures will not vary below 35°F or above 110°F? Incoming water temperature range 33°F/90°F? (See Owner/Operator Use and Care Guide for winterizing.)

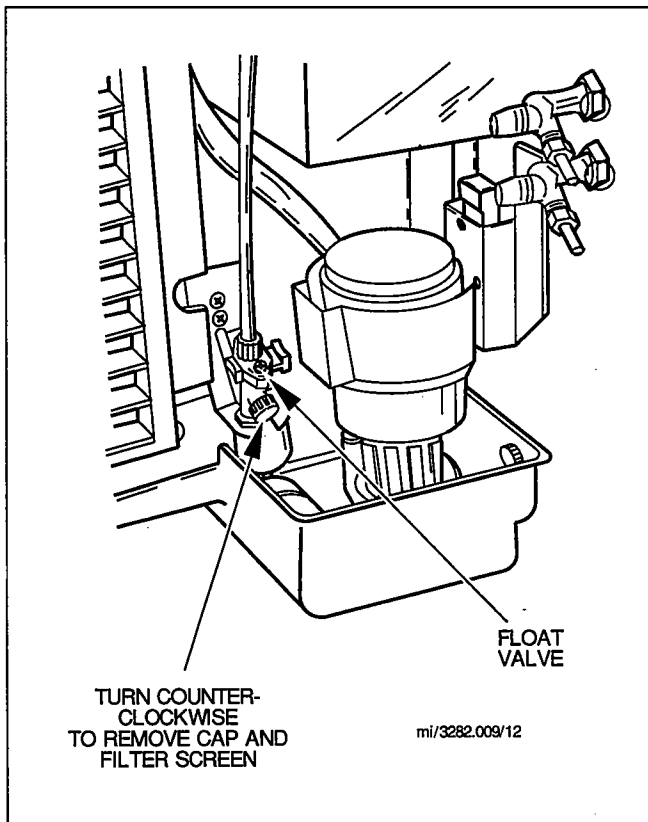

FIGURE 12. CLEANING FLOAT VALVE FILTER SCREEN

- Is there a separate drain for the water-cooled condenser?
- Are ice machine and bin drains vented?
- Are all electrical leads free from contact with refrigeration lines and moving components?
- Has filter screen in float valve been cleaned? See Figure 12.
- Has owner/operator been instructed regarding maintenance procedures and the use of Manitowoc Cleaner and Sanitizer?
- Has owner/operator completed the warranty registration card?
- Has Owner/Operator Use and Care Guide been left with owner/operator?
- Was bin and ice machine sanitized?

Additional Ice Machine Checks for Remote Models

- Has receiver service valve been opened?
- Does the remote condenser fan operate properly? (After start-up.)
- Is remote condenser located where ambient temperatures will not vary below -20°F or above +120°F?

BEFORE STARTING ICE MACHINE

All Manitowoc Ice Machines are factory operated and adjusted before shipment. Normally no adjustments are necessary for new installation.

To ensure proper operation, follow the OPERATIONAL CHECK in the Owner/Operator Use and Care Guide.

Starting the ice machine and completing OPERATIONAL CHECK is the responsibility of the owner/installer. Adjustments and maintenance as outlined in the Owner/Operator Use and Care Guide are not covered by warranty.

MANITOWOC ICE, INC.

2110 South 26th Street P.O. Box 1720

Manitowoc, WI 54221-1720

Phone: (920) 682-0161

Fax: (920) 683-7585

Web Site: www.manitowocice.com

© 1999 Manitowoc Ice, Inc.

Litho in U.S.A.