

# Manitowoc<sup>®</sup> ICE MACHINES

## Series G200/G400

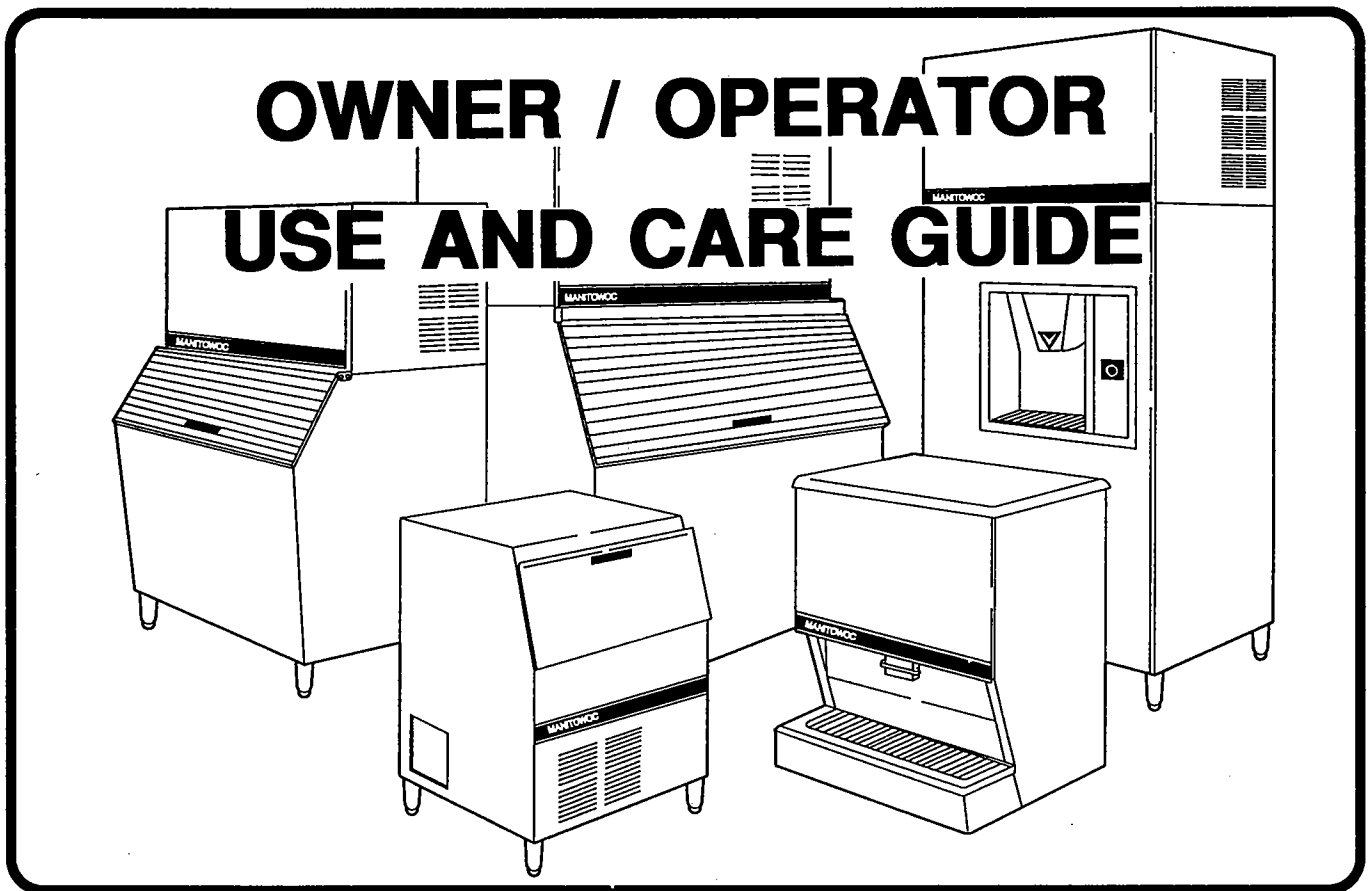

Thank you for selecting a Manitowoc Ice Machine, the dependability leader in ice making equipment and related products. With proper care and maintenance, your new Manitowoc Ice Machine will provide you with many years of reliable and economic performance.

This product qualifies for the following listings:



We reserve the right to make product improvements at any time. Specifications and design are subject to change without notice.



Part No. 80-0836-3  
Rev. 1 7-92



# IMPORTANT

Proper care and maintenance are essential for maximum ice production and trouble-free operation of your Manitowoc Ice Machine.

You should read and understand this Use and Care Guide as it contains valuable care and maintenance information.

If you encounter problems not covered by this guide, please contact your local Manitowoc dealer or distributor for service information.

---

Your Use and Care Guide covers the following model numbers:

<b>Air Cooled</b>	<b>Water Cooled</b>	<b>Remote</b>
GR0200A	GR0201W	GR0490N
GD0202A	GD0203W	GD0492N
GY0204A	GY0205W	GY0494N
GR0400A	GR0401W	
GD0402A	GD0403W	
GY0404A	GY0405W	

# TABLE OF CONTENTS

## SECTION 1 — GENERAL INFORMATION

Model/Serial Numbers Location . . . . .	1
Owner Warranty Registration Card . . . . .	2
About Your Warranty . . . . .	2

## SECTION 2 — ABOUT YOUR ICE MACHINE

Component Location and Identification . . . . .	3
Sequence of Operation . . . . .	4
Freeze Sequence . . . . .	4
Harvest Sequence . . . . .	4
Automatic Stop and Start . . . . .	4
Operational Checks . . . . .	5
Water Level Check . . . . .	5
Water Curtain Check . . . . .	5
Bin Switch Check . . . . .	6
Ice Thickness Check . . . . .	6

## SECTION 3 — MAINTENANCE

Maintenance Guidelines . . . . .	7
General Ice Machine Inspection . . . . .	8
Exterior Cleaning . . . . .	8
Cleaning the Condenser . . . . .	8
Air-Cooled Condenser . . . . .	8
Water-Cooled Condenser . . . . .	9
Interior Cleaning . . . . .	9
Removal of Parts for Cleaning . . . . .	9
Remove Water Pump . . . . .	9
Remove Float Valve . . . . .	10
Remove Distribution Tube . . . . .	10
Disassemble Distribution Tube . . . . .	10
Remove Ice Thickness Probe . . . . .	11
Remove Water Trough . . . . .	11
Cleaning Procedures . . . . .	11
Clean the Evaporator Surface . . . . .	12
Sanitizing . . . . .	12
Checking and Cleaning the Water Dump Valve . . . . .	13
Operation Check . . . . .	13
Remove Water Dump Valve . . . . .	13
Disassemble Water Dump Valve . . . . .	13
Cleaning Water Dump Valve . . . . .	14
Water Filtration . . . . .	14
Replacement Procedure . . . . .	14
Removal from Service/Winterization . . . . .	15

## SECTION 4 — BEFORE CALLING FOR SERVICE

Checklist . . . . .	16
---------------------	----

**MANITOWOC EQUIPMENT WORKS**  
Division of The Manitowoc Company, Inc.  
2110 South 26th Street, P.O. Box 1720, Manitowoc, WI 54221-1720 U.S.A.  
Telephone 414-682-0161  
RCA Telex 297863 MANCO-UR  
FAX 414-683-7879

# SECTION 1 GENERAL INFORMATION

## MODEL/SERIAL NUMBERS LOCATION

Record the model and serial numbers of your ice machine and bin or dispenser in the space provided below for your convenience. These numbers are required when requesting information from your local Manitowoc distributor, service representative, or Manitowoc Equipment works.

The model and serial numbers are listed on the OWNER WARRANTY REGISTRATION CARD, and on the MODEL/SERIAL NUMBERS DECAL affixed to the inside of the ice machine and on the back panel of the bin, Figure 1.

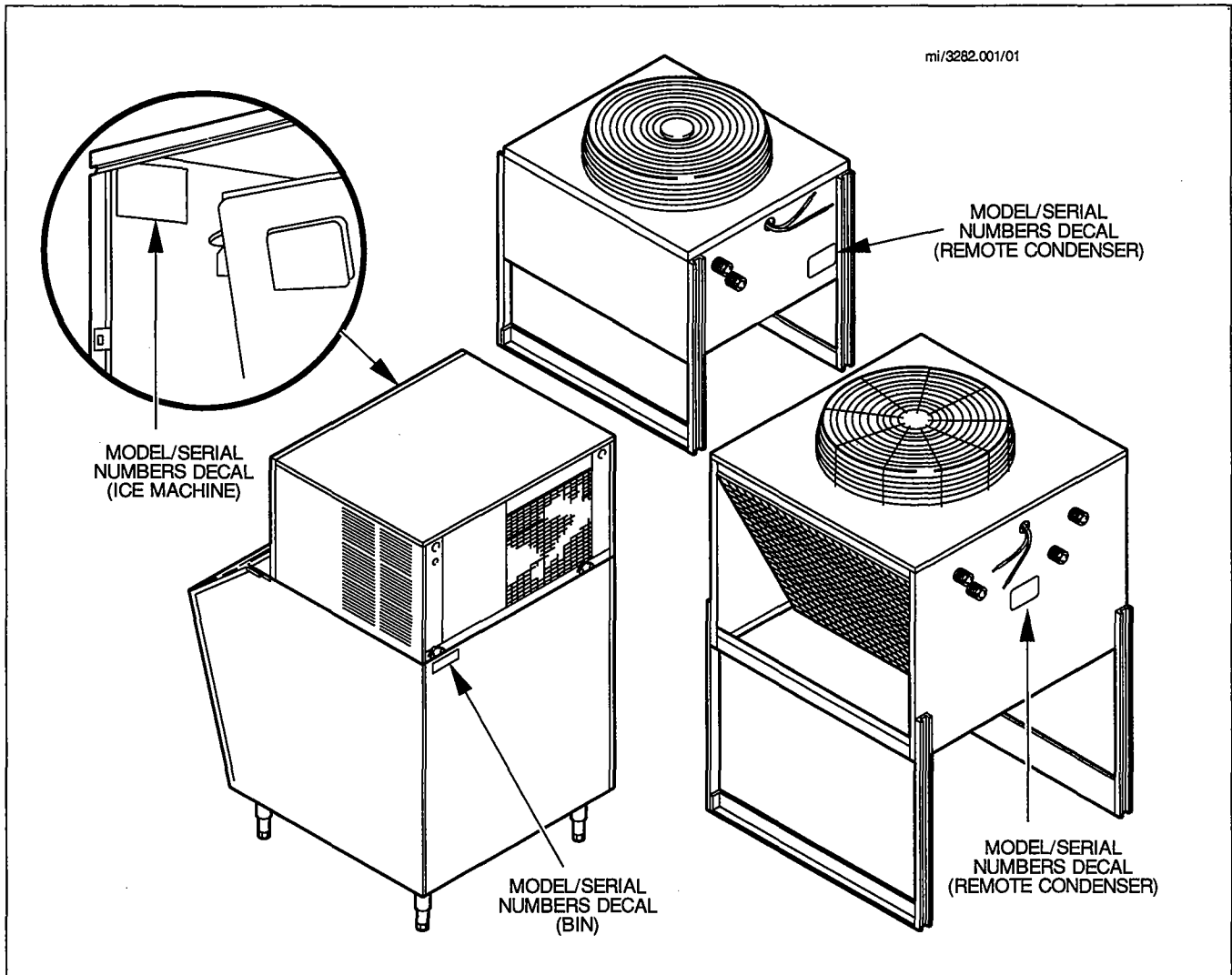

**FIGURE 1. MODEL/SERIAL NUMBER LOCATION**

	<b>ICE MACHINE</b>	<b>BIN OR DISPENSER</b>	<b>REMOTE CONDENSER</b>
MODEL NUMBER	_____	_____	_____
SERIAL NUMBER	_____	_____	_____

## **OWNER WARRANTY REGISTRATION CARD**

The packet containing this guide also includes warranty information. Warranty coverage begins the day your new ice machine is installed.

### **IMPORTANT**

To validate the installation date, fill in the OWNER WARRANTY REGISTRATION CARD and mail it as soon as possible.

If your card is not returned, Manitowoc will use the date of sale to the Manitowoc Distributor as the first day of warranty coverage for your new ice machine.

### **About Your Warranty**

For your convenience, the warranty statement is duplicated on the back cover of this guide.

Contact your local Manitowoc representative or our Wisconsin headquarters for further warranty information.

## **WARRANTY COVERAGE**

**(Effective for Ice Machines Installed after January 1, 1991)**

### **Parts**

1. Your ice machine is warranted against defects in materials and workmanship under normal use and service for three (3) years from the date of the original installation. It is important to send in your warranty registration card so Manitowoc can begin your warranty on the installation date.
2. An additional two (2) years (five years total) warranty is provided on evaporator and compressor from the date of original installation.

### **Labor**

1. Labor allowance to repair or replace defective components is for three (3) years from the date of original installation.
2. An additional two (2) years (**five (5) years total**) labor warranty is provided on the evaporator from date of original installation.

## **Exclusions from Warranty Coverage**

The following items are not included in the warranty coverage of your ice machine.

1. Normal maintenance, adjustments and cleaning as outlined in this manual.
2. Repairs due to unauthorized modifications to the ice machine or the use of nonapproved parts without written approval from Manitowoc Equipment Works.
3. Damage from improper installation as outlined in the Installation Instructions, improper electrical supply, water supply or drainage; flood, storms, or other acts of God.
4. Premium labor rates due to holidays, overtime, etc. Travel time, flat rate service call charges, mileage and miscellaneous tools and material charges not listed on the payment schedule are excluded as well as additional labor charges resulting from inaccessibility of the ice machine.
5. Parts or assemblies subjected to misuse, abuse, neglect or accidents.
6. When the ice machine has been installed, cleaned and/or maintained inconsistent with the technical instructions provided in this Owner/Operator Use and Care Guide and the Installation Manual.

## **Authorized Warranty Service**

To comply with the provisions of the warranty a refrigeration service company qualified and authorized by your Manitowoc distributor or a Contracted Service Representative must perform the warranty repair.

### **NOTE**

If the dealer you purchased the ice machine from **IS NOT** authorized to perform warranty service, contact your Manitowoc distributor or our Wisconsin headquarters for the name of the nearest authorized service representative.

## **Service Calls**

Service for your ice machine should be applied if, after the procedures listed in this guide have been implemented, the condition of your ice machine has not improved.

# SECTION 2 ABOUT YOUR ICE MACHINE

## COMPONENT LOCATION AND IDENTIFICATION

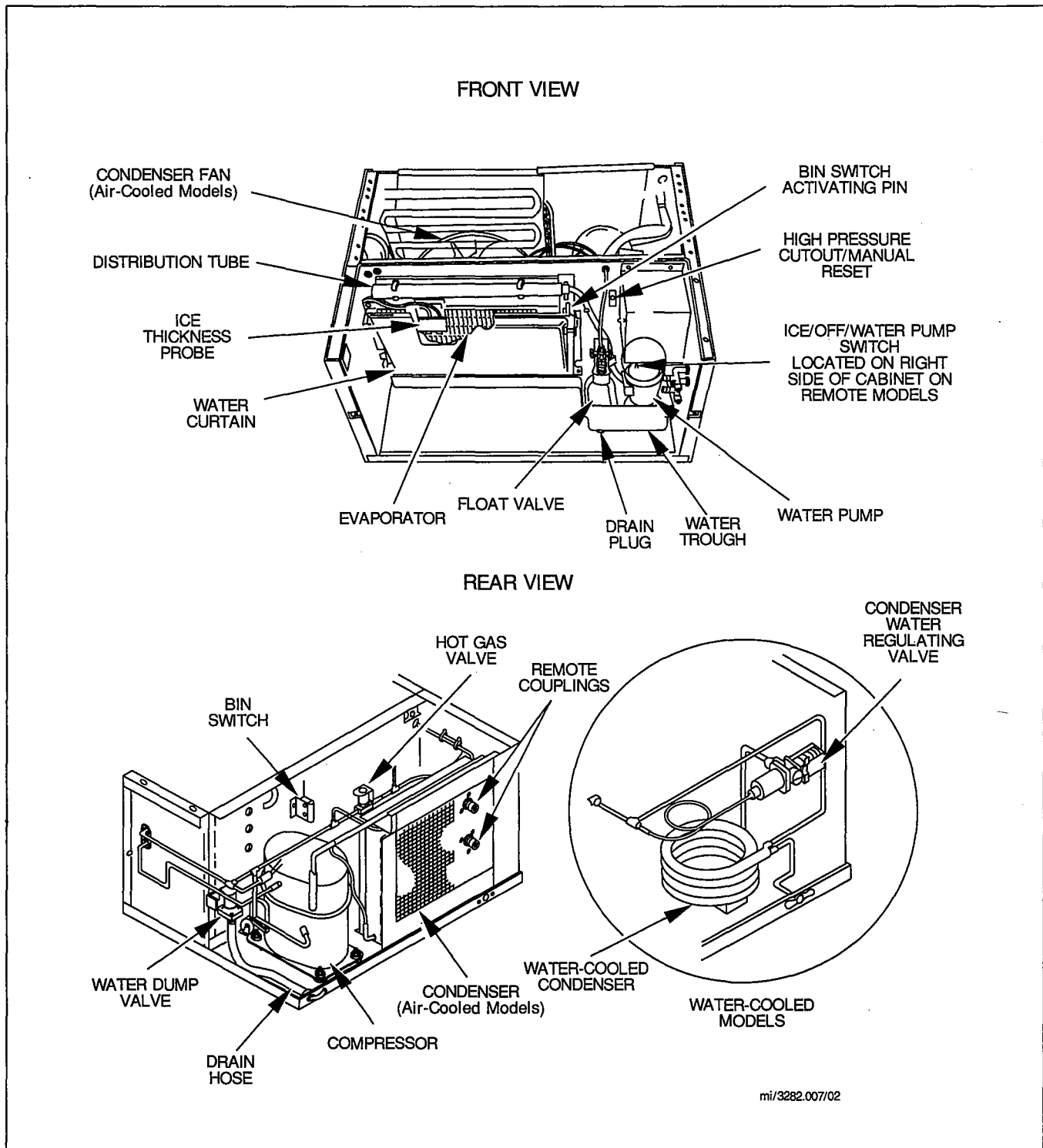

**FIGURE 2. COMPONENT LOCATION**

## SEQUENCE OF OPERATION

### Freeze Sequence (Figure 3)

When the ICE/OFF/WATER PUMP switch is set at ICE, the compressor and the condenser fan (air-cooled models) start. On remote models the compressor and the condenser fan start after a momentary delay.

The water pump **will not** start for approximately 20 seconds. This allows the evaporator to "prechill."

Upon completion of the PRECHILL OF THE EVAPORATOR the water pump pumps water from the water trough up through the distribution tube. The distribution tube directs an even flow of water down across the front of the evaporator. Water flows into each cube mold, gradually building ice. The water which flows back into the water trough is recirculated. The float valve maintains the proper water level in the trough.

### Harvest Sequence (Figure 4)

As ice builds in the evaporator to the proper thickness, water flowing over the ice comes in contact with the ice thickness probe. This initiates the HARVEST sequence. The hot gas solenoid valve opens diverting hot gas into the evaporator. The water dump valve opens, allowing the water pump to flush mineral deposits from the water trough out the drain. As the hot gas warms the evaporator, the ice cubes slide, as a unit, off the evaporator into the ice storage bin or dispenser. The falling ice swings the bottom of the water curtain out, activating a bin switch. The bin switch de-energizes the hot gas valve, returning the ice machine to the freeze sequence.

### Automatic Stop and Start (Figure 5)

When the ice storage bin becomes full, the last harvesting ice cubes do not completely clear the water curtain, holding it open. The bin switch shuts the ice machine off until sufficient ice is removed from the bin, allowing ice to clear the water curtain. On remote models, the ice machine will run momentarily before shutting off. The return of the water curtain activates the bin switch, putting the machine back into the freeze sequence.

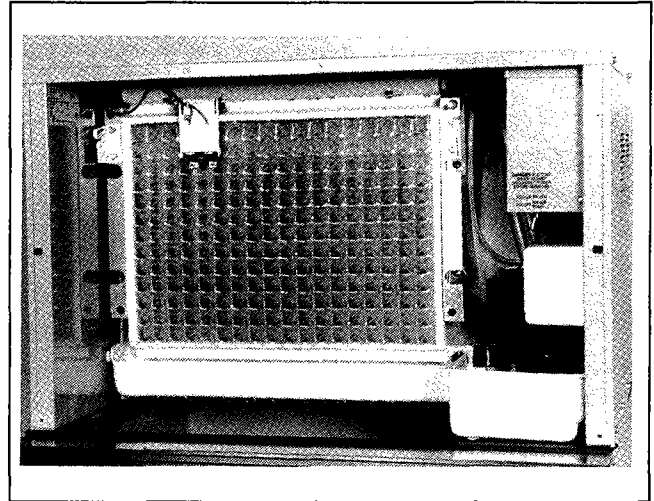

FIGURE 3. FREEZE MODE

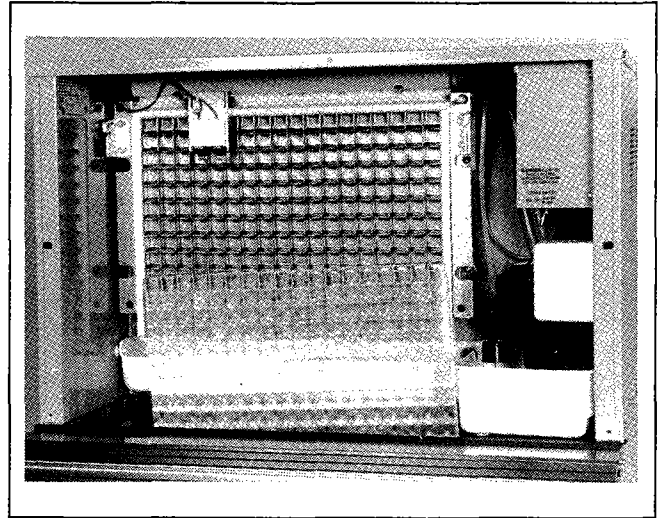

FIGURE 4. HARVEST MODE

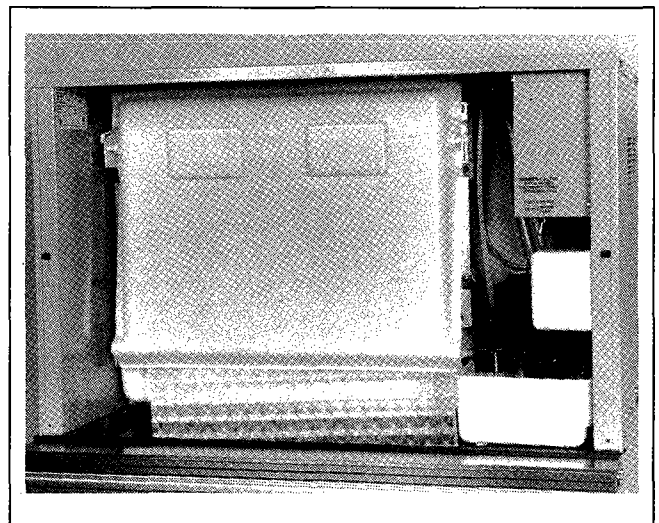

FIGURE 5. AUTOMATIC START/STOP

## OPERATIONAL CHECKS

### IMPORTANT

Follow the Operational Checks when starting the ice machine after initial installation, prolonged "out of service" periods, and after cleaning and sanitizing to ensure proper operation.

Your Manitowoc ice machine is factory operated and adjusted before shipment. Normally no adjustments are necessary for new installations. Adjustments and maintenance as outlined in this guide are not covered by warranty. To check and adjust (if necessary), proceed as follows:

### Water Level Check (Figure 6)

1. Set ICE/OFF/WATER PUMP switch at OFF.

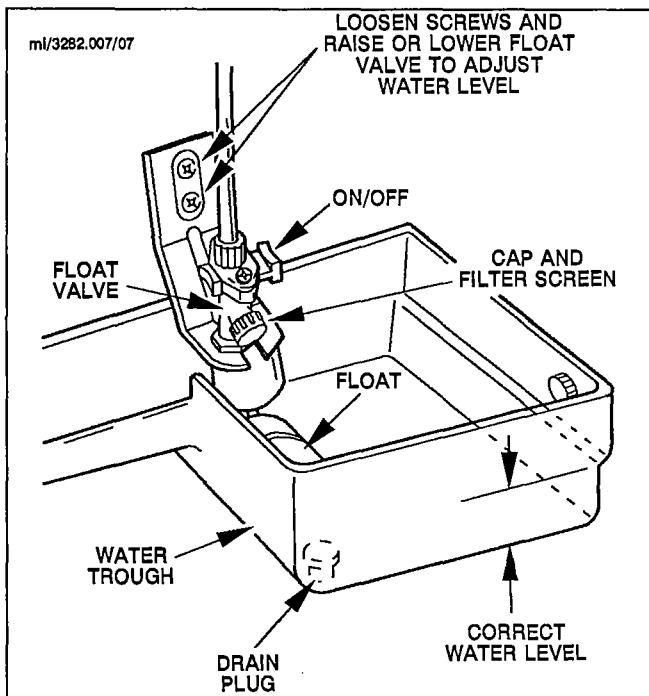

**FIGURE 6. WATER LEVEL CHECK  
(G200 MODELS SHOWN)**

2. Remove drain plug from trough and allow water to drain.
3. Reinstall drain plug on trough and allow trough to refill to proper level.

The float valve is factory set for proper water level. If adjustment is necessary, adjust as follows:

- a. Loosen two screws on float valve bracket.
- b. Raise or lower float valve assembly, then tighten screws.
- c. If further adjustment is necessary, carefully bend float arm to achieve correct level.

### Water Curtain Check (Figure 7)

1. Pull bottom of water curtain away from evaporator, then release. Curtain should fall back to evaporator.

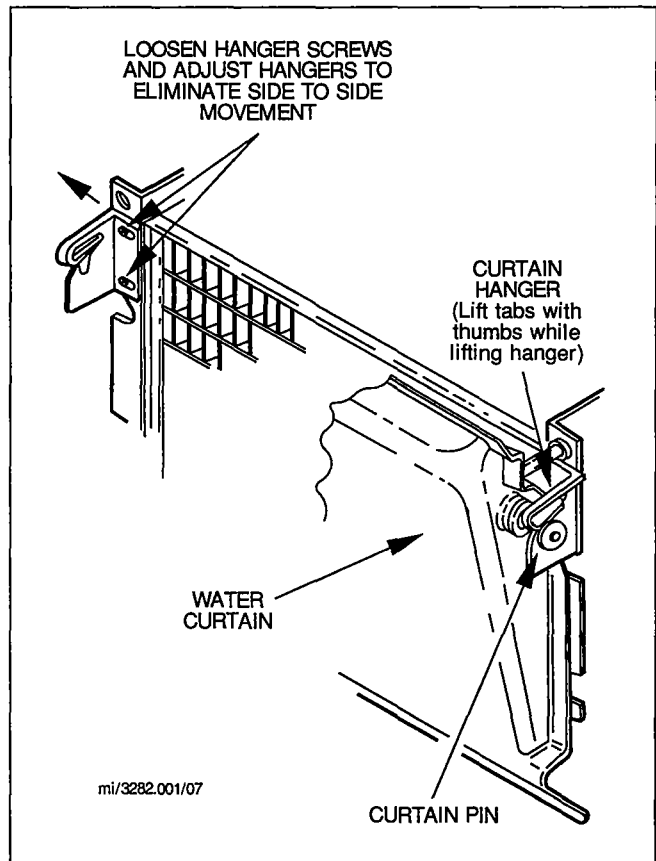

**FIGURE 7. WATER CURTAIN CHECK**

2. Move curtain from side to side. There should be little or no movement.

The water curtain is factory set and should require no adjustment. If adjustment is necessary, adjust as follows:

- a. Remove water curtain.
- b. Loosen curtain hanger screws (two per hanger) and slide hangers out to prevent side to side movement.
- c. Retighten curtain hanger screws.
- d. Reinstall water curtain.

### NOTE

Water curtain pin heads must be positioned under curtain hanger tabs. Curtain must be centered on evaporator when reinstalled.

### Bin Switch Check (Figure 8)

1. Pull water curtain away from evaporator until ice machine shuts off.

#### NOTE

Curtain must be held open for approximately 10 seconds before the machine shuts off. On remote models the ice machine may run 20 to 30 seconds before shutting off.

2. Slowly return curtain to evaporator. Ice machine should restart as bottom edge of water curtain passes just inside edge of water trough.

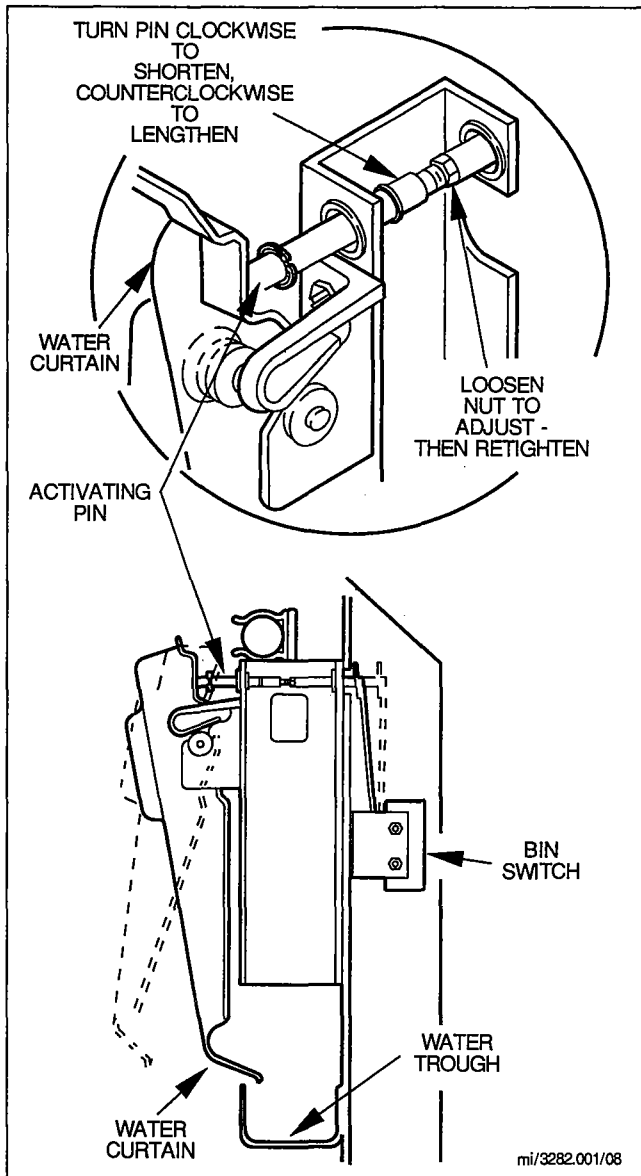

FIGURE 8. BIN SWITCH CHECK

The bin switch is factory set and should not require adjustment. If bin switch adjustment is necessary, adjust as follows:

- a. Set ICE/OFF/WATER PUMP switch at OFF.
- b. Slowly pull bottom of water curtain away from evaporator until bin switch clicks, then slowly return curtain toward evaporator.
- c. If bin switch clicks before water curtain reaches water trough, lengthen the bin switch activating pin.
- d. IF bin switch clicks too far into evaporator, shorten the bin switch activating pin.
- e. Set ICE/OFF/WATER PUMP switch at ICE after adjustment is complete.

### Ice Thickness Check (Figure 9)

Be sure the water curtain is in place to prevent water from splashing out of water trough.

Inspect bridge connecting the cubes. The bridge should be approximately 1/8" thick.

The ice thickness probe is factory set to maintain 1/8 inch ice bridge thickness. If adjustment is necessary, adjust as follows:

1. Turn adjustment screw on ice thickness probe clockwise to increase thickness, counterclockwise to decrease thickness.

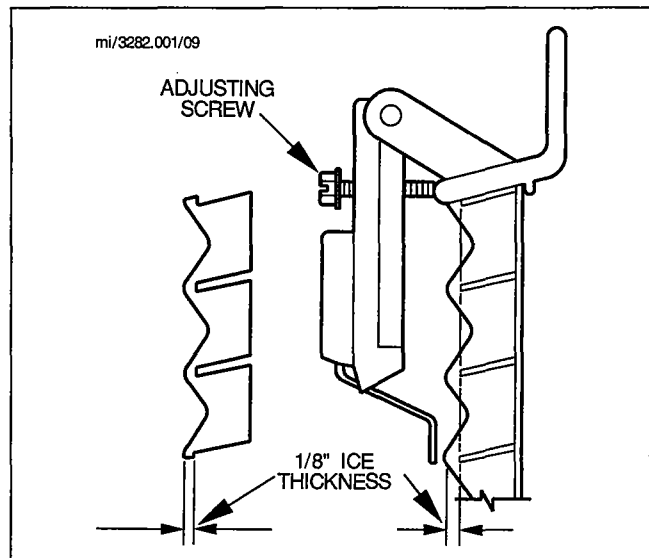

FIGURE 9. ICE THICKNESS CHECK

#### NOTE

Don't turn the adjusting screw more than 1/4 turn at a time. If necessary, check the bridge for two harvest cycles after initial adjustment before adjusting again.

2. Ensure ice thickness probe wires and bracket do not restrict movement of the probe.

# SECTION 3 MAINTENANCE

Follow a general maintenance schedule to ensure reliable, trouble-free operation as well as maximum ice production.

You are responsible to maintain the ice machine in accordance with this manual. Call your local qualified Manitowoc Service Representative to perform the maintenance if at any time you are unsure or unaware of the procedures and safety precautions that must be followed.

We recommend you follow these guidelines on a semi-annual basis\*, depending on ambient air and water conditions and usage. Some components require less frequent maintenance (on an annual basis\*\*).

Record your maintenance dates in the spaces provided for future reference.

## MAINTENANCE GUIDELINES

<b>*SEMI-ANNUAL MAINTENANCE</b>	<b>Page Reference</b>	<b>Dates of Maintenance</b>
1. General ice machine inspection.	8	
2. Exterior cleaning.	8	
3. Cleaning the condenser.	8	
4. Interior cleaning:		
Removal of parts	9	
Cleaning procedures	11	
5. Sanitizing.	12	
6. Manitowoc Tri-Liminator water filter system (if used).	14	
7. Operational checks:		
Water level	5	
Water curtain	5	
Bin switch	6	
Ice thickness	6	
<b>**ANNUAL MAINTENANCE</b>	<b>Page Reference</b>	<b>Dates of Maintenance</b>
9. Water dump valve cleaning.	13	
10. Water-cooled condenser/regulating valve cleaning.	9	

## GENERAL ICE MACHINE INSPECTION

You can eliminate potential service calls by performing routine maintenance. Check all water fittings and lines for leaks and ensure refrigeration tubing is not rubbing or vibrating against other tubing, panels, components, etc. **Remember good preventive maintenance leads to minimal problems and maximum ice production.**

Do not stack anything (boxes, etc.) on or around the ice machine. Ensure remote condenser is well ventilated (if applicable). Do not cover the ice machine while it is operating. It is absolutely necessary to maintain adequate air flow through and around the ice machine to ensure long component life and maximum ice production.

## EXTERIOR CLEANING

1. Clean the area around the ice machine as frequently as necessary to maintain cleanliness and efficient operation.
2. Sponge dust and dirt off the outside of the ice machine with clean, warm water and wipe dry with a soft clean cloth.

### CAUTION

If the panels are stainless steel, clean light stains with soap, detergent, or a commercial cleaner. Do not use cleansers containing bleaching agents as most of these contain chlorine which will stain. Use stainless steel wool to remove heavy stains. Never use plain steel wool as it will cause rusting. After cleaning, rinse thoroughly.

## CLEANING THE CONDENSER

### WARNING

Disconnect electric power to ice machine and remote condenser at the electric service switch box, *before* cleaning condenser!

### Air-Cooled Condenser (Self-Contained and Remote Models)

A dirty condenser restricts airflow resulting in excessively high operating temperatures which in turn reduces ice production and shortens component parts life. Clean the condenser at least every six months.

### CAUTION

Condenser fins are sharp enough to cut your fingers. Use care when cleaning them.

### CAUTION

Cover condenser fan motor to prevent water damage if cleaning condenser and fan with water. Remove cover when cleaning is completed.

1. Remove top and left side panels (self-contained models only).

### NOTE

On remote condensers, remove top cover.

2. Clean outside of condenser (bottom side of remote condenser) with soft brush or vacuum with brush attachment. Brush or wash condenser from top to bottom — not from side to side. Take care not to bend the fins. Shine flashlight through condenser to check for dirt between the fins.

If further cleaning is required, use one or both of the following procedures:

- a. Blow through condenser from the inside out using compressed air. Take care not to bend fan blades. Shine flashlight through condenser to ensure all dirt is removed.
  - b. Clean with a commercial condenser coil cleaner according to the directions and cautions supplied with the cleaner. Thoroughly rinse condenser with clean water.
3. Straighten any bent condenser fins with a fin comb, Figure 10.

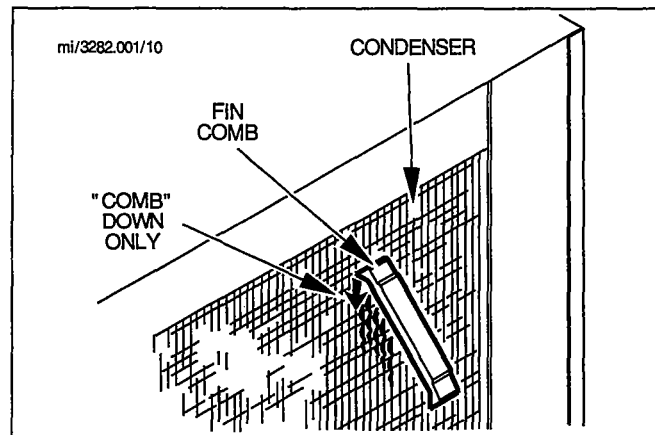

FIGURE 10. STRAIGHTEN BENT CONDENSER FINS

4. Carefully wipe off fan blades and fan motor with a soft cloth, taking care not to bend fan blades. Wash excessively dirty fan blades with warm soapy water, then rinse thoroughly.

## Water-Cooled Condenser (and Water Regulating Valve)

### IMPORTANT

Water-cooled condensers and water regulating valves should be cleaned by qualified maintenance personnel.

The water-cooled condenser and water regulating valve may require cleaning due to scale build-up.

Symptoms of restrictions in the condenser water circuit may include low ice production, and high operating temperatures and pressures.

## INTERIOR CLEANING

For efficient operation, clean and sanitize ice machine every six months.

### IMPORTANT

Do not use hot water. If ice machine requires cleaning and sanitizing more frequently, consult a qualified service company to test the water quality and recommend appropriate water treatment.

Before cleaning, check water dump valve for proper operation (see Cleaning Water Dump Valve, page 14). Deposits may accumulate in the valve causing leakage or restriction of water flow.

### Removal of Parts for Cleaning

1. Loosen two screws holding front panel in place and remove front panel.
2. Set ICE/OFF/WATER PUMP switch at OFF after ice falls from evaporator at completion of Harvest cycle, or set switch at off and allow ice to melt off evaporator.

### CAUTION

Never use any type of object to force ice from evaporator as damage may result.

3. Turn off water to the ice machine at water service valve.

### WARNING

Disconnect electric power to ice machine at the electric switch box before proceeding.

4. Stacked ice machines:
  - a. Remove top panel.
  - b. Lift ice chute up and out of ice machine.
5. Remove all ice from bin.
6. Remove water curtain.
7. Remove drain plug from water trough and allow water to drain into bin.

### Remove Water Pump (Figure 11)

1. Disconnect water pump power cord.

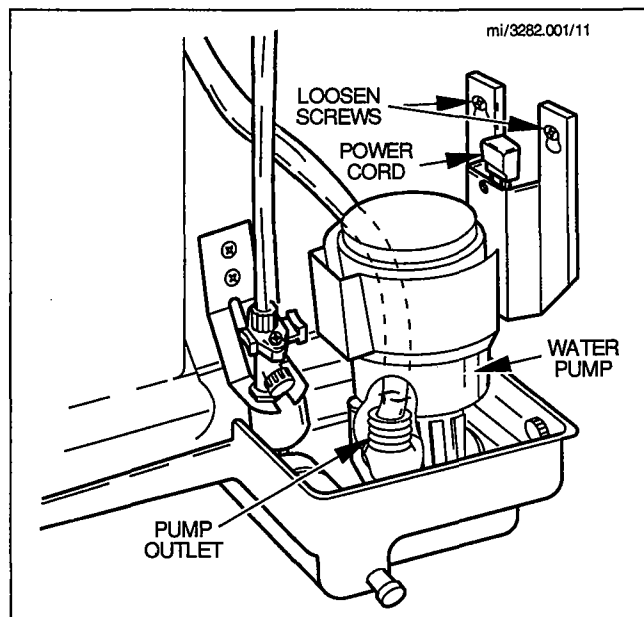

FIGURE 11. WATER PUMP REMOVAL  
(G200 MODELS SHOWN)

2. Disconnect hose or tee from pump outlet.
3. Loosen two screws holding pump mounting bracket to bulkhead.
4. Lift pump and bracket assembly off screws.

### Remove Float Valve (Figure 12)

1. Turn valve splash shield clockwise a full turn or two, then pull the valve forward off the mounting bracket.
2. Disconnect the water inlet tube from the float valve at the compression fitting.
3. Remove filter screen and cap.

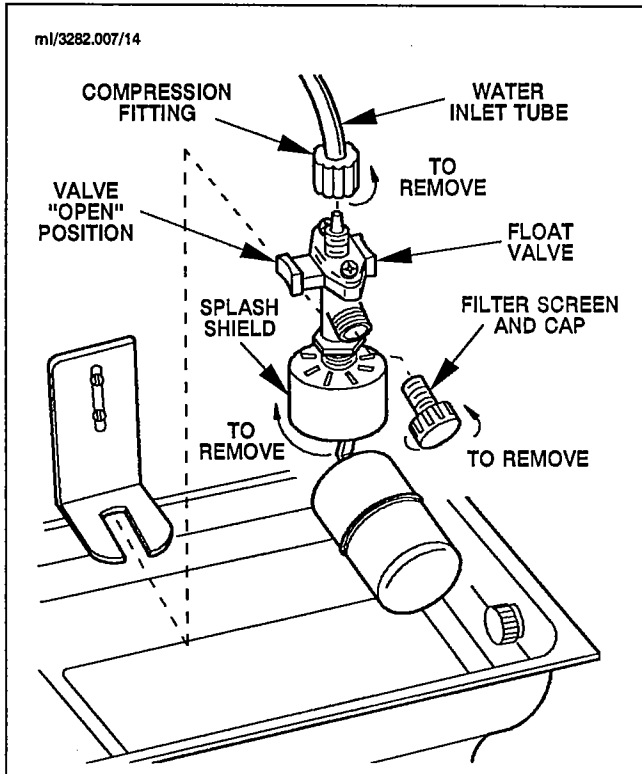

FIGURE 12. FLOAT VALVE REMOVAL

### Remove Distribution Tube (Figure 13)

1. Remove distribution tube from the two spring clips holding it in place.
2. Disconnect the hose from the distribution tube and from the "T."

#### NOTE

To reinstall distribution tube, align locating pin on top extrusion with hole in distribution tube.

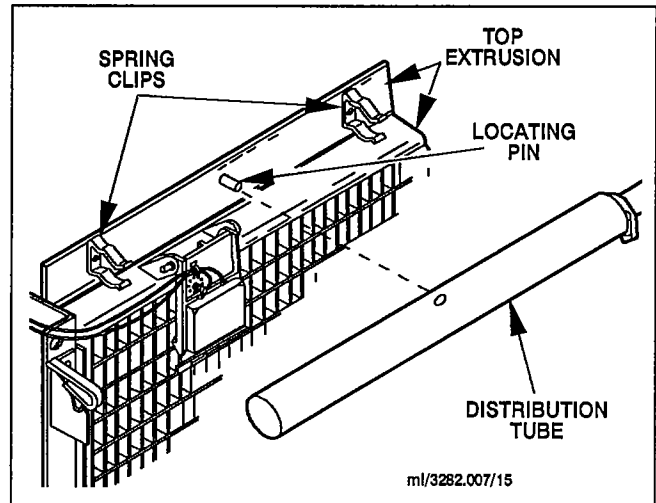

FIGURE 13. DISTRIBUTION TUBE REMOVAL

### Disassemble Distribution Tube (Figure 14)

#### NOTE

Disassembly of the distribution tube is not usually necessary as normal cleaning of the ice machine will clean the tube. The distribution tube should only be disassembled if, after normal cleaning procedures, there is inadequate water flow from the distribution tube. (Ensure that any other water problems are eliminated beforehand.)

1. Heat rubber end plugs on distribution tube in warm water to soften them.
2. Remove end plugs and inner distribution tube.
3. Reheat rubber plugs in warm water after cleaning is complete and reassemble distribution tube.

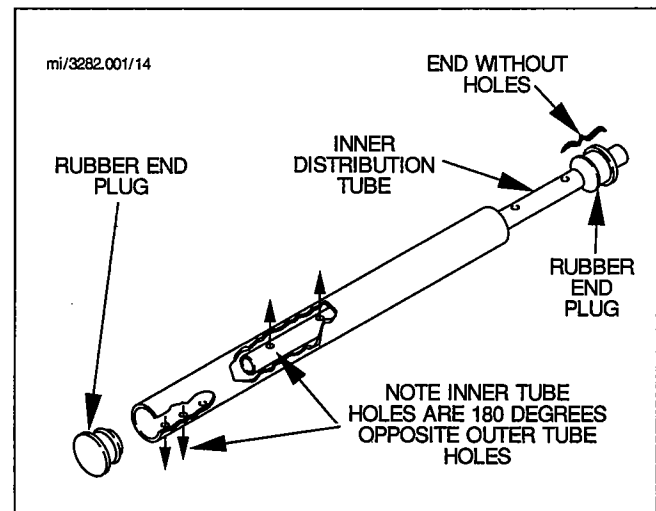

FIGURE 14. DISTRIBUTION TUBE DISASSEMBLY

### NOTE

Position the holes in the inner and outer tubes 180° opposite each other when reassembling. The end of the inner distribution tube without holes must extend from the outer tube when reassembled to allow for attachment of the water line from the pump.

### Remove Ice Thickness Probe (Figure 15)

### WARNING

Disconnect electric power to ice machine at the electric service switch box before proceeding.

1. Disconnect wire leads from inside electrical control box.
2. Compress side of probe at top near hinge pin and disengage it from the bracket.

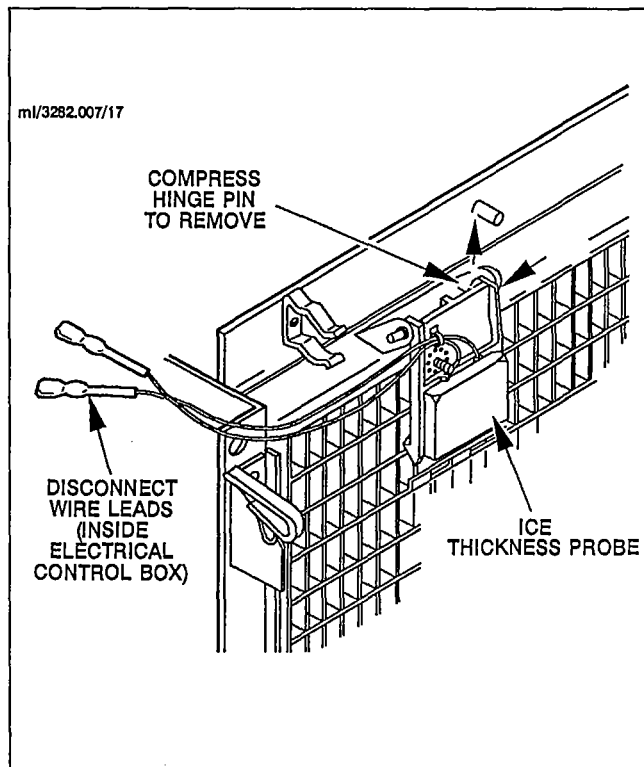

FIGURE 15. ICE THICKNESS PROBE REMOVAL

### Remove Water Trough (Figure 16)

1. Remove thumb screws. Support trough while removing thumb screws.
2. Lower right side of trough into bin while disengaging left side of trough from holding pegs and remove trough from ice machine.

### NOTE

Stacked ice machines: Remove trough from top ice machine by lifting up on front right side of trough, then pull out to disengage trough from pegs on left side of cabinet.

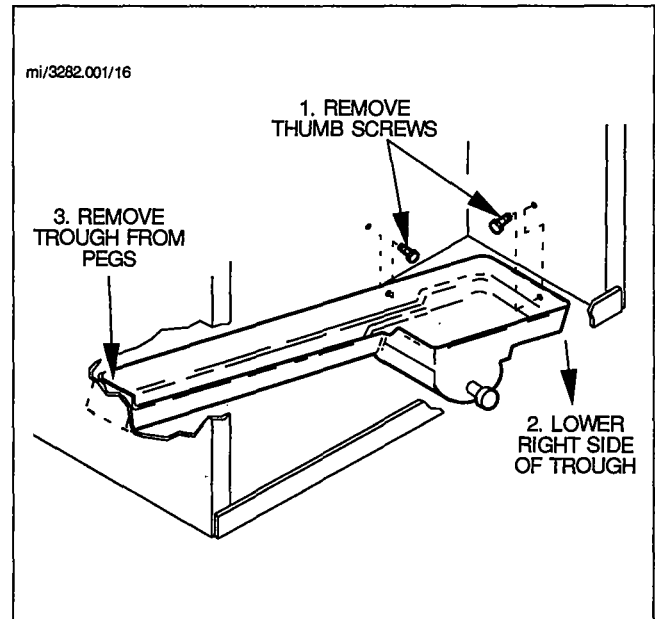

FIGURE 16. WATER TROUGH REMOVAL (G200 MODELS SHOWN)

### Cleaning Procedures

Ice Machine Cleaner is for removal of lime scale or other mineral deposits. It is not used for removal of algae or slime. Refer to Sanitizing for removal of algae and slime.

### CAUTION

Use only Manitowoc Ice Machine Cleaner, Part No. 94-0546-3, in recommended concentration as this is compatible with materials used in the manufacture of Manitowoc Ice Machines.

1. Soak parts in a solution of no more than 16 ounces of cleaner to one gallon of warm water. Use a brush (**DO NOT USE A WIRE BRUSH**) or a sponge to clean the parts, taking care not to damage them.

### CAUTION

Do not immerse the water pump motor in the cleaning solution. Also, use care when cleaning the ice bridge thickness probe so as not to move the adjusting screw.

2. Use the cleaning solution and a brush or sponge to remove scale build-up from the top, sides and bottom extrusions, the inside of the ice machine panels, and the entire inside of the ice bin.

A dirty top extrusion, Figure 13, could result in uneven water flow over the evaporator. Ensure all scale and dirt are removed.

3. Thoroughly rinse with clean water all parts and surfaces washed with the cleaning solution.

#### **NOTE**

Incomplete rinsing of the ice bridge thickness probe could leave residue which could cause the ice machine to go into premature harvest. For best results, brush or wipe off while rinsing and then wipe dry.

4. Reinstall all parts removed for cleaning except front panel and top chute (if stacked).

#### **Clean the Evaporator Surface**

#### **NOTE**

Failure to clean other parts prior to evaporator may result in poor cleaning of the evaporator surface.

1. Turn on water to ice machine at water service valve and ensure float valve is open, Figure 12.
2. Allow trough to fill to proper operating level, Figure 6.
3. Set ICE/OFF/WATER PUMP switch at WATER PUMP.
4. Add two ounces of cleaner to water trough and allow solution to circulate a maximum of 10 minutes.

#### **NOTE**

Use a soft brush on excessively dirty evaporator to help remove deposits. Ensure connecting holes in back corners of cube molds are open.

5. Set ICE/OFF/WATER PUMP switch at OFF.
6. Shut off water at float valve. See Figure 12.
7. Drain water trough by removing drain plug.
8. Thoroughly rinse trough with clean water, then reinstall drain plug.
9. Turn on water at float valve.
10. Set ICE/OFF/WATER PUMP switch at WATER PUMP and allow water trough to fill to proper operating level.

11. Sanitize ice machine after cleaning.
12. Perform Operational Checks, pages 5 and 6.

#### **SANITIZING**

Sanitizer is used for removal of algae or slime, AND AFTER USE OF MANITOWOC ICE MACHINE CLEANER. It is not used for removal of lime scale or other mineral deposits.

1. Loosen two screws holding front panel in place and remove front panel.
2. Set ICE/OFF/WATER PUMP switch at OFF after ice falls from evaporator at completion of Harvest cycle or set switch at OFF and allow ice to melt off evaporator.

#### **CAUTION**

Never use any type of object to force ice from evaporator as damage may result.

3. Stacked ice machines: Remove ice chute as described under Removal of Parts for Cleaning, step 4, page 9.
4. Remove water curtain, Figure 7.
5. Remove all ice from bin.
6. Set ICE/OFF/WATER PUMP switch at WATER PUMP.
7. Add one ounce of sanitizer to water trough and allow solution to circulate a minimum of one minute.
8. Drain solution from trough by removing drain plug, Figure 6.
9. Thoroughly rinse trough with clean water, then reinstall drain plug.
10. Wash all surfaces requiring sanitizing (ice machine and bin) with a solution of one ounce of sanitizer to up to four gallons of water.
11. Thoroughly rinse all sanitized surfaces with clean water.
12. Set ICE/OFF/WATER PUMP switch at ICE.
13. Perform Operational Checks, pages 5 and 6. Discard first batch of ice.

## CHECKING AND CLEANING THE WATER DUMP VALVE

### NOTE

This covers the Alco plastic body water dump valve only.

Although cleaning the dump valve is considered maintenance, we recommend you use qualified maintenance personnel or service company to perform the following procedures.

### Operation Check

1. Remove top and right side panel.
2. Set ICE/OFF/WATER PUMP switch at ICE.
3. Check clear plastic outlet drain hose of dump valve, Figure 17, for leakage while the ice machine is in the freeze mode.
4. If the dump valve is leaking, remove, disassemble and clean.

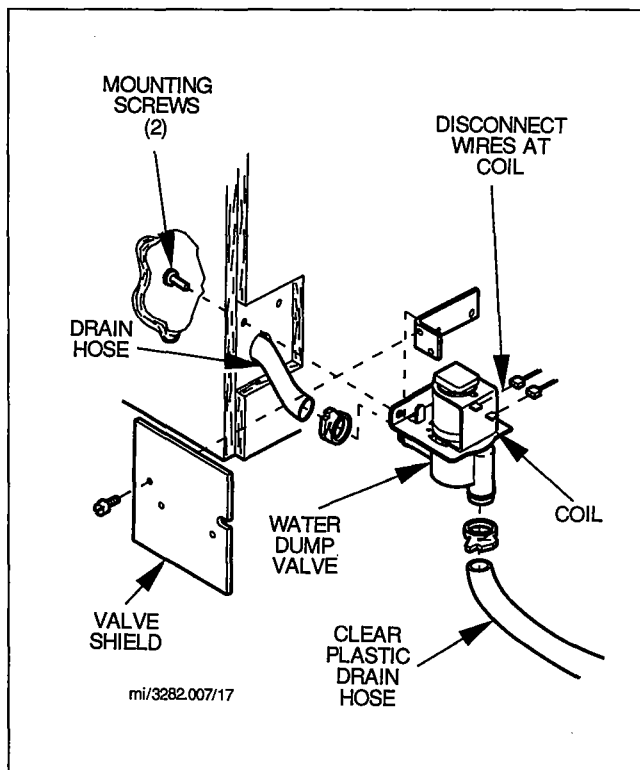

FIGURE 17. WATER DUMP VALVE REMOVAL

## Remove Water Dump Valve (Figure 17)

### WARNING

Disconnect electric power to the ice machine at the electric service switch box.

### NOTE

Water dump valve can be cleaned without removing.

1. Drain water trough by removing drain plug.
2. Remove water dump valve shield from water dump valve mounting bracket.
3. Disconnect wires from dump valve coil.
4. Remove two screws securing dump valve and mounting bracket.
5. Remove tubing from dump valve by twisting off hose clamps.

## Disassemble Water Dump Valve (Figure 18)

1. Lift cap and slide coil retainer cap from top of coil.

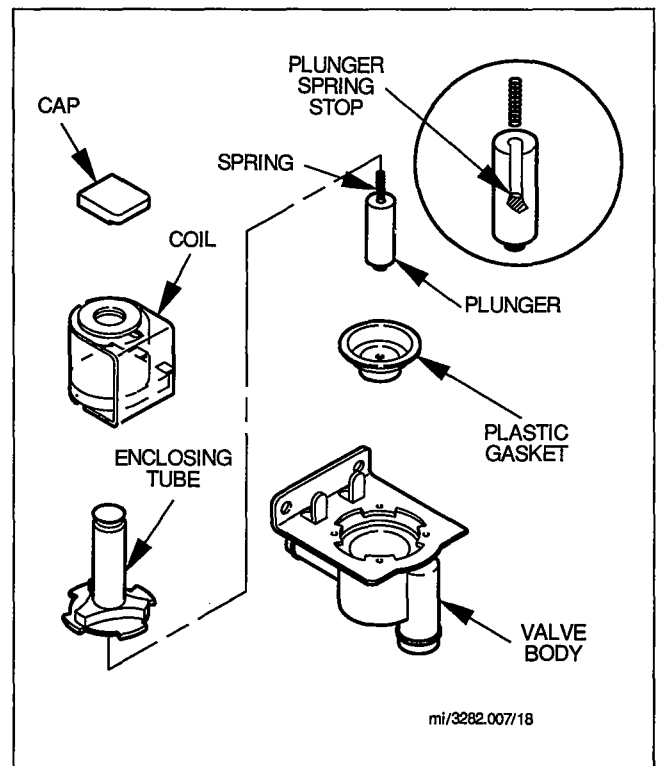

FIGURE 18. WATER DUMP VALVE DISASSEMBLY

2. Lift coil assembly off valve body. Note position of coil assembly on valve before removing. When reassembling valve, ensure coil is in same position.

3. Press down on plastic nut and rotate nuts 1/4 turn and remove nut and enclosing tube from dump valve.
4. Remove enclosing tube, plunger and plastic gasket from valve body.

#### NOTE

It is not necessary to remove spring from plunger when cleaning. If spring is removed, insert *flared* end of spring into slotted opening in top of plunger until spring comes in contact with plunger spring stop. Use care not to stretch or damage spring in plunger when cleaning.

#### Cleaning Water Dump Valve

Replace excessively dirty or worn water dump valve components. Contact your Manitowoc Dealer.

1. Soak components in cleaning solution (refer to Cleaning Procedures, page 11). Remove heavy scale deposits with a stiff-bristle brush. Use a small bottle brush to clean inside the enclosure tube. Wipe off rubber gasket with soft cloth.

#### CAUTION

Do not soak coil assembly.

2. Thoroughly rinse components with clean water.
3. Thoroughly dry plunger and inside of enclosure tube.
4. Reassemble water dump valve and reinstall in ice machine.

## WATER FILTRATION

Manitowoc recommends the use of water filtration on the water supply to the ice machine. Filtration reduces mineral build-up on the ice making surfaces of the ice machine which can slow the ice making process, reduce ice production, increase energy consumption and increase cleaning frequency. Filtration also improves ice quality. If the local water supply has high turbidity (dirty water), a prefilter is also recommended.

Consult your local dealer or distributor for information on Manitowoc's full line of Tri-Liminator filtration systems.

To ensure maximum filtration efficiency, replace the primary filter cartridge every six months. The filter gauge will indicate if replacement is necessary prior to six months usage (below 20 psig).

Tri-Liminator systems which include a prefilter should not require primary filter replacement prior to six months' usage. If replacement is indicated, first replace the prefilter.

#### Replacement Procedure (Figure 19)

1. Turn off water supply using the inlet shut-off valve.
2. Depress pressure release button to relieve pressure.
3. Unscrew housing from cap (see illustration).
4. Remove used cartridge from housing and discard.

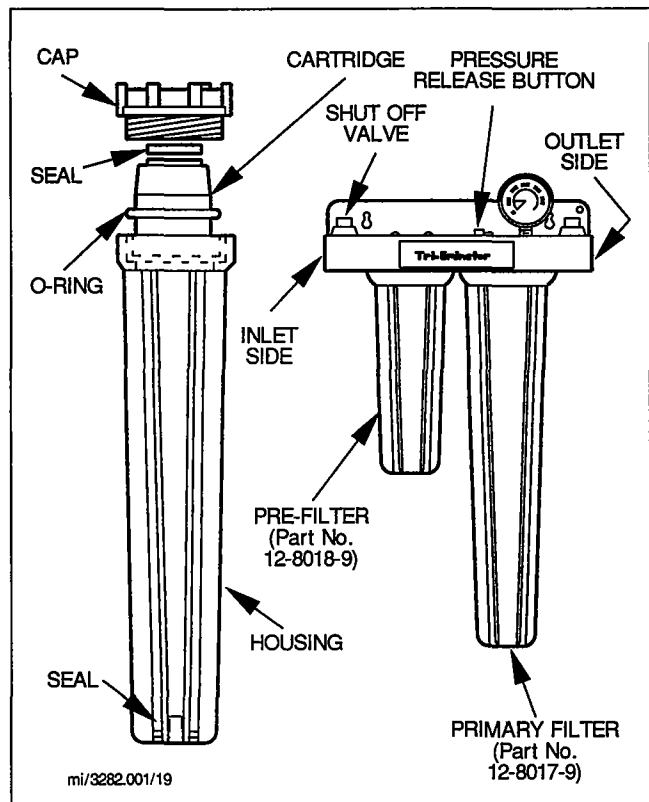

**FIGURE 19. WATER FILTRATION**

5. Remove O-ring from groove in the housing and wipe groove and O-ring clean. Relubricate O-ring with a coating of clean petroleum jelly (Vaseline). Place O-ring back in groove and, with two fingers, press it down into the groove.

#### NOTE

This is important to insure proper filter seal. Make sure the O-ring is seated level in the groove.

6. Insert a new cartridge into the housing making sure that it slips down over the housing standpipe.

7. Screw the housing onto the cap and **hand tighten. Do not over-tighten or use spanner wrench.**
8. Repeat steps 3 through 7 for each filter housing.
9. Turn on the water supply to allow housing (and filter) to slowly fill with water.
10. Depress the pressure release button to release trapped air from housing. Check for leaks.

## REMOVAL FROM SERVICE/WINTERIZATION

You must take special precautions if the ice machine is to be removed from service for extended periods or exposed to ambient temperatures of 32°F or below.

### CAUTION

If water is allowed to remain in the machine in freezing, ambient temperatures, it could freeze, resulting in severe damage to some components. A failure of this nature is not covered by warranty.

### Self-Contained Air-Cooled Machines

1. Disconnect electric power at circuit breaker or electric service switch.
2. Turn off water going to ice machine.
3. Remove drain plug from water trough.
4. Disconnect drain line and incoming ice making water line at rear of ice machine.
5. Blow compressed air in both incoming water opening and drain opening in rear of machine until water is no longer coming out of float valve and drain.
6. Ensure that no water is trapped in any of the machine's water lines, drain lines, distribution tubes, etc.
7. If machine is outside, cover machine to prevent exposure to the elements.

### Water-Cooled Machines

1. Perform all procedures listed under "Self-Contained Air-Cooled Machines."
2. Disconnect incoming water line and drain line from water-cooled condenser.

3. Pry open water regulating valve by inserting large standard screwdriver between bottom spring coils of valve. Pry spring upward to open valve, Figure 20.
4. Hold valve open and blow compressed air through condenser until no water remains.

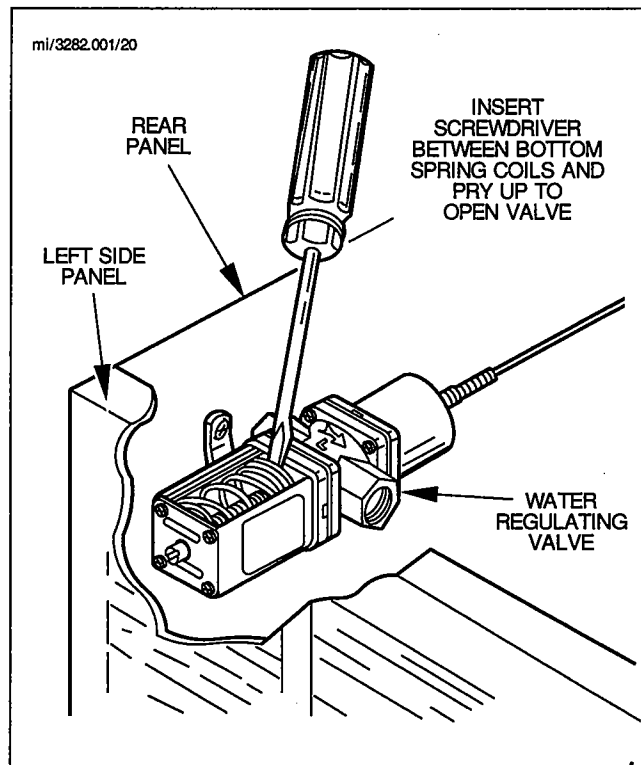

**FIGURE 20. MANUALLY OPEN WATER REGULATING VALVE**

### Remote Machines

1. Frontseat receiver service valve, then pump down ice machine. (Hang a tag on toggle switch as a reminder to open receiver service valve on start-up.)
2. Perform all procedures listed under "Self-Contained Air-Cooled Machines."

### NOTE

Before putting a remote machine back into operation after winterization, backseat the receiver service valve.

## SECTION 4 BEFORE CALLING FOR SERVICE

If a problem arises during the operation of your ice machine, follow the checklist below before calling for service.

### CHECKLIST

Problem	Possible Cause	To Correct
Ice machine does not operate.	<p>No electrical power to ice machine.</p> <p>Tripped high pressure cutout.</p> <p>ICE/OFF/WATER PUMP switch set improperly.</p> <p>Water curtain stuck open.</p> <p>Remote receiver valve closed.</p> <p>Bin switch activating pin out of adjustment.</p>	<p>Replace fuse, reset circuit breaker, turn on main switch.</p> <p>Reset high pressure cutout, Figure 2, page 3.</p> <p>Set switch at ICE.</p> <p>Water curtain must swing freely, Figure 7, page 5.</p> <p>Open valve.</p> <p>Adjust bin switch activating pin, Figure 8, page 6.</p>
Ice machine does not release ice or is slow to harvest.	<p>Ice machine dirty.</p> <p>Ice machine not level.</p> <p>Air-cooled models: low ambient.</p> <p>Water regulating valve leaking during harvest mode (water-cooled ice machines).</p>	<p>Clean and sanitize ice machine, pages 9 and 12.</p> <p>Level ice machine.</p> <p>Minimum ambient is 35°F.</p> <p>See Water-Cooled Condenser, page 9.</p>
Ice machine does not cycle into harvest mode.	<p>Ice thickness probe dirty.</p> <p>Ice thickness probe wires disconnected.</p> <p>Ice thickness probe out of adjustment.</p> <p>Uneven ice fill (thin at top of evaporator).</p>	<p>Clean and sanitize ice machine, pages 9 and 12.</p> <p>Connect wires.</p> <p>Adjust ice thickness probe, Figure 9, page 6.</p> <p>See Shallow or Incomplete Cubes.</p>
Poor quality ice. (Ice soft or not clear.)	<p>Quality of incoming water.</p> <p>Ice machine dirty.</p> <p>Water dump valve not working.</p> <p>Water softener working improperly (if installed).</p>	<p>Contact qualified service company to test quality of water and make appropriate filter recommendations.</p> <p>Clean and sanitize ice machine, pages 9 and 12.</p> <p>See Checking and Cleaning the Water Dump Valve, page 13.</p> <p>Repair water softener.</p>

Problem	Possible Cause	To Correct
<p>Shallow or incomplete cubes, incomplete ice fill pattern on evaporator.</p>	<p>Ice thickness probe out of adjustment.</p> <p>Water trough level too high or too low.</p> <p>Water float valve filter screen dirty.</p> <p>Ice machine dirty.</p> <p>Water filtration.</p> <p>Hot incoming water piped into ice machine.</p> <p>Incorrect incoming water pressure.</p> <p>Leaky water dump valve.</p> <p>Ice machine not level.</p>	<p>Adjust ice thickness probe, Figure 9, page 6.</p> <p>Adjust float valve, Figure 6, page 5.</p> <p>Clean filter screen, Figure 13, page 10.</p> <p>Clean and sanitize ice machine, pages 9 and 12.</p> <p>Replace filter, Figure 19, page 14.</p> <p>Connect ice machine to cold water supply. See Installation Instructions.</p> <p>Water pressure must be 20-80 psi. See Checking and Cleaning the Water Dump Valve, page 13.</p> <p>Level ice machine.</p>
<p>Low ice capacity.</p>	<p>Water float valve filter screen dirty.</p> <p>Float valve shut-off closed.</p> <p>Incoming water supply shut off.</p> <p>Float valve stuck open.</p> <p>Dirty condenser.</p> <p>High ambient temperature.</p> <p>Inadequate clearance around ice machine causing air flow restriction.</p> <p>Objects stacked on or around ice machine blocking air flow to condenser (air-cooled models).</p> <p>Air baffle not installed (air-cooled models).</p>	<p>Clean filter screen, Figure 12, page 10.</p> <p>Open shut-off valve, Figure 12, page 10.</p> <p>Open water service valve.</p> <p>Clean and adjust, Figure 6, page 5.</p> <p>Clean condenser (air-cooled, page 8, water-cooled, page 19).</p> <p>Maximum ambient is 110°F.</p> <p>Provide adequate clearance.</p> <p>Remove objects.</p> <p>Install air baffle per instructions on air baffle.</p>