

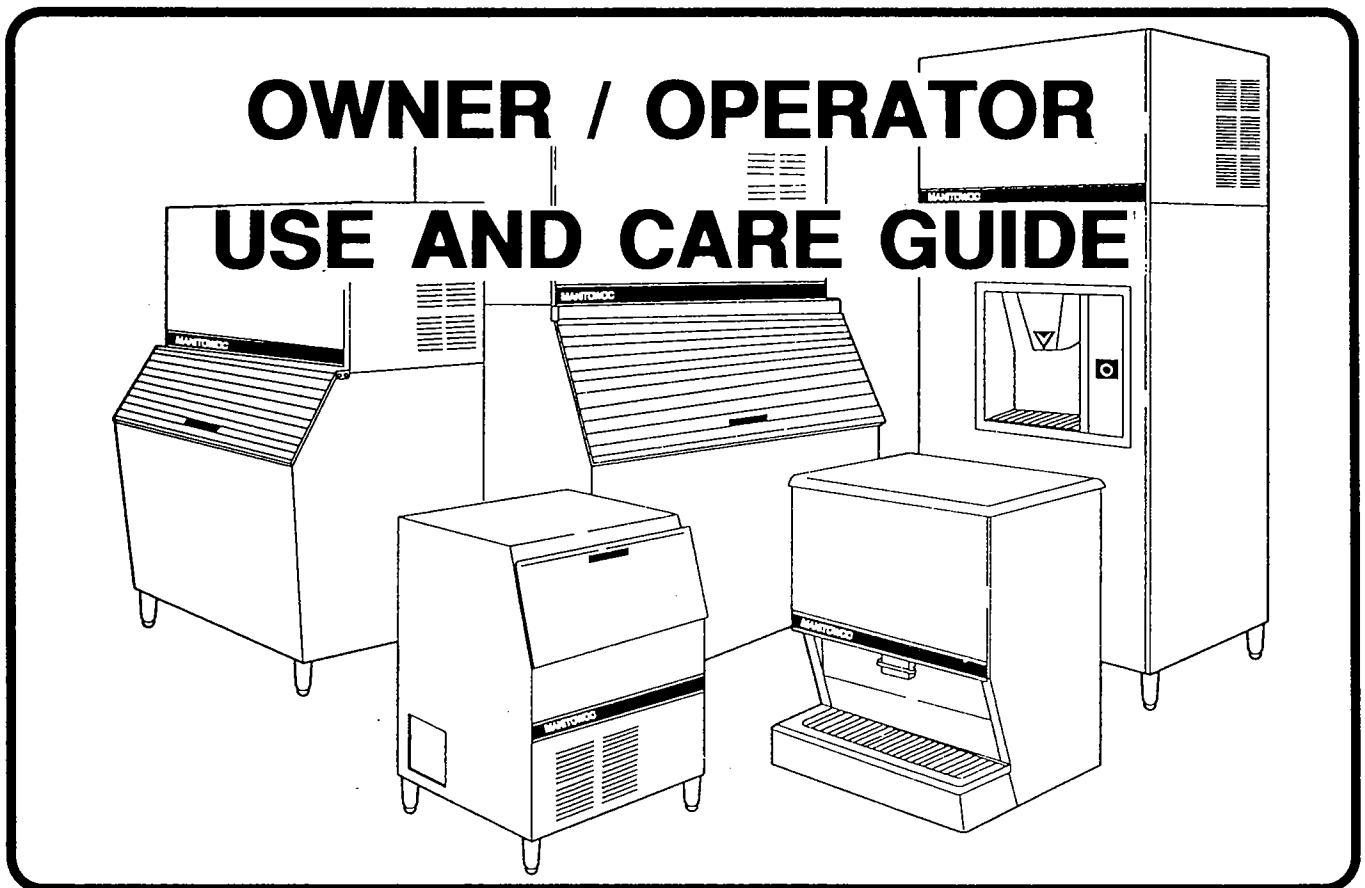

Manitowoc[®]

ICE MACHINES

**Series
G150**



Thank you for selecting a Manitowoc Ice Machine, the dependability leader in ice making equipment and related products. With proper care and maintenance, your new Manitowoc Ice Machine will provide you with many years of reliable and economic performance.

This product qualifies for the following listings:

We reserve the right to make product improvements at any time. Specifications and design are subject to change without notice.



Part No. 80-0857-3

IMPORTANT

Proper care and maintenance are essential for maximum ice production and trouble-free operation of your Manitowoc Ice Machine.

You should read and understand this Use and Care Guide, as it contains valuable care and maintenance information.

If you encounter problems not covered by this guide, please contact your local Manitowoc dealer or distributor for service information.

Your Use and Care Guide covers the following model numbers:

Air Cooled

GR0150A

GD0152A

Water Cooled

GR0151W

GD0153W

TABLE OF CONTENTS

SECTION 1 - GENERAL INFORMATION

Model/Serial Numbers Location	1
Owner Warranty Registration Card	2
About Your Warranty	2

SECTION 2 - ABOUT YOUR ICE MACHINE

Sequence of Operation	3
Freeze Sequence	3
Harvest Sequence	3
Automatic Stop and Start	3
Operational Checks	4
Water Level Check	4
Water Curtain Check	4
Bin Switch Check	5
Ice Thickness Check	5

SECTION 3 - MAINTENANCE

Maintenance Guidelines	6
General Ice Machine Inspection	7
Exterior Cleaning	7
Cleaning the Condenser	7
Air-Cooled Condenser	7
Water-Cooled Condenser	8
Interior Cleaning	8
Removal of Parts for Cleaning	8
Remove Water Pump	8
Remove Float Valve	9
Remove Distribution Tube	9
Disassemble Distribution Tube	9
Remove Ice Thickness Probe	10
Remove Water Trough	10
Cleaning Procedures	10
Cleaning the Evaporator	11
Sanitizing	11
Water Filtration	12
Replacement Procedure	12
Removal from Service/Winterization	13

SECTION 4 - BEFORE CALLING FOR SERVICE

Checklist	14
---------------------	----

MANITOWOC ICE, INC.
2110 South 26th Street, P.O. Box 1720, Manitowoc, WI 54221-1720 U.S.A.
Telephone 920-682-0161
FAX 920-683-7879

SECTION 1 GENERAL INFORMATION

MODEL/SERIAL NUMBERS LOCATION

Record the model number and serial number of your ice machine and bin or dispenser in the space provided below for your convenience. These numbers are required when requesting information from your local Manitowoc distributor, service representative, or Manitowoc Ice, Inc.

The model and serial numbers are listed on the OWNER WARRANTY REGISTRATION CARD, and on the MODEL/SERIAL NUMBERS DECAL affixed to the inside of the ice machine and on the side panel of the bin, Figure 1.

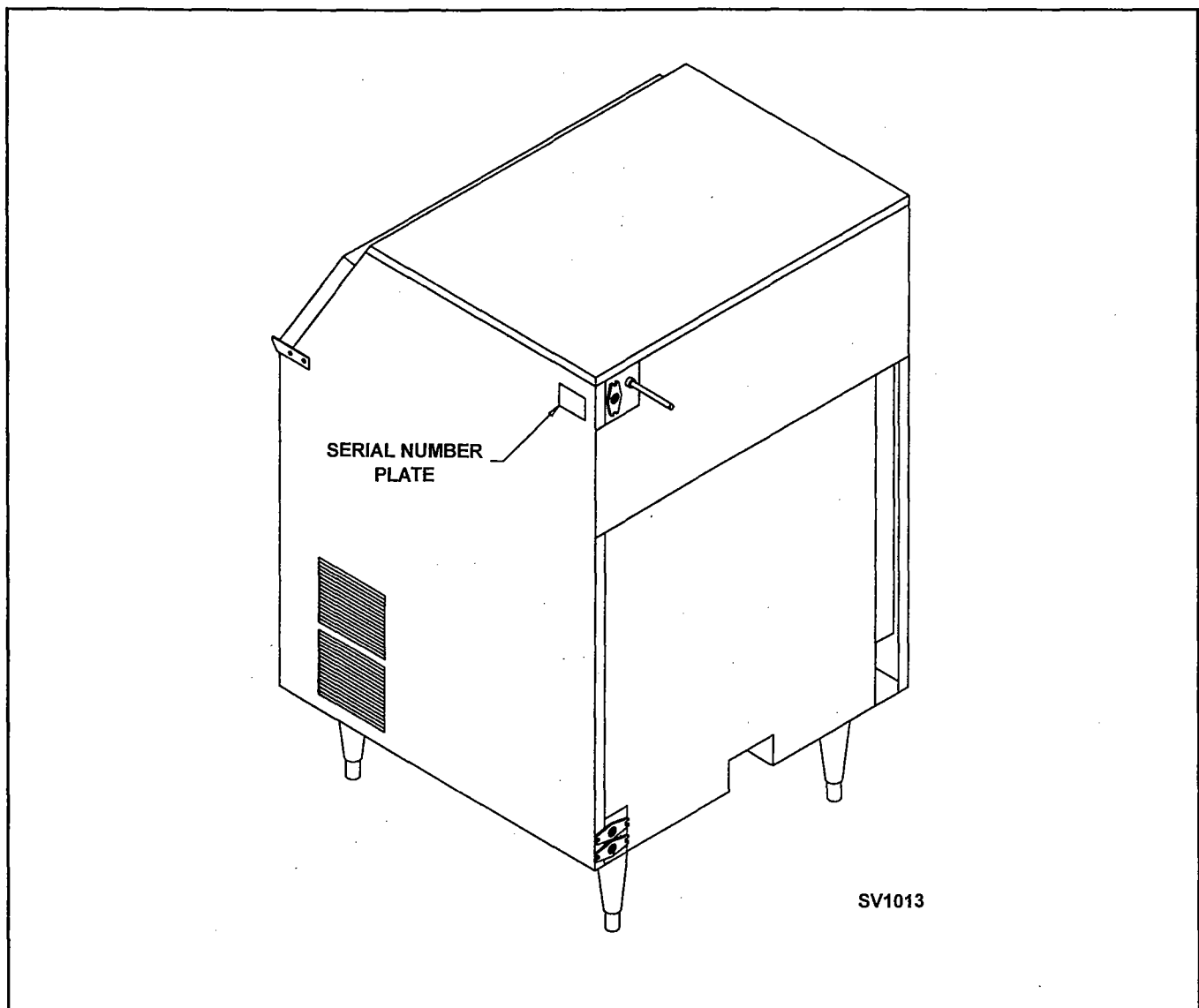

FIGURE 1. MODEL/SERIAL NUMBER LOCATION

MODEL NUMBER _____

SERIAL NUMBER _____

OWNER WARRANTY REGISTRATION CARD

The packet containing this guide also includes your warranty information. Warranty coverage begins the day your new ice machine is installed.

IMPORTANT

To validate the installation date, fill in the OWNER WARRANTY REGISTRATION CARD and mail it as soon as possible.

If your card is not returned, Manitowoc will use the date of sale to the Manitowoc Distributor as the first day of warranty coverage for your new ice machine.

About Your Warranty

For your convenience, the warranty statement is duplicated on the inside back cover of this guide.

Contact your local Manitowoc representative or our Wisconsin headquarters for further warranty information.

WARRANTY COVERAGE

Parts

1. Your ice machine is warranted against defects in materials and workmanship under normal use and service for two (2) years from the date of the original installation. It is important to send in your warranty registration card so Manitowoc can begin your warranty on the installation date.
2. An additional three years (five years total) warranty is provided on the evaporator and the compressor from the date of original installation.

Labor

The labor allowance to repair or replace defective components is for two (2) years from the date of original installation.

Exclusions from Warranty Coverage

The following items are not included in the warranty coverage of your ice machine.

1. Normal maintenance, adjustments and cleaning as outlined in this manual.
2. Repairs due to unauthorized modifications to the ice machine or the use of nonapproved parts without written approval from Manitowoc Ice, Inc.
3. Damage resulting from improper installation as outlined in the Installation Manual, improper electrical supply, water supply or drainage, as well as damage resulting from flood, storms, or other acts of God.
4. Premium labor rates due to holidays, overtime, etc. Travel time, flat rate service call charges, mileage and miscellaneous tools and materials charges not listed on the payment schedule are excluded, as well as additional labor charges resulting from the inaccessibility of the ice machine.
5. Parts or assemblies subjected to misuse, abuse, neglect or accidents.
6. When the ice machine has been installed, cleaned and/or maintained inconsistent with the technical instructions provided in this Owner/Operator Use and Care Guide and the Installation Manual.

Authorized Warranty Service

To comply with the provisions of the warranty, a refrigeration service company – qualified and authorized by your Manitowoc distributor or a Contracted Service Representative – must perform the warranty repair.

NOTE

If the dealer you purchased the ice machine from **IS NOT** authorized to perform warranty service, contact your Manitowoc distributor or our Wisconsin headquarters for the name of the nearest authorized service representative.

Service Calls

Service for your ice machine should be applied if, after the procedures listed in this guide have been implemented, the condition of your ice machine has not improved.

Additional Warranties

A Third Year Extended Parts and Labor warranty is available. Contact your local Manitowoc dealer or distributor for information.

SEQUENCE OF OPERATION

NOTE: Typical G150 cycle not shown.

Freeze Sequence (Figure 3)

When the ICE/OFF/WATER PUMP switch is set to ICE, the compressor, condenser fan (air-cooled models), and water pump start.

The water pump pumps water from the water trough up through the distribution tube to direct an even flow of water down across the front of the evaporator. Water flows into each cube mold, gradually building ice. The water which flows back into the water trough is recirculated. The float valve maintains the proper water level in the water trough.

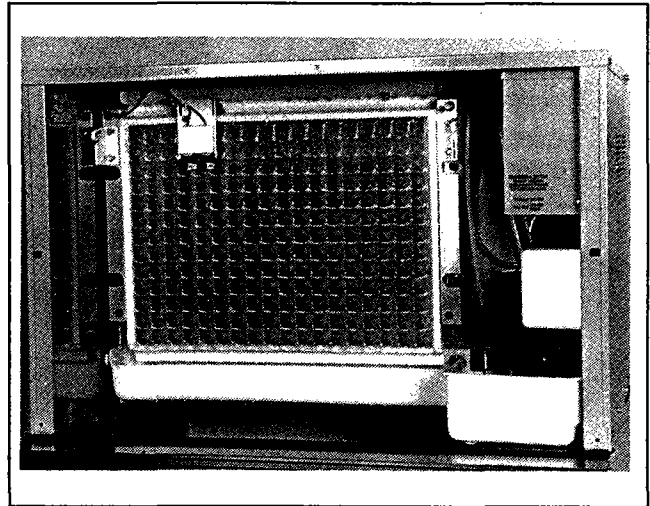

FIGURE 3. FREEZE MODE

Harvest Sequence (Figure 4)

As ice builds in the evaporator to the proper thickness, water flowing over the ice comes in contact with the ice thickness probe. This initiates the HARVEST SEQUENCE. The water pump stops and the hot gas solenoid valve opens diverting hot gas into the evaporator. As the hot gas warms the evaporator, the ice cubes slide as a unit, off the evaporator into the ice storage bin. The falling ice swings the bottom of the water curtain out, activating the bin switch. The bin switch de-energizes the hot gas solenoid valve, returning the ice machine to the FREEZE SEQUENCE.

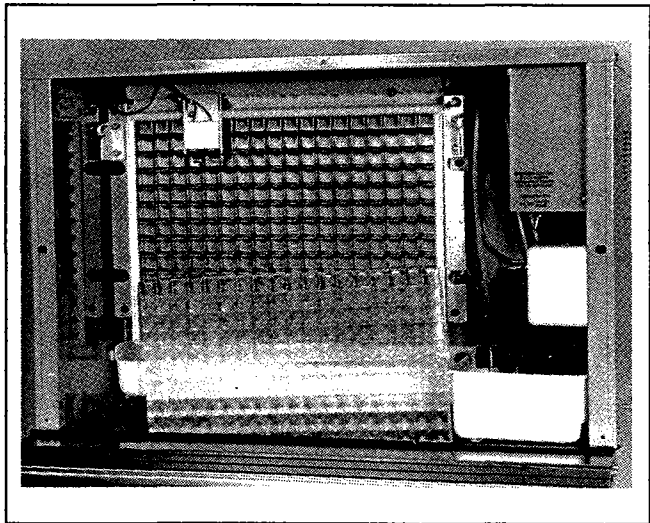

FIGURE 4. HARVEST MODE

Automatic Stop and Start (Figure 5)

When the ice storage bin becomes full, the last harvesting ice cubes do not completely clear the water curtain, holding it open. The bin switch shuts the ice machine off until sufficient ice is removed from the ice storage bin, allowing the ice to clear the water curtain. The return of the water curtain activates the bin switch, putting the machine back into the FREEZE SEQUENCE.

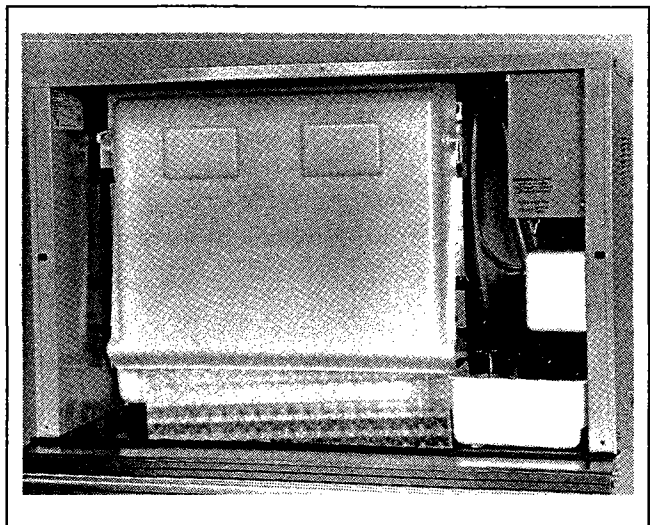

FIGURE 5. AUTOMATIC START/STOP

OPERATIONAL CHECKS

IMPORTANT

Follow the Operational Checks when starting the ice machine after initial installation, prolonged "out of service" periods, and after cleaning and sanitizing to ensure proper operation.

Your Manitowoc ice machine is factory operated and adjusted before shipment. Normally, no adjustments are necessary for new installations. Adjustments and maintenance as outlined in this guide are not covered by warranty. To check and adjust (if necessary), proceed as follows:

Water Level Check

1. Set the ICE/OFF/WATER PUMP switch to OFF.

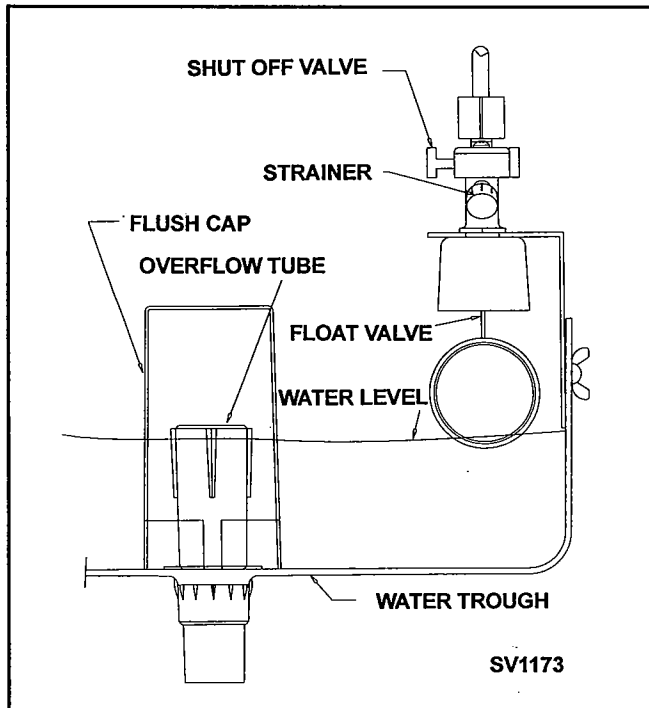

FIGURE 6. WATER LEVEL CHECK

2. Remove the overflow tube from the water trough. Allow water to drain.
3. Reinstall the overflow tube on the water trough and allow it to refill to the proper level of 1-1/4" deep.

The float valve is factory set for the proper water level. If an adjustment is necessary, carefully bend the float arm to achieve the proper level.

Water Curtain Check (Figure 7)

1. Pull the bottom of the water curtain away from the evaporator and release it. The water curtain should fall back to the evaporator.

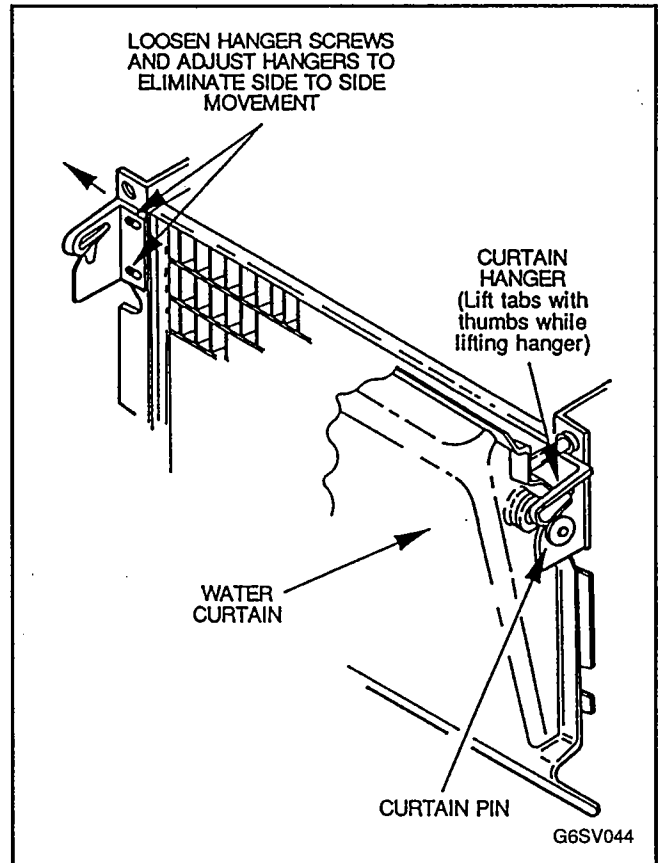

FIGURE 7. WATER CURTAIN CHECK

2. Move the water curtain from side to side. There should be little or no movement.

The water curtain is factory set and should require no adjustment. If an adjustment is necessary, adjust as follows:

- a. Remove the water curtain.
- b. Loosen the curtain hanger screws (two per hanger), and slide the hangers out to prevent any side to side movement.
- c. Retighten the curtain hanger screws.
- d. Reinstall the water curtain.

NOTE

The water curtain pin heads must be positioned under the curtain hanger tabs. The curtain must be centered on the evaporator when it is reinstalled.

Bin Switch Check (Figure 8)

1. Pull the water curtain away from the evaporator until the ice machine shuts off.

NOTE:

The curtain must be held away for approximately 10 seconds before the machine will shut off.

2. Slowly return the water curtain to the evaporator. The ice machine should restart just as the bottom edge of the water curtain passes just inside the edge of the water trough.

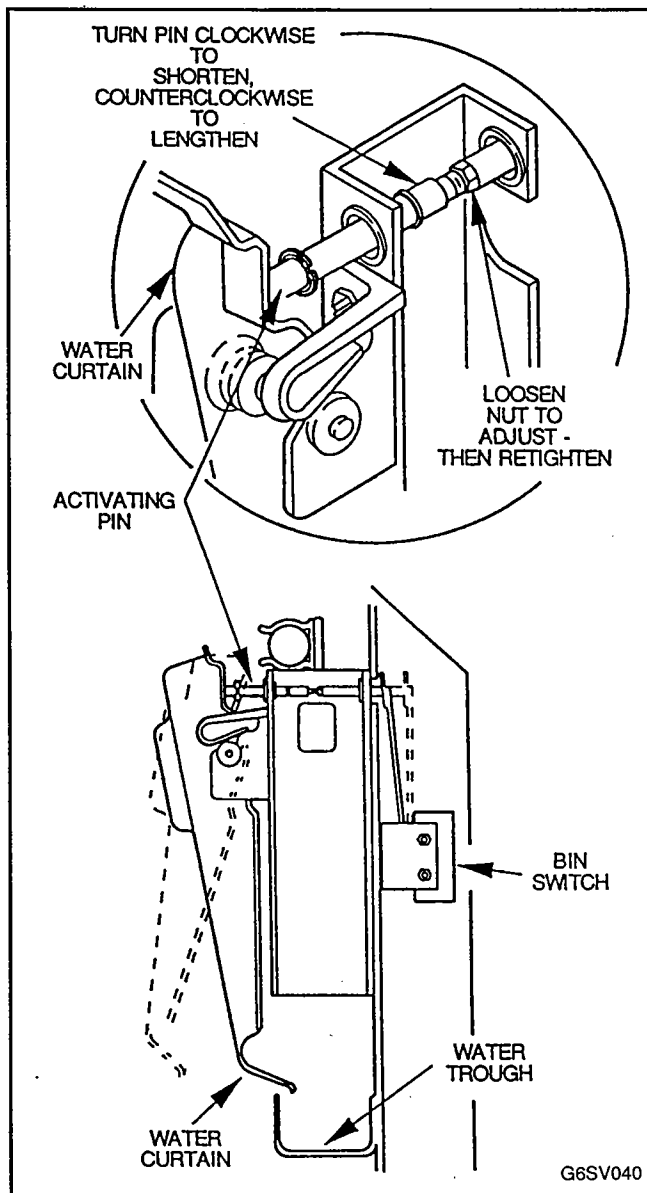

FIGURE 8. BIN SWITCH CHECK

The bin switch is factory set and should not require adjustment. If a bin switch adjustment is necessary, adjust as follows:

- a. Set the ICE/OFF/WATER PUMP switch to OFF.
- b. Slowly pull the bottom of the water curtain away from the evaporator until the bin switch clicks, then slowly return the water curtain toward the evaporator.
- c. If the bin switch clicks before the water curtain reaches the water trough, lengthen the bin switch activating pin.
- d. If the bin switch clicks too far into the evaporator, shorten the bin switch activating pin.
- e. Set the ICE/OFF/WATER PUMP switch to ICE after the adjustment is complete.

Ice Thickness Check (Figure 9)

Be sure the water curtain is in place to prevent any water from splashing out of the water trough.

Inspect the ice bridge connecting the cubes. The ice bridge should be approximately 1/8" thick.

The ice thickness probe is factory set to maintain 1/8" ice bridge thickness. If an adjustment is necessary, adjust as follows:

1. Turn the adjustment screw on the ice thickness probe clockwise to increase thickness, counter-clockwise to decrease thickness.

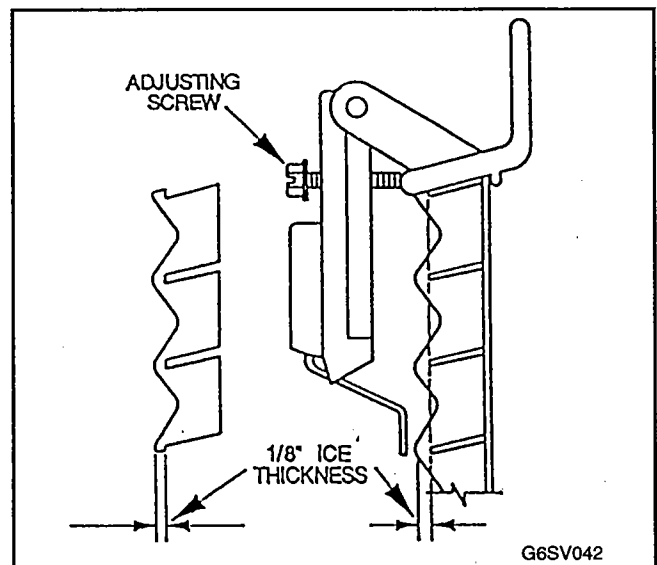

FIGURE 9. ICE THICKNESS CHECK

NOTE

Don't turn the adjusting screw more than 1/4 turn at a time. If necessary, check the ice bridge for two harvest cycles after the initial adjustment before adjusting it again.

2. Ensure the ice thickness probe wires and bracket do not restrict the movement of the probe.

SECTION 3 MAINTENANCE

Follow a general maintenance schedule to ensure reliable, trouble-free operation, as well as maximum ice production.

You are responsible to maintain the ice machine in accordance with this manual. Call your local qualified Manitowoc Service Representative to perform the maintenance if at any time you are unsure or unaware of the procedures and safety precautions that must be followed.

We recommend you follow these guidelines on a semi-annual basis*, depending on ambient air and water conditions and usage. Some components require less frequent maintenance (on an annual basis**).

Record your maintenance dates in the spaces provided for future reference.

MAINTENANCE GUIDELINES

*SEMI-ANNUAL MAINTENANCE	Page Reference	Dates of Maintenance
1. General ice machine inspection.	7	
2. Exterior cleaning.	7	
3. Cleaning the condenser.	7	
4. Interior cleaning: Removal of parts Cleaning procedures	8 10	
5. Sanitizing.	11	
6. Manitowoc Tri-Liminator water filter system (if used).	12	
7. Operational checks: Water level Water curtain Bin switch Ice thickness	4 4 5 5	
**ANNUAL MAINTENANCE		
8. Water-cooled condenser/regulating valve cleaning.	8	

GENERAL ICE MACHINE INSPECTION

You can eliminate potential service calls by performing routine maintenance. Check all water fittings and lines for leaks. Ensure refrigeration tubing is not rubbing or vibrating against other tubing, panels, components, etc. **Remember: good preventive maintenance leads to minimal problems and maximum ice production.**

Do not stack anything (boxes, etc.) on or around the ice machine. Do not cover the ice machine while it is operating. It is absolutely necessary to maintain adequate air flow through and around the ice machine. This ensures long component life and maximum ice production.

EXTERIOR CLEANING

1. Clean the area around the ice machine as frequently as necessary to maintain cleanliness and efficient operation.
2. Sponge dust and dirt off the outside of the ice machine with clean, warm water and wipe it dry with a soft clean cloth.

CAUTION

If the panels are stainless steel, clean light stains with soap, detergent, or a commercial cleaner. Do not use cleaners containing bleaching agents. Most of these contain chlorine, which will stain. Use stainless steel wool to remove heavy stains. Never use plain steel wool as it will cause rusting. After cleaning, rinse thoroughly.

CLEANING THE CONDENSER

WARNING

Disconnect electric power to the ice machine **BEFORE** cleaning the condenser!

Air-Cooled Condenser

A dirty condenser restricts airflow. This causes excessively high operating temperatures, which reduces ice production and shortens component life. Clean the condenser at least every six months.

CAUTION

Condenser fins are sharp enough to cut your fingers. Use care when cleaning them.

CAUTION

Cover the condenser fan motor to prevent water damage if you are cleaning the condenser and the fan with water. Remove the cover when the cleaning is completed.

1. Remove the front panel.
2. Clean the outside of the condenser with a soft brush or a vacuum with a brush attachment. Brush or wash the condenser from top to bottom – not from side to side. Take care not to bend the fins. Shine a flashlight through the condenser to check for dirt between the fins.
If further cleaning is required, use one or both of the following procedures:
 - a. Blow through the condenser from the inside out using compressed air. Take care not to bend the fan blades. Shine a flashlight through the condenser to ensure all the dirt is removed.
 - b. Clean with a commercial condenser coil cleaner, according to the directions and cautions supplied with the cleaner. Thoroughly rinse the condenser with clean water.
3. Straighten any bent condenser fins with a fin comb, Figure 10.

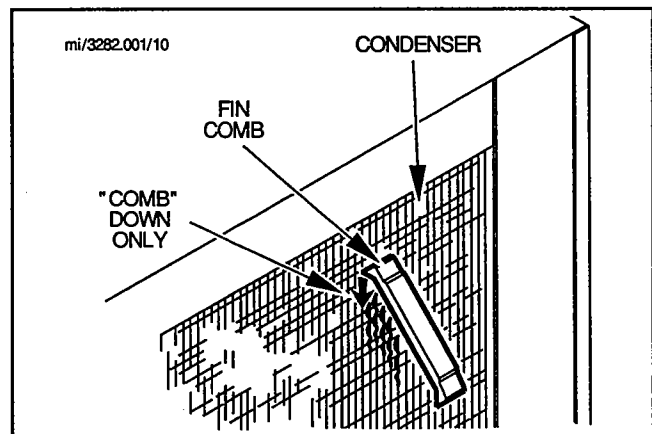

FIGURE 10. STRAIGHTEN BENT CONDENSER FINS

4. Carefully wipe off the fan blades and the fan motor with a soft cloth, taking care not to bend the fan blades. Wash any excessively dirty fan blades with warm soapy water, and rinse thoroughly.

Water-Cooled Condenser (and Water Regulating Valve)

IMPORTANT

Water-cooled condensers and water regulating valves should be cleaned by qualified maintenance personnel.

The water-cooled condenser and the water regulating valve may require cleaning due to scale build-up.

Symptoms of restrictions in the condenser water circuit may include low ice production and high operating temperatures and pressures.

INTERIOR CLEANING

For efficient operation, clean and sanitize the ice machine every six months.

IMPORTANT

Do not use hot water. If the ice machine requires cleaning and sanitizing more frequently, consult a qualified service company to test the water quality and recommend appropriate water treatment.

Removal of Parts for Cleaning

1. Loosen the screws holding the top cover in place and remove.
2. Set the ICE/OFF/WATER PUMP switch to OFF after the ice falls from the evaporator at the completion of Harvest cycle, or set the switch to OFF and allow the ice to melt off the evaporator.

CAUTION

Never use any type of object to force ice from the evaporator. Damage may result.

3. Turn off the water to the ice machine at the water service valve.

WARNING

Disconnect the electric power to the ice machine before proceeding.

4. Remove all ice from the bin.
5. Remove the water curtain.
6. Remove the overflow tube from the water trough and allow the water to drain into bin.

Remove Water Pump (Figure 11)

1. Disconnect the water pump power cord.

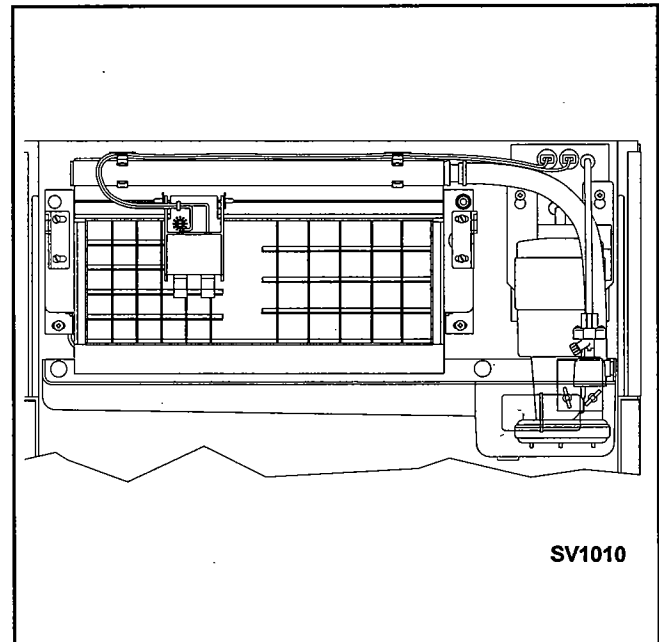

FIGURE 11. WATER PUMP REMOVAL

2. Disconnect the hose from the pump outlet.
3. Loosen the two screws holding the pump mounting bracket to the bulkhead.
4. Lift the pump and bracket assembly off the screws.

Remove Float Valve (Figure 12)

1. Turn the valve splash shield clockwise a full turn or two, then pull the valve off the mounting bracket.
2. Disconnect the water inlet tube from the float valve at the compression fitting.
3. Remove the filter screen and the cap.

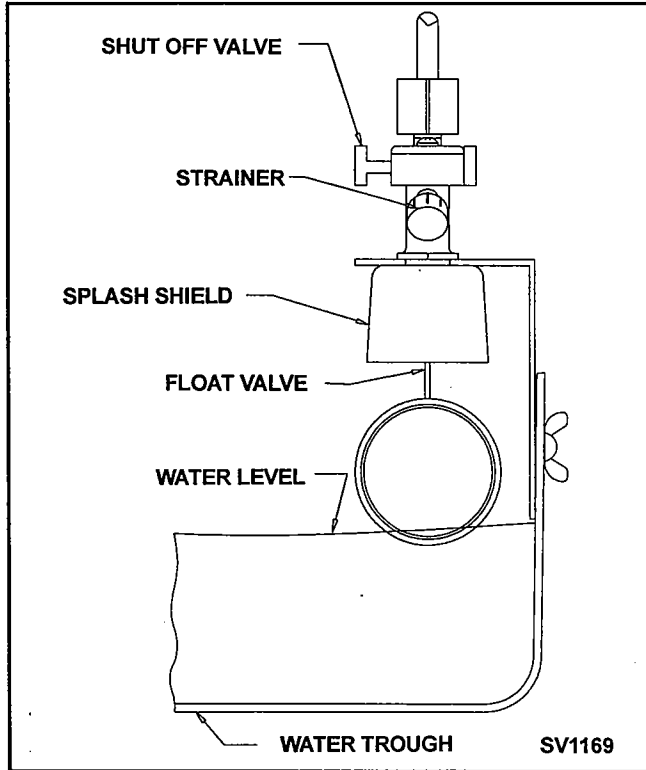

FIGURE 12. FLOAT VALVE REMOVAL

Remove Distribution Tube (Figure 13)

1. Remove the distribution tube from the two spring clips holding it in place.
2. Disconnect the hose from the distribution tube and from the "T."

NOTE

To reinstall the distribution tube, align the locating pin on the top protrusion with the hole in the distribution tube.

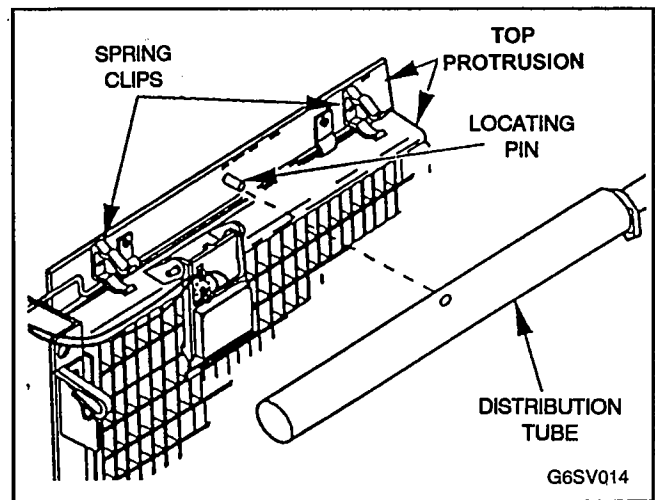

FIGURE 13. DISTRIBUTION TUBE REMOVAL

Disassemble Distribution Tube (Figure 14)

NOTE

Disassembly of the distribution tube is not usually necessary, as normal cleaning of the ice machine will clean the tube. The distribution tube should only be disassembled if, after normal cleaning procedures, there is inadequate water flow from the distribution tube. (Ensure that any other water problems are eliminated beforehand.)

1. Heat the rubber end plugs on the distribution tube in warm water to soften them.
2. Remove the end plugs and the inner distribution tube.
3. Reheat the rubber plugs in warm water after the cleaning is complete, and reassemble distribution tube.

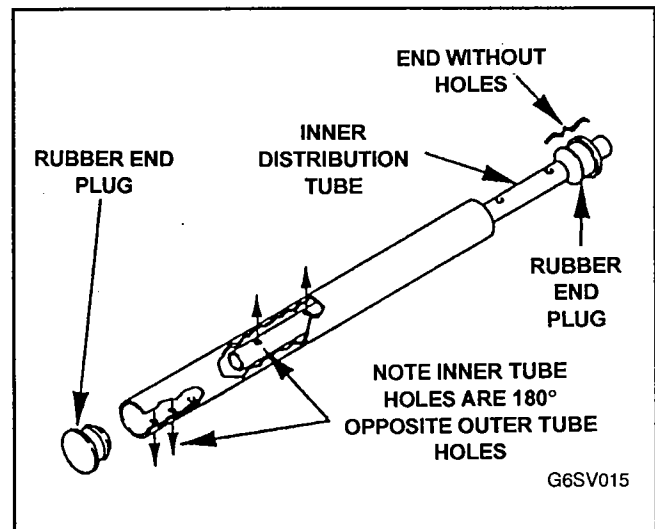

FIGURE 14. DISTRIBUTION TUBE DISASSEMBLY

NOTE

Position the holes in the inner and outer tubes 180° opposite each other when reassembling. The end of the inner distribution tube without holes must extend from the outer tube when reassembled. This allows for attachment of the water line from the pump.

Remove Ice Thickness Probe (Figure 15)

WARNING

Disconnect the electric power to the ice machine before proceeding.

1. Disconnect the wire leads from the back bulkhead.
2. Compress the side of the probe at the top, near the hinge pin. Disengage it from the bracket.

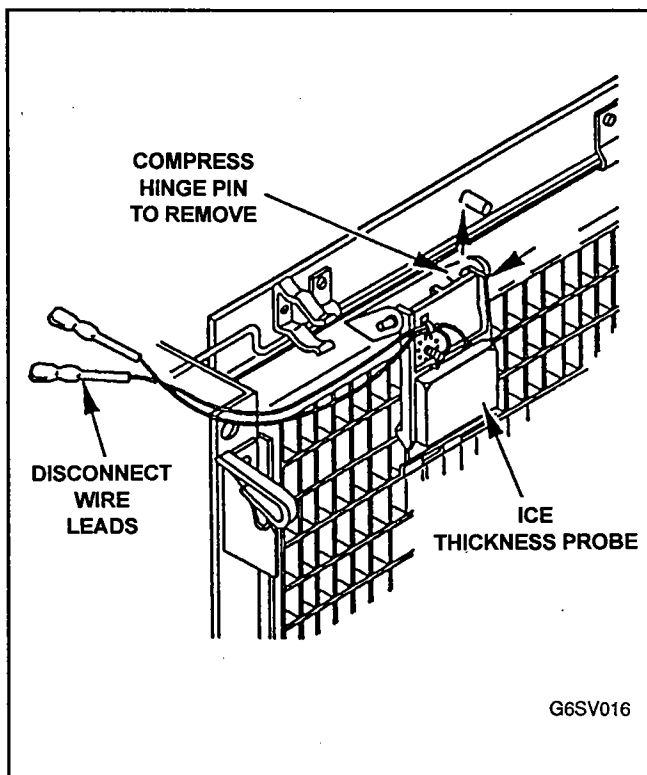

FIGURE 15. ICE THICKNESS PROBE REMOVAL

Remove Water Trough (Figure 16)

1. Remove the thumb screws. Support the trough while removing the thumb screws.
2. Lower the right side of the trough into the bin and remove the trough from the ice machine.

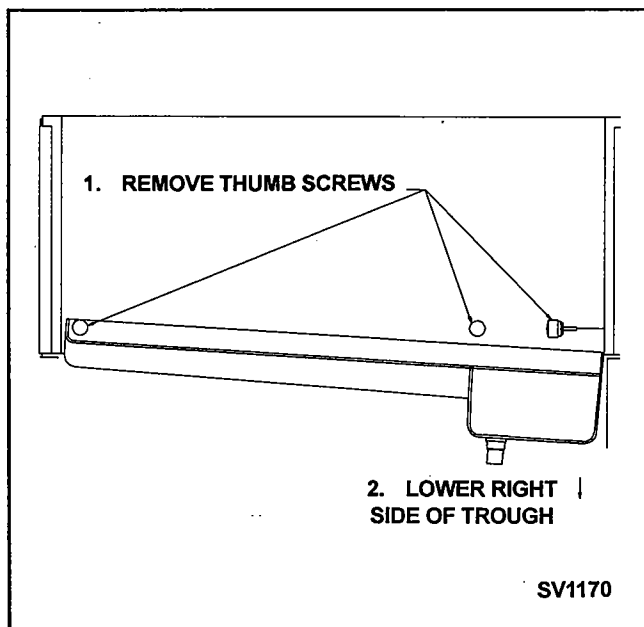

FIGURE 16. WATER TROUGH REMOVAL

Cleaning Procedures

Ice Machine Cleaner is for the removal of lime scale or other mineral deposits. It is not used for the removal of algae and slime.

CAUTION

Use only Manitowoc Ice Machine Cleaner (Part No. 94-0546-3) in recommended concentration, as this is compatible with materials used in the manufacture of Manitowoc Ice Machines.

1. Soak the parts in a solution of no more than 16 ounces of cleaner to one gallon of warm water. Use a brush (**DO NOT USE A WIRE BRUSH**) or a sponge to clean the parts, taking care not to damage them.

CAUTION

Do not immerse the water pump motor in the cleaning solution. Also, use care when cleaning the ice bridge thickness probe so as not to move the adjusting screw.

2. Use the cleaning solution and a brush or sponge to remove any scale build-up from the top, sides and bottom extrusions, the inside of the ice machine panels, and the entire inside of the ice bin.

A dirty top protrusion, Figure 13, could result in uneven water flow over the evaporator. Ensure all scale and dirt are removed.

3. Thoroughly rinse all the washed parts and surfaces with clean water.

NOTE

Incomplete rinsing of the ice bridge thickness probe could leave residue which could cause the ice machine to go into premature harvest. For best results, brush or wipe the probe off while rinsing it, and wipe it dry.

4. Reinstall all parts removed for cleaning, except the front panel and the top chute (if stacked).

Cleaning the Evaporator

NOTE

Failure to clean other parts prior to the evaporator may result in poor cleaning of the evaporator surface.

1. Turn on the water to the ice machine at the water service valve, and ensure the float valve is open, Figure 12, page 9.
2. Allow the trough to fill to the proper operating level, Figure 6, page 4.
3. Set the ICE/OFF/WATER PUMP switch to WATER PUMP.
4. Add two ounces of the cleaner to the water trough, and allow the solution to circulate for a maximum of 10 minutes.

NOTE

Use a soft brush on an excessively dirty evaporator to help remove deposits. Ensure the connecting holes in the back corners of the cube molds are open.

5. Set the ICE/OFF/WATER PUMP switch to OFF.
6. Shut off the water at the float valve, Figure 12, page 9.
7. Drain the water trough by removing the overflow tube.
8. Thoroughly rinse the trough with clean water, then reinstall the overflow tube.
9. Turn on the water at the float valve.
10. Set ICE/OFF/WATER PUMP switch to WATER PUMP and allow the water trough to fill to the proper operating level.

11. Sanitize the ice machine after cleaning.
12. Perform Operational Checks, pages 4 and 5.

SANITIZING

Sanitizer is used for the removal of algae or slime, AND AFTER THE USE OF MANITOWOC ICE MACHINE CLEANER. It is not used for the removal of lime scale or other mineral deposits.

1. Loosen the screws holding the top cover in place and remove the top cover.
2. Set the ICE/OFF/WATER PUMP switch to OFF after the ice falls from the evaporator at completion of Harvest cycle, or set the switch to OFF and allow the ice to melt off the evaporator.

CAUTION

Never use any type of object to force ice from the evaporator. Damage may result.

3. Remove the water curtain, Figure 7, page 4.
4. Remove all ice from the bin.
5. Set the ICE/OFF/WATER PUMP switch to WATER PUMP.
6. Add one ounce of sanitizer to the water trough and allow the solution to circulate for a minimum of one minute.
7. Drain the solution from the trough by removing the drain plug, Figure 6, page 4.
8. Thoroughly rinse the trough with clean water, then reinstall the drain plug.
9. Wash all surfaces requiring sanitizing (ice machine and bin) with a solution of one ounce of sanitizer to up to four gallons of water.
10. Thoroughly rinse all sanitized surfaces with clean water.
11. Set the ICE/OFF/WATER PUMP switch to ICE.
12. Perform Operational Checks, pages 4 and 5. Discard the first batch of ice.

WATER FILTRATION

Manitowoc recommends the use of water filtration on the water supply to the ice machine. Filtration reduces mineral build-up on the ice making surfaces of the ice machine. This can slow the ice making process, reduce ice production, increase energy consumption and increase cleaning frequency. Filtration also improves ice quality. If the local water supply is highly turbid (dirty water), a prefilter is also recommended.

Consult your local dealer or distributor for information on Manitowoc's full line of Tri-Liminator filtration systems.

To ensure maximum filtration efficiency, replace the primary filter cartridge every six months. The filter gauge will indicate if replacement is necessary prior to six months usage (a reading below 20 psig).

Tri-Liminator systems which include a prefilter should not require primary filter replacement prior to six months' usage. If replacement is indicated, first replace the prefilter.

Replacement Procedure (Figure 19)

1. Turn off the water supply using the inlet shut-off valve.
2. Depress the pressure release button to relieve any pressure.
3. Unscrew the housing from the cap (see illustration).
4. Remove the used cartridge from the housing and discard it.

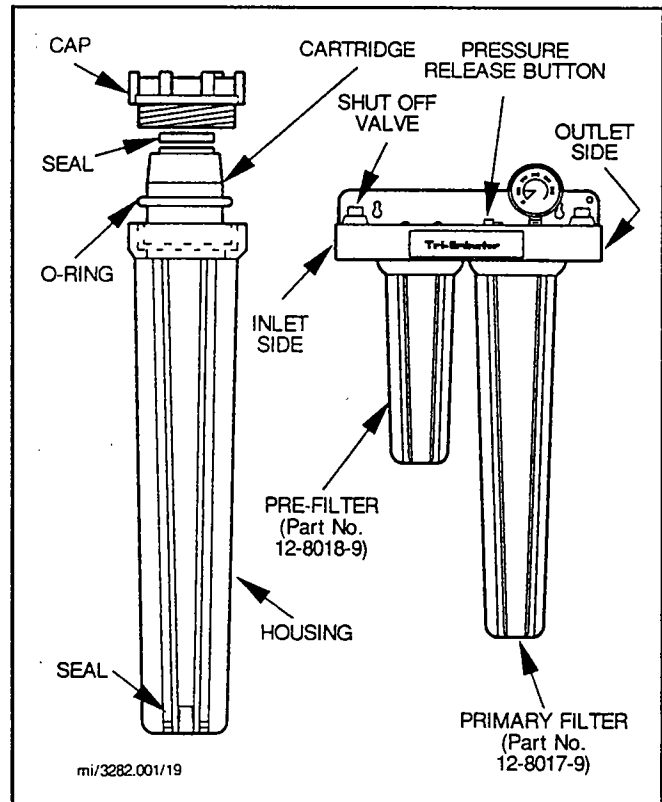

FIGURE 19. WATER FILTRATION

5. Remove the O-ring from the groove in the housing. Wipe the groove and the O-ring clean. Relubricate the O-ring with a coating of clean petroleum jelly (Vaseline). Place the O-ring back in the groove and, with two fingers, press it down into the groove.

NOTE

This is important to insure a proper filter seal. Make sure the O-ring is seated levelly in the groove.

6. Insert a new cartridge into the housing, making sure that it slips down over the housing standpipe.

7. Screw the housing onto the cap and **hand tighten. Do not over-tighten or use a spanner wrench.**
8. Repeat steps 3 through 7 for each filter housing.
9. Turn on the water supply to allow the housing (and the filter) to slowly fill with water.
10. Depress the pressure release button to release any trapped air from the housing. Check for leaks.

REMOVAL FROM SERVICE/WINTERIZATION

You must take special precautions if the ice machine is to be removed from service for extended periods, or exposed to ambient temperatures of 32°F or below.

CAUTION

If any water is allowed to remain in the machine in freezing, ambient temperatures, it could freeze. This will cause severe damage to some components. A failure of this nature is not covered by warranty.

Self-Contained Air-Cooled Machines

1. Disconnect the electric power at the circuit breaker or the electric service switch.
2. Turn off the water going to the ice machine.
3. Remove the overflow tube from the water trough.
4. Disconnect the drain line and the incoming ice making water line at the rear of the ice machine.
5. Blow compressed air in both incoming water openings. Drain the opening in the rear of the machine until water is no longer coming out of the float valve or the drain.
6. Ensure that no water is trapped in any of the machine's water lines, drain lines, distribution tubes, etc.
7. If the machine is outside, cover the machine to prevent exposure to the elements.

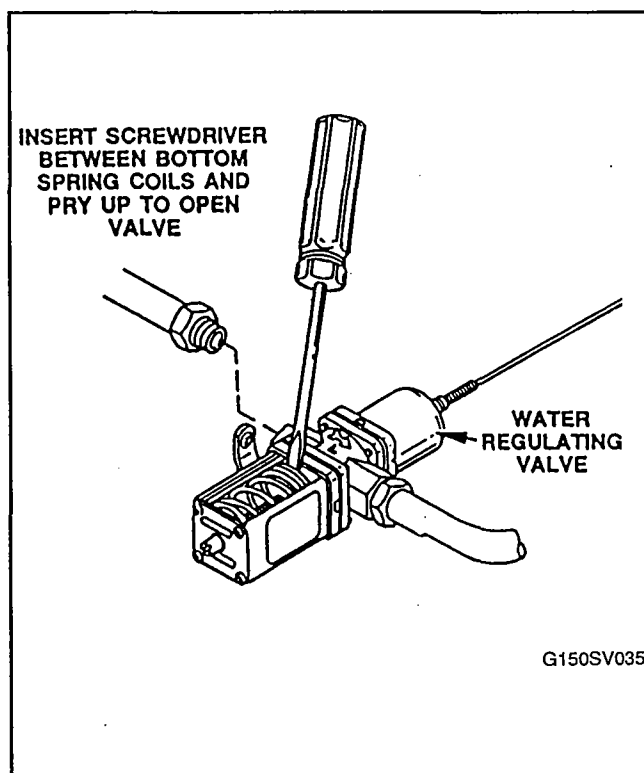

FIGURE 20. MANUALLY OPEN WATER REGULATING VALVE

Water-Cooled Machines

1. Perform all procedures listed under "Self-Contained Air-Cooled Machines."
2. Disconnect the incoming water line and the drain line from the water-cooled condenser.
3. Locate the water regulating valve in the compressor compartment.
4. Pry open the water regulating valve by inserting a large standard screwdriver between the bottom spring coils of the valve. Pry the spring upward to open the valve, Figure 20.
5. Hold the valve open and blow compressed air through the condenser until no water remains.

SECTION 4 BEFORE CALLING FOR SERVICE

If a problem arises during the operation of your ice machine, follow the checklist below before calling for service.

CHECKLIST

Problem	Possible Cause	To Correct
The ice machine does not operate.	There is no electrical power to ice machine.	Replace the fuse, reset the circuit breaker, turn on the main switch.
	A tripped high pressure cutout.	Reset the high pressure cutout.
	The ICE/OFF/WATER PUMP switch is set improperly.	Set the switch to ICE.
	The Water Curtain is stuck open.	The Water Curtain must swing freely, Figure 7, page 4.
	The Bin Switch activating pin out of adjustment.	Adjust the Bin Switch activating pin, Figure 8, page 5.
The ice machine does not release any ice or is slow to harvest.	The ice machine is dirty.	Clean and sanitize the ice machine, pages 8 and 11.
	The ice machine is not level.	Level the ice machine.
	Air-cooled models: low ambient temperature.	The minimum ambient temperature is 50°F.
	The Water Regulating Valve is leaking during harvest mode (water-cooled ice machines).	See Water-Cooled Condenser, page 8.
The ice machine does not cycle into the harvest mode.	The Ice Thickness Probe is dirty.	Clean and sanitize the ice machine, pages 8 and 11.
	The Ice Thickness Probe wires are disconnected.	Connect the wires.
	The Ice Thickness Probe is out of adjustment.	Adjust the Ice Thickness Probe. Figure 9, page 5.
	The ice is filling unevenly (thin at the top of the evaporator).	See Shallow or Incomplete Cubes, page 15.
The ice quality is poor (Ice soft or not clear.)	The quality of the incoming water is poor.	Contact a qualified service company to test the quality of the water and make the appropriate filter recommendations.
	The ice machine is dirty.	Clean and sanitize the ice machine, pages 8 and 11.
	The water softener is working improperly (if installed).	Repair the water softener.

Problem	Possible Cause	To Correct
There are shallow or incomplete cubes, or an incomplete ice fill pattern on the evaporator.	The Ice Thickness Probe is out of adjustment.	Adjust the Ice Thickness Probe, Figure 9, page 5.
	The Water Trough level is too high or too low.	Adjust the Float Valve. Figure 6, page 4.
	The Water Float Valve filter screen is dirty.	Clean the Filter Screen, Figure 12, page 9.
	The ice machine is dirty.	Clean and sanitize the ice machine, pages 8 and 11.
	The water filter is dirty.	Replace the filter, Figure 19, page 12.
	Hot water is being piped into the ice machine.	Connect the ice machine to a cold water supply. See the Installation Instructions.
	There is incorrect incoming water pressure.	The water pressure must be 20-80 psi.
	The ice machine is not level.	Level the ice machine.
There is low ice capacity.	The Water Float Valve Filter Screen is dirty.	Clean the Filter Screen, Figure 12, page 9.
	The Float Valve Shut-Off is closed.	Open the Shut-Off Valve, Figure 12, page 9.
	The incoming water supply is shut off.	Open the Water Service Valve.
	The Float Valve is stuck open.	Clean and adjust the Float Valve, Figure 12, page 9.
	The Condenser is dirty.	Clean the Condenser (air-cooled, page 7, water cooled, page 8).
	The ambient temperature is too high.	The maximum ambient temperature is 90°F.
	There is inadequate clearance around the ice machine, causing an air flow restriction.	Provide adequate clearance.
	Objects are stacked on or around the ice machine, blocking air flow to the condenser (air-cooled models).	Remove the objects.

ICE MACHINE WARRANTY

Manitowoc Ice, Inc., hereinafter referred to as the COMPANY, warrants new Ice Machines manufactured by the COMPANY to be free from defects in material and workmanship under normal use and service for a period of twenty-four (24) months from the date of original installation, and thirty-six (36) additional months on the evaporators and compressors. The obligation of the COMPANY under this warranty is limited to the repair or replacement of parts or assemblies that in the COMPANY'S opinion are defective, F.O.B. the factory.

In addition to the component warranty explained above, the COMPANY will pay straight time labor to repair or replace a defective component when failure occurs within twenty-four (24) months from the date of original installation and only when such service is performed by a COMPANY Contracted Service Representative or a refrigeration service agency as qualified and authorized by the COMPANY'S local Distributor.

Time and hourly rate schedules, as published from time to time by the COMPANY, apply to all service procedures. Additional expense including, but not limited to, overtime premium, travel time, material cost, accessing or removal of the ice machine, is the responsibility of the owner along with all maintenance, adjustments, cleaning and ice purchases.

The foregoing warranty shall not apply to (1) any part or assembly that has been altered, modified, or changed; (2) any part or assembly that has been subject to misuse, abuse, neglect, or accidents; or (3) any ice machine that has been installed and/or maintained inconsistent with the technical instructions provided by the COMPANY.

The sixty (60) month compressor warranty, including the twenty-four (24) month labor replacement warranty, shall not apply when the Ice Machine's refrigeration system is modified with a condenser, heat reclaim device, or parts and assemblies other than those manufactured by the COMPANY, unless the COMPANY approves these modifications for specific locations in writing.

THIS WARRANTY IS IN LIEU OF ALL OTHER WARRANTIES OR GUARANTEES OF ANY KIND, EXPRESSED OR IMPLIED, INCLUDING ANY IMPLIED WARRANTY OF MERCHANTABILITY OR FITNESS FOR A PARTICULAR PURPOSE EXCEPT AS PROVIDED IN THIS WARRANTY WITH RESPECT TO DEFECTS IN MATERIAL AND WORKMANSHIP. The liability of the COMPANY arising out of the sale, use or operation of the COMPANY'S parts and equipment, whether in warranty, contract, negligence or strict liability, including claims for special, indirect or consequential damages, shall not in any event exceed the cost of furnishing a replacement for a defective part or assembly as hereinabove provided. Upon the expiration of the warranty period, as hereinabove provided, any such liability shall terminate. The foregoing warranty shall constitute the sole and exclusive liability of the COMPANY.

To secure prompt and continuing warranty service, the warranty registration card must be completed and sent to the COMPANY within five (5) days from the installation date.

Complete the following and retain for your record:

Distributor/Dealer _____

Model Number _____ Serial Number _____

Installation Date _____

MANITOWOC ICE, INC.

2110 S. 26th St., P.O. Box 1720, Manitowoc, WI 54221-1720
Telephone: 920-682-0161
Form 80-0373-3 (1/88)

Telefax: 920-683-7879

Effective September 1, 1988, in the United States, Canada, and international markets served by Manitowoc.

MANITOWOC ICE, INC.

2110 South 26th Street, P.O. Box 1720, Manitowoc, WI 54221-1720 U.S.A.

Telephone 920-682-0161