

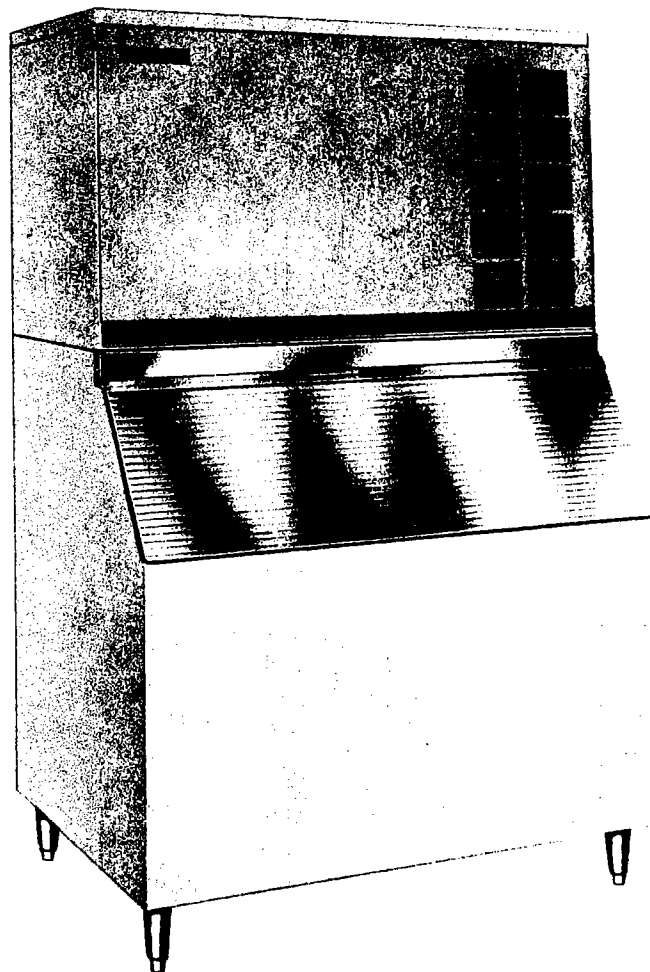

# Manitowoc

## "C-1100" SERIES ICE CUBERS SERVICE MANUAL



**Manitowoc equipment works**

Division of The Manitowoc Company, Inc..

**MANITOWOC  
WISCONSIN**

This manual covers the C1100 Series Cubers  
starting with Serial Number 81120001

80-0095-3  
6-1-81

---

## MODELS

This manual covers the following models:

CR-1100A	CR-1101W	CR-1190N
CD-1102A	CD-1103W	CD-1192N
CY-1104A	CY-1105W	CY-1194N
CY-1114AS	CY-1115WS	CY-1184NS

## TABLE OF CONTENTS

Introduction .....	Page 1
Freight Information .....	Page 2
Installation .....	Pages 2-4
Operating Procedure .....	Pages 4-5
Electrical Sequence .....	Pages 8-14
Refrigeration Cycle.....	Pages 15-16
Control Operations and Settings.....	Page 17
Remote CO-1190N Cuber .....	Pages 18-20
General Information .....	Page 18
Installation .....	Pages 18-19
Operating Procedure .....	Page 20
Refrigeration Cycle.....	Page 20
Cleaning Instructions .....	Pages 22-23
Winterizing Cuber .....	Page 23
Service Diagnosis.....	Page 24
Warranty .....	Page 25

### **CONGRATULATIONS!**

We are pleased that you have selected a Manitowoc ice cube machine. Superior design along with quality materials and workmanship have made Manitowoc the dependability leader in ice producing equipment.

### **PRINCIPLES OF OPERATION**

With the toggle switch in the ICE position the cuber produces ice and will automatically stop and start to maintain a full bin.

Ice forms in the evaporator with a "bridge" interconnecting all cubes. The water distribution tubes directs an even flow of water across the evaporator surface (cube plate). By surface tension the water tracks up the underside of the forward slanted horizontal sections. While "wetting" the entire cavity surface, sufficient heat is removed causing some water to freeze to the evaporator. As water freezes, more enters the system under control of the float valve. Freezing continues until cube formation is complete with some surface "dimple" and a connecting bridge of about 1/8" thickness.

The ice bridge control determines the ice production time. When the suction pressure reaches a predetermined level the ice bridge control opens a hot gas solenoid valve to begin the harvest mode. Hot refrigerant gas passes through the evaporator tubing. This causes some meltage, freeing the cube waffle and allowing it to slide forward and fall into the storage bin.

When the "cube waffle" drops from the evaporator, it hits the water curtain. Some cubes separate during this contact and more will separate when they strike the bin or stored ice. It is normal to have some cube clusters, especially when the bin is almost full. Your machine is operating properly when a single waffle of interconnected cubes is harvested.

The falling cubes push the water curtains out, activating the bin switches which closes the hot gas solenoid valve and starts the water pump. Another ice production cycle begins. When the storage bin is full, ice holds the water curtain out and the cuber shuts down. Removing ice from the bin permits the curtain to swing back to its normal position which starts the machine.

When the harvest mode begins the water pump stops, allowing the water in the distribution tube and connecting line to enter the sump and drain through the overflow elbow. This "bottom flushing" removes accumulated lime and minerals, but still retains some 32° F. water for the next production mode.

Manitowoc cubes are purer than the water from which they are made. Why? As the water cascades over the evaporator only pure water tends to freeze. The lime, minerals, etc. continue to circulate through the system until they are "flushed" at the beginning of the harvest mode. By eliminating impurities and air during the formation process, the cubes are pleasingly clear for all types of cooling applications.

## FREIGHT DAMAGE AND LOSS INFORMATION

The transportation company, dealer, or contractor who delivers this merchandise is responsible for loss and/or damage. If the transportation company made direct delivery, we suggest you follow the steps outlined below.

### A. SHORTAGES

1. Check number of cartons delivered with the quantity shown on your receipt.
2. If quantities do not tally, have driver note shortage and file your claim accordingly.

### B. VISIBLE DAMAGE

1. If cartons appear damaged in any way, open the carton and inspect the contents in the driver's presence.
2. To remove the cuber carton, cut the banding and slide the carton up and off of the cuber.
3. Have the driver note the nature and extent of the damage on the freight bill.
4. Notify the transportation company's office to inspect the merchandise. Carrier claim rules require inspection within 15 days of delivery.

### C. CONCEALED DAMAGE

1. If damage is noticed later when the ice machine or storage bin is unpacked, notify the transportation company immediately and ask to have an inspection.
2. Do not destroy packing materials until inspection is complete.
3. Unless these conditions are met, it is very difficult to have your claim accepted by the transportation company.

### D. FILING CLAIMS

1. File claim for loss or damage at once. In your claim with the transportation company, you may elect to:
  - a. Make a cash adjustment
  - b. Arrange to have repairs made, or
  - c. Replace the merchandise

## INSTALLATION OF SERIES C-1100

We strongly recommend that the installation and "start and adjust procedure" be performed by a trained and competent technician. However, if you elect to perform these operations yourself, the following information will serve as a comprehensive guide.

### LOCATION

For best performance select a location away from radiators, ovens, refrigeration condensing units, direct sunlight and other sources of heat.

Allow a minimum of 5 inches clearance around the cuber for air circulation. Restricted air flow over an air cooled condenser will adversely affect ice production.

An air cooled cuber will perform more efficiently in a 70° F. room than in a 90° F. room. Recommended room temperature should not range below 55° F. nor above 100° F.

If the cuber is located in an unheated area, it must be protected from freezing temperatures or shut down and winterized. Refer to "Winterizing Cuber" Page 23.

### SET-UP OF THE ICE STORAGE BIN

1. Open the top of the ice storage bin carton. Lay the carton on it's back. Remove the internal corrugated packing and place on the floor adjacent to the bin top. Slide the bin from the carton onto the cardboard packing to prevent scratching. Screw the legs into the bin bottom.
2. Set the bin in general location and level by adjusting the legs. The foot of the leg will screw up or down for adjustment.

**REMOVAL OF PACKING AND INSTALLING CUBER**

1. To remove the cuber carton, cut the banding and slide the carton up and off of the cuber.
2. Set and align the cuber on the bin. Care should be taken to prevent tearing the 1/8" foam tape around the bin top.
3. If you desire the bin lid to stay in the open position when raised, install the bin door latch P/N 07-0041-3 supplied with the C-900 bin.
4. To remove the front and rear panels, remove the four screws on each side and lift the panel slightly up and out. The rear compressor compartment panel and top panel should also be removed.
5. Remove the water pump, sump trough, ice chutes, and water curtains. Remove corrugated shipping blocks from under the evaporators and any tape used to secure components during shipping.
  - a. Set the sump trough in place.
  - b. Set the front and rear ice chutes in place.
  - c. Plug in the water pump service cord and hang the pump on the mounting studs. Place the water tubes on the pump discharge stubs.
  - d. Hang the water curtains over the evaporators. Curtains should swing freely.
  - e. If the harvest racks have to be removed, push fastener in and turn 90° to remove.
6. Remove the water inlet strainer. It will be installed later in the ice making water inlet line. Remove the wooden wedges from under the compressor.

**WATER & DRAIN REQUIREMENTS AND CONNECTIONS (Refer to Fig. 1)**

All water and drain connections should conform to local and national codes. We recommend installing a shut-off valve in both the ice making and condenser water lines. All water and drain lines should be covered with insulation to prevent condensation.

The ice making cold water supply is connected to a 1/4" female pipe fitting in the rear panel. Use 3/8" O.D. copper tubing. Install the water strainer in this line with the arrow toward the cuber and the clean-out plug down.

The condenser water supply is connected to a 1/2" female pipe fitting in the rear panel. Use a minimum of 1/2" O.D. copper tubing. A minimum of 25 pounds per square inch condenser water pressure must be maintained at the cuber for proper operation.

Drain connections should not allow waste water to back up into the cuber or storage bin. Drain lines must have a 1-1/2" drop per 5 feet of run. If drains are not close enough to allow proper drainage, or water is to be drained in a stationary sink, an automatic condensate pump will be required.

The bin and cuber drain lines should run **separately** to an open trapped or vented floor drain. The cuber drain lines require a minimum 1/2" I.D. tubing and are connected to a 1/2" female pipe fitting. The bin drain line requires a minimum 3/4" I.D. tubing and is connected to a 3/4" female pipe fitting. The cuber base drain and bin lines should be vented to atmosphere.

**ELECTRICAL REQUIREMENTS AND CONNECTIONS — Figure "1"**

				<b>Min. Circuit Amps</b>	<b>Max. Circuit Fuse</b>
Air Cooled (self-contained)	208/230	1 ph.	60 cy.	13.2 Amp	20 Amp
Water Cooled	208/230	1 ph.	60 cy.	12.6 Amp	20 Amp
Air Cooled (self-contained)	208/230	3 ph.	60 cy.	9.0 Amp	15 Amp
Water Cooled	208/230	3 ph.	60 cy.	8.4 Amp	15 Amp

All electrical connections should conform to local and national codes. The combination serial and electrical plate is located inside the cuber above the water pump. The model and serial numbers should always be used to identify your machine when parts and/or service are required.

The cuber should be connected to a separately fused circuit. Fuse size must not exceed maximum fuse size

shown on the electrical plate. The supply voltage should not vary more than, 208V -5% and 230V +10%. All electrical wiring must be rated equal to or greater than the minimum ampacity shown on the electrical plate.

Remove the electrical service box cover and connect the supply wires to the screw terminals marked L1 and L2 on single phase, and L1, L2, and L3 on three phase units. Connect the ground wire to the green screw provided in the box. Replace box cover.

### INSTALLATION CHECK LIST

1. Is the cuber level?
2. Has all the internal packing been removed; tape, compressor blocks, etc.?
3. Have all the electrical and water connections been completed?
4. Has the supply voltage been tested and checked against the rating on the nameplate?
5. Is there 5" clearance around the cuber for proper air circulation?
6. Is the cuber installed where ambient will not vary below 55° F. or above 100° F.? Are you prepared to winterize? See "Winterizing Cuber."
7. Is there a separate drain for the water cooled condenser?
8. Has the water strainer been installed in incoming ice making water line?
9. Are the base and bin drains vented? ---
10. Check to be sure refrigerant and electrical lines are not touching one another.
11. Are all the following components in place and secured? Ice chutes, water curtains, water pump, harvest rack, overflow elbow, water distributors, connecting lines, and float valve.
12. Do the water curtains swing freely and are bin switches adjusted properly? (See Fig. 2)
13. Has the storage bin been cleaned?
14. Turn on the ice making water supply and the condenser water supply (if water cooled) and check for and repair any leaks. The back panels and top panel can now be replaced.

### OPERATING PROCEDURE

1. Place the ON-OFF toggle switch in the WATER PUMP position. Only the water pump will operate. Check for proper water flow through the distributor tubes and over the evaporators.
2. With the pump operating, the water level is automatically maintained by the float valve. The water level should be approximately 1/4" below the top of the overflow elbow. If adjustment is needed carefully bend the float rod until the proper water level is obtained.
3. Turn the water pump on and off at approximately one minute intervals. Do this three times to flush clean water through the system and inspect for proper drainage.
4. Turn on the cuber by placing the toggle switch in the ICE position; the compressor water pump, and fan motor will operate.
5. Bin switch operation: These switches cycle the cuber from the harvest to the freeze mode and turns the cuber off when the storage bin is full of ice. (See Fig. 2 for adjustment). Pulling either the front or rear water curtains to the center of the ice chute will trip the corresponding bin switch shutting down the entire cuber. The cuber will remain off until the water curtain is released.
6. Check bridging of cubes and adjust if needed. For optimum ice production and maximum cube

separation, the ice connecting the individual cubes should be approximately 1/8" thick. Bridge thickness will vary slightly from top to bottom.

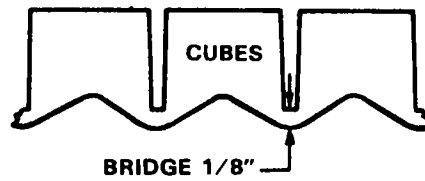

To change bridge thickness, an adjustment of the ice bridge control is required. This control is located above the ice making compartment and can be adjusted without removing the control box cover.

To adjust — turn black knob, clockwise to decrease ice bridging and counterclockwise to increase ice bridging.

FIG. 1

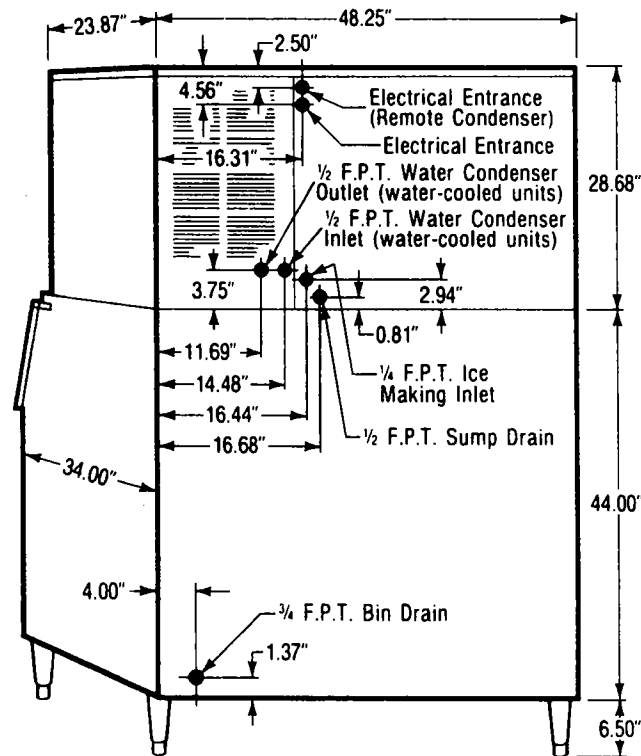

Series 1100 Cuber  
C-900 Bin, 606 Adjustable Legs

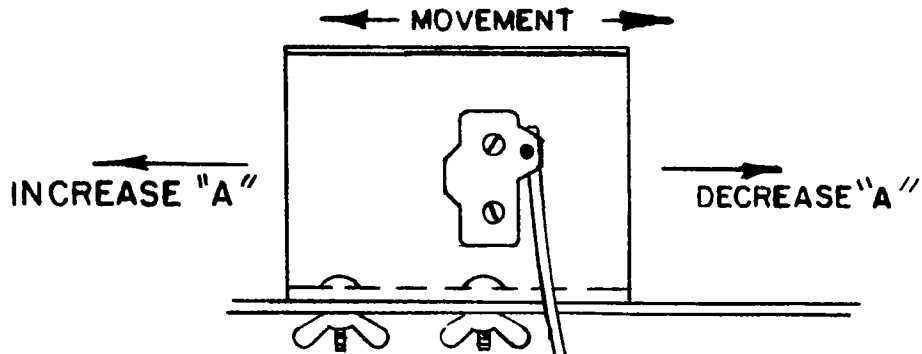

FIG. 2

**INSTRUCTIONS TO POSITION BIN SWITCH**

1. Micro-switch location is important to cuber operation.
2. Optimum "A" Dimension for micro-switch activation is 1/4".

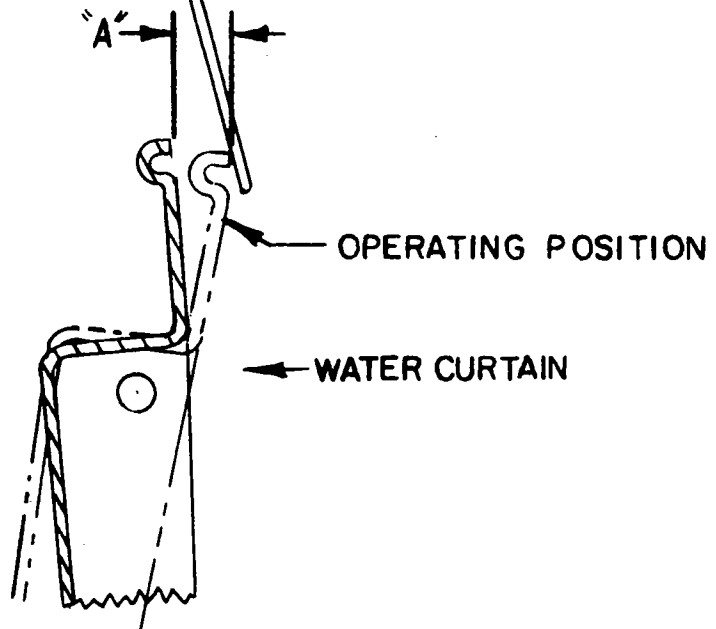
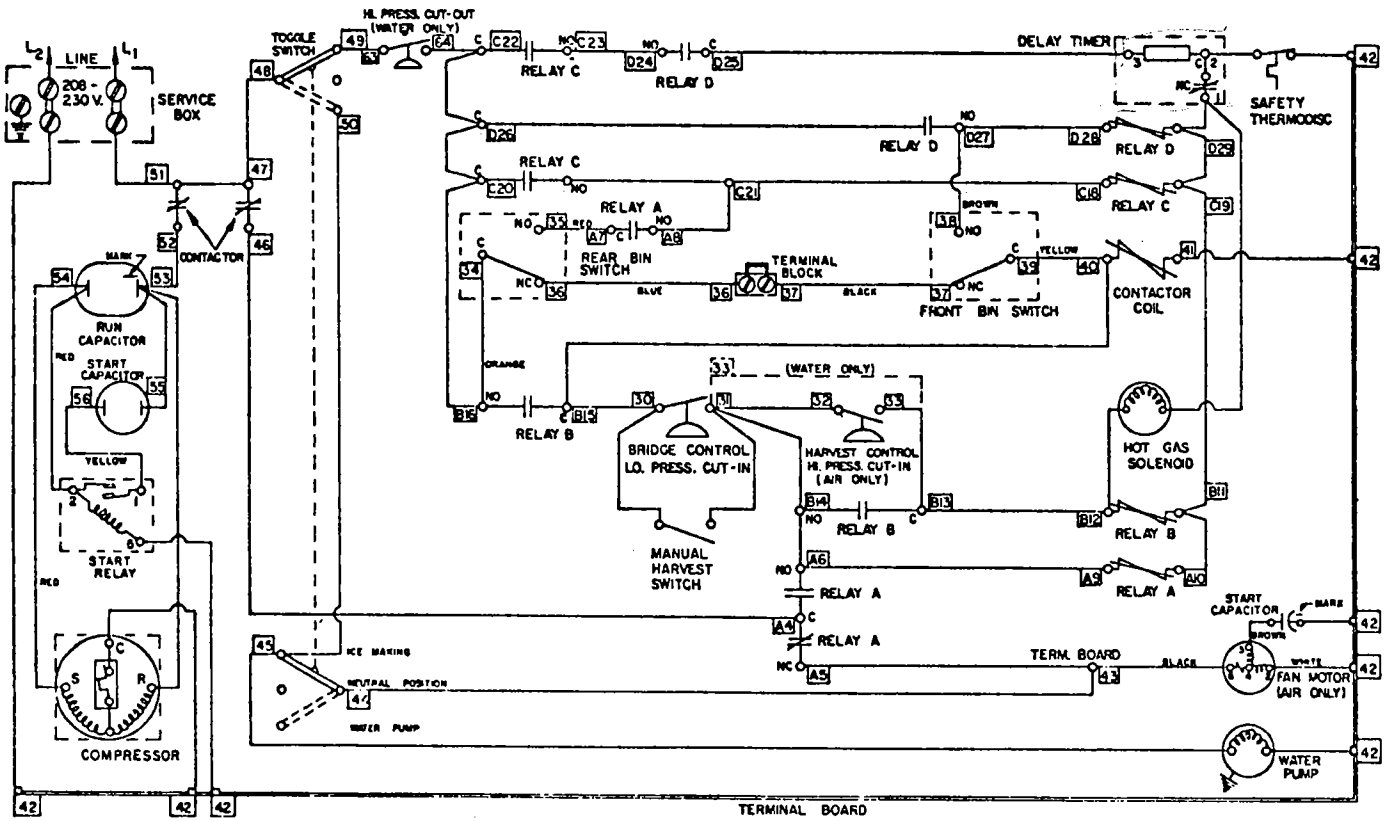

FIG. 3

**RELAY HOOK-UP INSTRUCTIONS**

1. Assembly — Carefully push terminal up into relay. Check position.
2. Disassembly — Utilize a screwdriver to remove terminal.  
CAUTION — Do not pull terminal out by leads.





C-1100 WIRING DIAGRAM, AIR AND WATER 208/230 V. 60 HZ. 1 PHASE

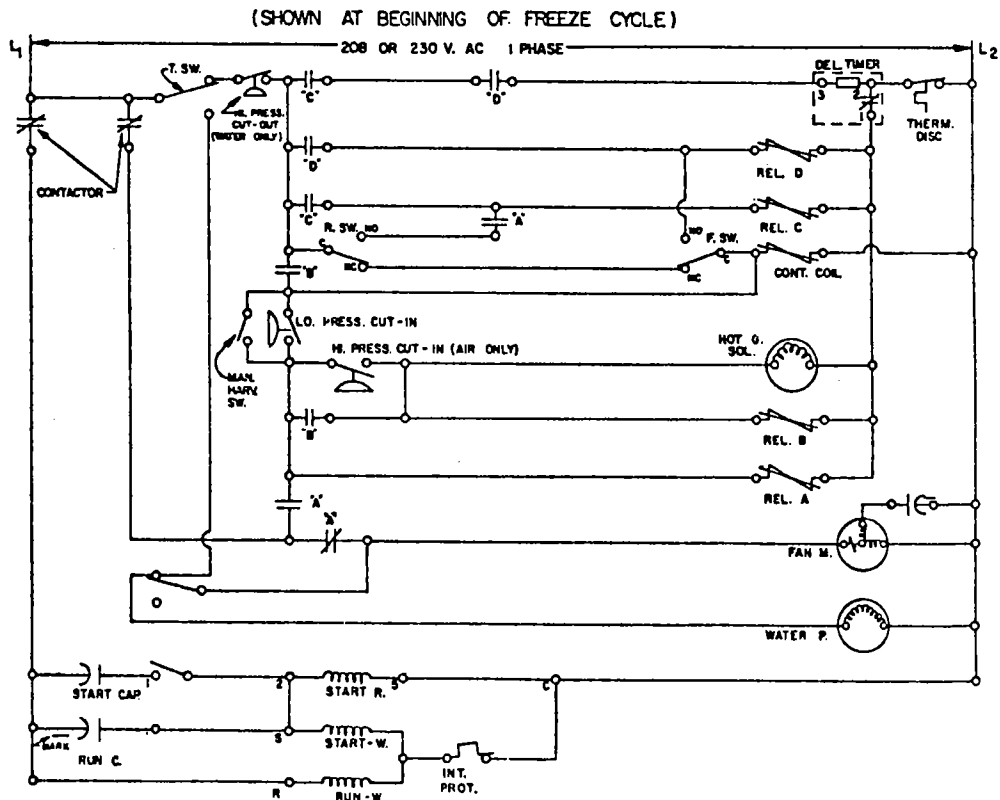

ELECTRICAL SEQUENCE OF OPERATION

Sequence I — Freeze Mode, diagram (a)

1. The ice making cycle is started by placing the toggle switch to the ice making position. This will energize the contactor through the toggle switch, high pressure cut-out (water cooled units) and the two bin switches. The contactor will inturn start the compressor, water pump, and fan motor (on air cooled units.) The cuber is now in the freeze mode.

DIAGRAM (a)

(SHOWN AT BEGINNING OF FREEZE CYCLE)

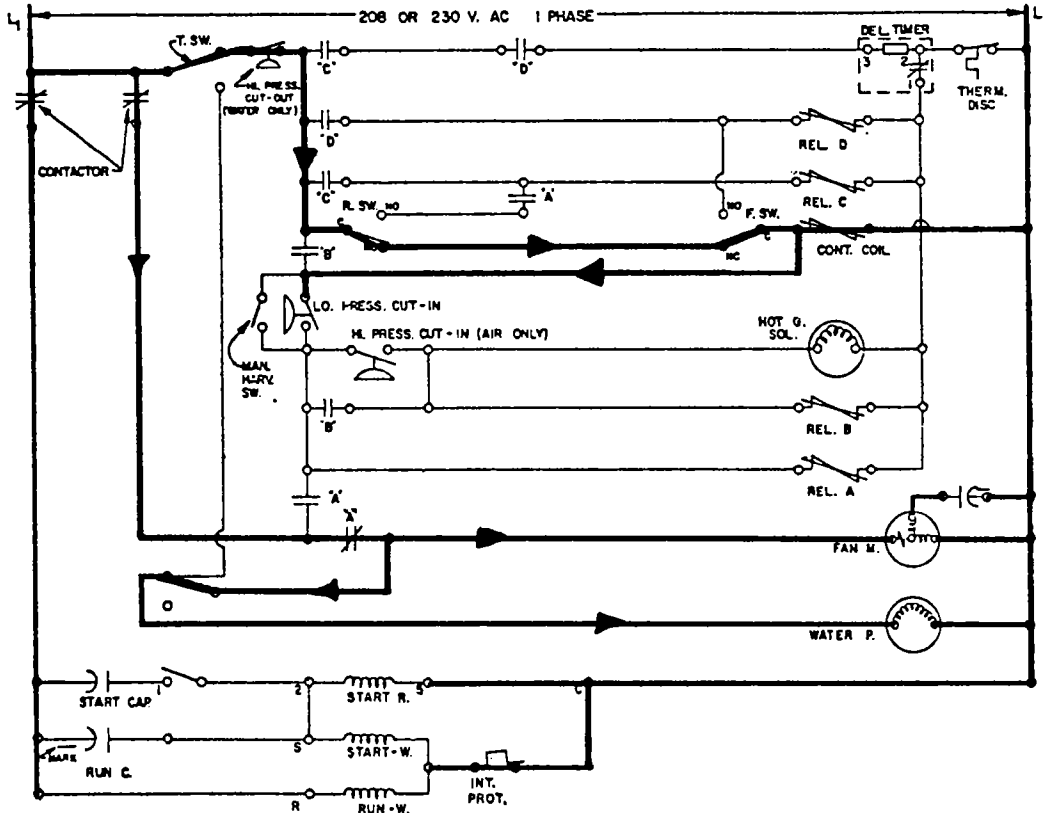

2. Units with remote condensers use a pump down system. Placing the toggle switch in the ice making position will energize the liquid line solenoid. The unit will not start for a few moments while the suction pressure equalizes through the solenoid. When the suction pressure reaches approximately 27 PSIG the low pressure cut-out control will close its contacts energizing the contactor inturn starting the cuber.

(SHOWN AT BEGINNING OF FREEZE MODE)

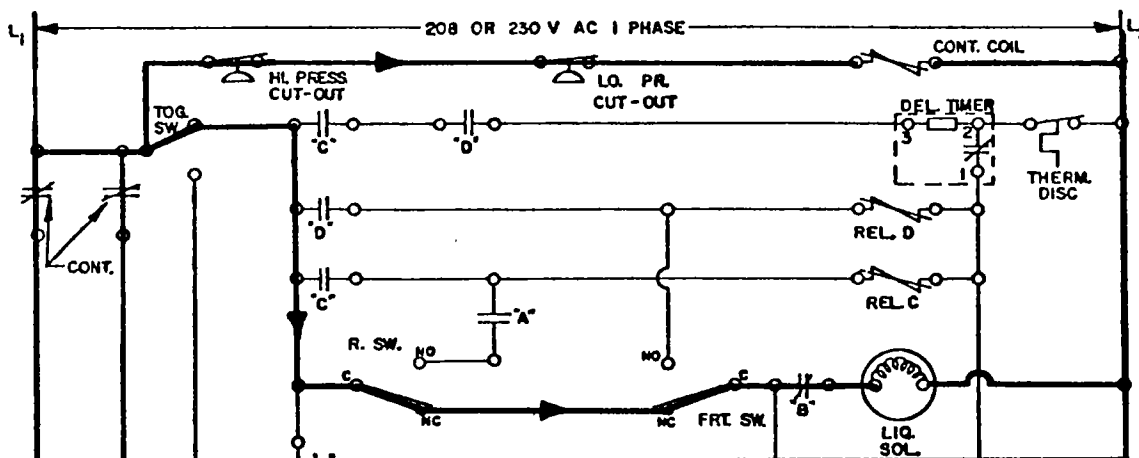

**Sequence II — Beginning of Harvest Mode, diagram (b)**

As the cuber continues to run and ice forms on the evaporator plates, the suction pressure will continually decrease. At approximately 10.5 PSIG the reverse acting low pressure cut-in control (ice bridge control) will close its contacts, ending the freeze mode.

**Diagram (b) — Water Cooled and Remote Units Without High Pressure Cut-In Control**

Closing of the low pressure cut-in control contacts will immediately energize relays "A" and "B" and the hot gas solenoid valve starting the harvest mode on water cooled and remote units.

Shortly after the hot gas valve opens the low pressure cut-in control will re-open its contacts.

Energizing relay "A" will de-energize the water pump and fan motor and lock in the hot gas solenoid valve through contacts "A."

Energizing relay "B" will lock in the contactor coil through contacts "B." On remote units, energizing relay "B" will de-energize the liquid solenoid. See No. 2 in Sequence I.

**DIAGRAM (b)**

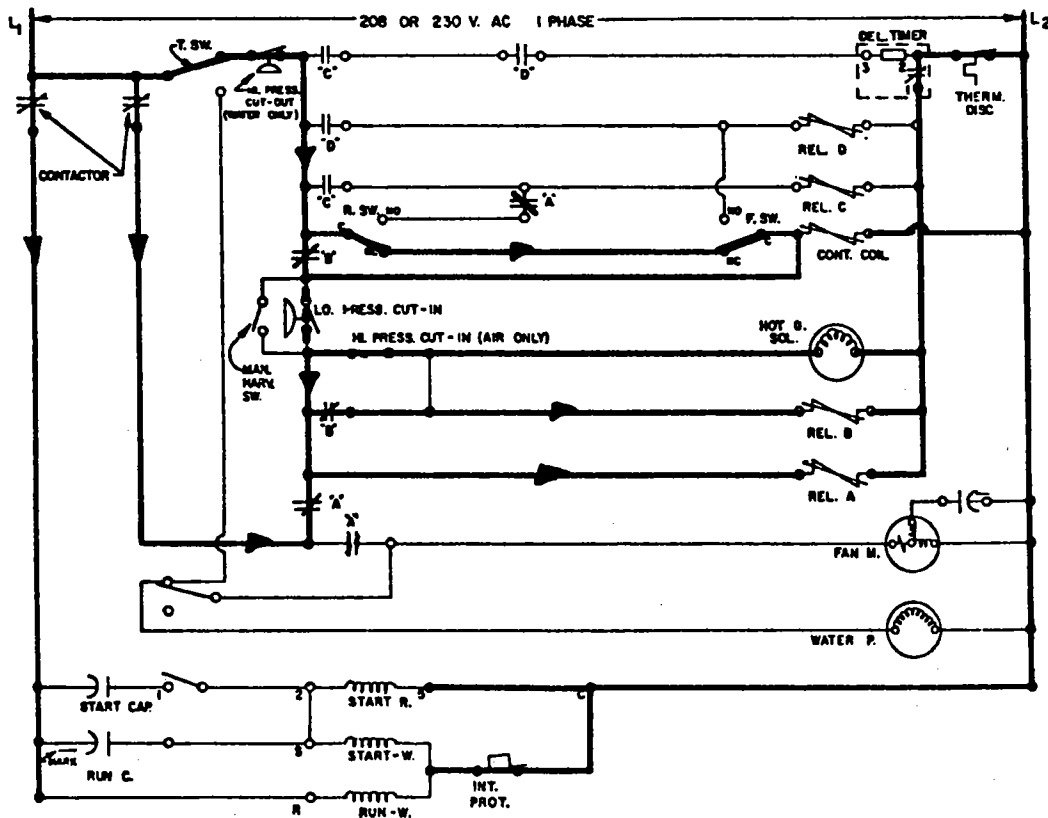

Sequence II (continued)

Diagram (c) and (d) — Selfcontained Air Cooled Units With High Pressure Cut-In Control

1. Diagram (c) — Closing of the low pressure cut-in control contacts immediately energizes relay "A" which inturn de-energizes the water pump and fan motor. With the fan motor off the head pressure will rise until it reaches the high pressure cut-in control setting of 160 PSIG. This can be immediately or up to 30 seconds, depending on room temperature. This gives the unit a consistent head pressure going into the harvest mode, even in low room temperatures.

DIAGRAM (c)

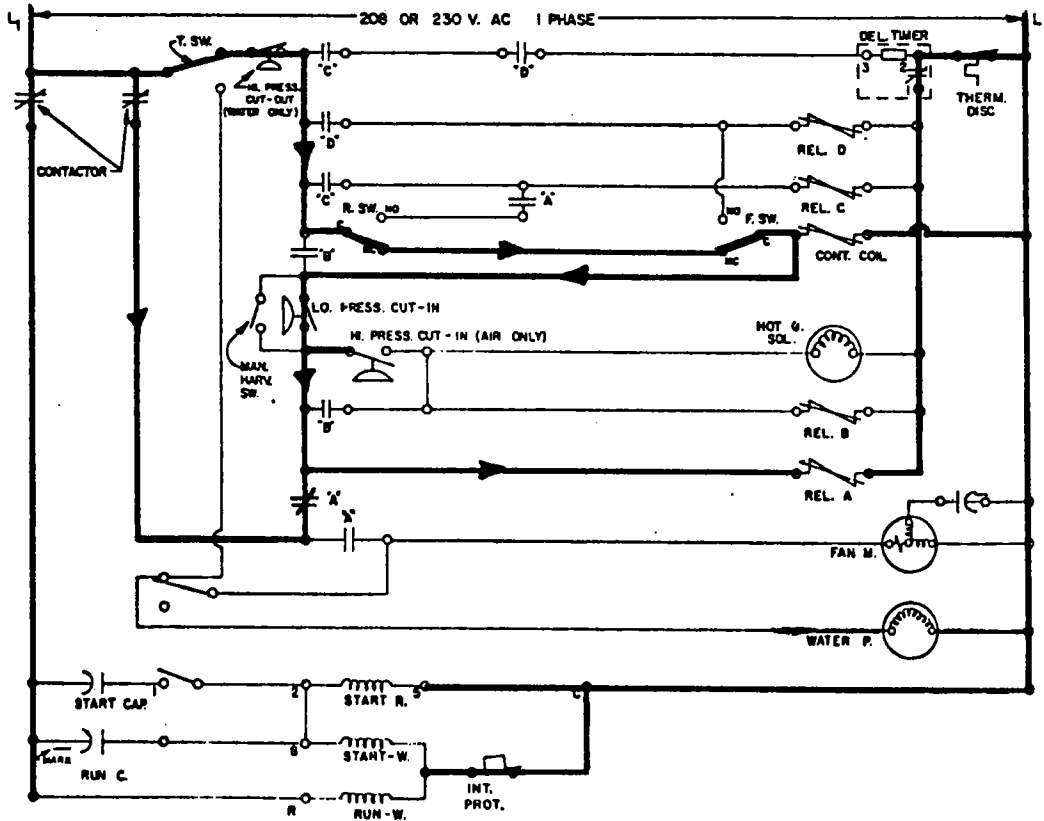

Sequence II (continued)

- Diagram (d) — Closing of the high pressure cut-in control contacts will immediately energize the hot gas solenoid valve and relay "B."

Energizing of relay "B" will lock in the hot gas solenoid and the contactor coil through contacts "B." Shortly after the hot gas valve opens the head pressure will drop, opening the high pressure cut-in control contacts and the suction pressure will rise opening the low pressure cut-in control contacts.

DIAGRAM (d)

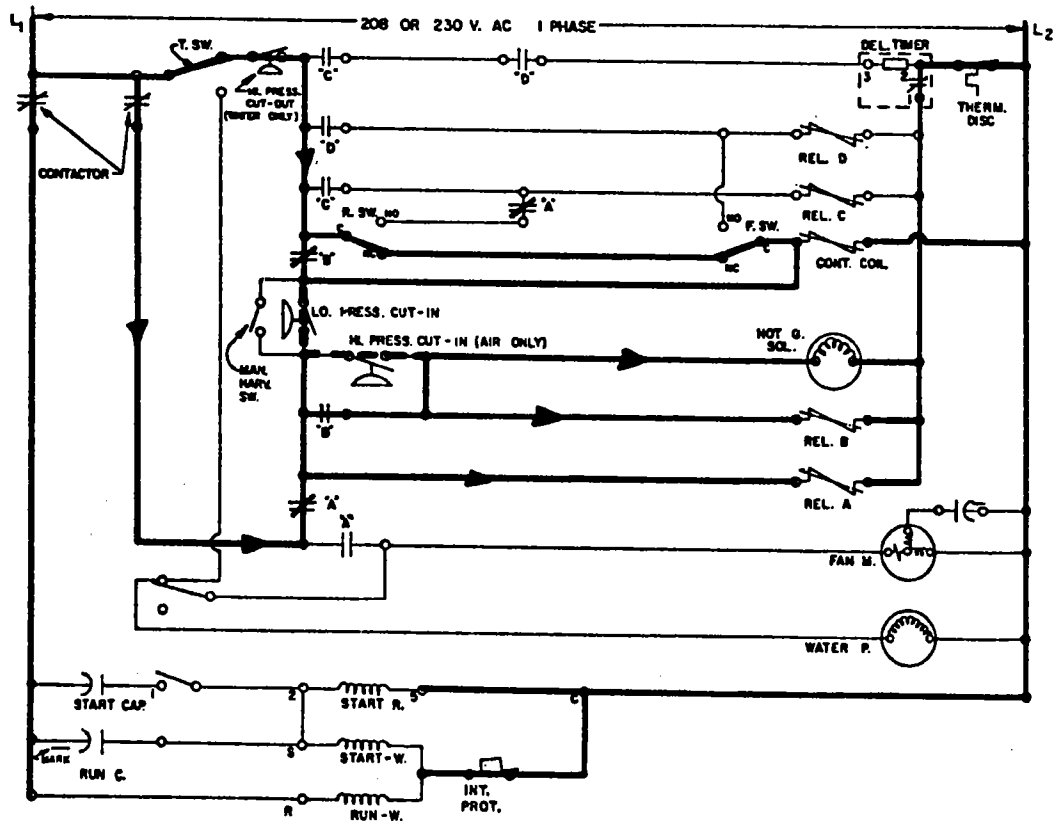

Sequence III — Completion of Harvest

The hot gas solenoid valve will remain energized through relays "A" and "B" until both the front and rear evaporators harvest the ice.

There is no sequence as to which evaporator harvests first. Both evaporators must drop to end the harvest mode.

Diagram (e) — Relay "C" is energized when the rear ice drops tripping the rear bin switch.

DIAGRAM (e)

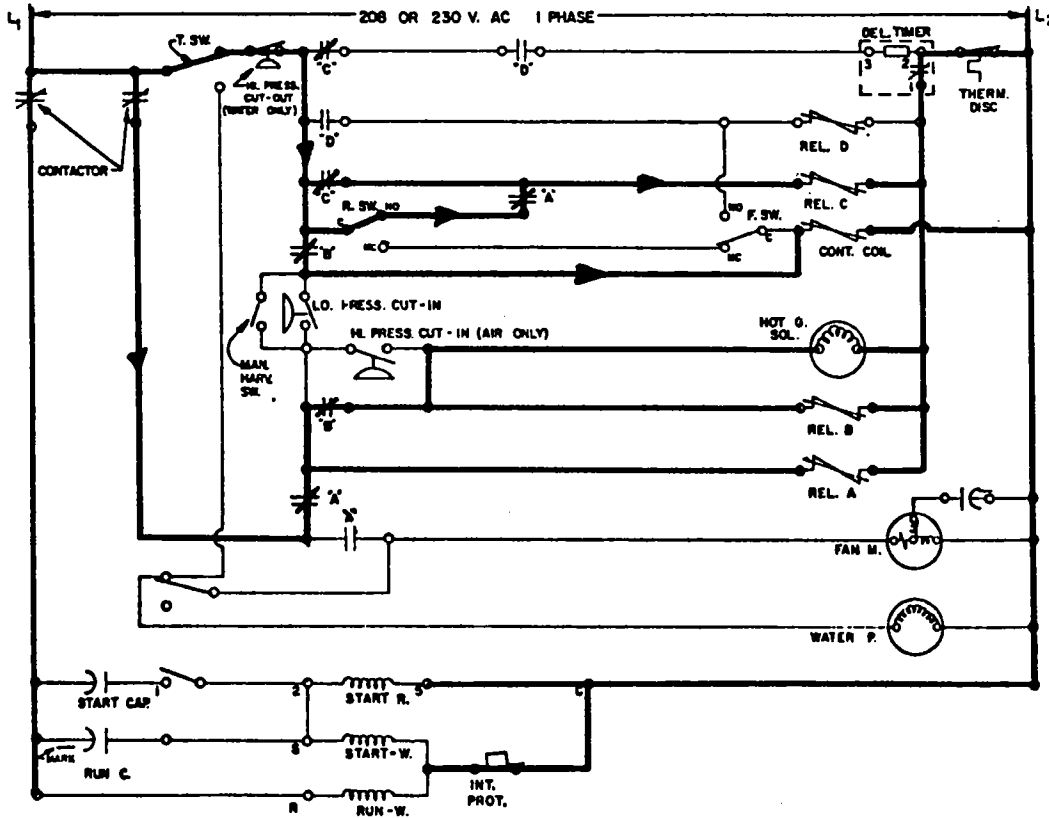

Sequence III (continued)

Diagram (f) — Relay "D" is energized when the front ice drops tripping the front bin switch.

When both evaporators have harvested, the 6 second delay timer is activated through relay "C" and "D" contacts.

DIAGRAM (f)

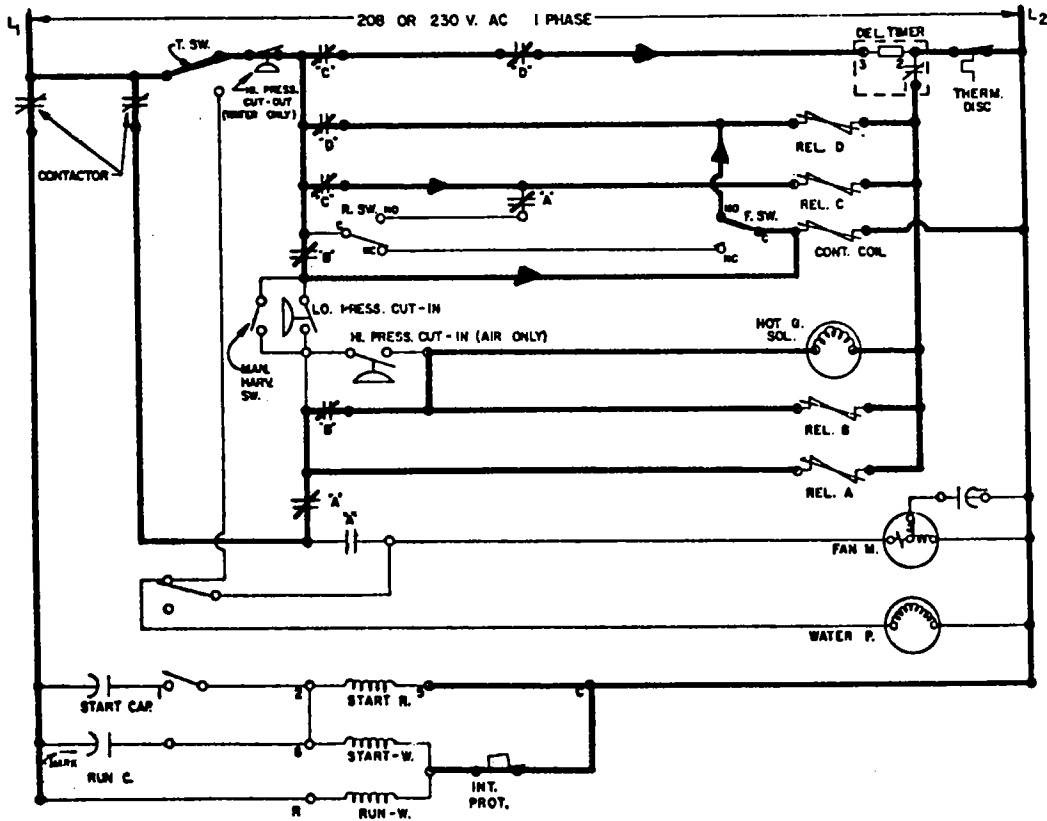

*Sequence III (continued)*

Diagram (g) — After the 4-6 second delay, the delay timer contacts between terminals 1 and 2 momentarily open (see \* in upper right hand corner of diagram (g)) de-energizing the four relays and the hot gas solenoid valve, starting a new ice making cycle.

The contactor remains energized through the bin switches preventing the compressor from cycling off after each harvest.

DIAGRAM (g)

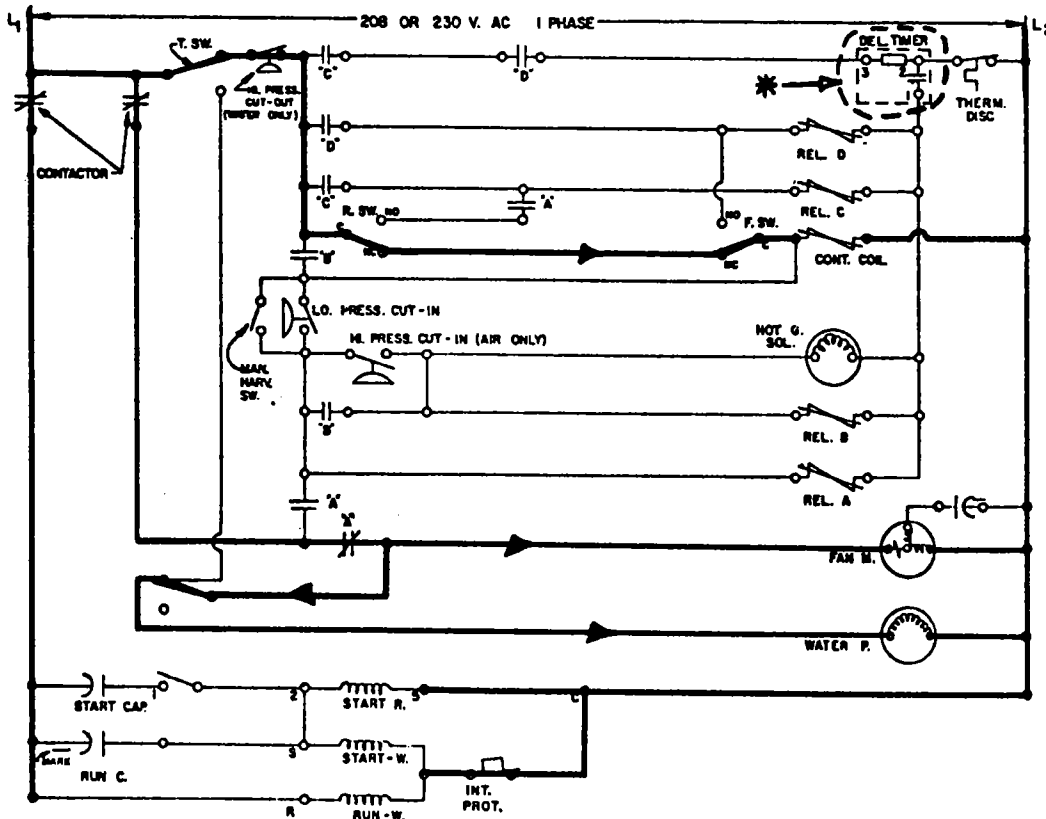
**Sequence IV — Automatic Cycling of Cuber**

If the front or rear bin switch should stay open, because of a full bin of ice, the contactor would de-energize, shutting the cuber off. As the ice is removed from the bin, the water curtain would allow the bin switch to reclose, energizing the contactor starting a new ice making cycle.

On remote units opening either bin switch would de-energize the liquid solenoid causing the unit to pump down and shut off on the low pressure cut-out. See No. 2 in Sequence I.

**REFRIGERATION CYCLE — Figure "4"**

(Assume operating conditions are 90° F. air and 70° F. water)

**FREEZE CYCLE —**

During the freeze cycle, the high pressure discharge gas is pumped into the condenser (air cooled — average head 145 PSIG; water cooled — average head 135 PSIG) see chart below. The gas is condensed to a high pressure liquid. The liquid leaves the condenser goes through the filter-drier and into the heat exchanger. On water cooled units the liquid would go from the condenser and into the receiver. The receiver stores extra refrigerant when it is not used — this depends on operating conditions.

The high pressure liquid leaves the heat exchanger at a reduced temperature, making the system more efficient. The high pressure liquid is then metered into the evaporators by two thermostatic expansion valves, one expansion valve for each evaporator. The expansion valves regulate the rate of refrigerant liquid flow into the evaporator in the exact proportion to the rate of evaporation of the refrigerant liquid in the evaporator. The expansion valve does this by responding to (a) the pressure in the evaporator (2) the temperature of the refrigerant gas leaving the evaporator using the expansion valve feeler bulb to sense the gas temperature.

After the low pressure liquid evaporates to a low pressure gas, it will tee into a common suction line and pass through the heat exchanger. The average suction pressure will start in the low 20's PSIG and drop to approximately 10-11 PSIG at the time the cuber goes into harvest.

**HARVEST CYCLE**

The harvest is initiated by the ice bridge control energizing the hot gas solenoid valve, allowing high pressure hot gas to flow through the evaporator and harvest the ice. The suction pressure at this time is in the range of 40-60 PSIG. The cuber goes back into the freeze cycle automatically when the solenoid valve is closed by the harvesting ice tripping the bin switches.

**C-1100 SERIES OPERATING PRESSURES**

	Air Temp. °F	AIR COOLED		WATER COOLED	
		Freeze Cycle	Harvest Cycle	Freeze Cycle	Harvest Cycle
HEAD PSIG	55	115-95	75-85	135-125	80-90
	70	125-110	80-95	"	"
	80	140-125	90-100	"	"
	90	160-140	100-115	"	"
	100	185-155	105-120	"	"
SUCTION PSIG	55 to 100	24-10	35-65	24-10	35-48
TOTAL CYCLE TIMES	55 to 100	16-27 Minutes		16-23 Minutes	

The above operating pressures and times can vary depending on the operating conditions.

FIG. 4  
REFRIGERATION SCHEMATIC C-1100

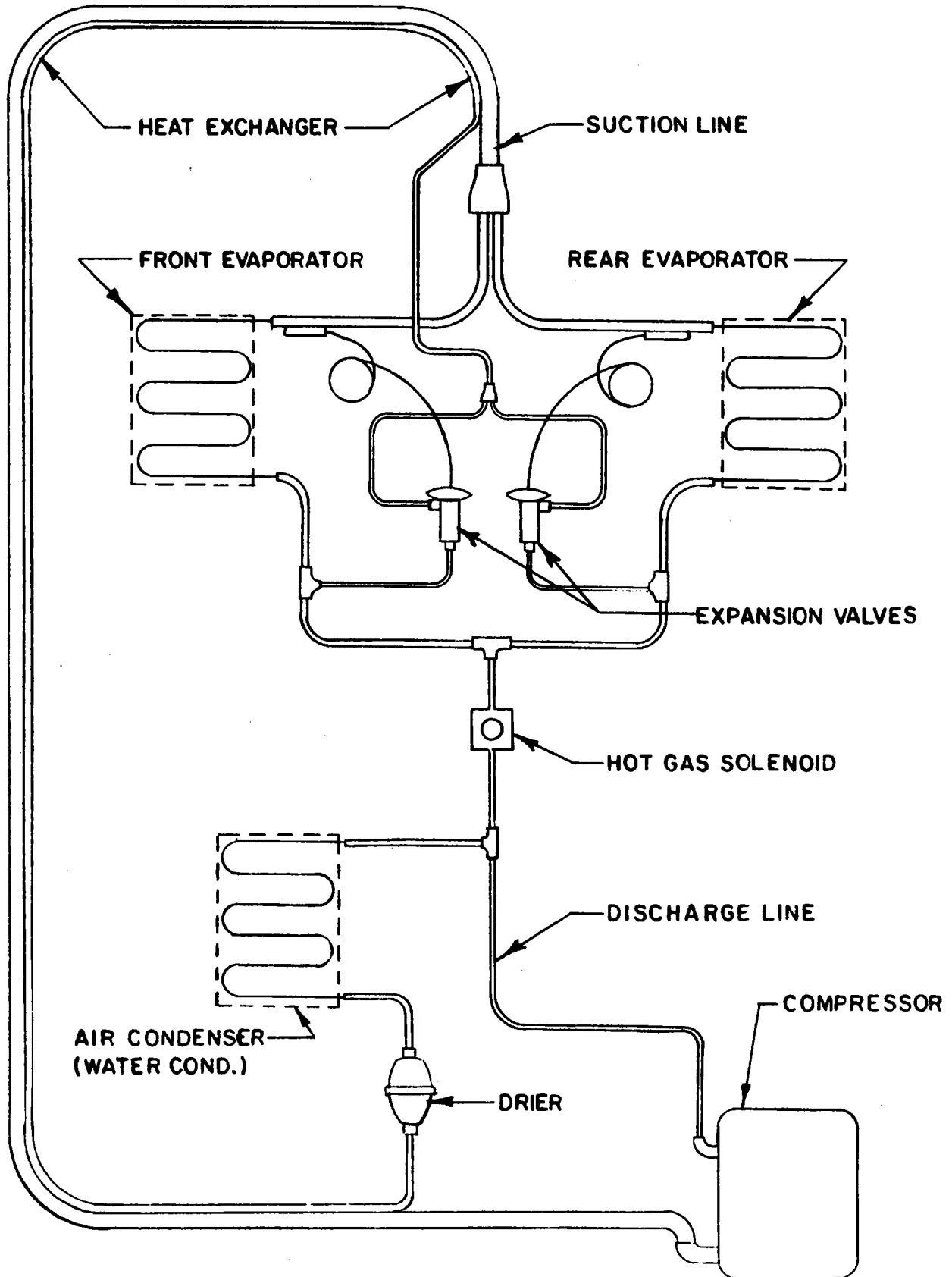

## CONTROL OPERATIONS AND SETTINGS

**ICE BRIDGE CONTROL** — Its primary function is to control the ice bridging thickness and to initiate the harvest mode by energizing the hot gas solenoid valve. It is a low pressure cut-in control that closes its contacts on a fall in pressure and is set at approximately 10-1/2 PSIG and will re-open at approximately 20-21 PSIG.

The adjustment range is approximately 1 to 1-1/2 PSIG per 180° turn, a clockwise adjustment will increase the cut-in point, decreasing the bridge size. The knob can be removed for further service adjustment, this should only be done by a qualified service technician.

Care must be taken not to turn adjustment more than 360° in either direction with knob removed. The differential is a fixed setting.

**HIGH PRESSURE HARVEST CONTROL** — Is a high pressure cut-in control used on the self-contained air cooled units only. This assures a high head pressure to aid the harvest in low ambient conditions by delaying the energizing of the hot gas valve until the head pressure reaches 160 PSIG. It will re-open at 140 PSIG. If the head pressure is above 160 PSIG when the ice bridge control cuts in, the hot gas solenoid will immediately energize.

To adjust, turn the phillip head screw clockwise to increase the cut-in point. The differential is a fixed setting.

**SAFETY HIGH PRESSURE CUT-OUT SWITCH** — Is used on the water cooled and remote systems. Its contacts open on a rise in head pressure and is set to trip at approximately 275 PSIG. The opening of the control contacts will shut the entire cuber off. This control must be manually reset by pushing the metal tab in.

**BIN MICRO-SWITCHES, FRONT AND REAR** — Operate off the top of the water curtains. The bin switches are activated when the ice drops out of the evaporators. Tripping of both switches in any order, will end the harvest and start a new freeze cycle. If either bin switch should be held open by a full bin of ice the cuber will shut off.

To adjust, loosen the wing nuts and slide the switch assembly to achieve proper trip point as shown in Figure "2," page 6.

**DELAY TIMER** — Is set at 6 seconds and prevents the contactor and compressor from momentarily cycling off after every harvest. To check operation while cuber is in freeze mode:

1. Place volt meter leads across terminals 1 & 3 of delay timer.
2. Push the manual harvest button, relays A & B should energize (on self-contained air cooled models energizing of relay B is delayed until the harvest control closes).
3. Trip the rear bin switch arm by pushing the metal arm momentarily with a screwdriver.
4. Then trip the front bin switch momentarily, this should immediately energize the timer indicated by a voltage reading on the volt meter.
5. After 6 seconds the contacts should open, indicated by no voltage reading and de-energizing of all the relays.
6. If the delay timer does not end the harvest in 6 seconds check to see if the resistor is mounted across the two top unmarked terminals. If the resistor is mounted properly, you can assume the timer needs to be replaced. **Symptom**, unit cycles back into freeze mode on the thermodisc, 2-3 minutes after the ice drops.
7. If the delay timer contacts open immediately after the second bin switch is tripped, replace timer. **Symptom** of no delay would be the contactor and compressor momentarily de-energizing after each harvest.

**LOW PRESSURE CUT-OUT CONTROL** — Used on remote systems only, is set to open its contacts at 2-3 PSIG suction pressure and reclose at approximately 28 PSIG. This control cycles the cuber on the suction pressure and is used in conjunction with the liquid line solenoid valve to pump the system down when the cuber is turned off at the toggle or bin switches.

To adjust, turn the phillip head screw clockwise to increase the cut-in point. The differential is a fixed setting.

## CO-1190N CUBER WITH AC-1195A REMOTE CONDENSER

Cuber Model Numbers:   CR-1190N           CY-1194N  
                              CD-1192N           CY-1184NS

Condenser Model Number: AC-1195A

Precharged Line Model Numbers: RT-20, RT-35, RT-50, MRT-28, MRT-60, MRT-75

### GENERAL INFORMATION

The cuber head sections listed above are used with the AC-1195A condenser and one of the precharged line sets listed above, designated by the customer, for each condenser.

Note: The standard CO-1100 self-contained cuber is not designed to be used with the AC-1195A remote condenser.

The CO-1190N cuber and the AC-1195A condenser are designed to be used with one of the "RT" or "MRT" line sets. Manitowoc cannot be responsible for the ice machine operation when the cuber is installed with non-approved remote condensers and/or line sets.

The precharged lines, cuber head, and remote condenser are all shipped in separate crating. The ice making sections of the standard CO-1100 and CO-1190N cubers are identical.

### INSTALLATION

Set-up cuber per the instructions on page 2.

#### REMOTE AIR CONDENSER SET-UP

1. Assemble two legs to each of the two mounting tracks. This assembly provides for two separate height adjustments. The standard 12 inch height and a 15 inch height to be used in installations where heavy snow or debris may collect at base of condenser causing air flow restrictions.
2. Locate the remote condensers in a well ventilated area on the roof. If the cuber is located above condenser, maximum recommended height is 12 feet.
3. Using the six mounting holes provided, secure the remote condenser to the roof. Seal with tar or pitch to prevent entrance of moisture.

#### INSTALLING THE REFRIGERATION LINES

1. Each condenser is connected with two precharged lines. The precharged line sets ordered separately from the condenser to suit each individual application.

The precharged line lengths are 20 ft. (RT-20), 35 ft. (RT-35), 50 ft. (RT-50), 28 ft. (MRT-28), 60 ft. (MRT-60), and 75 ft. (MRT-75).

2. Remove the tubing from the carton. Carefully unwind the coil so the tubing doesn't become kinked.
3. The refrigerant fittings on the cuber and remote condenser are oiled at the factory, however, additional lubrication is needed to prevent the 'o'-ring from moving. Use refrigeration oil only.
4. Note: The precharged lines are provided with a 90° bend at one end. This end is intended to be attached to the cuber to provide a minimum 6 inch clearance between cuber and wall. If additional bends are required slide armflex away from tubing. Using a tube bender, carefully bend tubing to required angle.
5. Carefully thread, by hand, the female hose fitting to the male fitting on the cuber and remote condenser. Using the proper size wrench, tighten the couplings until you feel them bottom out. Then add an additional 1/4 turn to insure proper seal. If a torque wrench is used, on the 3/8" fittings the torque value is 10-12 ft. lbs. For 1/2" fittings the value is 35-45 ft. lbs.

**IMPORTANT:** Once the refrigerant lines are connected, the seal is broken in the fittings and if removed from the cuber or remote condenser, the refrigerant charge in the cuber and condenser will be depleted.

**WATER SUPPLY AND CONNECTIONS, Refer to Page 3**

Electrical Supply, 208/230 voltage 1 PH. or 3 PH.

See Serial Plate for minimum circuit amps and maximum fuse size.

**ELECTRICAL CONNECTIONS**

The electrical power supply is run into the connection box at the rear of the cuber. The remote condenser electrical hook-up is connected to the cuber and condenser as shown below.

**SINGLE PHASE**

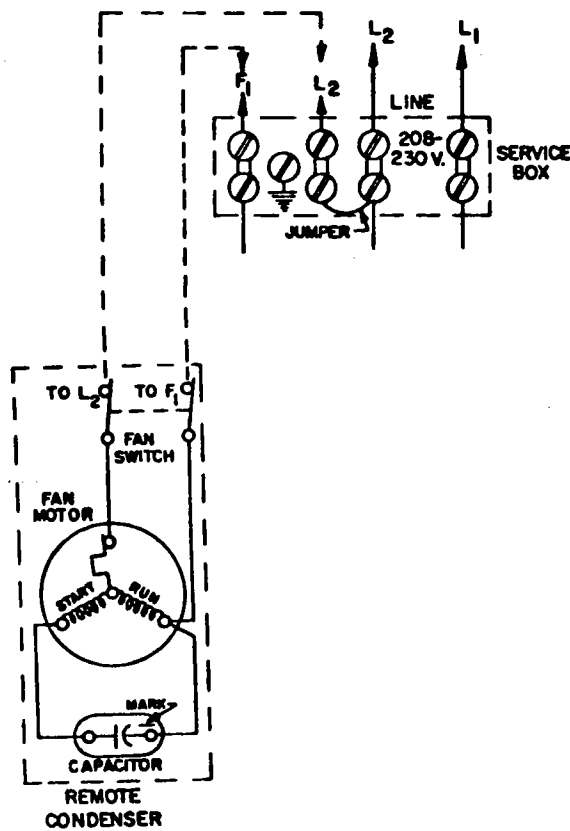

**THREE PHASE**

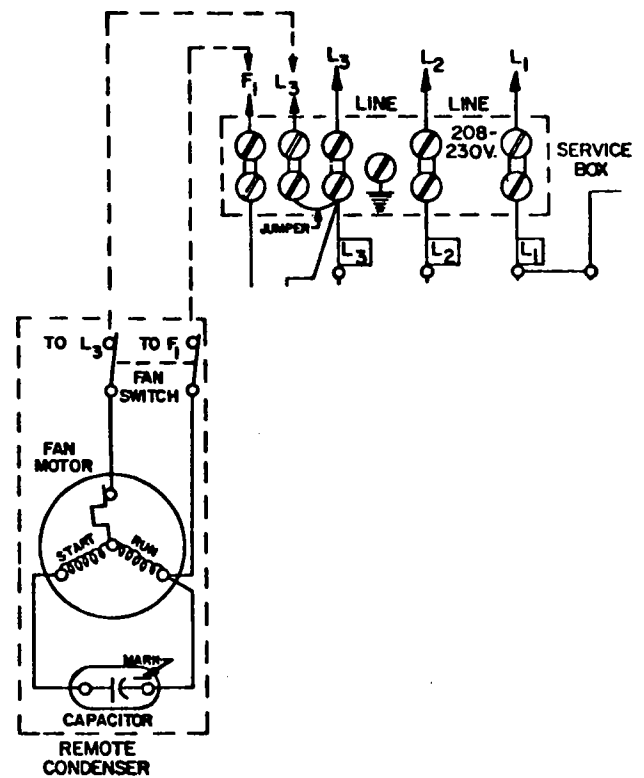

Minimum required fan motor amps. 1.2. The supply wiring and condenser fan motor wiring from the cuber to be supplied by customer. FOLLOW ALL LOCAL AND NATIONAL CODES. Ground through conduit or 3rd wire to ground screw.

## START UP

The check list and operating procedure for the remote cubers are the same as for the standard cubers, Page 4, with the following additions:

1. Before start-up, open (backseat) the receiver valve and the suction roto-lock valve.
2. After the cuber is running, check the remote air condenser and verify that the condenser fan is running. Fan will be off during the defrost cycle.

(NOTE: See Page 8 for electrical sequence of operation)

## REFRIGERATION CYCLE — CUBER WITH AC-1195A REMOTE CONDENSER — Figure "5"

### FREEZE CYCLE

During the freeze cycle the high pressure discharge gas is pumped into the remote condenser. The high pressure gas is condensed into a high pressure liquid. The high pressure liquid leaves the condenser and goes through the head pressure control valve to the receiver.

The purpose of the head pressure control valve is to maintain a minimum receiver head pressure of approximately 105 PSIG for normal system operation during low ambient temperatures (70° F. and below). Because of the pressure drop this minimum pressure will be approximately 10-15 PSIG higher at the compressor discharge valve.

During colder weather (70° F. and below) the head pressure control will gradually flood the condenser and start by-passing hot gas to the receiver to maintain 105 PSIG receiver head. An under charge will cause problems during cold weather (70° F. and below) and will show up in poor defrosting and premature energizing of the low pressure cut-in.

During hot weather (80° F. and above) the receiver will be 1/2 to 3/4 full of liquid refrigerant. An overcharge can cause problems in hot weather when the extra refrigerant charge to be stored is more than the receiver can hold.

The high pressure liquid leaves the receiver and goes through the heat exchanger reducing the liquid temperature making the system more efficient. The high pressure liquid is then metered into the evaporator by a thermostatic expansion valve. The expansion valve regulates the rate of refrigerant liquid flow into the evaporator in the exact proportion to the rate of evaporation of the refrigerant liquid in the evaporator. The expansion valve does this by responding to (1) the pressure in the evaporator and (2) the temperature of the refrigerant gas leaving the evaporator using the valve feeler bulb to sense the gas temperature.

After the low pressure liquid evaporates to a low pressure gas, it passes through the suction line heat exchanger and into the compressor. The average suction pressure will start at approximately 20 PSIG and drop to approximately 10 PSIG when the cuber goes into harvest.

### HARVEST CYCLE

The harvest is initiated by the ice bridge control energizing the hot gas solenoid valve, allowing high pressure hot gas to flow through the evaporator and harvest the ice. The suction pressure at this time is in the range of 40-60 PSIG. The cuber goes back into the freeze cycle automatically when the solenoid valve is closed by the harvesting ice tripping the bin switches.

FIG.5  
REFRIGERATION SCHEMATIC C-1100

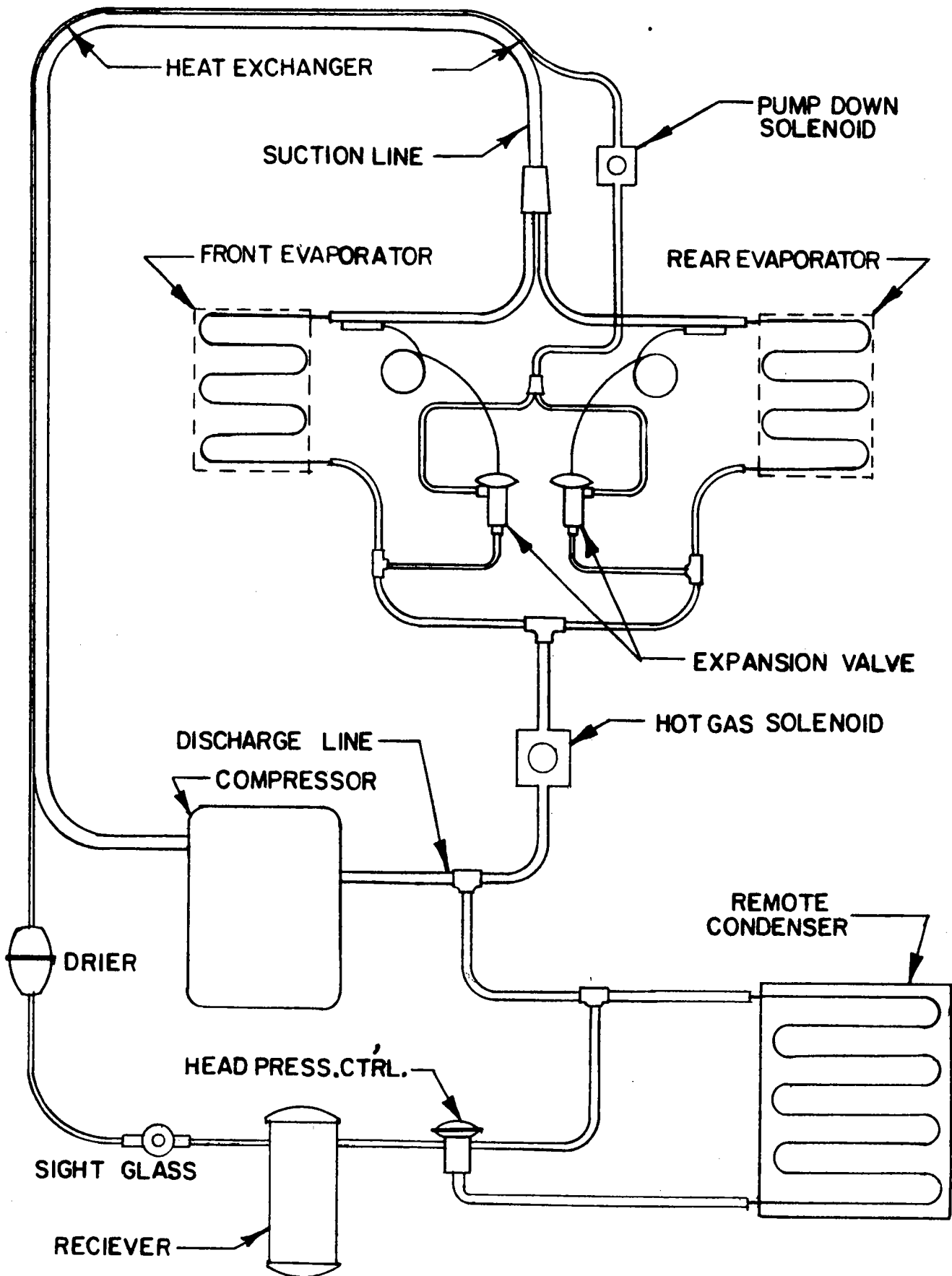

## CLEANING INSTRUCTIONS

Efficient operation requires periodic cleaning.

Cleaning frequency will depend largely on water conditions. If you have hard water or high concentrations of impurities, water treatment filters may be needed to improve ice quality and reduce cleaning frequency. Check with local water treatment firms for advice.

The ice making water supply strainer should be cleaned every time the water system is cleaned. Proceed as follows:

1. Turn off the water supply.
2. Remove the plug and strainer.
3. Clean the strainer and replace.

## CLEANING OF THE ICE MAKING SECTION

We recommend two ice machine cleaning solutions. They are Lime-A-Way from Economics Laboratories or Nickel-Safe from Calgon. Other cleaners from the same or other companies may be harmful to the nickel plating on the evaporator. Lime-A-Way can be purchased from Manitowoc ice machine distributors. Manitowoc's part number is 94-0546-9.

## IN PLACE CLEANING

To clean the water system without removing the components proceed as follows: This method is acceptable when build-up is not excessive.

1. Remove front panel.
2. Remove any existing ice in the evaporator by pushing the manual harvest button.
3. Turn cuber off and remove all ice from bin.
4. Drain the sump trough water.
5. Pour 4 oz. of Lime-A-Way or Nickel-Safe cleaner in the sump and fill with fresh water.
6. Flip the toggle switch to the WATER PUMP position. Circulate the cleaner for a maximum of 15 minutes. If not sufficiently clean, proceed to hand cleaning instructions.
7. Flip the toggle switch to the OFF position, drain the water and cleaner solution. Proceed to "Sanitizing Procedure."

## HAND CLEANING

Used when material build-up is too severe for "in place cleaning."

1. Turn the cuber and the water supply off. Remove the water pump, front and back water distributors, water curtains, sump trough, and ice from the bin.
2. Use a cleaning solution of 2 oz. of recommended cleaner per one gallon of warm water.
3. Soak the water distributor in a hot cleaning solution while cleaning the remaining parts. If necessary, the distributor tube can be disassembled.
4. Snap the water pump inlet screen out and clean.
5. Scrub all parts using a nylon brush and cleaning solution.
6. Scrub the base and evaporator assembly. Clean and flush the base drain. With a small brush, clean the weep holes in the corner of each evaporator cube cavity. Rinse with clear water.
7. Replace all the internal components and proceed to "Sanitizing Procedure."

## STORAGE BIN CLEANING

1. Scrub the bin interior with 1 oz. of recommended cleaner per gallon of water. This solution may be used to clean other water and ice contact surfaces.
2. Rinse with clear water.

### **SANITIZING PROCEDURE**

1. Reassemble unit.
2. Mix one teaspoon of sodium hypochlorate (chlorine bleach) in one gallon of water. Fill sump trough.
3. Place toggle switch in WATER PUMP position and continue to add solution until the pump is fully primed. Circulate solution for one minute.
4. Turn off water pump and drain solution from sump trough into the bin to sanitize the bin.
5. Turn on the fresh water supply and allow the sump to fill. Flush the system several times by running the water pump at 1-minute intervals and then drain the sump.
6. Flush the bin out several times with clean water.
7. Turn cuber on by placing toggle switch in ICE position.
8. Make a visual inspection for leaks, drainage and proper water level and flow. Check all components for proper location and tighten all screws before replacing front panel. See Operational Procedure for adjustment.

### **AIR COOLED CONDENSER CLEANING**

The air cooled condenser should be cleaned frequently. A dirty condenser restricts air flow, causing reduced ice production.

1. Turn off main power supply.
2. Remove the front and wrap-around panels. Most dirt will collect on the inlet side of the condenser. This is opposite the fan motor.
3. Use a bristle brush to work the dust and dirt loose and remove with a vacuum cleaner.
4. If the cuber is located in an area where grease collects on the condenser, scrub with a solution of warm water and detergent. Keep solution away from wiring and electrical components.
5. Clean fan blades.
6. Check for loose items before replacing panels.

### **WINTERIZING CUBER**

If the cuber is located in an unheated area, it must be protected from freezing temperatures or shut down and winterized. When the cuber is shut down for the winter, it is very important that all water be removed from the cuber.

1. Turn main ice water and condenser water (if water cooled) supply valves off, disconnect and drain all water lines.
2. Drain the sump trough by removing the overflow elbow.
3. On water cooled models it is very important to completely drain the condenser. After the main water supply has been disconnected, open the water regulating valve or remove the outlet line from the regulating valve. All water should be forced from the condenser with compressed air. Any water left in the condenser can freeze and cause serious damage.

**ITEMS TO CHECK BEFORE CALLING A SERVICEMAN**

If you have checked all the following and your cuber still does not operate, call a competent serviceman. Check in the Yellow Pages under Ice Making Equipment and Machines for a local Manitowoc service representative.

**SERVICE DIAGNOSIS**

<b>SYMPTOM</b>	<b>POSSIBLE CAUSE</b>	<b>CORRECTIVE MEASURE</b>
Cuber not running	Main breaker or fuse blown	Be sure no one is working on cuber and reset breaker. If it trips shortly after reset, call a serviceman.
	Cuber's toggle switch in OFF position	Place in ICE position.
	Cuber off on high pressure cut-out control	Check condenser water supply, be sure all valves are open. Push reset button on control box to restart. If the water supply is o.k. but control continues to trip off, call a serviceman.
Cuber runs but doesn't produce ice	Bin switches are in open position	Make sure water curtains swing freely. Check bin switch adjustment. Refer to Figure 2.
	Insufficient water	Check main water valves and clean water strainer. Check float valve for proper operation.
	Water pump not operating	Check pump service cord. Is it fully plugged in? If pump still doesn't run, call serviceman.
Cuber is cycling on and off intermittently	Toggle switch in WATER PUMP position.	Place toggle switch in ICE position.
	Has a dirty air condenser	See "Condenser Cleaning Instructions."
	Air circulation is blocked or location not allowing any air exchange	Must have minimum 5" clearance around cuber and the cuber should be in a location that can handle the heat load.
Low ice capacity	High ambient or too low ambient temperatures	See "Location" — Page 2.
	Dirty or blocked condenser air flow.	Clean condenser and maintain 5" clearance around louvered areas. See "Cleaning Instructions."
	Water flowing from overflow elbow during freeze cycle.	Float valve not shutting off. Readjust per "Operational Procedure" No. 2, or replace.
	Dirty water system	Clean complete water system. See "Cleaning Instructions."
	Ice bridging set too thick	Readjust bridging per "Operational Procedure" No. 6.
Cubes not releasing and dropping into bin	Cube plate is dirty	Clean per instructions.
	Bridging is set too thin	Readjust bridging per "Operational Procedure No. 6."

# Ice Machine and Bin Warranty

From the date of original installation, we do hereby warrant each new Ice Machine and Bin to be free from defects in material and workmanship, under normal use and service, for a period of one year, and four additional years on the hermetic motor compressor in the Ice Machine.

Our obligation under this warranty is limited solely to correcting or replacing without charge at the factory in Manitowoc, Wisconsin any part or parts of this equipment which shall have been returned, transportation prepaid, and which our examination discloses to our satisfaction to be defective.

This warranty does not apply to any equipment that has been damaged by flood, fire, or suffered abuse, misuse, neglect or accident, or to any Ice Machine which has been altered so as to affect performance or reliability, except where such alteration has been accomplished with our prior written consent.

We further limit this warranty in that we shall not be held liable under this contract for any special, indirect, or consequential damages whatsoever resulting from any defect in material and workmanship which interferes with the normal use and service of such Ice Machine and Bin.

This warranty is a complete and exclusive statement of all terms of the agreement between the Manitowoc Equipment Works and the owner of the equipment, and all representations of the parties. This agreement shall not be varied, supplemented, qualified or interpreted by any prior course of dealing between the parties or by any usage of the trade.

Sales are made on the express understanding that there are no express or implied warranties other than the express warranty herein contained and that there are no implied warranties that the goods shall be merchantable or fit for a particular purpose other than the expressed one year and five year warranty set forth above.

To validate this warranty, the registration card must be signed on the date of installation and mailed promptly to the Manitowoc Equipment Works, Manitowoc, Wisconsin.

DEALER \_\_\_\_\_  
\_\_\_\_\_  
\_\_\_\_\_

INSTALLATION DATE \_\_\_\_\_



Division of The Manitowoc Company, Inc.  
2110 S. 26th St., P.O. Box 707, Manitowoc, WI 54220-0707