



Manitowoc[®] ICE MACHINES

SERIES

B320

B420

Installation Instructions

KEEP THESE INSTRUCTIONS WITH THE OWNER/OPERATOR USE AND CARE GUIDE FOR
FUTURE REFERENCE

SAFETY PRECAUTIONS

The ice machine must be installed according to these Installation Instructions.

Water service, drains, and electrical service connections must comply with applicable local and state codes.

Disconnect electrical service before servicing.

Read and understand all instructions before placing the ice machine into service.

GENERAL

These instructions are provided to assist the qualified installer. Check your local yellow pages for the name of the nearest Manitowoc Ice Machine Distributor, or call Manitowoc Equipment Works for information regarding installation and start-up services.

TABLE OF CONTENTS

Dimensions	3
Freight Damage Claims Procedures	4
Location of Ice Machine	4
Ice Machine Heat of Rejection	5
Leveling Ice Storage Bin	5
Electrical Service	6
Water Service/Drains	8
Cooling Tower Applications (Water Cooled Models)	9
Air-Cooled Air Baffle	10
Air-Cooled Condenser Filter	10
Installation Checklist	11
Before Starting Ice Machine	11
Automatic Cleaning System (AuCS™) Accessory . . .	11

Important

Failure to follow these installation guidelines may affect warranty coverage.



IMPORTANT

Proper installation is essential for maximum ice production and trouble-free operation of your Manitowoc Ice Machine.

Read and understand these Installation Instructions **before proceeding**. Installation corrections are not covered by the warranty.

If you encounter problems not covered by this guide, feel free to contact Manitowoc Equipment Works. We will be happy to provide whatever assistance you may need.

These Installation Instructions cover the following model numbers:

Self-Contained Air-Cooled	Self-Contained Water-Cooled
BR0320A	BR0321W
BD0322A	BD0323W
BY0324A	BY0325W
BR0420A	BR0421W
BD0423A	BD0423W
BY0424A	BY0425W

(For stainless steel exterior, add an "S" suffix to the model number – example: BY0424AS)

CONTACT YOUR MANITOWOC DEALER FOR THESE OPTIONAL ACCESSORIES:

BIN CASTER - Replaces standard legs.

DECORATOR FRONT COVER - Ebony black or ivory blend textured front panels for the machine (or dispensers) enhance style and beauty. (All models are also available with optional stainless steel cover and side exteriors.)

STACKING KITS - As your business grows and your ice needs increase, Manitowoc stack-on capability can double your daily ice production without using additional space.

ICE BAGGER - Maximize profits from bagged ice sales with this convenient accessory. This sturdy unit rests on the bin door frame, and adapts for left or right side filling.

TRI-LIMINATOR WATER FILTER SYSTEM - Engineered specifically for Manitowoc Ice Machines, Tri-Liminator water filters are an efficient, dependable, and affordable method of inhibiting scale formation, filtering sediment and removing chlorine taste and odor.

MANITOWOC CLEANER/SANITIZER - Manitowoc Ice Machine Cleaner and Sanitizer is available in convenient 16 oz. bottles. (The only approved cleaner and sanitizer compatible for use with Manitowoc products.)

DISPENSERS - Countertop dispensers are ideal for cafeterias and many types of self-service facilities. (Cold plate dispensers are also available.) Manitowoc auto-fill, floor-standing ice dispensers meet the strict sanitary requirements of the foodservice, lodging and healthcare industries.

AUTOMATIC CLEANING SYSTEM (AuCS™) ACCESSORY - This accessory virtually eliminates equipment cleaning maintenance expense. The AuCS™ accessory monitors ice making cycles and initiates self cleaning procedures automatically. (Refer to page 11 of these instructions.)

DIMENSIONS

ICE MACHINES

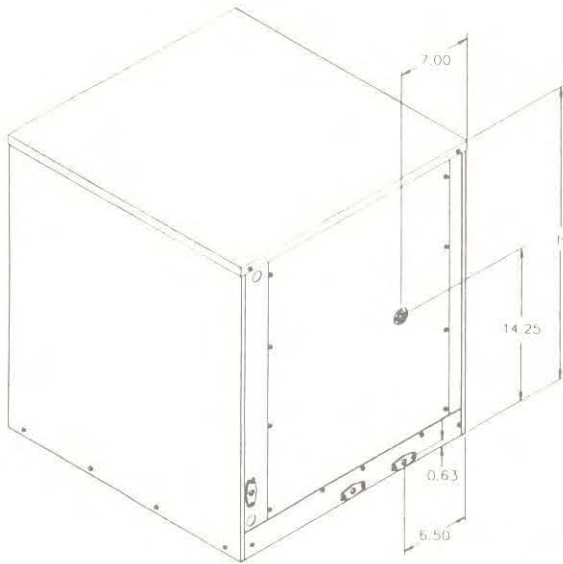

ICE MACHINE	DIMENSION H
B320	20"
B420	25"

SV1270

ICE STORAGE BINS

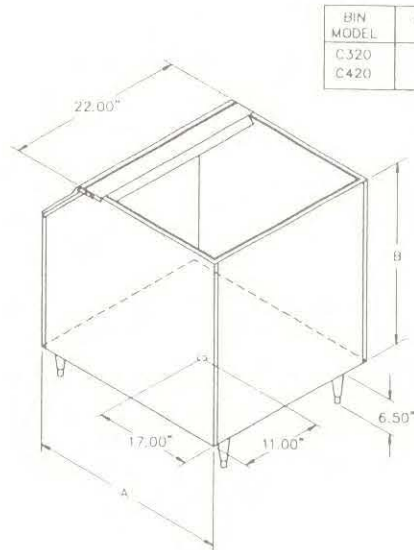

BIN MODEL	DIMENSION A	DIMENSION B
C320	34.00"	32.00"
C420	34.00"	44.00"

SV1272

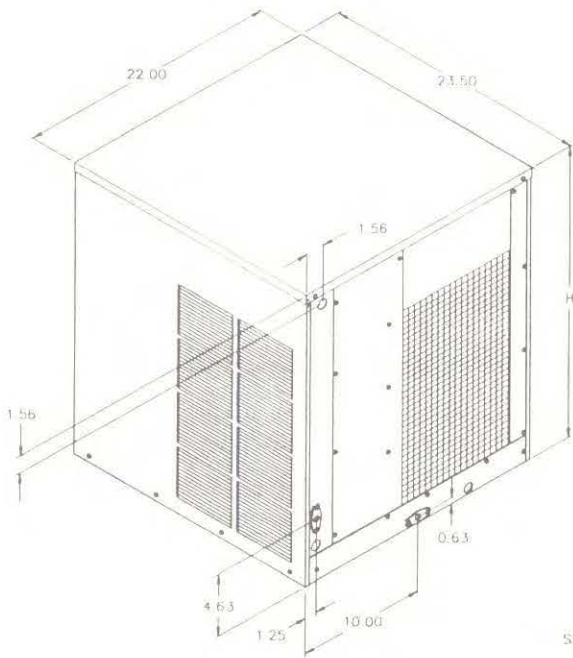

SV1271

FREIGHT DAMAGE AND CLAIMS PROCEDURES

1. **SHORTAGES**
Compare the number of cartons delivered to the quantity shown on your receipt. If the quantities do not match, have the driver make a note of the shortage and file a claim with the freight company.
2. **NO-FAULT FREIGHT CLAIM PROCEDURE**
Manitowoc assumes responsibility for all freight damage claims involving participating carriers, with the following exceptions:
 - a. When the trucking company loses the equipment.
 - b. When fire destroys the equipment en route.
 - c. When a traffic accident damages the shipment en route.
3. **VISIBLE DAMAGE**
 - a. If a carton appears to be damaged in any way, open the carton and inspect its contents in the presence of the driver.
 - b. To open the carton, cut the banding on the bottom only (in case the ice machine needs to be reboxed) and slide the carton up and off the ice machine.
 - c. Note the nature and extent of the damage on the freight bill.
 - d. Notify your local Manitowoc distributor. Request that they inspect the merchandise within 15 days of delivery. Do not attempt to repair the damage.
4. **CONCEALED DAMAGE**
 - a. If damage is not noticed until the time of installation, contact the distributor immediately and ask to have the equipment inspected.
 - b. Do not destroy packing materials until the inspection is completed.
 - c. These conditions must be met before your claim can be processed by the distributor.
5. **CLAIMS**
Manitowoc Equipment Works and the selling Distributor will arrange for repair or replacement of the equipment.

LOCATION OF ICE MACHINE

Air Temperature	
Minimum	Maximum
35°F (1.7°C)	110°F (43.3°C)

Caution

The ice machine must be protected if it will be subjected to temperatures below 32°F (0°C). Failure caused by exposure to freezing temperatures is not covered by the warranty. See REMOVAL FROM SERVICE/WINTERIZATION in the Owner/Operator Use and Care Guide.

Locate your machine away from heat-generating equipment and direct sunlight. Manitowoc ice machines operate most efficiently when:

- **LOCATED IN A CONTAMINANT-FREE AREA**

Air-cooled models are particularly vulnerable, and should be installed in an area that is free of airborne contaminants. An optional filter kit is available for self-contained air-cooled models. Refer to page 10.

- **HAVE PROPER CLEARANCE AT TOP, SIDES AND REAR**

Adequate airflow through and around the ice machine is essential for maximum ice production and long component life.

SELF-CONTAINED AIR-COOLED MODELS

- 8" minimum clearance on top and sides.
- 5" minimum clearance in rear.

WATER-COOLED AND REMOTE AIR-COOLED MODELS

There is no minimum clearance required, but 5" on the top, sides and rear is recommended for efficient operating and servicing.

ICE MACHINE HEAT OF REJECTION

Series Ice Machine	Heat of Rejection*	
	Air Conditioning**	Peak
B320	4,600	6,200
B420	7,000	9,600

*B.T.U./Hour

**Because the heat of rejection varies during the ice making cycle, the figure shown is an average.

Ice machines, like other refrigeration equipment, reject heat through the condenser. It is helpful to know the amount of heat rejected by the ice machine when sizing air conditioning equipment where self-contained air-cooled ice machines are installed. **This information is also necessary when evaluating the benefits of using water-cooled or remote condensers to reduce air conditioning loads.** The amount of heat added to an air conditioned environment by an ice machine using a water-cooled or a remote condenser is negligible. Knowing the amount of heat rejected is also important when sizing a cooling tower for a water-cooled condenser unit. The peak figure is used for sizing the cooling tower.

LEVELING ICE STORAGE BIN

1. Screw the leveling legs onto the bottom of the bin and screw the "foot" of each leg in as far as possible, Figure 1.
2. Move the bin into its final position.
3. Level the bin to assure that the bin door closes and seals properly. Turn the "foot" of the appropriate leg(s) to level the bin. Use a level on top of the bin when leveling the bin, Figure 1.

Note

An optional caster assembly is available in place of legs. Installation instructions are supplied with the casters.

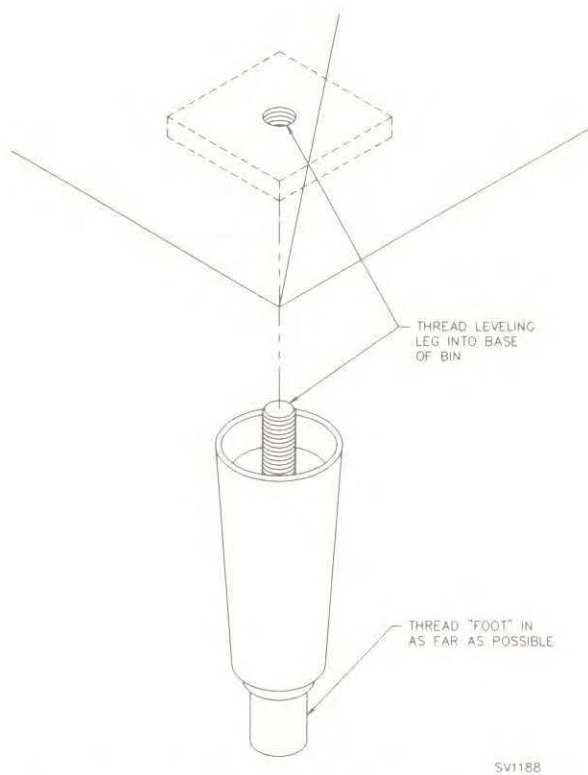

Figure 1. LEG INSTALLATION/LEVELING

ELECTRICAL SERVICE

⚠ Caution

All wiring must conform to local, state, and national codes.

Ice Machine	Voltage Phase Cycle	Air-Cooled		Water-Cooled	
		Maximum Fuse/Circuit Breaker	Minimum Circuit Ampacity	Maximum Fuse/Circuit Breaker	Minimum Circuit Ampacity
B320	115/1/60	15	11.2	15	10.3
	208-230/1/60	15	5.6	15	5.2
	*220-240/1/50	*15	5.7	*15	5.3
B420	115/1/60	20	13.1	20	12.3
	208-230/1/60	15	7.8	15	5.3
	*220-240/1/50	15	6.2	15	5.7
NUMBERS LISTED ARE AMPS					
*90°F Air / 70°F Water at 254 Volts					

VOLTAGE

The maximum allowable voltage variation is +/- 10% of the rated voltage at ice machine start-up (when the electrical load is highest.)

⚠ WARNING

The ice machine must be grounded in accordance with the National and Local Electrical Code.

FUSE/CIRCUIT BREAKER

A separate fuse/circuit breaker must be provided for each ice machine. Circuit breakers must be H.A.C.R. rated (this does not apply in Canada).

MINIMUM CIRCUIT AMPACITY

The minimum circuit ampacity is used to help select the wire size of the electrical supply. (Minimum circuit ampacity is not the ice machine's running amp load.) The wire size (or gauge) is also dependent upon location, materials used, length of run, etc., and therefore must be determined by a qualified electrician.

SELF-CONTAINED
ELECTRICAL CONNECTIONS

⚠ Caution

The diagrams are not intended to show proper wire routing, wire sizing, disconnects, etc., only the correct wire connections. All electrical connections and routing must conform to local and national codes.

SELF-CONTAINED ICE MACHINE

115/1/60
- OR -
208-230/1/60

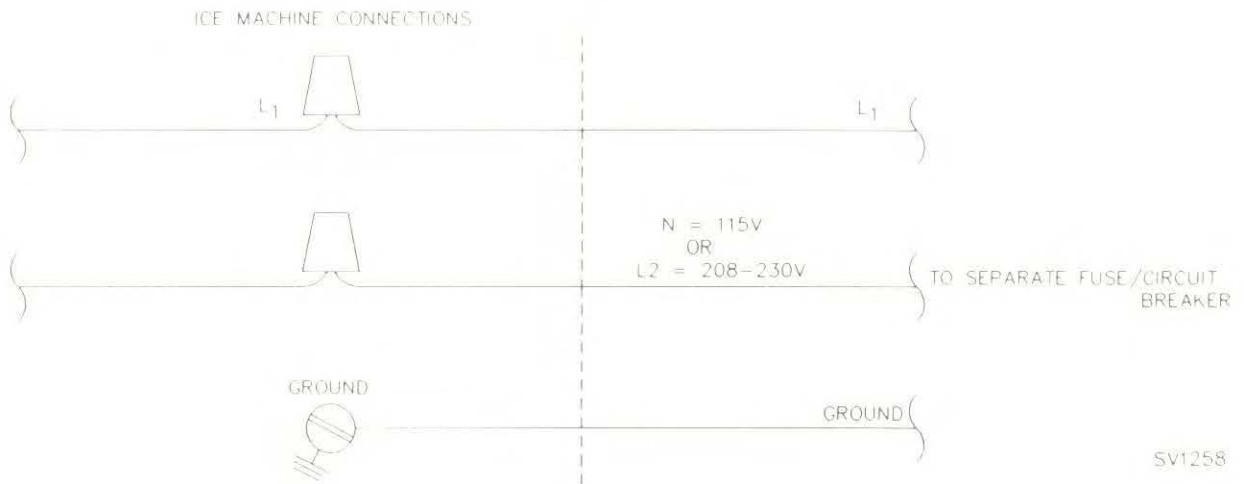

SELF-CONTAINED ICE MACHINE

220-240/1/50

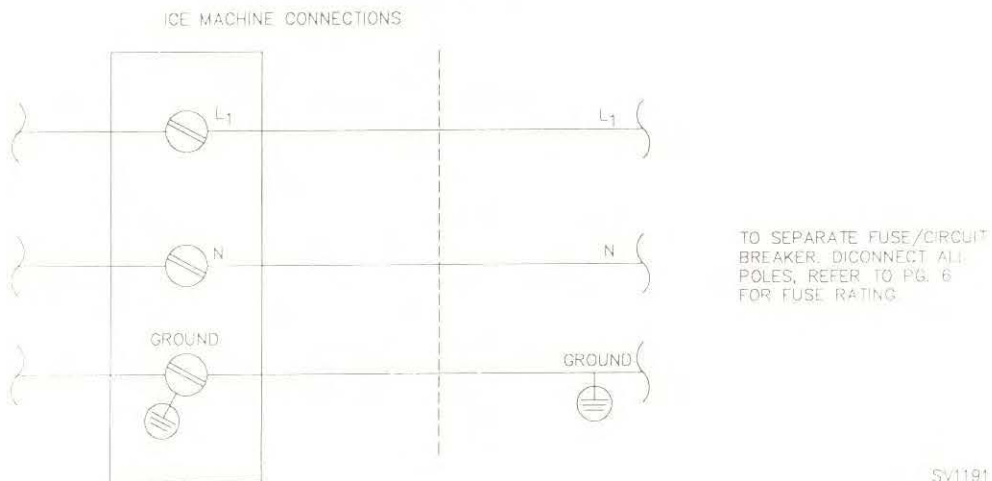

WATER SERVICE/DRAINS

⚠ Caution
Plumbing must conform to local and state codes.

Series Ice Machine B320 B420	Water Temperature	Water Pressure	Female Pipe Fitting (F.P.T.) Size	Tubing Size Up to Ice Machine Fitting
Ice Making Water Inlet	33°F (.6°C) min. 90°F (32.2°C) max.	20 psi min. 80 psi max.	3/8" F.P.T.	3/8"
Ice Making Water Drain	—	—	1/2" F.P.T.	1/2"
Condenser Water Inlet	33°F (.6°C) min. 90°F (32.2°C) max.	20 psi min. 150 psi max.	3/8" F.P.T.	1/2"
Condenser Water Drain	—	—	1/2" F.P.T.	1/2"
Bin Drain	—	—	3/4" F.P.T.	3/4"

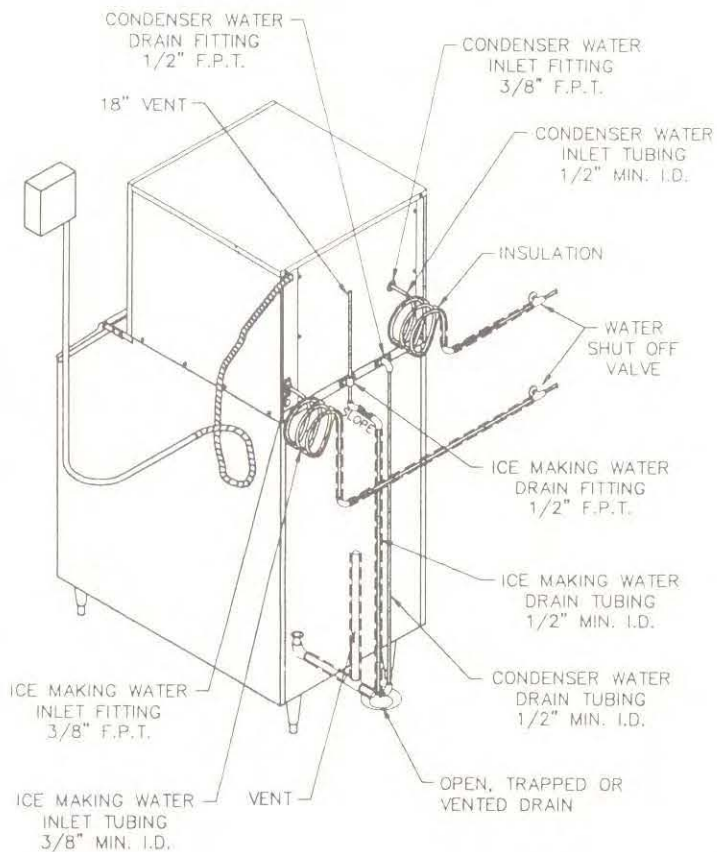

SV1273

Figure 3. TYPICAL WATER SUPPLY DRAIN INSTALLATION

WATER SUPPLY

Local water conditions may require treatment of the water to inhibit scale formation, filter sediment, and remove chlorine odors and taste.

Important

If you are installing a Manitowoc Tri-Liminator Water filter system, refer to the Installation Instructions supplied with the filter system for ice making water inlet connections.

Follow these guidelines to install water inlet lines:

- The ice machine must not be connected to a hot water supply. Be sure all hot water restrictors installed for other equipment are working. (Check valves on sink faucets, dishwashers, etc.)
- If water pressure exceeds the maximum recommended pressure, obtain a water pressure regulator from your Manitowoc Distributor.
- Install a shut-off valve for both the ice making and condenser water lines.
- Insulate water inlet lines to prevent condensation.

DRAIN CONNECTIONS

Follow these guidelines when installing drain lines to prevent drain water from flowing back into the ice machine and storage bin.

- Drain lines must have a 1-1/2 inch drop for each 5 feet of run, and must not create any traps.
- The floor drain must be large enough to accommodate drainage from all drains.
- Run separate bin and ice machine drain lines and insulate them to prevent condensation.
- The ice making water drain and bin drain must be vented to the atmosphere. Do not vent the condenser drain (on water-cooled models).

**COOLING TOWER APPLICATIONS
(Water-Cooled Models)**

A water-cooling tower installation does not require modification of the ice machine. The water regulator valve for the condenser continues to control the refrigeration discharge pressure. It is necessary to know the amount of heat rejection and the pressure drop through the condenser and the water valves (inlet and outlet of the ice machine) when using a cooling tower on an ice machine.

- Water entering the condenser must not exceed 90°F (32.2°C).
- Water flow through the condenser must not exceed 5 gallons per minute.
- Allow for a pressure drop of 7 psi between the condenser water inlet and outlet of the ice machine.
- Water exiting the condenser must not exceed 110°F (43.3°C).

AIR-COOLED AIR BAFFLE

The air baffle prevents condenser air from recirculating.

INSTALLATION INSTRUCTIONS (Figure 4)

1. Remove the two back panel screws next to the condenser.
2. Align the air baffle's mounting holes with the two screw holes and refasten the screws.

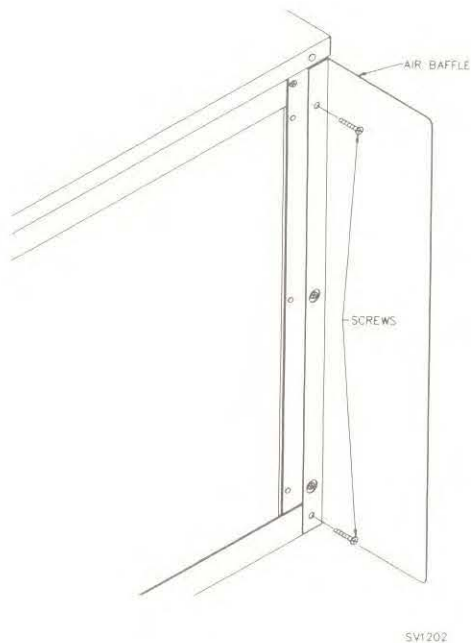

Figure 4. AIR BAFFLE INSTALLATION

AIR-COOLED CONDENSER FILTER

The filter is a washable aluminum type, designed to catch dust, lint, and grease.

INSTALLATION INSTRUCTIONS (Figure 5)

3. Remove the screw in the lower right corner on the back of the ice machine, and the screws on the left side of the air condenser, as illustrated below. **SAVE THE SCREWS.**

Note

The screw locations on the left side of the air condenser vary depending on the model.

4. Align the filter bracket holes with the corresponding holes on the back of the ice machine. Fasten the bracket to the ice machine with the screws you removed in step 1.
5. From the side or top of the ice machine, place the filter into the filter bracket. The filter is non-directional. It can be cleaned by using a mild soap and water solution.

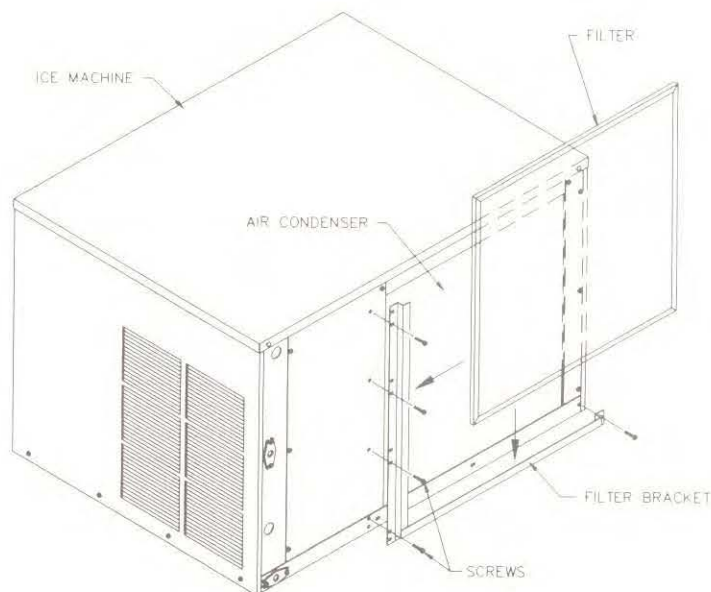

Figure 5. AIR-COOLED FILTER KIT INSTALLATION

INSTALLATION CHECKLIST

- Is the ice machine level?
- Has all the internal packing been removed?
- Have all the electrical and water connections been completed?
- Has the supply voltage been tested and checked against the rating on the nameplate?
- Is there correct clearance around the ice machine for proper air circulation?
- Has the air baffle been installed on air-cooled models?
- Is the ice machine installed where ambient temperature will not vary below 35°F (1.7°C) or above 110°F (43.3°C)? Incoming water temperature range 33°F (.6°C)/90°F (32.2°C)? (See Owner/Operator Use and Care Guide for winterizing.)
- Is there a separate drain for the water-cooled condenser?
- Are the ice machine and bin drains vented?
- Are all electrical leads free from contact with refrigeration lines and moving components?
- Has the owner/operator been instructed regarding maintenance procedures and the use of Manitowoc Cleaner and Sanitizer?
- Has the owner/operator completed the warranty registration card?
- Has the Owner/Operator Use and Care Guide been left with the owner/operator?
- Has the bin and ice machine been sanitized?

BEFORE STARTING ICE MACHINE

All Manitowoc Ice Machines are factory operated and adjusted before shipment. Normally, new installations do not require any adjustment.

To ensure proper operation, follow the OPERATIONAL CHECKS in the Owner/Operator Use and Care Guide.

Starting the ice machine and completing OPERATIONAL CHECKS is the responsibility of the owner/operator. Adjustments and maintenance outlined in the Owner/Operator Use and Care Guide are not covered by warranty.

AUTOMATIC CLEANING SYSTEM (AuCS™) ACCESSORY

This optional accessory monitors ice making cycles and initiates self cleaning procedures automatically. The AuCS™ Accessory can be set to automatically clean or sanitize the ice machine every 2, 4 or 12 weeks. Refer to the AuCS™ Installation-Owner/Operator Use and Care Guide for details.

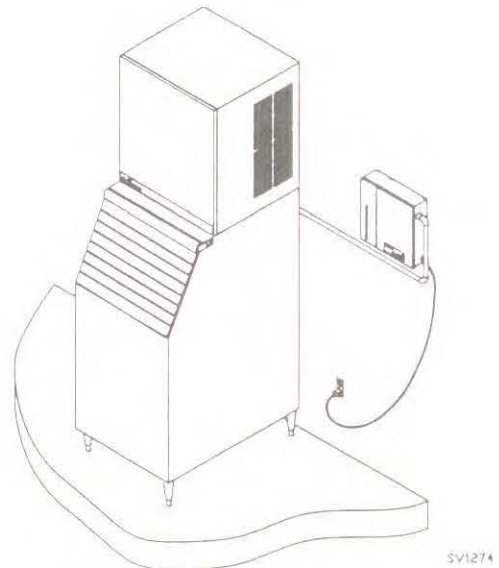

Figure 6. Automatic Cleaning System (AuCS™) Accessory