



Manitowoc® ICE MACHINES

SERIES

B1300

B1800

Installation Instructions

KEEP THESE INSTRUCTIONS WITH THE OWNER/OPERATOR
USE AND CARE GUIDE FOR FUTURE REFERENCE

SAFETY PRECAUTIONS

The ice machine must be installed according to these Installation Instructions.

Water service, drains, and electrical service connections must comply with applicable local and state codes.

Disconnect electrical service before servicing.

Read and understand all instructions before placing the ice machine into service.

GENERAL

These instructions are provided to assist the qualified installer. Check your local yellow pages for the name of the nearest Manitowoc Ice Machine Distributor, or call Manitowoc Equipment Works for information regarding installation and start-up services.

Important

Failure to follow these installation instructions may affect warranty coverage.

TABLE OF CONTENTS

Dimensions	3
Freight Damage Claims Procedure	4
Location of Ice Machine	4
Mounting Two Ice Machines on	
Single Storage Bin	4
Ice Machine Heat of Rejection	5
Leveling Ice Storage Bin	5
Electrical Service	6
Water Service/Drains	9
Cooling Tower Applications	
(Water-Cooled Models)	10
Ice Deflectors	10
Air-Cooled Air Baffles	11
Air-Cooled Condenser Filter	11
Remote Condenser/Line Set Installation	12
Routing of Line Sets	12
Remote Condenser Maximum Location	
Distances	13
Receiver Service Valve	14
Installation Checklist	16
Before Starting Ice Machine	16
Automatic Cleaning System (AuCS™)	
Accessory	16



IMPORTANT

Proper installation is essential for maximum ice production and trouble-free operation of your Manitowoc Ice Machine.

Read and understand these installation instructions **before proceeding**. Installation corrections are not covered by the warranty.

If you encounter problems not covered by this guide, feel free to contact Manitowoc Equipment Works. We will be happy to provide whatever assistance you may need.

Your Use and Care Guide covers the following model numbers:

Self-Contained Air-Cooled	Self-Contained Water-Cooled	Remote Air-Cooled
BR1300A	BR1301W	BR1390N
BD1302A	BD1303W	BD1392N
BY1304A	BY1305W	BY1394N
BR1800A	BR1801W	BR1890N
BD1802A	BD1803W	BD1892N
BY1804A	BY1805W	BY1894N

(For a stainless steel exterior, add an "S" suffix to the model number – example: BY1304AS)

CONTACT YOUR MANITOWOC DEALER FOR THESE OPTIONAL ACCESSORIES:

BIN CASTER - Replaces standard legs.

STACKING KITS - As your business grows and your ice needs increase, Manitowoc stack-on capability can double your daily ice production without using additional space.

ICE BAGGER - Maximize profits from bagged ice sales with this convenient accessory. This sturdy unit rests on the bin door frame, and adapts for left or right side filling.

TRI-LIMINATOR WATER FILTER SYSTEM - Engineered specifically for Manitowoc Ice Machines, Tri-Liminator water filters are an efficient, dependable, and affordable method of inhibiting scale formation, filtering sediment and removing chlorine taste and odor.

MANITOWOC CLEANER/SANITIZER - Manitowoc Ice Machine Cleaner and Sanitizer is available in convenient 16 oz. bottles. (The only approved cleaner and sanitizer compatible for use with Manitowoc products.)

DISPENSERS - Countertop dispensers are ideal for cafeterias and many types of self-service facilities. (Cold plate dispensers also available.) Manitowoc auto-fill floor-standing ice dispensers meet the strict sanitary requirements of foodservice, lodging and healthcare industries.

AUTOMATIC CLEANING SYSTEM (AuCS™) ACCESSORY - This accessory virtually eliminates equipment cleaning maintenance expense. The AuCS™ accessory monitors ice making cycles and initiates self cleaning procedures automatically. (Refer to page 16 of these instructions.)

DIMENSIONS

ICE MACHINES

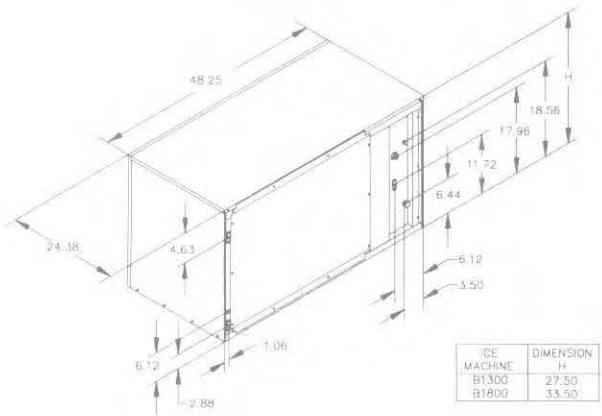

SV1298

SINGLE CIRCUIT REMOTE CONDENSER

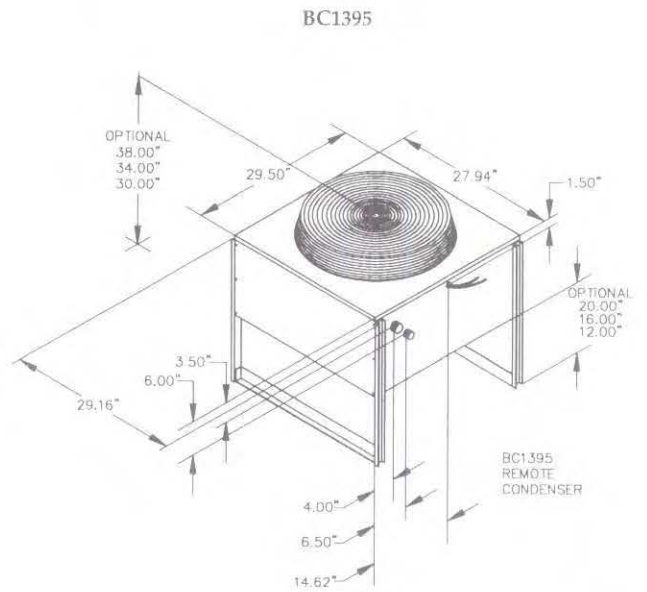

SV1297

ICE STORAGE BINS

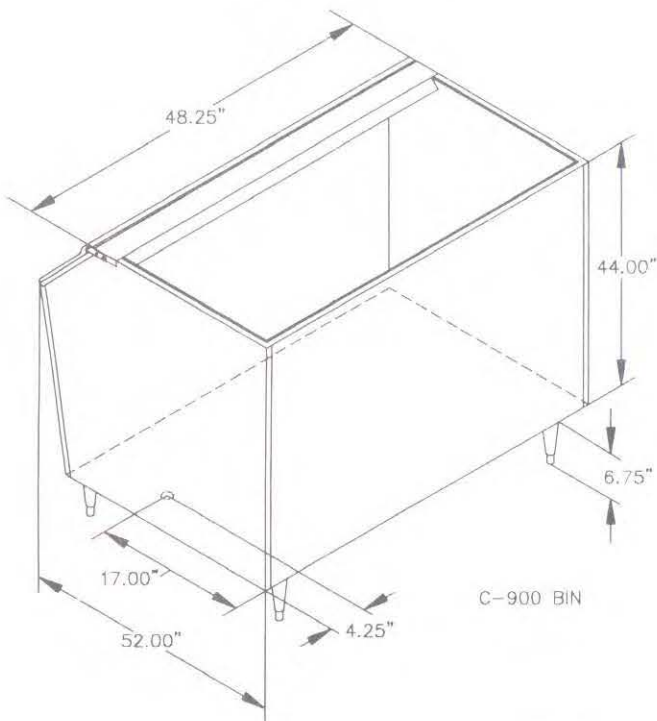

SV1296

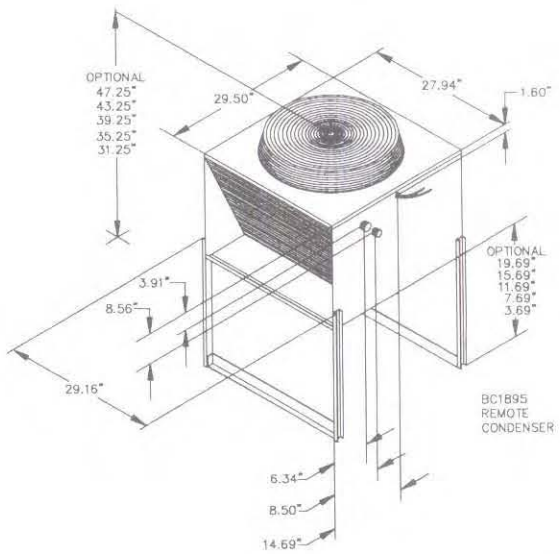

SV1301

FREIGHT DAMAGE AND CLAIMS PROCEDURES

1. **SHORTAGES**
Compare the number of cartons delivered with the quantity shown on your receipt. If the quantities do not match, have the driver make a note of the shortage and file a claim with the freight company.
2. **NO-FAULT FREIGHT CLAIM PROCEDURE**
Manitowoc assumes responsibility for all freight damage claims involving participating carriers with the following exceptions:
 - a. When the trucking company loses the equipment.
 - b. When fire destroys the equipment en route.
 - c. When a traffic accident damages the shipment en route.
3. **VISIBLE DAMAGE**
 - a. If a carton appears to be damaged in any way, open the carton and inspect its contents in the presence of the driver.
 - b. To open the carton, cut the banding on the bottom only (in case the ice machine needs to be reboxed), and slide the carton up and off the ice machine.
 - c. Note the nature and extent of the damage on the freight bill.
 - d. Notify your local Manitowoc distributor. Request that they inspect the merchandise within 15 days of delivery. Do not attempt to repair the damage.
4. **CONCEALED DAMAGE**
 - a. If damage is not noticed until the time of installation, contact the distributor immediately and ask to have the equipment inspected.
 - b. Do not destroy the packing materials until the inspection is completed.
 - c. These conditions must be met before your claim can be processed by the distributor.
5. **CLAIMS**
Manitowoc Equipment Works and the selling Distributor will arrange for repair or replacement of the equipment.

LOCATION OF ICE MACHINE

Air Temperature	
Minimum	Maximum
35°F (1.7°C)	110°F (43.3°C)

⚠ Caution

The ice machine must be protected if it will be subjected to temperatures below 32°F (0°C). Failure caused by exposure to freezing temperatures is not covered by the warranty. See REMOVAL FROM SERVICE/WINTERIZATION in the Owner/Operator Use and Care Guide.

Locate your machine away from heat generating equipment and direct sunlight. Manitowoc ice machines operate most efficiently when:

- **LOCATED IN A CONTAMINANT-FREE AREA**

Air-cooled models are particularly vulnerable, and should be installed in an area that is free of airborne contaminants.
- **HAVE PROPER CLEARANCE AT TOP, SIDES AND REAR**

Adequate air flow through and around the ice machine is essential for maximum ice production and long component part life.

SELF-CONTAINED AIR-COOLED MODELS
– 12" minimum clearance on the sides and the top.
– 8" minimum clearance in the back.

WATER-COOLED AND REMOTE AIR-COOLED MODELS
There is no minimum clearance required, but 5" on the top, sides and rear is recommended for efficient operating and servicing.

MOUNTING TWO ICE MACHINES ON SINGLE STORAGE BIN

A stacking kit is required for stacking two ice machines. Installation instructions are supplied with the stacking kit.

ICE MACHINE HEAT OF REJECTION

Series Ice Machine	Heat of Rejection*	
	Air Conditioning**	Peak
B1300	24,000	35,500
B1800	31,000	45,000

*B.T.U./Hour

**Because the heat of rejection varies during the ice making cycle, the figure shown is an average.

Ice machines, like other refrigeration equipment, reject heat through the condenser. It is helpful to know the amount of heat rejected by the ice machine when sizing air conditioning equipment where self-contained air-cooled ice machines are installed. **This information is also necessary when evaluating the benefits of using water-cooled or remote condensers to reduce air conditioning loads.** The amount of heat added to an air conditioned environment by an ice machine using water-cooled or remote condenser is negligible. Knowing the amount of heat rejected is also important when sizing a cooling tower for a water-cooled condenser unit. The peak figure is used for sizing the cooling tower.

LEVELING ICE STORAGE BIN

1. Screw the leveling legs onto the bottom of the bin and screw the "foot" of each leg in as far as possible, Figure 1.
2. Move the bin into its final position.
3. Level the bin to assure that the bin door closes and seals properly. Turn the "foot" of the appropriate leg(s) to level the bin. Use a level on top of the bin when leveling the bin, Figure 1.

Note

An optional caster assembly is available in place of legs. Installation instructions are supplied with the casters.

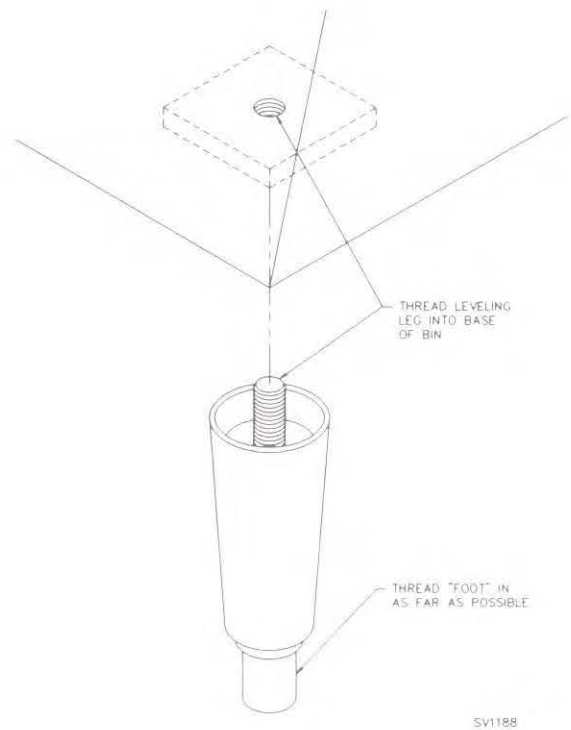



Figure 1. LEG INSTALLATION/LEVELING

ELECTRICAL SERVICE

 **Caution**

All wiring must conform to local, state, and national codes.

Ice Machine	Voltage Phase Cycle	Air-Cooled		Water-Cooled		Remote	
		Maximum Fuse/Circuit Breaker	Minimum Circuit Ampacity	Maximum Fuse/Circuit Breaker	Minimum Circuit Ampacity	Maximum Fuse/Circuit Breaker	Minimum Circuit Ampacity
B1300	208-230/1/60	30	19.1	30	17.8	30	19.1
	208-230/3/60	20	12.6	20	11.3	20	12.2
	220-240/1/50	30	20.5	30	19.2	30	21.6
	380-415/3/50	N/A	N/A	N/A	N/A	15	8.6
B1800	208-230/1/60	40	28.4	40	26.8	40	28.1
	208-230/3/60	30	19.6	30	17.9	30	19.3
	220-240/1/50	40	24.5	40	22.6	40	23.2
	380-415/3/50	N/A	N/A	N/A	N/A	15	9.7

NUMBERS LISTED ARE AMPS

VOLTAGE

The maximum allowable voltage variation is +/- 10% of the rated voltage at ice machine start-up (when the electrical load is highest.)

FUSE/CIRCUIT BREAKER

A separate fuse/circuit breaker must be provided for each ice machine. Circuit breakers must be H.A.C.R. rated (this does not apply in Canada).

 **WARNING**

The ice machine must be grounded in accordance with the National and Local Electrical Code.

MINIMUM CIRCUIT AMPACITY

The minimum circuit ampacity is used to help select the wire size of the electrical supply. (Minimum ampacity is not the ice machine's running amp load.) The wire size (or gauge) is also dependent upon location, materials used, length of run, etc., and therefore must be determined by a qualified electrician.

SELF-CONTAINED ELECTRICAL CONNECTIONS

⚠ Caution

The diagrams are not intended to show proper wire routing, wire sizing, disconnects, etc., only the correct wire connections. All electrical connections and routing must conform to local and national codes.

SELF-CONTAINED ICE MACHINE
208-230/1/60

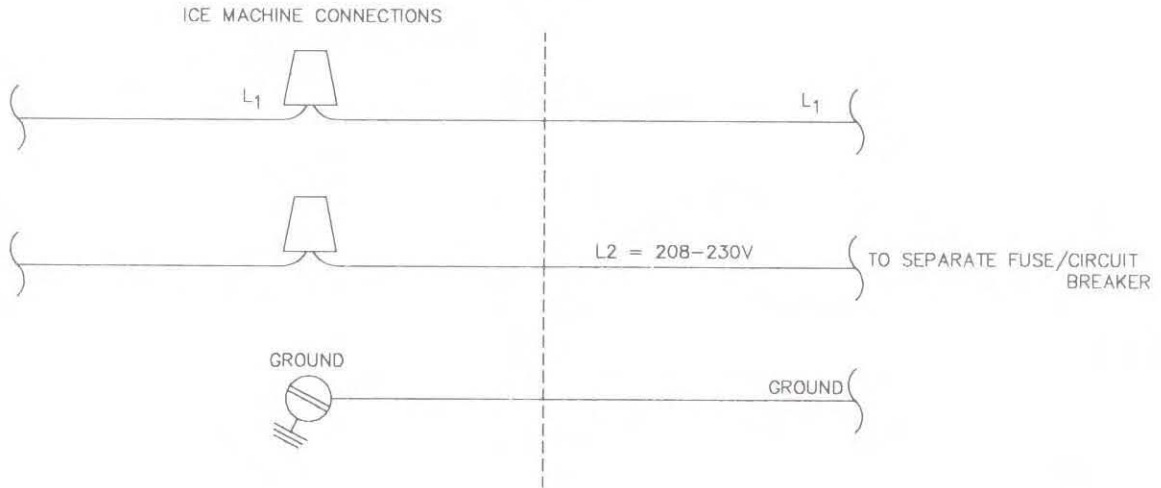

SV1302

SELF-CONTAINED ICE MACHINE
208-230/3/60

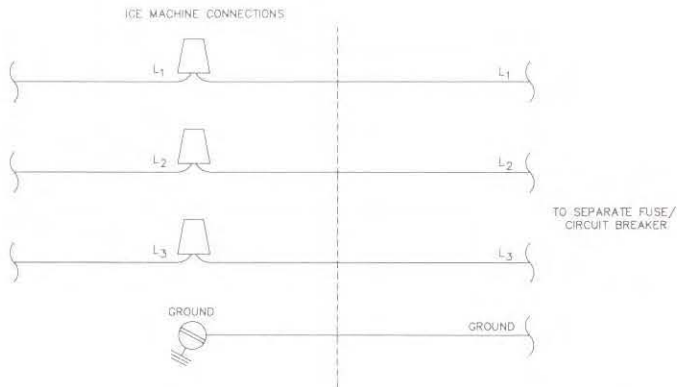

SV1190

SELF-CONTAINED ICE MACHINE
220-240/1/50

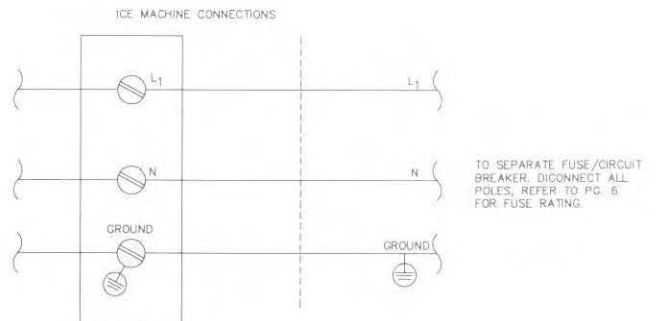

SV1191

REMOTE ELECTRICAL CONNECTIONS

Caution

The diagrams are not intended to show proper wire routing, wire sizing, disconnects, etc., only the proper wire connections. All electrical connections and routing must conform to local and national codes.

The single circuit condenser should be wired directly to the ice machine's electrical panel. The condenser fan runs only when the ice machine is operating.

REMOTE ICE MACHINE

208-230/1/60

With single circuit model condenser

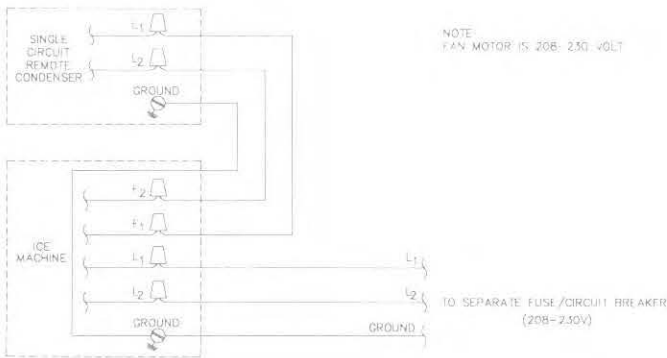

SV1303

REMOTE ICE MACHINE

208-230/3/60

With single circuit model condenser

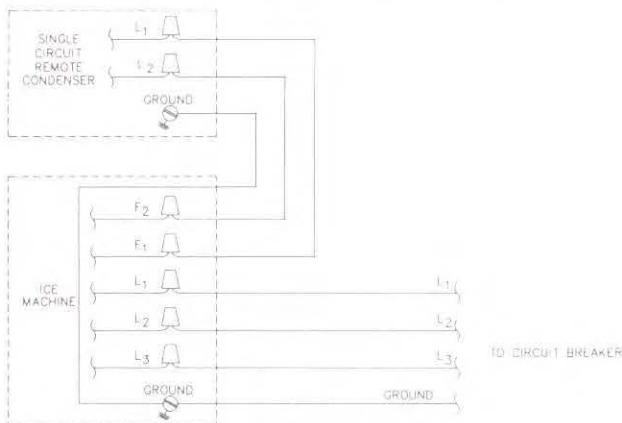

SV1199

REMOTE ICE MACHINE

220-240/1/50

With single circuit model condenser

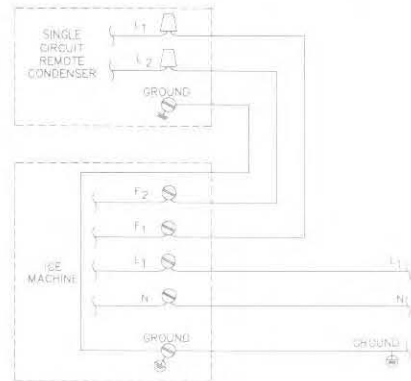

NOTE:
FAN MOTOR IS 220-240 VOLT

TO SEPARATE FUSE/CIRCUIT BREAKER (220-240), DISCONNECT ALL POLES, REFER TO PG. 6 FOR FUSE RATING.

SV1256

WATER SERVICE/DRAINS

⚠ Caution
 Plumbing must conform to local and state codes.

Series Ice Machine B1300/B1800	Water Temperature	Water Pressure	Female Pipe Fitting (F.P.T.) Size	Tubing Size Up to Ice Machine Fitting
Ice Making Water Inlet	33°F (.6°C) min. 90°F (32.2°C) max.	20 psi min. 80 psi max.	3/8" F.P.T.	3/8"
Ice Making Water Drain	—	—	1/2" F.P.T.	1/2"
Condenser Water Inlet	33° (.6°C) F min. 90°F(32.2°C) max.	20 psi min. 150 psi max.	1/2" F.P.T.	1/2"
Condenser Water Drain	—	—	1/2" F.P.T.	1/2"
Bin Drain	—	—	3/4" F.P.T.	3/4"

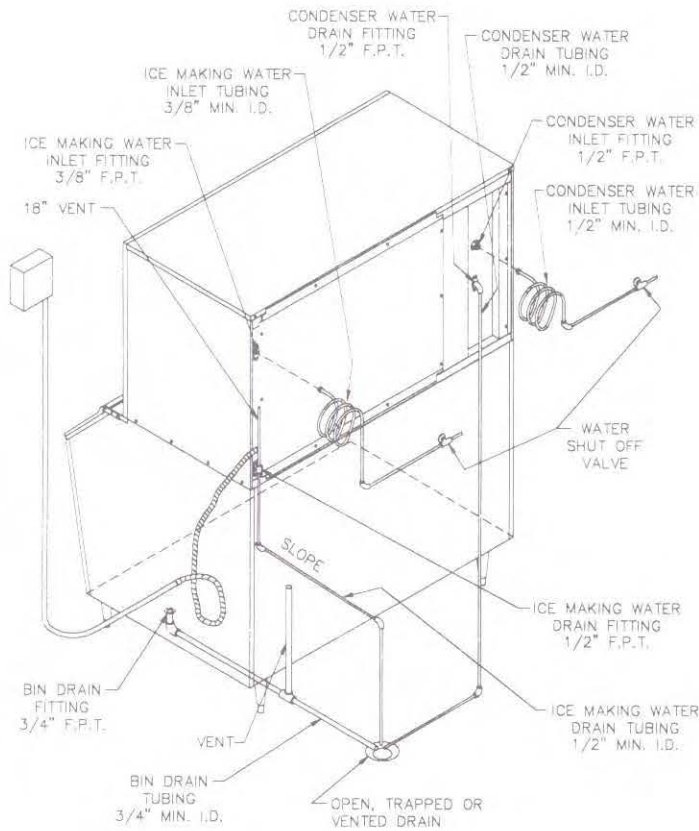

SV1304

Figure 3. TYPICAL WATER SUPPLY DRAIN INSTALLATION

WATER SUPPLY

Local water conditions may require treatment of the water to inhibit scale formation, filter sediment, and remove chlorine odors and taste.

Important

If you are installing a Manitowoc Tri-Liminator Water filter system, refer to the Installation Instructions supplied with the filter system for ice making water inlet connections.

Follow these guidelines to install water inlet lines:

- The ice machine must not be connected to a hot water supply. Be sure all hot water restrictors (check valves) installed for other equipment (sink faucets, dishwashers, etc.) are working.
- If water pressure exceeds the maximum recommended pressure, obtain a water pressure regulator from your Manitowoc Distributor.
- Install a shut-off valve for both the ice making and condenser water lines.
- Insulate water inlet lines to prevent condensation.

DRAIN CONNECTIONS

Follow these guidelines when installing drain lines to prevent the backflow of drain water into the ice machine and storage bin.

- Drain lines must have a 1-1/2 inch drop per 5 feet of run, and must not create any traps.
- The floor drain must be large enough to accommodate drainage from all drains.
- Run separate bin and ice machine drain lines and insulate them to prevent condensation.
- The ice making water drain and the bin drain must be vented to the atmosphere. Do not vent the condenser drain (water-cooled models).

**COOLING TOWER APPLICATIONS
(Water-Cooled Models)**

A water-cooling tower installation does not require modification of the ice machine. The water regulator valve for the condenser continues to control the refrigeration discharge pressure. It is necessary to know the amount of heat rejection and the pressure drop through the condenser and the water valves (inlet and outlet of the ice machine) when using a cooling tower on an ice machine.

- Water entering the condenser must not exceed 90°F (32.2°C).
- Water flow through the condenser must not exceed 5 gallons per minute.
- Allow for a pressure drop of 7 psi between the condenser water inlet and outlet of the ice machine.
- Water exiting the condenser must not exceed 110°F (43.3°C).

ICE DEFLECTORS

Installation Instructions (Figure 4)

1. Remove front cover.
2. Slide left and right ice deflectors onto metal partitions located in ice machine evaporator area.

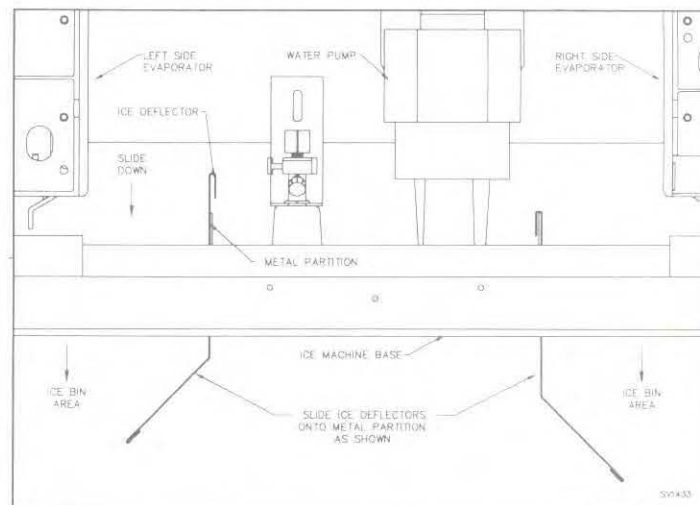

Figure 4. ICE DEFLECTOR INSTALLATION

AIR-COOLED AIR BAFFLES

The air baffles prevent condenser air from recirculating.

INSTALLATION INSTRUCTIONS (Figure 5)

1. Remove the two screws next to the condenser.
2. Align the air baffle's mounting holes and refasten the screws.

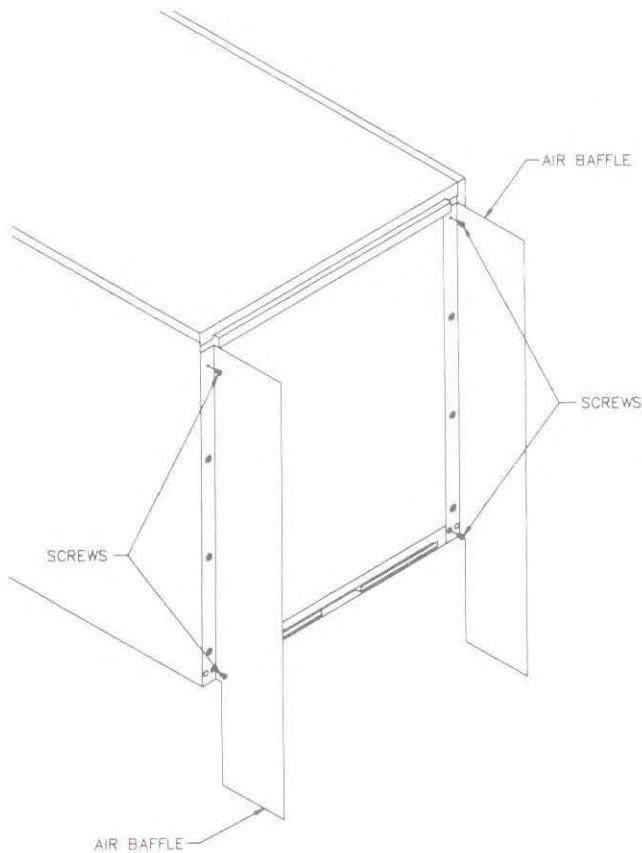

SV1305

Figure 5. AIR BAFFLE INSTALLATION

AIR-COOLED CONDENSER FILTER

The filter is a washable aluminum type, designed to catch dust, lint, and grease.

INSTALLATION INSTRUCTIONS (Figure 6)

The filter is factory-installed. The filter is non-directional and can be cleaned with a mild soap and water solution.

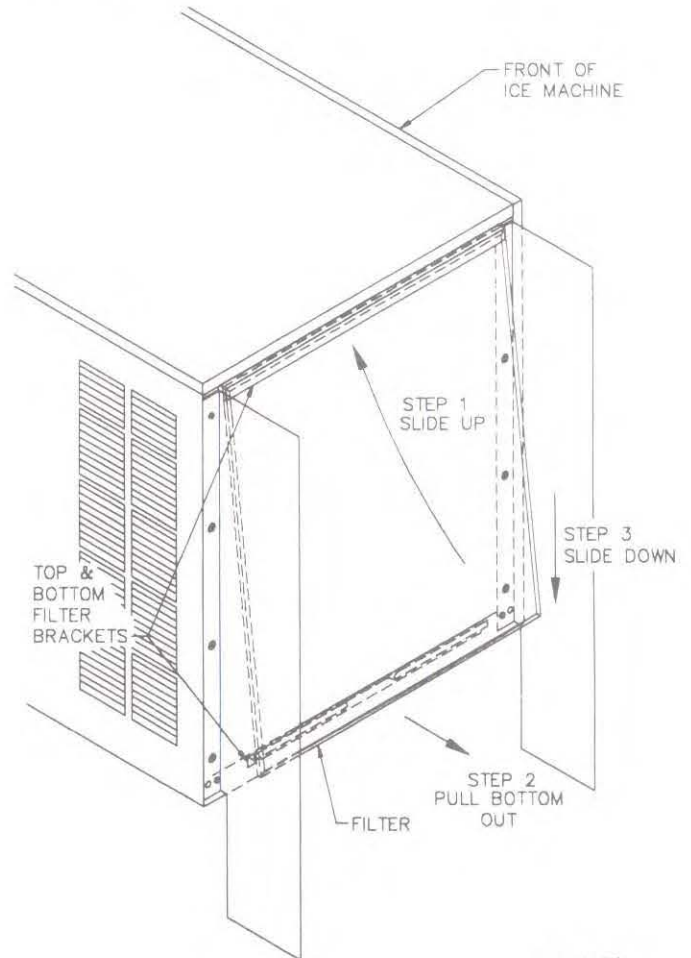

SV1299

Figure 6. AIR-COOLED FILTER KIT INSTALLATION

**REMOTE CONDENSER
MAXIMUM LOCATION DISTANCES**

PHYSICAL LINE SET LENGTH: 100 FT. MAXIMUM

The ice machine compressor must have the proper oil return. The receiver capacity is only designed to hold the nameplate charge. This is sufficient to operate the ice machine in ambient temperatures of -20°F (-28.9°C) to +130°F (54.4°C) with line set lengths up to 100 ft.

**LINE SET RISE: 35 FT. MAXIMUM
LINE SET DROP: 15 FT. MAXIMUM**

Line set rises, drops, or horizontal runs greater than the maximum distance allowed will exceed the compressor start-up and pumping design limits, and will result in poor oil return to the compressor.

**CALCULATED LINE SET DISTANCE:
150 FT. MAXIMUM**

To eliminate the combination of rises, drops, and horizontal runs exceeding the compressor start-up and pumping design limits, one of the following calculations must be made:

Step 1. Insert measured rise (R) into formula and multiply it by 1.7 to get a calculated rise.

Example: A condenser located above the ice machine 10 ft. has a 17 ft. calculated total. (10 ft. x 1.7 = 17 ft.)

Step 2. Insert measured drop (D) into formula and multiply by 6.6 to get a calculated drop.

Example: A condenser located below the ice machine 10 ft. has a 66 ft. calculated total (10 ft. x 6.6 = 66 ft.)

Step 3. Insert measured horizontal distance into formula. No calculation is necessary.

Step 4. Add the calculated rise, calculated drop, and horizontal distance together to get the total calculated distance. If 150 ft. total calculated distance is exceeded, the condenser must be moved to a new location which permits proper equipment operation.

Important

If a line set rise is followed by a line set drop, a second line set rise cannot be made.

-OR-

If a line set drop is followed by a line set rise, a second line set drop cannot be made.

MAXIMUM LINE SET DISTANCE FORMULA

- Step 1 Measured Rise (35 ft. maximum) _____ x 1.7 = _____ Calculated Rise
- Step 2 Measured Drop (15 ft. maximum) _____ x 6.6 = _____ Calculated Drop
- Step 3 Measured Horizontal Distance (100 ft. maximum) = _____ Horizontal Distance
- Step 4 Total Calculated Distance (150 ft. maximum) = _____ Total Calculated Distance

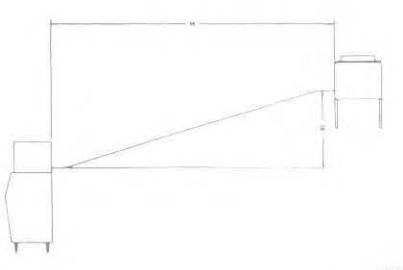

SV118

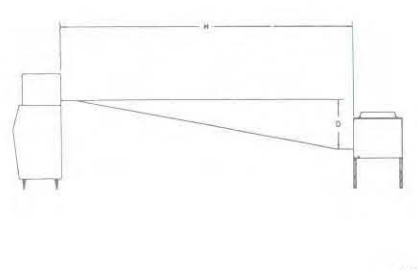

SV119

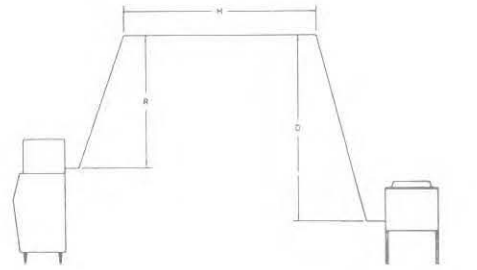

SV124

Combination of Rise(s) with Horizontal

Combination of Drop(s) with Horizontal

Combination of Rise and Drop with Horizontal

**REMOTE CONDENSER/
LINE SET INSTALLATION**

Ice Machine	Remote Single Circuit Condenser	Line* Set
B1300	BC1395	RL-20-HP81
		RL-35-HP81
B1800	BC1895	RL-50-HP81

*Line set size: Discharge 1/2"
Liquid 3/8"

Air temperature around the condenser	
Minimum	Maximum
-20°F (-28.9°C)	130°F(54.4°C)

Condensers must be mounted horizontally with the fan motor on top, Figure 9.

GENERAL

Remote condenser installations consist of vertical and horizontal line set distances between the machine and condenser. When combined, they must fit within approved guidelines. These guidelines, drawings, and calculation methods must be followed to verify a proper remote condenser installation.

WARRANTY NOTE

The sixty (60) month compressor warranty, including the thirty-six (36) month labor replacement warranty, will not apply when the remote ice machine is not installed according to specifications, or the refrigeration system is

modified with a condenser, heat reclaim device, or parts and assemblies other than those manufactured by Manitowoc Equipment Works, unless Manitowoc Equipment Works approves these modifications for specific locations in writing.

ROUTING OF LINE SETS (Figure 7)

Follow these guidelines when routing refrigerant lines. This will insure the proper performance and service accessibility to the ice machine. A 2-1/2" round hole in the wall or roof is needed for tubing routing.

Note

Line set end with 90° bend connects to ice machine. The straight end connects to the remote condenser.

1. Make the service loop in the line sets as shown. This permits easy access to the ice machine for cleaning and service. Hard rigid copper should not be used at this location.
2. Never form a trap in refrigeration lines. Refrigerant oil must always be free to drain toward the ice maker or the condenser. The trap formed by the service loop is part of the ice machine's design.
3. Refrigerant lines located outdoors should be kept as short as possible, and must be run to prevent traps.

Excess tubing must be routed in a **downward horizontal spiral** and supported to assure it does not collapse. Do not coil tubing vertically.

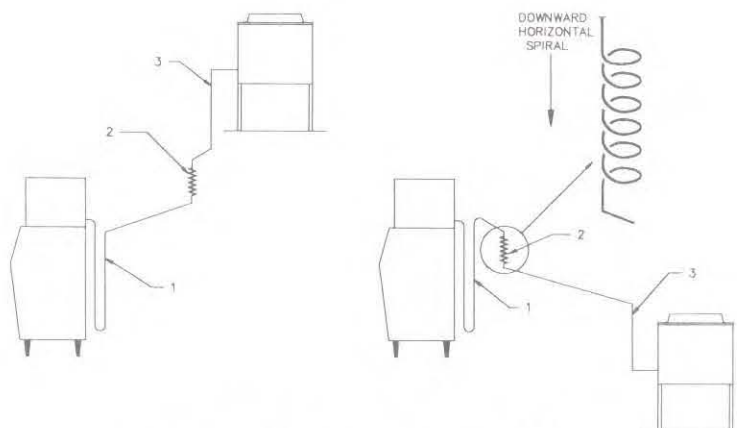

Figure 7. ROUTING OF LINE SETS

SV1204

LENGTHENING OR REDUCING LINE SET LENGTHS

In most cases, by routing the line set properly, shortening will not be necessary (refer to figure 7). When shortening or lengthening is required, do so before connecting the line set to the ice machine or the remote condenser. This prevents the loss of refrigerant in the ice machine or the condenser.

The quick connect fittings on the line sets are equipped with Schrader valves. Use these valves to recover any vapor charge from the line set. When lengthening or shortening lines, apply good refrigeration practices and insulate new tubing. Do not change the tube sizes. Evacuate the lines and place approximately 5 oz. of vapor refrigerant charge in each line.

CONNECTION OF LINE SET

1. Remove the dust caps from the line set, the condenser, and the ice machine.
2. Apply refrigeration oil to the threads on the quick disconnect couplers before connecting them to the condenser.
3. Carefully thread the female fitting to the condenser or ice machine by hand.
4. Using the proper size wrench, tighten the couplings until they bottom out. Turn an additional 1/4 turn to ensure proper brass-to-brass seating. (If a torque wrench is used: liquid line: 10-12 ft. lbs; discharge line: 35-45 ft. lbs.).
5. Check all fittings for leaks.

Caution

If it is necessary to remove the connecting couplers from the ice machine or remote condenser, remove all refrigerant from the ice machine before attempting to remove the couplers.

RECEIVER SERVICE VALVE (Figure 8)

The receiver service valve is closed during shipment. Open the valve prior to starting the ice machine.

1. Remove the top panel and the left side panel.
2. Remove the receiver service valve cap.
3. Backseat (open) the valve.
4. Reinstall the cap and panels.

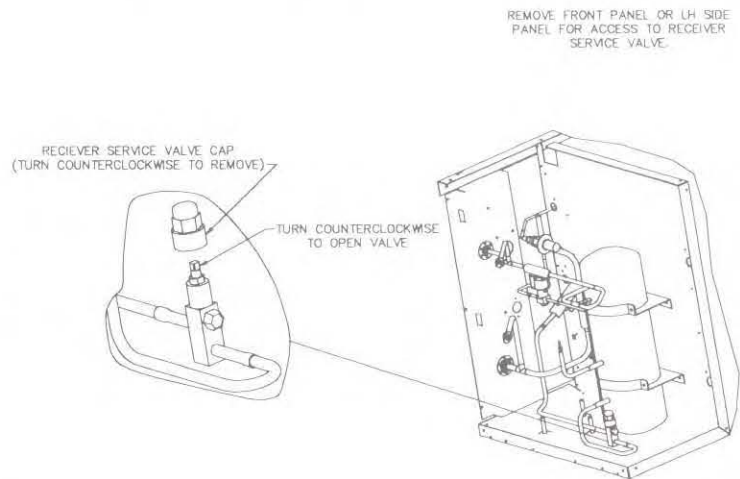
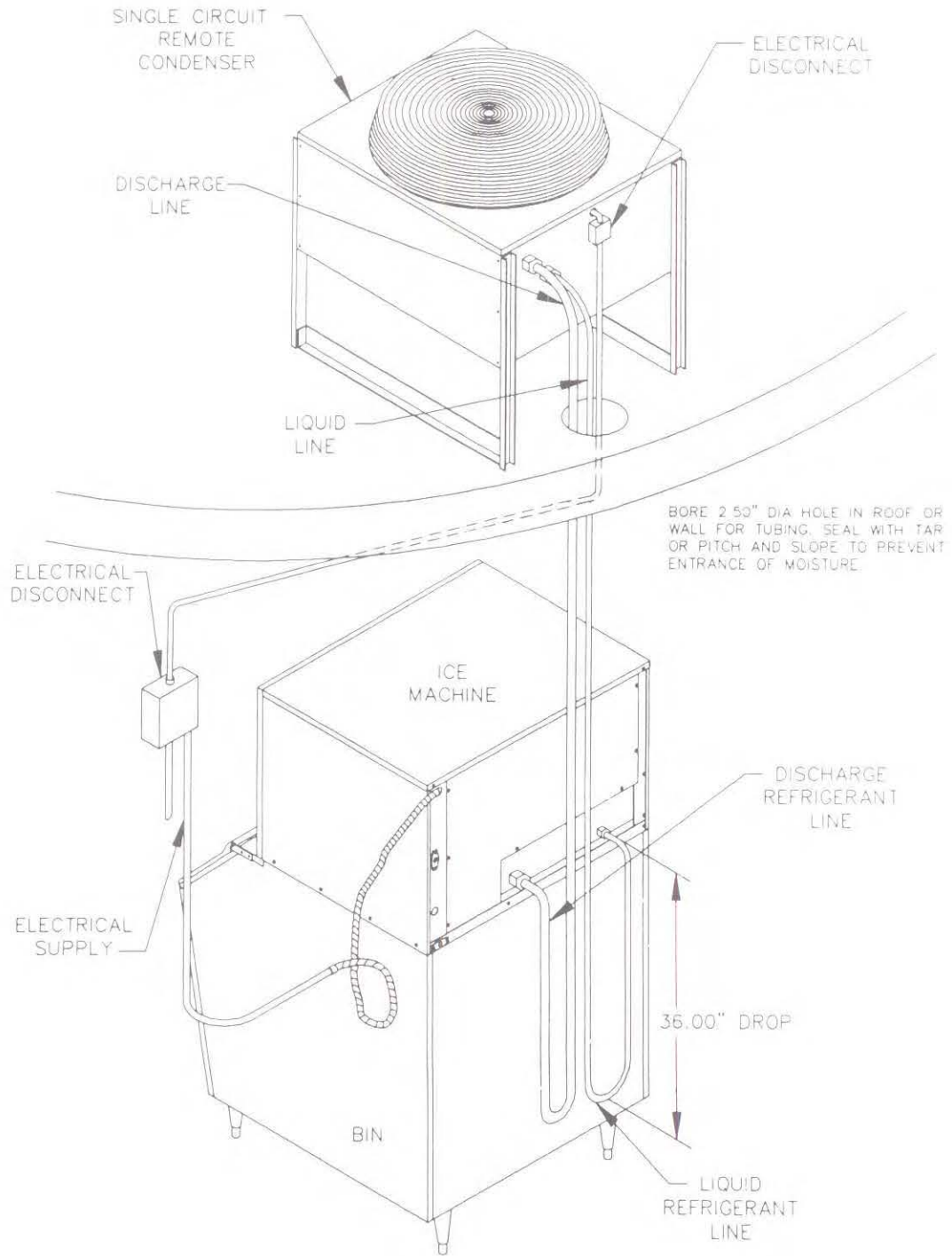

Figure 8. BACKSEATING RECEIVER SERVICE VALVE



SV1184

Figure 9. TYPICAL SINGLE CIRCUIT REMOTE CONDENSER INSTALLATION

INSTALLATION CHECKLIST

- Is the ice machine level?
- Has all the internal packing been removed?
- Have all the electrical and water connections been completed?
- Has the supply voltage been tested and checked against the rating on the nameplate?
- Is there a minimum of 5 inches clearance around the ice machine for proper air circulation?
- Has the air baffle been installed on air-cooled models?
- Is the ice machine installed where ambient temperatures will not vary below 35°F (1.7°C) or above 110°F (43.3°C)? Incoming water temperature range 33°F (.6°C)/90°F (32.2°C)? (See Owner/Operator Use and Care Guide for winterizing.)
- Is there a separate drain for the water-cooled condenser?
- Are the ice machine and bin drains vented?
- Are all electrical leads free from contact with refrigeration lines and moving components?
- Has the owner/operator been instructed regarding maintenance procedures and the use of Manitowoc Cleaner and Sanitizer?
- Has the owner/operator completed the warranty registration card?
- Has the Owner/Operator Use and Care Guide been left with the owner/operator?
- Has the bin and ice machine sanitized?

Additional Ice Machine Checks for REMOTE MODELS

- Has the receiver service valve been opened?
- Does the remote condenser fan operate properly? (After start-up.)
- Is the remote condenser located where ambient temperatures will not vary below -20°F (-28.9°C) or above +130°F (54.4°C)?

BEFORE STARTING ICE MACHINE

All Manitowoc Ice Machines are factory operated and adjusted before shipment. Normally, new installations do not require any adjustment.

To ensure proper operation, follow the the OPERATIONAL CHECKS in the Owner/Operator Use and Care Guide.

Starting the ice machine and completing the OPERATIONAL CHECKS is the responsibility of the Owner/Operator. Adjustments and maintenance procedures outlined in the Owner/Operator Use and Care Guide are not covered by warranty.

AUTOMATIC CLEANING SYSTEM (AuCS™) ACCESSORY

This optional accessory monitors ice making cycles and initiates self cleaning procedures automatically. The AuCS™ Accessory can be set to automatically clean or sanitize the ice machine every 2, 4 or 12 weeks. Refer to the AuCS™ Installation– Owner/Operator Use and Care Guide for details.

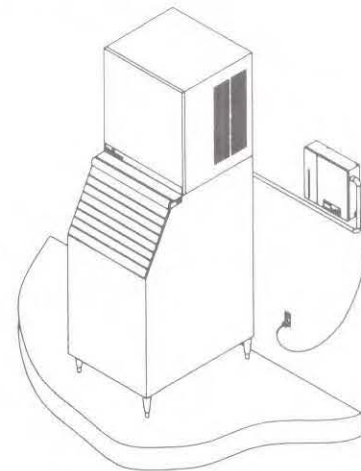

SV1274

Figure 10. Automatic Cleaning System (AuCS™) Accessory