

# Manitowoc

## AD & AR 1100 & 2200 SERIES ICE CUBER SERVICE MANUAL

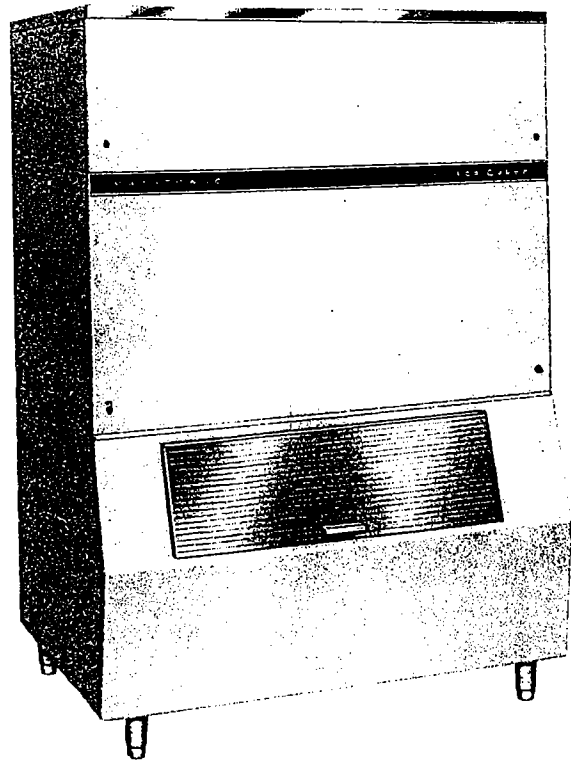
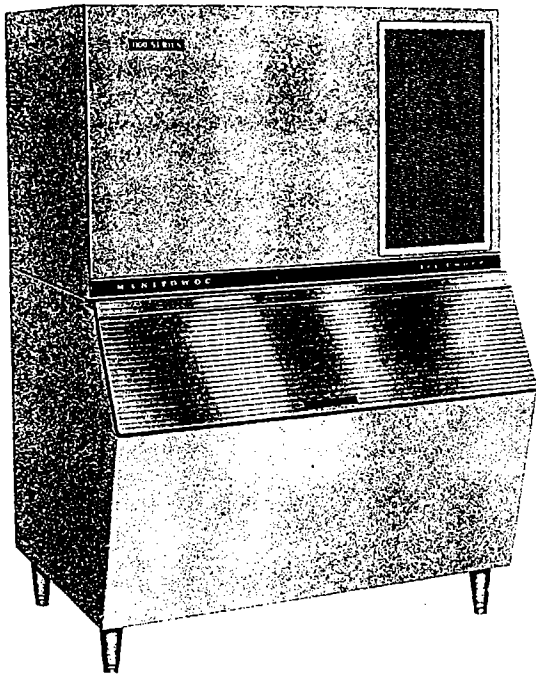

**Manitowoc** equipment works

A division of The Manitowoc Company, Inc.

500 South 16th Street, Manitowoc, Wisconsin 54220

80-0033-1

TABLE OF CONTENTS

Uncrating and Inspection .....	Page 2
Location .....	Page 2
Setting Up Cabinet .....	Page 2
Serial and Electrical Plate .....	Page 2
Removing Panels .....	Page 2
Electrical Connections .....	Page 2
General Requirements .....	Page 2
Connecting Power Supply .....	Page 2
Water Supply .....	Page 2
Connecting Water Supply .....	Page 2
Drain Connections .....	Page 2
Check List for Starting Machine .....	Page 2
Check for Following Things .....	Page 2
Installation Dimensions .....	Page 3
Start Up .....	Page 4
Ice Size Control .....	Page 4
Manitowoc Freeze and Harvest Control for 1100 Series Models AR and AD .....	Page 4
Controls .....	Page 4
High Pressure Cut Out .....	Page 4
Suction Line Thermo Disc .....	Page 4
Toggle Switch .....	Page 4
Ranco or Penn Pressure Control .....	Page 4
Paragon Time Clocks .....	Page 5
Damper Door Switch .....	Page 5
Setting Timer .....	Page 5
Figure 2 .....	Page 6
Figure 3 .....	Page 7
Figure 4 – Front Evaporator .....	Page 8
Figure 5 .....	Page 9
Figure 6 – Water Distribution Assembly .....	Page 10
Ice Production and Specifications .....	Page 11
1100 Wiring Diagram .....	Page 12
2200 Series .....	Page 13
Installation .....	Page 13
Electrical .....	Page 13
Water Connections .....	Page 13
Start Up .....	Page 13
Manitowoc A-2200 Series Head Section specifications .....	Page 14
Figure 7 – A-2200 Series Cuber (Water Cooled Only) .....	Page 15
Figure 8 – Refrigeration Cycle .....	Page 16
Service Analysis .....	Page 17
Specifications .....	Page 18
2200 Wiring Diagram .....	Page 19
Basic Parts List .....	Page 20
Service and Parts Procedure .....	Page 21
Warranty .....	Page 22

## FORWARD

Manitowoc Equipment Works, Division of the Manitowoc Company, Inc., Manitowoc, Wisconsin, presents this Service Manual to assist the service man with information concerning CONSTRUCTION, INSTALLATION, and MAINTENANCE of the MANITOWOC ICE MAKER.

The problems of the user and the service man have been given special emphasis in the development of the latest MANITOWOC Ice Machines.

If you encounter a problem which is not answered by this manual, please feel free to write or call the Service Department of the Manitowoc Equipment Works, Division of The Manitowoc Company, Inc., Manitowoc, Wisconsin, describing the problem you have encountered. The Service Department will be happy to give you particularized advice and assistance. Whenever calling or writing, please state the complete model and serial number of the ice making equipment.

MANITOWOC EQUIPMENT WORKS  
Div. of THE MANITOWOC CO., INC.  
Manitowoc, Wisconsin 54220

## MODELS

This manual includes the following models:

AR1100A and AR2200A – Regular Cube, Air Cooled  
AR1101W and AR2201W – Regular Cube, Water Cooled  
AD1102A and AD 2202A – Dice Cube, Air Cooled  
AD1103W and AD 2203W – Dice Cube, Water Cooled

### UNCRATING AND INSPECTION

All AR and AD 1100 Series ice cubers are shipped in corrugated cartons. To uncrate remove the staples around the lower edge of the carton, lift the carton upwards and off, and inspect for concealed damage. Machine section is held to the skid by four bolts. Remove these skid bolts and set the machine in place. When machine is in place carefully level cabinet.

### LOCATION

For maximum efficiency, pick a location away from sources of heat like radiators, ovens, other refrigeration condensing units, direct sunlight, etc. Provide space around the cabinet for air circulation. All models require a minimum of 18 inches at the back and top of the machine to provide room for service. Cabinets located in unheated areas must be protected from freezing or shut down and drained.

### SERIAL AND ELECTRICAL PLATE

The combined serial and electrical plate is located on the right side of the cabinet. Be sure to send the complete serial number (14 numbers) and the model number when calling for service or parts.

### REMOVING PANELS

To remove the front and back panels, remove the two screws from each side of the panel and pull the panel out and down.

To remove the top panel, remove the two screws at each end and lift the top off of machine.

### ELECTRICAL CONNECTIONS

208-230 Volt-60 Cycle-1 Phase. Max. fuse size (See Serial and Electrical Plate). Minimum wire size (See Serial and Electrical Plate Minimum ampacity rating)

### GENERAL REQUIREMENTS

All electrical and water supply and drain connections must conform to all local and national codes.

### CONNECTING POWER SUPPLY

Your cuber should be connected to a separately fused circuit. Fuse size must not exceed maximum fuse size shown on the electrical plate.

All electrical wiring connected to your cuber must be rated equal to the minimum circuit ampacity shown on the electrical plate.

From right side of cuber place separately fused wire through the electrical supply hole (Fig. 1A). Connect the wires to the lead wires in the junction box (Fig. 2A).

### WATER SUPPLY

Quality and ice making capacity are affected more by chemistry, temperature, and foreign matter in supply

water than any other factor. A survey made of water departments of large cities all over the country made it obvious that external filters or strainers should be installed. Such equipment is very effective in improving ice quality and reducing the frequency of cleaning out the ice making sections.

### CONNECTING WATER SUPPLY

A 1/2" female pipe fitting is provided on the right side of ice machine (Fig. 1B). Install the water screen provided with the machine. We recommend using 3/8" O.D. water inlet line.

### DRAIN CONNECTIONS

It is essential that drain connections be made so waste water can't back up into the head unit or bin. On water cooled models, a separate connection is provided for discharging condenser water. (Fig. 1C)

All connections are labeled. We recommend covering all incoming water and drain lines with a plumbing insulation material to prevent condensation. If the head unit and bin drains are tied together through a "T" connection, we recommend using a 3/4" pipe and a stand pipe vented to the atmosphere to prevent water traps. Drains must be at least 1/2" inside diameter and have 1/2" drop per 5 feet of run. If drains are not close enough to allow drop for proper drainage, or water is to be drained in a stationary sink higher than ice machine drains, use an automatic condensate disposal pump. (Check and follow local plumbing codes).

### CHECK LIST FOR STARTING MACHINE

Remove tape securing the damper doors, splash curtains and float valve.

Remove and discard screw securing the water pump mounting bracket to the cabinet wall. Raise the pump enough to remove the packing protecting the pump during shipment.

Remove corrugated packing from both ice chutes. Replace ice chutes and damper door. Screw ice chutes in place with screws provided.

Turn on water, and observe that the float valve shuts off the water when the level is about 2 inches deep. Should float require adjustment merely bend float rod carefully until desired water level is achieved. Turn the toggle switch to "water pump", left position.

The water pump will start pumping water into the tube located at the top of the evaporator. Return water will flow into the sump.

### CHECK FOR THE FOLLOWING THINGS

A higher than necessary water level wastes water and reduces ice making capacity.

Turn the machine on and off several times to slush clean water through the system and to observe that waste water drains properly.

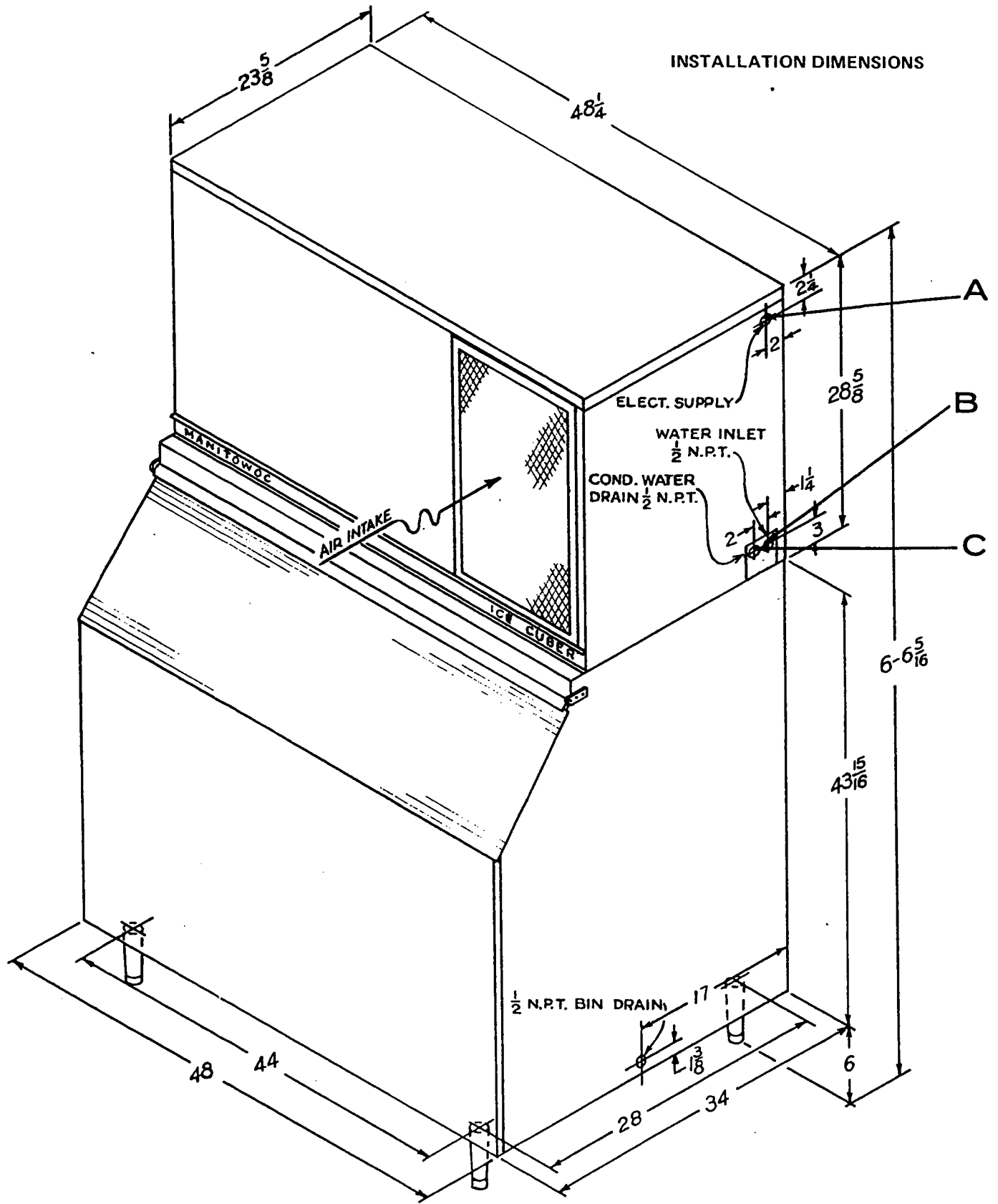

1100 SERIES  
C-900 BIN  
606 LEGS

FIG. 1

**START UP**

Place the "ON-OFF" toggle switch to the "ICE" position. Incorporated in the ice machine is a liquid line PUMP DOWN SYSTEM. When the machine is started you will note a delay of 30 to 60 seconds after the liquid line solenoid opens before the pressure control closes at 29 PSIG to start the ice machine.

Likewise when the ice storage bin is full the damper door opens, shutting the liquid line solenoid. The machine then pumps itself down until the pressure control opens at 1 PSIG to shut the machine off. Therefore, the machine will not shut off until the pressure control opens.

**ICE SIZE CONTROL**

Ice size is controlled by a reverse acting pressure control which activates a time clock. When the suction pressure pulls down to 14 PSIG the reverse acting pressure control closes. This activates the first time clock. This clock operates for approximately 6½ minutes. When this time elapses one hot-gas solenoid opens placing the front evaporator into harvest. Simultaneously the second timer starts and operates for 20 to 30 seconds. When this time elapses it opens the second hot-gas solenoid and places the back evaporator into harvest. This explains the 20 to 30 second delay between harvesting of the front and back evaporators.

When the back evaporator harvests, this trips the bin switch and places the machine back into the next freezing cycle. The reverse acting pressure control is set at a 7 PSIG differential, allowing it to open at 21 PSIG during harvest.

The installer should replace the top on the head unit, put the front and back panels in place, and check the first harvest of cubes to see that the machine functions properly.

The ice size controls consist of a Ranco or Penn reverse-acting pressure control (opens on pressure rise) and a Paragon timer clock. These controls are factory set and should need no adjustment except in altitudes above 5,000 feet.

**MANITOWOC'S FREEZE AND HARVEST CONTROL FOR 1100 SERIES MODELS AR & AD**

Freeze and harvest cycles on the above model Manitowoc Cubers are regulated by three very simple controls. The basic control is a low side reverse-acting pressure regulator made by either Ranco or Penn. The second control is a Paragon Timer located in the top of the ice machine. The third is a thermo disc installed on the suction line outlet of the evaporator. On starting a warm machine, the suction pressure may be upwards of 75 PSIG; but as the compressor runs, the suction pressure and temperature within the line is lowered. When the line temperature reaches 35 degrees F., the thermo disc

"cuts in" and closes the clutch on the timer and holds it "in" continuously through the freezing cycle. When the suction pressure reaches 14 lbs., the pressure control electrically activates the timer motor. The cam on the timer motor is set at approximately 4½. This is equal to 6½ minutes running time. The clock continues to run until the cam stalls against the harvest micro switch. This places the unit in harvest, and it will stay in harvest until released by the bin damper switch when the sheet of ice falls into the bin. The thermo disc remains closed during the entire harvest cycle. It opens only when the temperature of the suction lines rises to 65 degrees. This is a safety measure to prevent overheating in case the unit would stay in harvest.

If the dimple in the cubes is too pronounced, you may set the timer dial to 5. This will increase the freezing time. Likewise, if the bridging between cubes is too heavy, you may set the dial back to about 4. This shortens the freezing time.

**CONTROLS****HIGH PRESSURE CUT-OUT**

This shuts entire machine off, should the head pressure exceed 250 PSIG. (Water and air).

**SUCTION LINE THERMO DISC**

Suction line thermo disc is a safety control located on suction line. This control is a Thermodisc switch that opens at 65° F plus or minus 5° and closes at 35° F plus or minus 5°. The thermo disc acts only as a safety device to prevent overheating of the machine. Should the damper door switch fail after harvest, the thermo disc will open when the suction line temperature reaches 65° F plus or minus 5°. This will return the machine to its normal freezing cycle by disengaging the clock clutch located on the clock.

**TOGGLE SWITCH**

The main power "ON" and "OFF" toggle switch is a double pole, double throw switch with "OFF" in the center position. With the toggle switch in the "water pump" position, only the water pump operates. This is for checking the water inlet float level, pump operation, and for circulating cleaning solution.

With the toggle switch in the "ICE" (Right) position, the water pump, compressor and condenser fan (air cooled models), run for a normal ice making cycle.

**RANCO OR PENN PRESSURE CONTROL**

This control is a reverse-acting pressure control that opens on pressure rise. Upon decrease in suction pressure 14 lbs: the pressure control closes, actuating the time clock.

**PARAGON TIME CLOCKS (Primary and Secondary)**

After the pressure control energizes the time clock, the time clock motor turns a cam for 6½ minutes (number 4½ on the time clock face). When the 6½ minutes have elapsed, the cam trips a micro switch which in turn cycles the front evaporator into hot gas or harvest cycle. Simultaneously, the water pump and condenser fans shut off. Also the secondary timer starts and operates for 30 seconds. At the end of 30 seconds, the back evaporator cycles into harvest.

**DAMPER DOOR SWITCH**

When the harvest is completed, the ice falls through the damper door tripping the damper door switch. This, in turn, opens the holding clutches on the time clocks momentarily to reset the clocks and return the machine to its normal freezing cycle.

When the ice bin is full, the ice holds the bin switch open keeping the machine shut off. NOTE — Machine will not shut off until refrigerant system pumps down.

Should the damper switch fail, the suction line thermo disc will open to reset the time clocks.

Alternate location for damper door switch is in rear left corner of electrical compartment.

**SETTING TIMERS**

Should it be necessary to adjust the timer for an accurate bridge thickness, proceed as follows:

1. Remove the top from the machine.
2. Locate the primary timer (Fig. 2B)
3. Loosen adjustment screw, Fig. 3 "D".
4. To decrease bridge thickness, set arrow Fig. 3 "C" to number 3. Likewise to increase bridge thickness, set arrow to number 5.
5. Retighten set screw.

Fig. 2C indicates the secondary timer. This timer should not be adjusted. The primary timer Fig. 2B controls the bridge thickness of both evaporators.

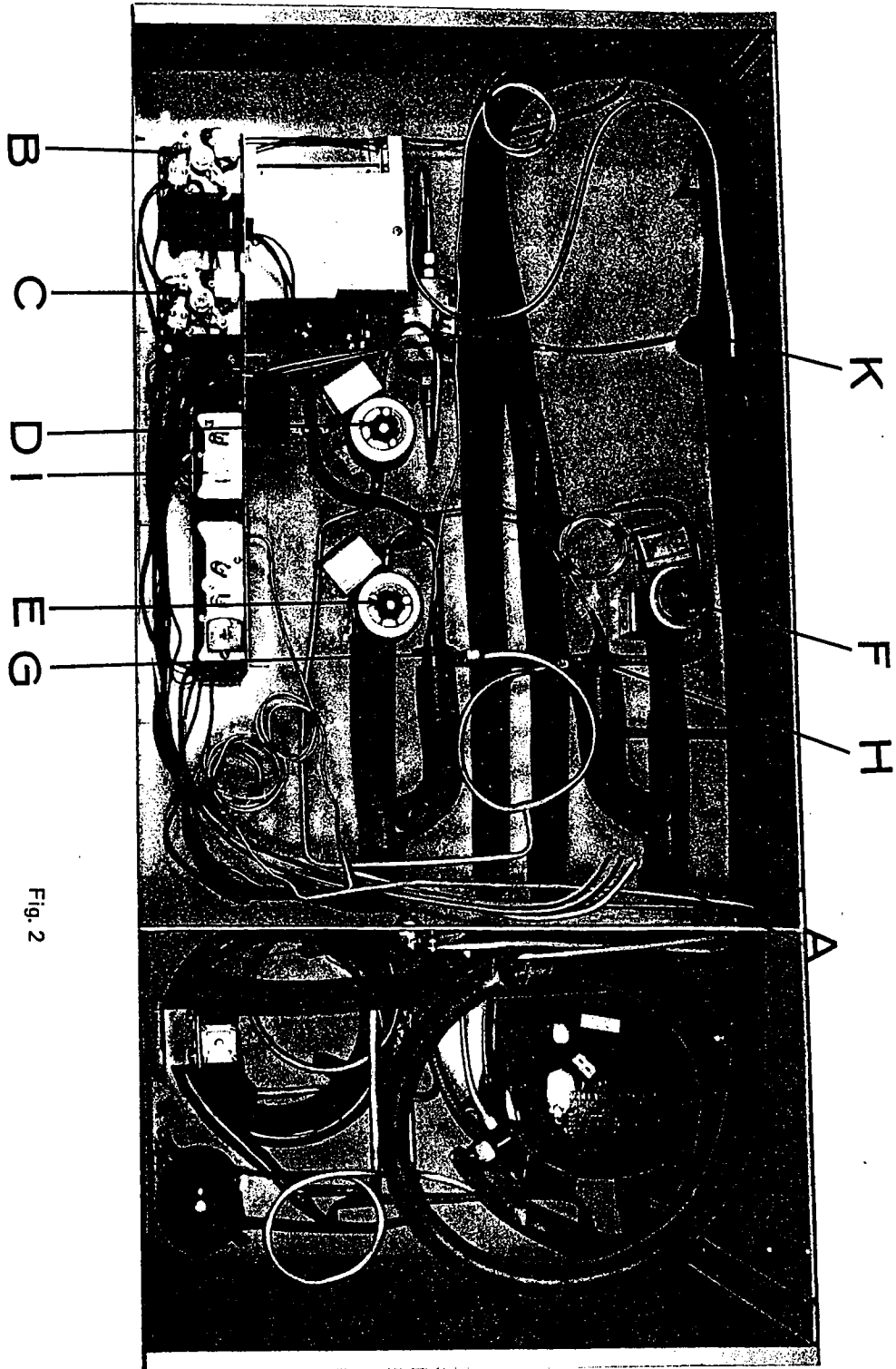

Fig. 2

- A. Electrical Lead Wires
- B. Primary Timer
- C. Secondary Timer
- D. Liquid Line Pump Down Solenoid
- E. Front Evaporator Hot Gas Solenoid
- F. Back Evaporator Hot Gas Solenoid

- G. Front Evaporator Expansion Valve
- H. Back Evaporator Expansion Valve
- I. Pressure Control (Reverse Acting)
- J. Combination Control – High Pressure Cut Out and Liquid Line Pump Down Pressure Control
- K. Thermo Disc

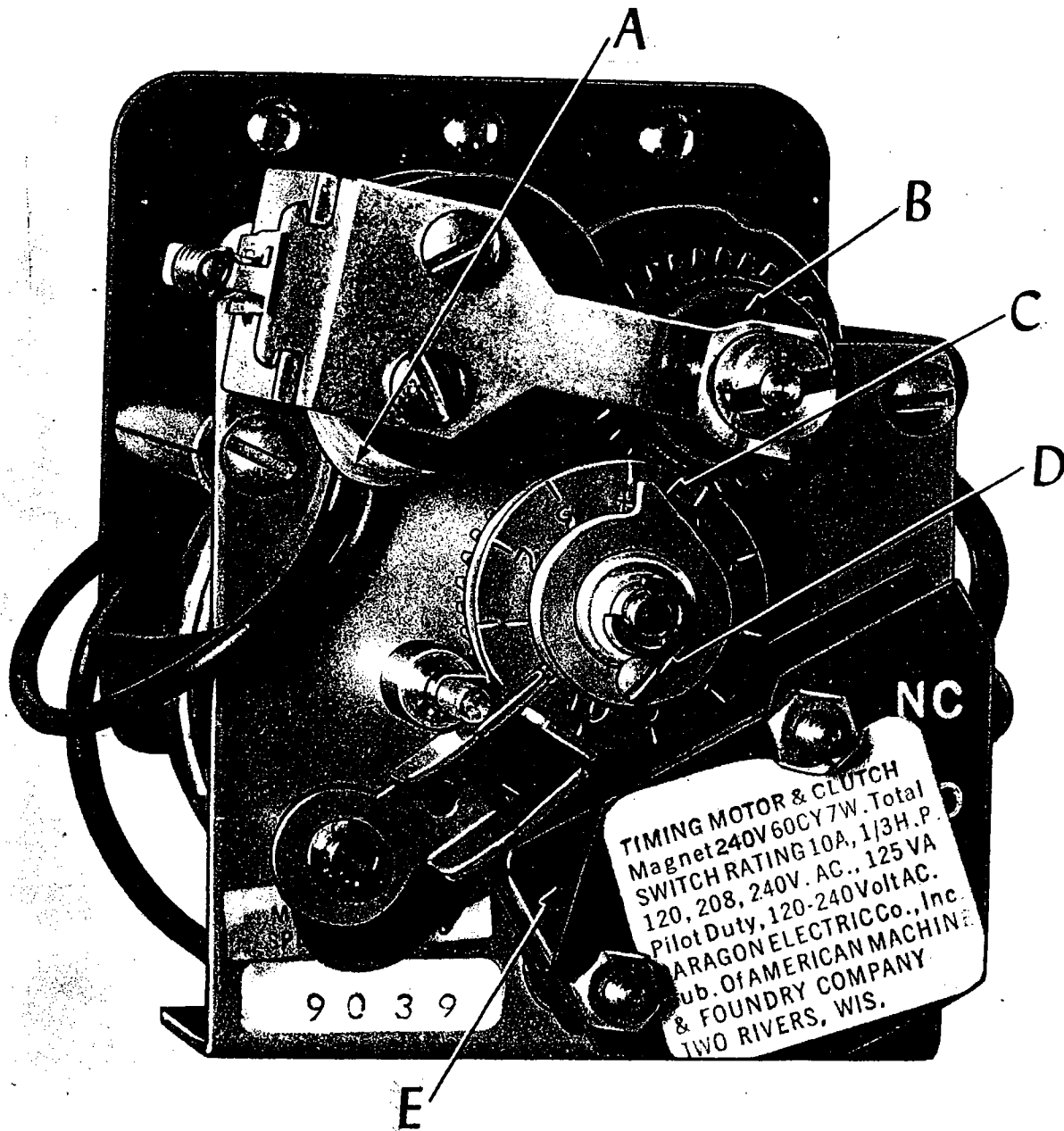

Fig. 3

- A. Clutch Coil
- B. Clutch
- C. Timer Setting
- D. Timer Setting Lock Screw
- E. Micro Switch

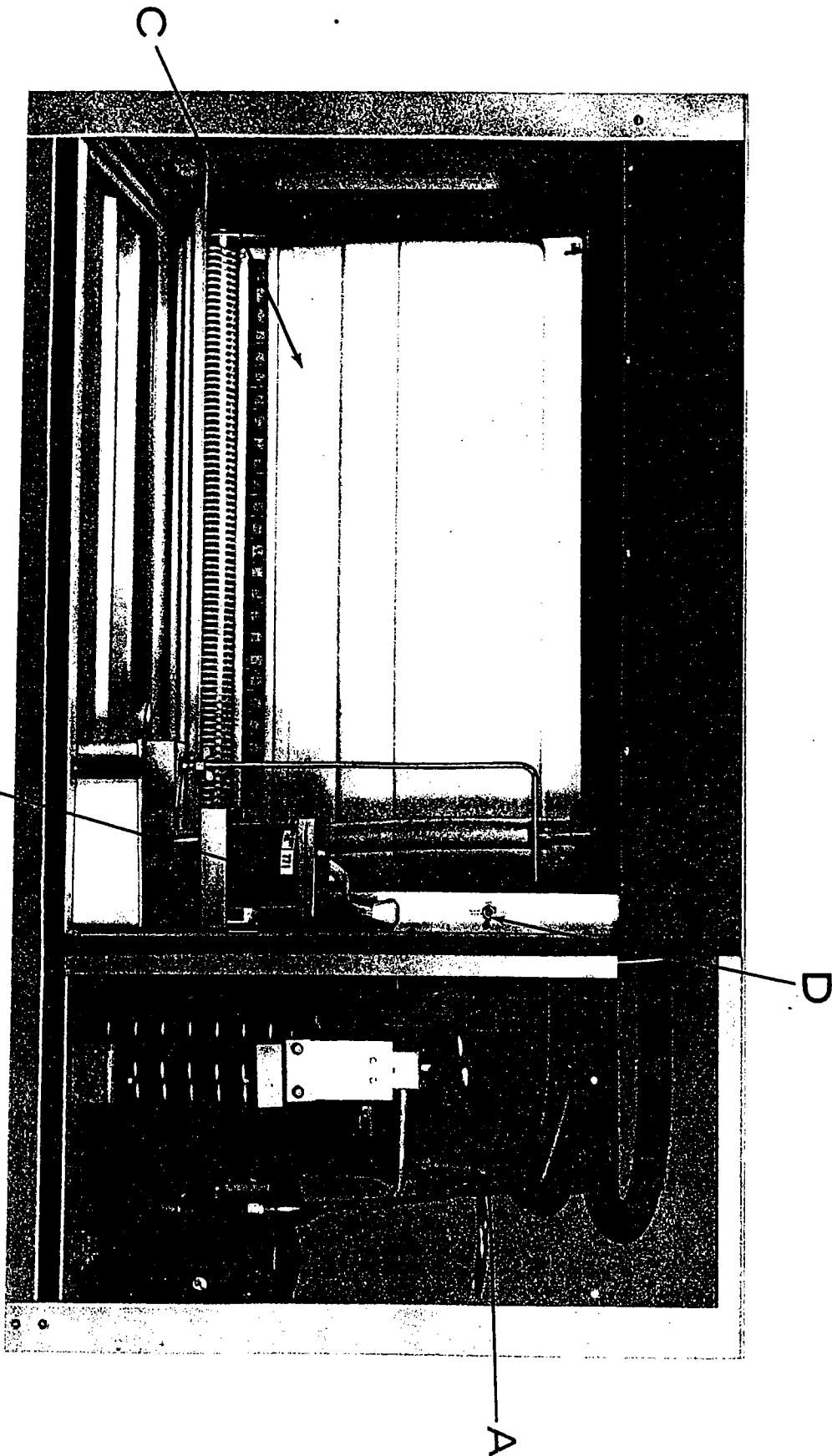

Fig. 4.

- A. Compressor
- B. Water Pump
- C. Evaporator
- D. On-Off Toggle Switch

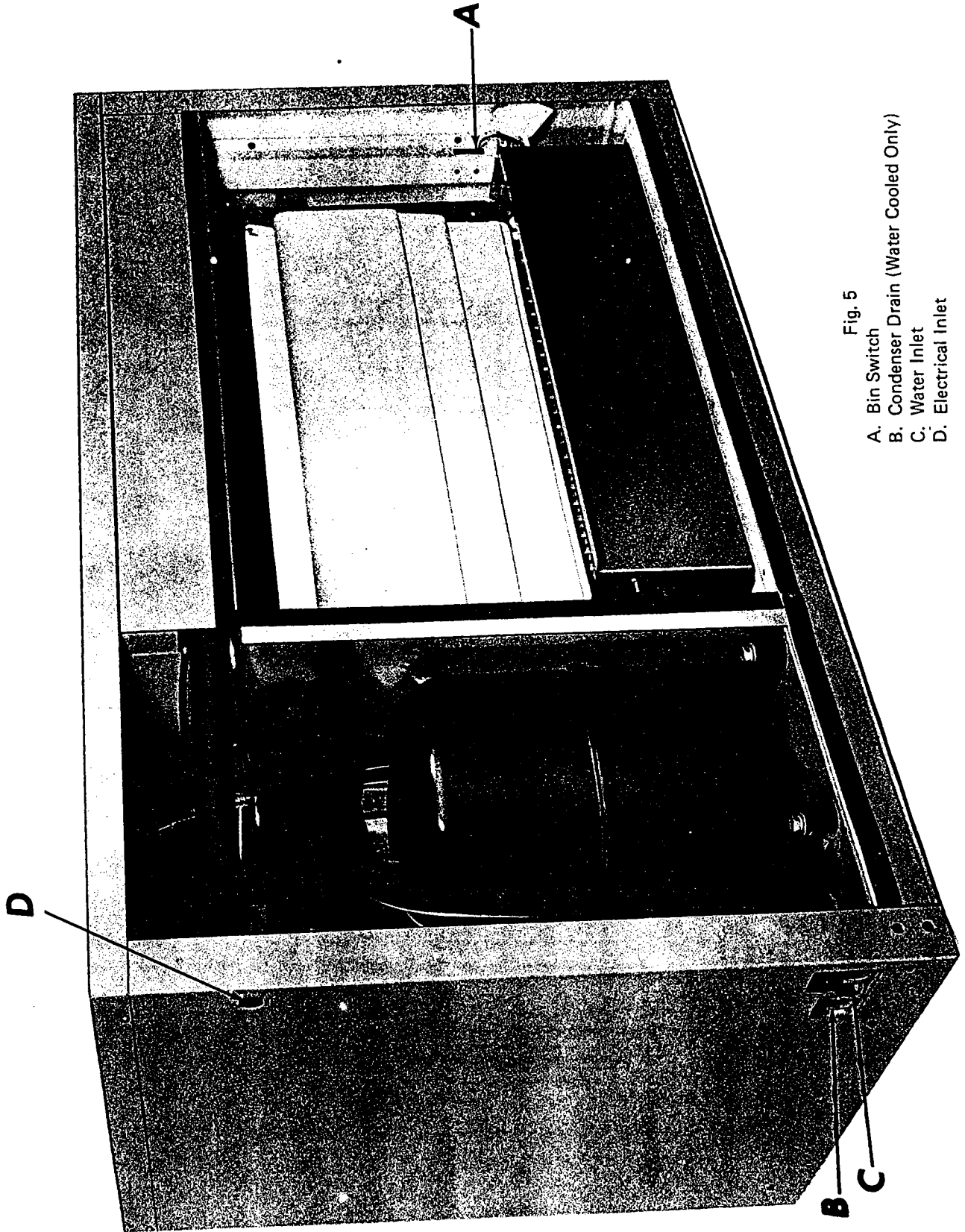

Fig. 5  
A. Bin Switch  
B. Condenser Drain (Water Cooled Only)  
C. Water Inlet  
D. Electrical Inlet

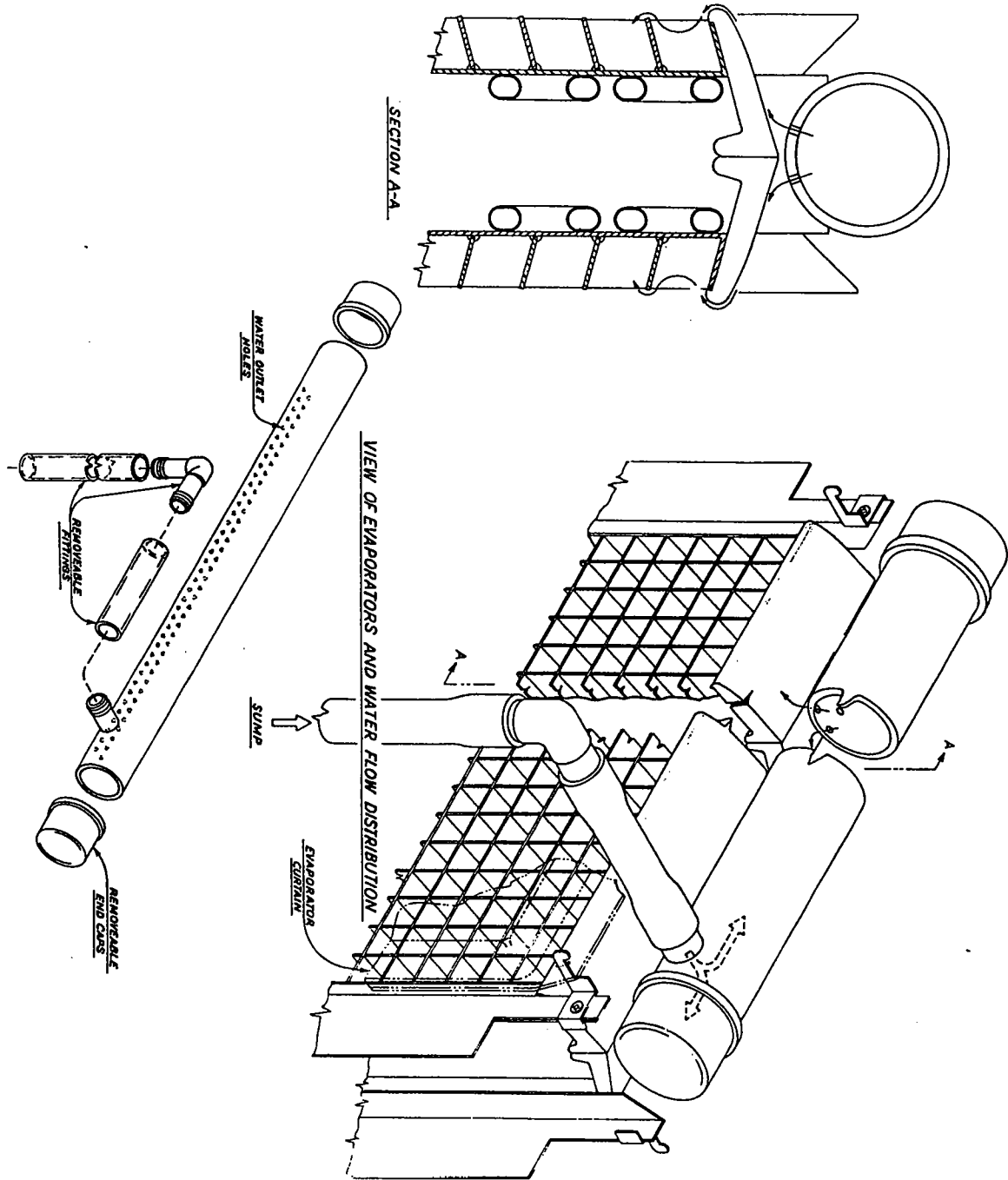

Fig. 6

WATER DISTRIBUTION ASSEMBLY

1100 SERIES

**ICE PRODUCTION – lbs. per 24 hours**

Regular Cube – 1-1/8"					Dice Cube – 7/8"				
MODELS	Incoming Water Temp F.	Room Temp. F.			MODELS	Incoming Water Temp F.	Room Temp. F.		
		70°	80°	90°			70°	80°	90°
AR-1100A	50°	1030	920	870	AD-1102A	50°	1040	940	880
	70°	910	840	780		70°	920	850	790
	90°	800	760	680		90°	820	770	700
AR-1101W	50°	1080	1050	1010	AD-1103W	50°	1100	1070	1030
	70°	940	930	910		70°	950	940	930
	90°	870	850	820		90°	880	870	850

**SPECIFICATIONS – Machine section only\***

MODELS	Regular Cube – 1-1/8'		Dice Cube – 7/8''	
	AR-1100A	AR-1101W	AD-1102A	AD-1103W
Height	28-5/8"	28-5/8"	28-5/8"	28-5/8"
Width	48-1/4"	48-1/4"	48-1/4"	48-1/4"
Depth	23-5/8"	23-5/8"	23-5/8"	23-5/8"
Approximate Shipping Weight	430	415	430	415
Electrical Characteristics (Other Voltages Available on special order)	115/230-60C Single Phase (AC)	115/230-60C Single Phase (AC)	115/230-60C Single Phase (AC)	115/230-60C Single Phase (AC)
Compressor Size	1½ H.P.	1½ H.P.	1½ H.P.	1½ H.P.

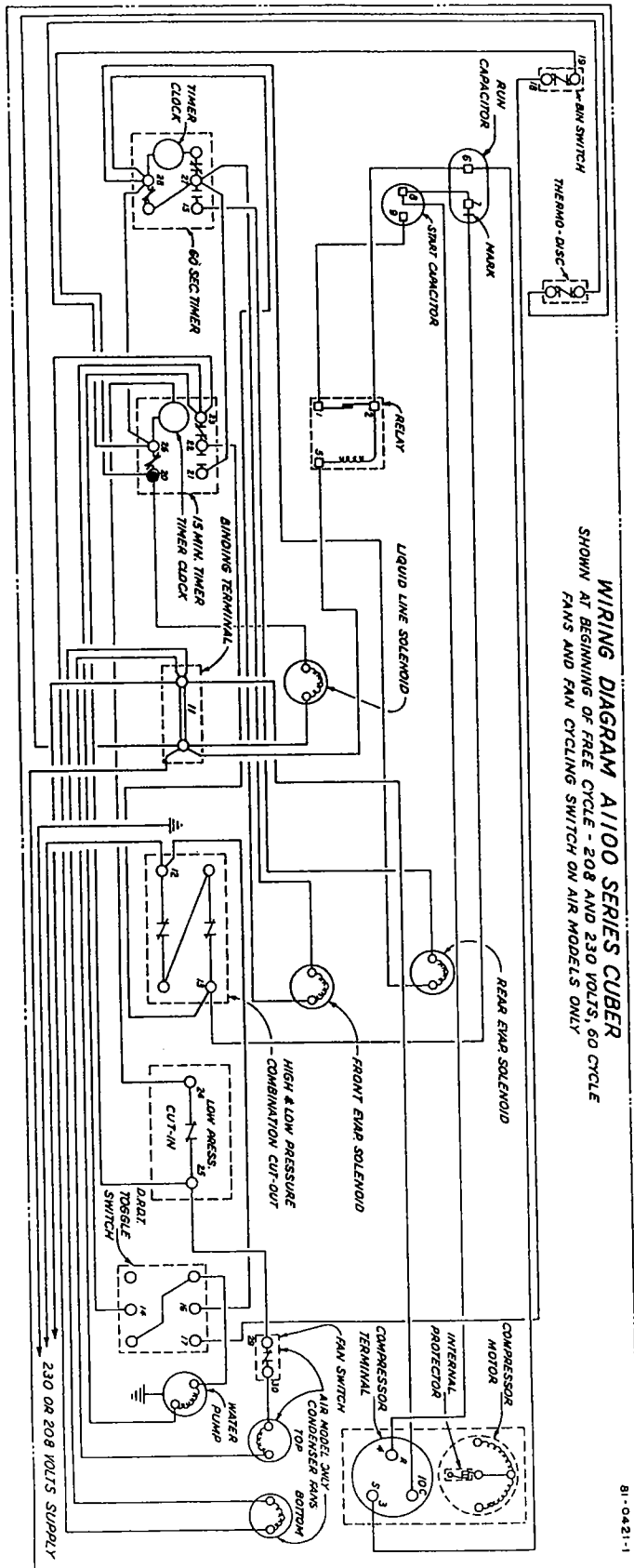

WIRING DIAGRAM A1100 SERIES CUBER  
 SHOWN AT BEGINNING OF FREE CYCLE - 208 AND 230 VOLTS, 60 CYCLE  
 FANS AND FAN CYCLING SWITCH ON AIR MODELS ONLY

81-0421-1

## A 2200 SERIES

This section contains service information for the following models:

AR-2200A Regular Cube – Air Cooled  
AR-2201 W Regular Cube – Water Cooled  
AD-2202A Dice Cube – Air Cooled  
AD-2203W Dice Cube – Water Cooled

The Manitowoc 2200 Series ice cuber consists basically of two 1100 Series Cubers in one cabinet.

### INSTALLATION

Uncrate machine and remove all packing and tape from inside of ice making section.

Install machine on bin and remove the front and side panels. There are two panels on each side and front.

### ELECTRICAL

Install the electrical connections through each hole in the rear of machine, and to the electrical box. See (Fig. 7A)

Lead wires are provided for hook-up.

NOTE – Each unit should be connected to a separate 220 volt power source, and fused with 20 amp. fuses.

### WATER CONNECTIONS

Connect the water supply to the fitting provided at the rear of machine. (Fig. 7B). On water cooled models a condenser water outlet fitting is also provided (Fig. 7C)

The water inlets are connected inside the machine to provide water for each unit. Likewise the condenser water outlets are connected to one common outlet.

Install the sump drains (Fig. 7D). This is for the ice making flush water.

### START UP

Switch both ON-OFF toggle switches to the ice position. Observe two cycles and check the ice bridge thickness. Adjust the primary timer if bridge needs changing.

MANITOWOC A-2200 SERIES HEAD SECTION SPECIFICATIONS

ICE PRODUCTION – lbs. per 24 hours

Regular Cube – 1-1/8"					Dice Cube – 7/8"				
MODELS	Incoming Water Temp F.	Room Temp. F.			MODELS	Incoming Water Temp F.	Room Temp. F.		
		70°	80°	90°			70°	80°	90°
AR-220QA	50°	2060	1840	1740	AD-2202A	50°	2080	1880	1760
	70°	1820	1680	1560		70°	1840	1700	1580
	90°	1600	1520	1360		90°	1640	1540	1400
AR-2201W	50°	2160	2100	2020	AD-2203W	50°	2200	2140	2060
	70°	1880	1860	1820		70°	1900	1880	1860
	90°	1740	1700	1640		90°	1760	1740	1700

Water Cooled

Height – Head Section 40 - 1/4"

Width – Head Section 43 - 1/4"

Depth – Head Section 34 - 3/8"

Approx. Shipping Weight 850 lbs.

Compressors 2 – 1 - 1/2 H.P.

Electrical Characteristics 208-230 V  
60 Cy. Single Phase AC

Finish Fawn Baked Enamel

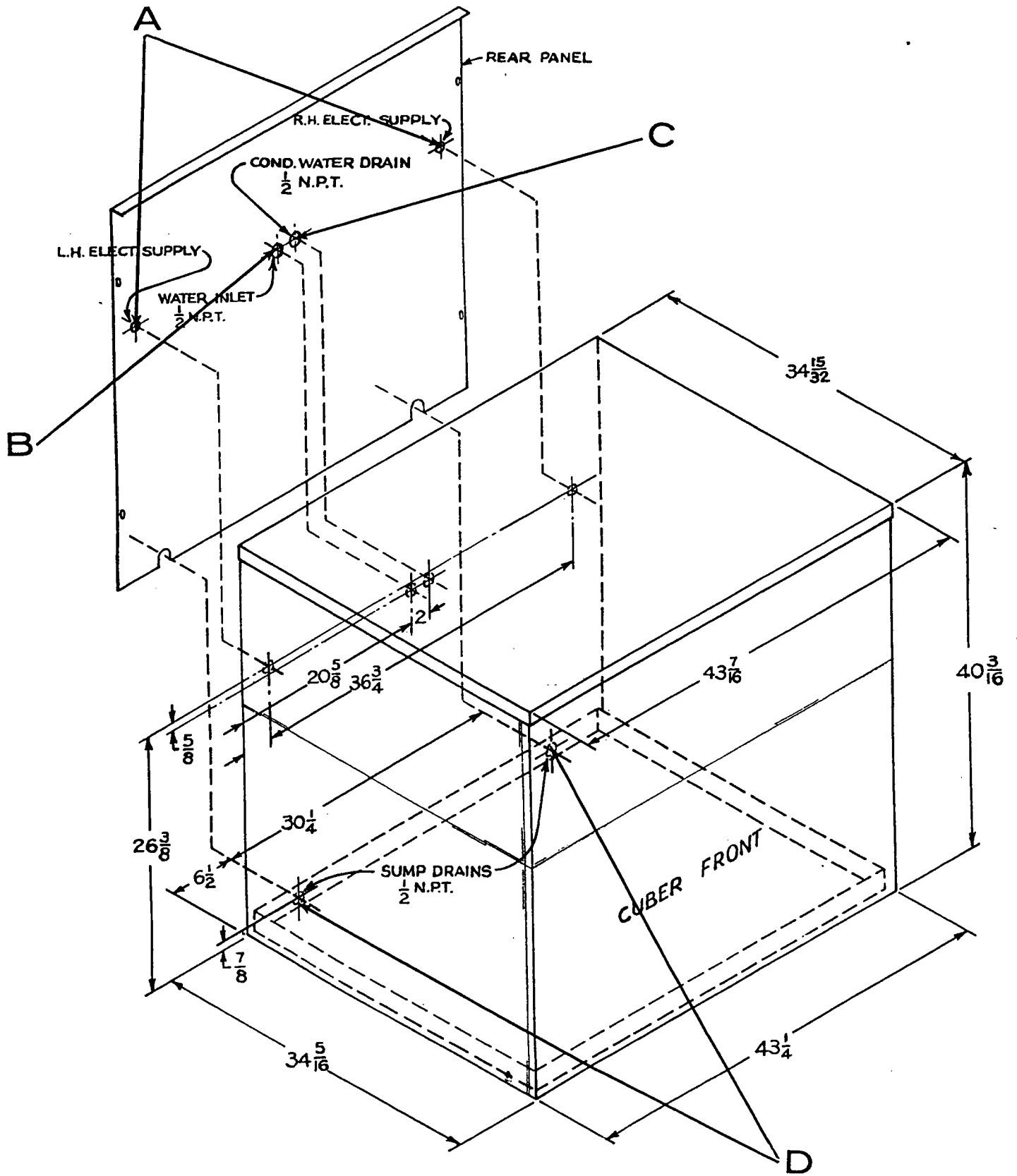

A-2200 SERIES CUBER (Water Cooled Only)

Fig. 7

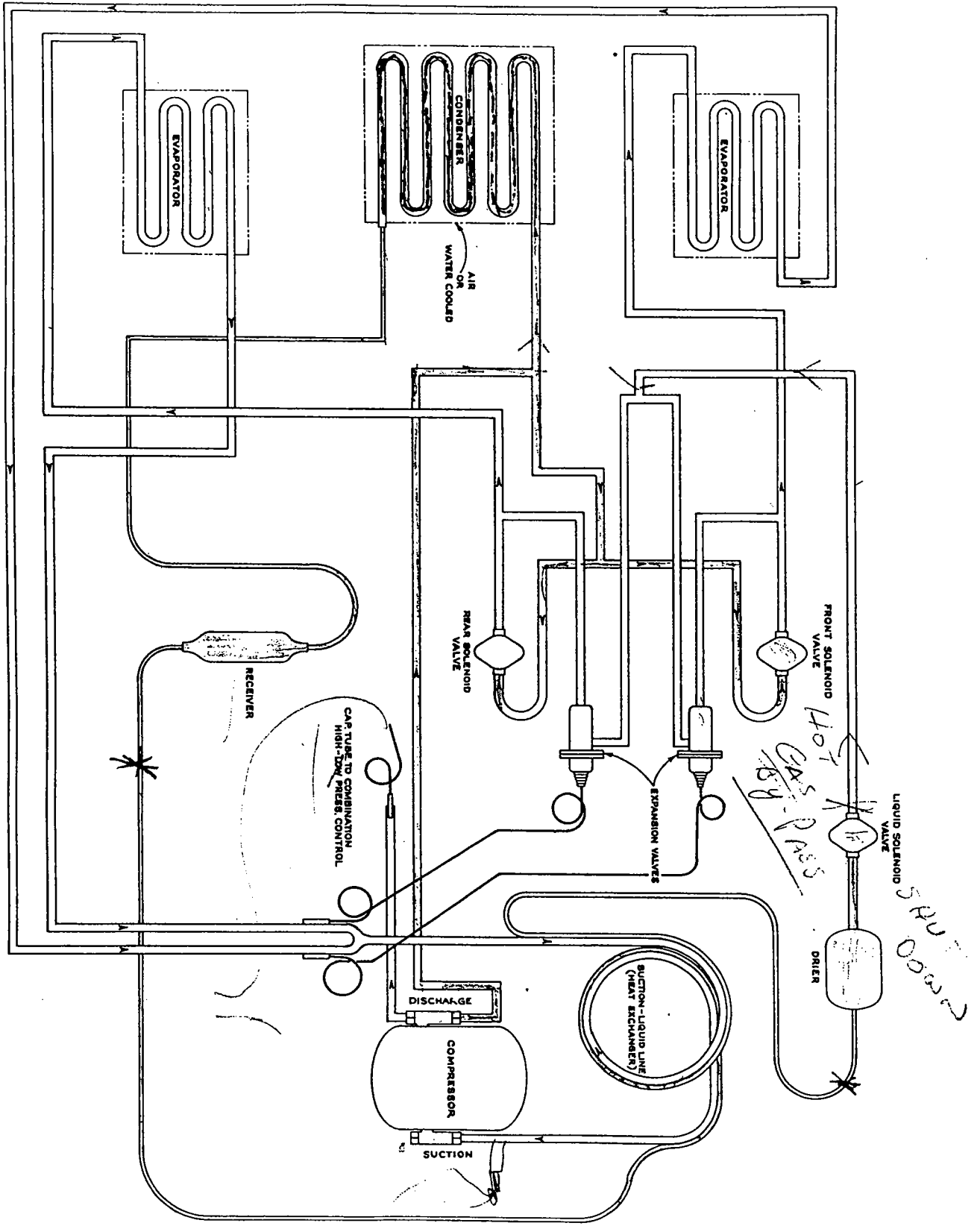

REFRIGERATION CYCLE  
Fig. 8

COMPLAINT	SERVICE ANALYSIS CAUSE	CORRECTIVE MEASURES
Slow harvest	Contaminated or limed water system Low ambient (air cooled models) Water valve set too low	Clean water system Must be above 50° F. Adjust water valve to 125 PSIG head pressure Replace water valve
High head pressure	Leaking water valve (water cooled models) Air in system Defective water valve (water cooled Models) Defective fan (air cooled models) Water valve not properly adjusted Contaminated air cooled condenser Defective expansion valve	Evacuate and recharge Replace water valve Replace fan Adjust water valve Clean condenser Replace
High suction pressure	Comtaminated condenser Defective fan Defective water valve (water cooled Models) Moisture in system	Clean Replace fan Replace or adjust water valve Replace drier, evacuate, and recharge
Low suction pressure	Shortage of refrigerant Moisture in system Ambient too low for operation	Locate leak and repair Replace drier, evacuate system Must be above 50° F
Unit noisy	Fan shroud touching fan blades	Adjust fan mounting brackets
Ice Maker will not stop when full of ice	Damper door not properly adjusted Defective damper door micro switch	Adjust damper door Replace damper door micro switch
Time clock will not operate	Ranco pressure control not closing	Replace control
Time clock will not actuate harvest	Timer micro defective Thermo disc is not closed	Replace micro switch Check thermo disc
Small cube bridge	Ranco pressure control not opening Leak in refrigeration system	Replace control Locate leak, repair, evacuate, and recharge
Machine will not cycle into harvest	Defective time clock clutch coil Defective time clock micro switch Defective thermo disc or thermo disc loose on suction line Moisture in refrigerant system	Replace Replace, or tighten on suction line
	Defective expansion valve	Discharge refrigerant, replace drier, evacuate, recharge Replace

CUBER MODEL	AR & AD 1100 and 2200 SERIES WATER COOLED			AR & AD 1100 and 2200 SERIES AIR COOLED		
	Compressor Model	YSB4-0150-CFV			YSB4-0150-CFV	
Compressor Voltage	208-230 volt - 60 cy. 1 ph.			208-230 volt - 60 cy. 1 ph.		
Winding Resistance Common to Run	.50 OHMS			.50 OHMS		
Winding Resistance Common to Start	4.6 OHMS			4.6 OHMS		
Start Capacitor Rating MFD/volts	135-155/320 V			135-155/320 V		
Run Capacitor Rating MFD/volts	25/370V			25/370V		
Fan Motor Model				Electric motors & specialty		
Fan Motor Amps				.7 AMPS		
Fan Motor Watts				35 Watt		
Fan Motor Volts				230 Volts		
Fan Winding Resistance				55 OHMS		
Solenoid Valve Volts	230 Volt			230 Volt		
Solenoid Valve Winding Resistance	210 OHMS			210 OHMS		
Hartell water pump winding resistance	35 OHMS			35 OHMS		
Hartell Water Pump Amperage	.72 AMPS			.72 AMPS		
Refrigerant Charge – R-12	45 ozs.			65 ozs.		
Normal machine amperage	15 AMPS			15 AMPS		

ROOM TEMPERATURE		70	90	110	70	90	110
HEAD	Maximum	125	125	125	145	175	216 PSIG
PRESSURE	Minimum	125	125	125	100	135	175 PSIG
SUCTION	Maximum	18	20	22	20	23	24 PSIG
PRESSURE	Minimum	7	7	8	7	9	10 PSIG

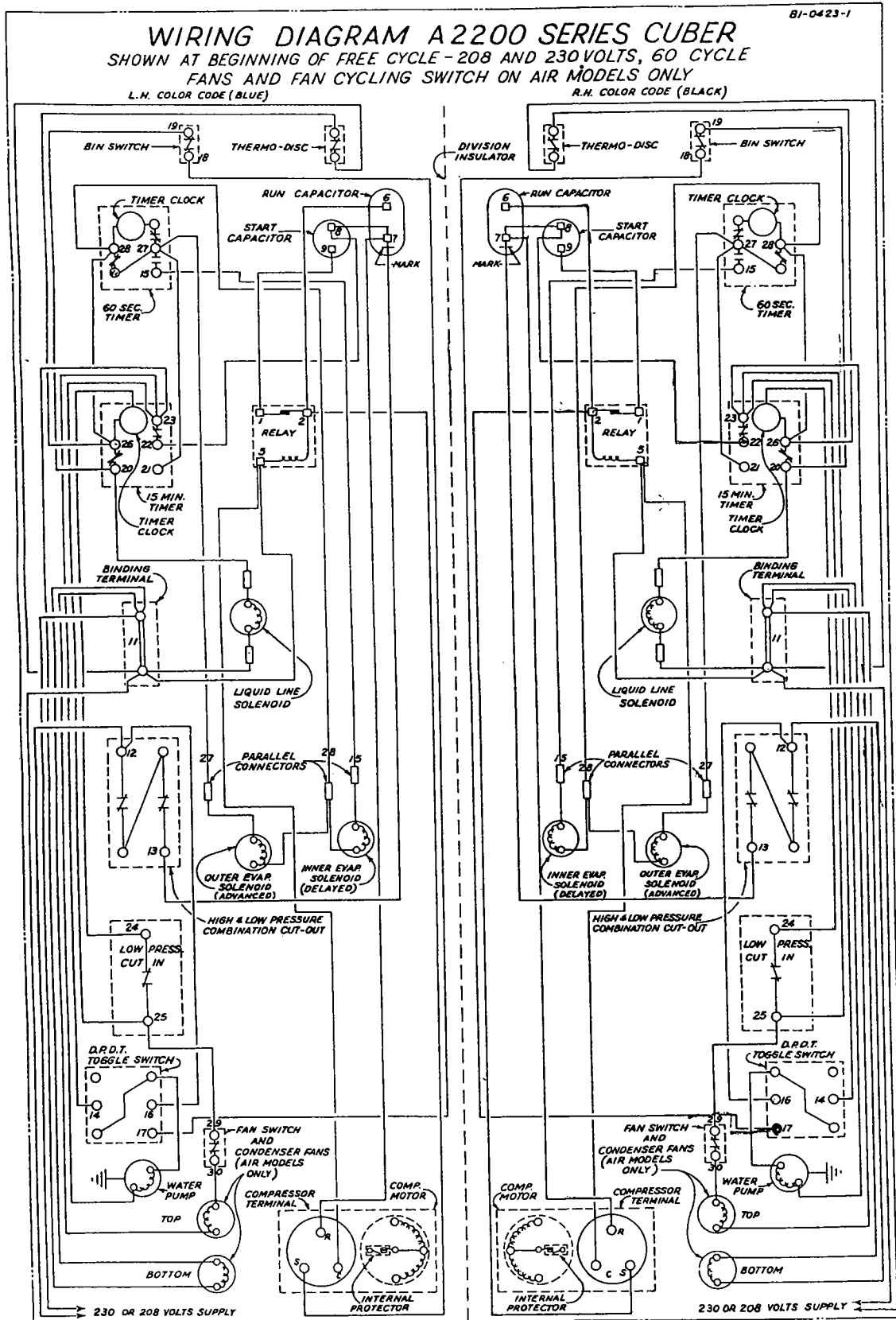

BASIC PARTS LIST	PART NUMBER
Compressor .....	14-0009-1
Relay .....	15-0283-1
Start Capacitor .....	15-0285-1
Run Capacitor .....	15-0284-1
Condenser (Air Cooled) .....	11-5020-1
Condenser (Water Cooled) .....	11-6504-1
Fan Motor .....	24-1207-1
Fan Blade .....	24-0189-1
Expansion Valve .....	13-6705-1
Solenoid Valve (Hot Gas) .....	24-0404-1
Solenoid Valve (Liquid Line) .....	24-0401-1
Thermo Disc .....	23-5088-1
Timer (Primary) .....	24-0607-1
Timer (Secondary) .....	24-0606-1
Bin Switch .....	23-0079-1
Toggle Switch .....	23-0056-1
Ranco Pressure Control .....	23-5079-1
Low pressure pump down & High Pressure Cut-Out Combination .....	23-5508-1
Water Distributor Assembly .....	C15186-1
Water Pump Assembly .....	14-8027-1
Float Assembly .....	13-6902-1

### SERVICE AND PARTS PROCEDURES

#### Order and Pricing Procedure

All replacement parts for the Manitowoc ice machine equipment are to be ordered directly from the factory; however, any distributors or dealers who may be interested in stocking replacement parts for the machines they sell, in order to provide their customers with a prompt and efficient service, may purchase these parts with the understanding that, any time they feel they have parts they no longer need or feel they no longer want to carry replacement parts, they are to notify the factory's Parts Department as to which parts they wish to return.

Upon receipt of this listing, we will immediately send them written authorization to return these parts; and upon receipt of these parts, full credit will be issued. There will be no charge for restocking these parts. Of course, credit can only be issued if the parts are returned in a new and unused condition.

When placing your order, be sure to do as follows:

1. Print name and address plainly.
2. If special routing is requested, please show the name of the carrier.
3. Indicate quantity desired, print catalogue part number plainly and print name as shown in the catalogue.
4. Indicate model and serial number of the unit. The complete serial number is needed.

5. If uncertain as to the proper part number, please give a complete description or sketch of the part and the location of the part which is needed.
6. Check to see that all required information is contained in your order to facilitate prompt shipment. All replacement parts are shipped from the factory on a f.o.b. Manitowoc basis. It is company policy to bill for all field replacement parts, according to terms as specified by our Credit Department.

All parts orders will be honored by the factory and will be billed according to our parts list schedules.

Parts which are covered by our warranty policy are to be returned to the factory for credit properly packaged, transportation charges prepaid. Upon receipt of these parts here at the factory, they will be inspected; and if they are found to be defective, in material and workmanship, under normal use and service, credit will be issued. Parts not properly packaged will be returned to the sender freight collect.

Transportation companies are responsible for damage in transit as all shipments are tendered to them in good condition; and our responsibility ceases upon receipt of a signed bill of lading from the carrier. If the shipment arrives in a damaged condition or is short, the delivery carrier should be notified immediately.

**Return of Defective Parts**

All defective parts returned to the factory, transportation prepaid, must be properly packaged to prevent further damage and tagged with a return material tag properly filled in. It is especially important that the cabinet serial number be secured and recorded on the tag, securing as much information as possible about the nature of the defect to prevent any delays in issuing credit. All parts should be returned as they are removed from the cabinet and not mutilated or tampered with. The return material tags are provided on a no-charge basis by the factory upon receipt of your request. Any part not properly packaged will be returned to the sender freight collect and no credit will be issued.

Our warranty and protection plan does not apply to cabinets that are not registered; therefore, it is necessary that, upon completion of the installation of the cabinet, the registration card be signed on the date of installation and mailed promptly to the factory Service Department in order for the cabinet to be registered.

**Return of Hermetically-sealed Units**

Extreme care should be used in servicing the hermetically-sealed mechanism. It is important that the trouble be correctly determined before the unit is changed. Be sure it is not the control, relay, or overload causing the trouble. The defect must be listed on the return material tag. Hermetically-sealed units must be returned with service valves closed and capped. All lines must be pinched and soldered shut.

**Return of Complete Machines**

No complete machines may be shipped back to the factory for repairs without first securing prior permission from the factory. If an unauthorized shipment is received at the factory, it will be refused by our warehouse and immediately returned to the sender. Upon receipt of your request to return a cabinet, if we feel that your request is legitimate, you will be sent an authorized return label authorizing you to return this cabinet to the factory freight prepaid.

# Ice M

From the Machine and normal use the hermetic

Our obligation replacing with parts of this prepaid, and defective.

This warranty flood, fire, Machine which except where consent.

We further contract for resulting from the normal use

This warranty agreement be equipment, at varied, supplied between the p

Sales are not implied warranty there are no in a particular p set forth above

To validate of installation Maniowoc, WI

DEALER \_\_\_\_\_

INSTALLATION \_\_\_\_\_

Form 80-0032-1 ALL

81-0453-1

## WIRING DIAGRAM A1100 SERIES CUBER 208 OR 230 V. 60 HZ., 3 PHASE SHOWN AT BEGINNING OF ICE-MAKING CYCLE, (HI & LOW PRESSURE SWITCH OF COMBINATION CONTROL IN NORMALLY OPEN POSITION), FANS & FAN-CYCLE SWITCH FOR AIR MODEL ONLY

**SPECIAL NOTE:** AS POWER IS CONNECTED, THE CUBER WILL RUN MOMENTARILY DESPITE THE TOGGLE SW. IN A NEUTRAL POSITION. THIS CONDITION IS DUE TO PRESSURE EQUALIZATION (DUE TO SHIPPING) OF THE HIGH & LOW PRESSURE SIDE. AS THE PUMP-DOWN CYCLE PROGRESSES, THE PRESSURE ON THE LOW SIDE DECREASES TO APPROX. 2 LBS., THEREBY SHUTTING CUBER DOWN.

### SEQUENCE OF ICE MAKING AND HARVEST CYCLE

1. SET TOGGLE SWITCH TO ICE MAKING POSITION, LIQUID SOLENOID & 15 MIN. TIMER COIL ARE ENERGIZED.
2. AFTER A SHORT TIME LAPSE, LOW PRESSURE CONTACTS OF COMBINATION CONTROL CLOSE (DUE TO INCREASING GAS PRESSURE)—CONTACTOR COIL, COMPRESSOR, WATER PUMP, TOP AND BOTTOM FAN ARE ACTUATED.
3. AS GAS PRESSURE DECREASES TO SET POINT (DUE TO SUFFICIENT ICE BUILD-UP) LOW PRESSURE CONTROL CUTS IN AND INITIATES 15 MIN. TIMER MOTOR.
4. AFTER A SET TIME INTERVAL, 15 MIN. TIMER MAKES A CONTACT TRANSFER, OPENING T.O. AND CLOSING T.C.—TIMER MOTOR, TIMER COIL OF 60 SEC. TIMER AND ADVANCED DEFROST SOLENOID ARE ENERGIZED. WATER PUMP, TOP AND BOTTOM FAN AND 15 MIN. TIMER-MOTOR ARE DE-ENERGIZED.
5. 60 SEC. TIMER IS TIMING OUT A SET DELAY TIME UNTIL CONTACT TRANSFER; OPENING T.O. AND CLOSING T.C., THEREBY ACTUATING DELAYED DEFROST SOLENOID (LOW PRESSURE CUT-IN TRANSFERS TO NORMALLY OPEN POSITION).
6. HARVEST OF DELAYED ICE SLAB OPENS BIN SWITCH. THIS IN TURN, MOMENTARILY DE-ENERGIZES LIQUID SOLENOID AND DISENGAGES THE CLUTCHES OF BOTH TIMERS.
7. THE CUBER IS NOW READY FOR A NEW ICE MAKING CYCLE.

