

Instruction Manual for
Food Equipment
Mixer

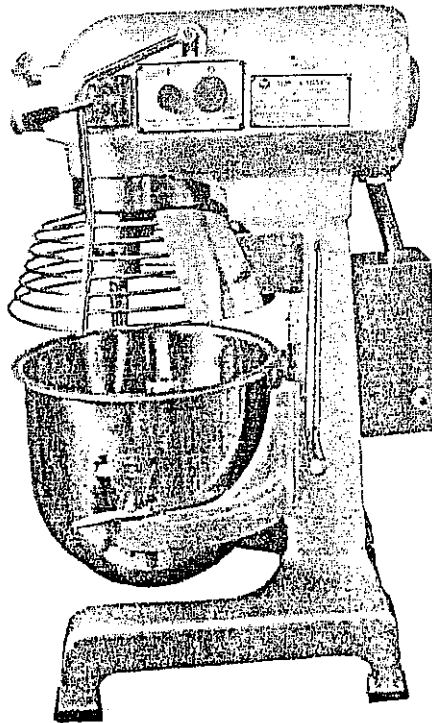

Important: Please Read Before First Use!

Guangdong Henglian Food Machine CO., LTD

Address: 95 Lijiang Road, Shilou, Panyu, Guangzhou China

Tel: +86(20) 84868083 84868086 Fax: +86(20) 84862988

TABLE OF CONTENTS

Installation	<u>3</u>
Components Identification	<u>4</u>
Accessories Identification	<u>5</u>
Technical Specification	<u>6</u>
Operations	<u>7</u>

Important Safeguards

M20A Mixers complies with all safety requirements of UL standards for commercial kitchen equipment & Canadian standards for Canada.

M20A Mixers complies with NSF

SAVE THESE INSTRUCTIONS

INSTALLATION

1. Unpack unit, accessories and instructional material carefully.
2. Check over equipment to make sure that there is not any damage to equipment.

Note: If equipment appears to be damaged contact carrier within ___ days from delivery.

3. Please read all instruction carefully before operating equipment.
4. Find a suitable operating area to install equipment.

Note: Make sure there is adequate space around equipment to allow the user to properly operate controls and remove and install accessories. Do not place machine in wet or damp area.

5. Lift equipment off of the floor to move, do not slide equipment across the floor.

Note: Do not handle or lift equipment alone; use the help of others.

6. Consult an electrician to assure the electrical supply complies with specified current(amp) capacity.
7. Do not plug in the same outlet shared by other equipment.
8. Do not use extension cord.
9. Keep all accessories clean and in a safe place so they do not become scratched or misplaced.
10. Do not expose the equipment to any moisture that may enter electrical box or components.
11. For safety purposes, do not remove any service covers, safety guards or warning labels.

COMPONENTS IDENTIFICATION

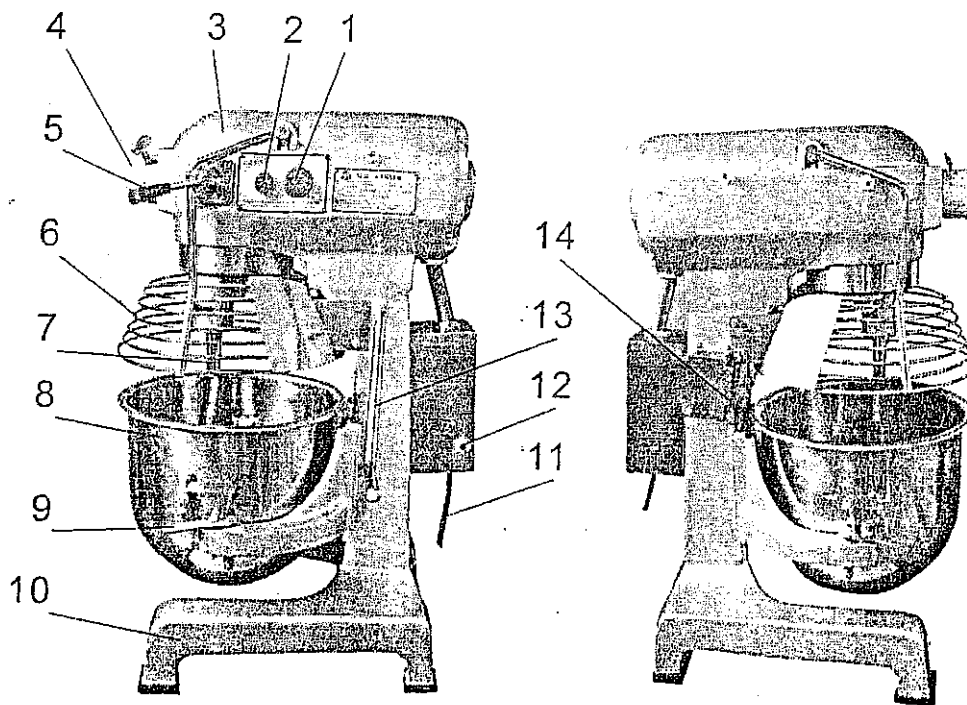

Figure A

1. Stop Button - push to stop/turn to release
2. Start Button - push to start
3. Top Cover
4. #12 Meat Grinder Attachment Hub – remove safety cover from #12 hub to attach accessory
5. Speed Switch - controls the mixing speed
6. Safety Guard - must be lowered into position during operation
7. Mixing Shaft – mixing accessories are attached to the mixing shaft
8. Bowl – holds mixing contents
9. Bowl Locks – secure bowl in place
10. Base – rubber protection on bottom to prevent rusting, scratching and sliding
11. Power Cord – plug into current compliant electrical outlet
12. Reset Button – press to reset unit incase of overload
13. Bowl Lever – raises and lowers bowl.
14. Operation Safety Switch – engages when bowl is raised & locked into place.

ACCESSORIES IDENTIFICATION

- 1) Bowl - 20qt. mixing bowl
- 2) Dough Hook - suitable for mixing flour in low speed mode
- 3) Flat Beater - suitable for mixing crushed powdered in medium speed mode
- 4) Wire Whisk - suitable for mixing liquids in high speed mode
- 5) Meat Grinder - optional attachment - suitable for grinding meat

1). Bowl (20qt. Mixing bowl)

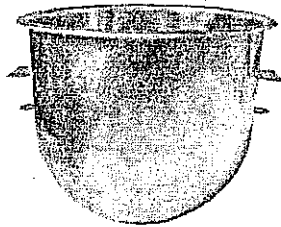

Figure B

2). Dough Hook (to use for mixing flour) in low speed mode.



Figure C

3). Flat Beater (to use for mixing crushed powdered) medium speed.

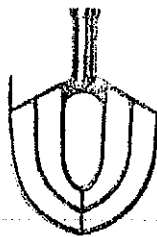

Figure D

4). Wire Whisk (suitable for mixing liquids) high speed.



Figure E

5). Meat Grinder (optional).

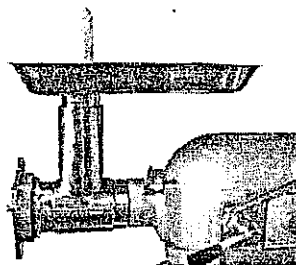

Figure F

TECHNICAL SPECIFICATIONS

Note: Select speed according to specified accessory mode

1. **Dough Hook** - suitable for mixing flour and bread dough on the low speed mode

Note: Mix should equal 45% to 50% of the flour weight (See Figure G)

2. **Flat Beater** - suitable for mixing crushed, powdered and pasty food, such as stuffing on medium speed mode (See Figure H)
3. **Wire Whip** - suitable for mixing liquid food, such as cream, egg on high speed mode (See Figure I)



Figure G

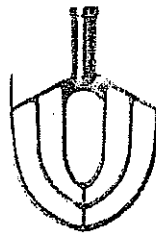

Figure H



Figure I

Model	Bowl Volume	Motor	Frequency	Power	Mixing Speed	Maximum Kneading Capacity	Dimensions	Net Weight
M20A	20 qt.	1 phase	60 Hz	1 hp	106/180/367 rpm	13 lb/hr	19"x17"x31"	230 lb

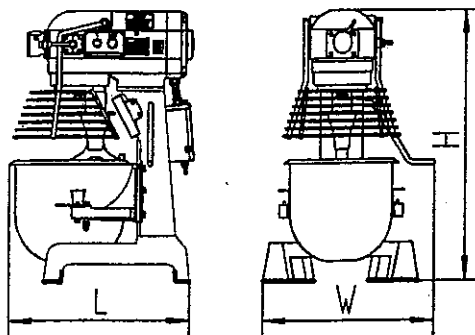

Figure J

OPERATIONS

1. Make sure the equipment is properly installed.
2. Attach accessory suitable for mixing needs to mixing shaft 7.

Note: Be careful not to scratch or damage the mixing bowl 8 when assembling accessories.

3. Secure the bowl using the bowl locks 9 on both sides of bowl.
4. Pour contents into mixing bowl 8.
5. Turn bowl lever 13 clockwise into locked position.

Double check that all steps have been completed

6. Lower safety guard 6.
7. Turn speed switch to suggested speed for intended use 5.

Note: For safety purposes, stop unit before changing speeds

8. Make sure stop button 1 is released.
9. Plug in power cord 11.
10. Press start button 2.
11. Before checking contents, press stop button 1.
12. Lift guard 6 to check contents.

Note: A safety feature will turn off the machine if it is overloaded. If this occurs first wait a few minutes and then press reset button 12.

13. This unit can work in the #12 mincer attachment. If the user want it, please point out especially, and pay for it.

PARTS LIST

The movement of the attachments is gear driven. There is enough lubrication in to the shift box, however, add lubrication to the gear box once every four months. *Mike to send us a maintenance sheet and service manual.*

If service is required beyond daily maintenance refer to a qualified personal or call our service number located on the first & last page of this booklet.

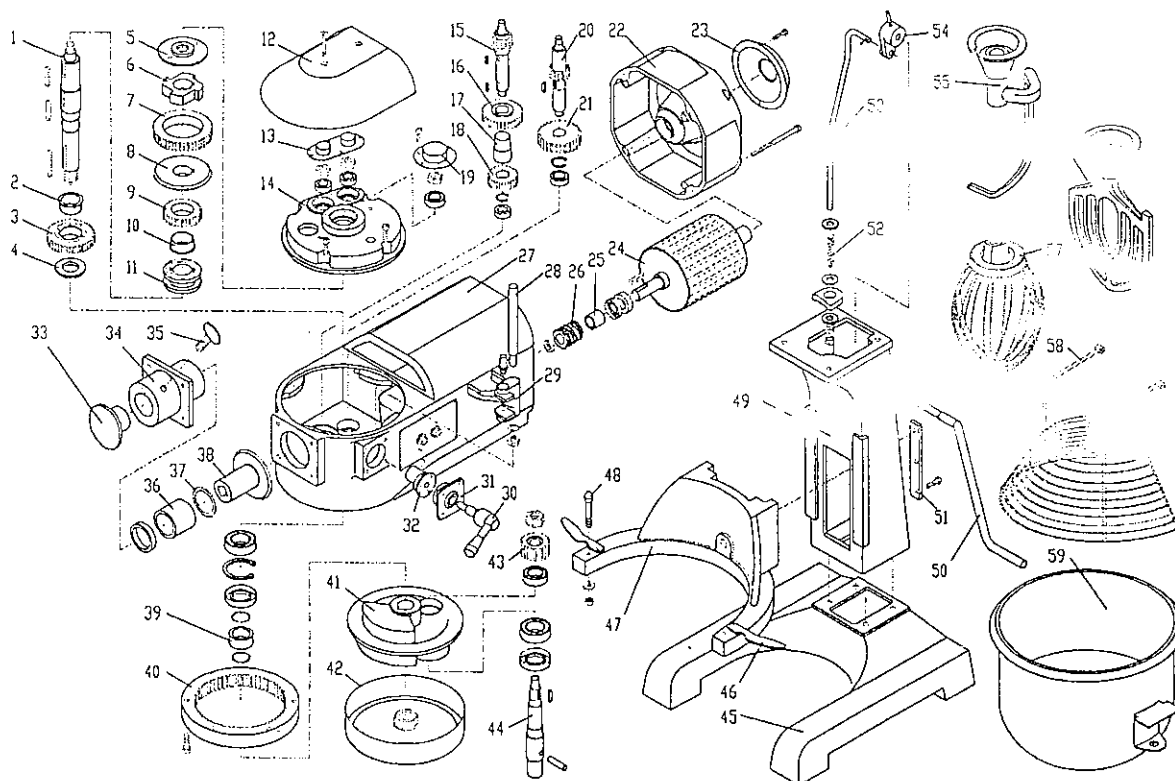

PARTS LIST A

Figure L

Illus	Part NO	Name Of part	AMT				
1	M20A-05-17	Principal axis	1	30	M20A-05-48	Shift handle	1
2	M20A-05-30	Axis cover	1	31	M20A-05-49	Handle seat	1
3	M20A-05-31	Joint gear Z=38	1	32	M20A-05-47	Eccentricity cover	1
4	M20A-05-29	Gasket	1	33	M20A-05-01	Front cover	1
5	M20A-05-18	Press cover	1	34	M20A-05-13	Twist tie-in seat	1
6	M20A-05-19	Clutch	1	35	M20A-05-02	Lock bolt	1
7	M20A-05-16	Gear Z=47	1	36	TA3530Z	Roll pin bearing	1
8	M20A-05-15	Big cone gear Z=46	1	37	M20A-05-35	Adjust gasket	1
9	M20A-05-34	Small joint gear Z=29	1	38	M20A-05-14	Small cone gear Z=36	1
10	M20A-05-30	Axis cover	1	39	M20A-05-28	Airproof cover	1
11	M20A-05-32	Zygosperm	1	40	M20A-05-37	Annular gear Z=67	1
12	M20A-01	Top cover	1	41	M20A-05-36	Whip seat	1
13	M20A-05-06	Cover	1	42	M20A-05-40	Oil receiver	1
14	M20A-05-23	Bearing seat cover	1	43	M20A-05-38	Planet gear Z=19	1
15	M20A-05-21	Gear shaft Z=15	1	44	M20A-05-39	Whip shaft	1
16	M20A-05-22	Gear Z=33	1	45	M20A-15	Base	1
17	M20A-05-26	Bush	1	46	M20A-24	Bowl press plank	2
18	M20A-05-27	Gear Z=23	1	47	M20A-17	Slide rack	1
19	M20A-05-05	Cover	1	48	M20A-23	Roll starting pin	2
20	M20A-05-25	Gear shaft Z=17	1	49	M20A-11	Exist pole	1
21	M20A-05-24	Worm wheel Z=29	1	50	M20A-07	Handle	1
22	M20A-05-11	Back cover	1	51	M20A-11	Press plank	2
23	M20A-05-12	Back cover plate	1	52	M20A-12	Spring	1
24	M20A-	Rotor module	1	53	M20A-09	Connecting haulm	1
25	M20A-05-09	Worm bush	1	54	M20A-06	Link haulm	1
26	M20A-05-08	Worm	1	55	M20A-19	Whip haulm	1
27	M20A-05-10	Box body	1	56	M20A-18	Mix ware	1
28	M20A-05-46	Dial fork axis	1	57	M20A-20	Whisk	1
29	M20A-05-45	Dial fork	1	58	M20A-	Shield	1
				59	M20A-21	Bowl	1