



**Changing**  
*how food is served.*

## OPERATION/MAINTENANCE MANUAL



 **QuickSwitch**<sup>™</sup>

**QUICKSWITCH SERIES**  
**SPC-SIM QSP-X Units**

**CUSTOM FABRICATORS OF FOODSERVICE EQUIPMENT**

1947 Bill Casey Parkway • Jonesboro, GA 30236  
Tel: 1-888-584-2722 • Fax: 1 (770)-471-3715  
[www.lowtempind.com](http://www.lowtempind.com)

# **Table of Contents**

INSPECTION.....	3
SAFETY PRECAUTIONS.....	3
NOMENCLATURE.....	6
UNIT INSTALLATION INSTRUCTIONS / SPECIFICATION .....	7
Openings .....	7
OPERATING INSTRUCTIONS .....	10
Initial Setup/Guidelines: .....	10
Powering On the Unit .....	11
Turning on the HOT, COLD, FREEZE .....	11
Changing the Factory Settings .....	11
Temperatures of Hot, Cold, and Freeze.....	12
Powering Off the Unit .....	12
Auto Setting on the Controllers .....	12
CLEANING INSTRUCTIONS.....	13
PREVENTATIVE MAINTENANCE .....	13
TROUBLESHOOTING.....	13
REPLACEMENT PARTS .....	16
INIT INSTRUCTIONS.....	17
DIP SWITCH SETTINGS.....	18
WIRING DIAGRAMS.....	19
WARRANTY .....	27

## **INSPECTION**

Upon receipt, the crate should be inspected for visual damage. Any damage should be reported immediately to the carrier.

## **SAFETY PRECAUTIONS**

This manual includes safety and operating instructions for QS series drop in hot, cold, freeze food wells. LTI recommends reading all safety precautions and statements to ensure safe operation before installing and operating. Below are the precautions that are explained in more detail. Please read carefully.

### **DANGER**

Danger warns of imminent hazard which will result in serious injury or death.

### **WARNING**

Warning indicates the presence of a potential hazard or unsafe practice that will or can cause severe personal injury or death.

### **CAUTION**

Caution indicates the presence of a hazard or unsafe practice that will or can cause minor or moderate personal injury if the caution is ignored.

### **NOTICE:**

Used to note information that is important but not hazard-related.



## **WARNING**

### **ELECTRIC SHOCK HAZARD**

- Unit must be installed by a qualified electrician. Installation must conform to all local electrical codes. In the absence of local codes, use the latest version of the National Electrical Code.
- Unit should be safely and adequately grounded in accordance to local codes, or in the absence of local codes, the most up to date version of the National Electrical Code ANSI/NFPA70, to protect the user from electrical shock.
- The unit requires a grounded system and a dedicated circuit.
- The unit must be serviced by qualified personnel only. Service by unqualified personnel may lead to electric shock or burn.
- Control panel must be mounted on a vertical surface/wall and installed in the vertical position. Mounting control panel in the horizontal position may result in collection of liquids and lead to electrical shock.
- Turn OFF power, unplug power cord/turn off power at circuit breaker, and allow unit to cool if needed to before performing any cleaning, adjustments, or maintenance.

### **FIRE HAZARD**

- Risk of fire do not install closer than 1 inch to sides and bottom of unit.
- Do not use flammable cleaning solutions to clean this unit.



## **CAUTION**

### **BURN HAZARD**

- Exterior surfaces on the unit may become hot. Use caution when touching these areas.
- Drain water may reach temperatures in excess of 200°F (93°C). use appropriate plumbing materials when installing drain lines.

### **NOTICE:**

- Units are voltage specific. Refer to specifications label for electrical requirements before installation.
- Units are intended for indoor use only. Recommended room temperature 86°F.

- Units require a minimum of 330 CFM of fresh airflow across the condenser. Failure to provide proper airflow can cause premature compressor failure and will void any factory warranty.
- Service access must be incorporated in order to service and gain access to components.
- Do not recirculate exhaust air inside the cabinetry in front or behind the condensing unit for adequate ventilation.
- Install and transport unit in a upright position. Failure to do so may result in damage of refrigeration components.
- Use non-abrasive cleaners and cloths only. Abrasive cleaners and cloths could scratch finish of unit, marring its appearance and making it susceptible to soil accumulation.
- Do not use steel wool for cleaning.
- Do not use harsh chemicals such as bleach, cleaners containing bleach, or oven cleaners to clean this unit.

## **NOMENCLATURE**

**SPC – QSP – DW – LP – 20 – 04 – 68**

A    B    C    D    E    F    G

### **A – COUNTER STYLE**

SPC – SPECLINE

SIM – SIMPLICITY

### **B – QSP = QUICKSWITCH PAN**

### **C – PAN STYLE**

DW = DRY/WET

D = DRY

### **D – BODY STYLE**

MF- MOLDED FIBERGLASS

FP – FIBERGLASS PANEL

LP – LAMINATE PLASTIC

LSS – LAMINATE OVER STAINLESS

SS – STAINLESS STEEL

### **E – WIDTH OF PAN**

20 – STANDARD 20"

12 – SLIM 12"

### **F – NUMBER OF STANDARD 12X20 PANS THE UNIT HOLDS**

### **G – BODY LENGTH**

SPC LENGTHS SPECIFIED BY ORDER

SIM LENGTHS = 36,50, & 66

## **UNIT INSTALLATION INSTRUCTIONS / SPECIFICATION**

**LTI: QuickSwitch Series** is a refrigeration and heating system designed for short term display and dispensing of cold & hot food products in maximum ambient temperature of 86°F. This unit will maintain cold food product temperature when in the cold mode at 40°F or lower up to 4 hours and hot food temperatures when in the (Hot) mode at 150°F or higher for up to 2 hours. This unit is designed for temporary storage of product. They should not be used as long-term storage of bulk product. Refer to figures and tables provided below for standard cut out sizes for the QS.

### **Openings**

#### **IMPORTANT NOTE:**

Self-contained refrigerated units require a minimum of (230 cubic feet per minute) of fresh airflow across the condenser for proper operation of the compressor.

**ATTENTION:** *Failure to provide proper airflow can cause premature compressor failure and will VOID any factory warranty.*

#### **Ventilation Openings**

A recommended minimum opening of 16" X 16" (256 square inches) is required in front of the condenser. The rear must have an opening to permit the exhaust of heated air. The recommended rear opening is 16" X 16" (256 square inches).

Louvered or grilled style panels should have a minimum 75-85 sq in total open area and positioned in front of the condenser and shrouded.

#### **Service Access**

These units have multiple components on the right and left side of the condensing unit. They include the electrical power, master switch, and main control board on the right. As well as the drain manifold and TXV expansion valve access on the left. Due to this it is required to have the service access incorporated with the ventilation opening on the side that these components are on. **Refer to the illustration provided for recommended access to these components.**

#### **Plumbing**

Each food well comes with an individual 3/4" drain valve. These valves are manifolded to one common drain line for final connection in the field. Access to these valves is necessary to drain water out of the wells. Refer to illustration provided for more details.

# SIM/SPC - QSP

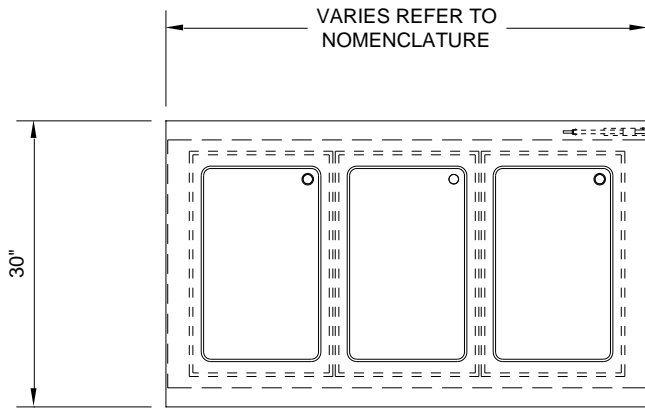

PLAN

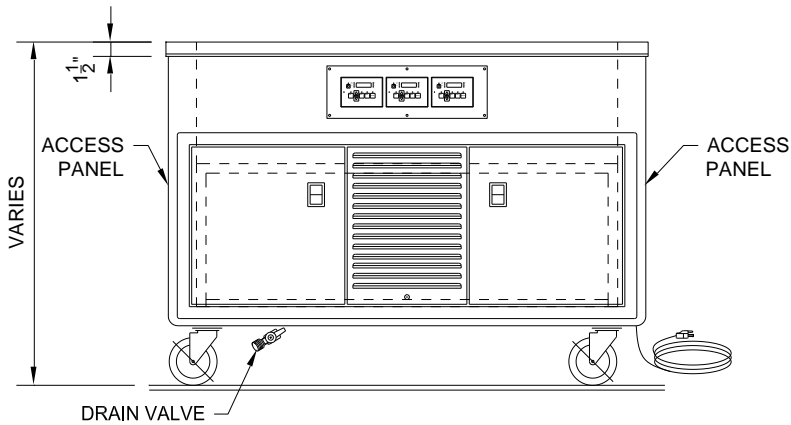

ELEVATION

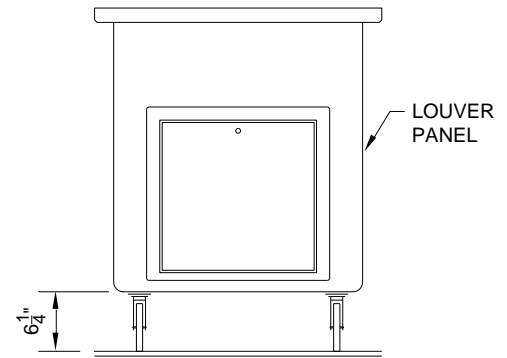

END ELEVATION

## SPC/SIM-QSP MODEL ELECTRICAL/REFRIGERANT INFORMATION

MODEL	PANS	120V/1/60HZ		120/208/1/60HZ		120/240/1/60HZ		REFRIGERANT	CHARGE OZ
		AMPS	PLUG	AMPS	PLUG	AMPS	PLUG		
SPC/SIM-QSP-X-X-20-01-X	1	7.2	5-15P	7.2	14-20P	7.2	14-20P	R449A	16
SPC/SIM-QSP-X-X-20-02-X	2	12.7	5-20P	9.6	14-20P	10	14-20P	R449A	28
SPC/SIM-QSP-X-X-20-03-X	3	18.2	5-30P	12.0	14-20P	12.7	14-20P	R449A	40
SPC/SIM-QSP-X-X-20-04-X	4	23.7	5-30P	14.4	14-20P	15.5	14-20P	R449A	52

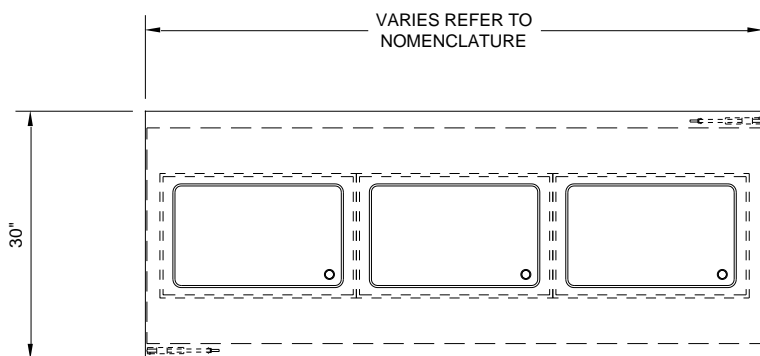

# SPC/SIM-QSP SLIM

PLAN

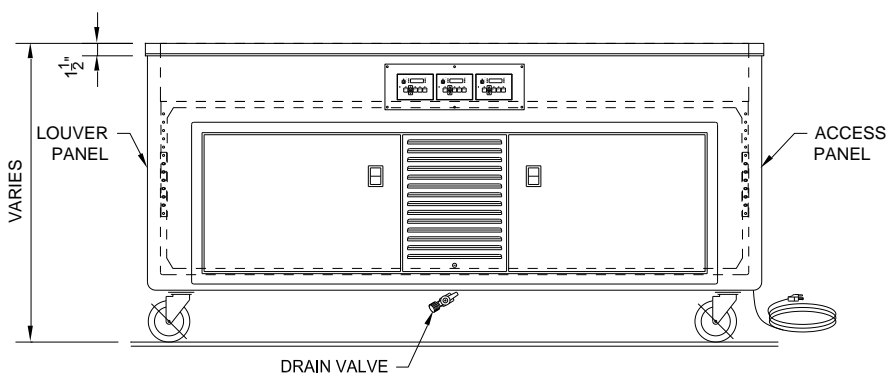

ELEVATION

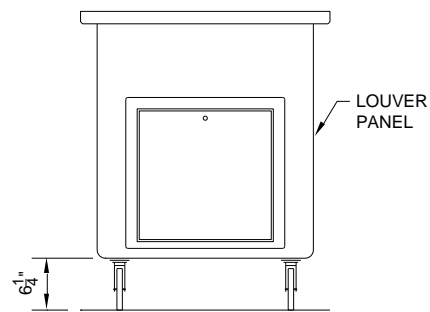

END ELEVATION

## SPC/SIM-QSP SLIM MODEL ELECTRICAL/REFRIGERANT INFORMATION

MODEL	PANS	120V/1/60HZ		120/208/1/60HZ		120/240/1/60HZ		REFRIGERANT	CHARGE OZ
		AMPS	PLUG	AMPS	PLUG	AMPS	PLUG		
DI-QSP-X-12-01-X	1	7.2	5-15P	7.2	14-20P	7.2	14-20P	R449A	16
DI-QSP-X-12-02-X	2	12.7	5-20P	9.6	14-20P	10	14-20P	R449A	28
DI-QSP-X-12-03-X	3	18.2	5-30P	12.0	14-20P	12.7	14-20P	R449A	40
DI-QSP-X-12-04-X	4	23.7	5-30P	14.4	14-20P	15.5	14-20P	R449A	52

# OPERATING INSTRUCTIONS

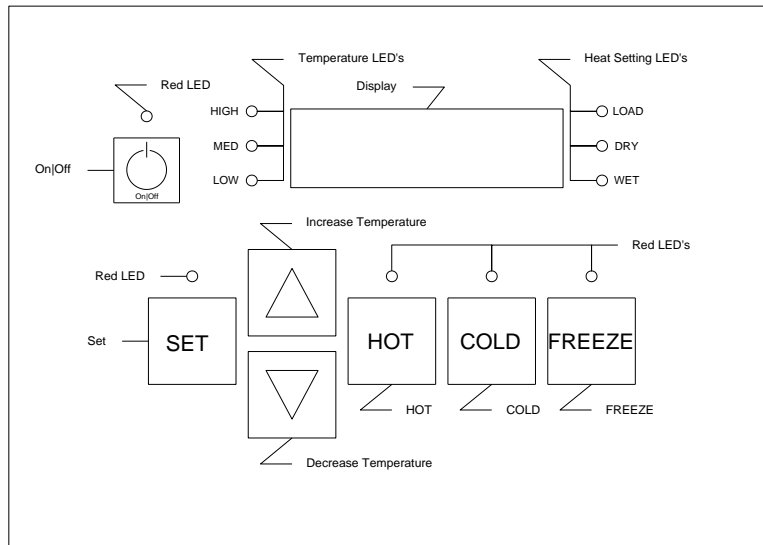

## Initial Setup/Guidelines:

**NEVER PUT ICE in the QSP wells when operating in the HOT, COLD, or FREEZE modes.** This can cause excessive condensation as well as poor inaccurate performance and error code issues when running the unit.

If ice is to be used place ice into a 6" deep standard 12 x 20 food pan and place that into the well opening. Ice placed directly in the pan forms condensation which over an extended period can damage the heating element.

- **HOT Wet/Dry Guidelines:**

- Pour one gallon of water or roughly a 1" of water into each well before turning on the unit.
- When changing from HOT to COLD, or ICE FREEZE, remove water from the well.
- The use of water for the dry heat setting is not necessary.
- Never pour water into a preheated dry well.
- Never place water in wells while using COLD or FREEZE modes.
- The well will heat immediately when changing from COLD or FREEZE to HOT.
- You must use a pan or lid over the well when preheating to reach the proper temperatures.
- Allow the well to preheat or cool for 45-60 minutes before using.

- **COLD / FREEZE Guideline:**

- Make sure to NEVER put ice directly into the QSP pan. If ice is used place the ice into a 6" deep standard 12x20 food pan and place it into the well opening.
- When going from HOT to the COLD or FREEZE setting the unit will NOT turn the condensing unit on until the temperature of the well is below 100°F. This will be indicated by the LOAD light flashing and once it is below 100°F the LOAD light will go solid, and the condensing unit will turn on.
- Allow the well to pre-cool for 45-60 minutes before using.

## Performance Issues:

If the unit is not performing in the HOT, COLD, or Freeze modes adjust the setpoints to a warmer or colder setting if possible. If P1, NC, or other error codes come up while running the unit in the HOT, COLD, or FREEZE mode or the unit is still not operating properly please see the troubleshooting section and/or contact LTI's Customer Service/Technical team, Tel: 1-888-584-2722 or our online warranty or chat at :

[LTI WARRANTY](#)

[LTI CHAT](#)

## Powering On the Unit

- Turn the unit on with the power switch (Master Switch) located on the right hand side of the bottom housing/frame.
- Once on, the Red LED light above ON|OFF will illuminate on each controller and OFF will appear on each screen.

## Turning on the HOT, COLD, FREEZE

- To turn on unit hold the ON|OFF key of each control for 3 seconds.
- On will be displayed on the controller.
- **Selecting HOT MODE**
  - Press and hold the HOT button for 3 seconds to use HOT Mode. H3 or the previous selected setting will be displayed.
- **Selecting COLD MODE**
  - Press and hold the COLD button for 3 seconds to use COLD Mode. C3 or the previous selected setting will be displayed.
- **Selecting FREEZE**
  - Press and hold the FREEZE button for 3 seconds to use FREEZE Mode. ICE will be displayed.

## Changing the Factory Settings

- If the well is running, press and hold the current active setting (HOT, COLD, OR FREEZE) indicated by the red LED above it for 3 seconds. ON will then be displayed.
- If the well is not running, make sure the unit is displaying ON.
- Next press the SET key for 3 seconds. Set will be displayed.
- Press the desired mode that you would like to change the setting on (HOT, COLD , FREEZE) for three seconds.
- Set the desired setting using the UP and DOWN ARROW keys
- Once you have it set, press and hold SET again and ON will appear.
- Now press the desired mode (HOT, COLD, FREEZE) for three seconds to continue operation.

## Temperatures of Hot, Cold, and Freeze

QUICKSWITCH SETTINGS AND TEMPERATURE RANGES		
HOT		
<u>SETTING</u>	<u>MODE</u>	<u>ELEMENT TEMP/TC TEMP</u>
H1	WET/LOW	250°F
H2	WET/MED	265°F
H3	WET/HIGH	290°F
H4	DRY/LOW	390°F
H5	DRY/MED	405°F
H6	DRY/HIGH	420°F
COLD		
<u>SETTING</u>	<u>MODE</u>	<u>ELEMENT TEMP/TC TEMP</u>
C1	LOW	30°F
C2	MED	33°F
C3	HIGH	38°F
FREEZE		
<u>SETTING</u>	<u>MODE</u>	<u>ELEMENT TEMP/TC TEMP</u>
FREEZE	LOWEST	10°F

### Powering Off the Unit

- Press and hold the ON|OFF button for 3 seconds on each well or turn the main power switch to the OFF position.

### Auto Setting on the Controllers

- Auto Restart Feature
  - The controllers can be pre-programmed for your next serving period ahead of time and will remember its settings for easy reuse.
  - Before you turn off the unit, set to the desired set points on the controllers for future use.
  - Next turn the power directly OFF from the Master Switch NOT the controllers themselves.
  - When you turn the Master Switch back to the ON position, “AUTO” will be displayed on the screen/screens of the controllers and will restart from the last set point that was selected.

## **CLEANING INSTRUCTIONS**

To maintain the performance and finish of the unit clean the unit daily. Make sure to use cleaning supplies and cleaners designed for cleaning stainless-steel surfaces.

### **Stainless steel:**

Use soft cloths, microfiber, sponges, or plastic scouring pads. Avoid using scrapers wire brushes, steel wool or anything that might scratch the surface. Always clean stainless-steel parallel with the “grain”. Use cleaners that contain alkaline, alkaline chlorinated, or non-chloride chemicals.

## **PREVENTATIVE MAINTENANCE**

To ensure that your equipment will continue to operate properly, please follow these simple steps:

1. The food wells should be cleaned thoroughly every day. Food spillage left in the pans such as tomato paste can cause damage to the unit. The acidic base of foods over time can cause pitting of the units.
2. Always wipe the unit down with a damp cloth and dry thoroughly. Do not spray water directly on the control panel areas or on areas with exposed heating elements.

## **TROUBLESHOOTING**

<b>COMPLAINT</b>	<b>PROBLEM</b>	<b>SOLUTION</b>
UNIT/WELL WILL NOT HEAT	PLUG DISCONNECTED	CHECK ALL ELECTRICAL CONNECTIONS
	LINE SWITCH OPEN	CLOSE SWITCH
	BREAKER TRIPPED	RESET BREAKER
	HEATER DEFECTIVE	REPLACE
	LOW VOLTAGE	USING INSTRUMENT CHECK LINE VOLTAGE AND AMPERAGE. VOLTAGE MUST BE WITHIN 10% OF NAME PLATE RATING
	OPEN RELAY ON CONTROLLER	CHECK THAT RELAY IS OPENING AND CLOSING PROPERLY. REPLACE IF NEEDED
CONTROLLER DISPLAYING INIT	TC NOT COMMUNICATING PROPERLY	CHECK CONNECTION POINTS OF THE TC TO THE CONTROLLER
	CONTROLLER NEEDS TO BE POLARIZED	RUN THROUGH POLARIZATION STEPS

	<b>PROBLEM</b>	<b>SOLUTION</b>
CONTROLLER DISPLAYING ER1	TC IS READING 0 VOLTS FOR 5 SECONDS WITH HEATERS ON	CHECK TC CONNECTIONS
	TC DISCONNECTED	CONNECT TC
CONTROLLER DISPLAYING ER2	AMBIENT TEMP ERROR (AMBIENT < 40°F OR AMBIENT > 130°F)	CHECK TC CONNECTIONS
CONTROLLER DISPLAYING ER4	DIP SWITCH POSITION CONFLICT	CHECK DIP SWITCH SETTING ON CONTROLLER SEE DIP SETTINGS SHEET PROVIDED
CONTROLLER DISPLAYING ER5	CONTROLLER NOT DETECTING SIGNAL FROM MOTHER BOARD	CHECK CONNECTION POINTS FROM CONTROLLER TO MOTHERBOARD
CONTROLLER DISPLAYING b1	INDICATES DETECTION OF A BACKWARDS THERMOCOUPLE CONNECTION IN HOT MODE (WHILE HEATING FROM COLD START UP 60 SEC)	ENSURE THERMOCOUPLE WIRES ARE ORIENTED CORRECTLY RED LEFT AS INDICATED BY LABEL
CONTROLLER DISPLAYING b2	INDICATES DETECTION OF A BACKWARD THERMOCOUPLE CONNECTION IN HOT MODE (WHILE HEATING 15 SEC)	ENSURE THERMOCOUPLE WIRES ARE ORIENTED CORRECTLY RED LEFT AS INDICATED BY LABEL
CONTROLLER DISPLAYING nc	INDICATES DETECTION OF THE SYSTEM NOT COOLING AND HAS REACHED THE 90min TIMEOUT	ENSURE THERMOCOUPLE IS PROPERLY CONNECTED CHECK TO MAKE SURE SOLENOID VALVE IS OPEN CHECK IF COMPRESSOR IS RUNNING CHECK REFRIGERATION CHARGE
CONTROLLER DISPLAYING p1	INDICATES THE PULSE MODE TIME LIMIT WAS EXCEEDED DURING START UP IN HOT MODE- UNIT DID NOT GET ABOVE 100°F WITHIN 5MIN OF START UP	ENSURE THERMOCOUPLE IS PROPERLY CONNECTED ENSURE HEATER IS ENERGIZED CHECK OHM READINGS ON HEATER 89-93ohms AT 208-240V 22ohms AT 120v
CONTROLLER DISPLAYING tc	INDICATES DETECTION OF AN OPEN THERMOCOUPLE	ENSURE THE THERMOCOUPLE IS PROPERLY CONNECTED OHM READINGS SHOULD BE 3-4ohms

<b>REFRIGERANT TROUBLESHOOTING</b>		
<b>COMPLIANT</b>	<b>PROBLEM</b>	<b>SOLUTION</b>
<b>COMPRESSOR WILL NOT START</b>	LINES DISCONNECTED / SWITCH OPEN	CLOSE START ON DISCONNECT SWITCH
	FUSE REMOVED OR BLOWN	REPLACE FUSE
	CONTROL STUCK IN OPEN POSITION	REPAIR OR REPLACE CONTROL
	CONTROL OFF DUE TO COLD LOCATION	RELOCATE CONTROL
<b>COMPRESSOR WILL NOT START, HUMS BUT TRIPS OVERLOAD PROTECTOR</b>	LOW VOLTAGE TO UNIT	CALL POWER SUPPLIER
	STARTING CAPACITOR DEFECTIVE	REPLACE CAPACITOR
	RELAY FAILING TO CLOSE	REPLACE RELAY
	COMPRESSOR MOTOR HAS A WINDING OPEN OR SHORTED	REPLACE COMPRESSOR
	INTERNAL MECHANICAL TROUBLE IN COMPRESSOR	REPLACE COMPRESSOR
<b>COMPRESSOR STARTS AND RUNS, BUT SHORT CYCLES ON OVERLOAD PROTECTOR</b>	LOW VOLTAGE TO UNIT	CALL POWER SUPPLIER
	OVERLOAD PROTECTOR DEFECTIVE	CHECK CURRENT, REPLACE PROTECTOR
	RUN CAPACITOR DEFECTIVE	REPLACE CAPACITOR
	EXCESSIVED DISCHARGE PRESSURE	CHECK VENTILATION, RESTRICTIONS IN COOLING MEDIUM, RESTRICTIONS IN REFRIGERANT SYSTEM
	COMPRESSOR TOO HOT, RETURN GAS HOT	CHECK REFRIGRANT CHARGE (FIX LEAK IF NECESSARY)
	COMPRESSOR MOTOR HAS A WINDING SHORTED	REPLACE COMPRESSOR
<b>UNIT RUNS OKAY, BUT SHORT CYCLE ON</b>	OVERLOAD PROTECTOR	CHECK CURRENT, REPLACE PROTECTOR
	THERMOSTAT	DIFFERENTIAL SET TO CLSE, WIDEN
	HIGH PRESSURE CUT OUT DUE TO: INSUFFICIENT AIR, OVERCHARGE, OR AIR IN SYSTEM	REDUCE REFRIGERANT CHARGE, PURGE. CHECK AIR SUPPLY TO CONDENSER, REDUCE REFRIGERANT CHARGE, PURGE
<b>UNIT OPERATES LONG OR CONTINUOUSLY</b>	SHORTAGE OF REFRIGERANT	FIX LEAK, ADD CHARGE
	CONTROL CONTACTS STUCK OR FROZEN/CLOSED	CLEAN CONTACTS, OR REPLACE CONTROL
	REFRIGERANT OR AIR CONDITIONED SPACE HAS EXCESSIVE LOAD OR POOR INSULATION	DETERMINE FAULT AND CORRECT
	EVAPORATOR COIL ICED	DEFROST
	RESTRICTION IN REFRIGERANT SYSTEM	DETERMINE LOCATION AND REMOVE
	DIRTY CONDENSER	CLEAN CONDENSER
	FILTER DIRTY	CLEAN OR REPLACE
<b>START CAPACITOR OPEN</b>	RELAY CONTACTS NOT OPENING PROPERLY	CLEAN CONTACTS OR REPLACE IF NECESSARY
	PROLONGED OPERATION ON CYCLE DUE TO LOW VOLTAGE, IMPROPER RELAY	CALL POWER SUPPLIER, OR REPLACE
<b>RUN CAPACITOR OPEN, SHORTED OR BLOWN</b>	EXCESSIVE SHORT CYCLE	DETERMINE REASON FOR SHORT CYCLE
	IMPROPER CAPACITOR	DETERMINE CORRECT SIZE AND REPLACE
	EXCESSIVELY HIGH LINE (100% OF RATED-MAX)	CALL POWER SUPPLIER
<b>SPACE TEMPERATURE TOO HIGH</b>	CONTROL SETTING TO HIGH	RESET CONTROL
	INADEQUATE AIR CIRCULATION	IMPROVE AIR MOVEMENT
<b>SUCTION LINE FROSTED OR SWEATING</b>	EXPANSION VALVE STUCK	CLEAN VALVE OFF FOREIGN PARTICLES, REPLACE IF NECESSARY
	EVAPORATOR FAN NOT RUNNING	DETERMINE REASON AND CORRECT
	OVERCHARGE OF REFRIGERANT	CORRECT CHARGE

## REPLACEMENT PARTS

ITEM NO.	DESCRIPTION	STOCK NO.	MFG NO.	MANUFACTURER
1	CONDENSING UNIT	311937	AE2420-AA1BXM (BOM-2E294-1)	TECUMSEH
1A	CONDENSING UNIT	311935	AE2415Z-AA1ASC (BOM-32F328-59S)	TECUMSEH
2	COMPRESSOR AE2420Z-DS1B	311982	AE1322E-679-J7	TECUMSEH
2A	COMPRESSOR AE2415-AA1A	311983	BM AE1157E-679-J7	TECUMSEH
3	COMPRESSOR	311999	AFE14C5E-CA (OLD-AFE13C3-IAA-901)	COPELAND
4	PRESSURE CONTROL	280610	012-4834-000	RANCO
5	DIGITAL PRESSURE CONTROL	311938	TECUMSEH P/N-900-11968	DIXELL
6	FILTER DRIER	282310	C-052-S-T-HH	SPORLAN
7	SIGHT GLASS	282400	SA-12S	SPORLAN
8	ACCUMULATOR	281710	060819 (A-AS384)	EMERSON
8A	ACCUMULATOR	311810	102-10034	TECUMSEH
9	TXV-R507	282572	Y1017-FP-1/6ZP R507A	SPORLAN
9A	TXV-R449	282586	EXP.VALVE(1/2x1/4ODF)/R- 449-ZP	SPORLAN
9B	TXV-R449 5' LEAD	282587	EXP.VALVE(1/2x1/4ODF)/R- 449-ZP - 5' CAP	SPORLAN
10	LIQUID LINE SOLENOID	281610	E3S120W	SPORLAN
11	QUICKSWITCH WELL	MF310029RZ	CHP-PAN	LTI
12	ROCKER SWITCH 2PL- 20A/277V	335917	TIGK721-6S-BL-NBL- 20A/277V	CARLING
13	35A RELAY	515855	20844-84	DELTRON
14	QUICKSWITCH CONTROLLER	195446	330-HMI-QS-001	330 ELEC.
15	SINGLE MOTHERBOARD	195448	330-MB-001	330 ELEC.
16	DOUBLE MOTHERBOARD	195449	330-MB-002	330 ELEC.
17	HEATER/PLATE ASSEMBLY 72" LEAD	190010	LT0815SA	THERMO

## **INIT INSTRUCTIONS**

### **KEYPAD INSTALLATION PROCEDURES**

**Purpose:** A newly installed keypad will display INIT. This is a factory setting which assures the temperature sensor is properly connected.

**Caution:** The LTI food well is equipped with a high wattage heating element. This procedure asks for HOT WATER to be added as a precaution to protect the heating element from overheating during initialization.

**Caution:** For installations in multiple food well equipment, this procedure presumes the keypad is properly configured and wired for its corresponding food well. For QuickSwitch keypads, see DIP switch settings procedure.

**Note:** The use of HOT WATER in this procedure will help the keypad more quickly recognize the polarity of the temperature sensor connection.

**Step 1:** Add enough HOT WATER to the food well to fully cover the bottom.

**Step 2:** Turn ON power. **Step 3:** Press the UP key five times quickly. For 30 seconds, the display will alternate “PoLr” and temperature while it is trying to detect sensor polarity.

**Step 3:** Verify the correct well is heating.

**Step 4:** After the keypad detects the proper polarity of the temperature sensor connection, “OFF” will be displayed.

**Step 5:** If the display returns to “INIT” go back to step 3. It may be necessary to do this three or four times.

If you have questions, please contact LTI’s Customer Support for help at 1-888-584-2722 or online at <https://lowtempind.com/contact-us/>

## DIP SWITCH SETTINGS

### INSTALLATION INSTRUCTIONS QUICKSWITCH CONTROL FOOD WELL NUMBER DIP SWITCH SETTINGS

Before installing each QuickSwitch controller the *Food Well Number* must be set. The system uses the food well number setting to correlate with the food well it controls. The DIP switch on the back of the circuit board is used to assign the food well number.

All controllers are set at the factory as food well 1. Refer to the illustrations below to assign the food well number. Using a small screw driver carefully slide each switch to the proper position.

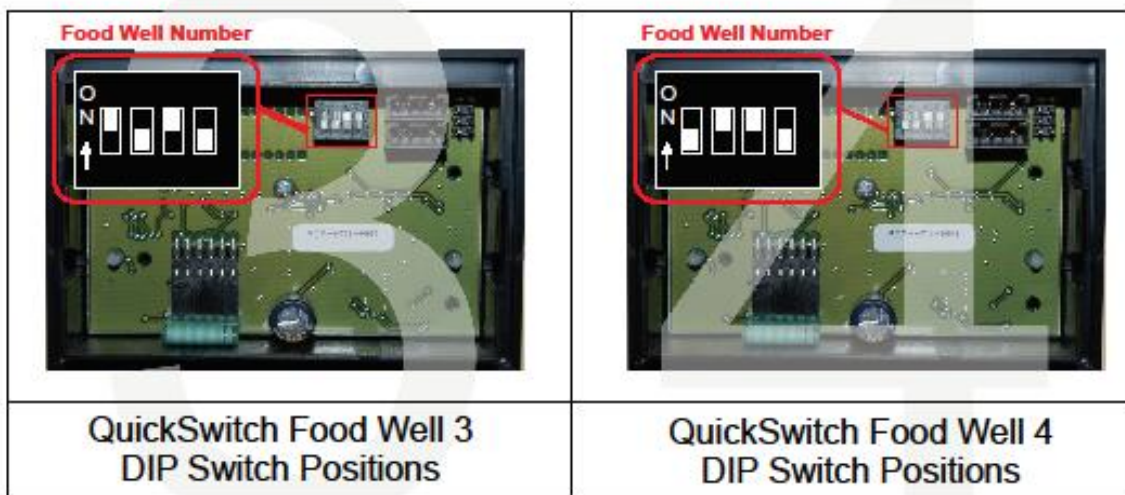
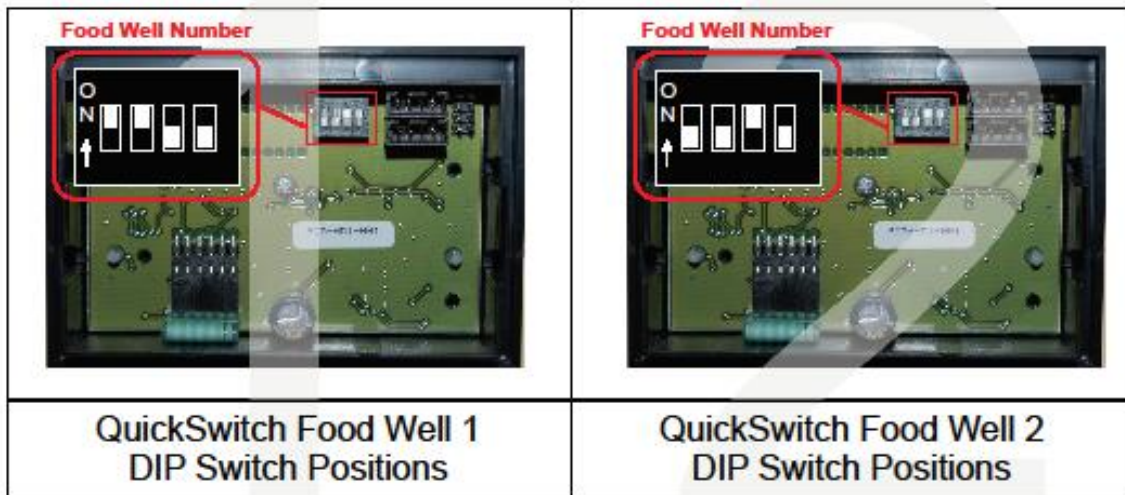

**WIRING DIAGRAMS**

**QSP-1  
120V**

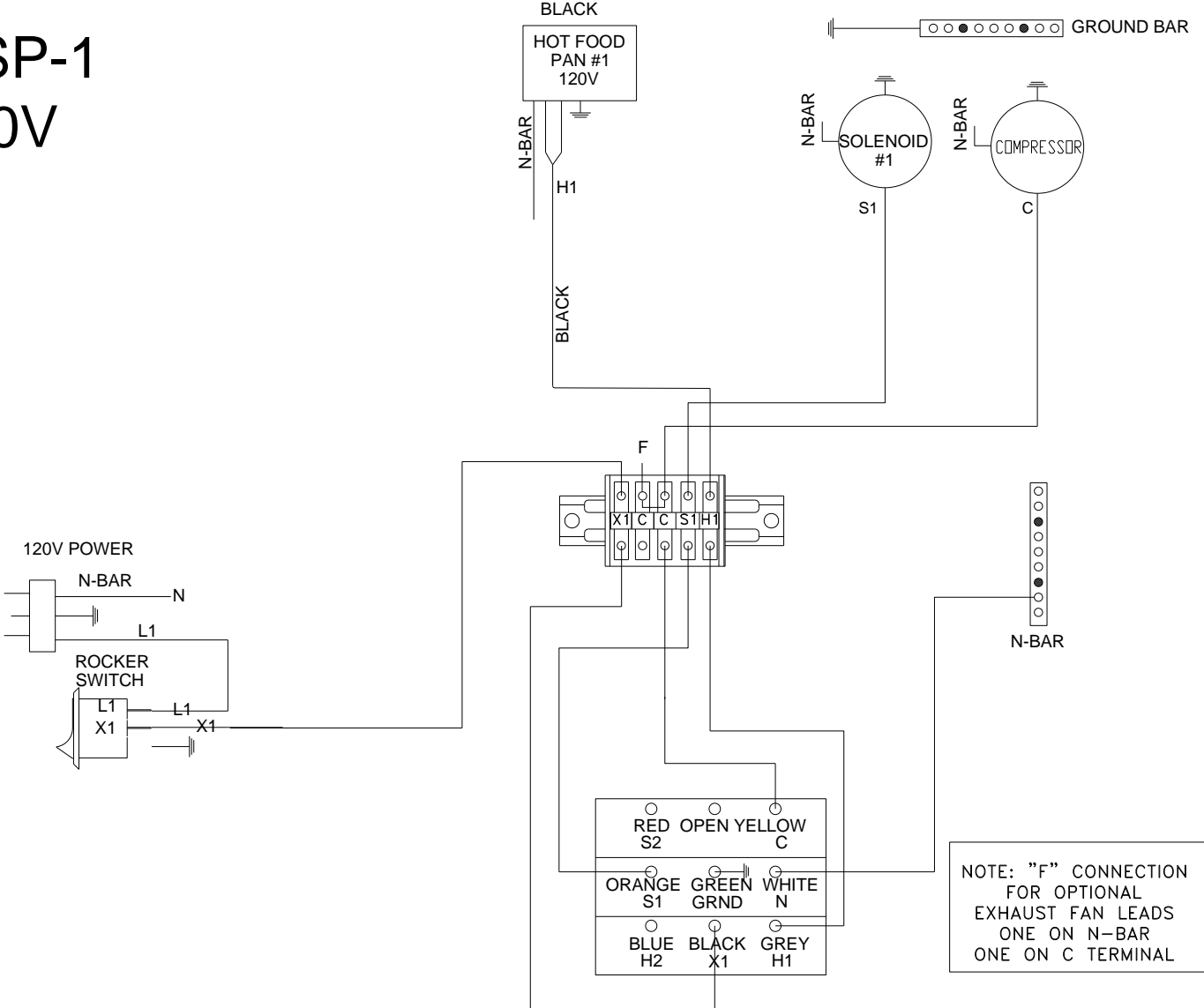

# QSP-1 120/208V

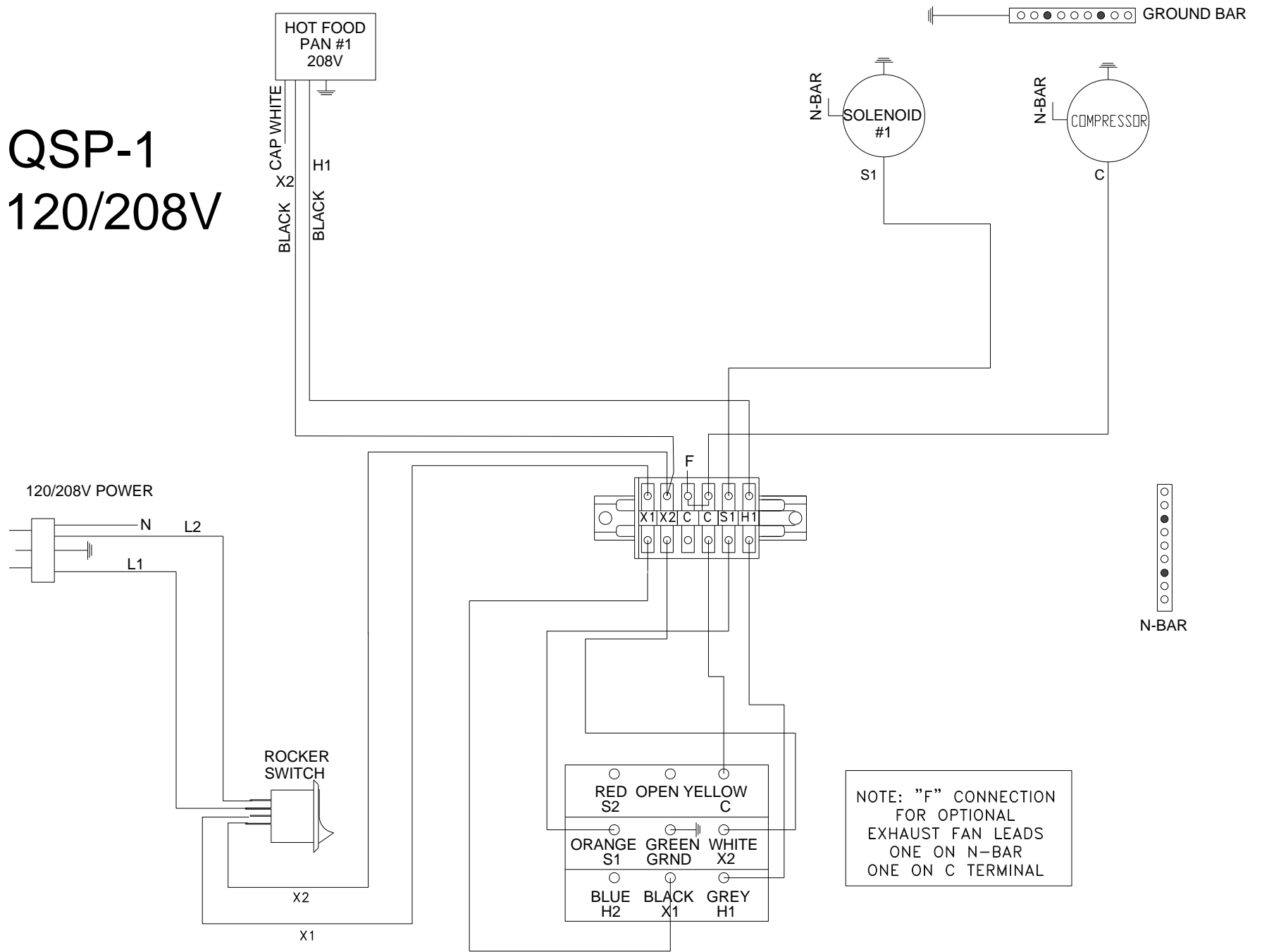

# QSP-2 120V

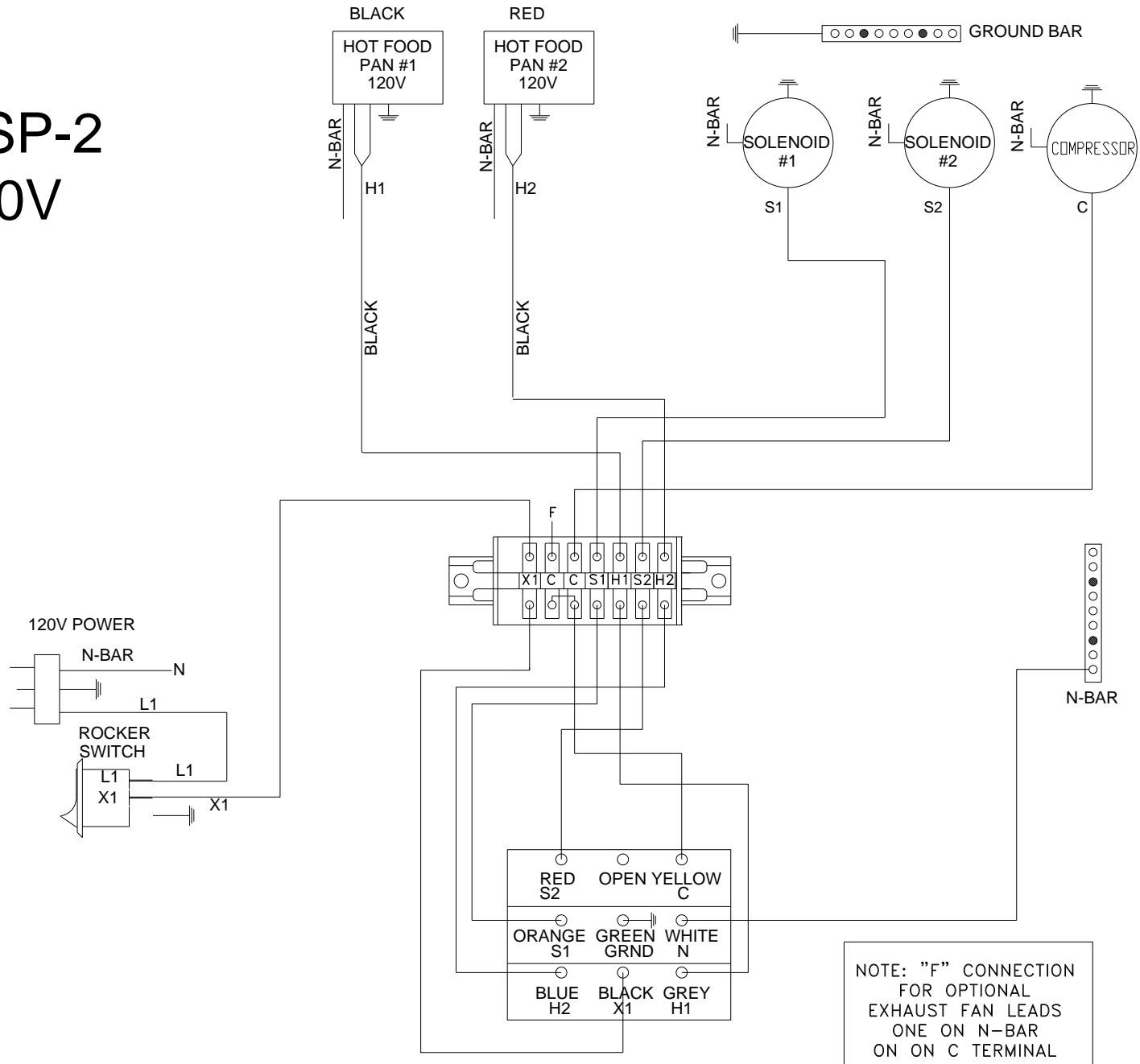

# QSP-2 120/208V

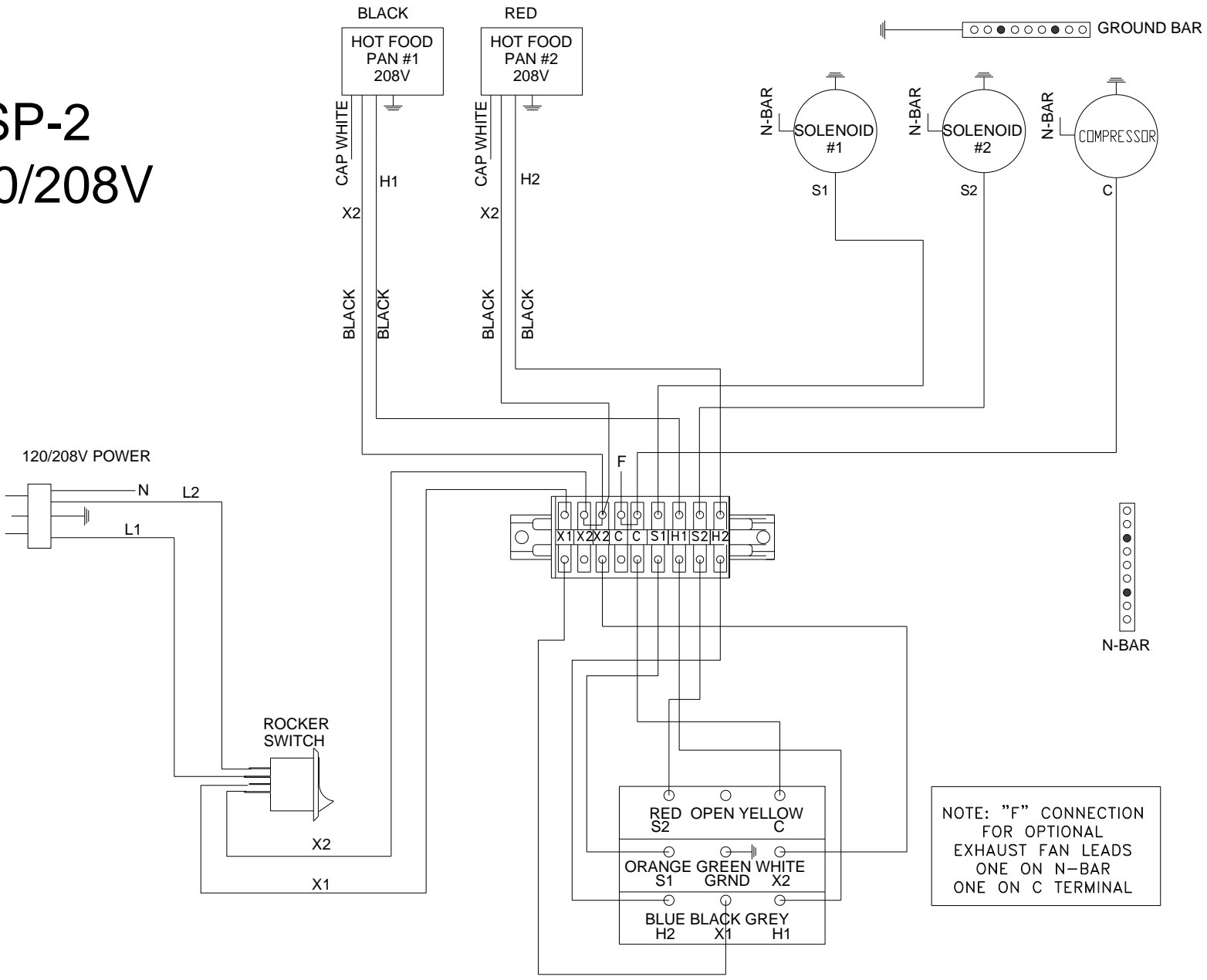

# QSP-3 120/208V

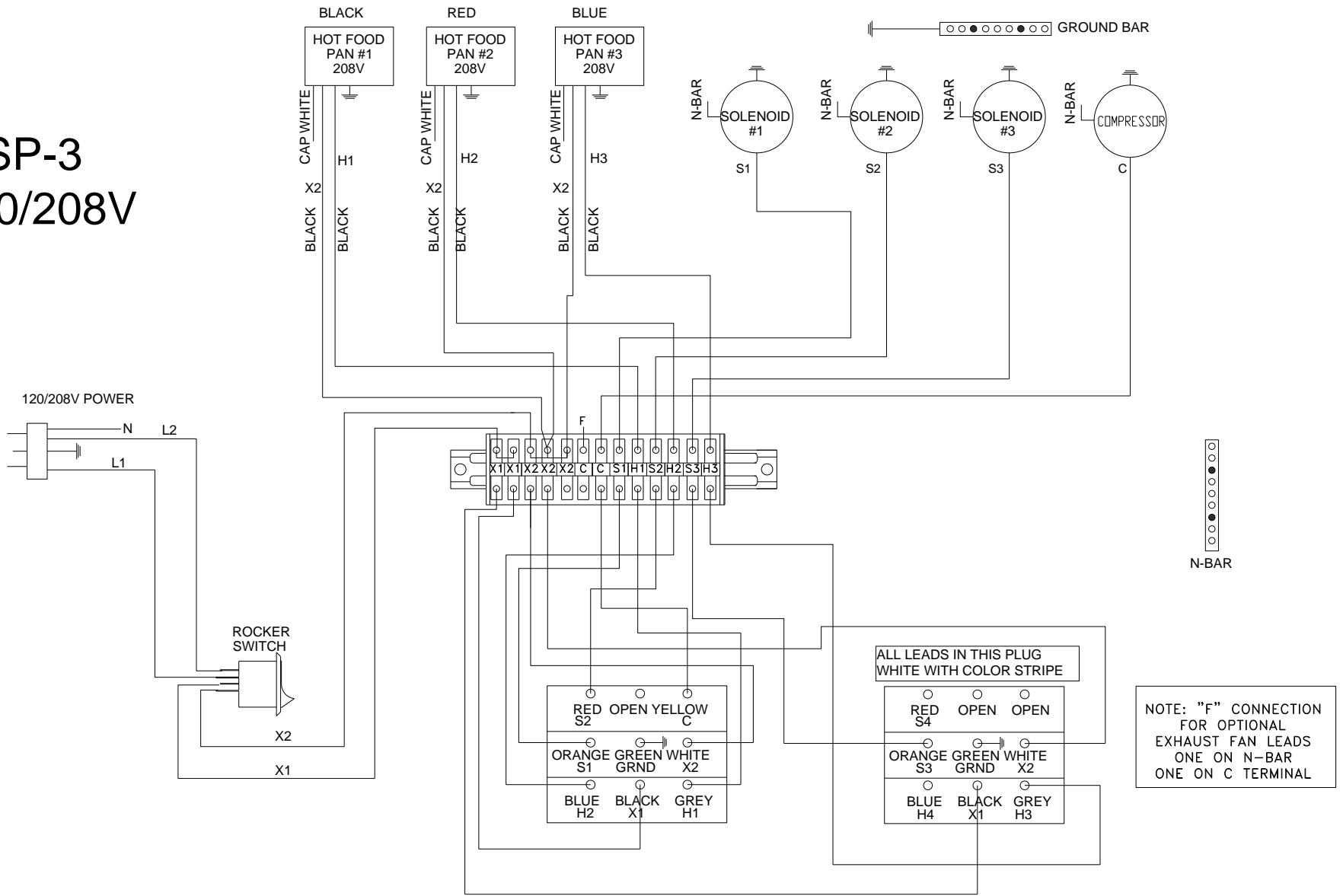

# QSP-3 120V

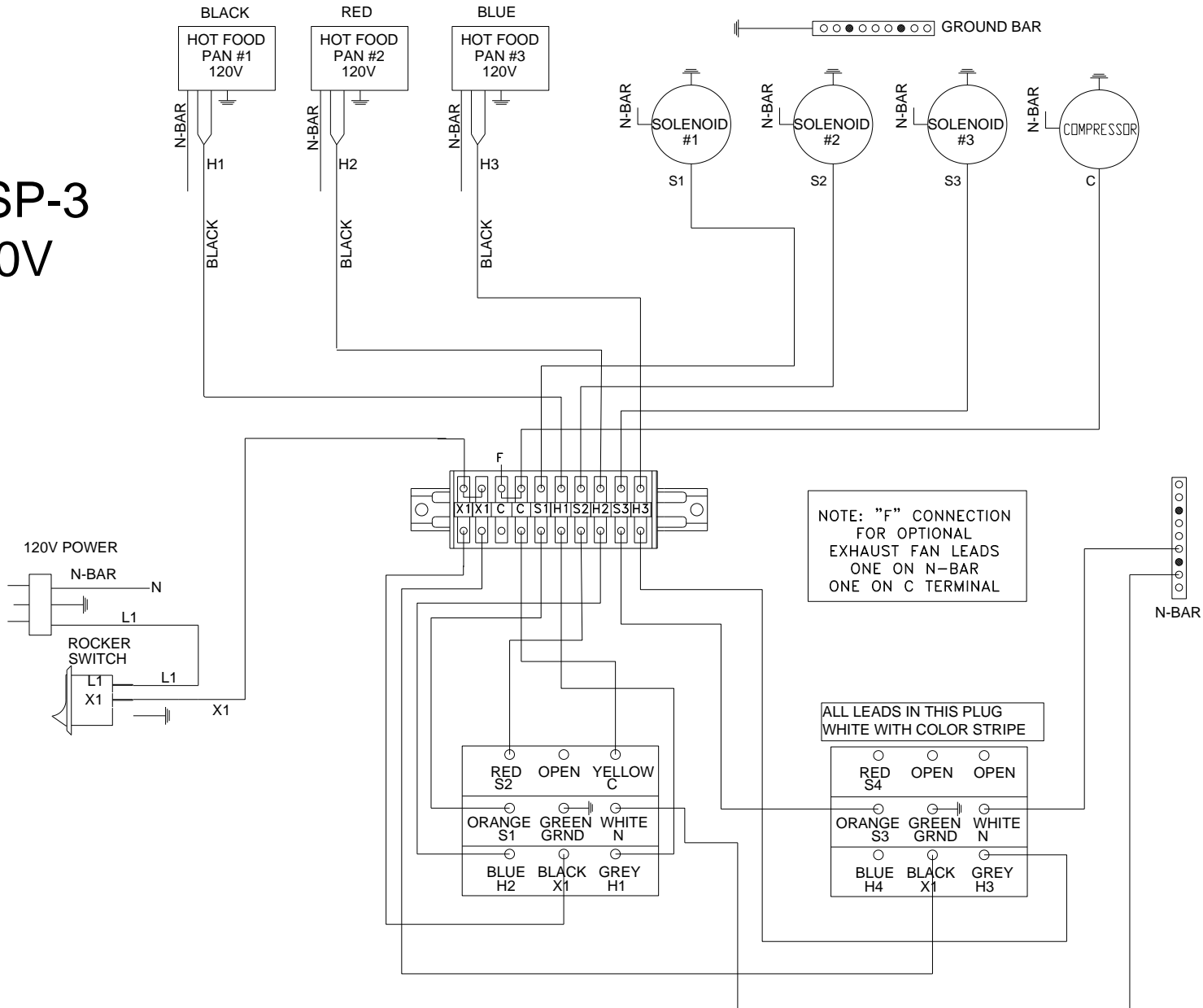

# QSP-4 120/208V

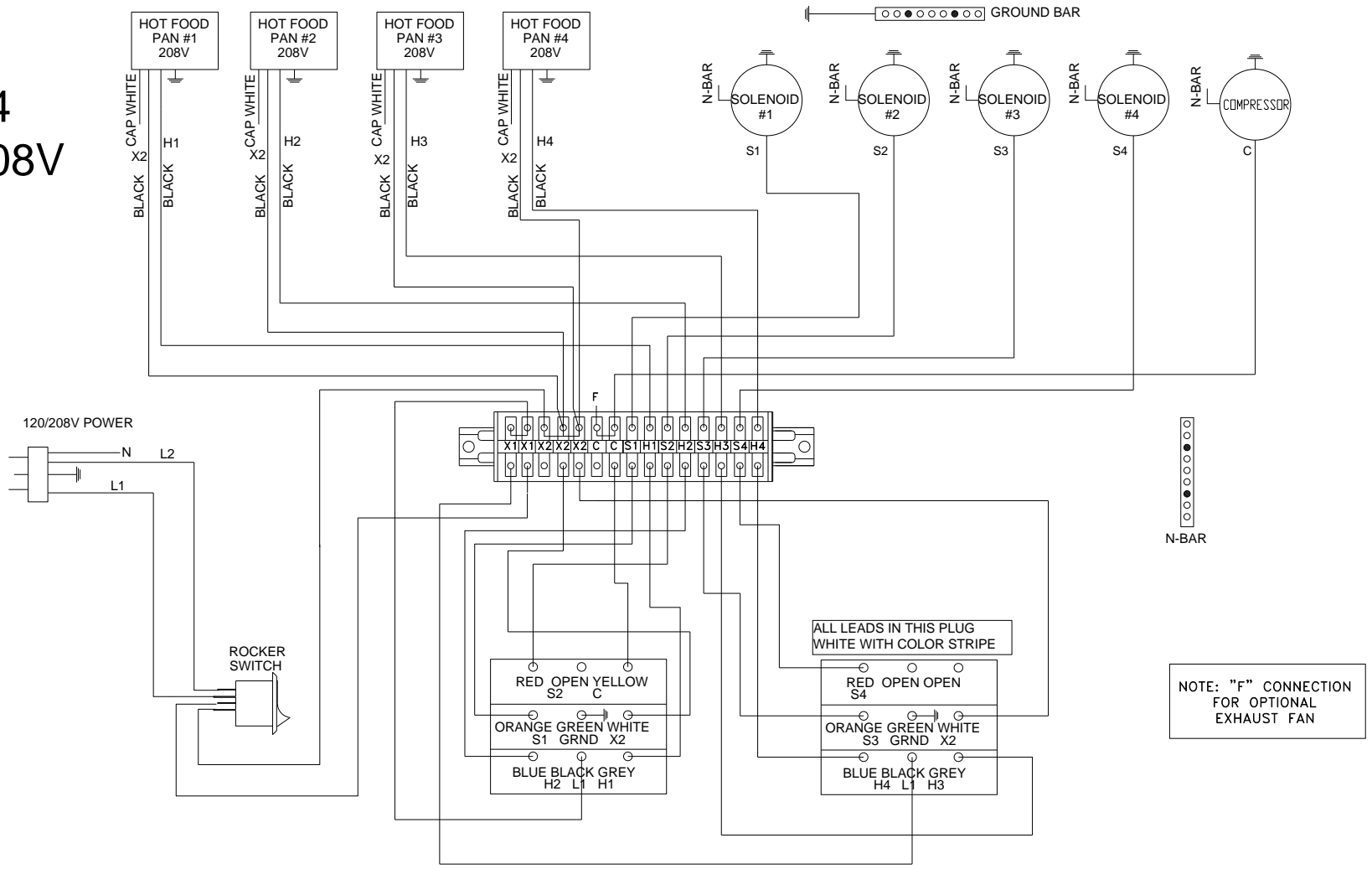

# QSP-4 120V

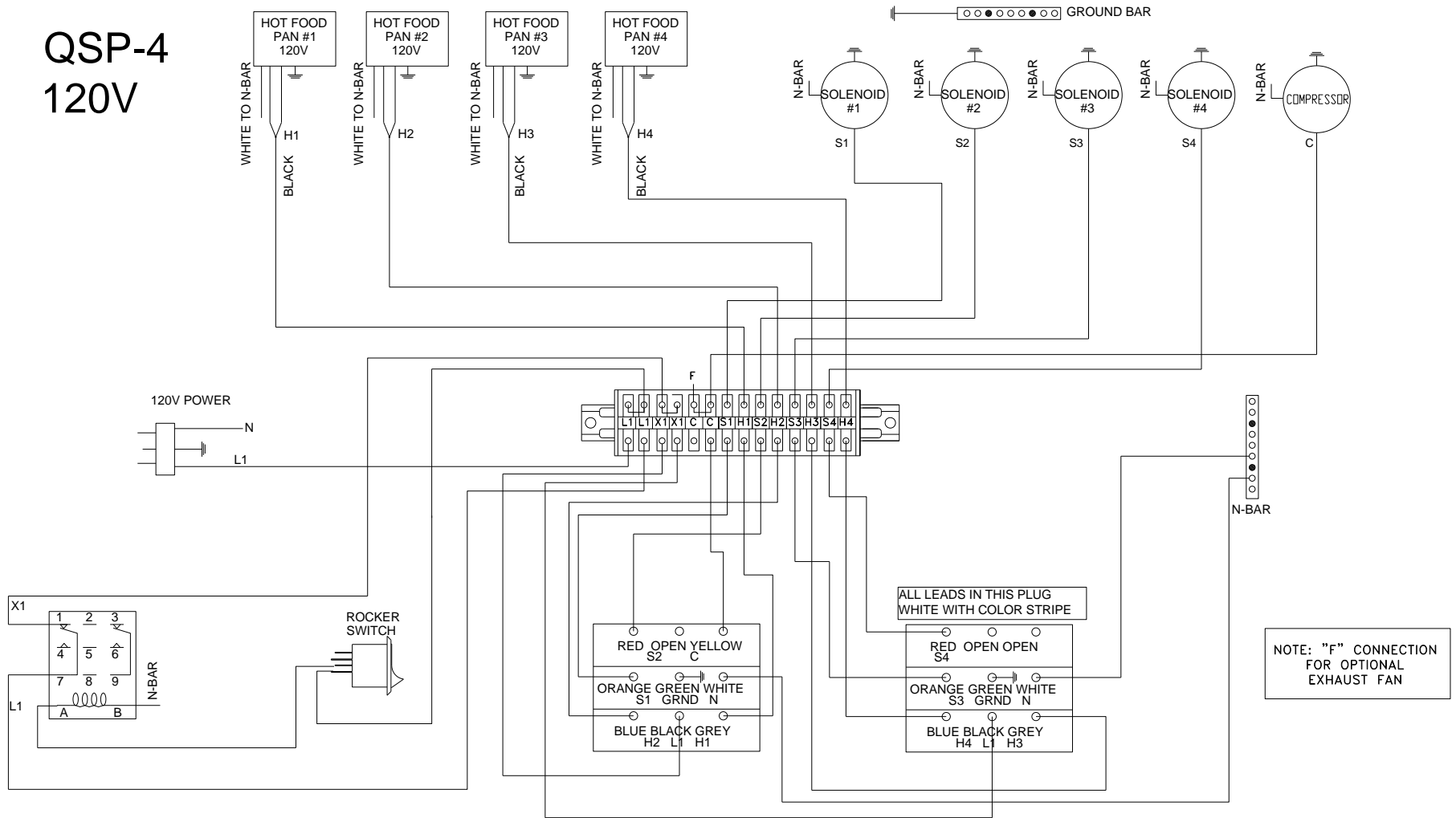

## **WARRANTY**

Effective date July 1<sup>st</sup>, 2020

The LTI parts and labor warranty for all products is (1) year for all products (some product families have total of two-year parts and labor); The warranty period commences with the date of installation, or six (6) months from date of shipment from the factory, whichever is sooner. Refrigeration compressors come standard with a 5-year compressor warranty. The warranty covers all products used in United State and Canada. All labor and parts expense after the expiration of the warranty shall be the responsibility of the owner.

The QuickSwitch Family, TempestAir and ThermalWell families all include a 2yr parts and labor warranty.

K-12 warranty is 2 years parts and labor on ALL equipment.

All warranty labor is to be pre-authorized by the factory. To request warranty please go to <https://lowtempind.com/resources/warranty/> or call 888-584-2722 for pre-authorization and ask for the warranty department.

The warranty includes travel time to portal, not to exceed 100 miles round trip, or two hours total travel time. The warranty requires that all labor must be performed during regular work hours. Overtime premiums will be charged to the owner or must be pre-approved prior to the service call. The warranty does not apply to any equipment or component parts which have been subjected to shipping damage, improper voltage, improper installation, alteration, abuse, or misuse. The warranty does not cover routine maintenance activities, any failure that results from lack of, or improper equipment maintenance activities. The warranty does not cover any loss of business profits, any loss of food, or other products, or damage to property due to electrical, gas or mechanical malfunction or to any incidental or consequential damages of Purchaser or any third party. Damage due to floods, fire or other acts of God also are not covered.

Due to the custom nature of the products returns are not allowed. All inquiries concerning this warranty must be directed to LTI.

**LTI**

**1947 Bill Casey Parkway • Jonesboro, GA 30236**

**Tel: 1-888-584-2722 • Fax: 1 (770)-471-3715**

**www.lowtempind.com**