

# **OPERATIONS AND MAINTENANCE MANUAL REPLACEMENT PARTS LIST FOR:**



**PD SERIES  
PORTABLE PLATE DISPENSER**

**PW SERIES  
PORTABLE HEATED  
PLATE DISPENSER**

**TD SERIES  
PORTABLE TRAY DISPENSER**

**TW SERIES  
PORTABLE HEATED  
TRAY DISPENSER**

**CPM SERIES  
PORTABLE TUBULAR  
DISPENSERS AND TRAY STANDS**

**CDS SERIES  
PORTABLE DISH CARTS**

## **INTRODUCTION**

THIS MANUAL HAS BEEN COMBINED TO INCLUDE A NUMBER OF DIFFERENT MODELS. ALL OF THESE MODELS ARE CLASSIFIED AS PORTABLE DISPENSERS AND MOST CAN BE PURCHASED WITH A NUMBER OF DIFFERENT ELECTRICAL OPTIONS. WHEN REFERENCING THE ELECTRICAL DIAGRAM INCLUDED, PLEASE CHECK YOUR SPECIFIC UNIT FOR THOSE OPTIONS WHICH WERE INCLUDED. DISREGARD THOSE OPTIONS THAT ARE NOT APPLICABLE TO YOUR SPECIFIC UNIT. THE FUSING OF CIRCUITS MAY VARY FROM THE DIAGRAM DEPENDING UPON THE NUMBER OF ELECTRICAL DEVICES PROVIDED AND THE SIZE OF THE ELECTRICAL SERVICE REQUIRED.

## **INSPECTION**

UPON RECEIPT, THE CRATE SHOULD BE INSPECTED FOR VISUAL DAMAGE. ANY DAMAGE SHOULD BE REPORTED IMMEDIATELY TO THE CARRIER.

## **INSTALLATION INSTRUCTIONS**

THESE COLORPOINT UNITS ARE COMPLETELY SELF CONTAINED AND SHIPPED READY FOR INSTALLATION. ALL UNITS COME COMPLETELY PREWIRED INCLUDING ELECTRICAL OPTIONS, READY FOR CONNECTION TO THE PROPER POWER SUPPLY.

IF LINE UP LOCKS ARE PROVIDED, SIMPLY ALIGN THE UNITS AND PUSH THE BARREL BOLTS THROUGH THE KEY HOLE SLOTS ON BOTH UNITS THEN TURN THE BOLT DOWN AND PUSH UP THE CAM LOCKING LEVER. TO UNLOCK THE UNITS, REVERSE THIS PROCEDURE.

## **OPERATING INSTRUCTIONS**

THE COLORPOINT SERIES IS DESIGNED FOR MODULAR OPERATION. THESE UNITS ARE DESIGNED TO BE ALIGNED END TO END AND LOCKED TOGETHER TO FORM A CONTINUOUS SERVING LINE, OR MAY BE USED FREE STANDING.

THE EXTENSION SPRINGS PROVIDED WITH THE LOWERATOR SYSTEMS MAY NEED ADJUSTING DEPENDING UPON THE TYPE AND SIZE OF THE TRAY USED. SEE THE SECTION ON HOW TO ADJUST THE SPRINGS LATER IN THIS MANUAL.

## **CLEANING**

THE TOP AND INTERIOR SURFACES OF THIS EQUIPMENT IS MANUFACTURED FROM STAINLESS STEEL. PLEASE REFER TO THE FOLLOWING SECTION CALLED "HOW TO CLEAN STAINLESS STEEL" FOR CLEANING INSTRUCTIONS.

THE EXTERIOR BODY IS MANUFACTURED FROM FIBERGLASS. SEE THE FOLLOWING SECTION TITLED "FIBERGLASS BODY" FOR CLEANING INSTRUCTIONS.

THE BREATH PROTECTORS ARE MANUFACTURED FROM PLEXIGLASS. SEE THE FOLLOWING SECTION TITLED "PLEXIGLASS SHIELDS" FOR CLEANING INSTRUCTIONS.

**FIBERGLASS BODY:**

THE FIBERGLASS BODY SHOULD BE CLEANED WITH A MILD NON-ABRASIVE CLEANER AND A SOFT CLOTH.

**\*\*\* CAUTION \*\*\***

**DO NOT USE BLEACHES, ABRASIVE CLEANERS OR ABRASIVE CLOTHS OR PADS AS THEY MAY DISCOLOR AND SCRATCH THE FIBERGLASS. DO NOT USE HARSH CHEMICALS, ACIDS OR ALKALIS IN THE CLEANING OF THE FIBERGLASS.**

**PLEXIGLASS SHIELDS:**

USE A MILD SOAP AND A SOFT CLOTH WHEN CLEANING THE PLEXIGLASS SURFACES. WIPING THE SURFACE WITH A DRY CLOTH CAN CAUSE SCRATCHES.

**DO NOT USE WINDOW CLEANING SPRAY OR KITCHEN SCOURING COMPOUNDS. PRODUCTS WITH A HIGH ALCOHOL CONTENT CAN CAUSE SURFACE FISSURES COMMONLY REFERRED TO AS "CRAZING". THIS WILL OCCUR IN ANY SPOT THAT HAS BEEN SUBJECT TO STRESSES, SUCH AS CHIPPED OR BURNED SAW CUTS, CRACKED HOLES FLAME POLISHED EDGES, FORMED EDGES, ETC.**

**\*\*\* WARNING \*\*\***

**IN ORDER TO PREVENT ANY ELECTRICAL ACCIDENTS, THIS EQUIPMENT SHOULD BE INSTALLED AND SERVICED BY QUALIFIED MAINTENANCE PERSONNEL ONLY PER NATIONAL ELECTRICAL CODE STANDARDS.**

**VARIOUS OPTIONS MAY BE PURCHASED WITH THIS EQUIPMENT. WHEN THESE OPTIONS ARE PROVIDED THE ELECTRICAL CIRCUITS MAY BE SEPARATELY FUSED WITH CLASS "G" FUSES. IF FUSES MUST BE REPLACED REPLACE WITH THE SAME TYPE AND AMPERAGE FUSE.**

## HOW TO CLEAN STAINLESS STEEL

THE FOLLOWING INFORMATION WAS TAKEN FROM A PAMPHLET BY MR. RICHARD E. PARET, STAINLESS STEEL SPECIALIST, AMERICAN IRON AND STEEL INSTITUTE.

STAINLESS STEEL IS ONE OF THE EASIEST MATERIALS TO CLEAN AND KEEP CLEAN.

THE REASONS FOR STAINLESS STEEL'S EASE OF CLEANING ARE EASY TO SEE; THEY LIE IN THE NATURE OF THE METAL ITSELF.

1. ITS HARD, TOUGH SURFACE. STAINLESS STEEL WILL WORK HARDER, THAT IS, THE MORE IT IS USED, THE MORE RESISTANT TO WEAR IT BECOMES. STAINLESS STEEL WILL NOT DEVELOP ROUGH SPOTS THAT HARBOR BACTERIA AND SOIL.
2. HIGH CORROSIVE RESISTANCE. STAINLESS STEEL IS PRACTICALLY UNTOUCHED BY THE CORROSIVE ATTACKS OF MOISTURE, DETERGENTS, FOOD ACIDS, BLOOD, SALTS AND OTHER CORRODENTS CONNECTED WITH FOOD PREPARATION. THIS MEANS THAT STAINLESS STEEL ALWAYS HAS A BRIGHT SURFACE FREE FROM OXIDES THAT CAN AFFECT THE FLAVOR OF FOODS.

THE SECRET OF MAINTAINING STAINLESS STEEL IS FREQUENT, SCHEDULED CLEANING THAT WILL PREVENT BUILD UP OF SURFACE DEPOSITS. SURFACE DEPOSITS, IF ALLOWED TO REMAIN FOR LONG PERIODS OF TIME CAN HARM STAINLESS STEEL. STAINLESS STEEL THRIVES ON EXPOSURE TO AIR; UNDER CERTAIN CONDITIONS, THE LENGTHY DEPRIVATION OF OXYGEN BY HEAVY SOIL DEPOSITS CAN CAUSE LOCALIZED PITTING OR STAINING.

NEGLECTING THE MATERIAL IN THIS MANNER IS **DEFINITE ABUSE** WHICH EVEN STAINLESS STEEL IS NOT IMMUNE.

TWO BASIC RULES:

1. CLEAN FREQUENTLY, AND ON A FIXED SCHEDULE.
2. SELECT THE SIMPLEST METHOD.

TO REMOVE ORDINARY DIRT AND FOOD RESIDUE FROM STAINLESS STEEL EQUIPMENT THAT OPERATES AT LOW TEMPERATURES, USE ORDINARY SOAP AND WATER AND APPLY WITH A SPONGE, FIBER BRUSH OR CLOTH. TO HASTEN ACTION, ADD EITHER SODA ASH, BAKING SODA, BORAX OR ANY OF SEVERAL NON-ABRASIVE COMMERCIAL CLEANSING AGENTS.

TO REMOVE SPLATTER OR CONDENSED VAPOR WHICH HAVE "BAKED" ONTO THE EQUIPMENT, THE TREATMENT OUTLINED ABOVE IS OFTEN SUFFICIENT. IN OTHER CASES A GENTLE TO VIGOROUS POLISHING ACTION MAY BE NECESSARY.

FIRST TRY A PASTE MADE WITH WATER AND AMMONIA AS THE LIQUID AND EITHER MAGNESIUM OXIDE, FINELY POWDER PUMICE OR FRENCH CHALK AS THE SOLID. YOU CAN ALSO USE ONE OF SEVERAL COMMERCIAL CLEANERS LISTED IN THE FOLLOWING TABLE.

RUB AS GENTLY AS POSSIBLE IN THE DIRECTION OF THE POLISHING MARKS ON THE STEEL, USING A SOFT CLOTH. FOR MORE RESISTANT DEPOSITS, USE A STAINLESS STEEL SCOURING SPONGE OR STAINLESS STEEL WOOL OF THE FINEST POSSIBLE TEXTURE.

**WHAT NOT TO DO:**

DO NOT USE COMMON STEEL WOOL, SCOURING PADS, SCRAPERS, WIRE BRUSHES, FILES OR OTHER STEEL TOOLS, SINCE THESE CAN MAR THE STAINLESS STEEL. THESE PARTICLES WILL EVENTUALLY RUST AND STAIN THE SURFACE, AND YOU MAY HAVE TO REFINISH IT.

**HOW TO CLEAN STAINLESS STEEL**  
**(CONT.)**

SLIGHTLY DARKENED AREAS SOMETIMES APPEAR ON STAINLESS STEEL SURFACES WHERE HEAT HAS BEEN APPLIED DURING FABRICATION OR IN SERVICE.

THESE ARE CAUSED BY THICKENING OF THE PROTECTIVE SURFACE OF STAINLESS STEEL, AND ARE NOT HARMFUL. REMOVAL CALLS FOR ENERGETIC SCOURING, AGAIN USING A STAINLESS STEEL WOOL OR SCOURING PAD, COMBINED WITH A SCOURING POWDER OR ONE OF THE HEAT-TINT REMOVERS LISTED IN THE TABLE.

THREE RULES WILL PREVENT HEAT TINTING:

- 1) USE ONLY ENOUGH HEAT TO DO THE JOB EFFICIENTLY.
- 2) DO NOT APPLY HEAT TO EMPTY EQUIPMENT.
- 3) AVOID CONCENTRATING HEAT ON A SMALL AREA.

**\*\*\* CAUTION IS ADVISED \*\*\***

IN STERILIZING STAINLESS STEEL EQUIPMENT, PAY PARTICULAR ATTENTION TO AGENTS CONTAINING CHLORINE COMPOUNDS SUCH AS POTASSIUM HYPOCHLORITE. THESE COMPOUNDS MAY BREAK DOWN AND RELEASE FREE CHLORINE, OR HYDROLYZE TO FORM HYDROCHLORIC ACID.

STAINLESS STEEL RESISTS ATTACK BY SUCH COMPOUNDS FOR UP TO TWO HOURS. SEVERE LOCALIZED PITTING MAY OCCUR FROM LONGER EXPOSURE. FOR SAFE USE OF THESE AGENTS, KEEP CONTACT TIME SHORT, FLUSH THOROUGHLY WITH WATER, AND OPERATE EQUIPMENT NORMALLY BETWEEN APPLICATIONS. USING THESE PRECAUTIONS, THE STERILIZATION PROCESS CAN BE REPEATED ANY NUMBER OF TIMES.

## CLEANERS AND THEIR EFFECT ON STAINLESS STEEL

Cleaning agent	Method of Application	Effect on Finish
1. Tightly adhering deposits of "baked on" spatter, oil, grease, weather stain, dyes or other light discoloration may be removed with any of the following cleaners.		
Grade FFF Italian pumice whitening or bon ami pressure on no.7	scour or rub with damp cloth	satisfactory for all finishes use light
Liquid NuSteel	scour with small amount on dry cloth	satisfactory for all finishes if rubbing pressure is light
Paste NuSteel or Temp	scour with small amount on dry cloth	satisfactory for no. 4 finish. Will scratch no.7
House hold cleaners such as Old Dutch, Sunbrite, Wyandotte, Bob-O, Gold Dust and Sapolio	Rub with damp cloth	Will scratch no. 4 finish slightly
Grade F Italian Pumice	Rub with damp cloth	Will scratch no.4 finish slightly
Cooper's stainless steel polish for no.4	satisfactory	Rub with damp cloth finish
Allen stainless steel polish	Rub with damp cloth	Scratches considerably but leaves mirror reflection
Best effect chemical co. cleaner & Passivator	Rub with damp cloth	May scratch no.4 finish slightly
2. Heat tint or heavy discoloration with the following (see notes below)		
Allen stainless polish	Small amount on damp cloth	Excellent heat tint remover
Birdsall's "Staybright"	Rub with damp cloth	Very good for heat tint removable. Doesn't scratch no.4 finish but does scratch no.7
Wyandotte or Bob-O removal	Rub with damp cloth	Good for heat tint
Oxalic acid (use warm) or 5-15% nitric acid	Swab or immerse. Always follow with a 5% sodium carbonate or neutralizer rinse	Good discoloration remover
Best effect chemical co. cleaner & Passivator surface	Rub with damp cloth	May scratch no 4 finish but leaves clean

**CLEANERS AND THEIR EFFECT ON**  
**STAINLESS STEEL**  
**(Cont.)**

Cleaning agent	Method of Application	Effect on Finish
<p>3. The following detergents and solvents are excellent removers of grease, oil and fatty acids, where swabbing or rubbing is not practical.</p>		
<p>4 to 6% solution of            (sodium Metasillcate)            (Trisodium Phosphate)            (Sodium Metaphosphate)            (Sodium Pyrophosphate)</p>		<p>All excellent removers of grease, oil, and milkstone</p>
<p>5-15% caustic soda (hot or cold)</p>		<p>Will remove grease and milkstone</p>
<p>4. The following organic solvents may be used for removing oils and grease deposits:</p>		
<p>Carbon-tetrachloride, Naphtha, Trichlorethylene            Acetone, Kerosene, Gasoline, Ether, Alcohol, Benzene</p>		<p>No affect on finish, however, take all precautions against fire.</p>

Notes: ordinary wool or steel brushes should never be used on stainless steel surfaces. Particles of steel may become imbedded in the stainless steel surface, and rusting of these particles will eventually appear as stains. Use stainless steel wool or sponge on stainless steel equipment. Heat tint removers will usually scratch stainless steel surfaces. This, however, is necessary in removing heat tint by hand. Oakite, a fibrous material, may be used in place of metal sponges or cloth pads for applying cleaners and polishes. This material is effective in aiding in removal of milkstone.

For heavy hard water deposits, 15-20% (by volume) nitric acid is very effective. Acid treatment should be followed by a thorough water rinse.

The action of soldering fluxes should be neutralized immediately with a 5% sodium carbonate solution.

Soap and water followed by a water rinse will not harm stainless steel.

## **PREVENTATIVE MAINTENANCE OF COLORPOINT EQUIPMENT**

*To insure that your equipment will continue to operate properly, please follow these simple steps:*

- 1.. **Always wipe the unit down with a damp cloth. Do not spray water directly in control panel areas or on areas with exposed heating elements.**

LOW TEMP INDUSTRIES  
DISPENSER MECHANISM

THE DISPENSER MECHANISM SHOWN IS USED IN ALL COLORPOINT EQUIPMENT. THIS MECHANISM HAS BEEN ADAPTED FOR MILK AND ICE CREAM DISPENSING AS WELL AS TRAY DISPENSERS. THE DIFFERENCE IN EACH APPLICATION IS THE NUMBER AND TYPE OF SPRINGS USED. THIS EACH MECHANISM CAN HOLD UP TO TWELVE (12) SPRINGS.

THE TOTAL SYSTEM CONSIST OF TWO (2) MECHANISMS WHICH ARE MOUNTED IN SUPPORT CHANNEL MOUNTED TO THE EQUIPMENT AND A PRODUCT SUPPORT PLATFORM WHICH SPANS THE PRODUCT AREA AND RESTS ON THE FLAT BARS WHICH EXTEND OUT EACH SIDE OF THE DISPENSER HOUSING.

TO REMOVE AND CLEAN THE DISPENSING SYSTEM LIFT THE PRODUCT SUPPORT PLATFORM OFF, THE FLAT BAR EXTENSIONS. LIFT EACH DISPENSER UP OUT OF THE SUPPORT CHANNEL. REMOVE THE WING NUT ON THE BOTTOM SIDE OF THE MECHANISM. REMOVE THE BOTTOM CAP AND SLIDE THE INTERNAL SPRING ASSEMBLY OUT. LIFT THE TOP COVER AND GUIDE ROD UP. THE SYSTEM CAN NOW BE PLACED IN A DISHWASHER OR SINK AND CLEANED.

IF TENSION ADJUSTMENTS ARE REQUIRED FOLLOW THE SAME INSTRUCTIONS SHOWN ABOVE TO DISASSEMBLE THE SYSTEM. ADD OR REMOVE SPRINGS AS REQUIRED. LISTED BELOW ARE THE RECOMMENDED SPRING ARRANGEMENTS FOR THIS SYSTEM.

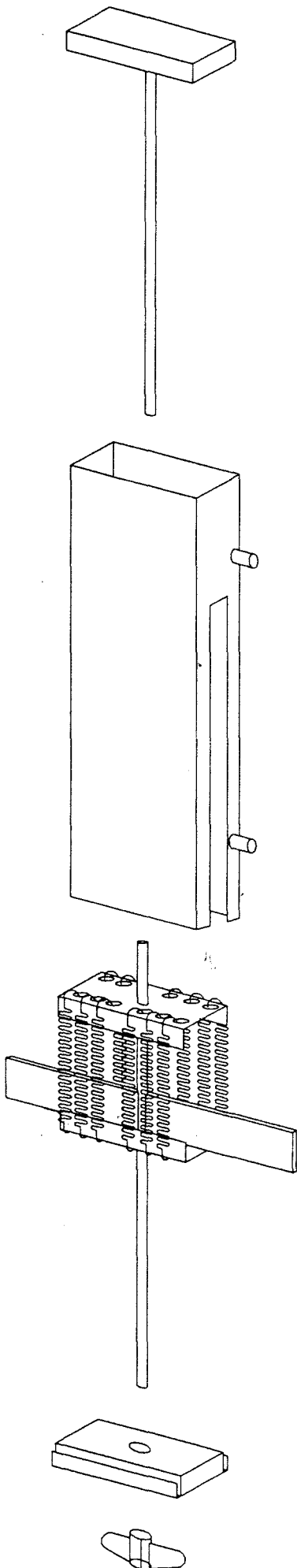

10 X 20 MILK SIX (6) GREEN SPRINGS  
20 X 20 MILK TWELVE (12) GREEN SPRINGS  
10 X 20 ICE CREAM SIX (6) BLUE SPRINGS  
20 X 20 ICE CREAM TWELVE (12) BLUE SPRINGS  
CRATE MILK DISP EIGHT (8) BLUE SPRINGS

TRAY DISPENSING MAY NEED FIELD ADJUSTING  
DUE TO DIFFERENT TYPES AND STYLES OF TRAYS  
STANDARD SPRING ARRANGEMENT IS  
SIX (6) GREEN SPRINGS

# COLORPOINT

8-95

BY LOW TEMP INDUSTRIES  
JONESBORO, GEORGIA

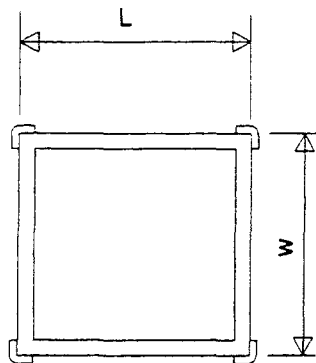

TOP VIEW

RACK DISPENSER FOR  
CUPS, GLASSES OR TRAYS

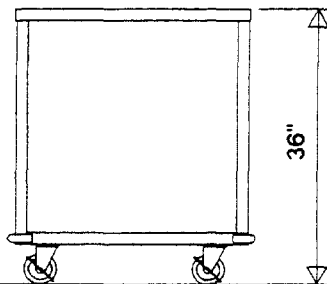

SIDE VIEW

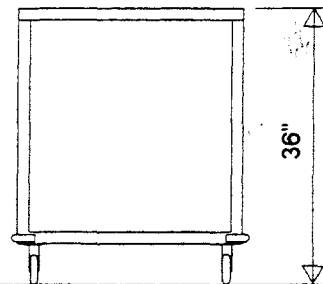

END VIEW

MODEL	RACK OR TRAY SIZE	L X W X H	SHIPPING WT
TD-1014	10 X 14	23" X 18" X 36"	100
TD-1020	10 X 20	29" X 23-1/4" X 36"	105
TD-1418	14 X 18	29" X 23-1/4" X 36"	115
TD-1620	16 X 20	29" X 23-1/4" X 36"	130
TD-1622	16 X 22	31" X 23-1/4" X 36"	130
TD-2020	20 X 20	29" X 27-1/4" X 36"	145

TOP: 14 GAUGE STAINLESS STEEL WITH SQUARE TURN DOWNS ON ALL SIDES AND CORNERS FULLY WELDED AND GROUND AND POLISHED TO A #4 SATIN FINISH WITH ALL EDGES HAVING A #7 HI-LITE FINISH.

BODY AND FRAME: FRAME TO BE 14 GAUGE STAINLESS STEEL CONSTRUCTION. FULL PERIMETER TOP AND BOTTOM FRAME FULLY WELDED, GROUND AND POLISHED TO VERTICAL CORNER UPRIGHTS MAKING BODY FRAME ONE INTEGRAL UNIT. NON MARKING CORNER BUMPERS SECURED TO BOTTOM FRAME

BODY PANELS: SEAMLESS MOLDED FIBERGLASS (F.R.P.) WITH SMOOTH EXTERIOR SURFACE AND ROUNDED CORNERS. ALL FIBERGLASS TO BE FLAME RETARDANT PER SPECIFICATIONS ASTM-E-162 HAVING A FLAME SPREAD OF 25 OR LESS.

DISPENSERS: THE TOP OPENING SHALL CONTAIN A STAINLESS STEEL SELF LEVELING DISPENSER. DISPENSING MECHANISM SHALL BE CONSTRUCTED WITH AUTOMATIC SELF LEVELING ELAVATORS, ENCLOSED IN A STAINLESS STEEL HOUSING. THE ELEVATOR MECHANISM SHALL BE FIELD ADJUSTABLE WITH OUT THE USE OF TOOLS AND BE CONNECTED TO A REMOVABLE HEAVY DUTY GUAGE STAINLESS STEEL CARRIER.

CASTERS: 4" DIAMETER BALL BEARING, SWIVEL TYPE, NON MARKING WITH BRAKES ON ALL WHEELS. CASTERS TO BE MOUNTED WITH INTERNAL AND EXTERNAL BRACING FOR MAXIMUM STRESS RELIEF.

APPROVALS: THIS UNIT IS LISTED BY UNDERWRITERS LABORATORIES FOR SAFETY AND CLASSIFIED BY UNDERWRITERS LABORTORIES BY SANITION UNDER NSF STD 2 AND SHALL BEAR BOTH SEALS.

# COLORPOINT

8-95

BY LOW TEMP INDUSTRIES  
JONESBORO, GEORGIA

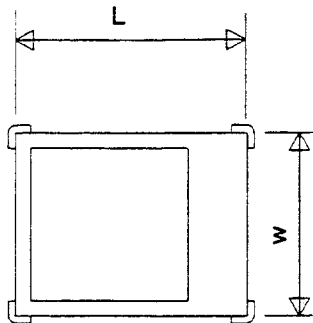

HEATED RACK DISPENSER FOR  
CUPS, GLASSES OR TRAYS

TOP VIEW

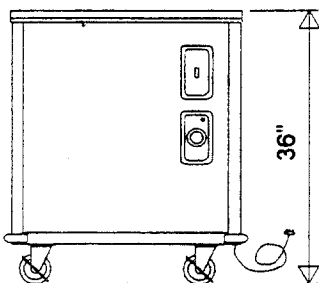

SIDE VIEW

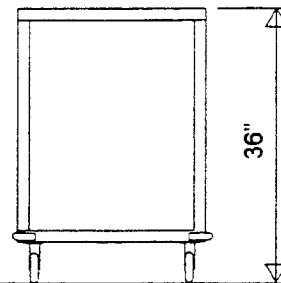

END VIEW

MODEL	PLATFORM SIZE	L X W X H	AMPS 120V/1PH PLUG	NEMA TYPE	SHIPPING WT
TW-1020	20-1/2" X 10-1/2"	28-1/8" X 24-1/8" X 36"	10.8	5-15P	150
TW-2020	20-1/2" X 20-1/2"	34-1/8" X 28-1/8" X 36"	10.8	5-15P	175

TOP: 14 GAUGE STAINLESS STEEL WITH SQUARE TURN DOWNS ON ALL SIDES AND CORNERS FULLY WELDED AND GROUND AND POLISHED TO A #4 SATIN FINISH WITH ALL EDGES HAVING A #7 HI-LITE FINISH.

BODY AND FRAME: FRAME TO BE 14 GAUGE STAINLESS STEEL CONSTRUCTION. FULL PERIMETER TOP AND BOTTOM FRAME FULLY WELDED, GROUND AND POLISHED TO VERTICAL CORNER UPRIGHTS MAKING BODY FRAME ONE INTEGRAL UNIT. NON MARKING CORNER BUMPERS SECURED TO BOTTOM FRAME

BODY PANELS: SEAMLESS MOLDED FIBERGLASS (F.R.P.) WITH SMOOTH EXTERIOR SURFACE AND ROUNDED CORNERS. ALL FIBERGLASS TO BE FLAME RETARDANT PER SPECIFICATIONS ASTM-E-162 HAVING A FLAME SPREAD OF 25 OR LESS.

HEATED DISPENSER: TO BE CONSTRUCTED OF HEAVY GAUGE ALUMINIZED STEEL WELDED FRAME WITH CLOSED CONSTRUCTION. PLATFORM TO BE OF STAINLESS STEEL. HEAT IS PROVIDED BY A 1250 WATT ELEMENT WITH TEMPERATURE CONTROLLED BY A THERMOSTAT RECESSED INTO THE BODY PANEL. DISPENSER TO BE FIELD ADJUSTABLE WITHOUT THE USE OF TOOLS.

CASTERS: 4" DIAMETER BALL BEARING, SWIVEL TYPE, NON MARKING WITH BRAKES ON ALL WHEELS. CASTERS TO BE MOUNTED WITH INTERNAL AND EXTERNAL BRACING FOR MAXIMUM STRESS RELIEF.

APPROVALS: THIS UNIT IS LISTED BY UNDERWRITERS LABORATORIES FOR SAFETY AND CLASSIFIED BY UNDERWRITERS LABORATORIES BY SANITATION UNDER NSF STD 2 AND SHALL BEAR BOTH SEALS.

# COLORPOINT

3-95

BY LOW TEMP INDUSTRIES  
JONESBORO, GEORGIA

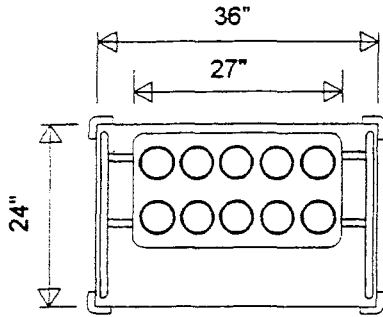

TOP VIEW

TUBULAR TRAY STAND

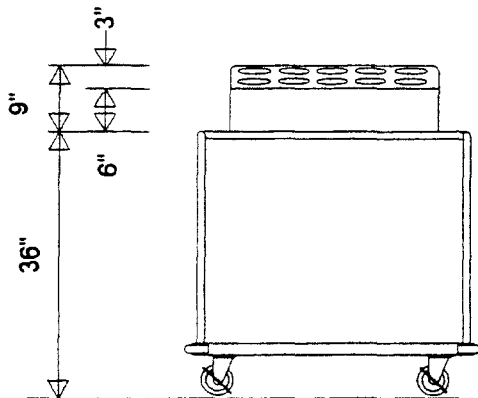

SIDE VIEW

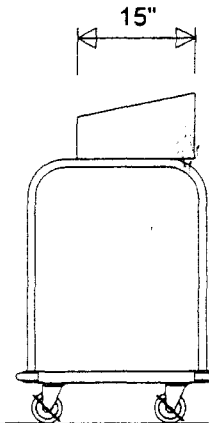

END VIEW

MODEL	L X W X H	MAX. TRAY CAPACITY*	SHIPPING WT
CPM-MTS	36" x 24" x 45"	300	132

\*TRAY MAY VARY DEPENDING ON STACKING HEIGHT OF TRAYS

NOTE: WHEN ORDERING, PLEASE VERIFY EXACT LENGTH, WIDTH, WEIGHT OF ONE TRAY FOR PROPER CALIBRATION.

BASE AND FRAME 14 GAUGE STAINLESS STEEL WITH SQUARE TURN DOWNS ON ALL SIDES AND CORNERS FULLY WELDED AND GROUND AND POLISHED UNDERSIDE REINFORCED WITH HEAVY GAUGE CHANNELS. NON MARKING CORNER BUMPERS SECURED TO BASE. FRAME SHALL BE CONSTRUCTED OF 1" O.D. 16 GAUGE STAINLESS STEEL TUBING BOLTED TO THE BASE.

SILVERWARE DISPENSER: SILVERWARE CONTAINER SHALL BE SEAMLESS MOULDED FIBERGLASS (F.R.P.) WITH SMOOTH EXTERIOR SURFACES ROUNDED CORNERS. SLOPED TOP TO HAVE TEN (10) CUT-OUTS COMPLETE WITH NYLON SILVERWARE CYLINDERS. ALL FIBERGLASS TO BE FLAME RETARDENT PER SPECIFICATION ASTM E-162 HAVING A FLAME SPREAD OF 25 OR LESS. SILVERWARE CONTAINERS TO BE SECURED TO TRAY DISPENSER FRAME BY 1" 16 GAUGE STAINLESS STEEL TUBING.

CASTERS: 4" DIAMETER, BALL BEARING, SWIVEL TYPE CASTER TO BE NON MARKING AND WITH BRAKES ON ALL WHEELS.

APPROVALS: THIS UNIT IS CLASSIFIED BY UNDERWRITERS LABORATORIES FOR SANITATION UNDER NSF STD 2 AND SHALL BEAR THE SEAL.

# COLORPOINT

3-95

BY LOW TEMP INDUSTRIES  
JONESBORO, GEORGIA

## TUBULAR TRAY DISPENSER

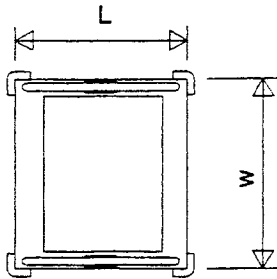

TOP VIEW

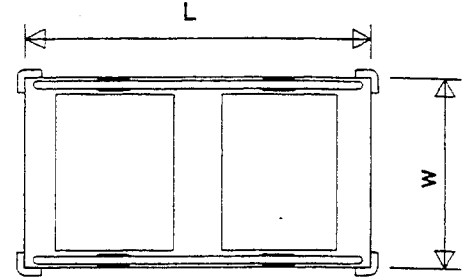

TOP VIEW

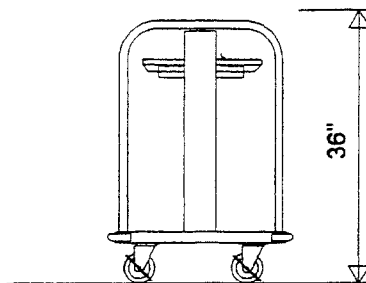

SIDE VIEW

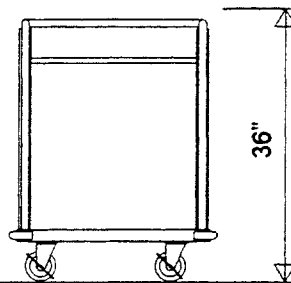

END VIEW

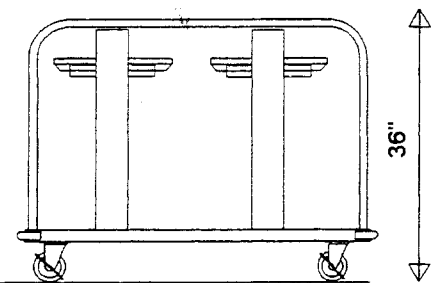

SIDE VIEW

MODEL	L X W X H	NOMINAL TRAY SIZE	NO. TRAY STACKS	MAX. TRAY CAPACITY*	SHIPPING WT
CPM-MTD-1216	19-1/8" X 21-3/4" X 35-3/4"	21-1/4" X 16-1/2"	1	150	70
CPM-MTD-1418	21-1/8" X 23-3/4" X 35-3/4"	14" X 18"	1	150	75
CPM-MTD-1520	22-1/8" X 25-3/4" X 35-3/4"	15-1/4" X 20-1/2"	1	150	77
CPM-MTD-1622	23-1/8" X 27-3/4" X 35-3/4"	16" X 22"	1	150	82
CPM-MTD-1821	25-1/8" X 26-3/4" X 35-3/4"	17-1/2" X 21"	1	150	84
CPM-MTD-2-1014	27-1/4" X 22-1/4" X 35-3/4"	10" X 14"	2	300	85
CPM-MTD-2-1216	38-1/4" X 21-3/4" X 35-3/4"	21-1/4" X 16-1/2"	2	300	100
CPM-MTD-2-1418	42-1/4" X 23-3/4" X 35-3/4"	14" X 18"	2	300	136
CPM-MTD-2-1520	44-1/4" X 25-3/4" X 35-3/4"	15-1/4" X 20-1/2"	2	300	138
CPM-MTD-2-1622	46-1/8" X 27-3/4" X 35-3/4"	16" X 22"	2	300	148
CPM-MTD-2-1821	50-1/4" X 26-3/4" X 35-3/4"	17-1/2" X 21"	2	300	152

\*TRAY MAY VARY DEPENDING ON STACKING HEIGHT OF TRAYS

NOTE: WHEN ORDERING, PLEASE VERIFY EXACT LENGTH, WIDTH, WEIGHT OF ONE TRAY FOR PROPER CALIBRATION

BASE AND FRAME 14 GAUGE STAINLESS STEEL WITH SQUARE TURN DOWNS ON ALL SIDES AND CORNERS FULLY WELDED AND GROUND AND POLISHED UNDERSIDE REINFORCED WITH HEAVY GAUGE CHANNELS. NON MARKING CORNER BUMPERS SECURED TO BASE. FRAME SHALL BE CONSTRUCTED OF 1" O.D. 16 GAUGE STAINLESS STEEL TUBING BOLTED TO THE BASE.

TRAY DISPENSERS: EASILY REMOVABLE SELF LEVELING MECHANISMS SHALL BE FIELD ADJUSTABLE WITHOUT THE USE OF TOOLS AND SHALL BE SUPPLIED WITH A STAINLESS STEEL TRAY PLATFORM.

CASTERS: 4" DIAMETER, BALL BEARING, SWIVEL TYPE CASTER TO BE NON MARKING AND WITH BRAKES ON ALL WHEELS.

APPROVALS: THIS UNIT IS CLASSIFIED BY UNDERWRITERS LABORATORIES FOR SANITATION UNDER NSF STD 2 AND SHALL BEAR THE SEAL.

# COLORPOINT

3-95

BY LOW TEMP INDUSTRIES  
JONESBORO, GEORGIA

## TUBULAR RACK DISPENSER

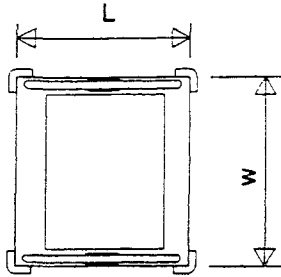

TOP VIEW

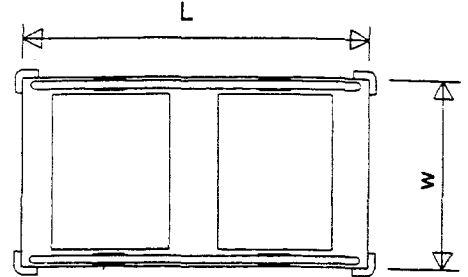

TOP VIEW

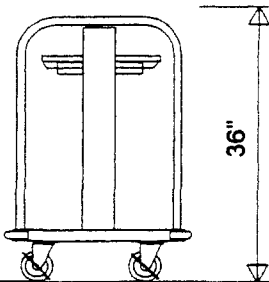

SIDE VIEW

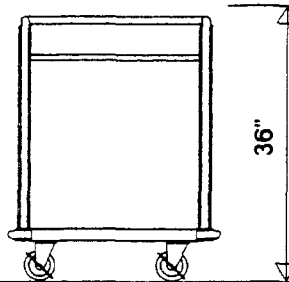

END VIEW

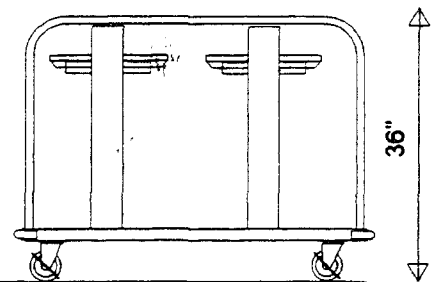

SIDE VIEW

MODEL	RACK OR TRAY SIZE	L X W X H	SHIPPING WT
CPM-MRD-1020	10 X 20	17-1/8" X 25-3/4" X 35-3/4"	65
CPM-MRD-1418	14 X 18	21-1/8" X 23-3/4" X 35-3/4"	75
CPM-MRD-1420	14 X 20	21-1/8" X 25-3/4" X 35-3/4"	75
CPM-MRD-1620	16 X 20	23-1/8" X 25-3/4" X 35-3/4"	80
CPM-MRD-1818	18 X 18	25-1/8" X 23-3/4" X 35-3/4"	80
CPM-MRD-1820	18 X 20	25-1/8" X 25-3/4" X 35-3/4"	83
CPM-MRD-2020	20 X 20	27-1/8" X 25-3/4" X 35-3/4"	83
CPM-MRD-2-1020	10 X 20	34-1/4" X 25-3/4" X 35-3/4"	90

NOTE! WHEN ORDERING, PLEASE VERIFY THE FOLLOWING INFORMATION FOR PROPER CALIBRATION.

RACK STACKING HEIGHT \_\_\_\_\_  
 RACK LENGTH \_\_\_\_\_  
 RACK WIDTH \_\_\_\_\_  
 WT. OF LOADED RACK \_\_\_\_\_ LBS. \_\_\_\_\_ OZ  
 FOR CUPS \_\_\_\_\_ or GLASSES \_\_\_\_\_  
 DIA. OF ONE PIECE \_\_\_\_\_  
 HEIGHT OF ONE PIECE \_\_\_\_\_  
 WEIGHT OF ONE PIECE \_\_\_\_\_  
 MAX. DIA OF ONE PIECE \_\_\_\_\_  
 HEIGHT OF ONE GLASS \_\_\_\_\_  
 WEIGHT OF ONE GLASS \_\_\_\_\_

BASE AND FRAME 14 GAUGE STAINLESS STEEL WITH SQUARE TURN DOWNS ON ALL SIDES AND CORNERS FULLY WELDED AND GROUND AND POLISHED UNDERSIDE REINFORCED WITH HEAVY GAUGE CHANNELS. NON MARKING CORNER BUMPERS SECURED TO BASE. FRAME SHALL BE CONSTRUCTED OF 1" O.D. 16 GAUGE STAINLESS STEEL TUBING BOLTED TO THE BASE.

TRAY DISPENSERS: EASILY REMOVABLE SELF LEVELING MECHANISMS SHALL BE FIELD ADJUSTABLE WITHOUT THE USE OF TOOLS AND SHALL BE SUPPLIED WITH A STAINLESS STEEL TRAY PLATFORM.

CASTERS: 4" DIAMETER, BALL BEARING, SWIVEL TYPE CASTER TO BE NON MARKING AND WITH BRAKES ON ALL WHEELS.

APPROVALS: THIS UNIT IS CLASSIFIED BY UNDERWRITERS LABORATORIES FOR SANITATION UNDER NSF STD 2 AND SHALL BEAR THE SEAL

# COLORPOINT

3-95

BY LOW TEMP INDUSTRIES  
JONESBORO, GEORGIA

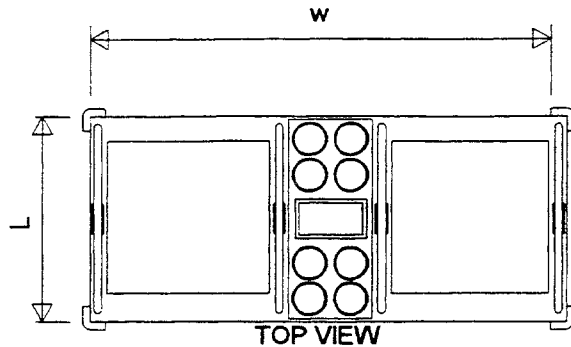

TRAY, SILVERWARE  
AND NAPKIN DISPENSER

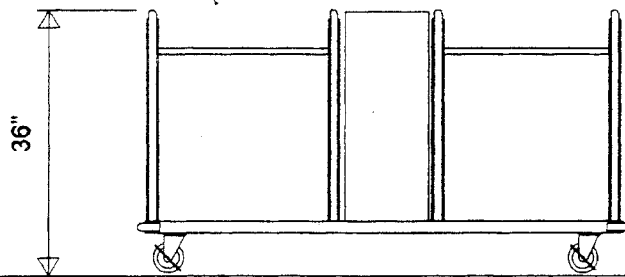

SIDE VIEW

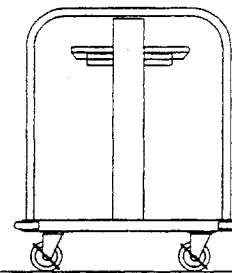

END VIEW

MODEL	L X W X H	NOMINAL TRAY SIZE	NO. TRAY STACKS	MAX. TRAY CAPACITY*	SHIPPING WT
CPM-HNS-2-0915	43-3/4" x 27-1/4" x 55-3/4"	9 X 15	2	300	85
CPM-HNS-2-1014	43-3/4" x 27-1/4" x 55-3/4"	10 X 14	2	300	85
CPM-HNS-2-1216	47-3/4" X 27-1/4" X 55-3/4"	12-1/4 X 16-1/2	2	300	100
CPM-HNS-2-1418	51-3/4" x 27-1/4" x 55-3/4"	14 X 18	2	300	136
CPM-HNS-2-1520	54-1/2" x 27-1/4" x 55-3/4"	15-1/4 X 20-1/2	2	300	138
CPM-HNS-2-1622	56-1/2" x 27-1/4" x 55-3/4"	16 X 22	2	300	148
CPM-HNS-2-1821	60-1/2" x 27-1/4" x 55-3/4"	17-1/2 X 21	2	300	152

\*TRAY MAY VARY DEPENDING ON STACKING HEIGHT OF TRAYS  
NOTE: WHEN ORDERING, PLEASE VERIFY EXACT LENGTH, WIDTH, WEIGHT OF ONE TRAY FOR PROPER CALIBRATION.

BASE AND FRAME 14 GAUGE STAINLESS STEEL WITH SQUARE TURN DOWNS ON ALL SIDES AND CORNERS FULLY WELDED AND GROUND AND POLISHED UNDERSIDE REINFORCED WITH HEAVY GAUGE CHANNELS. NON MARKING CORNER BUMPERS SECURED TO BASE. FRAME SHALL BE CONSTRUCTED OF 1" O.D. 16 GAUGE STAINLESS STEEL TUBING BOLTED TO THE BASE.

TRAY DISPENSERS: EASILY REMOVABLE SELF LEVELING MECHANISMS SHALL BE FIELD ADJUSTABLE WITHOUT THE USE OF TOOLS AND SHALL BE SUPPLIED WITH A STAINLESS STEEL TRAY PLATFORM.

SILVERWARE AND NAPKIN DISPENSER: CENTER PYLON SHALL BE SEAMLESS MOULDED FIBERGLASS (F.R.P.) WITH SMOOTH EXTERIOR SURFACE AND ROUNDED CORNERS. TOP TO HAVE EIGHT (8) CUT-OUTS COMPLETE WITH NYLON SILVERWARE CYLINDERS AND ONE (1) 1/4 SIZE X 6" DEEP PAN FOR NAPKINS. ALL FIBERGLASS TO BE FLAME RETARDENT PER SPECIFICATION ASTM E-162 HAVING A FLAME SPREAD OF 25 OR LESS.

CASTERS: 4" DIAMETER, BALL BEARING, SWIVEL TYPE CASTER TO BE NON MARKING AND WITH BRAKES ON ALL WHEELS.

APPROVALS: THIS UNIT IS CLASSIFIED BY UNDERWRITERS LABORATORIES FOR SANITATION UNDER NSF STD 2 AND SHALL BEAR THE SEAL.

# COLORPOINT

3-95

BY LOW TEMP INDUSTRIES  
JONESBORO, GEORGIA

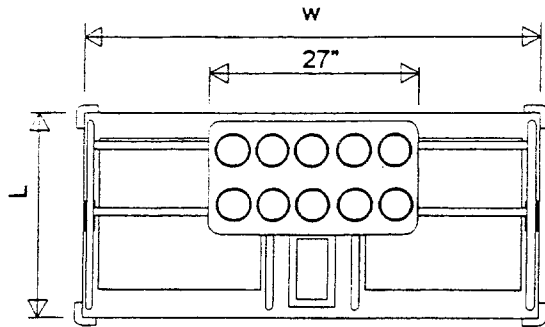

TUBULAR TRAY, SILVERWARE  
AND NAPKIN DISPENSER

TOP VIEW

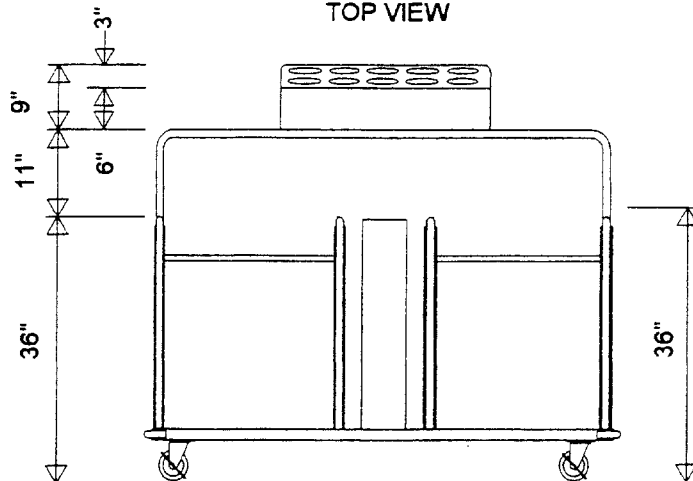

SIDE VIEW

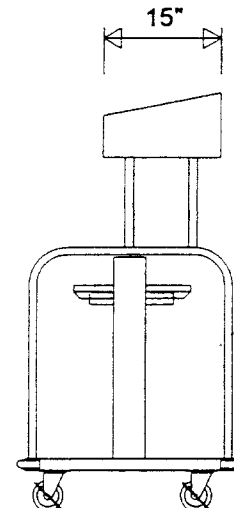

END VIEW

MODEL	L X W X H	NOMINAL TRAY SIZE	NO. TRAY STACKS	MAX. TRAY CAPACITY*	SHIPPING WT
CPM-NST-2-1014	43-3/4" x 27-1/4" x 55-3/4"	10 X 14	2	300	125
CPM-NST-2-1216	47-3/4" x 27-1/4" x 55-3/4"	12-1/4 X 16-1/2	2	300	140
CPM-NST-2-1418	51-3/4" x 27-1/4" x 55-3/4"	14 X 18	2	300	176
CPM-NST-2-1520	54-1/2" x 27-1/4" x 55-3/4"	15-1/4 X 20-1/2	2	300	178
CPM-NST-2-1622	56-1/2" x 27-1/4" x 55-3/4"	16 X 22	2	300	188
CPM-NST-2-1821	60-1/2" x 27-1/4" x 55-3/4"	17-1/2 X 21	2	300	192

\*TRAY MAY VARY DEPENDING ON STACKING HEIGHT OF TRAYS

NOTE: WHEN ORDERING, PLEASE VERIFY EXACT LENGTH, WIDTH, WEIGHT OF ONE TRAY FOR PROPER CALIBRATION.

BASE AND FRAME 14 GAUGE STAINLESS STEEL WITH SQUARE TURN DOWNS ON ALL SIDES AND CORNERS FULLY WELDED AND GROUND AND POLISHED UNDERSIDE REINFORCED WITH HEAVY GAUGE CHANNELS. NON MARKING CORNER BUMPERS SECURED TO BASE. FRAME SHALL BE CONSTRUCTED OF 1" O.D. 16 GAUGE STAINLESS STEEL TUBING BOLTED TO THE BASE.

TRAY DISPENSERS: EASILY REMOVABLE SELF LEVELING MECHANISMS SHALL BE FIELD ADJUSTABLE WITHOUT THE USE OF TOOLS AND SHALL BE SUPPLIED WITH A STAINLESS STEEL TRAY PLATFORM.

SILVERWARE DISPENSER: SILVERWARE DISPENSER SCONTAINER SHALL BE SEAMLESS MOULDED FIBERGLASS (F.R.P.) WITH SMOOTH EXTERIOR SURFACE AND ROUNDED CORNERS. SLOPED TOP TO HAVE TEN (10) CUT-OUTS COMPLETE WITH NYLON SILVERWARE CYLINDRS. ALL FIBERGLASS TO BE FLAME RETARDENT PER SPECIFICATION ASTM E-162 HAVING A FLAME SPREAD OF 25 OR LESS. SILVERWARE CONTAINER TO BE SECURED TO TRAY DISPENSER FRAME BY 1" 16 GAUGE STAINLESS STEEL TUBING.

NAPKIN DISPENSER: DOUBLE NAPKIN DISPENSER TO BE FABRICATED FROM SEAMLESS MOULDED FIBERGLASS WITH THE SAME SPECIFICATIONS AS THE SILVER WARE DISPENSER. TWO (2) SELF-LEVELING NAPKIN DISPENSERS SHALL BE MOUNTED IN THE TOP OF THE CENTER PYLON AND WILL DISPENSE NAPKINS ONE-AT-A-TIME. NAPKIN SIZE MUST BE VERIFIED.

CASTERS: 4" DIAMETER, BALL BEARING, SWIVEL TYPE CASTER TO BE NON MARKING AND WITH BRAKES ON ALL WHEELS.

APPROVALS: THIS UNIT IS CLASSIFIED BY UNDERWRITERS LABORATORIES FOR SANITATION UNDER NSF STD 2 AND SHALL BEAR THE SEAL.

# COLORPOINT

3-95

BY LOW TEMP INDUSTRIES  
JONESBORO, GEORGIA

## DISH CARTS

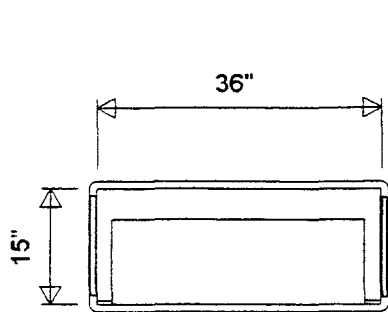

TOP VIEW

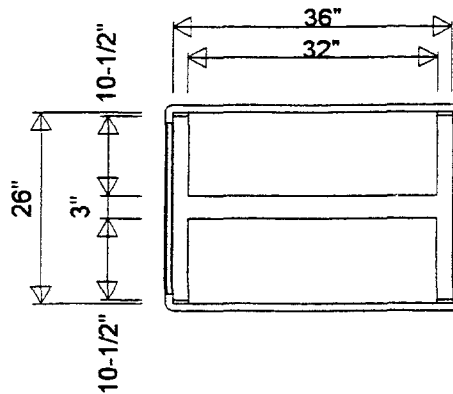

TOP VIEW

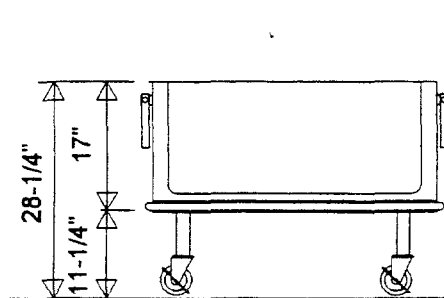

SIDE VIEW

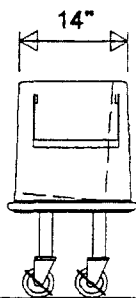

END VIEW

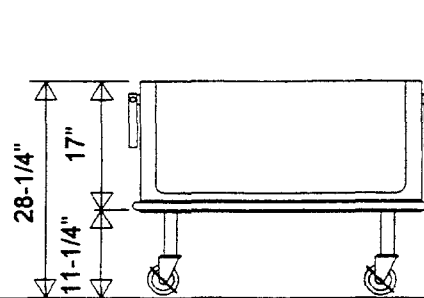

SIDE VIEW

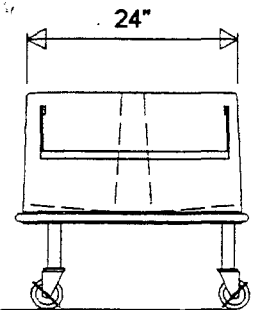

MODEL	L X W X H	SHIPPING WT
CDS-14	37-1/2" X 14-7/8" X 29"	40
CDS-24	27-1/2" X 27-3/4" X 29"	75

BODY AND FRAME: BODY OF DISH COMPARTMENT CONSTRUCTED OF SEAMLESS MOULDED FIBERGLASS (F.R.P.) WITH ROUNDED EXTERIOR CORNERS AND COVED INTERIOR VERTICAL AND HORIZONTAL CORNERS. ALL FIBERGLASS TO BE FLAME RETARDANT PER SPECIFICATION ASTM E-162 HAVING A FLAME SPREAD OF 25 OR LESS. THE SHELF PORTION OF THE BODY TO HAVE A MOLDED IN NON-SKID SURFACE. THE EXTERIOR ENDS (AND BACK ON A CDS-14) SHALL HAVE A FIBERGLASS INSERT PANEL HELD IN PLACE BY A 14 GAUGE STAINLESS STEEL WELDED ANGLE FRAME. A STAINLESS STEEL FOLD DOWN HANDLE IS TO BE MOUNTED ON EACH END OF THE BODY. WRAP AROUND BUMPERS IS TO BE SECURED TO FULL PERIMETER OF BODY.

THE CONCEALED INTERIOR BODY FRAME TO BE FULLY WELDED COMPLETE WITH 1-5/8" O.D. 16 GAUGE STAINLESS STEEL TUBULAR LEGS WELDED TO THE FRAME.

CASTERS: 4" DIAMETER, BALL BEARING, SWIVEL TYPE CASTER TO BE NON MARKING AND WITH BRAKES ON ALL WHEELS.

APPROVALS: THIS UNIT IS CLASSIFIED BY UNDERWRITERS LABORATORIES FOR SANITATION UNDER NSF STD 2 AND SHALL BEAR THE SEAL

# COLORPOINT

3-95

BY LOW TEMP INDUSTRIES  
JONESBORO, GEORGIA

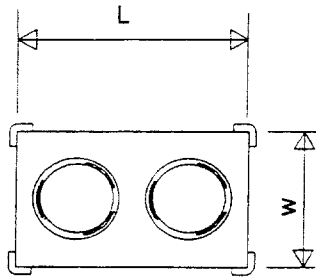

TOP VIEW

PLATE DISPENSER  
NON-HEATED

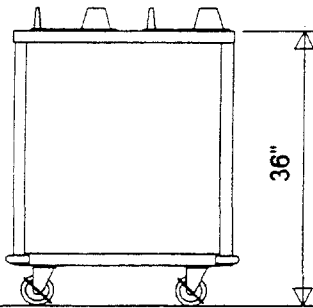

SIDE VIEW

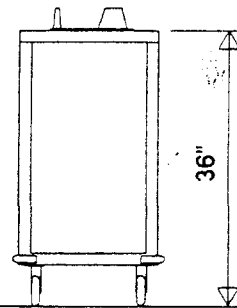

END VIEW

MODEL	DINNERWARE DIA.	L X W X H	SHIPPING WT
2PD-52	UP to 5"	29" x 18" x 36"	85
2PD-60	5-1/8 to 5-3/4	29" x 18" x 36"	100
2PD-66	5-7/8 to 6-1/2	29" x 18" x 36"	100
2PD-74	6-5/8 to 7-1/4	29" x 18" x 36"	100
2PD-83	7-3/8 to 8-1/8"	29" x 18" x 36"	130
2PD-93	8-1/4 to 9-1/8"	29" x 18" x 36"	130
2PD-103	9-1/4 to 10-1/8"	35" x 20" x 36"	140
2PD-121	10-1/4 to 11-7/8"	35" x 20" x 36"	140

TOP: 14 GAUGE STAINLESS STEEL WITH SQUARE TURN DOWNS ON ALL SIDES AND CORNERS FULLY WELDED AND GROUND AND POLISHED TO A #4 SATIN FINISH WITH ALL EDGES HAVING A #7 HI-LITE FINISH.

BODY AND FRAME: FRAME TO BE 14 GAUGE STAINLESS STEEL CONSTRUCTION. FULL PERIMETER TOP AND BOTTOM FRAME FULLY WELDED, GROUND AND POLISHED TO VERTICAL CORNER UPRIGHTS MAKING BODY FRAME ONE INTEGRAL UNIT. NON MARKING CORNER BUMPERS SECURED TO BOTTOM FRAME

BODY PANELS: SEAMLESS MOLDED FIBERGLASS (F.R.P.) WITH SMOOTH EXTERIOR SURFACE AND ROUNDED CORNERS. ALL FIBERGLASS TO BE FLAME RETARDANT PER SPECIFICATIONS ASTM-E-162 HAVING A FLAME SPREAD OF 25 OR LESS.

PLATE DISPENSERS: UN HEATED DISPENSERS TO BE FIELD ADJUSTABLE WITHOUT THE USE OF TOOL. FOR USE WITH PLASTIC OR CHINA DINNERWARE. CORRECT DISPENSING HEIGHT IS PRODUCED AUTOMATICALLY WHEN CORRECT SPRING RATE IS REACHED. BY CONNECTING SELF CONTAINED EXTENSION SPRINGS, THE SPRING RATE CAN BE INCREASED IN INCREMENTS OF 2.5 OZ/INCH OR 4 OZ/ INCH. A STORAGE BANK SHALL BE PROVIDED FOR EXTENSION SPRINGS WHEN NOT IN USE. TUBE TO BE ENCASED IN INDIVIDUAL STAINLESS STEEL JACKETS WITH A REINFORCED BOTTOM. TUBES TO BE REMOVABLE FOR EASY CLEANING.

CASTERS: 4" DIAMETER BALL BEARING, SWIVEL TYPE, NON MARKING WITH BRAKES ON ALL WHEELS. CASTERS TO BE MOUNTED WITH INTERNAL AND EXTERNAL BRACING FOR MAXIMUM STRESS RELIEF.

APPROVALS: THIS UNIT IS LISTED BY UNDERWRITERS LABORATORIES FOR SAFETY AND CLASSIFIED BY UNDERWRITERS LABORATORIES BY SANITATION UNDER NSF STD 2 AND SHALL BEAR BOTH SEALS.

# COLORPOINT

3-95

BY LOW TEMP INDUSTRIES  
JONESBORO, GEORGIA

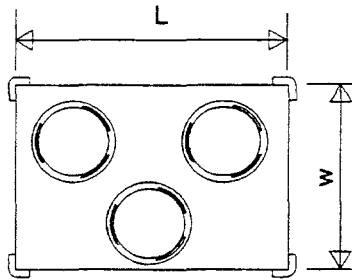

TOP VIEW

PLATE DISPENSER  
NON-HEATED

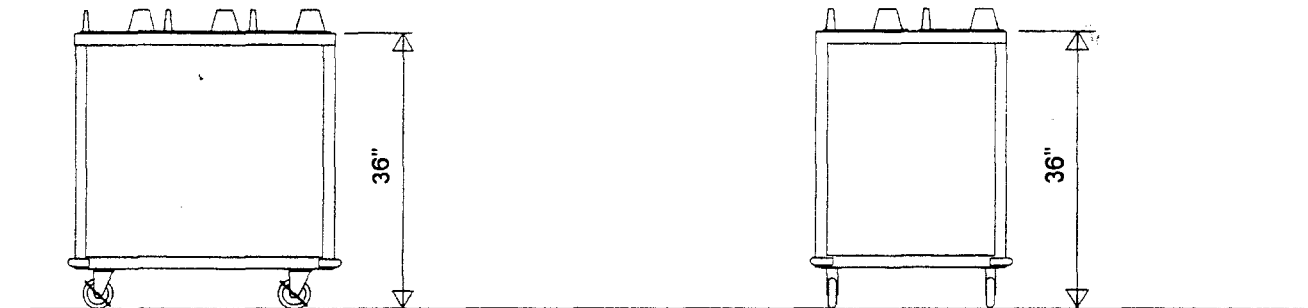

SIDE VIEW

END VIEW

MODEL	DINNERWARE DIA.	L X W X H	SHIPPING WT
3PD-52	UP to 5"	35" x 22-1/4" x 36"	140
2PD-60	5-1/8 to 5-3/4	35" x 22-1/4" x 36"	140
3PD-66	5-7/8 to 6-1/2	35" x 22-1/4" x 36"	140
3PD-74	6-5/8 to 7-1/4	35" x 22-1/4" x 36"	140
3PD-83	7-3/8" to 8-1/8"	47" x 23-1/2" x 36"	185
3PD-93	8-1/4" to 9-1/8"	47" x 23-1/2" x 36"	185
3PD-103	9-1/4" to 10-1/8"	47" x 23-1/2" x 36"	185
3PD-121	10-1/4" to 11-7/8"	49" x 26-1/8" x 36"	200

TOP: 14 GAUGE STAINLESS STEEL WITH SQUARE TURN DOWNS ON ALL SIDES AND CORNERS FULLY WELDED AND GROUND AND POLISHED TO A #4 SATIN FINISH WITH ALL EDGES HAVING A #7 HI-LITE FINISH.

BODY AND FRAME: FRAME TO BE 14 GAUGE STAINLESS STEEL CONSTRUCTION. FULL PERIMETER TOP AND BOTTOM FRAME FULLY WELDED, GROUND AND POLISHED TO VERTICAL CORNER UPRIGHTS MAKING BODY FRAME ONE INTEGRAL UNIT. NON MARKING CORNER BUMPERS SECURED TO BOTTOM FRAME

BODY PANELS: SEAMLESS MOLDED FIBERGLASS (F.R.P.) WITH SMOOTH EXTERIOR SURFACE AND ROUNDED CORNERS. ALL FIBERGLASS TO BE FLAME RETARDANT PER SPECIFICATIONS ASTM-E-162 HAVING A FLAME SPREAD OF 25 OR LESS.

PLATE DISPENSERS: UN HEATED DISPENSERS TO BE FIELD ADJUSTABLE WITHOUT THE USE OF TOOL. FOR USE WITH PLASTIC OR CHINA DINNERWARE. CORRECT DISPENSING HEIGHT IS PRODUCED AUTOMATICALLY WHEN CORRECT SPRING RATE IS REACHED. BY CONNECTING SELF CONTAINED EXTENSION SPRINGS, THE SPRING RATE CAN BE INCREASED IN INCREMENTS OF 2.5 OZ/INCH OR 4 OZ./ INCH. A STORAGE BANK SHALL BE PROVIDED FOR EXTENSION SPRINGS WHEN NOT IN USE. TUBE TO BE ENCASED IN INDIVIDUAL STAINLESS STEEL JACKETS WITH A REINFORCED BOTTOM. TUBES TO BE REMOVABLE FOR EASY CLEANING.

CASTERS: 4" DIAMETER BALL BEARING, SWIVEL TYPE, NON MARKING WITH BRAKES ON ALL WHEELS. CASTERS TO BE MOUNTED WITH INTERNAL AND EXTERNAL BRACING FOR MAXIMUM STRESS RELIEF.

APPROVALS: THIS UNIT IS LISTED BY UNDERWRITERS LABORATORIES FOR SAFETY AND CLASSIFIED BY UNDERWRITERS LABORATORIES BY SANITATION UNDER NSF STD 2 AND SHALL BEAR BOTH SEALS.

# COLORPOINT

3-95

BY LOW TEMP INDUSTRIES  
JONESBORO, GEORGIA

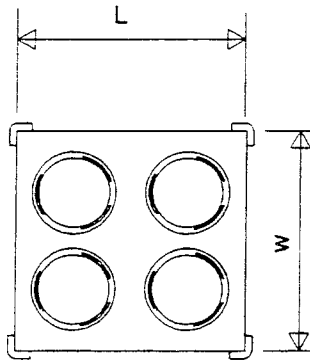
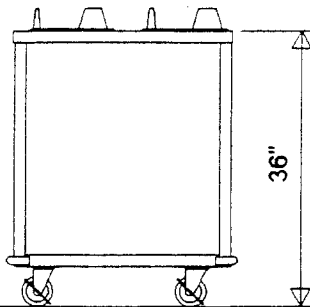
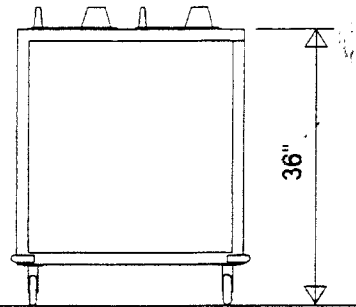

PLATE DISPENSER  
NON-HEATED

TOP VIEW



SIDE VIEW



END VIEW

MODEL	DINNERWARE DIA.	L X W X H	SHIPPING WT
4PD-52	UP to 5"	29" x 29" x 36"	135
4PD-60	5-1/8 to 5-3/4	29" x 29" x 36"	175
4PD-66	5-7/8 to 6-1/2	29" x 29" x 36"	175
4PD-74	6-5/8 to 7-1/4	29" x 29" x 36"	175
4PD-83	7-3/8" to 8-1/8"	29" x 29" x 36"	215
4PD-93	8-1/4" to 9-1/8"	29" x 29" x 36"	215
4PD-103	9-1/4" to 10-1/8"	35" x 35" x 36"	275
4PD-121	10-1/4" to 11-7/8"	35" x 35" x 36"	275

TOP: 14 GAUGE STAINLESS STEEL WITH SQUARE TURN DOWNS ON ALL SIDES AND CORNERS FULLY WELDED AND GROUND AND POLISHED TO A #4 SATIN FINISH WITH ALL EDGES HAVING A #7 HI-LITE FINISH.

BODY AND FRAME: FRAME TO BE 14 GAUGE STAINLESS STEEL CONSTRUCTION. FULL PERIMETER TOP AND BOTTOM FRAME FULLY WELDED, GROUND AND POLISHED TO VERTICAL CORNER UPRIGHTS MAKING BODY FRAME ONE INTEGRAL UNIT. NON MARKING CORNER BUMPERS SECURED TO BOTTOM FRAME

BODY PANELS: SEAMLESS MOLDED FIBERGLASS (F.R.P.) WITH SMOOTH EXTERIOR SURFACE AND ROUNDED CORNERS. ALL FIBERGLASS TO BE FLAME RETARDANT PER SPECIFICATIONS ASTM-E-162 HAVING A FLAME SPREAD OF 25 OR LESS.

PLATE DISPENSERS: UN HEATED DISPENSERS TO BE FIELD ADJUSTABLE WITHOUT THE USE OF TOOL. FOR USE WITH PLASTIC OR CHINA DINNERWARE. CORRECT DISPENSING HEIGHT IS PRODUCED AUTOMATICALLY WHEN CORRECT SPRING RATE IS REACHED. BY CONNECTING SELF CONTAINED EXTENSION SPRINGS, THE SPRING RATE CAN BE INCREASED IN INCREMENTS OF 2.5 OZ/INCH OR 4 OZ./ INCH. A STORAGE BANK SHALL BE PROVIDED FOR EXTENSION SPRINGS WHEN NOT IN USE. TUBE TO BE ENCASED IN INDIVIDUAL STAINLESS STEEL JACKETS WITH A REINFORCED BOTTOM. TUBES TO BE REMOVABLE FOR EASY CLEANING.

CASTERS: 4" DIAMETER BALL BEARING, SWIVEL TYPE, NON MARKING WITH BRAKES ON ALL WHEELS. CASTERS TO BE MOUNTED WITH INTERNAL AND EXTERNAL BRACING FOR MAXIMUM STRESS RELIEF.

APPROVALS: THIS UNIT IS LISTED BY UNDERWRITERS LABORATORIES FOR SAFETY AND CLASSIFIED BY UNDERWRITERS LABORATORIES BY SANITATION UNDER NSF STD 2 AND SHALL BEAR BOTH SEALS.

# COLORPOINT

3-95

BY LOW TEMP INDUSTRIES  
JONESBORO, GEORGIA

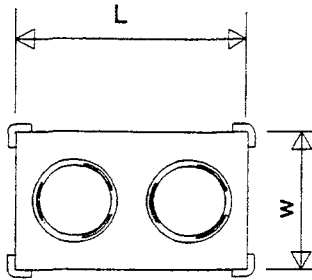

TOP VIEW

PLATE DISPENSER  
HEATED

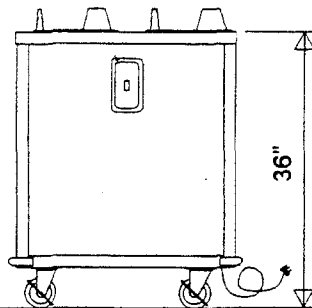

SIDE VIEW

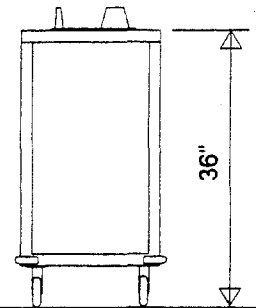

END VIEW

MODEL	DINNERWARE DIA.	L X W X H	AMPS 120V-1PH	NEMA PLUG TYPE	SHIPPING WT
2PW-52	UP to 5"	29" x 18" x 36"	3.5	5-15P	110
2PW-60	5-1/8 to 5-3/4	29" x 18" x 36"	4.0	5-15P	135
2PW-66	5-7/8 to 6-1/2	29" x 18" x 36"	4.5	5-15P	135
2PW-74	6-5/8 to 7-1/4	29" x 18" x 36"	5.0	5-15P	135
2PW-83	7-3/8 to 8-1/8"	29" x 18" x 36"	5.5	5-15P	155
2PW-93	8-1/4 to 9-1/8"	29" x 18" x 36"	6.3	5-15P	155
2PW-103	9-1/4 to 10-1/8"	35" x 20" x 36"	7.0	5-15P	200
2PW-121	10-1/4 to 11-7/8"	35" x 20" x 36"	8.3	5-15P	200

TOP: 14 GAUGE STAINLESS STEEL WITH SQUARE TURN DOWNS ON ALL SIDES AND CORNERS FULLY WELDED AND GROUND AND POLISHED TO A #4 SATIN FINISH WITH ALL EDGES HAVING A #7 HI-LITE FINISH.

BODY AND FRAME: FRAME TO BE 14 GAUGE STAINLESS STEEL CONSTRUCTION. FULL PERIMETER TOP AND BOTTOM FRAME FULLY WELDED, GROUND AND POLISHED TO VERTICAL CORNER UPRIGHTS MAKING BODY FRAME ONE INTEGRAL UNIT. NON MARKING CORNER BUMPERS SECURED TO BOTTOM FRAME

BODY PANELS: SEAMLESS MOLDED FIBERGLASS (F. R. P.) WITH SMOOTH EXTERIOR SURFACE AND ROUNDED CORNERS. ALL FIBERGLASS TO BE FLAME RETARDANT PER SPECIFICATIONS ASTM-E-162 HAVING A FLAME SPREAD OF 25 OR LESS.

PLATE DISPENSERS: HEATED DISPENSERS TO BE FIELD ADJUSTABLE WITHOUT THE USE OF TOOL. FOR USE WITH PLASTIC OR CHINA DINNERWARE. CORRECT DISPENSING HEIGHT IS PRODUCED AUTOMATICALLY WHEN CORRECT SPRING RATE IS REACHED. BY CONNECTING SELF CONTAINED EXTENSION SPRINGS, THE SPRING RATE CAN BE INCREASED IN INCREMENTS OF 2.5 OZ/INCH OR 4 OZ/INCH. A STORAGE BANK SHALL BE PROVIDED FOR EXTENSION SPRINGS WHEN NOT IN USE. TUBE TO BE ENCASED IN INDIVIDUAL STAINLESS STEEL JACKETS WITH A REINFORCED BOTTOM. EACH HEATED TUBE SHALL HAVE A SELF CONTAINED HEATING SYSTEM WITH AN INDIVIDUAL ON-OFF SWITCH, INDICATOR LIGHT AND THERMOSTAT. AN ELECTRICAL RECEPTACLE IS MOUNTED ON THE INTERIOR BOTTOM OF BODY WITH A 6 FOOT GROUNDED SUPPLY CORD. A CORD HANGING BRACKET IS TO BE PROVIDED ON BODY EXTERIOR. TUBES TO BE REMOVABLE FOR EASY CLEANING.

CASTERS: 4" DIAMETER BALL BEARING, SWIVEL TYPE, NON MARKING WITH BRAKES ON ALL WHEELS. CASTERS TO BE MOUNTED WITH INTERNAL AND EXTERNAL BRACING FOR MAXIMUM STRESS RELIEF.

APPROVALS: THIS UNIT IS LISTED BY UNDERWRITERS LABORATORIES FOR SAFETY AND CLASSIFIED BY UNDERWRITERS LABORATORIES BY SANITATION UNDER NSF STD 2 AND SHALL BEAR BOTH SEALS.

# COLORPOINT

3-95

BY LOW TEMP INDUSTRIES  
JONESBORO, GEORGIA

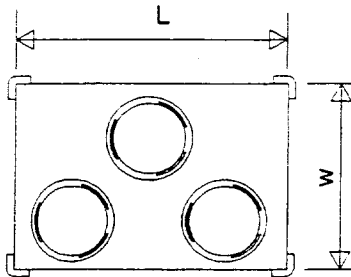

TOP VIEW

PLATE DISPENSER  
HEATED

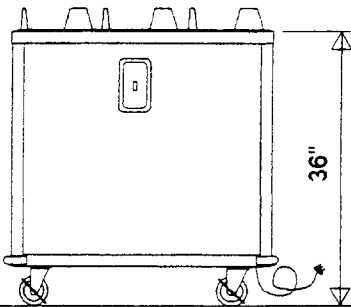

SIDE VIEW

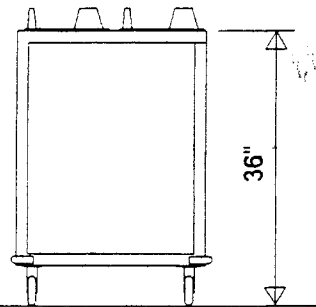

END VIEW

MODEL	DINNERWARE DIA.	L X W X H	AMPS 120-1PH	NEMA PLUG TYPE	SHIPPING WT
3PW-52	UP to 5"	35" x 22-1/4" x 36"	5.3	5-15P	180
2PW-60	5-7/8 to 5-3/4	35" x 22-1/4" x 36"	6.0	5-15P	180
3PW-66	5-7/8 to 6-1/2	35" x 22-1/4" x 36"	6.8	5-15P	180
3PW-74	6-5/8 to 7-1/4	35" x 22-1/4" x 36"	7.5	5-15P	180
3PW-83	7-3/8" to 8-1/8"	47" x 23-1/2" x 36"	8.3	5-15P	230
3PW-93	8-1/4" to 9-1/8"	47" x 23-1/2" x 36"	9.5	5-15P	230
3PW-103	9-1/4" to 10-1/8"	47" x 23-1/2" x 36"	10.5	5-15P	230
3PW-121	10-1/4" to 11-7/8"	49" x 26-1/8" x 36"	12.5	5-15P	265

TOP: 14 GAUGE STAINLESS STEEL WITH SQUARE TURN DOWNS ON ALL SIDES AND CORNERS FULLY WELDED AND GROUND AND POLISHED TO A #4 SATIN FINISH WITH ALL EDGES HAVING A #7 HI-LITE FINISH.

BODY AND FRAME: FRAME TO BE 14 GAUGE STAINLESS STEEL CONSTRUCTION. FULL PERIMETER TOP AND BOTTOM FRAME FULLY WELDED, GROUND AND POLISHED TO VERTICAL CORNER UPRIGHTS MAKING BODY FRAME ONE INTEGRAL UNIT. NON MARKING CORNER BUMPERS SECURED TO BOTTOM FRAME

BODY PANELS: SEAMLESS MOLDED FIBERGLASS (F.R.P.) WITH SMOOTH EXTERIOR SURFACE AND ROUNDED CORNERS. ALL FIBERGLASS TO BE FLAME RETARDANT PER SPECIFICATIONS ASTM-E-162 HAVING A FLAME SPREAD OF 25 OR LESS.

PLATE DISPENSERS: HEATED DISPENSERS TO BE FIELD ADJUSTABLE WITHOUT THE USE OF TOOL. FOR USE WITH PLASTIC OR CHINA DINNERWARE. CORRECT DISPENSING HEIGHT IS PRODUCED AUTOMATICALLY WHEN CORRECT SPRING RATE IS REACHED. BY CONNECTING SELF CONTAINED EXTENSION SPRINGS, THE SPRING RATE CAN BE INCREASED IN INCREMENTS OF 2.5 OZ/INCH OR 4 OZ/ INCH. A STORAGE BANK SHALL BE PROVIDED FOR EXTENSION SPRINGS WHEN NOT IN USE. TUBE TO BE ENCASED IN INDIVIDUAL STAINLESS STEEL JACKETS WITH A REINFORCED BOTTOM. EACH HEATED TUBE SHALL HAVE A SELF CONTAINED HEATING SYSTEM WITH AN INDIVIDUAL ON-OFF SWITCH, INDICATOR LIGHT AND THERMOSTAT. AN ELECTRICAL RECEPTACLE IS MOUNTED ON THE INTERIOR BOTTOM OF BODY WITH A 6 FOOT GROUNDED SUPPLY CORD. A CORD HANGING BRACKET IS TO BE PROVIDED ON BODY EXTERIOR. TUBES TO BE REMOVABLE FOR EASY CLEANING.

CASTERS: 4" DIAMETER BALL BEARING, SWIVEL TYPE, NON MARKING WITH BRAKES ON ALL WHEELS. CASTERS TO BE MOUNTED WITH INTERNAL AND EXTERNAL BRACING FOR MAXIMUM STRESS RELIEF.

APPROVALS: THIS UNIT IS LISTED BY UNDERWRITERS LABORATORIES FOR SAFETY AND CLASSIFIED BY UNDERWRITERS LABORATORIES BY SANITATION UNDER NSF STD 2 AND SHALL BEAR BOTH SEALS.

# COLORPOINT

3-95

BY LOW TEMP INDUSTRIES  
JONESBORO, GEORGIA

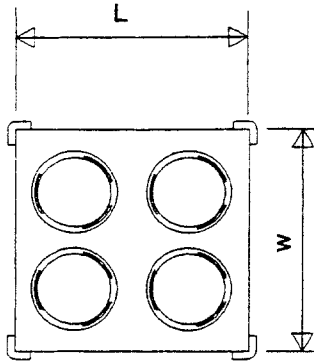

TOP VIEW

PLATE DISPENSER  
HEATED

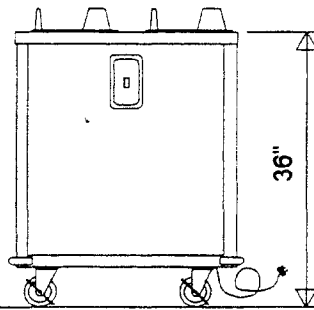

SIDE VIEW

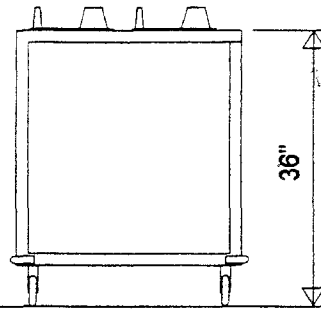

END VIEW

MODEL	DINNERWARE DIA.	L X W X H	AMPS 120-1PH	NEMA PLUG TYPE	SHIPPING WT
4PW-52	UP to 5"	29" x 29" x 36"	7.0	5-15P	200
4PW-60	5-1/8 to 5-3/4	29" x 29" x 36"	8.0	5-15P	200
4PW-66	5-7/8 to 6-1/2	29" x 29" x 36"	9.0	5-15P	200
4PW-74	6-5/8 to 7-1/4	29" x 29" x 36"	10.0	5-15P	200
4PW-83	7-3/8" to 8-1/8"	29" x 29" x 36"	11.0	5-15P	260
4PW-93	8-1/4" to 9-1/8"	29" x 29" x 36"	12.6	5-20P	260
4PW-103	9-1/4" to 10-1/8"	35" x 35" x 36"	14.0	5-20P	260
4PW-121	10-1/4" to 11-7/8"	35" x 35" x 36"	16.6	5-30P	320

TOP: 14 GAUGE STAINLESS STEEL WITH SQUARE TURN DOWNS ON ALL SIDES AND CORNERS FULLY WELDED AND GROUND AND POLISHED TO A #4 SATIN FINISH WITH ALL EDGES HAVING A #7 HI-LITE FINISH.

BODY AND FRAME: FRAME TO BE 14 GAUGE STAINLESS STEEL CONSTRUCTION. FULL PERIMETER TOP AND BOTTOM FRAME FULLY WELDED, GROUND AND POLISHED TO VERTICAL CORNER UPRIGHTS MAKING BODY FRAME ONE INTEGRAL UNIT. NON MARKING CORNER BUMPERS SECURED TO BOTTOM FRAME

BODY PANELS: SEAMLESS MOLDED FIBERGLASS (F.R.P.) WITH SMOOTH EXTERIOR SURFACE AND ROUNDED CORNERS. ALL FIBERGLASS TO BE FLAME RETARDANT PER SPECIFICATIONS ASTM-E-162 HAVING A FLAME SPREAD OF 25 OR LESS.

PLATE DISPENSERS: HEATED DISPENSERS TO BE FIELD ADJUSTABLE WITHOUT THE USE OF TOOL FOR USE WITH PLASTIC OR CHINA DINNERWARE. CORRECT DISPENSING HEIGHT IS PRODUCED AUTOMATICALLY WHEN CORRECT SPRING RATE IS REACHED. BY CONNECTING SELF CONTAINED EXTENSION SPRINGS, THE SPRING RATE CAN BE INCREASED IN INCREMENTS OF 2.5 OZ/INCH OR 4 OZ/INCH. A STORAGE BANK SHALL BE PROVIDED FOR EXTENSION SPRINGS WHEN NOT IN USE. TUBE TO BE ENCASED IN INDIVIDUAL STAINLESS STEEL JACKETS WITH A REINFORCED BOTTOM. EACH HEATED TUBE SHALL HAVE A SELF CONTAINED HEATING SYSTEM WITH AN INDIVIDUAL ON-OFF SWITCH, INDICATOR LIGHT AND THERMOSTAT. AN ELECTRICAL RECEPTACLE IS MOUNTED ON THE INTERIOR BOTTOM OF BODY WITH A 6 FOOT GROUNDED SUPPLY CORD. A CORD HANGING BRACKET IS TO BE PROVIDED ON BODY EXTERIOR. TUBES TO BE REMOVABLE FOR EASY CLEANING.

CASTERS: 4" DIAMETER BALL BEARING, SWIVEL TYPE, NON MARKING WITH BRAKES ON ALL WHEELS. CASTERS TO BE MOUNTED WITH INTERNAL AND EXTERNAL BRACING FOR MAXIMUM STRESS RELIEF.

APPROVALS: THIS UNIT IS LISTED BY UNDERWRITERS LABORATORIES FOR SAFETY AND CLASSIFIED BY UNDERWRITERS LABORATORIES BY SANITATION UNDER NSF STD 2 AND SHALL BEAR BOTH SEALS.

## TROUBLE SHOOTING SERVICE CHART

SERVICE TO BE PERFORMED BY QUALIFIED SERVICE TECHNICIAN ONLY.

<u>COMPLAINT</u>	<u>PROBLEM</u>	<u>SOLUTION</u>
LOAD PLATFORM WILL NOT DISPENSE EVENLY	1. SPRING LOAD INCORRECT	1. ADJUST SPRING TENSION BY ADDING OR TAKING SPRINGS
LIFT MECHANISM HANGS UP	1. DIRT IN MECHANISM 2. MECHANISM BENT OR DEFECTIVE	1. DISASSEMBLE AND CLEAN 2. REPLACE
HEATED MECHANISM WILL NOT HEAT	1. PLUG DISCONNECTED 2. DEFECTIVE HEATING ELEMENT 3. DEFECTIVE THERMOSTAT	1. CONNECT PLUG 2. REPLACE ELEMENT 3. REPLACE THERMOSTAT
HEATED MECHANISM WILL PROPERLY	1. DEFECTIVE THERMOSTAT 2. BAD POWER SUPPLY	1. REPLACE THERMOSTAT 2. CHECK INCOMING POWER

**REPLACEMENT PARTS LIST**

<b>ITEM NO.</b>	<b>DESCRIPTION</b>	<b>STOCK NO.</b>	<b>MFG. NO.</b>	<b>MANUFACTURER</b>
1	CASTERS 4" W/ BRAKES	130810	2-4056-43	JARVIS AND JARVIS
2	TRAY LOWERATOR SPRINGS	170070	GREEN	LOW TEMP

## **WARRANTY**

WE WARRANT TO THE ORIGINAL PURCHASER OF OUR PRODUCT, THAT ALL EQUIPMENT MANUFACTURED BY US IS FREE FROM DEFECTS IN MATERIAL OR WORKMANSHIP UNDER NORMAL USE AND SERVICE. OUR OBLIGATION UNDER THIS WARRANTY SHALL BE LIMITED TO REPAIRING OR REPLACING AT OUR OPTION, ANY PART OF SAID EQUIPMENT WHICH PROVES TO BE DEFECTIVE WITHIN A PERIOD OF ONE (1) YEAR FROM THE DATE OF THE ORIGINAL INSTALLATION AND WHICH ON OUR EXAMINATION SHALL DISCLOSE TO OUR SATISFACTION TO BE THUS DEFECTIVE. THIS WARRANTY IS IN LIEU OF ALL OTHER WARRANTIES EXPRESSED OR IMPLIED AND OF ALL OTHER OBLIGATIONS OR LIABILITIES ON THE PART OF THE CORPORATION. ALSO IT NEITHER ASSUMES NOR AUTHORIZES ANY OTHER PERSON TO ASSUME FOR IT ANY OTHER OBLIGATION OR LIABILITY IN CONNECTION WITH THE SALE OF SAID EQUIPMENT. THIS WARRANTY DOES NOT APPLY TO EQUIPMENT WHICH HAS BEEN SUBJECT TO ANY ACCIDENT, ALTERATION, ABUSE OR MISUSE. FURTHERMORE, THE WARRANTY DOES NOT COVER EQUIPMENT THAT HAS BEEN DAMAGED AS A RESULT OF FIRE, FLOOD, WIND STORM OR ANY OTHER ACT OF GOD, WAR WHETHER DECLARED OR UNDECLARED NOR SHALL WE BE RESPONSIBLE FOR THE LOSS OF FOOD OR OTHER PRODUCTS DUE TO LOSS OF POWER OR MECHANICAL FAILURE.

### **COLORPOINT FIBERGLASS FOOD SERVICE EQUIPMENT**

**A DIVISION OF LOW TEMP INDUSTRIES INC.**

**9192 TARA BOULEVARD**

**JONESBORO, GEORGIA 30236**

**(770) 478-8803**